



Shown: 16" Aluminum Flip Ramp - Optional

Direct Vertical Lift

DV Series™

Simplest to maintain and operate compared to other direct lifts, because of our revolutionary series hydraulic circuit design and automatic self-leveling system.

Key Features

- Automatic self-bleeding system equates to a simpler hydraulic system
- UHMW wear pads offer longer life
- Dock Bumpers are independent of the liftgate, allowing fast and simple repair, while protecting the rails
- Unique **standard** features include: power up and down control for smooth consistent cycling in all weather conditions, power open/close, platform that folds evenly in half, and dual power unit (standard only on DV 60)
- **Lifting capacity** - 4,500 - 6,000 lbs.
- **Applications** - straight trucks and trailers



Call 800-289-1335 in the U.S.
416-421-7987 in Canada

Visit our web site: www.ultronlift.com

Direct Vertical Lift Railgate Product Information

Clearance and Lift Dimensions

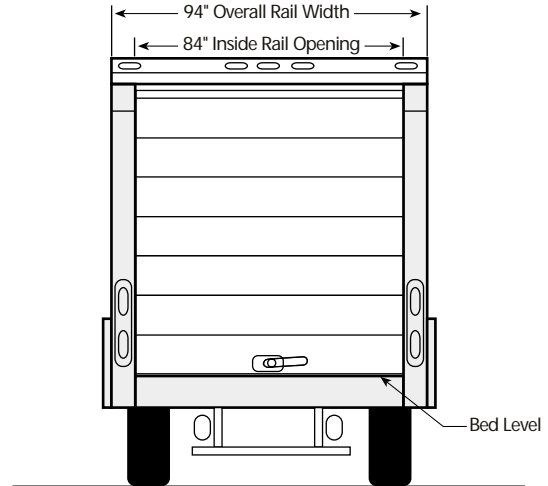
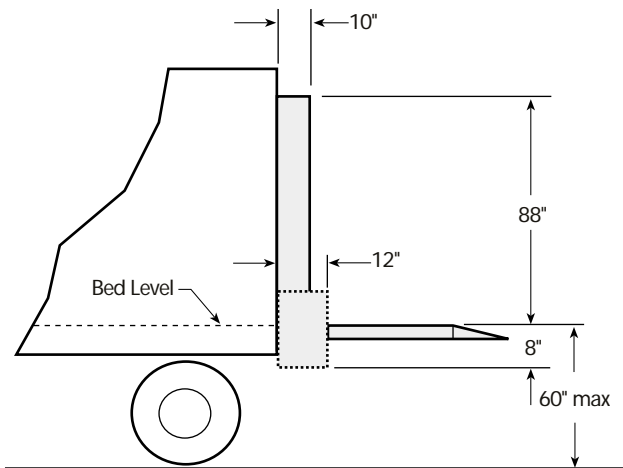

Specifications

Model*	Capacity lbs.	Min Dock Loading Bed Height**	Platform Area & Ramp	Overall Rail Width "	Power Up/ Power Down	Power Open/ Power Close
DV4560F	4500	40	80 X 60 + 12	94	✓	✓
DV4572F	4500	46	80 X 72 + 12	94	✓	✓
DV4584F	4500	52	80 X 84 + 12	94	✓	✓
DV6060F	6000	40	80 X 60 + 12	94	✓	✓
DV6072F	6000	46	80 X 72 + 12	94	✓	✓
DV6084F	6000	52	80 X 84 + 12	94	✓	✓

*F denotes folding platform. Straight platforms are available. The above represents standard size, non-standard sizes are available.

**Flip Ramp option accommodates 6" lower bed height for dock loading.

Standard Features

- Built in lights
- Circuit breaker and Master Disconnect Switch
- Maintenance free bushings
- Power unit: installed, tested, and sealed in pump box
- Hydraulic lock valve
- Capability to lift 60" from ground to bed
- Adjustable platform chain
- Steel cased 2 and 4 way rubber booted marine toggle switch
- 2 1/2" thick reinforced platform

Popular Options

- Automatic cart stops
- Aluminum platforms
- Auxiliary hand pumps
- Auxiliary power packs
- Non-standard platform width
- Non-standard platform depth
- Oversized ramp
- Additional toggle controls
- Trailer wiring kit
- Dock seal kit
- 102" wide
- 16" aluminum flip ramp



Authorized Distributor

E-mail: info@ultronlift.com • Web: www.ultronlift.com

Ultron Lift Corp.
 190 Lewis Street • PO Box 6126
 Buffalo, NY 14240-6126 USA
 Phone: 800-289-1335
 716-853-7994
 Fax: 716-854-5424

Ultron Lift Inc.
Les Hayons Ultron Inc.
 12 Industrial Street
 Toronto, ON M4G 1Y9 Canada
 Phone: 416-421-7987
 Fax: 416-421-7927