



Innovation that excites

2014
TITAN®



NISSAN TITAN®

What if your truck could put a smile on your face, confidence in your hands and goose bumps all over? That would be cool. Here are just a few ways Titan® gives you an unforgettable drive.

Muscle to flex. Titan™'s powerful 5.6-litre V8 lets you bring everything you need along, with up to 9500 lbs (4309 kg) of towing capacity.

Easy access. Nissan was the first to perfect the Wide Open rear door design you find on King Cab®. It makes getting in or loading up a snap.

A revolutionary bed. Titan™'s Utili-track® system changed truck beds forever, giving you a whole new way to lock down your cargo.

Looking for more? Visit Titan® on Facebook® or Twitter® to see what owners have to say. Find walkarounds, product demos and more on YouTube®.

And follow Nissan Canada on:



visit nissan.ca

19500 lbs. maximum towing on Titan™ SV King Cab® 4x2. See Nissan Towing Guide and Owner's Manual for proper use. Facebook® is a registered trademark of Facebook, Inc. Twitter® is a registered trademark of Twitter, Inc. YouTube® is a registered trademark of Google Inc.

All illustrations, photographs and specifications in this brochure are based on the latest product information. See actual vehicle for complete accuracy. Nissan Canada Inc. reserves the right to make changes at any time, without notice, in prices, colours, materials, equipment, specifications and models, and to discontinue models or equipment. For information on additional options and accessories, contact your Nissan Dealership. Registered trademarks are property of their respective owners.

At nissan.ca, you'll find virtual product demonstrations, a way to "build your own Nissan," a dealer locator, and more information about key Nissan support services. The Nissan names, logos, product names, feature names, and slogans are trademarks owned by or licenced to Nissan Motor Co. Ltd. and/or its North American subsidiaries. **Always wear your seat belt, and please don't drink and drive.** Printed in August 2013. Catalogue number: 99999-TTN13EN. © 2013 Nissan Canada Inc. All rights reserved.



Innovation that excites

WHAT IF_

EPIC CAME AS STANDARD EQUIPMENT?

Ready to expand your horizons? It's easy in the Nissan Titan.[®] Put your foot down on a powerful standard V8 engine that hits the road with up to 9500 lbs. of towing capacity.¹ Underneath, a fully boxed ladder frame handles just about any job on the list. While Titan[®]'s cabin and bed give you plenty of room. 2014 Nissan Titan.[®] No matter how epic your plans, it's ready.



Nissan Titan[®] PRO-4X[®] King Cab[®] shown in Glacier White.

¹9500 lbs. maximum towing on Titan[®] SV King Cab[®] 4x2. See Nissan Towing Guide and Owner's Manual for proper use.

317^{HP}

385^{LB-FT}
OF TORQUE

9500^{LBS. (4309 KG)}
MAXIMUM
TOWING¹



THE FEELING OF REELING IN THE BIG ONE.

It's always a good haul with a massive 5.6-litre V8. Punch the pedal and the exhaust system growls, while 385 lb-ft of torque kicks in to get the job done. Because this is one place where you don't want to hear about the one that got away.

What's power without torque? Especially the brute force of low-rev torque, i.e., 80% under 1000 rpm and 90% under 2500 rpm. Feel confident – Titan's got it.

Give yourself an efficiency boost. The Nissan Titan features a high-flow intake that maximizes every heaping gulp of air. Molybdenum-coated pistons and microfinished valves cut friction, ramp up smoothness and let revs rise faster.

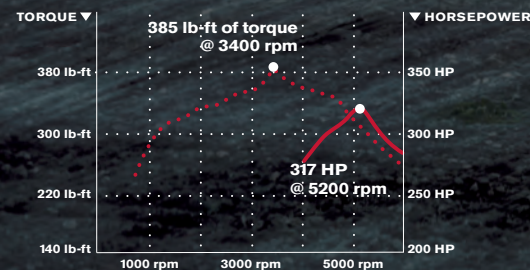

Nissan Titan® SV King Cab® 4x2 shown in Brilliant Silver. U.S. model shown.

Tow to the max. For that full 9500-lb. (4309 kg) pull, the SV King Cab® 4x2¹ boasts a lower final gear ratio, plus features like extendable tow mirrors and a heavy-duty battery.

THE FEELING OF MAKING MOLEHILLS OUT OF MOUNTAINS.

E-locker. When 4-Wheel Drive LO isn't enough for the crawl you've got planned, the available electronic locking rear differential is ready and extremely able. Flip the switch and this ultimate off-road feature delivers equal power to both rear wheels to boost traction and keep your truck moving forward.

4-Wheel Active Brake Limited Slip (ABLS). Keep your wheels from spinning. Titan® includes ABLS, a system that senses when a wheel begins to slip, then automatically brakes the slipping wheel (or wheels) and sends additional power to the wheel (or wheels) with the best traction. (2-wheel ABLS standard on 4x2 models.)

Vehicle Dynamic Control (VDC). When you're on-road – and paths are better defined – traction and control are key. VDC monitors the truck's dynamic response and helps compensate for oversteer or understeer to help keep you on your steered path².

Off-road-tuned Suspension. Take the bumps like a professional. Titan® PRO-4X®'s off-road-tuned suspension includes legendary Rancho® shocks for composure through the ugly stuff.

PRO-4X®

For those who like to live off-off-off the beaten path, the only choice is Titan® PRO-4X®. With extras like electronic locking rear differential, Rancho® off-road shocks, additional underbody skid plates – not to mention unique white-faced gauges – it's got the gear, the guts, the technology to handle it in places where success is measured in metres per minute.



Nissan Titan® PRO-4X® King Cab® 4x4 shown in Cayenne Red. U.S. model shown.

¹9500 lbs. maximum towing on Titan® SV King Cab® 4x2. See Nissan Towing Guide and Owner's Manual for proper use. ²VDC, which should remain on when driving except when freeing the vehicle from mud or snow, cannot prevent accidents due to abrupt steering, carelessness, or dangerous driving techniques. Always drive safely. Rancho® is a registered trademark of Tenneco Automotive Operating Company, Inc.

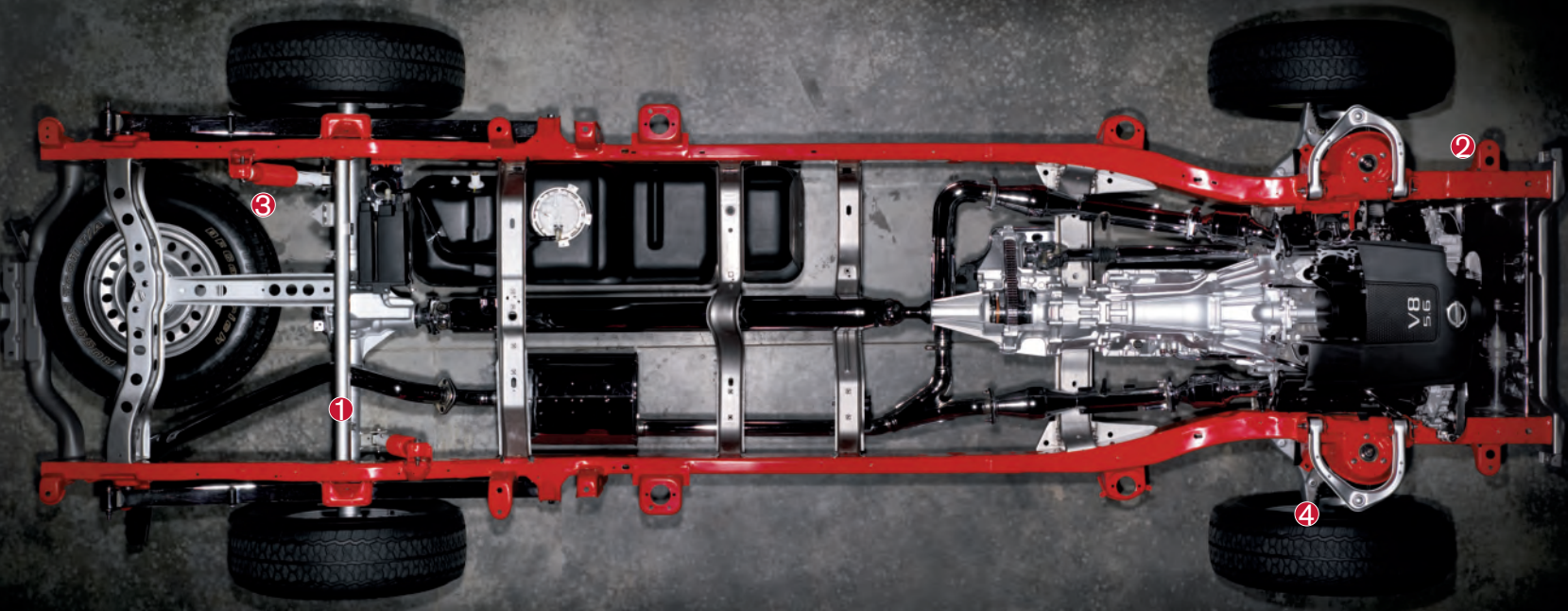

FOUR WALLS ARE STRONGER THAN THREE.

To build a better truck, sometimes you need to think inside the box. As in the fully boxed full-length ladder frame that's at the core of every Titan®. Some of our competitors use 3-sided open "C" rails instead. But you don't need to be a structural engineer to know the obvious – when building, four walls are stronger than three.

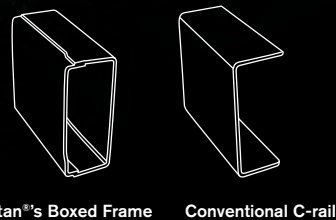

At its core, every Titan® stocks a fully boxed ladder frame, plus components built for no-nonsense performance.

- ① **Dana® axles** are built for durability. Wherever there's a drive wheel, there's a Dana axle.
- ② **Heavy-duty suspension** gives a smooth ride and firm, responsive handling. Double-wishbone up front, and multi-leaf springs in the rear.
- ③ **Rancho® shocks** set the standard for off-road toughness. Just what you'd expect from Titan® (exclusive to PRO-4X®).
- ④ **Beefy brakes** provide maximum contact area for rapid heat dissipation, long-lasting durability and confident towing.

NISSAN UTILI-TRACK®

INNOVATION THAT PUTS THE SUBMISSION HOLD ON CARGO.

Nissan's first-in-class Utili-track® cargo-carrying system holds a huge advantage over other trucks.¹ With five channels, including two on the bed floor, not just in the walls and header, you can have your way with cargo. Just position the four beefy aluminum-alloy cleats anywhere along the tracks, strap in your cargo, and put even the most awkward loads on lockdown.²

Nissan's revolutionary available Utili-track® system may have been copied by others, but its level of flexibility leads the way among full-size trucks. Combined with Titan's standard spray-on bedliner, and you've got one smart, long-lasting bed to haul what you need, work or play.²

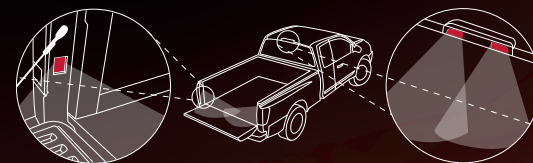

Bed Light and Tailgate Light. Shine a light on innovation. A pair of lights beam down into the bed; two other available task lights near the tailgate help you keep an eye on the job at hand.

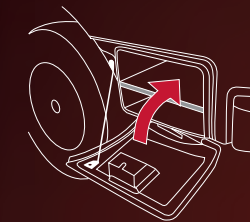
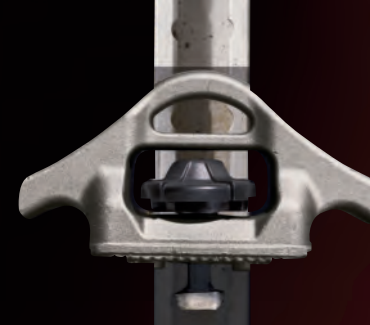

Bedside Storage. Another smart feature you'll only find on Titan®: an available driver-side tool box. It's climate-resistant, dual-level, and lockable.

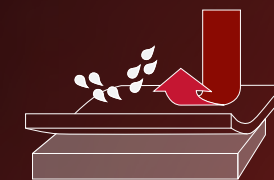

First-in-class Spray-on Bedliner! The spray-on bedliner helps resist the wear and tear of constant use, plus its UV-resistant surface helps guard against fading and the weather. And because it's sprayed on directly at the factory, it also fights warping and rust.

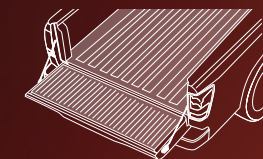

Tailgate Assist. Easy does it. Thanks to an available strut, the tailgate on a Titan® feels lighter and can be opened and closed with only one hand.



120-volt AC Power. Power where you need it. Titan's available 120-V outlet in the driver-side rear corner of the bed is perfect for powering or charging the tools you bring along.

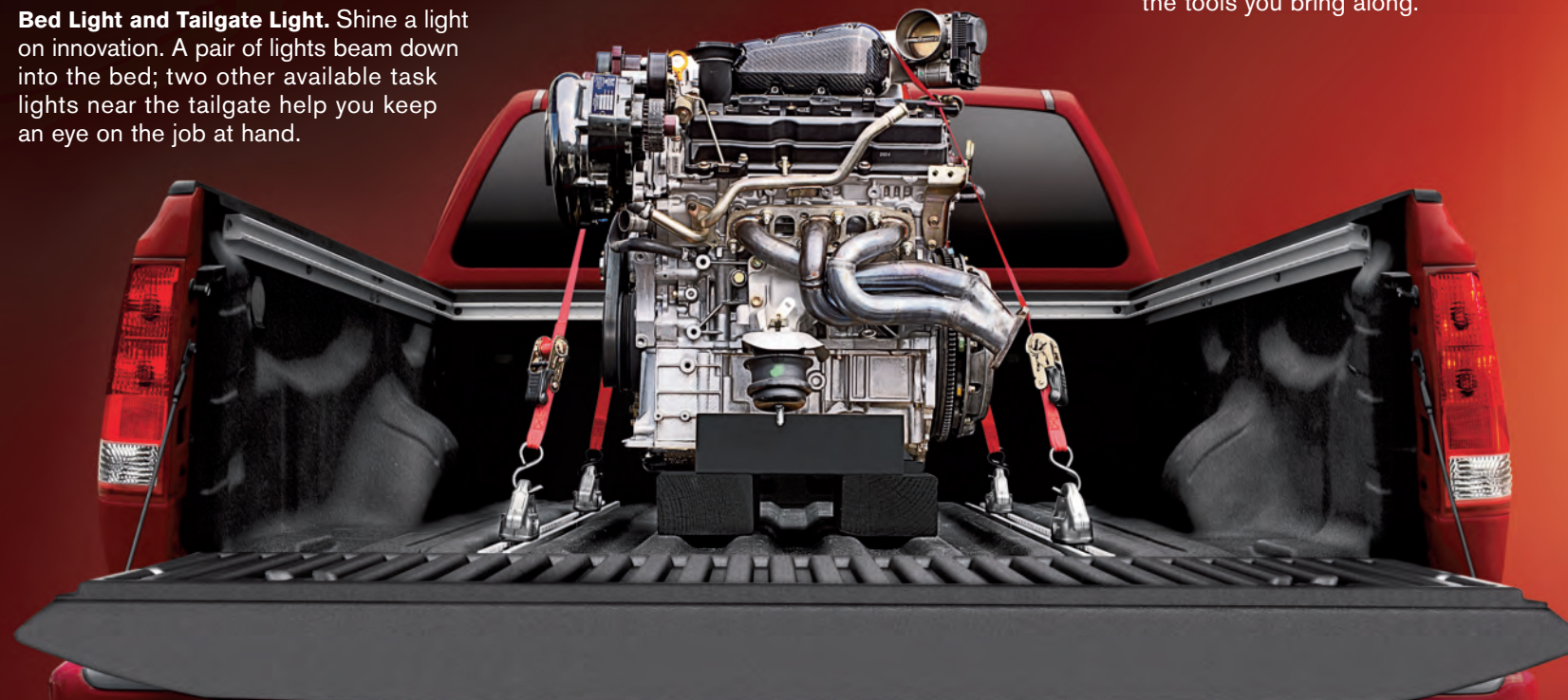

Some components have been chrome-plated or painted for display purposes only. ¹Association of International Automobile Manufacturers of Canada (AIAMC) Large Pickup Segmentation. ²Cargo and load capacity limited by weight and distribution. Always secure all cargo. ®Dana is a registered trademark of Dana Corporaion. ®Rancho is a registered trademark of Tenneco Automotive Operating Company, Inc.

Nissan Titan® PRO-4X® Crew Cab 4x4 shown in Charcoal Leather with PRO-4X® Option Package.

Titan® takes your comfort personally – even if you have to share sometimes. Premium details include an available memory function that locks in the perfect settings for your driver's seat, outside mirrors and power adjustable pedals. Dual Zone Automatic Temperature Control (ATC) that lets you and your front passenger set your own climates. And when the temperature dips outside, available heated front seats warm things up.



Details that work beautifully. When you need to get down to business, fold down the front passenger seat and you've got a convenient writing desk. On models with captain's chairs, the centre console holds a surprise: a handy 120-volt charging point, and a lockable storage area big enough for a laptop or hanging file folders.



RearView Monitor. Titan®'s available RearView Monitor not only helps you see what's behind you, but comes in real handy when you're hitching a trailer.⁶



Available **Bluetooth® Hands-Free Phone System** lets you make and take calls with your hands on the wheel.³



120-volt AC power. An available 120-volt outlet means you can charge your laptop while it's safely concealed in the console.



Available **10-speaker Rockford Fosgate-powered audio system**, including SiriusXM Satellite Radio, makes your tunes sound their best.⁴



Nissan Titan® SL Crew Cab 4x4 shown in Charcoal Leather. U.S. instrumentation shown.

NISSANCONNECT^{SM1} WITH NAVIGATION²

Bluetooth® audio streaming. Want to let your passengers play DJ? Just connect a Bluetooth®-enabled audio device to stream music wirelessly, from any seat in the cabin.³

SiriusXM Satellite Radio. Looking to expand your taste? With available SiriusXM Satellite Radio, you can explore emerging artists or even rediscover an old favourite. More than 100 stations means there's always plenty to choose from, like commercial-free music, sports, talk radio and more – giving you hours of endless entertainment.⁴

iPod®/USB input. Would you like to be able to listen to your own playlists or podcasts? With the available iPod®/USB input, you can. Plug in your iPod® or other portable MP3 player through the USB port and control it through Titan®'s audio controls.⁵

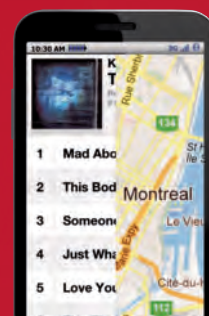

Nissan Navigation System. Titan®'s available 147-mm (5.8") touch-screen display offers NavTraffic for real-time advisories to keep you on the move. You can even get the latest fuel prices, weather forecasts, and flight status information, right in the display.^{2,4}

Hands-free text messaging assistant. Now you can receive and respond to text messages without ever touching your phone. Have your messages read to you and select from pre-set responses, right in the display.⁷

Points of Interest powered by Google® Find that new restaurant in a snap. Based on the latest information, Google® Points of Interest lets you search for a location, even without knowing the name or category. Once you find it, select it and you're on your way.¹

Google® Send-to-Car. Send an address to your Nissan Navigation System from any computer. When you start the car and connect to the network, the directions will be delivered and loaded into your navigation system. Now, that's cool.^{1,2}

¹POIs powered by Google®, Google® Send-to-Car, Real-Time Weather, Real-Time Fuel Prices, and Real-Time Flight Information may require subscription and owner consent to activate. Service[s] provided by independent companies not within Nissan's control. Should service providers terminate/restrict service, service may be suspended or terminated without notice or liability to Nissan and/or its agents. Nissan not responsible for any equipment replacement or upgrades, or associated costs, that may be required for continued operation due to service changes. Certain remote functions require compatible phone, not included with vehicle. Cellular network provided by independent cellular companies not within Nissan's control. Cellular network not available in all areas. Standard text rates, voice minutes, roaming charges and/or data usage may apply. ²Factory-installed option. Never program while driving. GPS mapping may not be detailed in all areas or reflect current road regulations. ³Availability of specific features is dependent upon the phone's Bluetooth® support. Please refer to your phone Owner's Manual for details. The Bluetooth word mark and logos are owned by Bluetooth SIG, Inc., and any use of such marks by Nissan is under licence. *XM and SiriusXM Satellite Radio is available in the 10 Canadian provinces and the 48 contiguous United States. Basic monthly subscription required and sold separately after trial period. NavTraffic® is available in select North American markets. In Canada, at time of printing, incident and flow data is available for 7 metropolitan areas of Canada (Vancouver, Calgary, Edmonton, Toronto, Ottawa, Montreal and Quebec City). Limited flow data is available for Toronto. Subscription sold separately after trial period. All subscriptions subject to customer agreement at siriusxm.ca/terms. All fees and programming subject to change. © 2013 Sirius XM Canada Inc. The Sirius, XM,

and SiriusXM names and all related marks and logos are trademarks of Sirius XM Radio Inc. All other trademarks are the property of their respective owners. ⁵Driving is serious business and requires your full attention. Do not operate any devices connected to the USB or auxiliary audio input jack while driving. ⁶Parking aid/convenience feature. Cannot completely eliminate blind spots or warn of moving objects. May not detect every object. Always check surroundings before moving vehicle. Not a substitute for proper backing procedures. Always turn to check what is behind you before backing up. ⁷Use the text messaging feature after stopping your vehicle in a safe location. If you have to use the feature while driving, exercise extreme caution at all times so full attention may be given to vehicle operation. Google® is a registered trademark of Google Inc. iPod® is a registered trademark of Apple, Inc. All rights reserved. iPod not included.

GO WIDE – KING CAB®.

The Wide Open rear doors on Titan® King Cab® make entering or loading the cabin a snap. Other trucks out there may have imitated the design, but Nissan was the first to perfect the Wide Open door. And with no B-pillar to get in the way, plus a fold-up rear bench seat, your cargo flexibility is as wide open as your doors.

- Two available seating configurations:
6-passenger with front bench seat or 5-passenger with front captain's chairs
- Standard rear fold-up bench seat and a flat loading floor for more usable area



Nissan Titan® SV King Cab® 4x2 shown in Gun Metallic. U.S. model shown.

GO LONG – CREW CAB.

As in the longest Crew Cab bed in its class.¹ Plenty of room for whatever you need to bring along – work or play. While inside the massive cabin, you'll find more head room than Toyota Tundra, more front leg room than Chevy Silverado or Ford F-150 and bigger overall passenger volume vs. Ram 1500 Crew Cab.²

- 5-passenger seating with front captain's chairs
- Huge interior with 3557 L (126 cu. ft.) of passenger room
- Two available bed lengths:

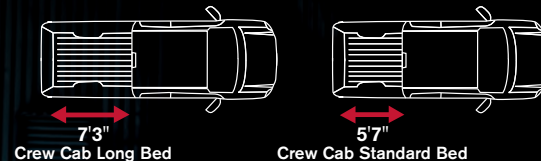

Nissan Titan® SV Crew Cab 4x4 shown in Brilliant Silver. U.S. model shown.

CHOOSE YOUR TRIM LEVEL

S KING CAB® CREW CAB

Features 317 HP 5.6-litre DOHC V8, 5-speed automatic transmission, 4-wheel disc brakes with ABS, 18" aluminum-alloy wheels, Wide Open rear doors, body-colour front bumper and black grille, cruise control, air conditioning, tilt steering wheel, 6-passenger capacity, front bench seat with fold-down centre console armrest, 60/40 split flip-up rear bench seat, spray-on bedliner, rear tailgate spoiler, AM/FM/CD audio system, six standard airbags, and Vehicle Dynamic Control (VDC). **Crew Cab adds:** 4x4 drivetrain, 4-wheel Active Brake Limited Slip (ABLS), power front and rear windows, power back window, rear privacy glass, rear reading lights, and carpeted flooring.



SV KING CAB® CREW CAB CREW CAB LONG BED

Includes S equipment plus:

Upgraded tires, chrome grille and bumpers, heavy-duty battery, hitch receiver, tow hooks, Utili-track® Channel System, lockable bedside storage, tailgate illumination, Rear Sonar System³, two 120-volt AC power outlets, power heated outside tow mirrors, centre console with gated shifter, 8-way power driver's seat, fold-down front-passenger's seat, leather-wrapped steering wheel, AM/FM/CD audio system with colour display, RearView Monitor, USB connection port, Bluetooth® Hands-Free Phone System, SiriusXM Satellite Radio,⁴ power door locks and windows, and remote keyless entry.

Crew Cab adds: 4x4 drivetrain and power rear window with defroster.

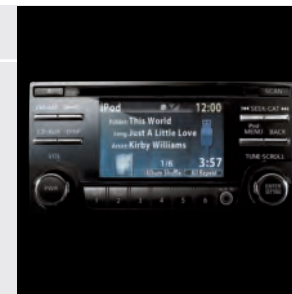

PRO-4X® KING CAB® CREW CAB

Includes SV 4x4 equipment plus:

Locking rear differential, 18" dark-finished aluminum-alloy off-road wheels with P275/70R18 tires, Rancho® off-road performance shocks, skid plates (transfer case and lower radiator), body-colour bumpers, satin chrome-finished grille, automatic on/off headlights, fog lights, Rockford Fosgate audio system, and unique interior trim and gauges.

AVAILABLE PACKAGE:

- PRO-4X® Option Package (Crew Cab only)

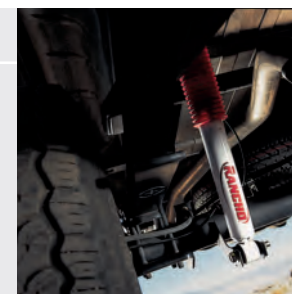

SL CREW CAB

Includes SV equipment plus:

20" Chrome-clad alloy wheels, automatic on/off headlights, fog lights, chrome tubular step rails, power sliding glass moonroof, NissanConnectSM with Navigation, Rockford Fosgate audio system, Dual Zone Automatic Temperature Control (ATC), 4-way power front-passenger's seat, leather-appointed seats, heated front seats, Memory System (driver's seat, outside mirrors and pedals), and wood-tone trim.



¹Association of International Automobile Manufacturers of Canada (AIAMC) Half-ton Large Pickup Segmentation. ²2014 Titan Crew Cab vs. 2014 Toyota Tundra, Ford F-150, Ram 1500 Crew Cab and 2013 Chevy Silverado. ³The optional Rear Sonar System is a convenience, but is not a substitute for proper backing procedures. Always turn and check that it is safe to do so before backing up. The Rear Sonar System may not detect every object behind you. ⁴XM and SiriusXM Satellite Radio is available in the 10 Canadian provinces and the 48 contiguous United States. Basic monthly subscription required and sold separately after trial period. Subscription subject to customer agreement at siriusxm.ca/terms. All fees and programming subject to change. © 2013 Sirius XM Canada Inc. The Sirius, XM, and SiriusXM names and all related marks and logos are trademarks of Sirius XM Radio Inc. All other trademarks are the property of their respective owners. The Bluetooth word mark and logos are owned by Bluetooth SIG, Inc., and any use of such marks by Nissan is under licence. ⁵Rancho is a registered trademark of Tenneco Automotive Operating Company, Inc.

PAINT AND FABRIC

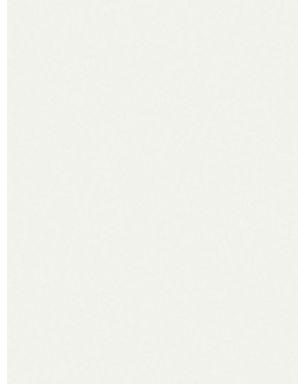

Glacier White QAK



Pearl White¹ QAB



Brilliant Silver¹ K23



Cayenne Red¹ NAH



Graphite Blue¹ RAQ



Gun Metallic¹ KAD

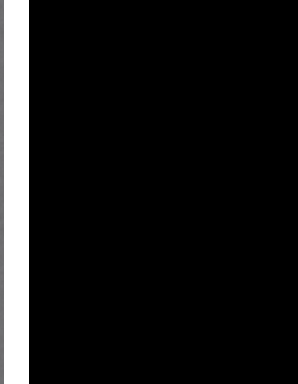

Galaxy Black¹ G10



Espresso Black¹ CAE

- Standard
- Part of PRO-4X[®] Option Package
- ¹Extra cost option

Nissan has taken care to ensure that the colour swatches presented here are the closest possible representations of actual vehicle colours. Swatches may vary slightly due to the printing process and whether viewed in daylight, fluorescent or incandescent light. Please see the actual colours at your local Nissan dealer.

	S	SV	PRO-4X [®]	SL
ALMOND CLOTH				
ALMOND LEATHER				
CHARCOAL CLOTH	■	■	■	
CHARCOAL LEATHER			□	

	S	SV	PRO-4X [®]	SL
ALMOND CLOTH				
ALMOND LEATHER				
CHARCOAL CLOTH				
CHARCOAL LEATHER				■

	S	SV	PRO-4X [®]	SL
ALMOND CLOTH				
ALMOND LEATHER				
CHARCOAL CLOTH	■	■		
CHARCOAL LEATHER				■

	S	SV	PRO-4X [®]	SL
ALMOND CLOTH				
ALMOND LEATHER				
CHARCOAL CLOTH	■	■		
CHARCOAL LEATHER			□	■

	S	SV	PRO-4X [®]	SL
ALMOND CLOTH				
ALMOND LEATHER				
CHARCOAL CLOTH		■	■	
CHARCOAL LEATHER			□	■

	S	SV	PRO-4X [®]	SL
ALMOND CLOTH				
ALMOND LEATHER				
CHARCOAL CLOTH	■	■	■	
CHARCOAL LEATHER			□	■

	S	SV	PRO-4X [®]	SL
ALMOND CLOTH				
ALMOND LEATHER				
CHARCOAL CLOTH	■	■	■	
CHARCOAL LEATHER			□	■

	S	SV	PRO-4X [®]	SL
ALMOND CLOTH				
ALMOND LEATHER				
CHARCOAL CLOTH		■		
CHARCOAL LEATHER			□	■



S CHARCOAL CLOTH



SV ALMOND CLOTH



SV CHARCOAL CLOTH



PRO-4X[®] CHARCOAL CLOTH



PRO-4X[®] CHARCOAL LEATHER



SL ALMOND LEATHER



SL CHARCOAL LEATHER

GENUINE NISSAN ACCESSORIES

Every Genuine Nissan Accessory is: custom-fit, custom-designed and durability-tested; backed by Nissan's 3 year/60,000 km Accessories limited warranty; and can be financed when installed by dealer at time of purchase.²

A. Sliding Bed Extender

Perfect for the long haul.

B. Sliding Tool Box

Slide it forward when you're on the move. Slide it back for easy access on the job.

C. Side-window Deflectors

Enjoy fresh air with less wind noise.

D. Hood Deflector

Bugs and road grime won't bug you.

Additional Accessories:

- All-season Floor Mats
- Torza Top Tonneau Cover
- Moonroof Wind Deflector
- Step Rails
- Retractable Rear Bumper Step
- Chrome Taillight Guard
- Telescoping Mirrors
- Bed Rails
- Chrome Wheels
- Bed Tent
- And More



See your Nissan dealer for details, or go to accessories.nissan.ca

BUYING AND OWNING

Finance Options Through Nissan Canada Finance, we offer many attractive purchase and lease programs, all with competitive rates and terms. With our flexible finance options, driving home a new Nissan has never been easier. Consult your local Nissan Dealership for complete details.

No-Nonsense Warranty Every 2014 Nissan is covered by a 3 year/60,000 km³ Comprehensive New Vehicle Warranty, a 5 year/100,000 km³ Powertrain Warranty, an 8 year/130,000 km³ Emission Control Warranty on selected components, and a 5 year/unlimited km Corrosion Perforation Warranty. As a Nissan owner, you'll also receive a 3 year Roadside Assistance program available to you 24 hours a day. Terms, conditions and exclusions apply. See Warranty Information Booklet for complete details.

Added Security Plan (ASP) For ultimate peace of mind, consider the Nissan Added Security Plan. It's our commitment to be there for you, and to help you leave your worries behind. Different plans, available for both purchased and leased vehicles, let you tailor the coverage to your driving habits.

²See your Nissan Dealership and read the actual limited warranty. ³Whichever occurs first.

Security+Plus™ Prepaid Maintenance Plan The smart choice when it comes to maintaining your new Nissan. Honoured at all participating Nissan Dealers in Canada and the U.S., your vehicle is cared for by factory-trained technicians using Genuine Nissan Parts. And best of all, there's no worrying about price increases on parts or service in the future. A variety of plans are available. Ask your Dealer for details.

Nissan's environmental action plan focuses on several key areas. Increasing production of Zero Emission vehicles, including the 100% electric LEAF™. Improving fuel efficiency through our PUREDRIVE™ measures. And reducing the environmental impact of manufacturing, as seen at our new, energy-efficient, low-emissions paint plant in Tennessee.



NISSAN
GREEN PROGRAM

FEATURES AND SPECIFICATIONS

Engine	← KING CAB® →			← CREW CAB →			
	S 4x2	SV 4x2 4x4	PRO-4X® 4x4	S 4x4	SV 4x4	PRO-4X® 4x4	SL 4x4
VK56DE – 5.6-litre DOHC 32-valve V8 engine							
Horsepower – 317 HP @ 5200 rpm							
Torque – 385 lb-ft @ 3400 rpm							
Heavy-duty battery (710 CCA)							
Engine block heater							
Drivetrain							
5-speed automatic transmission with Tow/Haul Mode							
Lower final gear ratio (3.357:1)							
Shift-on-the-fly 4-Wheel Drive 2-speed transfer case							
4WD (4H – 1.000; 4LO – 2.596)							
Switch-on-demand electronic locking rear differential							
Brakes							
Front and rear vented disc brakes							
4-wheel Anti-lock Braking System (ABS)							
Electronic Brake force Distribution (EBD) and Brake Assist							
Suspension/Steering							
Independent double-wishbone front suspension with stabilizer bar (Dana® axle on 4x4 models)							
Multi-leaf rear suspension with solid Dana® axle							
Rancho® high-performance shocks							
Engine-speed-sensitive power-assisted rack-and-pinion steering							
Wheels/Tires							
18" x 8.0" 5-spoke aluminum-alloy wheels							
18" x 8.0" 6-spoke aluminum-alloy wheels							
18" x 8.0" 6-spoke dark finished aluminum-alloy wheels							
20" x 8.0" 5-spoke chrome-clad alloy wheels							
P265/70R18 tires							
P265/70R18 tires with raised outlined white lettering							
P275/70R18 tires with raised outlined white lettering							
P275/60R20 tires							
Exterior Features							
Standard Bed							
Long Bed							
Fuel tank skid plate, oil pan skid plate (4x4)							
Transfer case skid plate and lower radiator skid plate							
Automatic on/off headlights							
Chrome tubular step rails							
Fog lights							
Front tow hooks							
Tow hitch receiver							
Body-colour front bumper and painted silver rear bumper							
with black grill							
Chrome grille and bumpers							
Body-colour front and rear bumpers with satin chrome grille							
Black manual outside mirrors and door handles							
Black power heated outside tow mirrors and door handles							
Chrome power heated outside tow mirrors and door handles							
Body-colour side mouldings							
Rear Sonar System							
Rear privacy glass							
Bed rope hooks, stake holder and separator/shelf provision							
Utili-track® Channel System with four tie-down cleats							
Factory-applied spray-on bedliner							
Lockable driver-side bedside storage							
Tailgate illumination and bed-mounted 120-volt AC power outlet							

Exterior Features (continued)	← KING CAB® →			← CREW CAB →			
	S 4x2	SV 4x2 4x4	PRO-4X® 4x4	S 4x4	SV 4x4	PRO-4X® 4x4	SL 4x4
Locking tailgate with rear spoiler and cargo bed light							
Sliding rear window (power rear window on CC)							
Power sliding glass moonroof (one-touch open/close)							
Comfort/Convenience							
NissanConnect™ with Navigation, including 147 mm (5.8") colour touch-screen monitor							
Nissan Voice Recognition for audio and navigation							
NavTraffic ²							
POIs powered by Google® and Google® Send-to-Car							
Hands-free text messaging assistant							
RearView Monitor							
Bluetooth® Hands-Free Phone System							
Air conditioning							
In-cabin microfilter							
Dual Zone Automatic Temperature Control (ATC)							
Power windows and door locks							
Remote keyless entry with remote windows down							
HomeLink® universal garage-door opener							
Cruise control with steering wheel-mounted controls							
Variable intermittent wipers							
Tilt steering column							
Front door courtesy lights							
Auto-dimming rearview mirror							
Digital compass and outside temperature display							
Centre console-mounted 120-volt AC power outlet							
Digital clock, retained accessory power, and battery saver							
Transmission temperature gauge							
Sun visors with illuminated vanity mirrors and extension							
Power adjustable pedals							

Seating/Appointments	S 4x2	SV 4x2 4x4	PRO-4X® 4x4	S 4x4	SV 4x4	PRO-4X® 4x4	SL 4x4
40/20/40 split front bench seat with fold-down centre console							
Front captain's chairs with driver-side manual lumbar							
8-way power driver's seat							
4-way power front-passenger's seat							
Heated front seats							
Fold-down front-passenger's seat							
60/40 Split flip-up/fold-down rear bench seat							
Memory System – driver's seat, outside mirrors, and pedals							
Cloth seat trim							
Two-tone cloth seat trim with white stitching							
Leather-appointed seats							
Column shifter with manual shift mode							
Leather-wrapped transmission shifter and steering wheel							
Driver seatback pocket (captain's chairs only)							
Up to eight cup holders on CC (six on KC)							
Overhead centre console							
Overhead rear centre console							
Wood-tone trim							
White-faced gauges							
Rear reading lights							
Easy Clean vinyl flooring							
Carpeted flooring							

Audio/Entertainment	S 4x2	SV 4x2 4x4	PRO-4X® 4x4	S 4x4	SV 4x4	PRO-4X® 4x4	SL 4x4
AM/FM/CD audio system							
AM/FM/CD audio system with colour display							
Rockford Fosgate-powered AM/FM/CD audio system							
with colour display							

Audio/Entertainment (continued)	← KING CAB® →			← CREW CAB →			
	S 4x2	SV 4x2 4x4	PRO-4X® 4x4	S 4x4	SV 4x4	PRO-4X® 4x4	SL 4x4
MP3/WMA playback capability							
Radio Data System (RDS)							
SiriusXM Satellite Radio ²							
Streaming audio via Bluetooth® wireless technology							
USB connection port for iPod® interface and other compatible devices							
Steering wheel-mounted audio controls							
Eight speakers on CC; six speakers on KC							
Ten speakers on CC; eight speakers on KC							
Safety/Security							
Nissan Advanced Airbag System with dual-stage supplemental front airbags with seat belt sensors and occupant-classification sensor							
Driver and front-passenger side-impact supplemental airbags							
Roof-mounted curtain supplemental airbags for side-impact and rollover protection for front and rear outboard occupants							
Vehicle Dynamic Control (VDC) with Traction Control System (TCS)							
Active Brake Limited Slip (ABLS)							
Front-seat Active Head Restraints							
3-point ALR/ELR passenger seat belt system (ELR for driver)							
Front seat belts with pre-tensioners and load limiters							
LATCH System (Lower Anchors and Tethers for CHildren)							
Zone Body construction with front and rear crumple zones							
Hood-buckling creases and energy-absorbing steering column							
Pipe-style steel side-door guard beams							
Tire Pressure Monitoring System (TPMS)							
Anti-theft system and Immobilizer Key System							

The Nissan Safety Shield®. Over 50 standard safety features, including six standard airbags and front-seat Active Head Restraints. All with one goal in mind: to help you and your loved ones be safe.

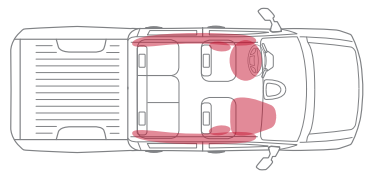

Six standard airbags. Start with dual-stage supplemental front airbags, including an occupant-classification sensor. If the front-passenger seat is empty, for example, the sensor deactivates that airbag. Built into the front seats are seat-mounted side-impact supplemental airbags. They even move with you when you adjust your preferred seating position. Up above are roof-mounted curtain supplemental airbags for both rows. They work to help provide enhanced head protection for outboard occupants.³

Ready with a rollover sensor. In the unlikely event of a rollover, Titan® has already thought ahead. Every Titan® has a sensor that detects an impending rollover, then deploys the curtain airbags to help protect you.

¹4x4 only. ²XM and SiriusXM Satellite Radio is available in the 10 Canadian provinces and the 48 contiguous United States. Basic monthly subscription required and sold separately after trial period. NavTraffic® is available in select North American markets. In Canada, at time of printing, incident and flow data is available for 7 metropolitan areas of Canada (Vancouver, Calgary, Edmonton, Toronto, Ottawa, Montreal and Quebec City). Limited flow data is available for Toronto. Subscription sold separately after trial period. All subscriptions subject to customer agreement at siriusxm.ca/terms. All fees and programming subject to change. © 2013 Sirius XM Canada Inc. The Sirius, XM, and SiriusXM names and all related marks and logos are trademarks of Sirius XM Radio Inc. All other trademarks are the property of their respective owners. ³Airbags are only a supplemental restraint system; always wear your seat belt. Even with the occupant-classification sensor, rear-facing child restraints should not be placed in the front-passenger's seat. Also, in addition to any other requirement of applicable law, all children 12 and under should ride in the rear seat properly secured in child restraints, booster seats, or seat belts according to their size. Airbags will only inflate in certain accidents; see your Owner's Manual for more details. Inflated airbags shown for illustration purposes only. Actual coverage area may differ. Airbags deflate after deployment. The Bluetooth® word mark and logos are owned by Bluetooth SIG, Inc., and any use of such marks by Nissan is under licence. Dana® is a registered trademark of Dana Corporation. Google® is a registered trademark of Google Inc. HomeLink® is a registered trademark of Johnson Controls Technology Company. iPod® is a registered trademark of Apple, Inc. All rights reserved. iPod not included. ®Rancho is a registered trademark of Tenneco Automotive Operating Company, Inc.

PACKAGE

PRO-4X® Option Package (Crew Cab)
Power sliding glass moonroof
▪ NissanConnect™ with Navigation, including 147 mm (5.8") colour touch-screen monitor
▪ Nissan Voice Recognition for audio and navigation
▪ POIs powered by Google® and Google® Send-to-Car
▪ NavTraffic ²
▪ Hands-free text messaging assistant
▪ Streaming audio via Bluetooth® wireless technology
▪ PRO-4X® embroidered leather-appointed seats
▪ Heated front seats
▪ Memory System – driver's seat, outside mirrors, and pedals
▪ 4-way power passenger's seat
▪ In-cabin microfilter

DIMENSIONS/CAPACITIES/WEIGHTS/FUEL

Dimensions – mm (inches)			
Exterior	King Cab® Standard Bed	Crew Cab Standard Bed/Long Bed	
Wheelbase	3550 (139.8)	3550 (139.8)/4050 (159.5)	
Overall length	5704 (224.6)	5704 (224.6)/6204 (244.2)	
Overall width	2019 (79.5)	2019 (79.5)	
Overall height	1890–1945 (74.6–76.6)	1937–1953 (76.3–76.9)	
Bed length	2010 (79.1)	1710 (67.3)/2210 (87.0)	
Bed width	1620 (63.8)	1620 (63.8)	
Bed opening width	1530 (60.2)	1530 (60.2)	
Bed width between wheelhouse	1270 (50.0)	1270 (50.0)	
Bed depth	506 (19.9)	506 (19.9)	
Interior (front/rear)			
Head room	1040/988 (41.0/38.9)	1040/1026 (41.0/40.4)	
With moonroof	NA	1008/1026 (39.7/40.4)	
Leg room	1063/837 (41.8/33.0)	1063/1026 (41.8/40.4)	
Hip room	1558/1531 (61.3/60.3)	1558/1536 (61.3/60.5)	
Shoulder room	1654/1648 (65.1/64.9)	1654/1640 (65.1/64.6)	
Capacities			
	King Cab®	Crew Cab	
Seating capacity			
With front bench seat	6	6	
With front captain's chairs	5	5	
Interior passenger volume – L (cu. ft.)	3194 (112.8)	3557 (125.6)	
Fuel tank – L (gal)	106 (23.3)	106 (23.3)	
	King Cab® 4x2 Standard Bed	King Cab® 4x4 Standard Bed	Crew Cab 4x4 Standard Bed/Long Bed
Payload – kg (lbs)			
S	961 (2118)	NA	848 (1869)/NA
SV	892 (1966)	829 (1827)	779 (1717)/671 (1479)
PRO-4X®	NA	791 (1743)	745 (1644)/NA
SL	NA	NA	704 (1552)/NA
Maximum towing capacity – kg (lbs)			
S	2948 (6500)	NA	2948 (6500)/NA
SV	4309 (9500)	4264 (9400)	4218 (9300)/4082 (9000)
PRO-4X®	NA	4218 (9300)	4218 (9300)/NA
SL	NA	NA	4128 (9100)/NA
Curb Weights – kg (lbs)			
	King Cab® 4x2 Standard Bed	King Cab® 4x4 Standard Bed	Crew Cab 4x4 Standard Bed/Long Bed
S	2262 (4987)	NA	2453 (5409)/NA
SV	2262 (4987)	2373 (5231)	2516 (5546)/2620 (5778)
PRO-4X®	NA	2373 (5231)	2550 (5621)/NA
SL	NA	NA	2576 (5679)/NA
2014 Fuel Consumption Estimates – L/100 km (MPG)			
4x2 city	16.1 (18)	4x4 city	17.8 (16)
4x2 hwy	10.9 (26)	4x4 hwy	12.2 (23)
NA – Not applicable. Actual mileage may vary with driving conditions – use for comparison only.			

■ Standard □ Optional ☐ Part of PRO-4X® Option Package