



BLUE BIRD

February 22, 2013

SERVICE MEMORANDUM NO. SM1303

MEMO TO: All Blue Bird Dealers

SUBJECT: Service Information on Dana Rear Axle

MODEL YEAR(S): 2012, 2013 and 2014

MODEL(S) AFFECTED: All American Front Engine, All American Rear Engine, and Blue Bird Vision

Some Blue Bird All American and Vision buses have Dana Spicer rear axles. To determine whether your bus has a Dana Spicer or Meritor axle, see the axle identification plate on axle housing. Axles shown below are for reference and the identification location may vary. Service information for Meritor axles are in the Blue Bird Service Manuals. Attached is an advance copy of the Spicer Drive Axle Service Manual to assist in servicing your vehicle. Plans are to include this information in future Blue Bird Service Manuals.

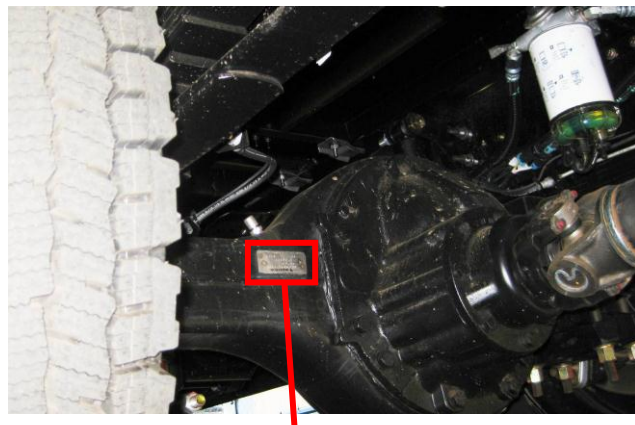
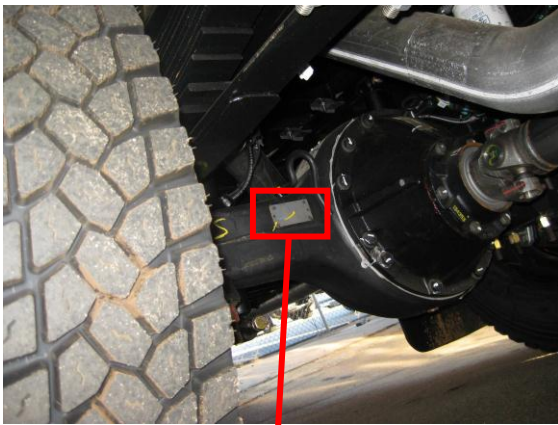

BLUE BIRD BODY COMPANY

P.O. Box 937 – 402 Blue Bird Blvd – Fort Valley, Georgia – (478) 825-2021



Service Manual

Single Reduction & Single Reduction with Differential Lock

AXSM0048

September 2008

15040S	23070S/D
17060S/D	23080S/D
19050S	23085S/D
19055S/D	23090S/D
19060S/D	23105S/D
20060S/D/R	26080S/D
21060S/D	26085S/D
21065S/D	26090S/D
21090S/D	26105S/D
22060S/D/R	30105S/D
22065S/D	
P20060S/D/R	
P22060S/D/R	

General Information

The description and specifications contained in this service publication are current at the time of printing. Dana reserves the right to discontinue or to modify its models and/or procedures and to change specifications at any time without notice.

Any reference to brand names in this publication is made simply as an example of the types of tools and materials recommended for use and should not be considered an endorsement. Equivalents, if available, may be used.

Important Notice

This symbol is used throughout this manual to call attention to procedures where carelessness or failure to follow specific instructions may result in personal injury and/or component damage.

Departure from the instructions, choice of tools, materials and recommended parts mentioned in this publication may jeopardize the personal safety of the service technician or vehicle operator.

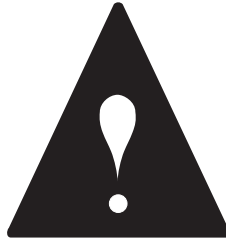

⚠ WARNING

Failure to follow indicated procedures creates a high risk of personal injury to the servicing technician.

⚠ CAUTION

Failure to follow indicated procedures may cause component damage or malfunction.

⚠ IMPORTANT

Highly recommended procedures for proper service of this unit.

NOTE: Additional service information not covered in the service procedures.

TIP: Helpful removal and installation procedures to aid in the service of this unit.

Always use genuine Spicer replacement parts.

Table of Contents

Table of Contents - Visual	1	Adjust Ring and Pinion Tooth Contact Pattern	33
Introduction	2	Adjust Pinion Position	34
Model Identification	3	Differential Lock Shifting Parts - Exploded View	35
Ring Gear and Pinion	4	Wheel Differential Locking Axles	36
Failure Analysis	5	Install and Adjust Differential Lock - Type 1 Axles	37
Prepare the Parts for Inspection	6	Shift Fork Adjustment - Type 1 Axles	39
Inspection	7	Install and Adjust Differential Lock - Type 2 Axles	40
Differential Carrier Assembly - Exploded View	8	Install and Adjust Wheel Differential Lock	42
Remove Differential Carrier	9	Install New Axle Housing Breather - (Metal and Plastic)	44
Install Differential Carrier	10	Axle Housing - Exploded View	45
Disassemble Carrier Assembly - (Rear Axles)	11	Inter-Axle Speed Sensor Parts - Exploded View	46
Rear Axle Pinion Assembly - Exploded View	13	Disassemble and Overhaul Inter-Axle Speed Sensor	47
Remove Pinion Assembly	14	Install Inter-Axle Speed Sensor	48
Disassemble and Overhaul Drive Pinion	15	Wheel End Seal Parts - Exploded View	49
Replace Pinion Bearing Cage Cups	17	Remove and Overhaul Wheel End Seal	50
Adjust Pinion Bearing Preload - (Trial Buildup)	18	Adjust Wheel Bearing	51
Adjust Pinion Bearing Preload - (Final Buildup)	20	Verify Wheel End-play Procedure	53
Install Drive Pinion Assembly	24	Lubricate Information	54
Install Pinion Oil Seal and Yoke	25	Proper Vehicle Towing	55
Wheel differential - Exploded View	26	Operate Wheel Differential Assembly	56
Remove Wheel Differential - (All Standard Models) ..	27	Wheel Differential Lock	57
Disassemble, Overhaul and Assemble Wheel Differential	28	Wheel Differential Lock Operation	58
Overhaul and Assemble Wheel Differential	29	Rear Drive Axle Parts - Exploded View	59
Measure and Adjust Carrier Assembly	31	Inter-Axle Speed Sensor Parts - Exploded View ..	60-61
Change Backlash Setting	32	Housing and Output Shaft Assembly Parts - Exploded View	62
		Fastener Torque Specifications	63-65

Table of Contents - Visual

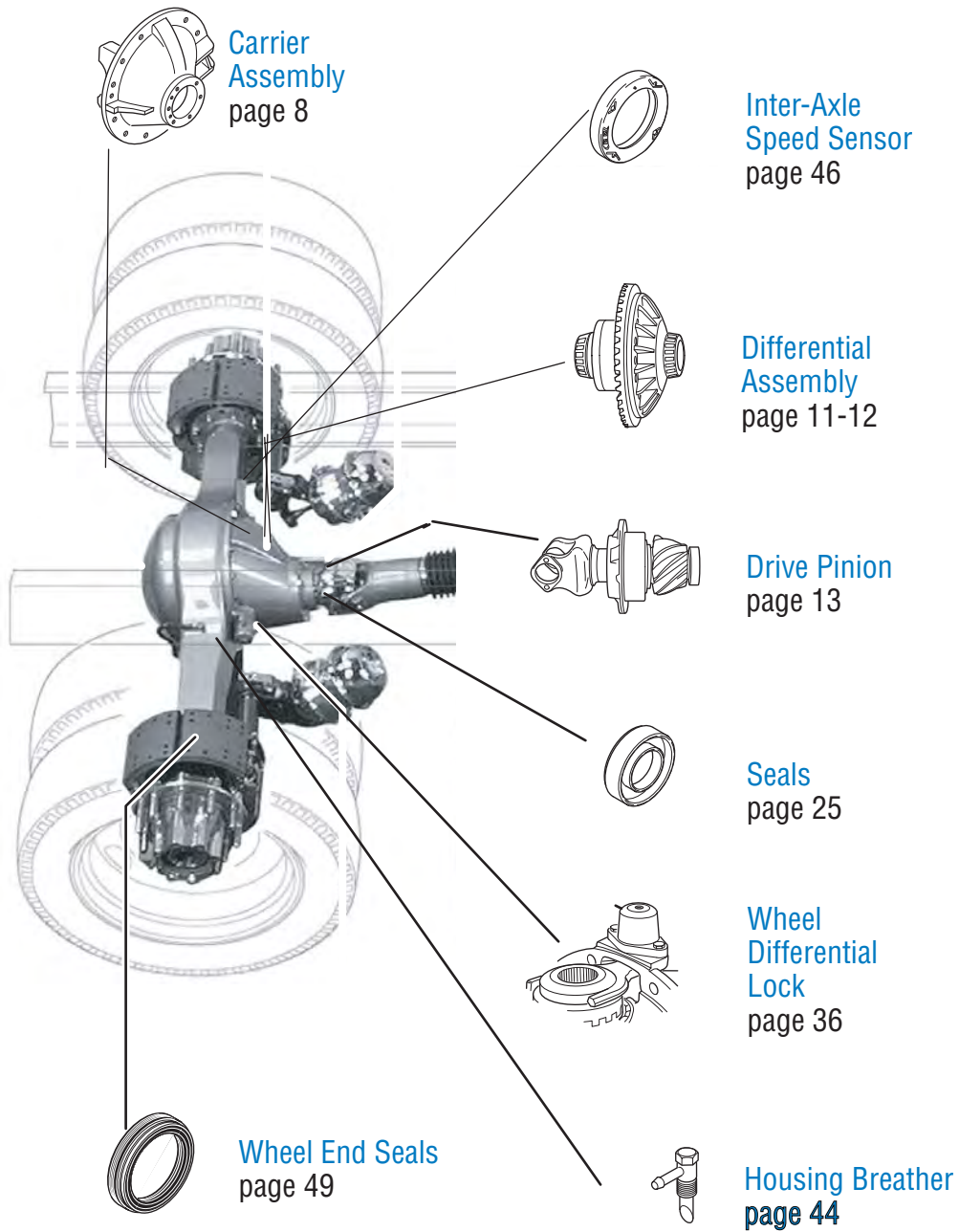

Introduction

Dana presents this publication to aid in maintenance and overhaul of Spicer single reduction drive axles. Instructions contained cover the models listed below. Their design is common, with differences in load capacity. Capacity variations are achieved by combining basic differential carrier assemblies with different axle housings, axle shafts and wheel equipment. The suffix letter “P” in the model number indicates a lube pump is standard. Pump models are equipped with a gerotor pump, designed to provide additional lubrication to the inter-axle differential and related parts.

Model Listing

The following models are included in this publication.

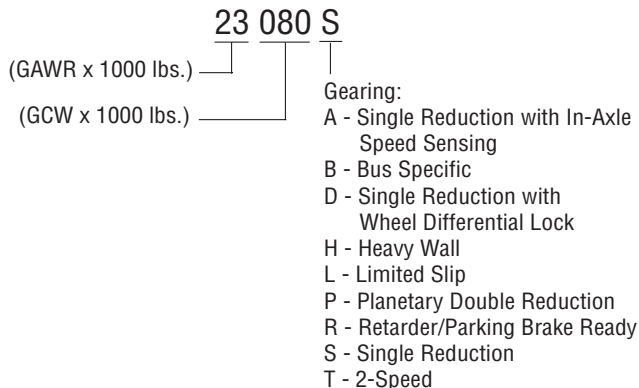

Spicer Single Reduction Axles		
With Standard Wheel Differential	With IASS	With Wheel Differential Lock
15040S	-	-
17060S	-	17060D
19050S	-	-
19055S	-	19055D
19060S	19060A	19060D
21060S	21060A	21060D
21065S	-	21065D
21080S	21080A	21080D
21090S	21090A	21090D
22060S	22060A	22060D
22065S	-	22065D
23070S	-	23070D
23080S	23080A	23080D
23085S	-	23085D
23090S	23090A	23090D
23105S	23105A	23105D
26080S	26080A	26080D
26090S	26090A	26090D
26105S	26105A	26105D
30105S	30105A	30105D
P22060S	-	P20060D
P22060S	-	P22060D

Model Identification

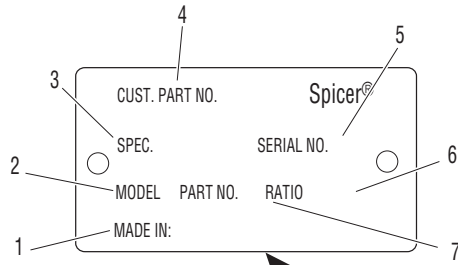

- 1 - Country of origin
- 2 - Axle model identification
- 3 - Specification number assigned to the axle built by Spicer. Identifies all component parts of the axle including special OEM requirements such as yoke or flanges.
- 4 - OEM part number assigned to the axle build
- 5 - Carrier assembly serial number assigned by the manufacturing plant
- 6 - Axle gear ratio
- 7 - Carrier assembly production or service part number

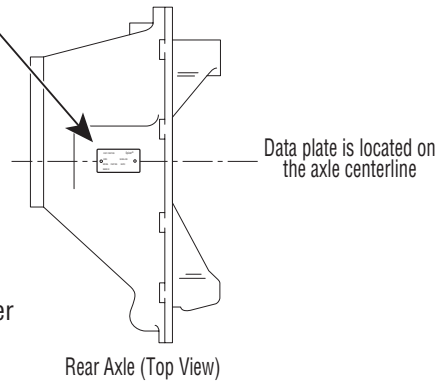

Parts Identification

Axle Housing

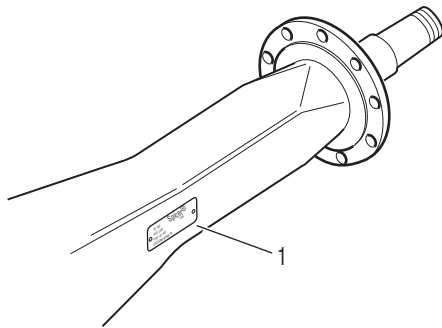

Axle Shaft

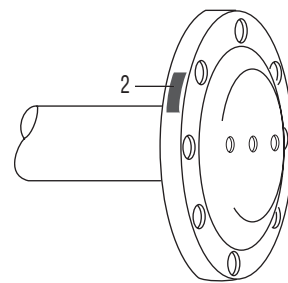

1 - ID Tag

2 - Axle shaft part number

Ring Gear and Pinion

Note: Ring gear and drive pinion are matched parts and must be replaced in sets.

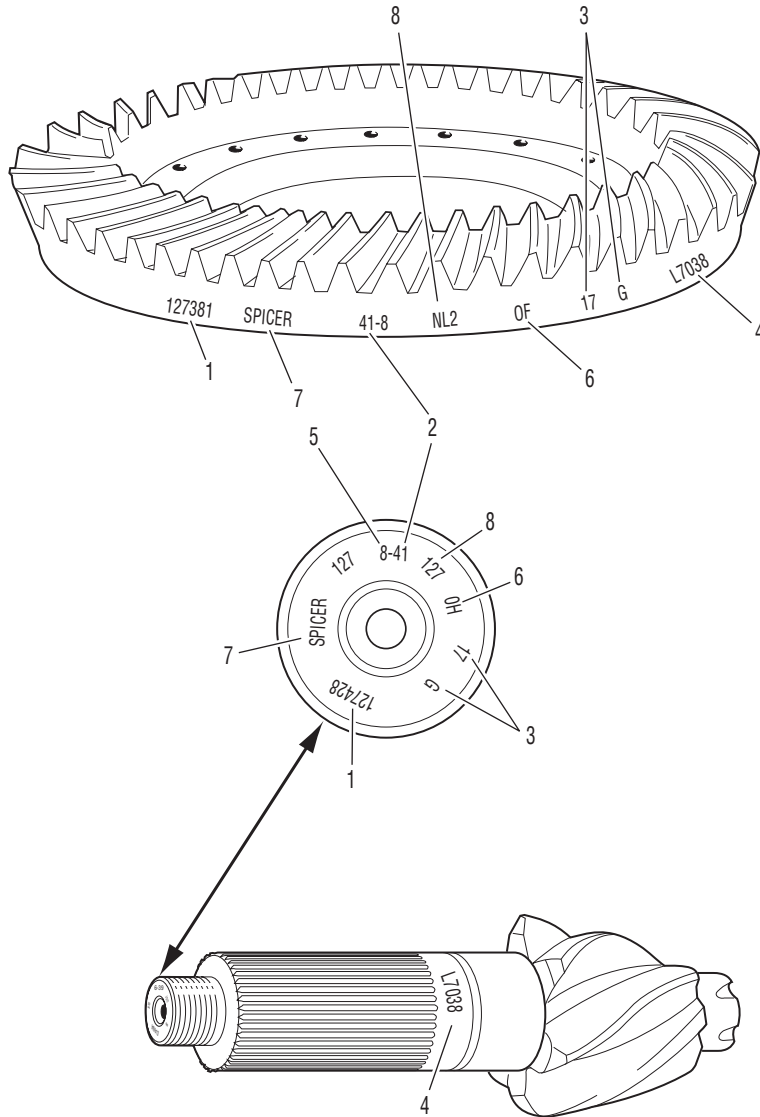

- 1—Part number
- 2—Number of ring gear teeth
- 3—Manufacturing numbers
- 4—Matching gear set number
- 5—Number of pinion teeth
- 6—Date code
- 7—Indicates genuine Spicer parts
- 8—Heat code

Failure Analysis

Failure analysis is the process of determining the original cause of a component failure in order to keep it from happening again. Too often, when a failed component is replaced without determining its cause, there will be a recurring failure. If a carrier housing is opened, revealing a ring gear with a broken tooth, it is not enough to settle on the broken tooth as the cause of the carrier failure. Other parts of the carrier must be examined. For a thorough understanding of the failure and possible insight into related problems, the technician needs to observe the overall condition of the vehicle.

No one benefits when a failed component goes on the junk pile with the cause unknown. Nothing is more disturbing to a customer than a repeat failure. Systematically analyzing a failure to prevent a repeat occurrence assures quality service by avoiding unnecessary downtime and further expense to the customer.

The true cause of a failure can be better determined by knowing what to look for, determining how a piece of the equipment was running and learning about previous problems. In the case of a rebuilt rear axle, mismatched gears may have been installed.

The more successful shops prevent repeat equipment failures by developing good failure analysis practices. Knowing how to diagnose the cause of a premature failure is one of the prerequisites of a good heavy-equipment technician.

How to Diagnose a Failure

The following five steps are an effective approach to good failure diagnostics.

1. Document the problem.
2. Make a preliminary investigation.
3. Prepare the parts for inspection.
4. Find the cause of the failure
5. Correct the cause of the problem.

Document the Problem

Here are some guidelines for starting to learn about a failure, including questions to ask:

- Talk to the operator of the truck.
- Look at the service records.
- Find out when the truck was last serviced.
- Ask: In what type of service is the truck being used?
- Ask: Has this particular failure occurred before?
- Ask: How was the truck working prior to the failure?

You need to be a good listener. Sometimes, insignificant or unrelated symptoms can point to the cause of the failure.

- Ask: Was the vehicle operating at normal temperatures?
- Ask: Were the gauges showing normal ranges of operation?
- Ask: Was there any unusual noise or vibration?

After listening, review the previous repair and maintenance records. If there is more than one driver, talk to all of them and compare their observations for consistency with the service and maintenance records. Verify the chassis Vehicle Identification Number (VIN) number from the vehicle identification plate, as well as the mileage and hours on the vehicle.

Make a Preliminary Investigation

These steps consist of external inspections and observations that will be valuable when combined with the results of the parts examination.

- Look for leaks, cracks or other damage that can point to the cause of the failure.
- Make note of obvious leaks around plugs and seals. A missing fill or drain plug would be an obvious cause for concern.
- Look for cracks in the carrier housing (harder to see, but sometimes visible).
- Does the general mechanical condition of the vehicle indicate proper maintenance or are there signs of neglect?
- Are the tires in good condition and do the sizes match?
- If equipped with a torque-limiting device, is it working properly?

During the preliminary investigation, write down anything out of the ordinary for later reference. Items that appear insignificant now may take on more importance when the subassemblies are torn down.

Prepare the Parts for Inspection

After the preliminary investigation, locate the failure and prepare the part for examination. In carrier failure analysis, it may be necessary to disassemble the unit.

- When disassembling subassemblies and parts, do not clean the parts immediately since cleaning may destroy some of the evidence.
- When tearing down the drive axle, do it in the recommended manner. Minimize any further damage to the unit.
- Ask more questions when examining the interior of the carrier. Does the lubricant meet the manufacturer specifications regarding quality, quantity and viscosity? As soon as you have located the failed part, take time to analyze the data.

Find the Cause of the Failure

Here begins the real challenge to determine the exact cause of the failure. Keep in mind that there is no benefit to replacing a failed part without determining the cause of the failure. For example, after examining a failed part and finding that the failure is caused by a lack of lubrication, you must determine if there was an external leak. Obviously, if there is an external leak, just replacing the failed gear is not going to correct the situation.

Another important consideration here is to determine the specific type of failure which can be a valuable indicator for the cause of failure. The following pages show different types of failures and possible causes. Use this as a guide in determining types of failures and in correcting problems.

Correct the Cause of the Problem

Once the cause of the problem has been determined, refer to the appropriate service manual to perform the repairs.

Inspect Assembly

Clean

1. Wash steel parts with ground or polished surfaces in solvent. There are many suitable commercial solvents available. Kerosene and diesel fuel are acceptable.

⚠ WARNING

Gasoline is not an acceptable solvent because of its extreme combustibility. It is unsafe in the workshop environment.

2. Wash castings or other rough parts in solvent or clean in hot solution tanks using mild alkali solutions.

Note: If a hot solution tank is used, make sure parts are heated thoroughly before rinsing.

3. Rinse thoroughly to remove all traces of the cleaning solution.
4. Dry parts immediately with clean rags.
5. Oil parts.
 - If parts are to be reused immediately: Lightly oil.
 - If parts are to be stored: Coat with oil, wrap in corrosion resistant paper and store in a clean, dry place.

Inspect Axle Housing

Axle housing inspection and repairs are limited to the following checks or repairs:

- Visually inspect axle housing for cracks, nicks and burrs on machined surfaces.
- Check carrier bolt holes and studs for foreign material.
- Replace damaged fasteners. Look for loose studs or cross threaded holes.

⚠ CAUTION

Any damage which affects the alignment or structural integrity of the housing requires housing replacement. Do not repair by bending or straightening. This process can affect the material's properties and cause it to fail completely under load.

- Check all seals and gaskets.

Note: Replace conventional gaskets with silicone rubber gasket compound (included in many repair kits). The compound provides a more effective seal against lube seepage and is easier to remove from mating surfaces when replacing parts.

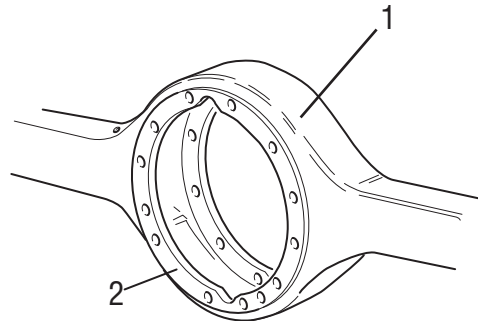

- 1 - Axle housing
- 2 - Machined surface

Inspect all steel parts for:

- Notches, visible steps or grooves created by wear.
- Pitting or cracking along gear contact lines.
- Scuffing, deformation or discolorations. These are signs of excessive heat in the axle and are usually related to low lubrication levels or improper lubrication practices.

In addition, inspect the following for damage:

- Differential gearing.
- Bearings for loose fit on drive pinion, pilot bearing, and differential bearings.
- All fasteners for rounded heads, bends, cracks or damaged threads.
- Inspect machined surfaces of cast or malleable parts. They must be free of nicks, burrs, cracks, scoring, and wear.
- Look for elongation of drilled holes, wear on surfaces machined for bearing fits and nicks or burrs in mating surfaces.

Inspect Primary Gearing

Before reusing a primary gear set, inspect teeth for signs of excessive wear. Check tooth contact pattern for evidence of incorrect adjustment.

Differential Carrier Assembly - Exploded View

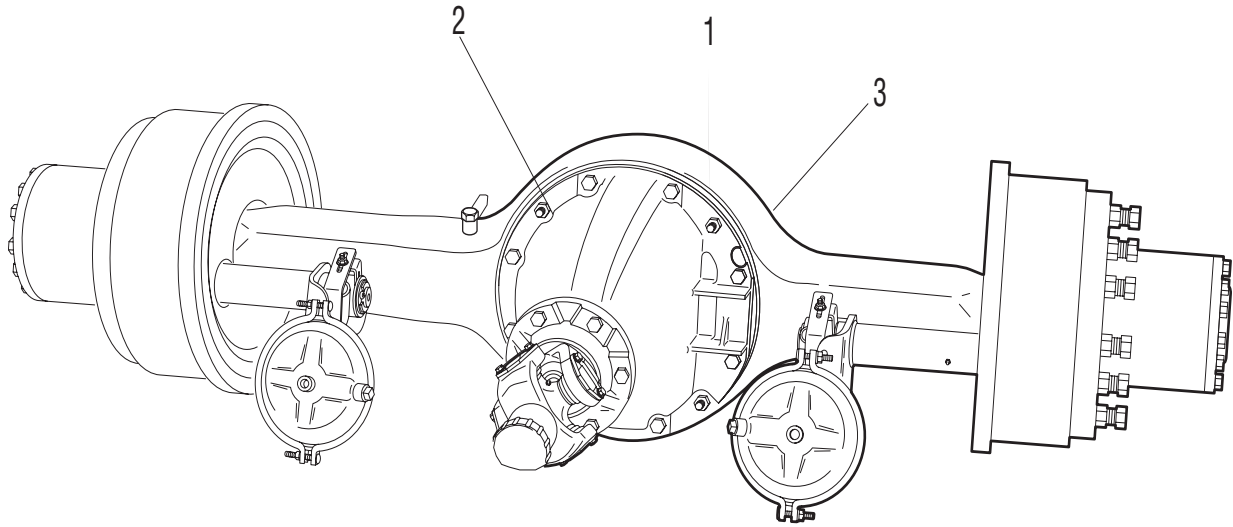

- 1 - Carrier Fasteners
- 2 - Carrier Assembly
- 3 - Single Axle Assembly

Remove Differential Carrier

Procedure -

1. Block the vehicle.
2. Drain axle lubricant.
3. Disconnect main driveline.
4. Disconnect differential lockout air line.
5. Disconnect lead wires to the selector switch and air line at shift cylinder.
6. Remove axle shafts.

Diff-Lock Models

- For removal of the locking wheel differential carrier assembly, the differential lock must be engaged and held in the engaged position. This can be accomplished by one of two methods; either engage via air pressure or engage manually.

Engage via Air Pressure

- Using an auxiliary air line, apply 80–120 PSI air pressure to shift cylinder air port to engage clutch.

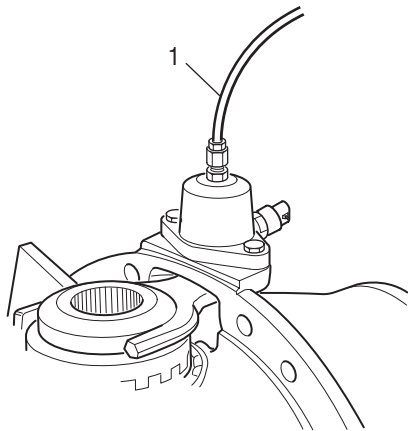

1—Connect 80-120 PSI air line to cylinder port

Engage Manually

- Install a .250 – 18 NPTF bolt over 1.5" long in the cylinder air port to manually engage the clutches. GM models require a M12 X 1.5 X 38mm bolt.

Note: Hand-tighten the bolt, over-torquing may cause damage to the shift unit. To facilitate hand-tightening, coat bolt threads with axle lube.

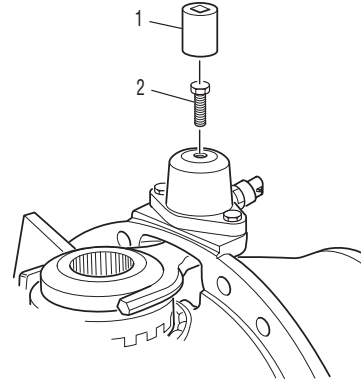

1—Hand tighten with socket

2—M12 x 1.5 x 38mm bolt – GM only .250 – 18 NPTF – all models except GM

Note: With either method, the axle shaft may have to be rotated to permit the clutch to become engaged.

WARNING

Do not lie under carrier after fasteners are removed. Use transmission jack to support differential carrier assembly prior to loosening fasteners

7. To remove axle shaft, remove axle stud nuts. (If used, remove lock washers and taper dowels.)
8. Remove axle shafts.

Note: All models in this publication use axle shafts with unequal lengths. Axle shafts may also be location specific with various wheel equipment. Do not misplace axle shafts from their intended location. Identify left and right shafts for reference during reassembly.

TIP: If necessary, loosen dowels by holding a brass drift in the center of the shaft head and strike drift a sharp blow with a hammer.

CAUTION

Do not strike the shaft head with a steel hammer. Do not use chisels or wedges to loosen shaft or dowels.

9. Remove carrier cap screws, nuts and lock washers.
10. Remove differential carrier assembly.

Install Differential Carrier

▲ IMPORTANT

Before installing carrier assembly, inspect and thoroughly clean interior of axle housing using an appropriate solvent and clean rag.

Procedure -

1. Apply Spicer approved RTV compound on axle housing mating surface as shown in the illustration. Completely remove all old gasket material prior to applying new material. Compound will set in 20 minutes. Install carrier before compound sets or reapply.

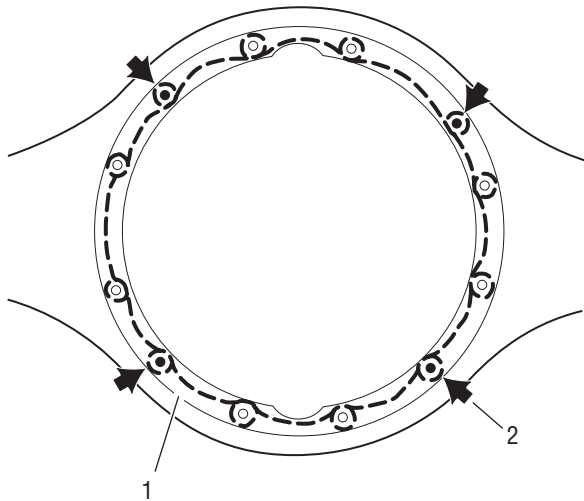

1— Apply silicone gasket in this pattern

2— Common stud locations

TIP: To assist in installing complete differential carrier use two pieces of threaded rod threaded into carrier cap screw holes. Rod should be approximately 6" long. Use these to pilot the carrier into the housing.

2. Install carrier to housing, washers, cap screws and nuts. Torque to proper specifications. See torque chart of page 66.
3. Install axle shafts and axle stud nuts (if used, also install lock washers and tapered dowels).
4. Add axle lubricant. Fill to bottom of filler hole.
5. **Rear Only:** Connect inter-axle driveline, making sure all yokes are in phase. Lubricate U-joints.

Disassemble Carrier Assembly - (Rear Axles)

Note: For models having the wheel differential lock option or a carrier thrust bolt follow the steps below. These parts must be removed first before further removal of the wheel differential and/or pinion can take place.

Procedure - Remove Wheel Differential - Models with Wheel Differential Lock

1. For ease of servicing, mount differential carrier in stand with differential lock facing up.

Note: To remove the pinion assembly, the shift fork, clutch hand wheel Diff. assembly, must be removed from carrier. See instructions below.

2. Remove shift cylinder mounting screws, then lift shift cylinder, piston and o-ring assembly off carrier and end of push rod.

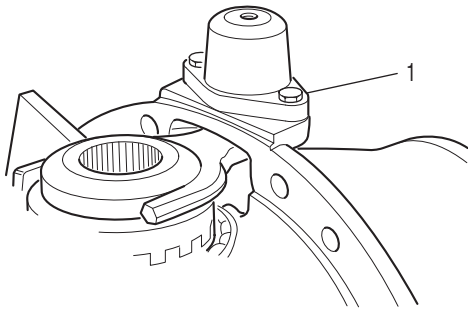

1 - Shift cylinder

3. To disassemble shift cylinder for inspection, first remove or back off actuator switch. The piston and o-ring assembly can be removed by inserting a pencil-size tool through the cylinder air port.
4. Grasp push rod end and pull it out of the shift fork, spring and carrier.

Note: When the push rod is disengaged from the shift fork, the fork and sliding curvic clutch assembly can be removed from carrier.

Note: Do not disassemble shift fork from the sliding curvic clutch unless parts replacement is necessary. To disassemble, use pin punch to remove spring pin from long leg of fork. The fork can now be disengaged from the clutch.

5. Remove the snap ring, then lift fixed curvic clutch off differential case hub spline. Further disassembly of carrier is the same for axles without differential lock.

Procedure - Models with Ring Gear Thrust Bolt

1. Loosen thrust bolt jam nut.

Note: If the carrier model has a ring gear thrust bolt installed, it must be backed away from the ring gear before you can remove the wheel differential.

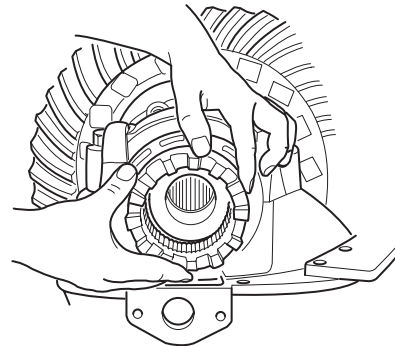

2. Back out thrust bolt from the carrier until the end of the bolt is flush with the inside of the carrier casting. This will allow enough clearance between the ring gear and the carrier pilot web.

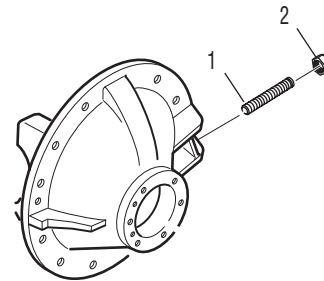

1 - Thrust bolt

2 - Jam nut

Procedure - Remove Wheel Differential - All Standard Models

1. Mount differential carrier in repair stand.

Note: Omit this step if the gear set is to be replaced. If gear set is to be reused, check tooth contact pattern and ring gear backlash before disassembling differential carrier. When checking backlash, a yoke or helical gear must be installed and torqued to get an accurate reading. Best results are obtained when established wear patterns are maintained in used gearing.

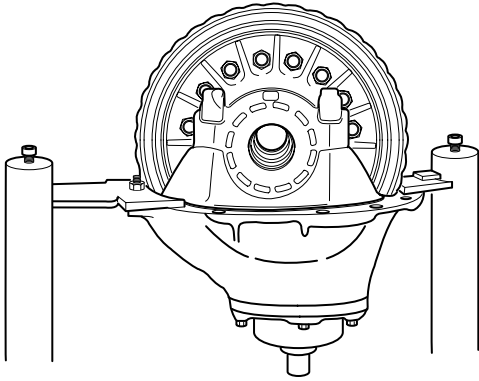

2. If reusing gear set, also punch mark bearing adjusters for reference during assembly.

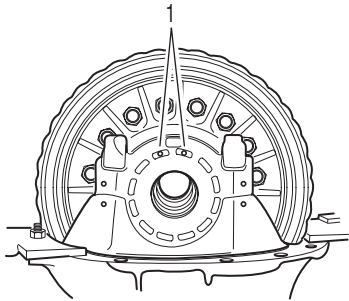

1 - Thrust bolt

3. Remove cap screws, flat washers and bearing caps. Loosen bearing adjusters and remove adjusters and bearing cups.

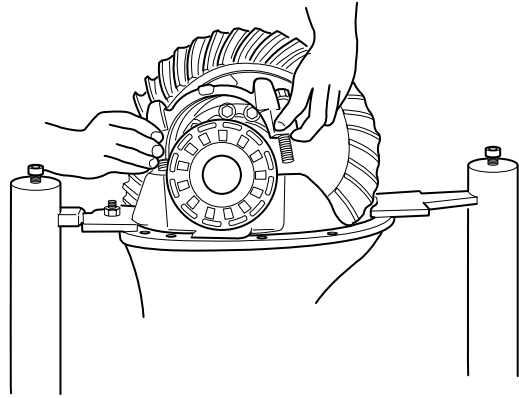

4. Using a chain hoist, lift ring gear and differential assembly out of carrier.

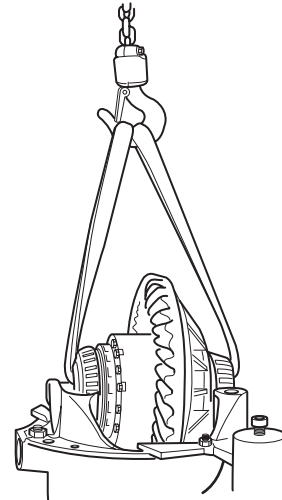

Rear Axle Pinion Assembly - Exploded View

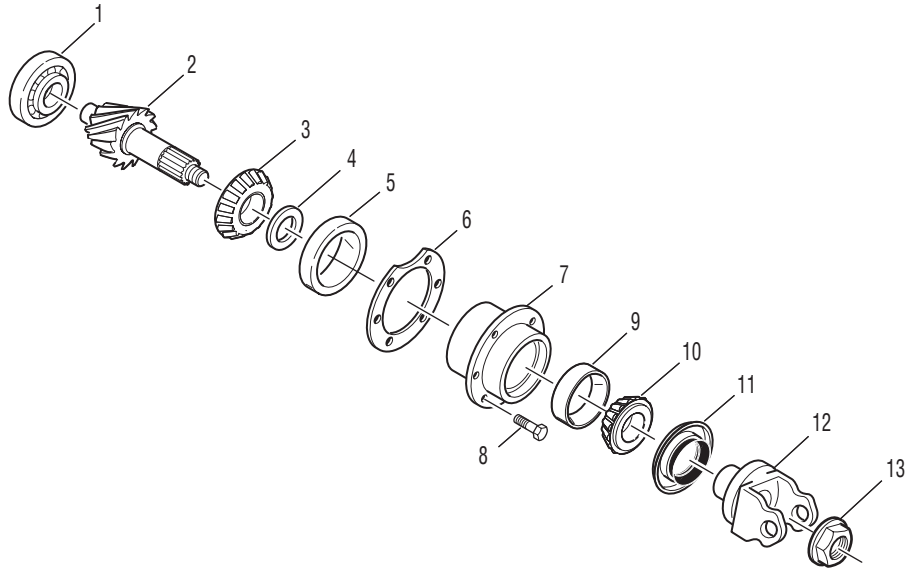

- 1—Pinion pilot bearing
- 2—Pinion
- 3—Pinion bearing cone - inner
- 4—Pinion bearing spacer
- 5—Pinion bearing cup - inner
- 6—Shim
- 7—Pinion bearing cage
- 8—Cap screw
- 9—Pinion bearing cup - outer
- 10—Pinion bearing cone - outer
- 11—Oil seal
- 12—Yoke
- 13—Pinion nut

Remove Pinion Assembly

Procedure -

1. Remove pinion bearing cage cap screws. Remove pinion and cage assembly from carrier. Remove shim pack.

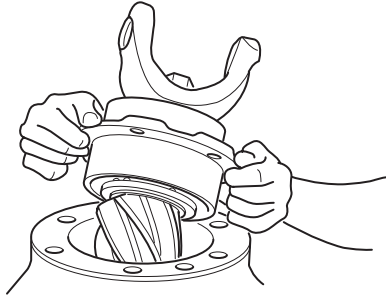

⚠ WARNING

Do not allow pinion to drop on hard surface

If gear set is to be reused, keep pinion bearing cage shim pack intact for use in reassembly. If the original shims cannot be reused, record the number and size of shims in the pack.

Disassemble and Overhaul Drive Pinion

The following procedures cover both forward and rear differential drive carrier disassembly.

Rear Axle Pinion Yoke

1. Remove yoke.

CAUTION

If pinion nut was not loosened during earlier disassembly, clamp assembly in vise jaws, use brass pads to prevent damage.

2. Loosen and remove pinion nut and flat washer. Remove yoke from pinion using an appropriate tool.

Forward and Rear Axle Pinion Bearing Cage

3. Press pinion out of bearing cage and bearing cone.

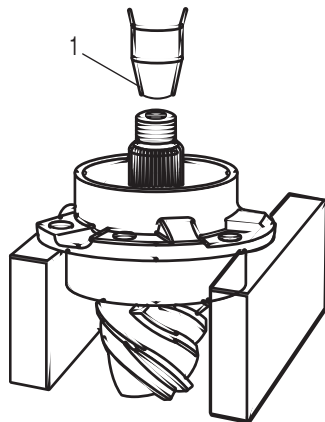

1 - Press Ram

Rear Axle Pinion Oil Seal and Outer Bearing Cone

4. Remove oil seal and bearing cone from cage. Discard oil seal. Remove bearing cups with suitable puller.

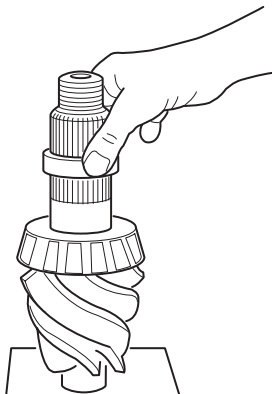

5. Remove bearing spacer from pinion.
6. Remove pilot bearing from pinion using a split-type puller. Use two procedure steps to remove each bearing.
 - a. Mount puller vertically to separate the bearing. This action will force puller halves under bearing and start moving bearing off pinion.

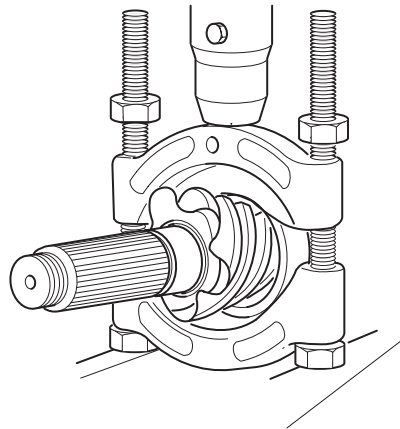

- b. Mount puller horizontally to press pinion out of bearing.

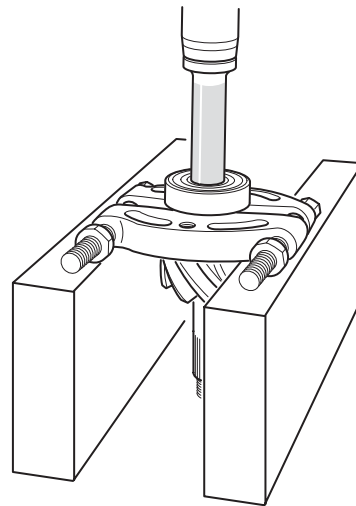

7. Remove inner bearing cone from pinion using a split-type puller. Use two procedure steps to remove each bearing.

- a. Mount puller vertically to separate the bearing. This action will force puller halves under bearing and start moving bearing off pinion.

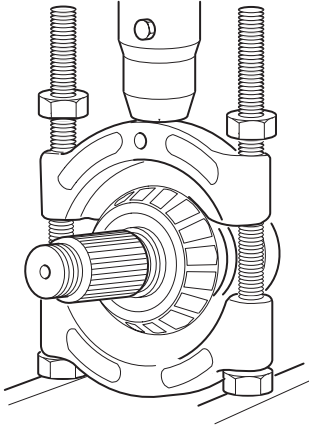

- b. Mount puller horizontally to press pinion out of bearing.

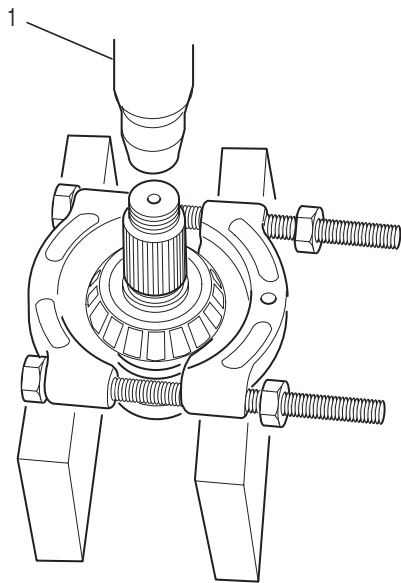

1 - Press

Replace Pinion Bearing Cage Cups

1. Remove cups.

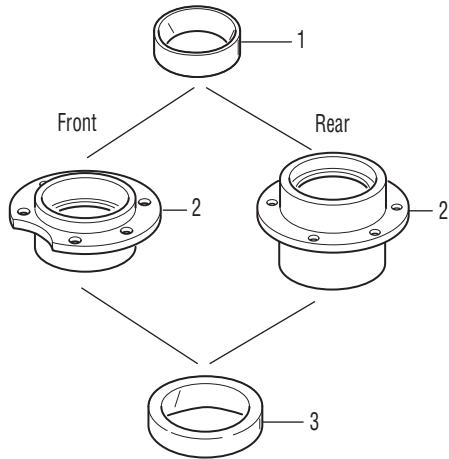

- 1 - Cup (Outer)
- 2 - Bearing cage
- 3 - Cup (inner)

4. Seat cups securely to shoulder. Check clearance between cup and bearing cage. Must be less than .001".



- 2. Clean and inspect bearing cages for damage, nicks and burrs.
- 3. Install inner and outer pinion bearing cups. Use a press and an appropriate drive sleeve. Make certain bearing cup is evenly and firmly seated.

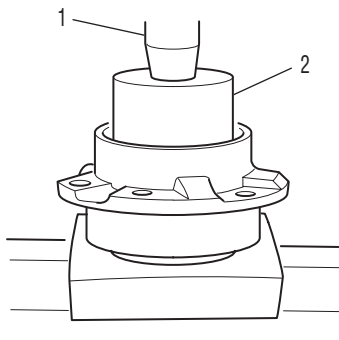

- 1 - Press ram
- 2 - Sleeve must apply pressure to back face of outer bearing cone

Adjust Pinion Bearing Preload - (Trial Buildup)

1. Assemble pinion bearing cage, bearings, spacer and spacer washer (without drive pinion or oil seal). Center bearing spacer between two bearing cones. Lubricate bearing cups and cones.

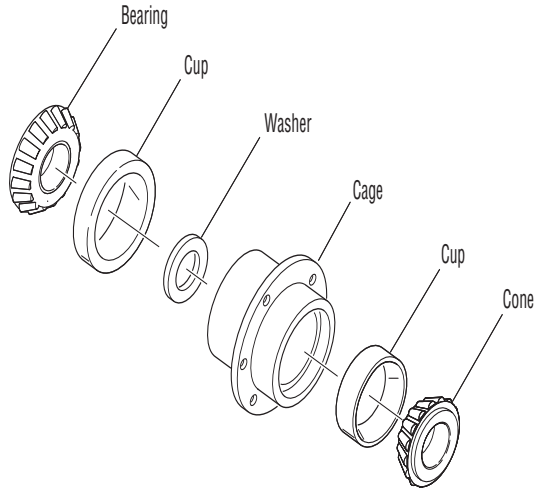

Note: When new gear set or pinion bearings are used, select nominal size spacer from the specification chart below. If original parts are used, use spacer removed during disassembly.

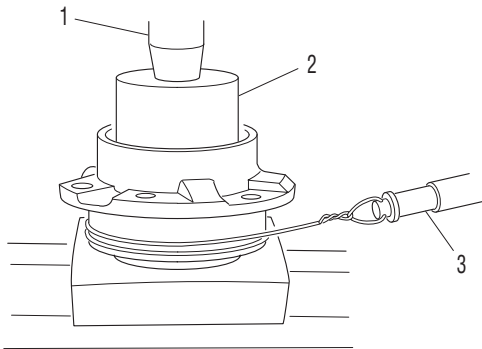

- 1 - Press ram
- 2 - Sleeve must apply pressure to back face of outer bearing cone
- 3 - Spring scale

2. With the bearings well lubricated, place the assembly in the press. Position sleeve so load is applied directly to the back-face of the outer bearing cone.

3. Rotate pinion cage while applying press load to the assembly and check rolling torque. Wrap soft wire around the bearing cage, attach spring scale and pull. Preload is correct when torque required to rotate the pinion bearing cage is within the specifications listed in the chart below.

CAUTION

Read only the torque value after the bearing cage starts to rotate.

4. If necessary, adjust pinion bearing preload by changing the pinion bearing spacer. A thicker spacer will decrease preload. A thinner spacer will increase preload.

Note: Once correct bearing preload has been established, note the spacer size used. Select a spacer .001" larger for use in the final pinion bearing cage assembly. The larger spacer compensates for slight "growth" in the bearings which occurs when they are pressed on the pinion shank.

CAUTION

Do not assume that all assemblies will retain proper preload once bearings are pressed on pinion shank. FINAL PRELOAD TEST MUST BE MADE IN EVERY CASE.

Pinion Assembly

Axle Model	Nominal Bearing Spacer Thickness		Press Loads		Spring Scale Adjustments*	
	in.	mm	Tons	Metric Tons	lbs.	N•m
15040, 19050, 19055	.703	17.86	12 - 13	11 - 12	4 - 7	17 - 33
17060, 19060, 21060, 22060	.638	16.21	14 - 15	13 - 14	4 - 8	17 - 35
21065, 22065	.720	18.29	15 - 16	14 - 15	3 - 7	15 - 30
21080, 21090, 23070, 23080, 23085, 23090, 26080, 26085, 26090	.672	17.07	18 - 19	16 - 17	3 - 6	12 - 24
23105, 26105, 30105	.527	13.40	18 - 19	16 - 17	3 - 6	12 - 24

Note: *Spring scale reading (w/o pinion seal) torque to rotate bearing cage 10 - 20 lbs.in. (1.1-2.3 N•m).

Adjust Pinion Bearing Preload - (Final Buildup)

Note: On rear axles, do not install oil seal in cage until bearing preload is correctly adjusted.

▲ IMPORTANT

After bearing cups are installed, preselect pinion bearing spacer using the “trial buildup” procedure.

Note: During pinion bearing installation, locate each part in same position that was used in “trial buildup” preload test.

Procedure -

1. Press inner bearing cone Pinion Assembly on pinion.

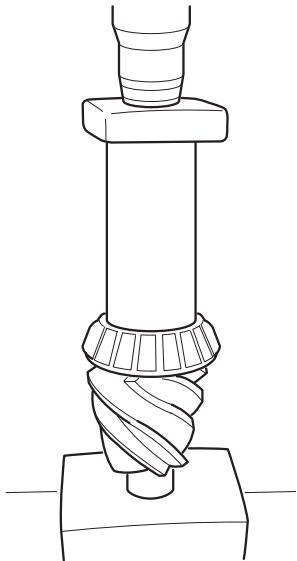

▲ CAUTION

To prevent bearing damage, use suitable sleeve that only contacts inner race of bearing cone

2. Install preselected bearing spacer.

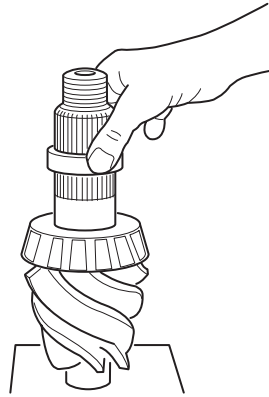

3. Install bearing cage on drive pinion.

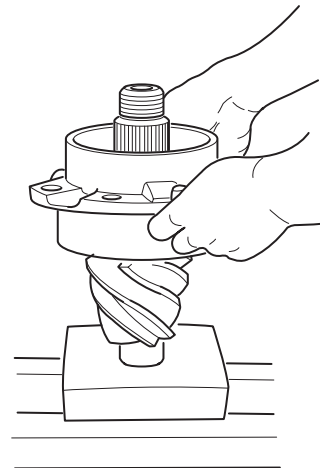

4. Press outer bearing cone on pinion.

CAUTION

To prevent bearing damage, spin cage while pressing outer bearing on.

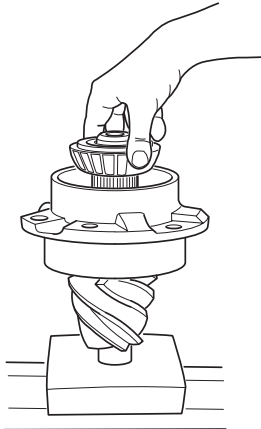

5. Apply clamp load to the pinion bearing cage assembly. Either install the yoke (or helical gear) and torque the pinion nut to specifications or use the press to simulate nut torque (see chart below).

*Torque nut to 840 ft.lbs. (1,140 N•m), then continue tightening nut to align nut slot to nearest hole in pinion shank.

Note: *Specifications for final Pinion Bearing Preload Test. Torque to rotate bearing cage 15 -35 in.lbs. (1.7 - 4.0 N•m)

Vise Method

- a. If the yoke and nut are used, mount the assembly in a vise, clamping yoke firmly.

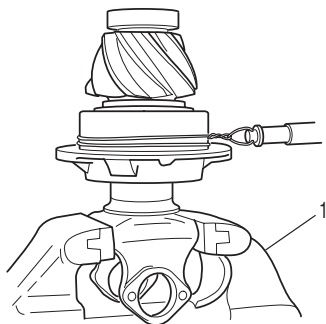

1 - Vise

Press Method

- a. If a press is used, position a sleeve or spacer so that load is applied directly to the back face of the outer bearing cone.

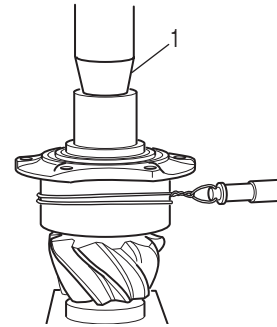

1 - Press

6. Measure Pinion Bearing Preload: Use a spring scale to test the assembly rolling torque. To use the spring scale, wrap flexible wire around the bearing cage, attach the scale and pull. Preload is correct when torque required to rotate the pinion bearing cage is within the specifications Listed in the previous chart.

CAUTION

Read only the torque value after the bearing cage starts to rotate.

7. Adjust Pinion Bearing Preload: If necessary, adjust pinion bearing preload. Disassemble the pinion bearing cage as recommended in this manual and change the pinion bearing spacer. A thicker spacer will decrease preload. A thinner spacer will increase preload.

Axle Model	Pinion Nut Torque		Press Loads		Spring Scale Adjustments	
	Lbs.- ft.	N•m	Tons	Metric Tons	lbs.	N•m
15040, 19050, 19055	376 - 461	510 - 625	12 - 13	11 - 12	6 - 13	25 - 58
17060, 19060, 21060, 22060	575 - 703	780 - 953	14 - 15	13 - 14	6 - 14	25 - 60
21065, 22065, 22080	542 - 664	735 - 900	15 - 16	14 - 15	5 - 11	23 - 52
21080, 21090, 23070, 23080, 23085, 23090, 26080, 26085, 26090,	789 - 966	1070 - 1310	18 - 19	16 - 17	4 - 10	18 - 43
23105, 26105, 30105	840 - 1020	1140 - 1383	18 - 19	16 - 17	4 - 10	18 - 43

CAUTION

Use the correctly sized spacer. Do not use shim stock or grind spacers. These practices can lead to loss of bearing preload and gear or bearing failure

8. Press pilot bearing on pinion.

CAUTION

To prevent bearing damage, use suitable sleeve that only contacts the inner race of bearing cone.

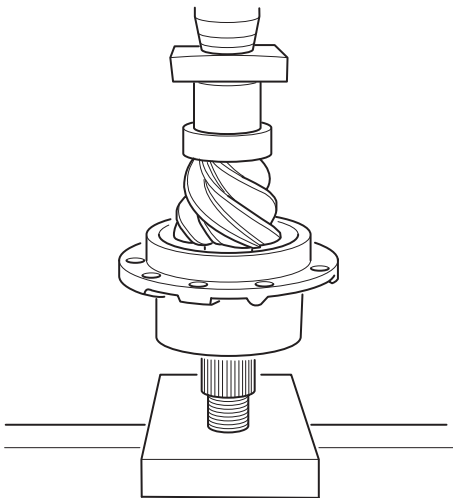

9. Stake pilot bearing using staking tool. This is essential to retain the bearing.

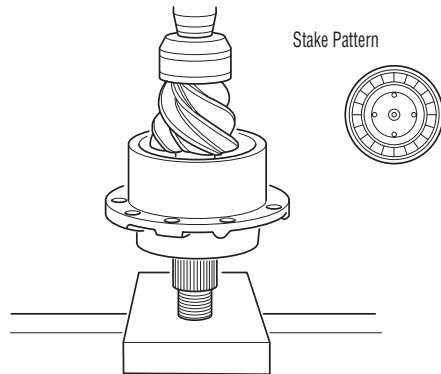

10. With pinion installed and bearing preload adjustment complete, install oil seal. Use properly sized installation tool as described on the next page to prevent distortion.

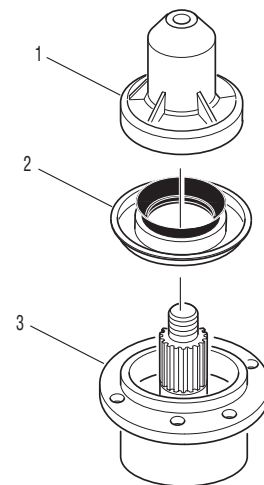

- 1 - Tool
- 2 - Seal
- 3 - Bearing cage

11. Prior to installation of yoke, make sure yoke is clean and dry.

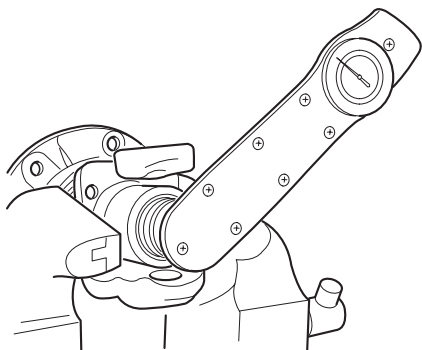

12. Install yoke.
13. Install yoke nut using one of the following options:
 - Install a new nut with the pre-applied thread adhesive compound. Tighten the nut to the specified torque as specified in the back of this publication.
 - If a new nut with pre-applied thread adhesive compound is unavailable, apply “Loctite 277” or “271” to the nut along two flats, for at least two flats (120°) of the nut midway through the thickness.

▲ IMPORTANT

Follow the instructions specified by the thread adhesive manufacturer when applying thread adhesive compound.

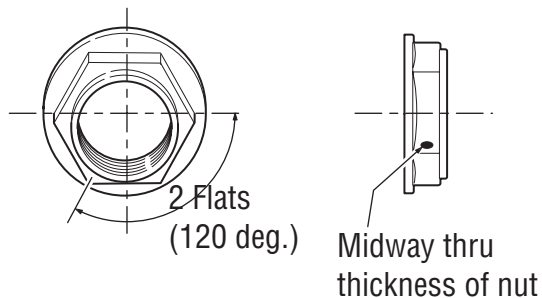

Note: Use of a torque multiplier is recommended.

TIP: If you can't get the correct torque on yoke nut, try torquing the nut with the truck wheels on the ground and with the axle shafts installed.

Install Drive Pinion Assembly

Procedure -

1. Place shim pack on carrier making sure lube holes are clear.

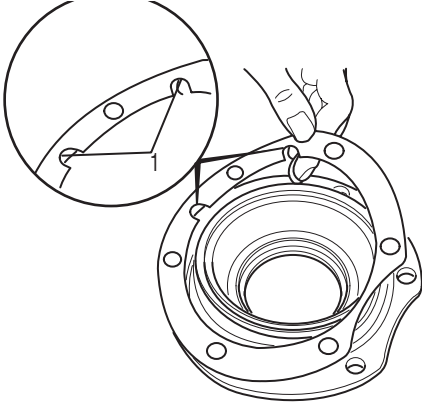

1 - lube slots

Note: If gear set is to be reused, install same quantity and size of shims removed during disassembly. When installing a new gear set, use nominal shim pack indicated.

2. Install pinion assembly. Install bearing cage cap screws and lock washers. Torque to proper specifications as outlined in back of this publication.



Nominal Shim Pack	
15040, 19050, 19055, 21065, 21090, 22065, 23070, 23080, 23085, 23090, 26080, 26085, 26090	.024 in (.61 mm)
17060, 19060, 21060, 22060	.023 in (.58 mm)
23105, 26105, 30105	.021 in (.53 mm)

Install Pinion Oil Seal and Yoke

1. With pinion bearing preload adjustment complete, install oil seal. If available, use a properly sized installation tool to install the oil seal. Otherwise, use a press and properly sized sleeve to prevent distortion or contact with seal lips during installation (see illustration).

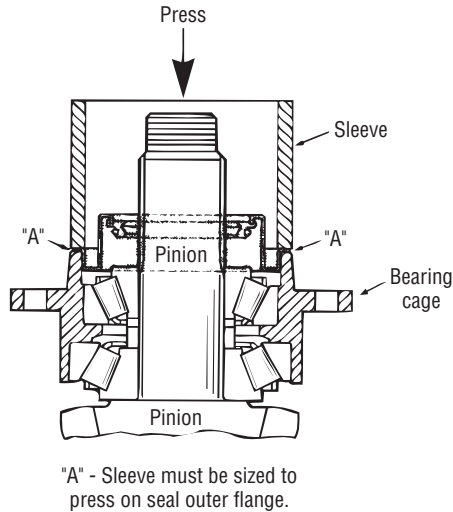

2. Make sure yoke is clean and dry. Install yoke and nut (or nut washer on some models). Tighten nut to correct torque (see torque chart).

Note: After tightening nut, recheck pinion bearing rolling torque, then proceed with pinion installation in carrier.

Yoke Reuse Guidelines

CAUTION

Do not use the yoke if it has any damage on the seal surface (nicks or scratches).

The surface of the yoke and the lips of the seal form a critical interface which retains the axle's lubricant while sealing the axle from outside contaminants. The condition of the yoke hub's surface is a very important factor in determining seal life.

Carefully inspect the seal surface area of the yoke hub for signs of wear and damage. Do not reuse the yoke if there is noticeable wear such as heavy grooving, beyond normal polishing from the seal lips.

Note: Do not rework the yoke with abrasives such as emery paper or crocus cloth. Clean the surface of the yoke as necessary using chemical cleaners. Remove all trace of the chemicals from the yoke after cleaning.

Note: Do not use wear sleeves. Wear sleeves increase the yoke hub surface diameter and cause premature seal wear and repeat seal failure.

Seal Replacement

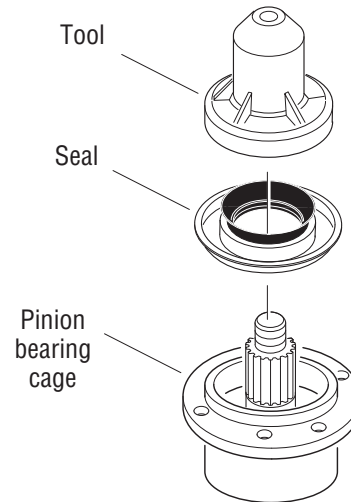

Note: Spicer strongly recommends using seal drivers when installing new seals. Use the proper driver to ensure the seal is square and installed to the proper depth.

CAUTION

Oil seals can be easily damaged prior to installation. Use care when handling the new seal to prevent damage or contamination. Leave the seal in its package until installation. On new yokes, leave the protector on the yoke until it is installed on the shaft to prevent damage or contamination.

Wheel Differential - Exploded View

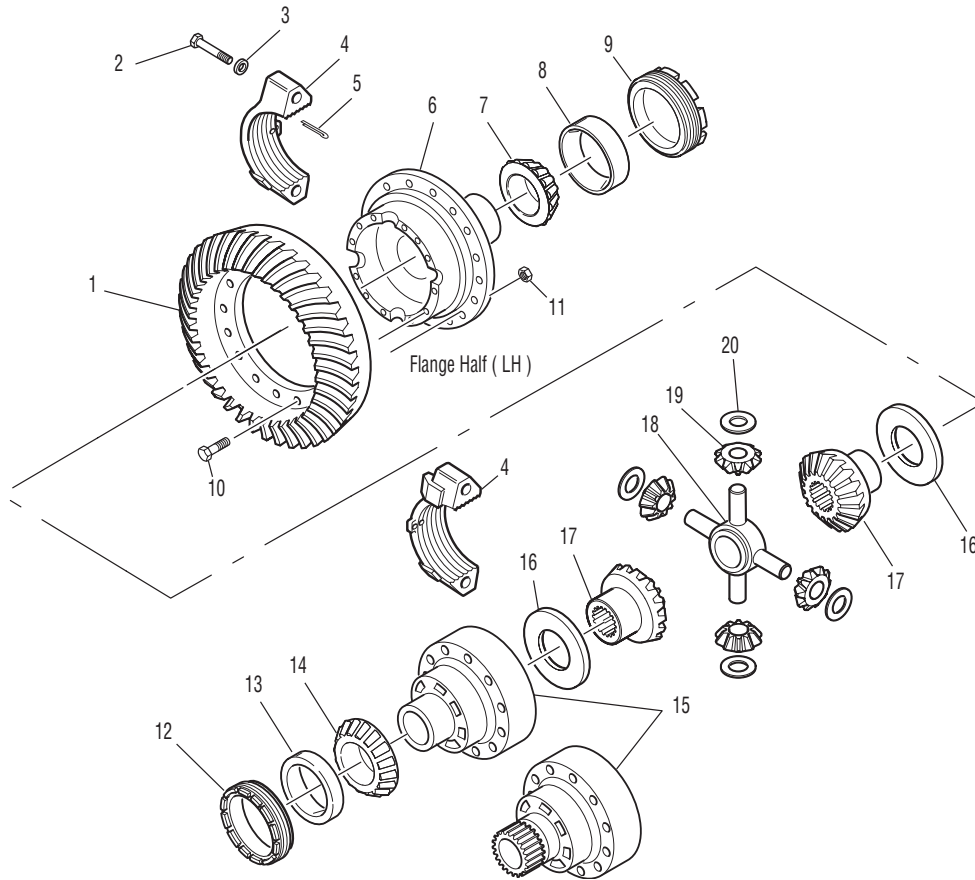

- | | |
|---|-------------------------------|
| 1. Ring Gear | 17. Side gear |
| 2. Capscrew | 18. Diff. spider |
| 3. Flat washer | 19. Side pinion |
| 4. Diff. carrier bearing caps | 20. Side pinion thrust washer |
| 5. Cotter pin | |
| 6. Diff. case - LH (flange half) | |
| 7. Bearing cone - flange half | |
| 8. Bearing cup - flange half | |
| 9. Diff. brg. adjuster - flange half | |
| 10. Bolt | |
| 11. Nut | |
| 12. Diff. bearing adjuster - plain half | |
| 13. Bearing cup - plain half | |
| 14. Bearing cone - plain half | |
| 15. Diff. case - RH (plain half) | |
| 16. Side gear thrust washer | |

No-SPIN[®] Differential

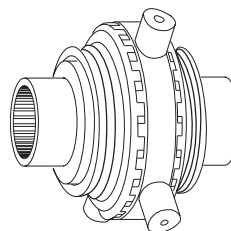

(Optional)

TrueTrac

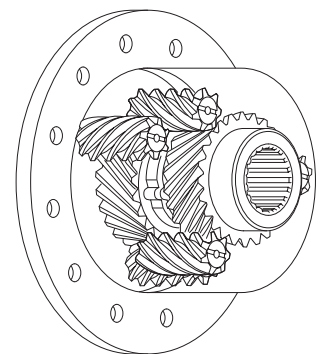

Remove Wheel Differential - (All Standard Models)

Note: Omit this step if the gear set is to be replaced. If gear set is to be reused, check tooth contact pattern and ring gear backlash before disassembling differential carrier. When checking backlash, a yoke or helical gear must be installed and torqued to get an accurate reading. Best results are obtained when established wear patterns are maintained in used gearing.

1. Mount differential carrier in repair stand.

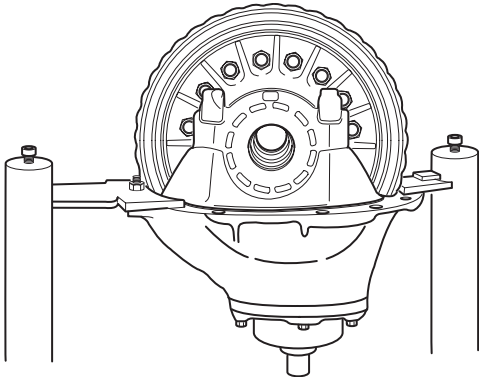

3. Remove cap screws, flat washers and bearing caps. Back off bearing adjusters and remove adjusters and bearing cups.

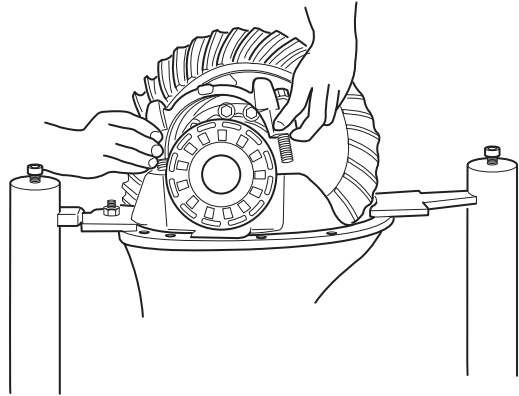

Note: For easier disassembly, loosen but do not remove pinion (self-locking) nut. Forward axle pinion is equipped with slotted nut, remove roll pin with a pin punch then loosen nut.

2. If reusing gear set, also punch mark bearing adjusters for reference during assembly.

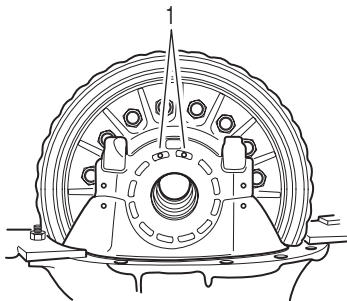

1 - Punch marks

4. Using a chain hoist, lift ring gear and differential assembly out of carrier.

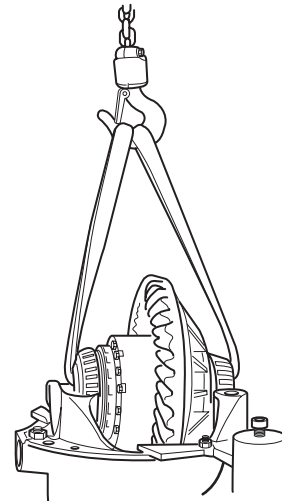

Disassemble, Overhaul and Assemble Wheel Differential

Disassemble Wheel Differential

CAUTION

During following procedure, place differential assembly on malleable surface to prevent damage when ring gear falls off its mounting position.

Procedure -

1. Remove nuts and bolts fastening ring gear to differential cases, allowing gear to fall free. If gear does not fall, tap outer diameter with soft mallet to loosen.

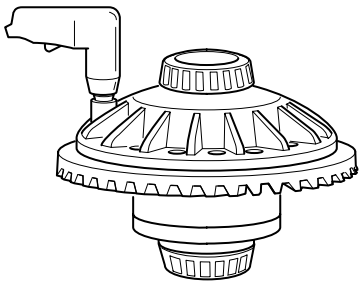

2. Punch mark differential cases for correct location during reassembly. Remove cap screws and lift off plain differential case half.

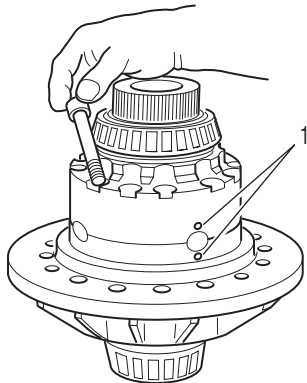

1 - Punch marks

3. Lift out side gear and thrust washer.

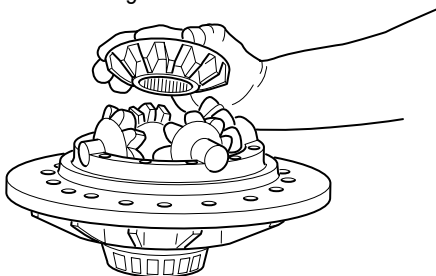

4. Lift out spider, side pinions and thrust washers.

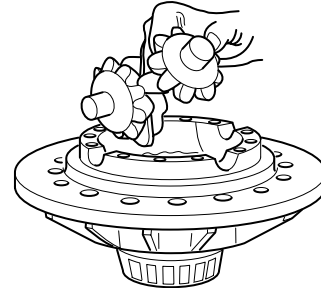

5. Remove remaining side gear and thrust washer.
6. Remove bearing cones from case halves using suitable puller.
7. Remove bearing cone from plain case half in two steps:
 - a. Mount puller vertically to split bearing. This action will start moving bearing off case.

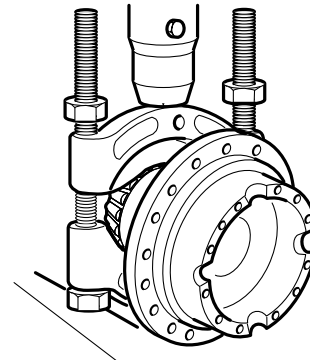

- b. Mount puller horizontally to remove cone.

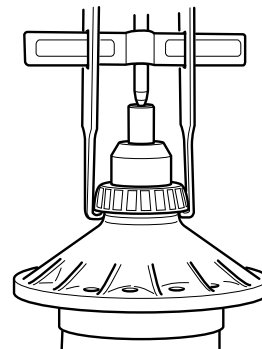

8. Remove bearing cone from flanged case half using suitable puller.

Overhaul and Assemble Wheel Differential

CAUTION

To prevent bearing damage, use suitable sleeve that only contacts the inner race of the cone. A used bearing race would be a suitable tool. This tool should have a slit cut if the ID is the same as the flange OD.

Procedure -

1. Press new flange half bearing cones on differential case halves.

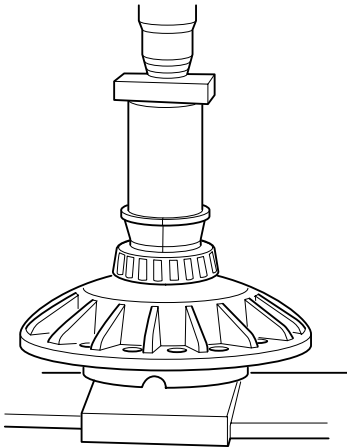

2. Press new plain half bearing cones on differential case halves.

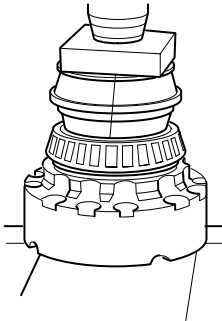

3. Place thrust washer and side gear in flanged differential case.

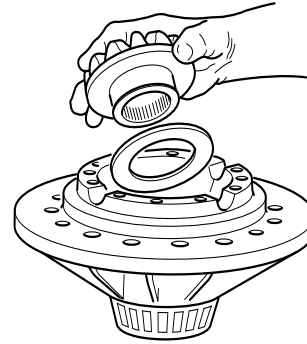

4. Lubricate all differential parts.
5. Assemble side pinion and thrust washers on spider. Place this assembly in flanged differential case. Rotate gears and check for proper mesh.

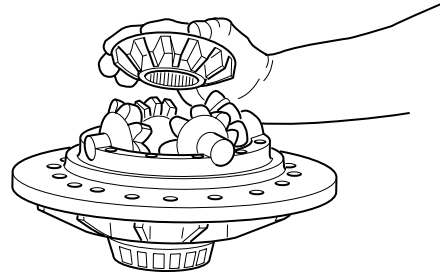

6. Place side gear and thrust washer on side pinions.

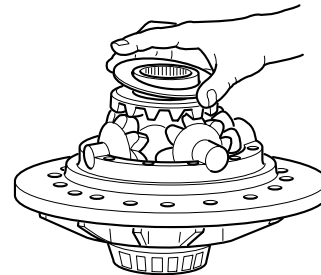

7. Align punch marks and install plain case half. Install cap screws and tighten to proper specifications as outlined in the back of this publication. Check differential for free rotation by turning side gear hub.

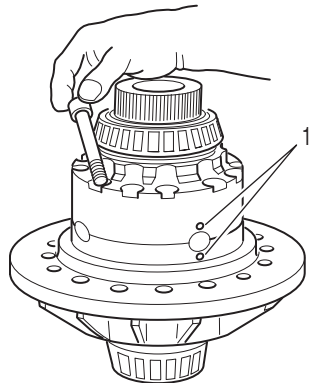

1 - Punch marks

8. Install ring gear. Secure with bolts and nuts.

Note: For 17060, 19060, 21060, 22060 model axles, flange half differential cases were redesigned starting with production axles built in January 1997. New style ring gear bolts are also required with the new style flange case. Torque bolt to proper specifications. listed on page 70.

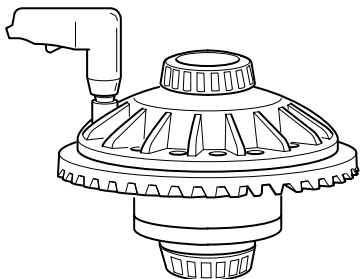

9. Lower assembled differential assembly in to the carrier using a hoist and a strap. Be careful not to damage the differential bearings lowering the assembly.
10. Install the bearing cup and bearing adjuster to the flange half side first.

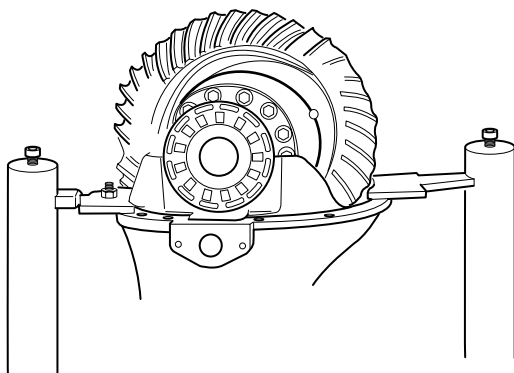

11. Install the bearing cup and bearing adjuster to the plain half side. Use a long screwdriver or bar to lift the differential up while installing the cup and bearing adjuster.

Measure and Adjust Carrier Assembly

Adjust Backlash and Preload

Procedure -

1. Turn the flange half bearing adjuster in until the ring gear contacts the pinion (zero backlash) then back the adjuster out two notches of the adjuster lugs.

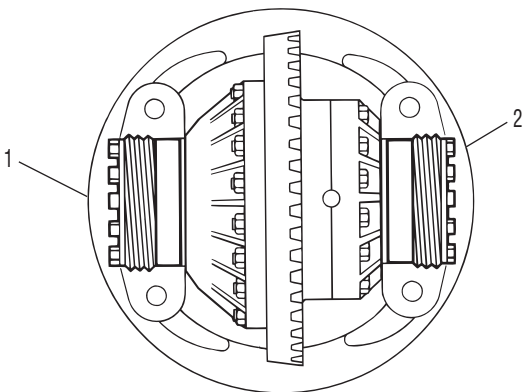

1 - Flange half

2 - Plain half

2. Tighten the plain half adjuster until the bearing cup just starts to turn, this is a zero bearing preload.

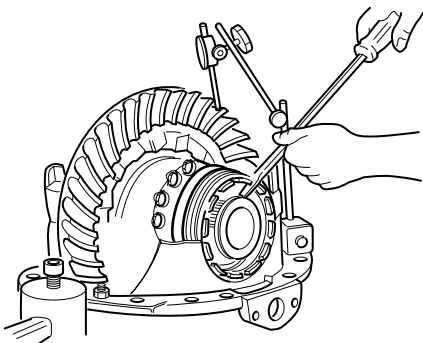

3. Tighten the plain half adjuster two lug notches. Start with the notch at the top, count two notches counterclockwise on the adjuster, and turn the adjuster so the notch is facing straight up. You now have a two notch preload.

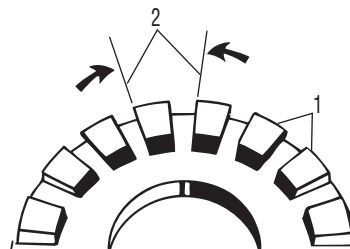

1 - Lugs

2 - One notch

4. Use a rubber mallet to make certain both bearing adjusters are fully seated.
5. Measure backlash. Make sure it is within specification of .008"-.018".

TIP: To give yourself room to adjust contact pattern, set it between .010"-.012".

Change Backlash Setting

If you have too much backlash the ring gear needs to move closer to the pinion. Back off the plain half adjuster, and count the number of notches you backed it off. Each notch equals about .003" of backlash.

▲ IMPORTANT

In order to maintain the differential bearing preload you will need to turn the flange half bearing adjuster the same amount in the same direction. If you need more backlash reverse this procedure.

Procedure -

1. Install carrier bearing caps and torque carrier cap bolts to specifications outlined in the back of this publication.
2. **Recheck Backlash:** If the bearing adjusters were not in straight or fully seated the backlash will change.
 - a. Used Gearing: Reset to backlash recorded before disassembly.
 - b. New Gearing: Backlash should be between .008 and .018".

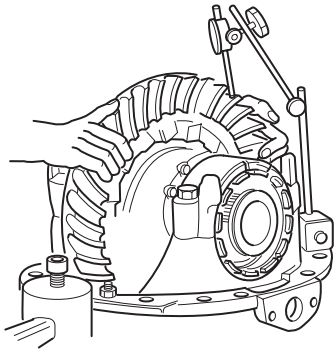

3. Check ring gear tooth contact pattern. Paint ring gear teeth and check tooth contact pattern. Correct tooth patterns. Check adjusting procedures outlined in this section.
4. Install bearing adjuster cotter pins. Measure Ring Gear Runout.

Measure Ring Gear Runout

Procedure -

1. Measure ring gear total radial run out. (Indicator reading should not exceed .010").

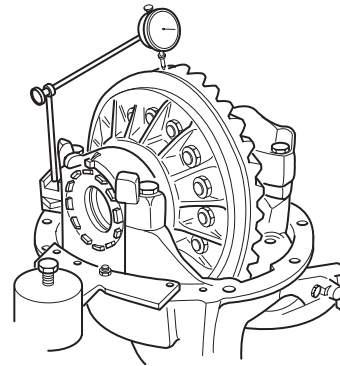

2. Measure ring gear total backface runout. (Indicator reading should not exceed .010").

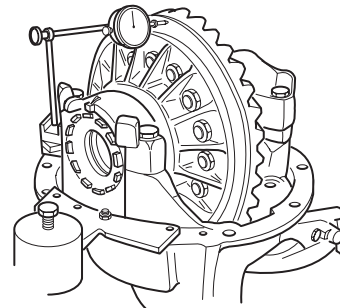

Adjust Ring and Pinion Tooth Contact Pattern

Note: Rear axle gearing is shown in the following instructions. Correct tooth contact patterns and adjustments are the same for forward and rear axles.

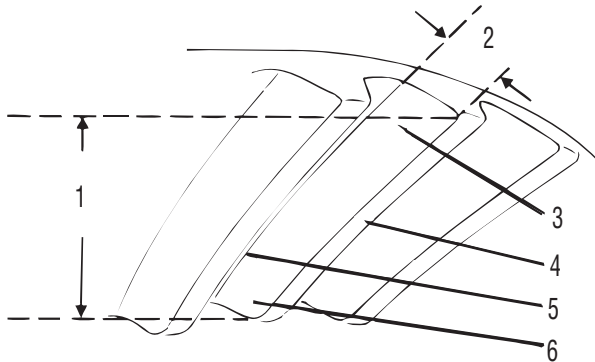

- 1 - Face width
- 2 - Tooth Depth
- 3 - Heel
- 4 - Top land
- 5 - Root
- 6 - Toe

1. Identify if new or used gearing.
2. Check tooth contact pattern (new or used gearing).

New Gearing - Correct Pattern

Paint six ring gear teeth 180° apart with marking compound and roll the gear to obtain a contact pattern. The correct pattern is slightly below center on the ring gear tooth with length-wise contact up off the toe. The length of the pattern in an unloaded condition is approximately one-half to two-thirds of the ring gear tooth in most models and ratios.

The pattern could vary in length and should cover 1/2 tooth or more (face width). The pattern should be evenly centered between tooth top land and root and should be up off the tooth toe.

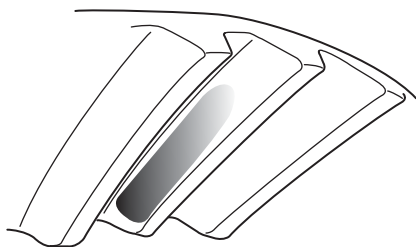

Used Gearing - Correct Pattern

Used gearing will not usually display the square, even contact pattern found in new gear sets. The gear will normally have a "pocket" at the heel end of the gear tooth. The more use a gear has had, the more the line becomes the dominant characteristic of the pattern.

Adjust used gear sets to display the same contact pattern observed before disassembly. A correct pattern is up off the toe and centers evenly along the face width between the top land and root. Otherwise, the length and shape of the pattern are highly variable and is considered acceptable as long as it does not run off the tooth at any point.

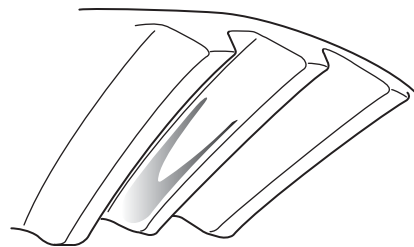

- 1 - Pattern along the face width could be longer

Adjust Contact Pattern

If necessary, adjust the contact pattern by moving the ring gear and drive pinion.

- Ring gear position controls the backlash. This adjustment moves the contact pattern along the face width of the gear tooth.
- Pinion position is determined by the size of the pinion bearing cage shim pack. It controls contact on the tooth depth of the gear tooth.

These adjustments are interrelated. As a result, they must be considered together even though the pattern is altered by two distinct operations. When making adjustments, first adjust the pinion, then the backlash. Continue this sequence until the pattern is satisfactory.

Adjust Pinion Position

If the gear pattern shows incorrect tooth depth contact, change drive pinion position by altering the shim pack. Used gears should achieve proper contact with the same shims removed from the axle at disassembly.

Note: Check ring gear backlash after each shim change and adjust if necessary to maintain the .006" to .018" specifications.

If the pattern is too close to the top land of the gear tooth, remove pinion shims. Move pinion toward the ring gear.

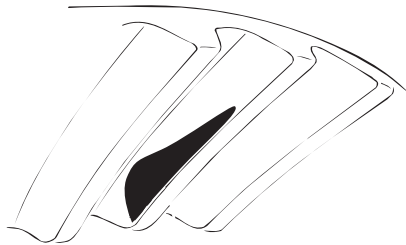

If the pattern is too close to the root of the gear tooth, add pinion shims. Move pinion away from the ring gear.

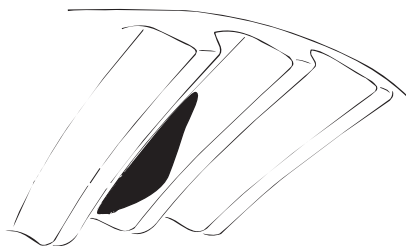

Adjust Ring Gear Position (Backlash)

If the gear pattern shows incorrect face width contact, change backlash by adjusting the ring gear.

If the pattern is too close to the edge of the tooth toe, move the ring gear away from the pinion to increase backlash.

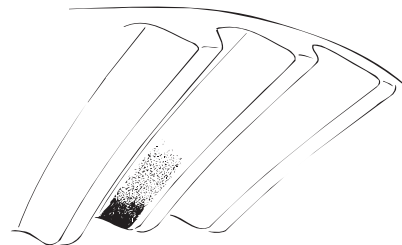

1. Loosen the bearing adjuster on the teeth side of the ring gear several notches.
2. Loosen the opposite adjuster one notch.
3. Return to adjuster on teeth side of ring gear and tighten adjuster until it contacts the bearing cup.
4. Continue tightening the same adjuster 2 or 3 notches and recheck backlash.
 - If the pattern is concentrated at the heel (too far up the tooth), move the ring gear toward the pinion to decrease backlash.

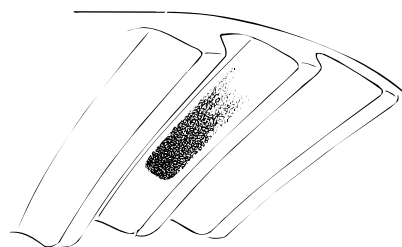

5. Loosen the bearing adjuster on the teeth side of the ring gear several notches.
6. Tighten the opposite adjuster one notch.
7. Return to adjuster on teeth side of ring gear and tighten adjuster until it contacts the bearing cup.
8. Continue tightening the same adjuster 2 or 3 notches and recheck backlash.

Differential Lock Shifting Parts - Exploded View

Type 1

For Models: 19055D, 21065D, 21080D, 21090D, 22065D, 23070D, 23080D, 23085D, 23090D, 23105D, 26080D, 26090D, 26105D, 30105D

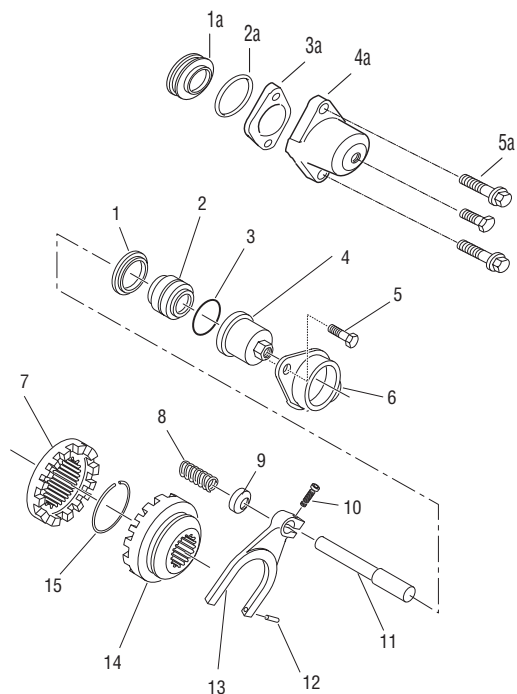

- 1 - Shoulder washer
- 2 - Piston
- 3 - O-ring
- 4 - Shift cylinder body
- 5 - Bracket cap screw
- 6 - Mounting bracket
- 7 - Fixed curvic clutch
- 8 - Compression spring
- 9 - Switch actuator
- 10 - Shift fork cap screw
- 11 - Pushrod
- 12 - Shift fork spring pin
- 13 - Shift fork
- 14 - Sliding curvic clutch
- 15 - Fixed curvic clutch snap ring

- 1a - Piston
- 2a - piston O-ring
- 3a - Shift cylinder gasket
- 4a - Shift cylinder
- 5a - Housing cap screw

Type 2

For models: 17060D, 19060D, 21060D, 22060D

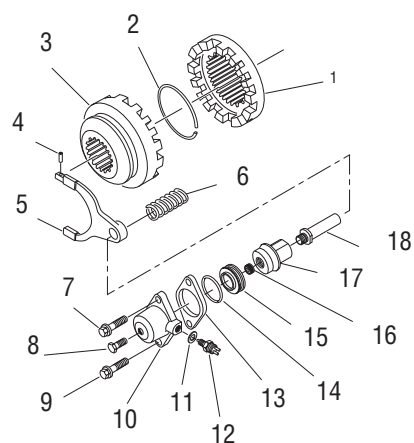

- 1 - Fixed curvic clutch
- 2 - Fixed curvic snap ring
- 3 - Sliding curvic clutch
- 4 - Shift fork spring pin
- 5 - Shift fork
- 6 - Compression spring
- 7 - Cap screw
- 8 - Manual engagement screw
- 9 - Cap screw
- 10 - Piston cover
- 11 - Washer
- 12 - Switch
- 13 - Gasket
- 14 - O-ring
- 15 - Piston
- 16 - Set screw
- 17 - Piston Driver
- 18 - Push rod

Wheel Differential Locking Axles

Comparison Information on Spicer Wheel Differential Locking Axles

This section covers Spicer "Wheel Differential Locking" axles. The basic concept of Dana's Wheel Differential Locking axles are the same, but the designs vary model to model. When servicing your Diff Lock axle, pay close attention to all **NOTES**, **TIPS** and **WARNING** signs that will assist you while you work on your axle. The Diff Lock axles listed below are grouped together by design type. In this section they will be referred to as **Type 1**, or **Type 2**.

Type 1

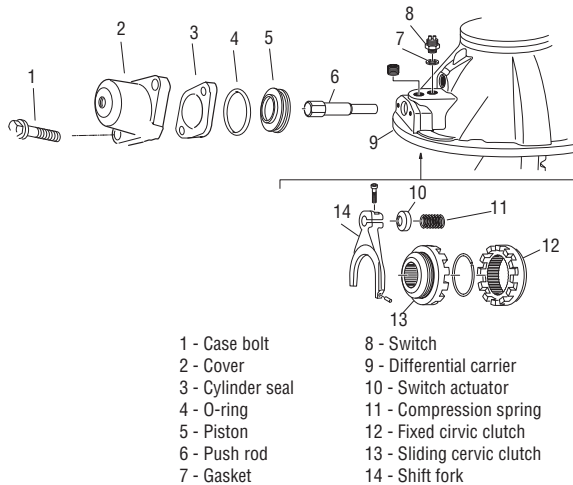

Type 1 Style Diff Lock Axles Feature:

- A sliding curvic clutch
- A fixed curvic clutch
- The **Flange Half Diff Case** is externally splined
- Uses double spline or extended spline axle shaft (11" spline length) on **Flange Half Side** of axle
- Uses standard spline axle shaft (4" spline length) on plain half side of axle
- The Diff Lock selector switch is located on the carrier/ cap assembly

Type 2

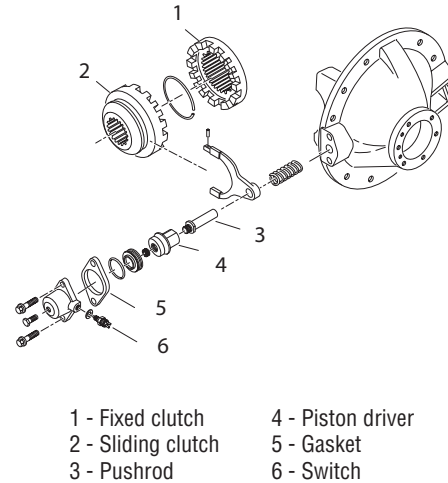

Type 2 Style Diff Lock Axles Feature:

- A sliding curvic clutch
- A fixed curvic clutch
- The **Plain Half Diff Case** is externally splined
- Uses extended spline axle shaft (11" spline length) on plain half side of axle
- Uses standard spline axle shaft (4" spline length) on flange half side of axle
- The Diff Lock selector switch is located on the Diff Lock shift cylinder

Install and Adjust Differential Lock - Type 1 Axles

Special Instructions

Note: With differential carrier completely assembled and adjusted, install differential lock assembly for Type 1 axles as follows:

Procedure -

1. Install fixed curvic clutch on splined hub of flanged differential case.

Type 1

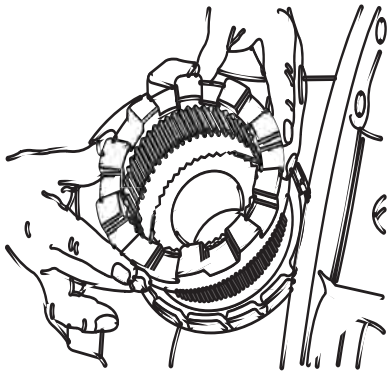

2. Install Snap ring

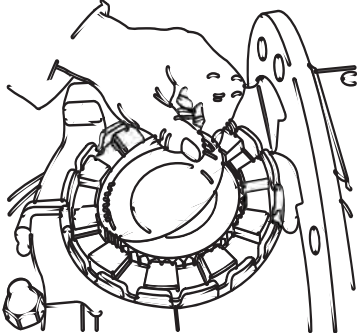

3. If shift fork and sliding curvic clutch are disassembled, engage fork with clutch hub and install spring pin in end of fork long leg to hold components together. See illustration for fork mounting position on clutch. Install clamp screw in fork and tighten finger-tight.

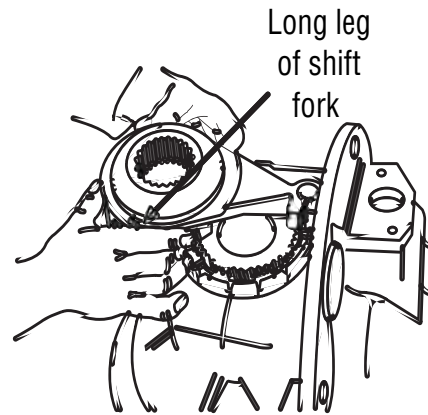

4. Place compression spring and switch actuator in shift box.

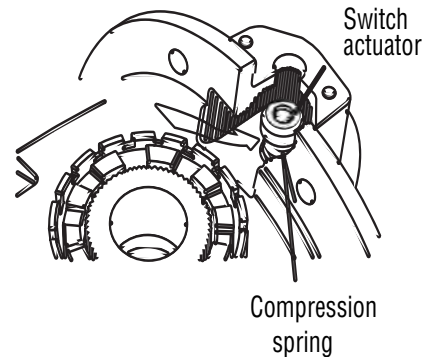

- Position shift fork and clutch assembly on carrier, inserting fork head in shift box on top of actuator. Install pushrod, engaging fork head, switch actuator, compression spring and pilot hole in carrier.

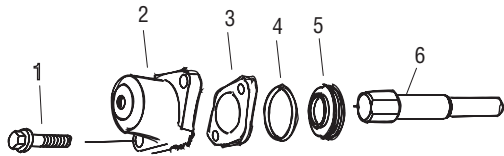

- | | |
|--------------------|--------------|
| 1 - Cover capscrew | 4 - O-ring |
| 2 - Cover | 5 - Piston |
| 3 - Cover gasket | 6 - Push rod |

- Place shift cylinder assembly on end of pushrod. Compress cylinder assembly by hand to keep pushrod piloted in carrier, and install mounting bracket cap screws. Torque to 28-35 lbs.ft. (38-47 N•m).

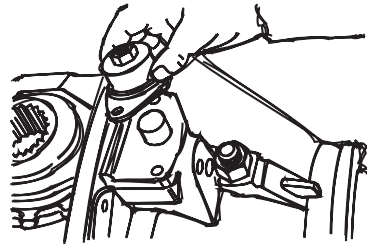

Note: The shift cylinder is serviced only as an assembly. However, if the cylinder is disassembled and parts are serviceable, assemble as described in Steps 5 thru 8.

- Install new O-ring on piston.

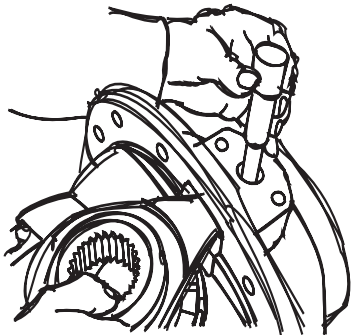

Note: At this stage of assembly, adjust shift fork position.

- Lubricate piston and O-ring with silicone grease and install piston with small diameter hub toward closed end of cylinder.
- Install seal on cylinder, piloting seal shoulder inside cylinder.
- Install mounting bracket on cylinder.

Shift Fork Adjustment - Type 1 Axles

Procedure -

1. With clutches disengaged, adjust position of shift fork on pushrod to set a clearance of .120" (3.05mm) between the clutch teeth.
2. **Adjust as follows:** Place two .120" (3.05mm) feeler gauges (one on each side of the clutches) between the tips of the clutch teeth. Slide shift fork on pushrod to set clutch clearance. Working through carrier pipe plug opening, tighten shift fork cap screw to 12-15 lbs.ft. (16-20 N•m) torque.

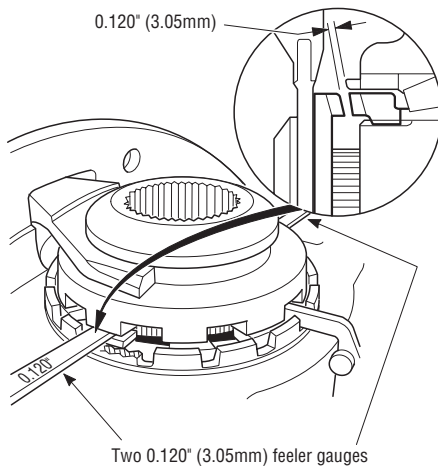

3. Check differential lock clutch engagement by one of the following methods:

Air Pressure Engagement: Apply air pressure (80-120 psi) to shift cylinder port to engage clutches.

Manual Engagement: Install an M12x1.5 bolt, over 38mm (1.5") long, in the cylinder air port to manually engage clutches.

Note: Hand-tighten the bolt. Over-torquing may cause damage to the shift unit. To facilitate hand-tightening, lubricate bolt threads with axle lube.

4. **Correct Fork Adjustment:** Fork adjustment is correct when clutch curvic teeth are fully engaged with the fork free when moved by hand (see illustration). When air pressure is released or manual bolt is removed, the shift assembly should disengage freely.

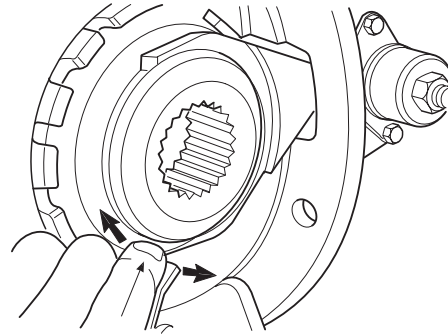

5. Recheck the .120" (3.05mm) clutch teeth clearance with shift cylinder fully disengaged. If not correct, readjust fork position (see Steps 1 and 2).
6. With differential lock correctly adjusted, coat pipe plug with sealant and install plug in carrier shift box.
7. Install selector switch and plastic washer in carrier shift box. Torque switch to 10-12 lbs.ft. (14-16 N•m).
8. **Check Selector Switch Operation:** Check switch electrically with an ohmmeter or continuity tester. Switch should close (show continuity) when clutches are engaged and should open (no continuity) when clutches are disengaged.

Install and Adjust Differential Lock - Type 2 Axles

Note: With differential carrier completely assembled and adjusted, install differential lock as follows:

Procedure -

1. Install fixed curvic clutch on splined hub of flanged differential case, then install snap ring.
2. If shift fork and sliding curvic clutch are disassembled, engage fork with clutch hub, and install spring pin in the long leg of the fork. See illustration for fork mounting position on clutch.
3. Position compression spring, shift fork and clutch assembly in shift opening of the carrier. Align pilot hole of shift fork with pilot hole of carrier. Install pushrod, engaging shift fork head and compression spring in carrier.

Note: The shift cylinder is serviced only as an assembly. However, if the cylinder is disassembled and parts are serviceable, assemble as described in Steps 4 and 5.

4. Install new O-ring on piston.
5. Lubricate piston and O-ring with silicone grease and install piston assembly in cylinder. Position piston with small diameter hub toward closed end of cylinder.
6. Screw piston driver on pushrod.
7. Tighten piston driver until shift fork clutch is approximately .030 of an inch from the fixed clutch.
8. Push down by hand on the piston driver, both clutches must be completely engaged.
9. Install set screw in piston driver and torque to 12-15 lbs.ft. (16-20 N•m).
10. Trial fit, install piston cover assembly. Hand tighten cap screws.
11. Screw in manual engagement screw by hand approximately 1 inch or until snug fit (light resistance pressure is felt). Both clutches must be completely engaged.
12. Remove manual engagement screw clutches until completely disengaged.
 - Repeat above procedure if clutches are not completely disengaged.

Note: Fork adjustment is correct when curvic clutch teeth are fully engaged with the fork free when moved by hand. When air pressure is released or the manual bolt is removed, the shift assembly should disengage freely.

13. When adjustment is complete, torque fasteners to 28-35 lbs.ft. (38-47 N•m).

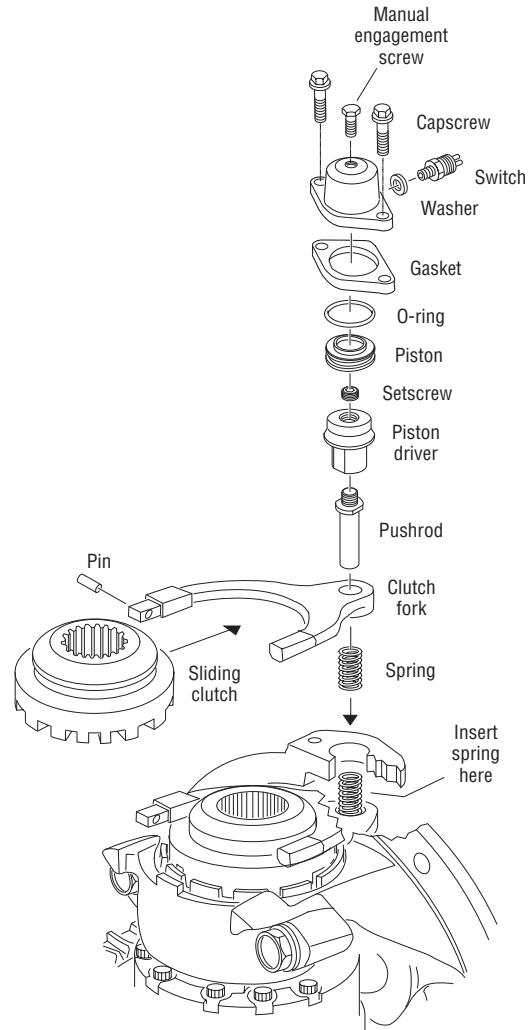

Install and Adjust Differential Lock - Type 2 Axles Continued

Procedure -

1. Install selector switch in cylinder cover. Torque switch to 10-12 lbs.ft (14-16 N•m).

Note: Effective July 1, 1996, Dana will standardize on the selector switch and wiring harness. Reference Bulletin ABIB-9609. Types 1 and 2 switches with 12 mm threads will be discontinued. The selector switch and wiring harnesses are interchangeable with each other.

Check Selector Switch Operation: Check switch electrically with an ohmmeter or continuity tester. Switch should close (show continuity) when clutches are engaged and should open (no continuity) when clutches are disengaged

Install Differential Carrier Assembly in Axle Housing: The differential lock must be engaged and held in the engaged position for installation of carrier assembly in axle housing. This can be accomplished by one of the following two methods:

Air Pressure Engagement: Using an auxiliary air line, apply 80-120 psi air pressure to shift cylinder air port to engage clutch.

Manual Engagement: Install an M12x1.5 bolt, over 38mm (1.5") long, in the cylinder air port to manually engage the clutches

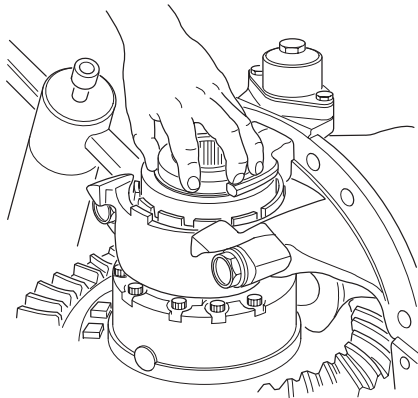

With clutches engaged, grasp fork long leg between thumb and forefinger. Move fork back and forth to check for free movement.

Some GM models use a .250 x 18 NPSM (128642), manual engagement bolt.

Note: Hand-tighten the bolt, over-torquing may cause damage to the shift unit. To facilitate hand tightening, lubricate bolt threads with axle lube.

2. Complete the installation of the carrier following instructions for your specific axle.

CAUTION

When installing axle shafts, make sure the long/splined shaft is installed in the shift unit side of differential carrier

3. After carrier and axle shaft installation, disconnect auxiliary air line or remove bolt from cylinder air port. Connect vehicle air supply to shift cylinder and electrical lead wires to selector switch
4. Check differential lock operation from driver's cab before releasing vehicle for service.
5. Verify the driver caution label is in the vehicle cab and is easily visible by the driver.

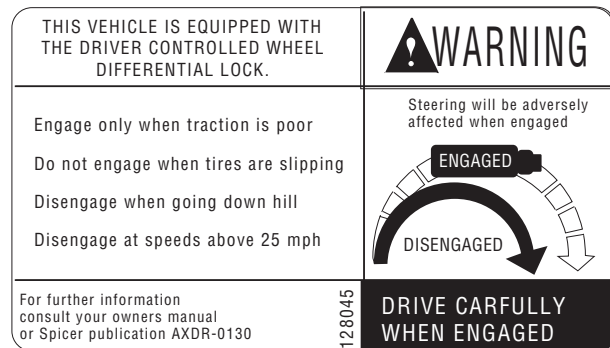

Warning Label 128045

Install and Adjust Wheel Differential Lock

Note: With differential carrier completely assembled and adjusted, install differential lock as follows:

Procedure -

1. Install fixed curvic clutch on splined hub of flanged differential case, then install snap ring.
2. If shift fork and sliding curvic clutch are disassembled, engage fork with clutch hub and install spring pin in the long leg of the fork. See illustration for fork mounting position on clutch.
3. Position compression spring, shift fork and clutch assembly in shift opening of the carrier. Align pilot hole of shift fork with pilot hole of carrier. Install pushrod, engaging shift fork head, and compression spring in carrier.
4. Install new O-ring on piston.
5. Lubricate piston and O-ring with silicone grease and install piston assembly in cylinder. Position piston with small diameter hub toward closed end of cylinder.
6. Screw piston driver on pushrod.
7. Tighten piston driver until shift fork clutch is approximately .030" from the fixed clutch.

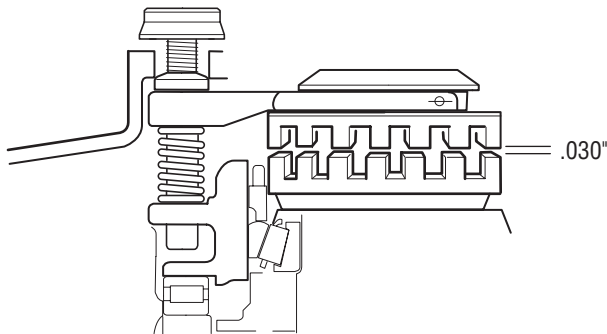

8. Push down by hand on the piston drive. Both clutches must be completely engaged.
9. Install set screw in piston driver, and torque to 12–15 ft.lbs. (16–20 N•m).
10. Trial fit, install piston cover assembly. Hand tighten cap screws.
11. Screw in manual engagement screw, by hand approximately 1 inch or until snug fit (light resistance pressure is felt) both clutches must be completely engaged.

12. Remove manual engagement screw, clutches must be completely disengaged.
13. Repeat above procedure if clutches not completely disengaged.

Note: Fork adjustment is correct when curvic clutch teeth are fully engaged with the fork free when moved by hand. When air pressure is released or the manual bolt is removed, the shift assembly should disengage freely.

14. When adjustment is complete, torque fasteners to 28–35 ft.lbs. (38–47 N•m).
15. Install selector switch in cylinder cover. Torque switch to 10–12 ft.lbs. (14–16 N•m).
16. **Check selector switch operation:** Check switch electrically with an ohmmeter or continuity tester. Switch should close (show continuity) when clutches are engaged and should open (no continuity) when clutches are disengaged.

Install and Adjust Ring Gear Thrust Bolt Procedure -

1. Thread thrust screw into the carrier until firm contact with the back face of the ring gear is made.
2. Loosen the thrust screw 1/4 turn to obtain the correct adjustment of .020" (.50mm) clearance between gear face and screw. Tighten jam nut, holding thrust screw stationary with a wrench, torque jam nut 150–190 ft. lbs. (203–258 N•m).
3. Recheck to assure minimum clearance during full rotation of ring gear.

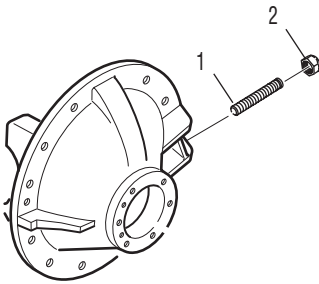

- 1 - Rear carrier or front carrier
- 2 - Thrust bolt
- 3 - Thrust bolt jam nut

Install New Axle Housing Breather - (Metal and Plastic)

Spicer uses an axle housing breather that consists of a fitting, hose, and clamp assembly. This breather design has improved resistance to water ingestion, and clogging caused by dirt, ice or snow buildup around the base of the breather. See installation instructions below (all views from rear).

Plastic only: Tighten until one thread is showing.

Procedure -

1. Install fitting in breather hole.

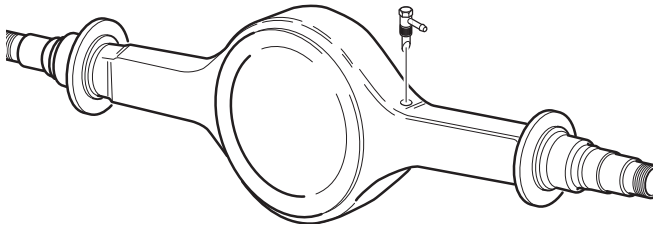

2. Tighten fitting finger tight.

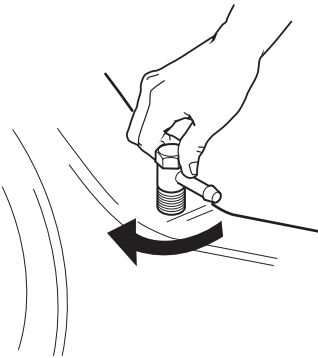

3. Using a 3/4" wrench:

Metal only: Rotate the fitting at least 1/2 turn until nipple points to rear.

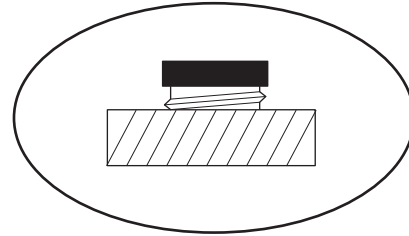
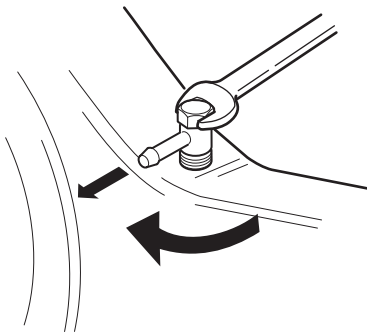

4. Insert hose onto fitting, long end down.

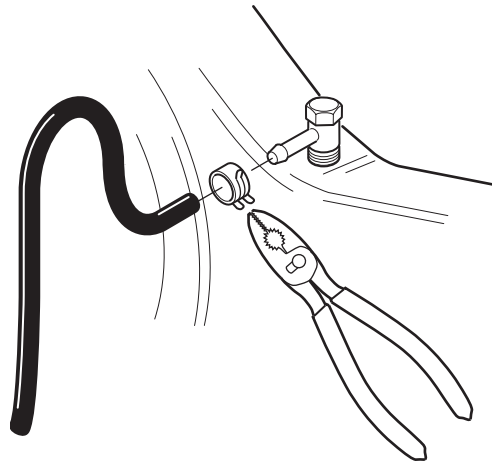

5. Push hose firmly against fitting. Rotate hose to point down.

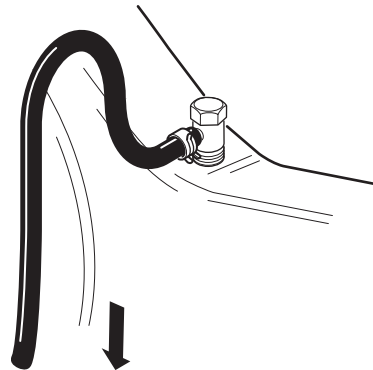

Axle Housing - Exploded View

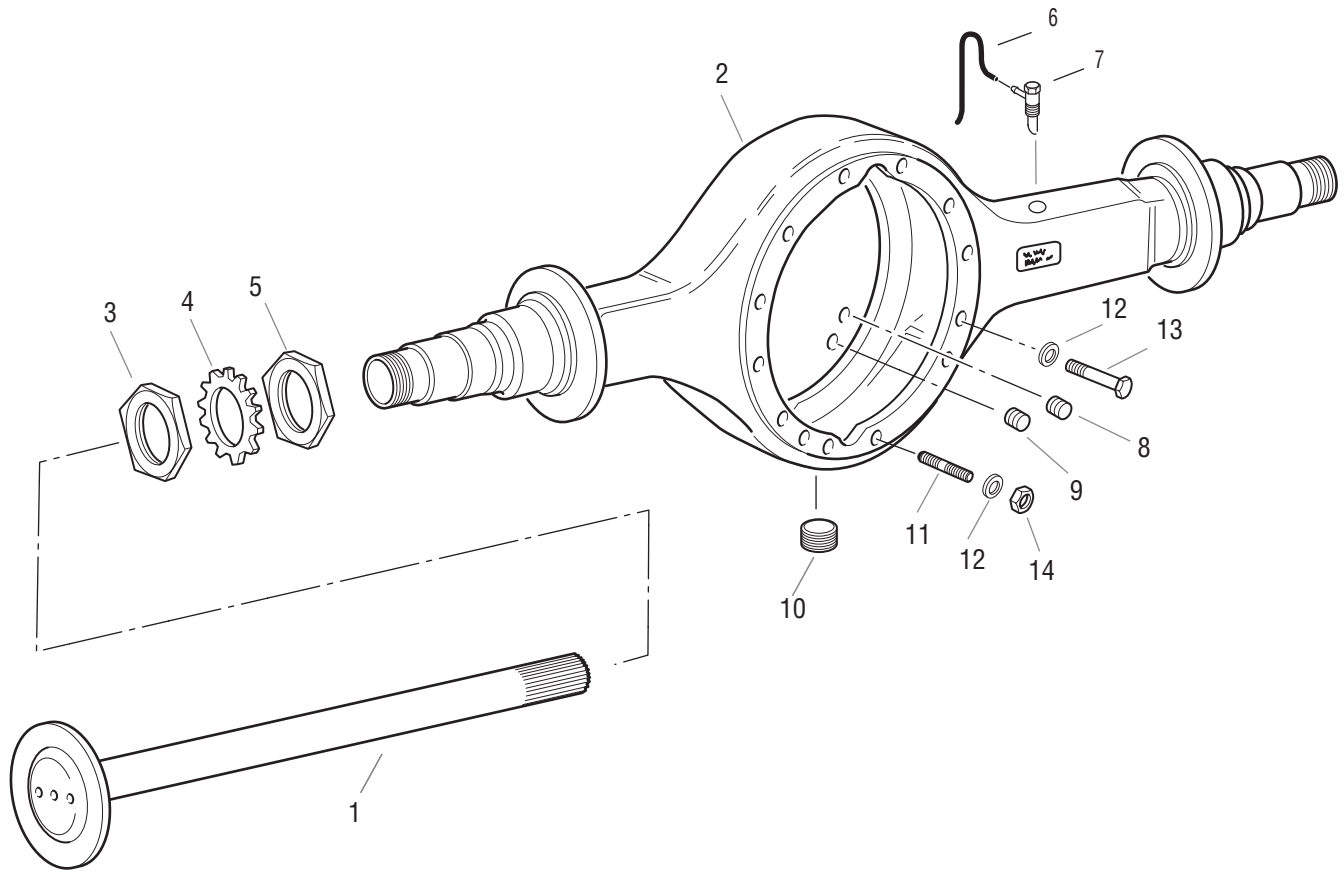

61510-8-95

- 1 - Axle Shaft
- 2 - Axle Housing Assembly
- 3 - Outer Nut
- 4 - Lock Washer
- 5 - Inner Nut
- 6 - Housing Breather Tube
- 7 - Housing Fitting
- 8 - Fill Plug
- 9 - Oil Sensor Plug
- 10 - Drain Plug
- 11 - Housing Stud
- 12 - Hardened Washer
- 13 - Carrier Capscrew
- 14 - Nut, Stud

Inter-Axle Speed Sensor Parts - Exploded View

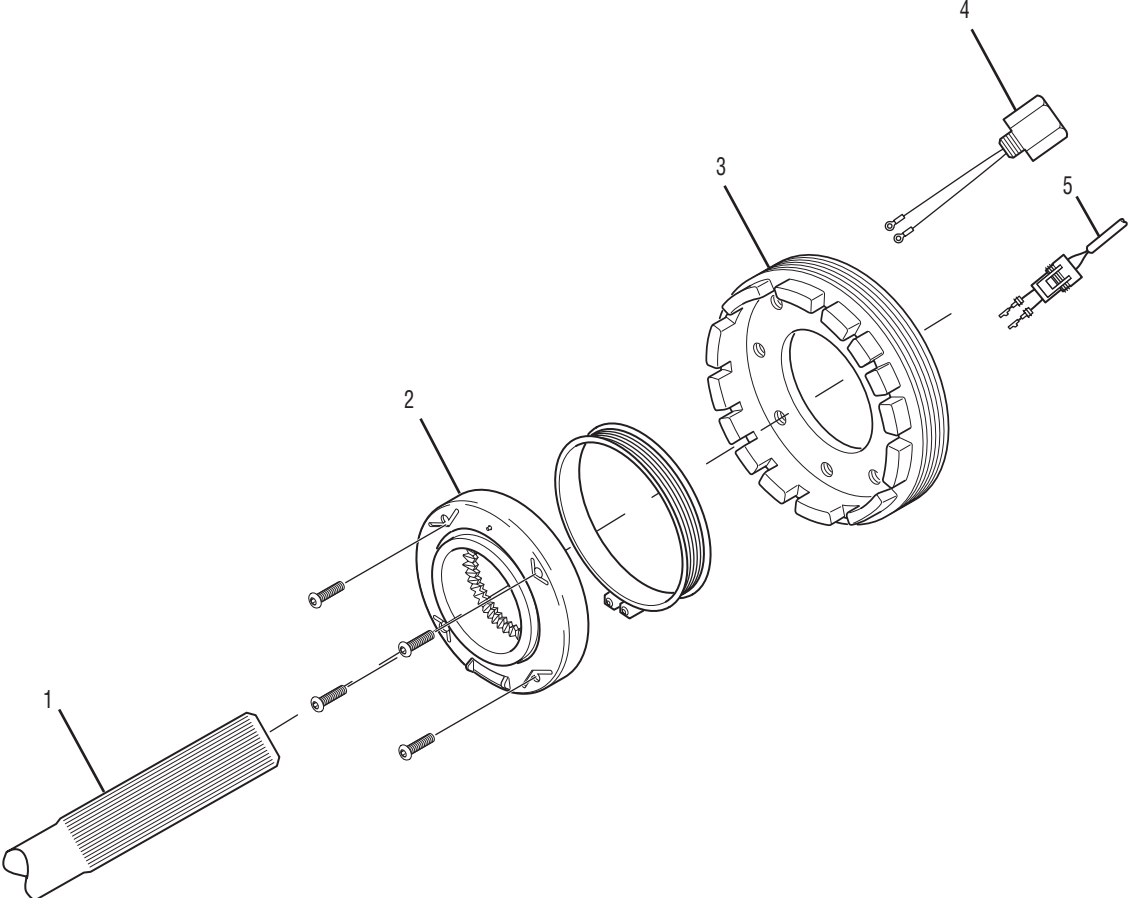

- 1 - Axle shaft
- 2 - Speed sensor
- 3 - Differential bearing adjuster
- 4 - Plated connector
- 5 - ABS Harness connector

Disassemble and Overhaul Inter-Axle Speed Sensor

Disassemble

The design of the drive axle sensor allows replacement of several individual components without disassembling the complete sensor system. For example:

- The differential bearing adjuster does not need to be removed in order to replace any other component.
- The sensor and rotor can be replaced without removing or replacing the plated connector.

At every stage of drive axle service, try to isolate the problem to specific components in order to avoid unnecessary disassembly.

Procedure -

1. Disconnect two wires from sensor terminals.
2. Carefully inspect wires and connector. If connector is intact and if there is no prior indication that connectors and wires require replacement, do not unscrew plated connector. The sensor may be replaced without replacing connector and wire.
3. Remove four screws from face of sensor.
4. Remove sensor from differential bearing adjuster.

Overhaul

Note: If plated connector was damaged during axle disassembly or if there is indication of a wiring fault, the connector assembly must be replaced.

There are two different connectors with two different lengths of terminal wires. See Inter-Axle Speed Sensor Service Manual AXSM-0034.

If sensor assembly is to be replaced, install new sensor before finishing installation of new connector. The final position of the sensor terminals must be fixed before wires can be sealed in place.

To install new connector:

1. Clean threaded hole in carrier and wire path to allow proper seal for new connector. (Male threads on the new connector have microencapsulated Loctite).
2. Insert connector and torque to 20–28 lbs.ft. (27–38 N•m).
3. Route wires to the sensor location.

Install Inter-Axle Speed Sensor

Except for routing the wires between the sensor and the plated connector, procedures for installing both drive axle speed sensors are identical. The instructions which follow cover the long arm (plain half) side speed sensor and require careful routing of the 6 inch long connector wires to prevent pinching between the head and housing.

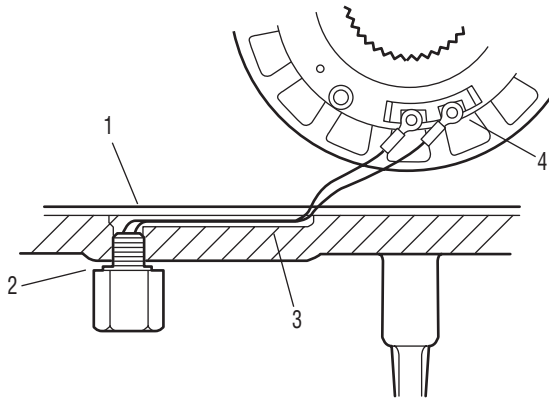

- 1 - Wires seated in channel
- 2 - Connector hole is on carrier mounting surface
- 3 - 6 inch long wires
- 4 - Sensor terminals positioned near carrier mounting surface

Procedure -

1. Lubricate interior rotor with axle lube or grease. Check that the rotor turns freely by hand.
2. Mate the rotor and the sensor assembly.
3. Align the sensor/rotor assembly with the face of the adjuster so the terminals are nearest the carrier mounting surface.
4. Orient the sensor to line up the holes in the sensor with the threaded holes in the adjuster. Rotate the sensor in either direction to get the fit that keeps the terminals near the carrier mounting surface. This final adjustment should only require a slight shift in sensor position.
5. Apply Loctite to the four mounting screws. Install the screws and tighten in a "star" pattern to maintain sensor alignment. Torque to 28–32 in.lbs. (3.2–3.6 N•m). (A preferred tightening approach is the "turn of bolt" method: torque screws finger tight then tighten additional 1/4 turn).

6. Attach the two round terminals to sensor. Either wire can connect to either sensor blade. Make sure terminals are not bridged and connectors are not touching. Torque to 10–15 in.lbs. (1.1–1.7 N•m).
7. Before sealing wires in place, check sensor continuity by measuring the resistance between pins on the outside of the connector. Resistance between connector pins should be 1125 to 1375 ohms.
8. Check wire routing. Make sure wire is seated in the cast-in channel and will not get pinched when the head is reassembled to the housing. Seal wire in place with RTV.
9. To replace sensor on the short arm (flanged half) side, repeat previous steps. Since connector location is inside the mounting surface, there is less concern for pinching of the shorter 4 inch connector wires. However, before final assembly, check wire position and routing to make sure it is not crimped or pinched.

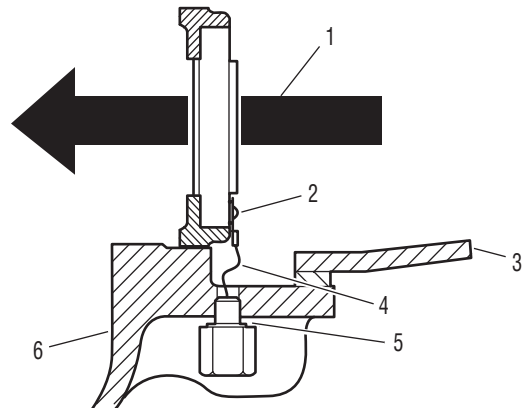

- 1 - Installed position of axle shaft
- 2 - Sensor terminals positioned near connector hole
- 3 - Axle housing
- 4 - 4 inch long wires
- 5 - Connector hole is not on carrier mounting surface
- 6 - Axle carrier

Wheel End Seal Parts - Exploded View

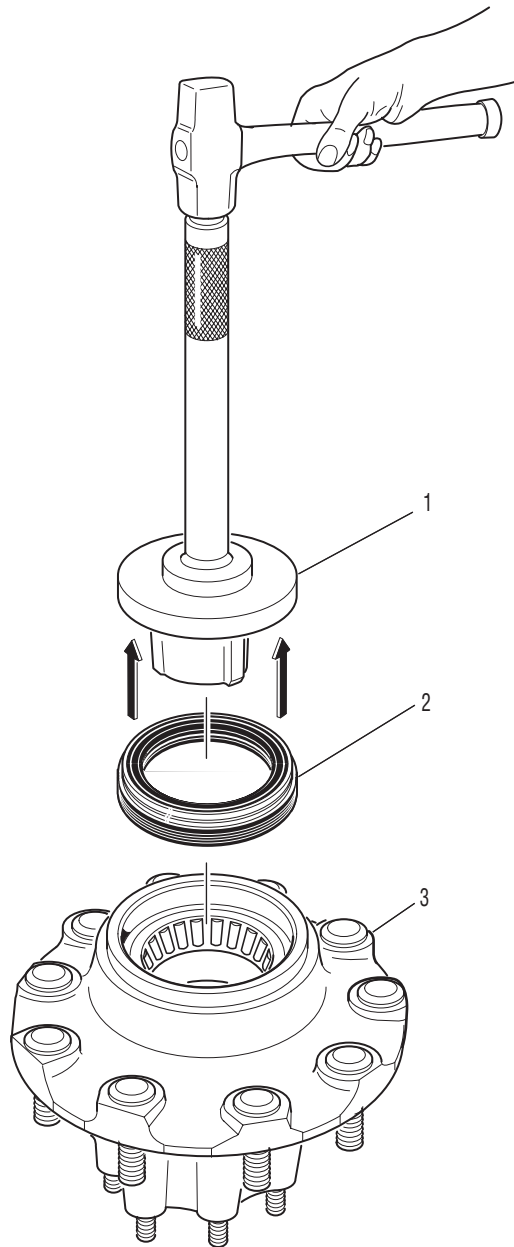

- 1 - Installation tool
- 2 - Seal
- 3 - Rear hub

Remove and Overhaul Wheel End Seal

⚠ WARNING

Never work under a vehicle supported by only a jack. Always support vehicle with stands. Block the wheels and make sure the vehicle will not roll before releasing the brakes.

⚠ CAUTION

Wheel end seals can be easily damaged during handling. Leave the seal in its package until installation to prevent damage or contamination.

Procedure -

1. Remove outer bearing and wheel.
2. Remove oil seal.
3. Remove inner bearing.
4. Remove old wear sleeve (2-piece design only) with a ball peen hammer and discard.

⚠ CAUTION

Do not cut through the old wear sleeve. Damage to the housing may result.

Note: Deep gouges can be repaired by filling gouge with hardening gasket cement and smoothing with emery cloth.

5. Inspect spindle journal and hub bore for scratches or burrs. Recondition with an emery cloth as required.
6. Clean hub cavity and bearing bores before reassembly. Be sure to remove contaminants from all recesses and corners.
7. Clean bearings thoroughly with solvent and examine for damage. Replace damaged or worn bearings.

⚠ CAUTION

Always use the seal installation tool specified by the seal manufacturer. Using an improper tool can distort or damage the seal and cause premature seal failure.

Install Wheel End Seal

Procedure -

1. Before installation, lubricate the following with the same lubricant used in the axle sump.
 - Inner bearing
 - Wheel seal (follow the directions provided by the seal supplier)
2. Place seal on installation tool.
3. Drive seal with installation tool onto hub.

Adjust Wheel Bearing

WARNING

Do not mix spindle nuts and lock washers from different systems. Mixing spindle nuts and lock washers can cause wheel separation

Note: The lock washer for a four-piece tang/dowel-type wheel nut system is thinner than the lock washer for a three-piece tang-type wheel nut system and is not designed to bear against the inner nut.

Procedure -

1. Inspect the spindle and nut threads for corrosion and clean thoroughly or replace as required.

Note: Proper assembly and adjustment is not possible if the spindle or nut threads are corroded.

2. Inspect the tang-type washer (if used). Replace the washer if the tangs are broken, cracked, or damaged.
3. Install the hub and drum on the spindle with care to prevent damage or distortion to the wheel seal.

CAUTION

A wheel dolly is recommended during installation to make sure that the wheel seal is not damaged by the weight of the hub and drum. Never support the hub on the spindle with just the inner bearing and seal. This can damage the seal and cause premature failure.

4. Completely fill the hub cavity between the inner and outer bearing races with the same lubricant used in the axle sump.
5. Before installation, lubricate the outer bearing with the same lubricant used in the axle sump.

Note: Lubricate only with clean axle lubricant of the same type used in the axle sump. Do not pack the bearings with grease before installation. Grease will prevent the proper circulation of axle lubricant and may cause wheel seal failure.

6. Install the outer bearing on the spindle.
7. Install the inner nut on the spindle. Tighten the inner nut to 200 ft.lbs. (271 N•m) while rotating the wheel hub.

CAUTION

Never use an impact wrench to adjust wheel bearings. A torque wrench is required to assure the nuts are properly tightened

8. Back off the inner nut one full turn. Rotate the wheel hub.
9. Retighten the inner nut to 50 ft. lbs. (68 N•m) while rotating the wheel hub.
10. Back off the inner nut exactly 1/4 turn.

Note: This adjustment procedure allows the wheel to rotate freely with 0.001" - .005" (0.025 mm–0.127 mm) end-play.

11. Install the correct lock washer for the wheel nut system being used.

Three-piece Dowel-type Lock Washer System

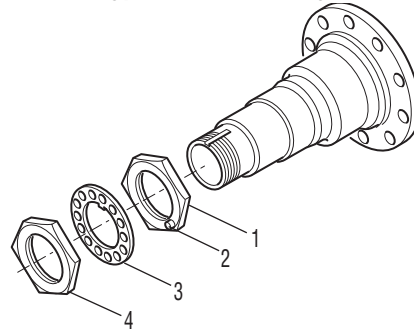

- 1 - Inner nut
- 2 - Dowel pin
- 3 - Dowel-type lock washer
- 4 - Outer nut

- a. Install the Dowel-type lock washer on the spindle.

Note: If the dowel pin and washer are not aligned, remove washer, turn it over and reinstall. If required, loosen the inner nut just enough for alignment.

Note: Never tighten the inner nut for alignment. This can preload the bearing and cause premature failure.

- b. Install the outer nut on the spindle and tighten to 350 ft.lbs. (475 N•m).
- c. Verify end-play, see "Verify Wheel End Play Procedure".

Three-piece Tang-type Lock Washer System

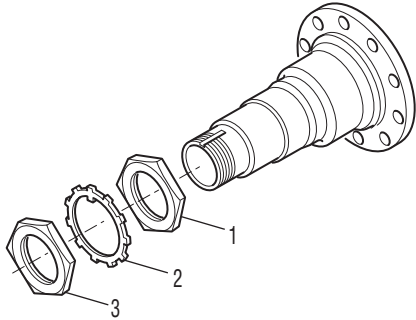

- 1 - Inner nut
- 2 - Tang-type lock washer .123" thick
- 3 - Outer nut

- a. Install the Tang-type lock washer on the spindle.

Note: Never tighten the inner nut for alignment. This can preload the bearing and cause premature failure.

- b. Install the outer nut on the spindle and tighten to 250 ft.lbs. (339 N•m).
- c. Verify end-play, see "Verify Wheel End Play Procedure".
- d. After verifying end-play, secure wheel nuts by bending one of the locking washer tangs over the outer wheel nut and another tang over the inner wheel nut.
- e. Go to step 12.

Four-piece Tang/Dowel-type Lock Washer System

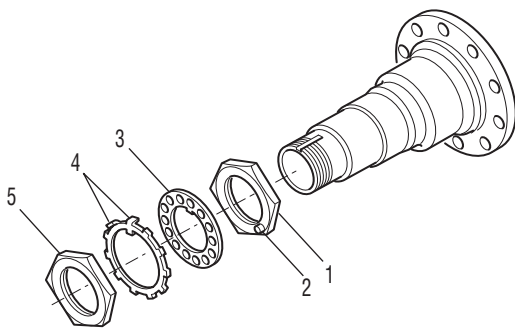

- 1 - Inner nut
- 2 - Dowel pin
- 3 - Dowel-type lock washer
- 4 - Tang-type lock washer .0478" thick
- 5 - Outer nut

- a. Install the Dowel-type lock washer on the spindle.

Note: If the dowel pin and washer are not aligned, remove washer, turn it over and reinstall. If required, loosen the inner nut just enough for alignment.

Note: Never tighten the inner nut for alignment. This can preload the bearing and cause premature failure.

- b. Install the Tang-type lock washer on the spindle.
 - c. Install the outer nut on the spindle and tighten to 250 ft.lbs. (339 N•m).
 - d. Verify end-play, see "Verify Wheel End Play Procedure".
 - e. After verifying end-play, secure the outer nut by bending (180° apart) two opposing tangs of the locking washer over the outer nut.
12. Install the following:
 - New gasket at axle shaft flange.
 - Axle shaft.
 - Axle flange nuts and tighten to specified torque.
 13. Lubricate axle wheel ends.

Verify Wheel End-Play Procedure

Verify end-play meets specification using a dial indicator. An indicator with .001" (.03 mm) resolution is required. Wheel end play is the free movement of the tire and wheel assembly along the spindle axis.

Correct end-play is .001"-.005" (.025-.125 mm).

Adjust End-Play with Tire and Wheel Assembly

Procedure -

1. Attach a dial indicator with its magnetic base to the hub or brake drum.

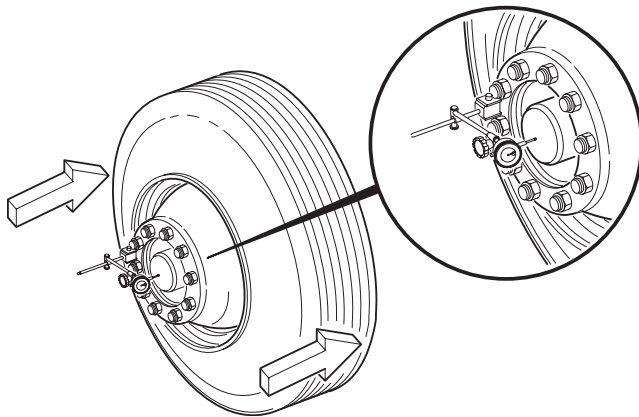

2. Adjust the dial indicator so its plunger or pointer is against the end of the spindle with its line of action approximately parallel to the axis of the spindle.
3. Grasp the wheel assembly at the 3 o'clock and 9 o'clock positions. Push the wheel assembly in and out while oscillating it to seat the bearings. Read bearing end-play as the total indicator movement.

CAUTION

If end-play is not within specification, readjustment is required.

Adjust End-play with Wheel Hub

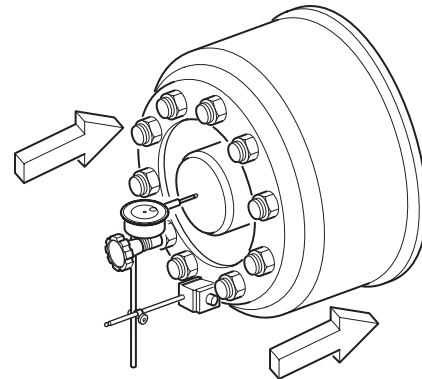

Insufficient End-play--If end-play is not present, remove the outer nut and pull the lock washer away from the inner nut, but not off the spindle. Loosen the inner nut to the next adjustment hole of the dowel-type washer (if used). Reassemble the washer and re-torque the outer nut. Verify end-play with a dial indicator.

Excessive End-play--If end-play is greater than .005" (.127 mm), remove the outer nut and pull the lock washer away from the inner nut, but not off the spindle. Tighten the inner nut to the next alignment hole of the dowel-type washer (if used). Reassemble the washer and re-torque the outer nut. Verify end-play with a dial indicator.

Fine Tuning the End-play--If, after performing the readjustment procedures, end-play is still not within the .001"- .005" (.025-.127 mm) range, disassemble and inspect the components. If parts are found to be defective, replace the defective parts, reassemble and repeat wheel bearing adjustment procedure. Verify end-play with a dial indicator.

Lubrication Information

Note: For Lubrication information see TCMT 0021 Lubrication Manual

Proper Vehicle Towing

Towing of Axles Equipped with Wheel Differential Lock

1. Engage the wheel differential lock until the indicator light is on (move vehicle to verify engagement).
2. Shift transmission into neutral.
3. With vehicle stationary, release the air pressure on the wheel differential. lock shift system and apply the parking brake.
4. Disconnect the air supply and fitting at the shift cylinder.
5. Install the shipping cap screw or 128274 (M12 X 1.5 screw) or 128642 (.250 X 18 NPSM screw). Manually engage the wheel diff. lock until the indicator light is on and the main differential lock is completely engaged.
6. Remove the axle shafts.

Note: Axle shafts are location specific. Remember the double-splined or extended splined axle shafts are located on the “shift cylinder” side of the axle.

7. Install temporary cover on hub to prevent contamination entering and also to prevent the loss of lubricant.

Description

The Spicer Wheel Differential Lock is an optional feature for Spicer Axles. In operation, it positively locks the wheel differential to provide improved traction under adverse road conditions.

The differential lock is driver-controlled through an electric switch or air valve mounted in the cab. The locking mechanism is air-operated to engage a mechanical clutch and lock the wheel differential. It is spring-operated to disengage the lock and permit the wheel differential to function normally.

The Wheel Differential Lock consists of three major assemblies .

- A shift cylinder assembly which operates a shift fork and push rod assembly.
- A shift fork and push rod assembly which engages and disengages the differential lock curvic clutch assembly.
- A curvic clutch assembly which consists of a sliding clutch splined to a axle shaft and a fixed clutch which is splined to the differential case hub.

The Differential Lock also includes a selector switch (electric) which senses clutch engagement and sends an electrical signal to a cab mounted indicator light (or an audible signal device).

Without Wheel Differential Lock

Lift the drive wheels completely off of the ground or damage will occur.

⚠ WARNING

Do not lift the front wheels (non-drive wheels). This alters the oil's position in the drive axle, draining it away from the drive pinion and its bearings. If the pinion is rotated under these conditions for any period of time, bearings will over-heat resulting in axle damage or failure

If this is impossible to lift the drive wheels, remove all axle shafts to prevent gear rotation and cap the wheel hubs to prevent loss of lubricant and a possible road hazard. See the previous section “Proper Vehicle Towing with Wheel Differential Lock” for removal procedure.

Operate Wheel Differential Assembly

The Spicer Wheel Differential Lock is driver-controlled and operated by a carrier mounted air-actuated shift unit. In operation, it positively locks the wheel differential to provide improved traction under adverse road conditions.

Control Systems for Differential Lock

Two systems may be used to control the differential lock operation.

Transmission Low-Range Interlock Control System

The wheel differential is locked manually with the transmission in Low-Range. It is unlocked by the driver or unlocked when the transmission is shifted out of Low-Range.

Note: The interlock system is preferred for vehicles equipped with an air-shifted, Low-Range transmission. It is designed to ensure the differential lock is not left engaged (and to prevent accidental engagement) when the transmission is in high range.

Direct Driver-controlled System

The driver manually locks and unlocks the wheel differential, using a cab-mounted electric switch (or air valve). The following description assumes the system includes a cab-mounted electric switch and a solenoid valve as shown in the illustration. An air valve may be substituted for these components.

Operation is as follows:

1. With control switch in the “unlock” position, the wheel differential functions normally.
2. When the control switch is placed in the “lock” position, the air supply solenoid valve opens and air pressure activates the shift cylinder. The shift fork is moved to engage the curvic clutches, which, in turn, lock the wheel differential.

3. When the control switch is placed in the “unlock” position, air pressure supply to the shift cylinder is shut off and air pressure is released from the cylinder. A compression spring moves the shift fork to disengage the curvic clutch and unlock the wheel differential.

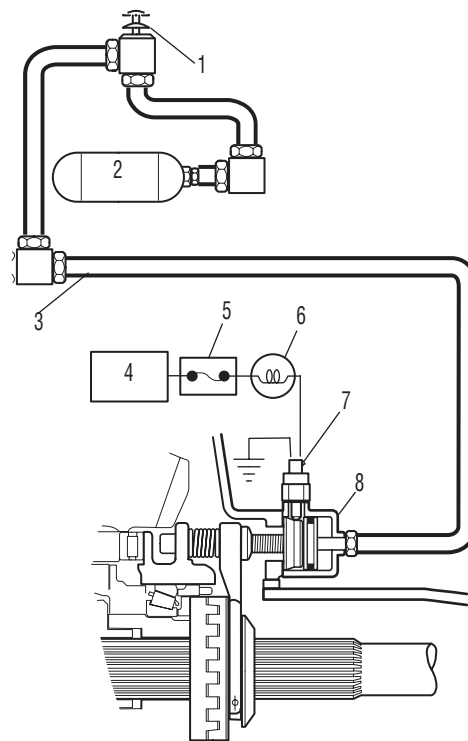

- 1— Cab-mounted control valve (plunger in—valve open)
- 2— Dry air supply tank 80–120 PSI
- 3— Preferably equal in length
- 4— Power supply
- 5— Fuse or circuit breaker
- 6— Indicator light or audible signal
- 7— Wheel differential lock indicator switch (part of axle assembly)
- 8— Rear axle wheel differential lock air shift cylinder (part of axle assembly)

Wheel Differential Lock

The Spicer Wheel Differential Lock is an optional feature for Spicer Axles. In operation, it positively locks the wheel differential, to provide improved traction under adverse road conditions.

The differential lock is driver-controlled through an electric switch or air valve mounted in the cab. The locking mechanism is air-operated to engage a mechanical clutch and lock the wheel differential. It is spring-operated to disengage the lock and permit the wheel differential to function normally.

The wheel differential lock consists of three major assemblies.

Shift Cylinder Assembly

- Operates a shift fork and push rod assembly.

Shift Fork and Push Rod Assembly

- Engages and disengages the differential lock curvic clutch assembly.

Curvic Clutch Assembly

- Consists of a sliding clutch splined to a axle shaft and a fixed clutch which is splined to the differential case hub.

The differential lock also includes a selector switch (electric) which senses clutch engagement and sends an electrical signal to a cab mounted indicator light (or an audible signal device).

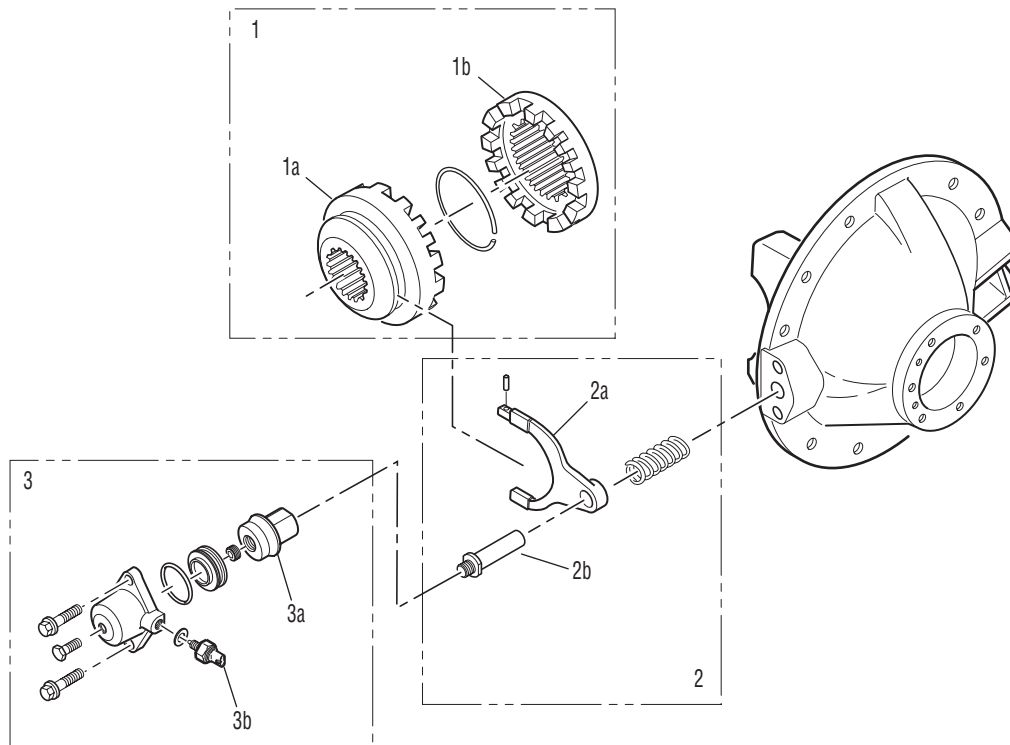

- 1— Curvic clutch assembly
- 1a—Sliding clutch
- 1b—Fixed clutch
- 2— Shift fork and pushrod assembly
- 2a—Shift fork
- 2b—Pushrod
- 3— Shift cylinder assembly
- 3a—Piston driver
- 3b—Selector switch

Wheel Differential Lock Operation

Differential Lock Engaged

Air pressure applied to the shift cylinder moves the piston, push rod, shift fork and the sliding curvic clutch as an assembly. The sliding curvic clutch engages the fixed curvic clutch.

The sliding clutch is splined to the axle shaft. The fixed clutch is splined to the differential case hub. Engaging the two clutches locks the wheel differential thus preventing wheel differential action.

Differential Lock Disengaged

When air pressure at the shift cylinder is released, a compression spring (mounted on the push rod) moves the push rod, shift fork and sliding clutch as an assembly. The sliding clutch moves out of engagement with the fixed clutch. The wheel differential is unlocked and operates normally.

Differential Lock Engagement Indicator

Differential lock engagement is detected by a switch (electric) mounted on the differential carrier. An actuator, mounted in the piston cover, operates the switch.

When the shift fork moves to engage the differential lock, the switch actuator moves away from the switch, allows the switch to close and sends an electrical signal to turn on a cab-mounted indicator light (or an audible signal).

When the shift fork moves to disengage the differential lock, the compression spring also moves the pushrod actuator to contact the switch. The switch is opened and turns off the cab-mounted indicator light (or the audible signal).

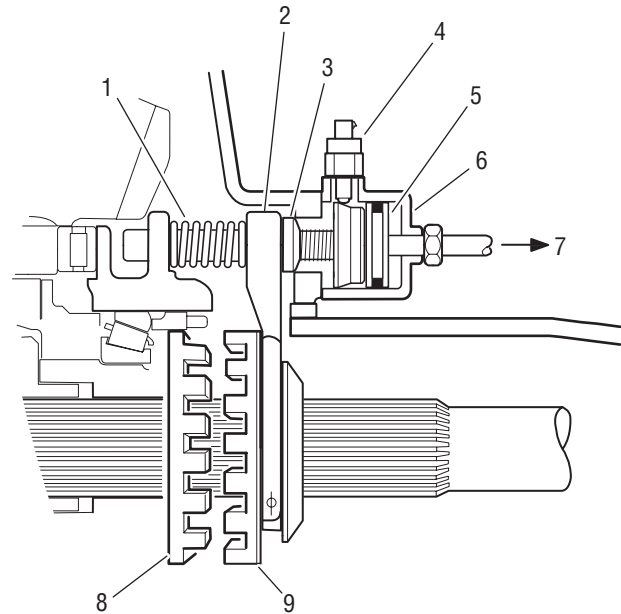
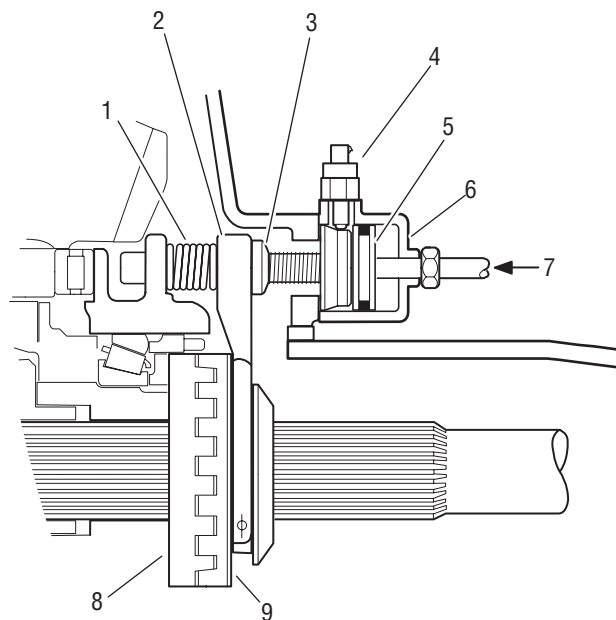

Differential Lock Engaged

- 1 - Spring is compressed
- 2 - Shift Fork
- 3 - Pushrod
- 4 - Selector switch
- 5 - Piston
- 6 - Shift cylinder
- 7 - Air pressure applied engages clutches
- 8 - Fixed clutch splined to differential case
- 9 - Sliding clutch splined to axle shaft

Differential Lock Disengaged

- 1 - Spring is decompressed
- 2 - Shift fork
- 3 - Pushrod
- 4 - Selector switch
- 5 - Piston
- 6 - Shift cylinder
- 7 - Air pressure applied disengages clutches
- 8 - Fixed clutch splined to differential case
- 9 - Sliding clutch splined to axle shaft

Rear Drive Axle Parts - Exploded View

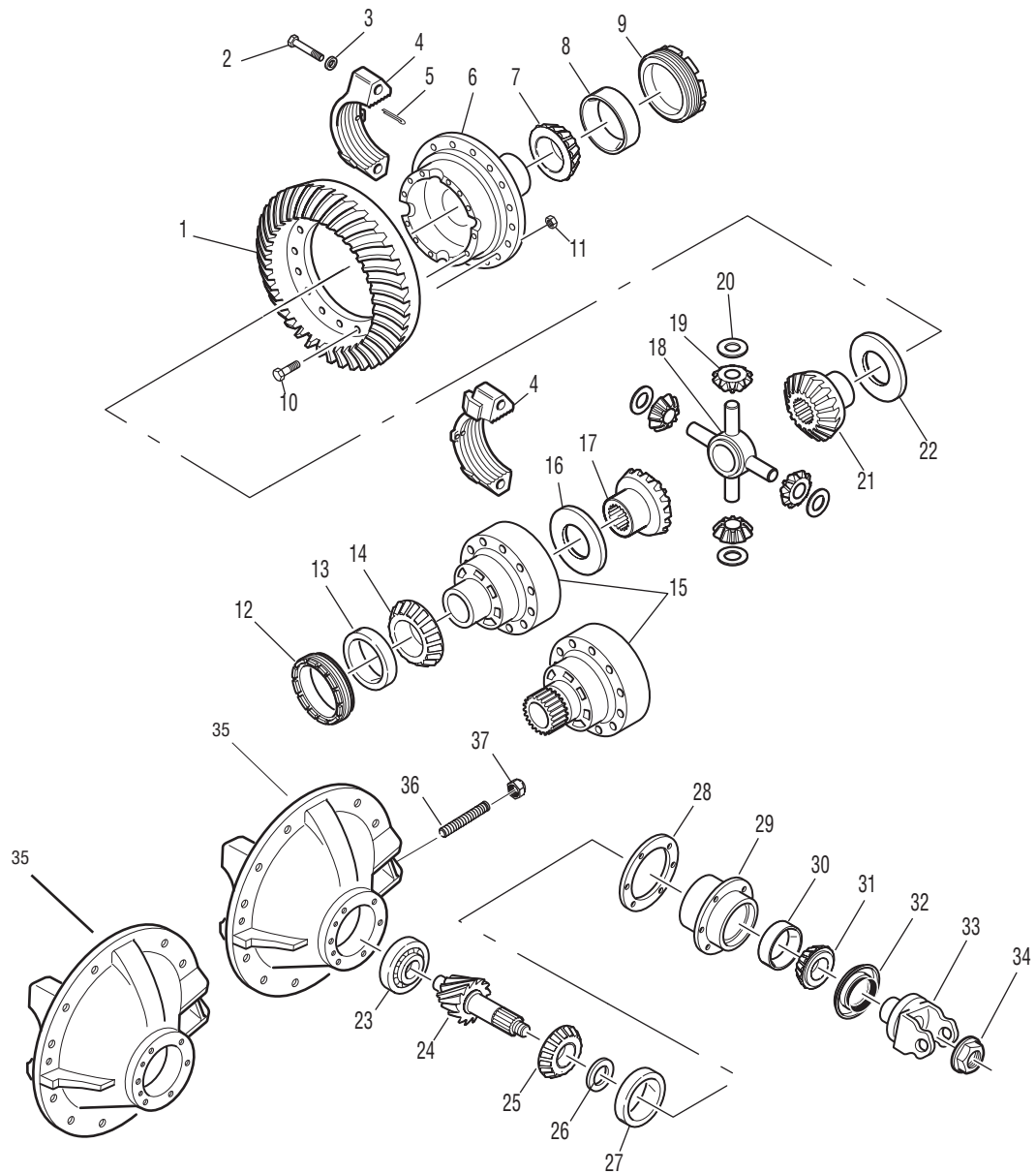

- | | | |
|----------------------------------|----------------------------------|------------------------------------|
| 1— Ring gear | 14—Plain half bearing cone | 27— Inner pinion bearing cup |
| 2— Carrier cap bolt | 15— Plain half differential case | 28— Pinion cage shim |
| 3— Washer | 16— Side gear thrust washer | 29— Pinion cage |
| 4— Flange half carrier cap | 17— Side gear | 30— Outer pinion bearing cup |
| 5— Cotter pin | 18— Wheel differential spider | 31— Outer pinion bearing cone |
| 6— Flange half differential case | 19— Side pinion | 32— Pinion seal |
| 7— Flange half bearing cone | 20— Side pinion thrust washer | 33— Pinion yoke |
| 8— Flange half bearing cup | 21— Side gear | 34— Pinion nut |
| 9— Flange half bearing adjuster | 22— Side gear thrust washer | 35— R-head carrier or rear carrier |
| 10— Ring gear bolt | 23— Pinion pilot bearing | 36— Thrust bolt |
| 11— Nut | 24— Pinion | 37— Thrust bolt jam nut |
| 12— Plain half bearing adjuster | 25— Inner pinion bearing cone | |
| 13— Plain half bearing cup | 26— Pinion bearing spacer | |

Inter-Axle Speed Sensor Parts - Exploded View

Inter-Axle speed Sensor

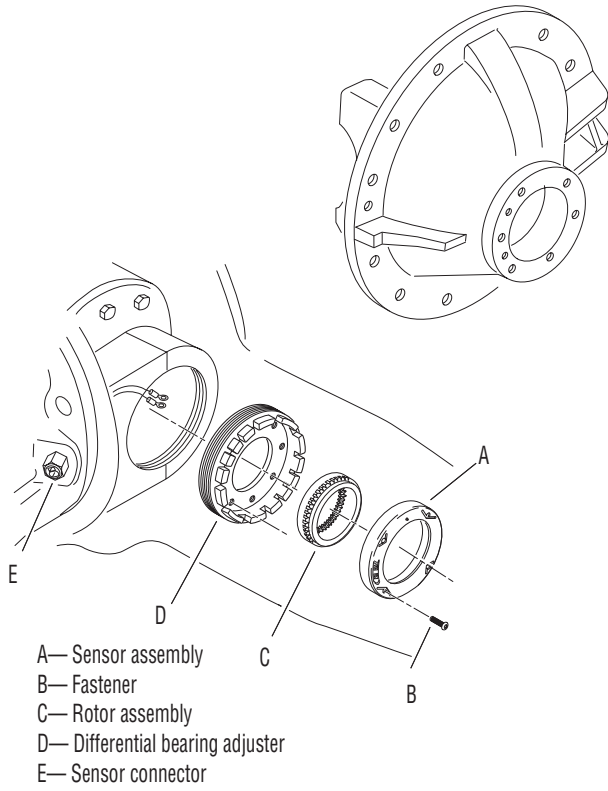

Wheel Differential Lock Assembly

Type 1

- 1 - Seal
- 2 - Piston
- 3 - O-ring
- 4 - Piston cover
- 5 - Capscrew
- 6 - Cover retainer
- 7 - Cervic clutch
- 8 - Spring
- 9 - Spring washer
- 10 - Set Screw
- 11 - Push rod
- 12 - Set screw
- 13 - Clutch fork
- 14 - Sliding cervic clutch
- 15 - Snap ring

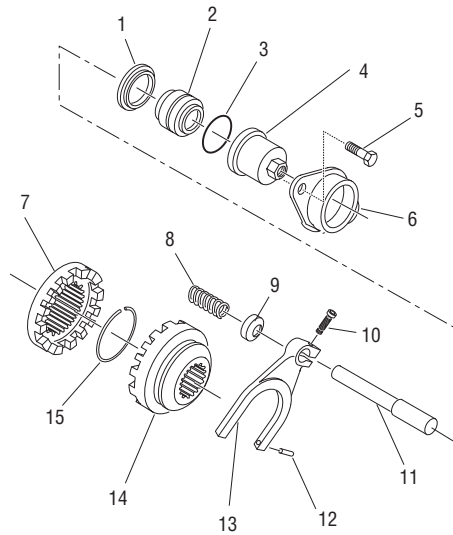

Type 2

- 1 - Fixed cervic clutch gear
- 2 - Snap ring
- 3 - Sliding clutch gear
- 4 - Spring pin
- 5 - Shift fork
- 6 - Compression spring
- 7 - Push rod
- 8 - Piston driver
- 9 - Set screw
- 10 - Piston
- 11 - O-ring
- 12 - Switch
- 13 - Plastic washer
- 14 - Piston cover
- 15 - Capscrew—flange head
- 16 - Capscrew—manual engagement
- 17 - Gasket

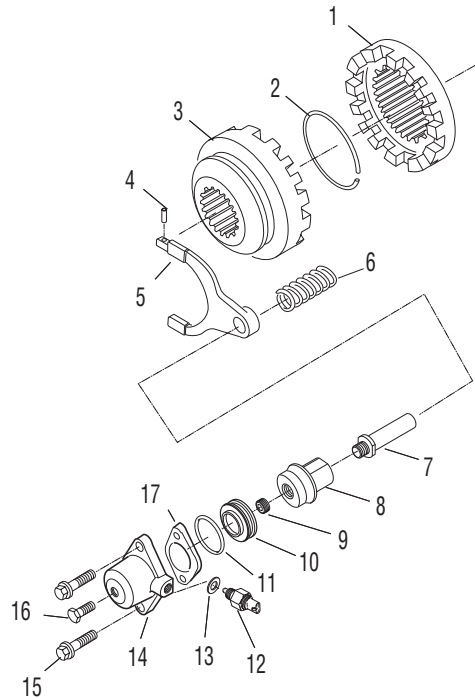

Housing and Output Shaft Assembly Parts - Exploded View

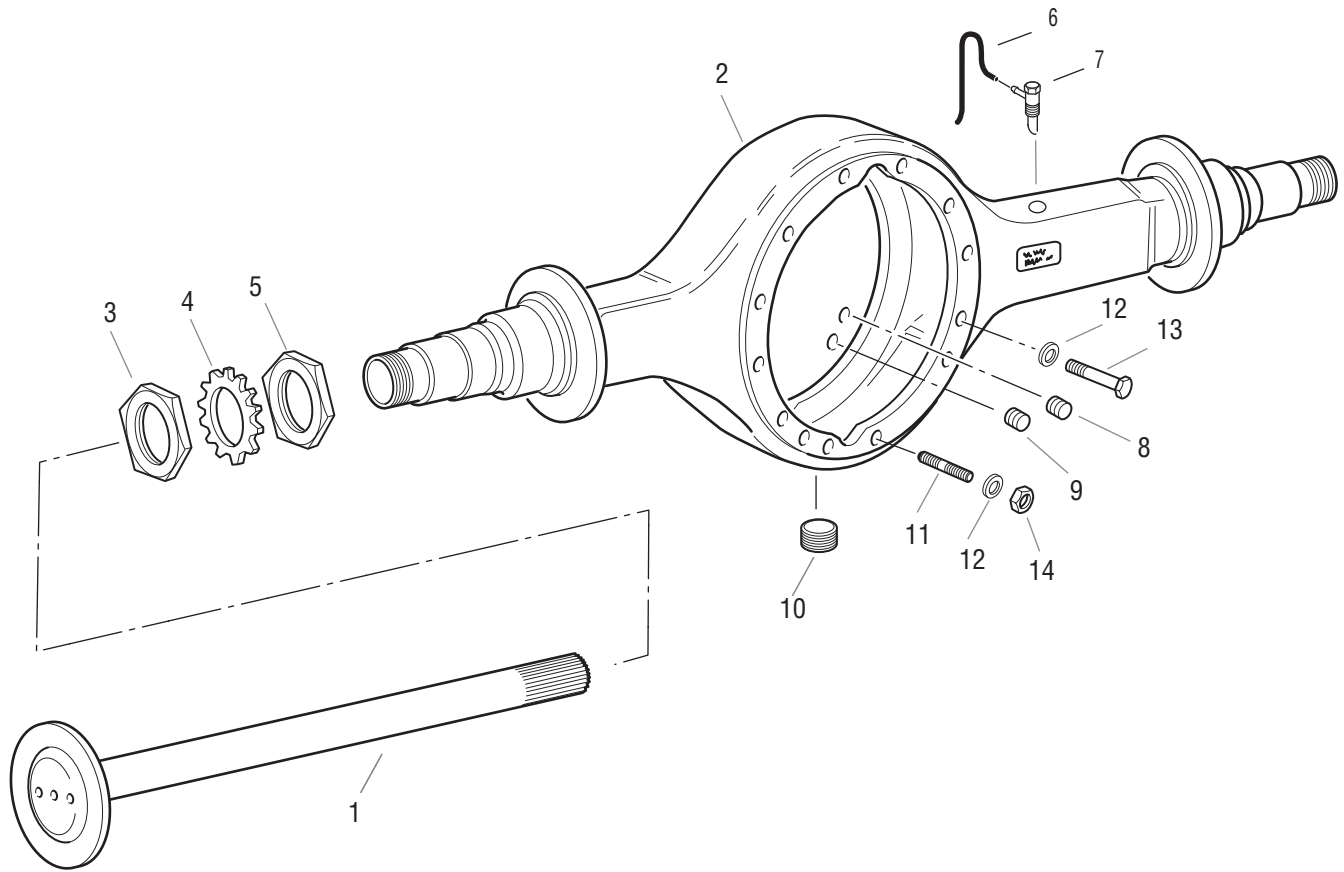

61510-8-95

- 1 - Axle shaft
- 2 - Housing
- 3 - Outer nut
- 4 - Lock washer
- 5 - Inner nut
- 6 - Housing breather tube
- 7 - Housing breather fitting
- 8 - Fill plug
- 9 - Oil sensor plug
- 10 - Drain plug
- 11 - Housing stud
- 12 - Hardened washer
- 13 - Carrier capscrew
- 14 - Nut, stud

Service Procedure

Fastener Torque Specifications

Fastener	Axle Model	Class	Size	Tool Size	Lbs.-ft.	N•m
Differential Case Cap-screw	15040, 19050, 19055	10.9	M12 x 1.75	18mm	70 - 88	95 - 119
	19060, 21/22 series axles	10.9	M14 x 2	18mm 12pt	114 - 140	155 - 190
	23070, 23080, 23085, 23090, 26080, 26085, 26090, 30080	10.9	M16 x 2	24mm	177 - 218	240 - 296
	23105, 26105, 30105	8	.625-11	15/16	165 - 195	224 - 264
Ring Gear Nut	15040, 17060, 19060, 21060	12	M14 x 1.5	21mm	215 - 255	292 - 346
	19/21/22 series axles (except 21080)	12	M16 x 1.5	24mm	215 - 255	292 - 346
	21080, 23070, 23080, 23085, 26080, 26085, 30080	12	M18 x 1.5	27mm	325 - 395	441 - 536
	23105, 26105, 30105		.750-16	1 1/8	275 - 300	373 - 407
Pinion Bearing Cage Capscrew	15/19 series axles	10.9	M14 x 2	21mm	114 - 140	155 - 190
	21060, 21065, 21080, 22060, 22065, 23070, 23080, 23085, 23090, 26080, 26085, 26090, 30080	10.9	M16 x 2	24mm	117 - 218	240 - 296
	23105, 26105, 30105	5	.750-10	1 1/8	240 - 300	325 - 407
Diff Bearing Cap Cap-screw	15040	12.9	M16 x 2	24mm	117 - 218	240 - 296
	19/21/22 series axles, 23070, 23080, 23085, 26080, 26085, 30080	12.9	M20 x 2.5	30mm	350 - 428	475 - 580
	23105, 26105, 30105	8	.8125-10	1 1/8	370 - 430	502 - 583
Diff Carrier To Housing Capscrew	15040, 19050	12.9	M12 x 1.75	18mm	85 - 103	115 - 140
	19055, 19060, 21/22 series axles 23070, 23080, 23085, 23090, 26080, 26085, 26090, 30080	12.9	M16 x 2	24mm	230 - 270	312-- 366
	23105, 26105, 30105	5	.625-11	15/16	160 - 176	217 - 239
Carrier to Housing Nut	All 19/21/22/23/30 series axles	12	M16 x 1.5	24mm	199 - 244	270 - 331
Magnetic Plug (Fill)	All Models		13/16	7/8 wrench	40 - 60	54 - 81
Oil Drain Plug	All Models			1/2 drive	40 - 60	54 - 81
Thrust Screw Jam Nut	All Models	4	M24 x 2	36mm	148 - 181	201 - 245
Pinion Nut	15040, 19050, 19055	-	M30 x 1.5	41mm	376 - 461	510 - 625

Fastener Specifications

Fastener	Axle Model	Class	Size	Tool Size	Lbs.-ft.	N•m
Pinion Nut (Continued)	17060, 19060, 21/22 series axles	-	M36 x 1.5	55mm	575 - 703	780 - 953
	21080, 23080, 26080, 30080	-	M42 x 1.5	55mm	840 - 1020	1139 - 1383
	23070, 23085, 26085	-	M42 x 1.5	55mm	789 - 966	1070 - 1310
	23105, 26105, 30105	-	1.75-12	2 1/4	840 - 1020	1139 - 1383
ABS Sensor Assy Fasteners	All Models	-	#1024 x 7/8	1/8 Allen	Finger Tight + 1 Turn	
Axle Shaft to Wheel Hub Nut	All Models	-	.500-20	11/16	55 - 71	75 - 96
		-	.625-18	15/16	170 - 190	230 - 258
		-	.750-16	1 1/8	285 - 345	386 - 468

Misc. Diff Lock Only Specifications						
Fastener	Axle Model	Class	Size	Tool Size	Lbs.-ft.	N•m
Diff Lock Shift Cylinder Bracket Screw	All Models	8.8	M10- x 1.5	13mm	28 - 35	38 - 47
Shift Fork Capscrew	All Axles where used	12.9	M8 x 1.25	6mm Allen	12 - 15	16 - 20
Selector Switch	All Models		M12 x 1.5	24mm	10 - 12	14 - 16
Diff Lock Cylinder Shipping Screw	All Models	-	.250-18	Snug to Engage Clutch Teeth		

Note: In the previous charts, axle models are listed either specifically or referred to by "Series" axles. The chart below denotes the possible models being referred to in this manual and in the previous charts.

Series	Possible Models
15	15040
17	17060
19	19050, 19055, 19060
21	21060, 21065, 21080, 21090
22	22060, 22065
23	23070, 23080, 23085, 23090, 23105
26	26080, 26085, 26090, 26105
30	30080, 30105

Note: Fasteners using self-locking thread "Patches" may be reused if not damaged, but should be secured by a few drops of Loctite #277 on threaded surface. Reused fasteners should be wiped clean of excess oil but do not require special cleaning.

Note: Correct tightening torque values are extremely important to assure long Spicer life and dependable performance. Under-tightening of attaching parts is just as harmful as over-tightening.

Fastener Specifications

Note: Exact compliance with recommended torque values will assure the best results.

Axle Model	Pinion Nut Part No.	Washer Part No.	Thread Size	Socket Size
15040	210133	210144	M30 x 1.5	41mm
19050	210133	210144	M30 x 1.5	41mm
19055	210089	210090	M36 x 1.5	55mm
17060	127589	not used	M36 x 1.5	55mm
19060	127589	not used	M36 x 1.5	55mm
21060	127589	not used	M36 x 1.5	55mm
21065	210089	210090	M36 x 1.5	55mm
21080	128049	not used	M36 x 1.5	55mm
21090	210089	not used	M36 x 1.5	55mm
22060	127589	not used	M36 x 1.5	55mm
22065	210089	210090	M36 x 1.5	55mm
23070	210508	210509	M42 x 1.5	55mm
23080	128049	not used	M42 x 1.5	55mm
23085	128049	not used	M42 x 1.5	55mm
23090	128049	not used	M42 x 1.5	55mm
23105	95262	not used	1.75-12	2.25"
26080	128049	not used	M42 x 1.5	55mm
26085	210508	210509	M42 x 1.5	55mm
26090	210508	210509	M42 x 1.5	55mm
26105	95262	not used	1.75-12	2.25"
30080	128049	not used	M42 x 1.5	55mm
30105	95262	not used	1.75-12	2.25"

Thread Size Identification

M12	X	1.75
Nominal Diameter (mm)		Thread Pitch (mm)

Class Identification (Fastener Strength)

Strength (class) is identified by numbers on the bolt head or nut face. Increasing numbers represent increasing strength.

Bolts and cap screws



Nuts



For specifying or service assistance, call 1-877-777-5360 or visit our website at www.dana.com

Dana Commercial Vehicle Products Group

3939 Technology Drive
Maumee, Ohio, USA 43537

www.dana.com



SPICER[®]

Drivetrain Products