



Front Bumper Mounted Engine Block Heater Plug

UPDATE

Models Affected: Certain 2013, 2014, Ford 6.8L Propane Visions Equipped With An Optional Engine Block Heater

PROCEDURE

WARNING: Always follow all Federal, State, Local, and Shop safety standards and use proper safety equipment when performing these procedures. Observe all safety precautions to secure the bus from rolling. Park the bus on a level surface, apply parking brakes, turn off engine and remove keys. Chock wheels.

The first Visions equipped with the Ford 6.8L propane engine and optional engine block heater did not have a bumper mounted receptacle connection. The following instruction is available to install the bumper mounted receptacle connection if desired.

Existing cable assembly (BB #10020897) has a standard 120V plug with a rubber cover. It is secured to a bracket just behind the front bumper. See photo below:



Existing cable assembly
10020987 with non-bumper
mounted receptacle connection.

For improved accessibility the following update procedure is available.

1. Remove the current engine block heater cable assembly #10020897 shown above.
2. Install new engine block heater cable assembly #10027615 and items 6 thru 10 as shown in the illustration on the following page.

S U I 3 0 3

S E R V I C E U P D A T E



BLUE BIRD

UPDATE

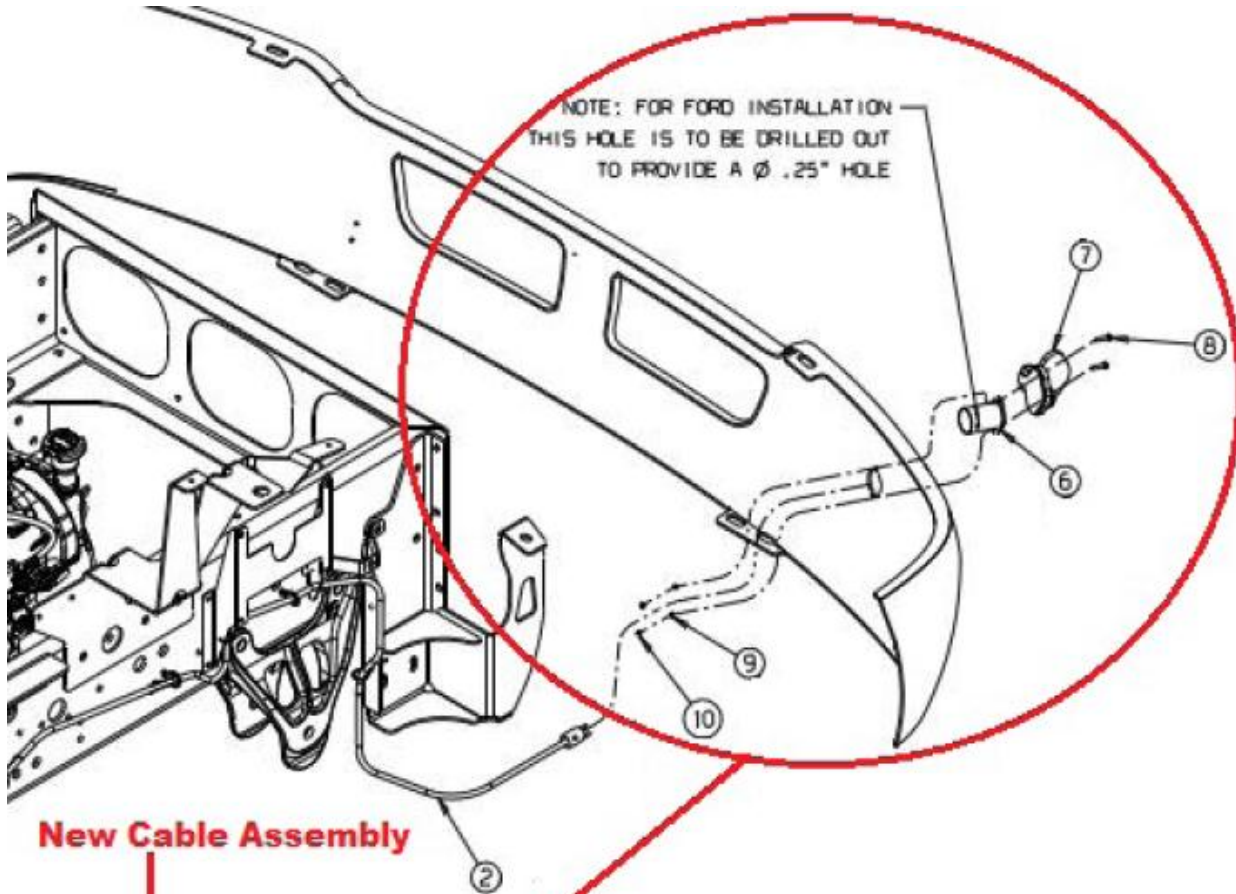

KEY	PART NUMBER	DESCRIPTION	QTY
1	10020896	HEATER ASSY, BLOCK, ENGINE, FORD 6.8L	1
2	10027615	CABLE ASSY, HEATER, ENGINE BLOCK, FORD 6.8L, PT1	1
3	10020892	CAPSCREW, HEX HD, FLNGD, M8 X 20, FORD W714605	1
4	00006378	BRACKET, MTG, GRID HTR, WRG, CLA, ISC CUMHD&TORE	1
5	00024076	TIE, CABLE, NYLON, BUTTON HD, 14, 75L X .22V	5
6	01570035	HOUSING, PLASTIC, KIM, HOTSTART	1
7	01570027	COVER ASSY, PLASTIC, KIM, HOTSTART	1
8	01315100	SCREW, MACH, 10-32X1, PHI, PAN HD, BLK FLUORCARB	2
9	02001162	LOCKWASHER, SPLIT RING, 3/16, MED, YEL ZN DICH	2
10	02001287	NUT, HEX HD, 10-32, YEL ZN DICH	2

3. Return bus to service.