

TOYOTA | **2012**

NORTH AMERICAN **ENVIRONMENTAL REPORT**

TABLE OF CONTENTS

HOME PAGE.....	3
VISION & ACTION	6
Dear Readers.....	10
Environmental Strategy.....	13
Environmental Governance.....	17
Environmental Management & Compliance.....	18
GREEN INNOVATION	22
Vehicle Efficiency & Emissions	24
Chemical Management.....	32
Future Transportation.....	36
ECO-EFFICIENT OPERATIONS.....	49
Air Emissions	52
Biodiversity.....	54
Energy & Greenhouse Gases	58
Green Building	73
Waste Minimization	76
Water	82
SUPPORTING BUSINESS PARTNERS.....	89
Suppliers	90
Dealerships	94
STRENGTHENING COMMUNITIES.....	99
Signature Partnership: National Audubon Society	102
Environmental Stewardship	105
Environmental Education.....	110
Local Community Engagement.....	114

TOYOTA | **2012**

NORTH AMERICAN **ENVIRONMENTAL REPORT**

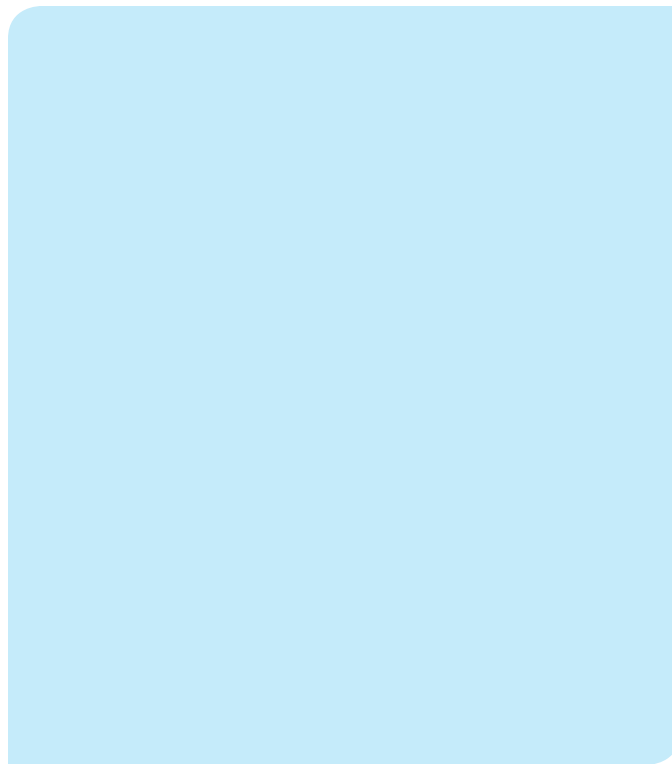



[> HOME PAGE](#)

Welcome to Toyota's 2012 North American Environmental Report. Here you will find information about our environmental activities in the United States, Canada and Mexico.

Information, data and stories cover all aspects of the vehicle life cycle—research and development, manufacturing, logistics and sales. We also describe our relationships with suppliers and dealerships, as well as how we support environmental stewardship and education initiatives.

This report covers the Toyota, Lexus and Scion brands in North America. The period covered in this report is fiscal year 2012 (April 1, 2011 through March 31, 2012) and product model year 2012. If data is presented with different dates, this is clearly indicated.

We listened to your comments and suggestions about last year's report and used them to improve this report. We've reorganized the issues to make things easier to find and easier to read, and we've added more in-depth information to a number of stories. We would appreciate your feedback. You may participate in a survey found [here](#).

This report was published in November 2012.

CONTACT:

Environmental Report Manager | 601 Lexington Ave, 49th Floor, New York, NY 10022

© 2012

www.toyota.com (USA) | www.toyota.ca (Canada) | www.toyota.com.mx (Mexico)

TOYOTA

2012

NORTH AMERICAN **ENVIRONMENTAL REPORT**

VISION & ACTION

- > DEAR READERS**
- > ENVIRONMENTAL STRATEGY**
- > ENVIRONMENTAL GOVERNANCE**
- > ENVIRONMENTAL MANAGEMENT
& COMPLIANCE**

Vision & Action is a chapter in the Toyota 2012 North American Environmental Report. Read the entire report online at Toyotaenvironmental.com or scan the QR code to access the report with your mobile device.





> VISION & ACTION

Respect for the Planet.
Simply stated, this is
Toyota's commitment to
the environment.

We challenge ourselves to minimize environmental impacts at all stages of the vehicle life cycle: in research and development, manufacturing, logistics and sales. We look at our own operations as well as those of key business partners—suppliers and dealerships. And, we partner with our communities to support environmental programs and initiatives.

Our success comes only by engaging the talent and passion of our employees, who believe there is always a better way. This conviction is rooted in the two pillars of the Toyota Way: **Continuous Improvement**: *kaizen* (change for the better) with standardized work, an evolutionary process that eliminates inefficiencies; and **Respect for People**: valuing and empowering the individual and the team, essential to making *kaizen* possible.

Toyota has built these pillars into its corporate culture; the result is a learning organization that believes in *jidoka*, or stopping to get things right. The Japanese word *hansei*, translated loosely as reflection, is what happens when one of our employees stops to examine a completed project. When a project finishes at Toyota, we use *hansei* to evaluate what went well and what did not. We then methodically try to preserve what went well and create countermeasures for what did not. These lessons are incorporated into the standard process so that when we repeat it, we improve over the last time. Finally, we share these insights with our colleagues so that they can learn as well, in a process we call *yokoten*.

In environmental terms, the improvements we seek are those that help us better manage issues such as waste, air emissions, energy consumption, water use, vehicle fuel efficiency and tailpipe emissions. *Hansei* is both an intellectual and emotional introspection. The individual must recognize the gap between the current situation and the ideal, take responsibility for finding solutions, and commit to a course of action. The examination involves a review of successes and failures, to determine what works and what needs to be improved. *Hansei* leads to ideas for *kaizen* and *yokoten*, the sharing of best practices from one location to another.

Even more so than in recent years, 2012 was a time of *hansei* in North America. We looked closely at how we operate and made some significant changes to streamline regional management, speed up decision-making and respond faster to customer needs. We reevaluated our environmental strategy and are working towards a more coordinated approach to measuring and tracking performance across the North American region.

Throughout this report, we describe instances where *hansei* is helping us identify ways to improve our environmental performance. We seek to design and produce more efficient and cleaner-emitting cars, to structure our operations so as to tread more lightly on the earth, and to enrich the lives of people in our communities. Our aspirations are part of a long-term view of sustainable growth that shows respect for the planet at every turn.

DEAR READERS,

We are pleased to present Toyota's 2012 North American Environmental Report. Here you will find information about our environmental activities in the United States, Canada and Mexico, with a focus on progress during fiscal year 2012. Highlights of our performance are provided in **2012 At A Glance** and at the beginning of each chapter.

Last year, we reported on the completion of our second five-year environmental action plan and committed to publishing new goals and targets through 2016. Over the course of this past year, we reflected on our environmental performance and reexamined our ultimate goals. This process of reflection, known as *hansei*, helped us recognize the value and importance of coordinated environmental management across Toyota's North American companies. So we began working on a new environmental action plan that reflects better coordination among the various functions and divisions in the region. This plan will provide the foundation for a stronger and more focused environmental strategy in North America. We look forward to sharing it with you next year.

In the meantime, we continue to address a number of environmental challenges. Climate change remains the most prominent of these challenges. We report on our approach in terms of the vehicle—fuel economy and advanced powertrain technologies such as plug-in hybrids, and in terms of operations—reducing energy consumption and corresponding greenhouse gas emissions and supporting renewable energy. Our record speaks for itself. We have the most fuel-efficient fleet of any full-line auto manufacturer, and Toyota's first hybrid—the Prius—accounts for half of all hybrids on the road in North America. In 2012, we introduced the Prius *c* and Prius Plug-in Hybrid as the latest additions to the Prius Family. And for the eighth consecutive year, Toyota's North American manufacturing division received an **ENERGY STAR® Sustained Excellence award** for exhibiting exceptional leadership year after year in the ENERGY STAR program.

We believe water is our next big challenge. Water issues are beginning to rival climate change in the international spotlight, and we have begun to look more closely at how we manage water in the production of our vehicles and in maintaining our facilities. Thanks to the ingenuity and persistence of team members at our Cambridge, Ontario, plant, we have found a way to reduce annual water consumption by more than 13.2 million gallons (50,000 cubic meters). Imagine the savings once this is transferred to other locations. And imagine the impact of teaching students and local communities about water conservation—our plant in Princeton, Indiana, was honored as one of only two North American recipients of the **Water Champion award**.

We have over 37,000 employees working in office space, distribution centers and manufacturing plants across North America. We use green building principles to help us design, build, renovate and manage our facilities in a more sustainable manner. We also work with our network of dealerships to implement these same practices. We are leading the industry with 37 facilities certified to LEED®, including 11 of our own Toyota and Lexus sites and 26 Toyota and Lexus dealerships.

These accounts and many more can be found in this year's report. We describe how we support our commitment to respecting the planet, including several spotlight articles that describe in greater detail the strategy and approach we take to environmental performance. We are also pleased to recognize several individuals for their contributions to making our company more eco-efficient.

We hope you enjoy our story.



A handwritten signature in black ink that reads "Shigeki Terashi".

Shigeki Terashi
President and Chief Operating Officer
Toyota Motor North America, Inc.
Managing Officer
Toyota Motor Corporation



A handwritten signature in black ink that reads "Dian D Ogilvie".

Dian Ogilvie
Senior Vice President & Secretary
Toyota Motor North America, Inc.

2012 At A Glance

<p>Environmental Management & Compliance</p>	<ul style="list-style-type: none"> • In North America, 41 Toyota sites have an environmental management system certified to ISO 14001, the international standard on environmental management systems. • Over 600 suppliers to our North American plants are certified to ISO 14001. • Our North American manufacturing plants had zero violations and zero complaints, and our Canadian logistics sites achieved their 14th year with no dangerous goods violations.
<p>Green Innovation</p>	<ul style="list-style-type: none"> • In the United States, Toyota offers the most fuel-efficient fleet of any full-line manufacturer. • We have been using bio-based plastics—plastics derived either wholly or in part from plant materials—in numerous parts and components for over a decade. • Driving range for the Prius Plug-in Hybrid is estimated as high as 540 miles on a single charge and single tank.
<p>Eco-Efficient Operations</p>	<ul style="list-style-type: none"> • Toyota's North American manufacturing division received another ENERGY STAR® Sustained Excellence award. • Cumulative savings from the use of returnable containers in our logistics division amounts to over 129 million pounds of wood and 48 million pounds of cardboard. • An improved reverse osmosis system at our Cambridge, Ontario, plant is saving 50,000 cubic meters (13.2 million gallons) of water per year.
<p>Supporting Our Business Partners</p>	<ul style="list-style-type: none"> • Toyota has shared its energy treasure hunt process with 180 Tier 1 suppliers to date. • Toyota is leading the industry with 26 dealerships in the U.S. and Canada certified to LEED®. • The Lexus of Henderson dealership in Henderson, Nevada, is the third Lexus dealership to achieve LEED Gold certification.
<p>Strengthening Communities</p>	<ul style="list-style-type: none"> • <i>TogetherGreen™</i>, funded by a \$20 million grant from Toyota, has supported nearly 900 volunteer events that improved or restored almost 13,000 acres. • In mid-2012, Toyota and Evergreen celebrated an important milestone: The Evergreen Learning Grounds program reached its one millionth Canadian child. • Toyota's plant in Indiana received the Water Champion award for their involvement in the World Water Monitoring Challenge™.

ENVIRONMENTAL STRATEGY

Environmental issues are a priority for Toyota around the globe. Our commitment to the environment is stated in Toyota's **Global Vision**, announced in 2011 and founded on a commitment to quality, constant innovation and respect for the planet. Our Global Vision articulates the kind of company we strive to be—a company that shows consideration to the environment and investigates and promotes sustainable systems and solutions. We continually seek new ways to build better cars and enrich the lives of others, and we aim to be an admired and trusted company wherever we conduct business.

This approach stems from the values embedded in our Guiding Principles and Earth Charter. These values guide Toyota's operations worldwide.

The Guiding Principles challenge the company to “be a good corporate citizen,” “dedicate ourselves to providing clean and safe products,” and “pursue growth in harmony with the global community.” Environmental responsibility is key to each of these.

Toyota's Earth Charter was developed in 1992 (and revised in 2000) to exemplify our comprehensive approach to managing environmental issues. The Earth Charter instructs us to strive for “growth in harmony with nature,” “zero emissions,” and “building close and cooperative relationships.” The charter's four Basic Policies and Action Guidelines are listed in Figure 1.

TOYOTA GLOBAL VISION

Toyota will lead the way to the future of mobility, enriching lives around the world with the safest and most responsible ways of moving people.

Through our commitment to quality, constant innovation and respect for the planet, we aim to exceed expectations and be rewarded with a smile.

We will meet challenging goals by engaging the talent and passion of people, who believe there is always a better way.

TOYOTA'S GUIDING PRINCIPLES

Adopted January 1992, Revised April 1997

1. Honor the language and spirit of the law of every nation and undertake open and fair corporate activities to be a good corporate citizen around the world.
2. Respect the culture and customs of every nation and contribute to economic and social development through corporate activities in local communities.
3. Dedicate ourselves to providing clean and safe products and to enhancing the quality of life everywhere through our activities.
4. Create and develop advanced technologies and provide outstanding products and services that fulfill the needs of customers worldwide.
5. Foster a corporate culture that enhances individual creativity and teamwork value, while honoring mutual trust and respect between labor and management.
6. Pursue growth in harmony with the global community through innovative management.
7. Work with business partners in research and creation to achieve stable, long-term growth and mutual benefits, while keeping ourselves open to new partnerships.

TOYOTA'S EARTH CHARTER (APRIL 2000)

The Toyota Earth Charter, published in 1992 and updated in 2000, describes Toyota's Basic Action Policy and Action Guidelines regarding environmental improvements.

I. BASIC POLICY

1. Contribute toward a prosperous 21st century society

Aim for growth that is in harmony with the environment, and set a challenge to achieve zero emissions throughout all areas of business activities.

2. Pursue environmental technologies

Pursue all possible environmental technologies, developing and establishing new technologies to enable the environment and economy to coexist.

3. Take action voluntarily

Develop a voluntary improvement plan based on thorough preventive measures and compliance with laws, that addresses environmental issues on global, national and regional scales, while promoting continuous implementation.

4. Work in cooperation with society

Build close and cooperative relationships with a wide spectrum of individuals and organizations involved in environmental preservation, including governments, local municipalities and related companies and industries.

II. ACTION GUIDELINES

1. Always be concerned about the environment

- Work toward achieving zero emissions at all stages, i.e., production, utilization and disposal;
- Develop and provide products with top-level environmental performance;
- Pursue production activities that do not generate waste;
- Implement thorough preventive measures;
- Promote businesses that contribute toward environmental improvement.

2. Business partners are partners in creating a better environment

Cooperate with associated companies.

3. As a member of society

- Actively participate in social actions;
- Participate in creation of a recycling-based society;
- Support government environmental policies;
- Contribute to nonprofit activities.

4. Toward better understanding

Actively disclose information and promote environmental awareness.

To translate Toyota’s vision of *Respect for the Planet* into concrete action, Toyota relies on its environmental action plan process. The process for developing an EAP begins with the parent company in Japan, Toyota Motor Corporation (TMC). Every five years, TMC develops a global five-year environmental action plan (EAP).

The process of developing an environmental action plan relies on fundamentals of the Toyota Way, a means for employees around the world of thinking about and acting on environmental challenges. The two pillars of the Toyota Way—“Continuous Improvement” and “Respect for People”—are core values that help us constantly look for ways to reduce environmental impacts, and encourage us to respect and empower the individual and the team to take responsibility and maximize results.

The environmental action plan is a critical tool used to help us manage our environmental impacts across all aspects of our business. It provides clear direction to all business functions and creates a way for us to prioritize resources, measure progress and reassess performance in light of changing conditions.

Toyota companies around the globe use TMC’s plan to structure their own environmental action plans. By developing regional EAPs, Toyota ensures that local conditions and priorities are taken into account, while still providing a consistent framework for worldwide planning.

This past year, in the spirit of *hansei*, we have been examining our recently completed five-year action plan for North America to find ways to better coordinate environmental activities across the various business functions. In the past, our manufacturing plants, logistics sites and offices each approached environmental management separately, developing their own metrics and key performance indicators (KPIs). We are now working to align KPIs across all functions. Increased coordination among the North American companies will bring greater efficiency and improved performance. We look forward to sharing our new environmental action plan in next year’s report.

In this report, we describe environmental initiatives and performance in North America across our various business functions—research and development, manufacturing, logistics and sales. Information is organized by issue to allow for better readability and ease of navigation. In this report, we also describe progress against the one-year targets set by our operations in the following key performance areas:

- Compliance
- Air emissions
- Energy consumption
- Greenhouse gas emissions
- Waste minimization
- Water use

FG2 • FY2012 Targets and Results

	FY2012 ENVIRONMENTAL TARGETS	RESULTS
Compliance	Zero complaints and violations	X *Achieved by the manufacturing plants and the Canadian sales and logistics division. Target missed because of a shipping violation from a regional sales office in the U.S. The violation did not result in harm to people or the environment and countermeasures are being implemented.
Air Emissions	Maintain VOCs from the body paint process at manufacturing plants at 13.9 g/m ²	⊙ 13.7 grams per square meter of vehicle surface area coated
Energy Consumption	Reduce energy consumption at manufacturing plants to 7.28 MMBtus per vehicle produced	○ 7.28 MMBtus per vehicle produced
Greenhouse Gas Emissions	Reduce GHG emissions at manufacturing plants to 0.80 metric tons CO ₂ per vehicle produced	⊙ 0.78 metric tons CO ₂ per vehicle produced
Waste Minimization	Reduce non-saleable waste from manufacturing plants to 17.80 kilograms per vehicle produced	X 18.78 kilograms per vehicle produced *The primary reason for missing the target is that we performed a number of “spring cleaning” events and plant refurbishment activities during planned non-production times last year. These cleaning events would have happened over the course of a longer time period, but we took advantage of the non-production times to complete these activities early.
	Achieve zero waste to landfill* at manufacturing plants *Defined as not sending waste directly to landfill (excluding ash from waste sent to incineration and waste-to-energy facilities)	Δ Achieved by 10 plants *Two plants missed the target. In addition, the TX plant missed the target because they are required by local law to send some waste to landfill (we are working with state officials to amend this requirement). The MS plant was only operating for a partial year so was not included in the target; they will be included in FY13.
Water Use	Reduce water usage at manufacturing plants to 0.92 kilogallons per vehicle produced	⊙ 0.90 kilogallons per vehicle produced

⊙ Target Exceeded ○ Target Achieved Δ On Track X Target Missed

ENVIRONMENTAL GOVERNANCE

In 2012, we created an Environmental Strategy Working Group composed of environmental experts and representatives from four of Toyota's North American companies:

- Toyota Motor North America, Inc. (TMA)
- Toyota Motor Engineering & Manufacturing North America, Inc. (TEMA)
- Toyota Motor Sales, U.S.A., Inc. (TMS)
- Toyota Canada Inc. (TCI)

This report contains information from these four companies.

The Working Group operates under the authority of a charter signed by each company's Chief Environmental Officer. The Working Group sets strategic direction and priority for environmental efforts across North America and reports to the North American Executive Committee. The Chief Environmental Officers are committed to champion the work of this group in an effort to promote their ability to effectively engage with stakeholders at all levels of the organization in understanding the operational, business, investment and public relations impacts of managing Toyota's environmental footprint.

FG3 • Environmental Governance for Toyota in North America

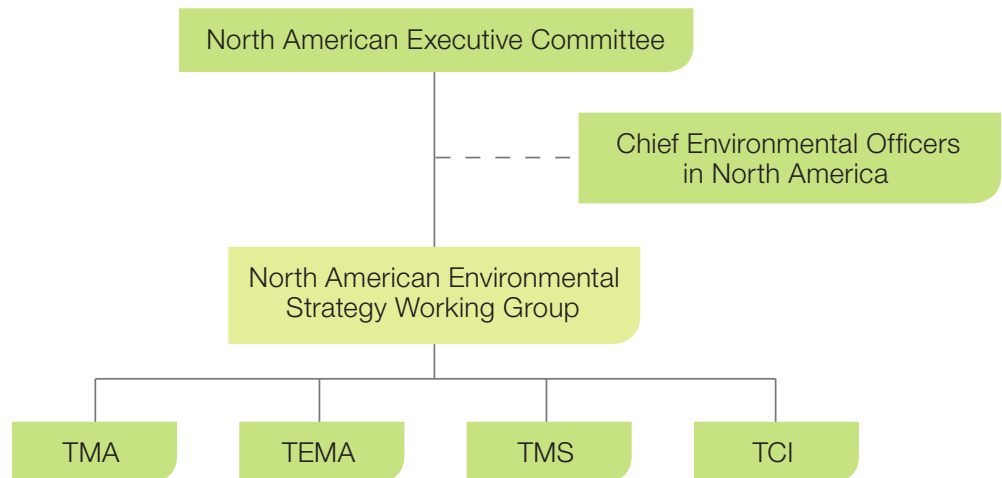

CHIEF ENVIRONMENTAL OFFICERS



Dian Ogilvie
Senior Vice President &
Secretary
Toyota Motor North
America, Inc.



Kevin M. Butt
General Manager
Toyota Motor Engineering
& Manufacturing North
America, Inc.



Christopher P. Reynolds
Group Vice President and
General Counsel
Toyota Motor Sales,
U.S.A., Inc.



Stephen Beatty
Managing Director
Toyota Canada Inc.

ENVIRONMENTAL MANAGEMENT & COMPLIANCE

Environmental management systems are an essential part of Toyota's overall effort to minimize risks and achieve leading levels of environmental performance. Each location's environmental management system (EMS) identifies significant environmental aspects and impacts and has corresponding controls, goals and targets to manage and gradually reduce these impacts over time.

An EMS is part of a redundancy of systems put in place to protect the environment. We have used and enhanced these systems in North America for 25 years. Our expertise has been recognized by suppliers who come to us to learn how we make an EMS successful. Employees from various functions frequently speak at events to share our knowledge with others. For example, Kevin Butt, General Manager/Chief Environmental and Safety Officer for Toyota Motor Engineering & Manufacturing North America, was a speaker in the Keynote Program for the Air and Waste Management Association's annual conference in San Antonio on June 19, 2012. His address was titled "Toyota's Approach to Sustainable Manufacturing."

In North America, 41 of our locations are certified to the International Organization for Standardization (ISO) 14001 standard. ISO 14001 is one of ISO's most successful management system standards. It has been adopted by well over 250,000 certified users in 155 countries. Recently, experts gathered in Berlin to discuss revisions to this standard. Sheena Donald, Specialist at Toyota's North American manufacturing headquarters in Erlanger, Kentucky, is one of these experts; she represents Toyota on Technical Committee 207. We are honored that Sheena is one of the 40 global experts working on the next generation of the ISO 14001 standard.



Sheena Donald, Specialist at Toyota's North American manufacturing headquarters in Erlanger, Kentucky, is one of 40 global experts on Technical Committee 207 working on the next generation of the ISO 14001 environmental management system standard.

In 2000, Toyota's manufacturing headquarters in North America released a set of Green Supplier Guidelines to encourage suppliers to support Toyota's environmental goals. These guidelines were updated in 2007 and extended to sales and logistics suppliers. The guidelines encourage suppliers to pursue third-party certification of their environmental management system. Over 600 suppliers to our North American plants are certified to ISO 14001.

PERFORMANCE

All of Toyota's North American manufacturing plants and logistics sites and several office complexes have an environmental management system certified to the ISO 14001 standard. These 41 locations are listed in Figure 4. Our plant in Delta, British Columbia, was the first in North America to achieve this certification and has maintained it for 15 consecutive years.

FG4 • ISO 14001 Certifications of Toyota's North American Facilities

	LOCATION	ORIGINAL CERTIFICATION DATE	DATE OF LATEST RECERTIFICATION
Manufacturing Plants	Manufacturing Headquarters in Erlanger, Kentucky	2000	2009
	Huntsville, Alabama	2004	2010
	Long Beach, California	1998	2010
	Princeton, Indiana	1999	2011
	Georgetown, Kentucky	1998	2010
	St. Louis, Missouri	1998	2010
	Troy, Missouri	1998	2010
	Blue Springs, Mississippi	2012	—
	Jackson, Tennessee	2007	2010
	San Antonio, Texas	2008	2010
	Buffalo, West Virginia	2000	2009
	Woodstock, Ontario	2009	2012
	Cambridge, Ontario	1998	2010
	Delta, British Columbia	1997	2009
	Baja California, Mexico	2006	2012
Vehicle Distribution Centers	Georgetown, Kentucky*	1998	2010
	Lafayette, Indiana	2008	2011
	Long Beach, California	1999	2011
	Port Newark, New Jersey	2000	2011
	Portland, Oregon	2004	2011
	Princeton, Indiana*	1999	2011
	San Antonio, Texas	2007	2010
	Toronto, Ontario	2002	2011
	Montreal, Quebec	2003	2011
Parts Distribution Centers	Aurora, Illinois	2004	2012
	Cincinnati, Ohio	2001	2010
	Glen Burnie, Maryland	2001	2011
	Hebron, Kentucky	2003	2012
	Kansas City, Missouri	2000	2010
	Mansfield, Massachusetts	2000	2012
	Ontario, California	2002	2011
	Portland, Oregon	1999	2011
	San Ramon, California	2001	2010
	Torrance, California	2001	2011
	West Caldwell, New Jersey	2003	2012
	Toronto, Ontario	2001	2011
	Vancouver, British Columbia	2002	2011
Sales and Regional Offices	Canadian Sales Headquarters in Toronto, Ontario	2001	2011
	Pacific Region and TFS	2002	2011
	Quebec Regional Office and TFS	2005	2011
	Atlantic Regional Office and TFS	2006	2011

*Vehicle distribution centers in Kentucky and Indiana are certified with the manufacturing plants. They do not have separate certifications, even though they are separately managed facilities.

COMPLIANCE

Our activities are subject to local, state, provincial and federal laws that regulate air emissions, water discharges, stormwater management, greenhouse gas emissions, waste treatment and disposal, and chemical management. These regulations vary by facility based on the type of equipment we operate and local requirements.

Toyota is one of a number of companies named as a potentially responsible party (PRP) at the Portland Harbor Superfund Site in Portland, Oregon, and at a waste management site in Calvert City, Kentucky. We continue to work on groundwater remediation at our Newark vehicle distribution center with the New Jersey Department of Environmental Protection and the New York/New Jersey Port Authority. At the Long Beach vehicle distribution center, we are working with the Port of Long Beach and the Regional Water Quality Control Board to monitor groundwater quality.

TARGET AND PERFORMANCE

Target: Zero violations, zero complaints (missed)

Our North American manufacturing plants had zero violations and zero complaints in fiscal year 2012. Our Canadian logistics sites achieved their 14th year with no dangerous goods violations.

Our U.S. sales and logistics company received a violation and paid a \$10,000 civil penalty for an undeclared shipment of aerosol insect repellent (a hazardous material) from a regional sales office. The violation did not result in harm to people or the environment. Short-term countermeasures have been instituted at the regional and area offices to help prevent a recurrence, and we are in the process of implementing long-term shipping and handling process enhancements.

FG5 • Complaints and Violations

DESCRIPTION	FY11	FY12
Complaint Cases	0	0
Notices of Violation	2	1

TOYOTA

2012

NORTH AMERICAN **ENVIRONMENTAL REPORT**

GREEN INNOVATION

- > VEHICLE EFFICIENCY &
EMISSIONS
- > CHEMICAL MANAGEMENT
- > FUTURE TRANSPORTATION

Green Innovation is a chapter in the Toyota 2012 North American Environmental Report. Read the entire report online at Toyotaenvironmental.com or scan the QR code to access the report with your mobile device.





To watch a short video about TOYOTA'S HYDROGEN FUEL CELL VEHICLES in the real world on your mobile device, scan the QR code below.



> GREEN INNOVATION

For more than 35 years, Toyota's North American engineering and research and development activities have been headquartered in Ann Arbor, Michigan.

Team members at our design and research centers are engaged in engineering design, prototype building, vehicle evaluation, evaluation and design of parts and materials, regulatory affairs, emissions certification and technical research. Toyota's Ann Arbor technical center is widely regarded as Toyota's leading technical center outside Japan.

A fundamental step in the design of our vehicles is *hansei*, which in Japanese means reflection. We reflect on the successes and failures of previous projects and review what can be improved going forward. Through this process, we are finding ways to innovate more “green” into our products, for example, by finding ways for our vehicles to go longer distances on fewer gallons of fuel and by minimizing the use of harmful chemicals in vehicle parts. We are also building a portfolio of advanced technologies to meet future mobility needs. All of these activities begin with research and development. Read on to find out more about Toyota’s green innovation.

REFLECTION

The Japanese word *hansei*, translated loosely as reflection, is what happens when one of our employees stops to examine a completed project. *Hansei* is both an intellectual and emotional introspection. The employee must recognize the gap between the current situation and the ideal, take responsibility for finding solutions, and commit to a course of action. When a project finishes at Toyota, we use *hansei* to evaluate what went well and what did not. We then methodically try to preserve what went well and create countermeasures for what did not. These lessons are incorporated into the standard process so that when we repeat it, we improve over the last time. Finally, we share these insights with our colleagues so that they can learn as well, in a process we call *yokoten*.

VEHICLE EFFICIENCY & EMISSIONS

The most common fuels used in vehicles across North America today are gasoline and diesel, both of which are derived from petroleum. The Energy Information Agency projects an increase in global petroleum demand of almost 20 percent over the next two decades, which will create continued upward pressure on the price of these fuels.

Gasoline and diesel contain mixtures of hydrocarbons that, when combusted in a vehicle engine, cause emissions of several types of air pollutants, including carbon dioxide, hydrocarbons, nitrogen oxides (NO_x) and carbon monoxide. These pollutants are linked to climate change, smog and acid rain, as well as a number of human health effects.

Toyota engineers are continually looking for ways to increase fuel economy and reduce emissions of pollutants from our vehicles. Vehicle weight, engine output, the application of new technologies and other factors are all evaluated to optimize fuel economy and tailpipe emissions, all before a vehicle is built. We describe our efforts and performance in these areas below.

FUEL ECONOMY & GHG EMISSIONS

Fuel economy is the distance a vehicle can be driven on a certain amount of fuel, measured in the United States as miles per gallon (mpg). Fuel consumption is the quantity of fuel burned over a defined distance, and in Canada is measured as liters of fuel burned per 100 kilometers traveled (L/100 km). The amount of fuel burned is directly related to emissions of carbon dioxide (CO₂), a greenhouse gas: The more fuel burned, the more CO₂ emitted.

The U.S. Environmental Protection Agency (EPA) and the National Highway Traffic Safety Administration (NHTSA) recently finalized fuel economy and greenhouse gas (GHG) emissions standards for 2017–2025 model year passenger cars and light trucks in the U.S. This is a continuation of the agreement reached between auto makers and EPA, NHTSA and the California Air Resources Board that established a coordinated national program for fuel economy and GHG emissions standards for 2012 through 2016 model year vehicles.

By 2016, the new vehicle fleet must meet a GHG standard of 250 grams of CO₂ per mile, equivalent to a Corporate Average Fuel Economy (CAFE) standard of 35.5 miles per gallon; by 2025 cars and light trucks are required to yield a combined 54.5 mpg.

Toyota in Canada supports a harmonized approach with the United States to setting emissions standards. The Canadian federal government introduced a greenhouse gas emission regulation under the Canadian Environmental Protection Act for the 2011 through 2016 model year that contains requirements similar to the GHG emission standards adopted in the U.S.

Toyota, along with the Alliance of Automotive Manufacturers, has been a strong advocate of a single national framework for fuel economy and vehicle GHG regulations. We believe the recent joint EPA-NHTSA final rule is on course to achieve that objective.

The standards present a significant challenge for our engineers and we expect multiple vehicle and powertrain technologies will be necessary to meet the challenge. Using Toyota Way principles, we evaluate vehicle powertrains, weight, aerodynamics and other design factors to find fuel-efficient combinations for our vehicles. Our technology portfolio approach, as well as our experience marketing hybrids and other advanced technologies provide a solid foundation for success. While climate change and fuel efficiency are priority management issues at all Toyota locations worldwide, our challenge is to find approaches that drive down fuel consumption and GHG emissions while still meeting customer demands for vehicle size, power, driving range and affordability—without sacrificing world-class vehicle safety performance.

For this reason, Toyota believes engines fueled by gasoline and diesel will remain a dominant source of vehicle power for the foreseeable future and that hybrid technology will play an increasingly important role. Many of our hybrid products are already capable of meeting their respective future targets, which is one reason hybrid technology is at the core of Toyota's compliance strategy.

We are moving ahead with our goal to offer hybrid options on all of our vehicles by 2020. During the 2012 New York International Auto Show, we introduced the all-new 2013 Lexus ES 300h. This is the first time the ES will be offered as a hybrid. The innovative hybrid engine design replaces the accessory belts with computer-controlled electric accessories to improve fuel economy, emissions and durability, while a near-zero evaporative fuel system helps reduce emissions of volatile organic compounds (VOCs). The ES 300h has an EPA fuel economy rating of 40 mpg combined.

The key to meeting the new standards will be offering hybrids and other technology options that consumers are able and willing to purchase in sufficient quantities. At this point, it is nearly impossible to predict consumer preference for 2025 model year vehicles since preferences will largely be determined by factors such as fuel price, economic conditions and technological progress—most of which are beyond an auto manufacturer's control. To ensure the standards remain practical in light of these uncertainties, the final rule calls for the feasibility of the 2022–2025 model year standards to be re-examined by 2018. Toyota supports this mid-term evaluation. We believe the evaluation should include the long-standing practice of treating vehicles and fuels as a system since higher octane and/or reduced sulfur can enable additional greenhouse gas emissions reductions and fuel savings from several engine technologies, while biofuels have the potential to reduce the carbon intensity of the fuel.

PERFORMANCE

In the United States, Toyota offers the most fuel-efficient fleet of any full-line manufacturer, while in Canada, we maintain the most fuel-efficient passenger car fleet. Toyota has been performing better than the required U.S. Corporate Average Fuel Economy (CAFE) standards and Canadian Car Company Average Fuel Consumption (CAFC) targets. As a result, CO₂ emissions from Toyota's new vehicles are below that of the industry average in both the U.S. and Canada, for cars and light-duty trucks.

Our CAFE and CAFC performance is driven by high volume sales of our most fuel-efficient vehicles, such as Prius and Corolla. As drivers grapple with some of the highest fuel prices in recent memory, Toyota has strengthened its portfolio of efficient cars with five recently introduced vehicles that offer a combined fuel economy ratings average of 44 mpg:

- Prius Plug-in Hybrid (EPA rated 50 mpg combined and 95 mpge in EV mode)
- Prius *c* (EPA rated 50 mpg combined)
- Scion iQ (EPA rated 37 mpg combined)
- Camry Hybrid (EPA rated 40 mpg combined for LE and XLE trim levels)
- Prius *v* (EPA rated 42 mpg combined)

These five new Toyota and Scion models represent a broad range of leading-edge drivetrain and engineering technologies that help them achieve a high level of efficiency. Hybrid Synergy Drive, extended electric vehicle range, generous use of lightweight high-strength steel, a focus on aerodynamics and the use of efficient continuously variable transmissions are among the measures employed that help these new vehicles attain a high level of fuel efficiency.

Toyota offers several models that achieved best-in-class fuel economy ratings in 2012. In the United States, the Prius *c* leads the EPA’s compact classification with 50 mpg combined. The Prius Liftback’s combined 50 mpg leads the EPA’s midsize category, and the midsize station wagon class is led by the 42 mpg combined offered by the Prius *v*. (These segment classifications are determined by EPA’s measurement of a vehicle’s interior volume; ratings exclude PHEV and pure EV vehicles; see www.fueleconomy.gov). In Canada, the Tacoma ranked first in the pick-up class and the Prius *v* ranked first in the station wagon class in **Natural Resources Canada’s ecoENERGY Awards for 2012**.

Toyota and Scion branded vehicles also represent six of the Top 10 EPA-rated Fuel Sippers for 2012 (excluding PHEV or pure EV products), and occupy three spots in that list’s top five. Toyota family vehicles found on the U.S Department of Energy’s Top 10 EPA-rated Fuel Sippers include:

- Prius *c* (ranked 1st, 53 city, 46 hwy)
- Prius (ranked 2nd, 51 city, 48 hwy)
- Prius *v* (ranked 4th, 44 city, 40 hwy)
- Toyota Camry Hybrid LE (ranked 7th, 43 city, 39 hwy)
- Toyota Camry Hybrid XLE (ranked 8th, 40 city, 38 hwy)
- Scion iQ (ranked 10th, 36 city, 37 hwy)

FG6 • U.S. Car Corporate Average Fuel Economy, or CAFE

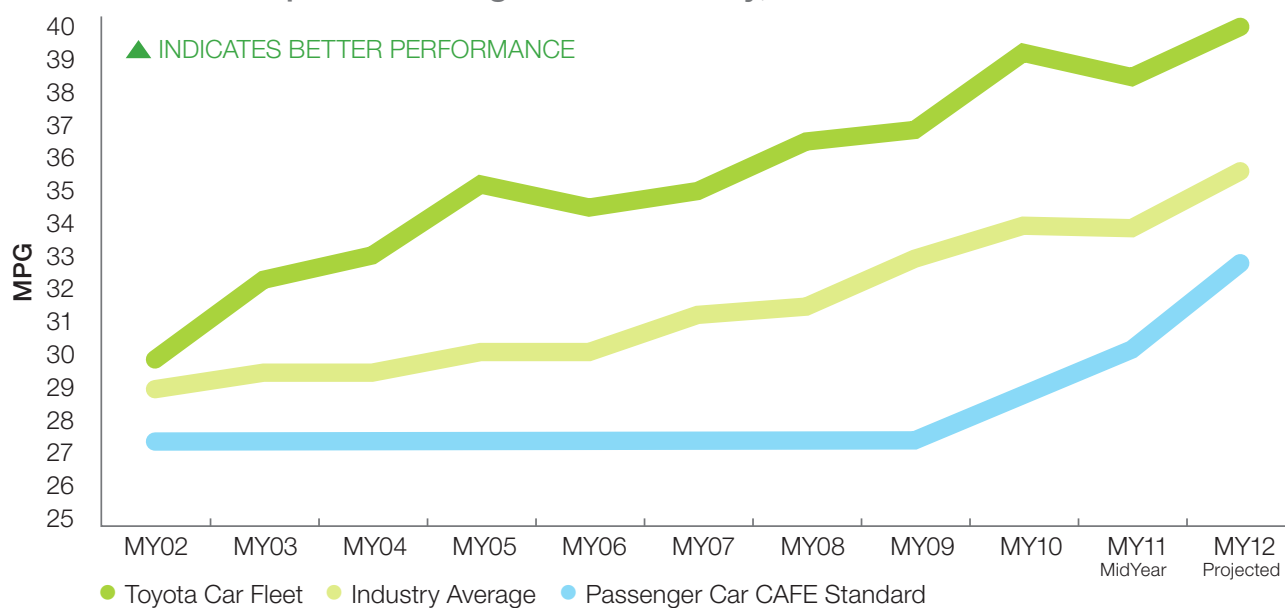

FG6 • U.S. Truck Corporate Average Fuel Economy, or CAFE

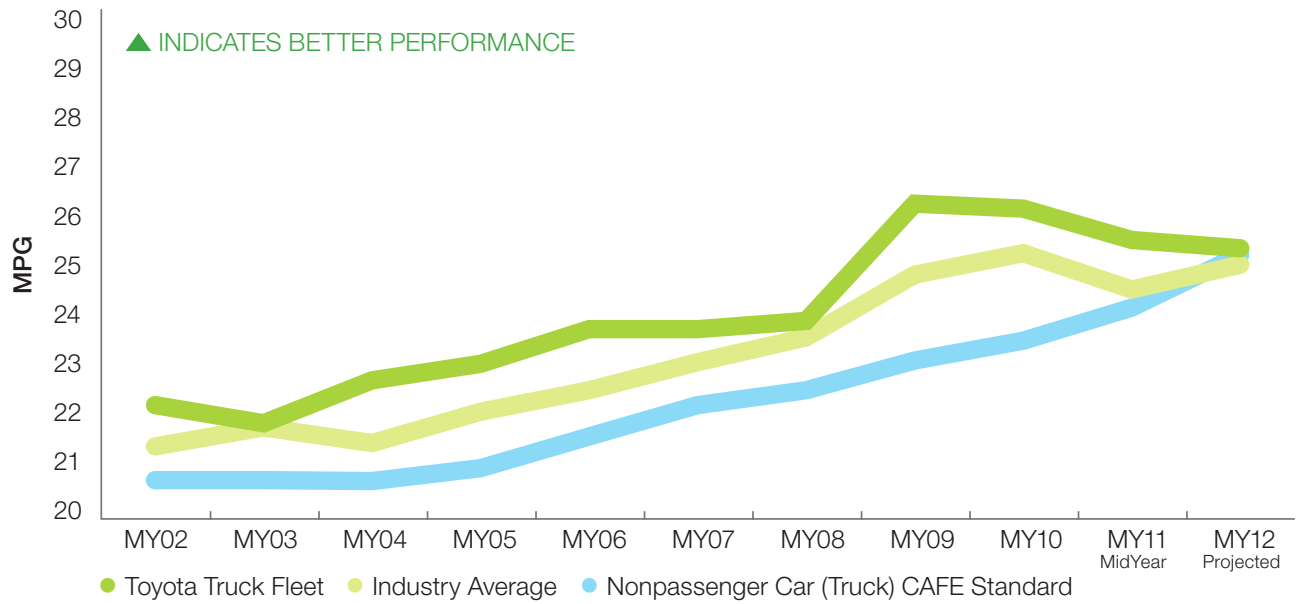

FG6 • Canadian Car Company Average Fuel Consumption, based on GHG Emission Regulation

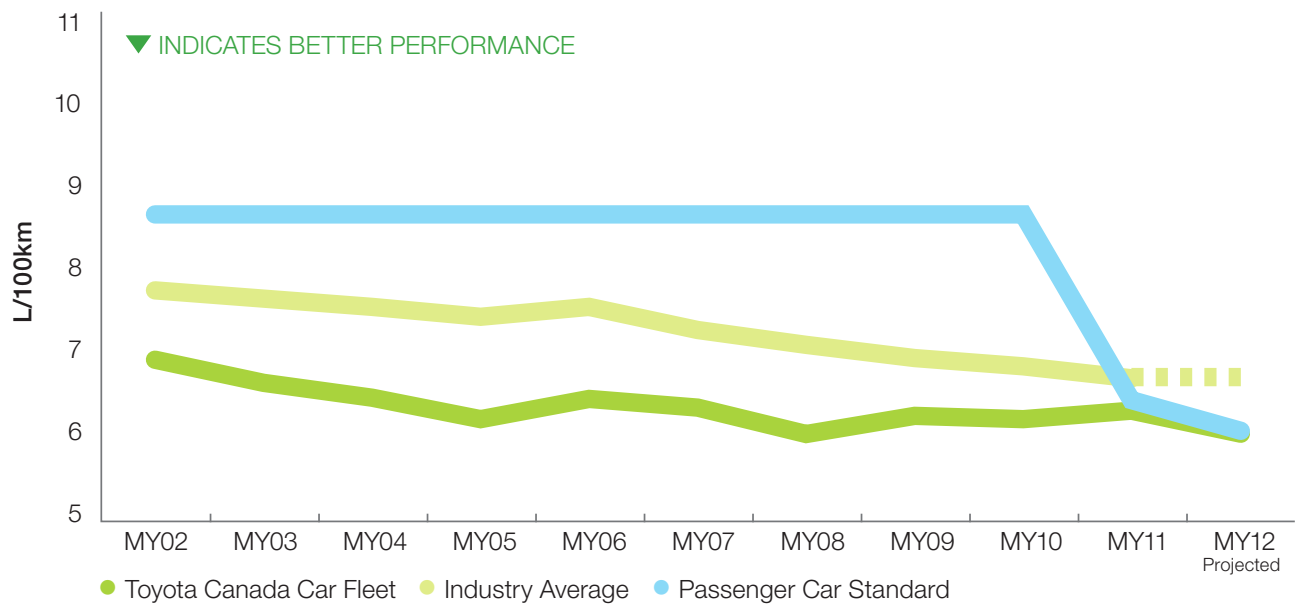

FG6 • Canadian Truck Company Average Fuel Consumption, based on GHG Emission Regulation

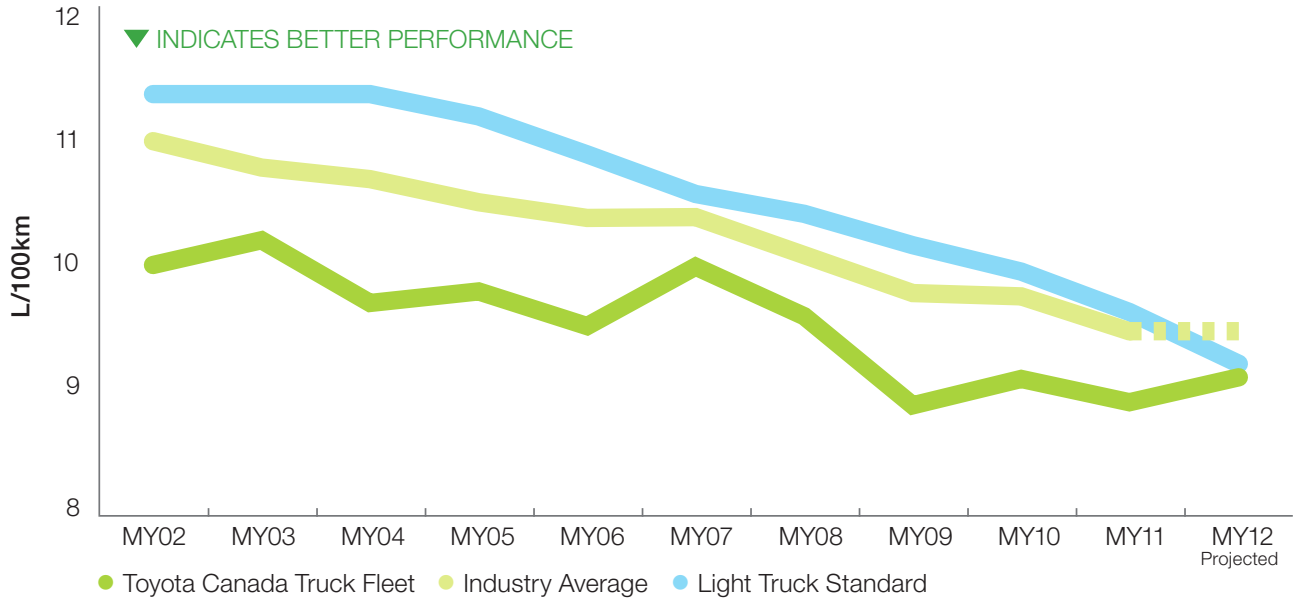

FG7 • Annual CO₂ per Kilometer, Toyota U.S. Fleet

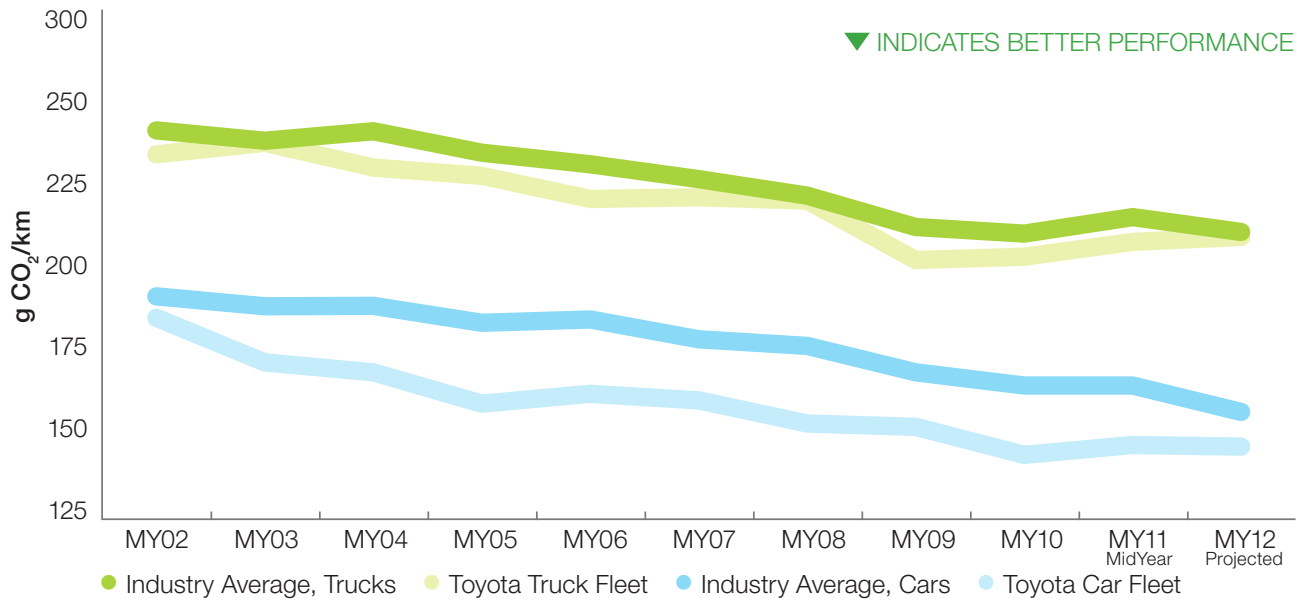

FG7 • Annual CO₂ per Kilometer, Toyota Canadian Fleet

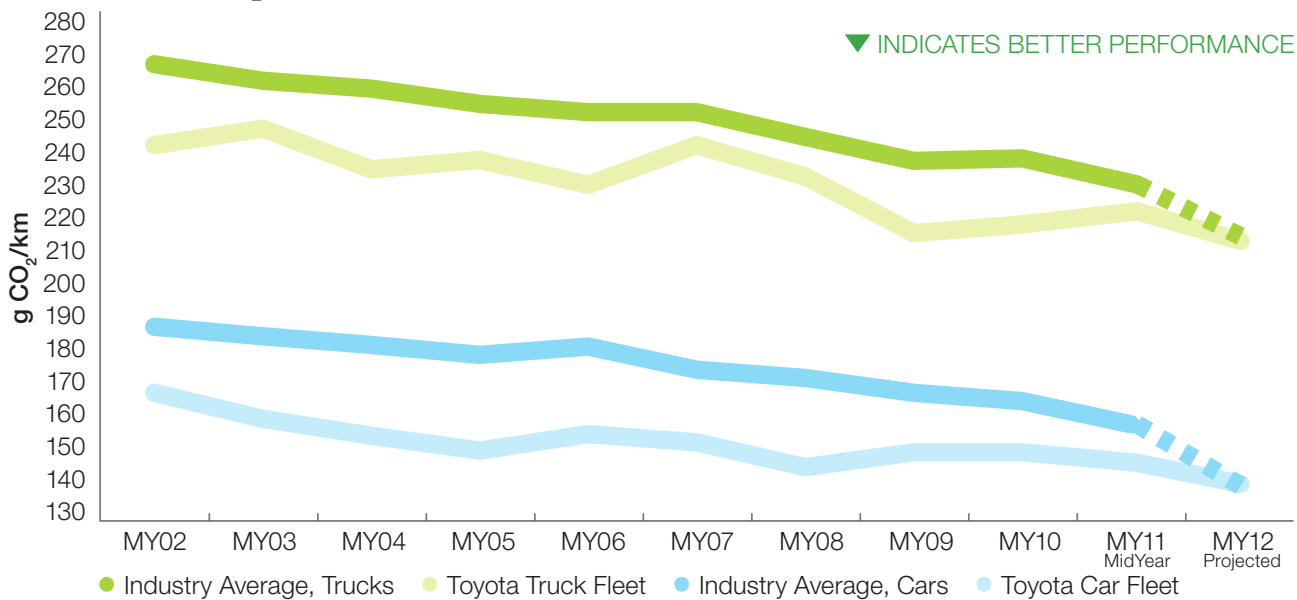

RELATED TOPICS

- For more information on our advanced technology including our hybrid fleet, please visit the [Future Transportation](#) section.
- For information about how we manage CO₂ emissions in operations, please visit [Eco-Efficient Operations/Energy & Greenhouse Gases](#).

CRITERIA POLLUTANT TAILPIPE EMISSIONS

Hydrocarbons, nitrogen oxides (NO_x) and carbon monoxide from vehicle exhaust are linked to various air quality issues, including smog and acid rain, as well as a number of health effects. Limiting these emissions from our vehicles helps to reduce some of the environmental impacts of driving.

The state of California and the U.S. Environmental Protection Agency (EPA) have their own certification programs to categorize vehicles in terms of their level of tailpipe emissions (Canada and the U.S. have equivalent standards). In California, the Low-Emission Vehicle II (LEV II) regulations categorize vehicles as LEV (Low Emission Vehicle), ULEV (Ultra Low Emission Vehicle), SULEV (Super Ultra Low Emission Vehicle), ZEV (Zero Emission Vehicle), or AT-PZEV (Advanced Technology Partial Zero Emission Vehicle).

In 2011, the California LEV II regulations required an auto manufacturer's fleet average to meet an emission standard for non-methane organic gas (NMOG) of 0.035 grams per mile (gpm) for passenger cars and light-duty trucks up to 3,750 pounds, and 0.043 for other light-duty trucks.

In the U.S. and Canada, federal certification programs categorize vehicles into Tier 2 Bins 1 through 8. Lower bin numbers correspond to vehicles with lower tailpipe emissions; Bin 1 is for vehicles with zero tailpipe emissions. The federal programs in both the U.S. and Canada require a manufacturer's fleet average to meet a Tier 2 NOx standard of 0.07 gpm.

We expect the current vehicle emission standards in the United States to change. The state of California is considering amendments to the Low-Emission Vehicle (LEV III) greenhouse gas emissions standards, LEV III criteria pollutant standards and Zero-Emission Vehicle (ZEV) regulations approved by the California Air Resources Board on January 26, 2012. The U.S. EPA is also in the process of developing their next generation of emissions standards (Tier 3). We support extending the One National Program concept developed for greenhouse gas and fuel economy standards to criteria pollutants. This would result in a unified, coordinated approach for regulating criteria emissions where compliance with either agency's requirements is accepted nationwide.

Toyota, along with other auto manufacturers, also supports efforts to harmonize the California LEV III and federal Tier 3 programs. We are working with federal and state agencies through their regulatory processes to help develop rules that are both effective and feasible. We seek to maintain the flexibility to build vehicles based on customer preferences. In setting tailpipe emission regulations, we believe standards should be performance-based and take into account the interaction with other vehicle rules—such as fuel economy/greenhouse gas standards—to ensure that the total package of requirements is workable. As with greenhouse gas emissions, fuels must be considered with vehicle technologies as a holistic system. Reduced sulfur levels in gasoline, already available for the LEV III program, are needed to enable the after-treatment systems being designed for Tier 3 compliance.

PERFORMANCE

Toyota annually complies with the state of California, U.S. and Canadian federal vehicle emissions programs, and we have met the requirements for the 2012 model year.

More information about the emissions performance of Toyota, Lexus and Scion vehicles sold in the United States can be found in EPA's *Green Vehicle Guide*.

FG8 • Toyota and Lexus SULEVs

Specifically for vehicles offered in the 2012 model year, 35 percent of all Toyota, Lexus and Scion cars and 10 percent of trucks are certified to SULEV or better. These vehicles include:

Prius

Prius c

Prius v

Prius Plug-in Hybrid

Camry PZEV

Camry Hybrid

Highlander Hybrid

RAV 4 EV

Lexus RX 450h

Lexus LS 600h

Lexus HS 250h

Lexus CT 200h

*The Lexus GS 450h was not offered in the 2012 model year. The 2013 Lexus GS 450h will be certified to SULEV or better.

**Data is U.S. only and is not sales-weighted.

CHEMICAL MANAGEMENT

Many different types of chemicals are used in the manufacturing of an automobile. These include chemicals used in paint, interior plastics, trims, adhesives and textiles. Chemical management refers to how we manage and minimize the impacts of chemical use to the environment. For years, Toyota's engineers have been incorporating chemical management into the design of vehicles to ensure the utilization of environmentally preferable materials.

Toyota uses the International Material Data System (IMDS) as the primary tool for tracking the chemical composition of parts and accessories. Suppliers are required to enter into IMDS detailed information about the chemical composition of parts and accessories. Through this system, Toyota tracks the use of chemicals on the Global Automotive Declarable Substance List (GADSL), a list developed and maintained by a global automotive stakeholder committee.

Use of IMDS is particularly crucial for ensuring compliance with international recyclability and chemical management laws (such as those in China, Korea, Europe and Japan). Therefore, we adopted IMDS in North America to facilitate tracking and verification of compliance with these laws for vehicles assembled here that will be exported to international markets. For example, Toyota is exporting the Camry and Sienna from North America to South Korea; using IMDS will ensure these vehicles meet South Korea's recyclability laws.

We have completed data collection under IMDS for three vehicles in North America: Camry, Sienna and Venza. The use of IMDS facilitates the effective management of all types of chemicals, including those that are of concern but are not specifically restricted in international recyclability laws. Our recent experience with using IMDS in North America is helping us better understand its benefit for overall chemical management.

DESIGN FOR RECYCLABILITY

In each model redesign or running change, we consider how to use more renewable, recycled and recyclable materials. Toyota Way principles guide these efforts. With the vast number of parts used to make a vehicle, there is trial and error in the process of finding environmentally preferable materials. *Hansei* is the principle that teaches us to evaluate a process thoroughly and ask the five why's in root cause analysis, helping us to judge what works and what doesn't and to evaluate where we can make further improvements.

Over the course of the last several years, Toyota has evaluated numerous materials made from renewable resources to assess their performance, appearance, safety and mass production capability. In addition, the automotive industry is working on finding recyclable and renewable alternatives to petroleum-derived plastics, which reduces reliance on fossil fuels. Toyota is working with SAE's International Green Technology Systems Group on characterizing bio-based materials. This is part of a larger effort by SAE to serve as a guiding body for consensus standards development for environmental sustainability issues in the automotive sector.

We have been using bio-based plastics—plastics derived either wholly or in part from plant materials—in numerous parts and components for over a decade. Toyota hopes that as production volume of such parts increases, their cost will approach that of parts made with traditional fossil fuel-based plastics.

FG9 • Vehicles Containing Bio-based Plastics

MODEL	PART
Prius	Seat cushions, scuff plate, cowl side trim, register blades
Corolla	Seat cushions
Matrix	Seat cushions
RAV4	Seat cushions
Lexus RX 350	Seat cushions
Lexus HS 250h	Luggage trim upholstery, cowl side trim, door scuff plate, tool box area, floor finish plate, seat cushions, package tray
Lexus CT 200h	Luggage compartment liner, carpeting
Camry	Radiator end-tank

FG10 • Lexus HS 250h Eco Plastic Usage Example

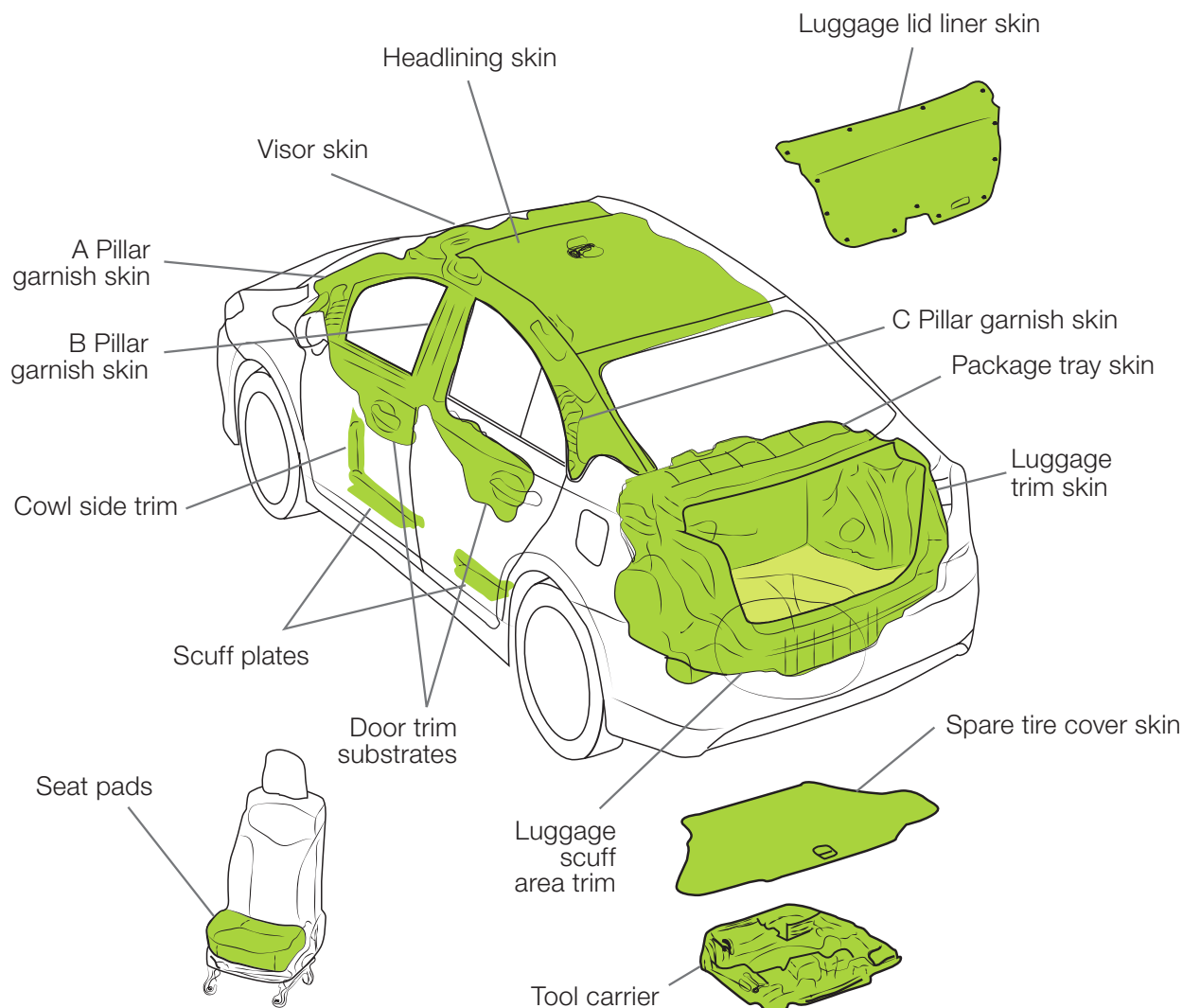

Our bio-based plastics have typically used a polypropylene/polylactic acid (PP/PLA) composite derived from plant material. Toyota has developed a new plant-derived bio-based plastic more suitable for auto interiors than other bio-based plastics. Toyota began using the new material in the luggage compartment liner of the new Lexus CT200h hybrid-electric compact car. This is the world's first use of a bio-based polyethylene terephthalate (PET) resin in the auto industry.

PET, commonly used in plastic water and soft drink bottles, is typically made from 70 percent terephthalate acid and 30 percent monoethylene glycol. In the new bio-based plastic, the latter is replaced with a raw material made from sugar cane. The new material is more heat-resistant and durable and is less susceptible to shrinkage than the corn-based bio-based plastic parts used in some vehicle interiors.

We are currently investigating new materials for fabrics and carpets as well as additional applications of PP/PLA-based and natural fiber-based materials in North American vehicles.

RELATED TOPICS

- For more information on how we manage GHG emissions from vehicle use, please visit [**Green Innovation/Vehicle Efficiency & Emissions/Fuel Economy & GHG Emissions**](#).
- For more information on how we manage GHG emissions in our operations, please visit [**Eco-Efficient Operations/Energy & Greenhouse Gases**](#).
- For more information on our recycling efforts in our operations, please visit [**Eco-Efficient Operations/Waste Minimization**](#).

SUBSTANCES OF CONCERN

Our strategy around managing substances of concern (SOCs) initially focused on four heavy metals known to cause environmental and health effects: hexavalent chrome, mercury, lead and cadmium. In 2004, Toyota made a voluntary commitment in North America to minimize these four heavy metals found in parts and accessories to the *de minimis* levels specified in the European Union's Directive on End-of-Life Vehicles—even though vehicles were not being exported to Europe. After working closely with our suppliers, parts and accessories in North America have not contained hexavalent chrome, mercury, lead or cadmium above levels outlined in the European Union's Directive since 2007.

Our SOC strategy has expanded in recent years to include copper in brake pads and the flame retardant decaBDE. Copper in brake pads is to be phased out by 2025 in alignment with recent legislation in Washington and California. The legislation was created due to concerns about copper found in runoff water. The Alliance of Automobile Manufacturers—of which Toyota is a member—received the prestigious **2011 Edmund G. “Pat” Brown Award** from the California Council for Environmental and Economic Balance (CCEEB) for its work on this legislation. This award is given to a person or organization that exemplifies the spirit of environmental and economic balance. The partnership between the Alliance and environmental groups was commended for working together to find a practical, achievable regulation that both protects water bodies and maintains high standards of vehicle safety. We are working on finding a suitable alternative to the copper used in brake pads.

Another example is decabromodiphenyl ether (decaBDE), a flame retardant used in vehicles. The U.S. EPA and chemical suppliers reached a voluntary agreement to phase out production of decaBDE by December 31, 2013. Toyota has been working with suppliers to develop a replacement for decaBDE that meets the federal motor vehicle safety standard FMVSS302 on flammability of interior materials.

CABIN VOCS

Volatile organic compounds (VOCs) can be emitted from materials in the vehicle interior after manufacturing, commonly recognized as the “new car smell.” These materials include plastics, leather, textiles, glues, sealants and additives. We work with our suppliers to develop alternatives that emit lower levels of VOCs in the vehicle cabin. We have developed new tape systems to reduce toluene emissions. More recently, we have been working with our suppliers on reducing formaldehyde and acetaldehyde that form during leather retanning and finishing.

The Prius Liftback, Prius Plug-in Hybrid, Prius *c*, Prius *v* and Camry Hybrid offer available SofTex-trimmed heated front seats. SofTex material weighs about half as much as genuine leather, and its manufacturing process generates 99 percent fewer VOCs than that of conventional synthetic leather.

Auto manufacturers are working toward one global standard to test emissions of VOCs in vehicle cabins at the component level. In the meantime, a voluntary standard for the full vehicle cabin exists from the Japan Automobile Manufacturers Association (JAMA). Toyota believes the JAMA standard addresses compounds readily found in vehicle cabins. For the 2012 model year, the North American-produced Sienna, Avalon, Corolla, Venza, Highlander, Camry and RAV4 EV conform to this standard.

RELATED TOPICS

- For information on how we manage VOC emissions from painting in our operations, please visit [Eco-Efficient Vehicle/Air Emissions](#).

FUTURE TRANSPORTATION

Someday in the future, we imagine the perfect eco-car. It's what inspires our zero-emissions goal and our drive toward zero impact on the environment. And because of the variety of possible alternative fuel sources, we believe there will be more than one solution. Whether it's electricity, hydrogen or biofuels, we are investing today to advance the vehicles of tomorrow.

Toyota's approach focuses on developing a suite of technologies that can meet the world's mobility needs sustainably and with the flexibility to address the requirements of specific regions or markets. We acknowledge that one technology will not be the "winner" and that a mobility system in New York could look very different from systems in São Paulo, Toronto, London or Shanghai. That's why Toyota is investing in a range of advanced technology vehicles—battery electric, plug-in hybrid and fuel cell, rolling out conventional hybrids across our entire lineup, and improving the efficiency of our conventional engines and powertrains. The timeline below highlights significant milestones in the development of Toyota's advanced technology vehicles.

Our investments in advanced technology address all aspects of the vehicle life cycle. Our commitment to *hansei*—deep periods of reflection and problem solving—have resulted in significant improvements with each generation of our advanced technology vehicles. We continue to reflect and innovate for better fuel efficiency, lower tailpipe emissions, and greater use of renewable and recyclable materials. Below we describe four of our advanced technology vehicles in greater detail: hybrids, plug-in hybrids, electric vehicles and fuel cell hybrids.

FG11 • Advanced Technology Vehicle Milestones

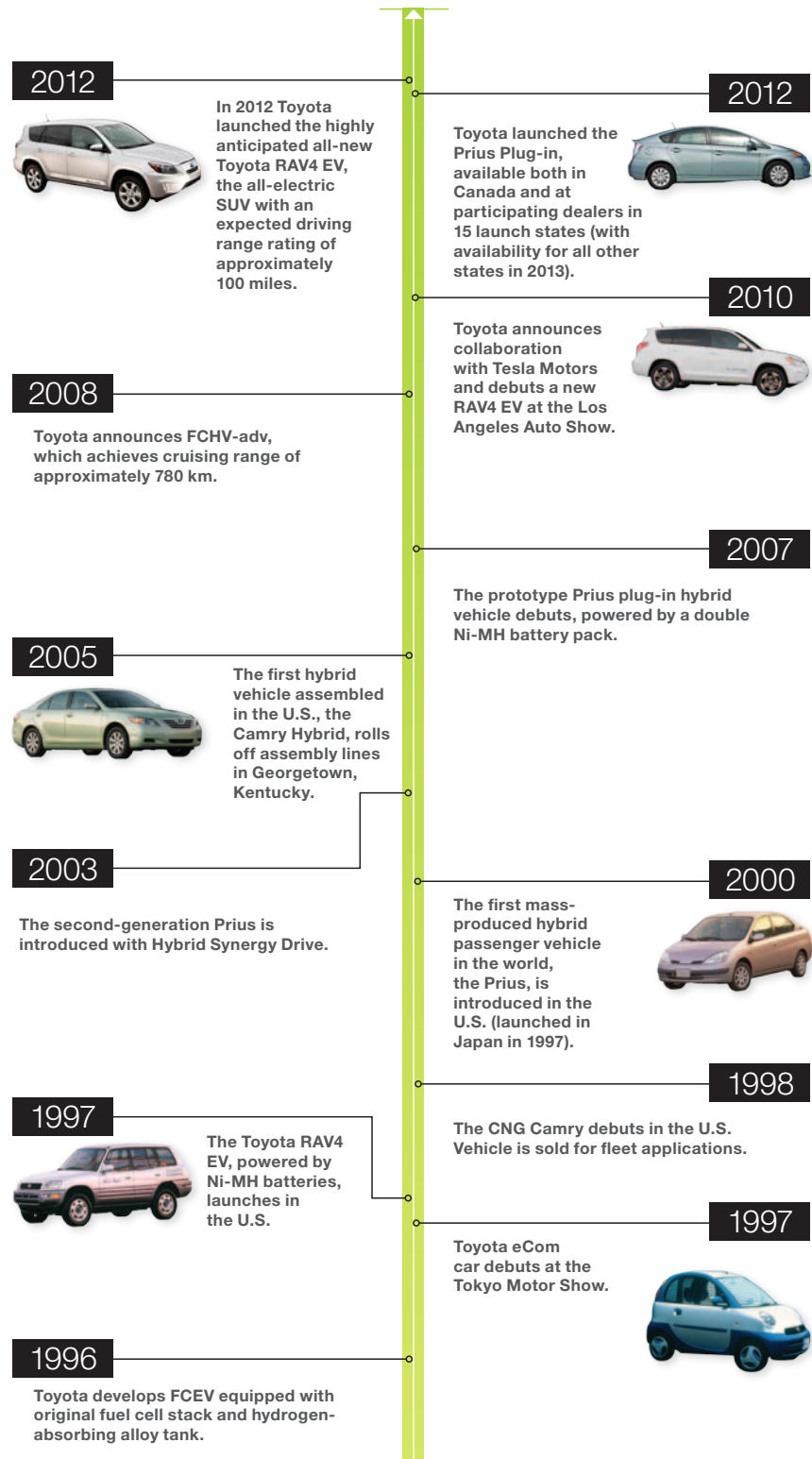

HYBRID VEHICLES

Hybrid technology is the foundation of Toyota's approach to minimizing the environmental impacts of gasoline-powered vehicles. Knowledge gained from hybrid development and deployment is helping Toyota accelerate the introduction of future powertrains that can utilize a wide variety of energy sources and fuels, including hydrogen, biofuel, natural gas and electricity.

Hybrids account for 15 percent of Toyota's global vehicle sales, with over four million sold worldwide (as of June 2012). Over 1.7 million Toyota and Lexus hybrids have been sold in North America to date. In the U.S., the mix of hybrid vehicles for the Lexus brand has increased to 14 percent, double what it was in 2005 when Lexus introduced its first hybrid. In the first half of 2012, Toyota and Lexus hybrid sales accounted for more than 80 percent of Canada's overall hybrid market, and in 2011, nearly one in five Lexus sales was a hybrid.

Total sales of Toyota and Lexus hybrid vehicles globally since 1997 have resulted in a 26 million ton reduction in CO₂ emissions when compared with what would have been emitted by gasoline-powered vehicles of similar size and driving performance, when identically driven and maintained.

FG12 • Hybrid Fleet

The current fleet of Toyota and Lexus hybrids includes:

MODEL	YEAR LAUNCHED
Prius	2000
Highlander Hybrid	2005
Camry Hybrid	2006
Prius v	2011
Prius c	2012
Prius Plug-in Hybrid	2012
Lexus RX 400h/RX 450h	2005
Lexus GS 450h	2006
Lexus LS 600h L	2007
Lexus CT 200h	2011
Lexus ES 300h	2012

*Launch dates refer to North American launches of the first generation of these vehicles.

Toyota and Lexus hybrids have won numerous awards in 2012, including:

- *Kiplinger's Personal Finance* Best New Car Value awards lists the Lexus RX 450h as "**Most Fuel-Efficient**" in the Large and Midsize Crossovers category.
- The American Council for an Energy-Efficient Economy (ACEEE) lists the Lexus CT 200h, Prius and Camry Hybrid as three of the "**Greenest Vehicles of 2012.**"
- Kelley Blue Book's kbb.com lists the Toyota Prius c and the Lexus CT 200h as among its picks for the "**10 Best Green Cars of 2012.**"

SPOTLIGHT: THE PRIUS FAMILY

Toyota's first hybrid—the Prius—accounts for half of all hybrids on the road in North America. The Prius began as an exploration of future technologies, but has evolved into a growing family of vehicles to suit various consumer needs. There is now a hybrid for everyone, including the 2012 Prius *v*, one of Fueleconomy.gov's Top 10 EPA-Rated Fuel Sippers and Canada's most fuel-efficient station wagon—making it 11 straight years that a Prius vehicle has won an **ecoENERGY Award** from Natural Resources Canada.

Toyota hybrid technology has been particularly well-embraced by consumers in the Los Angeles area, where 64 percent of all hybrid vehicles registered are Toyotas. In fact, last year the Prius was the fourth best-selling vehicle in Southern California despite supply issues prompted by the 2011 Tohoku earthquake and tsunami.

Toyota brought the Prius *c*—the latest member of the Prius Family—to market in March 2012. The letter “c” represents “city” in the Prius *c* name. Designed to function as an urban-friendly vehicle with a city fuel economy rating of 53 mpg and a combined rating of 50 mpg, Prius *c* offers the highest city mpg rating of any vehicle without a plug. The all-new Prius *c* joins the third generation Prius Liftback, the versatile new Prius *v* and the Prius Plug-in Hybrid, which also had its North American debut in 2012.

The Prius Family captured 52 percent of the U.S. hybrid market in the first half of 2012. Over 1.2 million Prius Family vehicles have been sold in the U.S. and 2.9 million worldwide (as of June 30, 2012).



The Prius *c* is the latest member of the Prius Family to be brought to market. The Prius Family includes, from left to right: Prius Plug-in Hybrid, Prius *c*, Prius Liftback, and Prius *v*.

PLUG-IN HYBRID VEHICLES

Toyota views the plug-in hybrid vehicle as a pathway to reduce fuel consumption and tailpipe emissions (including CO₂) even beyond a standard gasoline-electric hybrid vehicle. In 2012, we launched the Prius Plug-in, available both in Canada and at participating dealers in 15 launch states (Arizona, California, Connecticut, Hawaii, Maine, Maryland, Massachusetts, New Hampshire, New Jersey, New York, Oregon, Rhode Island, Vermont, Virginia and Washington). Availability is planned for all other states in 2013.

Toyota's Prius Plug-in offers all the advantages and utility of a conventional hybrid vehicle. Its 4.4 kWh lithium-ion battery has more capacity than that of the original Prius and can be charged using a 120V outlet in about three hours (with a dedicated 15 amp circuit). Depending on the driving profile, regular recharging can reduce gasoline consumption by up to one-third over a conventional Prius, which in turn reduces both mobile source greenhouse gas emissions and criteria pollutants.

The 2012 Prius Plug-in can operate on battery power alone at speeds up to 62 miles per hour and is rated by the U.S. EPA with an EV Mode range up to 11 miles. For longer distances and at speeds above 62 miles per hour, the Plug-in automatically changes to hybrid mode and operates like a regular Prius.

The EV mode fuel economy for the Prius Plug-in is rated an estimated 95 mpg (miles per gallon equivalent). In hybrid mode the Prius Plug-in has a combined driving rating of 50 miles per gallon. Total driving range is estimated as high as 540 miles on a single charge and single tank. Drivers who use the vehicle for street driving and frequent short trips while charging regularly will realize the biggest reduction in gasoline usage.

We also revealed the NS4 advanced plug-in hybrid concept vehicle at the 2012 North American International Auto Show in Detroit. The NS4 signifies Toyota's vision for future mobility with a focus on connectivity and the human interface. NS4's advanced powertrain targets a next-generation Hybrid Synergy Drive plug-in system featuring reductions in component size and weight with improved overall fuel economy, better acceleration and longer all-electric range.

PLUG-IN HYBRID VEHICLE BATTERIES

The lithium-ion (Li-ion) batteries powering the Prius Plug-ins are built in conjunction with PEVE (Panasonic EV Energy Company, LTD), a joint venture with Toyota. Toyota designed the Prius Plug-in Hybrid around a battery pack that is smaller than competitive plug-ins or EVs for several reasons. The smaller battery pack serves to boost the vehicle's overall fuel economy. A



We revealed the NS4 advanced plug-in hybrid concept vehicle at the 2012 North American International Auto Show in Detroit in 2012. NS4's advanced powertrain targets a next-generation Hybrid Synergy Drive plug-in system featuring reductions in component size and weight with improved overall fuel economy, better acceleration and longer all-electric range.

smaller battery weighs less, is easier to package in the vehicle, and charges more quickly than a larger one. With shorter charging times, more opportunities to recharge are available in a day. Plus, a smaller battery costs less to build and uses less rare earth elements than a larger one.

The goal was to design a vehicle that fits seamlessly into most people's lives and does not demand sacrifices, yet boosts the overall fuel economy beyond that of a conventional hybrid. Finding the right size battery can yield impressive reductions in gasoline consumption while minimizing greenhouse gas emissions. When balancing the overall environmental impact with the needs of drivers for vehicle range, charge times and fuel consumption, the Toyota Prius Plug-in has a battery that seems "just right."

SPOTLIGHT: GREEN RALLIES

Toyota hybrids are more than ready for the rally world. The *Rallye Vert de Montréal* is the Canadian stop in the world championship of green rallies, as part of the Fédération Internationale de l'Automobile (FIA) Alternative Energies Cup series. The series is an annual competition started in 2007 consisting of 13 rallies around the world. The Montreal rally

challenges environmentally advanced vehicles to be as fuel-efficient as possible. Last fall, a Prius Plug-in placed first in consumption for the second year in a row.

Toyota also placed 21st with a Prius Plug-in at the 2012 *Rallye Monte Carlo des Energies Nouvelles*, the world's oldest and most prestigious green rally. The *Rallye Monte Carlo des Energies Nouvelles*, organized by the Automobile Club of Monaco, attracted 146 competitors who drove 800 kilometers over the course of three days. This was the first event of the year in the FIA Alternative Energies Cup series.

The Toyota Prius Plug-in that placed 21st was driven by Vinh Pham, an Advanced Technology and Powertrain Engineer with Toyota Canada Inc., with seasoned rally racer and Toyota Canada colleague Peter Nytko, Consultant, Technical Services, alongside as navigator. Last fall, the duo teamed together in the Toyota Prius Plug-in to win the 2011 *Rallye Vert de Montréal*, which qualified them for the Monte Carlo event.

“The Toyota Prius Plug-in has proven yet again that its ultra-efficient and powerful powertrain enable us to set a true standard of excellence for electric hybrid vehicles,” said Stephen Beatty, Managing Director and Chief Environmental Officer at Toyota Canada Inc. “Toyota’s plug-in technology provides zero-emission driving balanced with a lighter battery for long distances. We’re very pleased that Vinh and Peter had a chance to showcase Toyota’s superior green technology on such a grand international stage.”

ELECTRIC VEHICLES

Toyota engineers have been studying electric vehicles (EVs) for nearly 40 years. Since the early 1970's, Toyota has made enormous strides in creating a consumer accepted and environmentally preferable electric vehicle. To date, Toyota has



Toyota placed 21st with a Prius Plug-in at the 2012 *Rallye Monte Carlo des Energies Nouvelles*, the world's oldest and most prestigious green rally. The Prius Plug-in was driven by Vinh Pham, an Advanced Technology and Powertrain Engineer with Toyota Canada Inc., with seasoned rally racer and Toyota Canada colleague Peter Nytko, Consultant, Technical Services, alongside as navigator.

developed the TownAce EV (van) and the Crown Majesta EV (sedan) in the Japanese market, the Toyota e-com (a two passenger concept EV), and two generations of the RAV4 EV in the U.S. market. (The 2013 RAV4 EV is being co-developed with Tesla; see below.) Alongside the company's ground-breaking hybrid, plug-in hybrid and fuel cell vehicles, EV technology represents another component of Toyota's long-term vision for future mobility.

Toyota's second-generation RAV4 EV was developed as part of a partnership with Tesla Motors, Inc. Toyota debuted a conversion RAV4 EV at the Los Angeles Auto Show in November 2010. Conversion RAV4 EVs were built for a demonstration and evaluation program that ran through 2011. The EV demonstration program aimed to educate the public about electric vehicle technology and promote the development of electric vehicle charging infrastructure. The customer experience has been a major focus from the beginning. Toyota's end goal for the RAV4 EV was a vehicle with drivability characteristics as close to the conventional V6 RAV4 as possible.

The electric RAV4 is initially being offered for sale late in the summer of 2012 exclusively in California, focusing on major metropolitan markets. Toyota expects to build and sell 2,600 RAV4 EVs over the next three years. The RAV4 EV will be built at Toyota's manufacturing plant in Woodstock, Ontario, while Tesla will build and supply the battery as well as other related powertrain parts and components.

The RAV4 EV has a 41.8 kWh lithium-ion battery pack that not only gives the vehicle exceptional range, it also powers the vehicle from 0-60 mph in just seven seconds in Sport mode. Due largely to the battery pack, the RAV4 EV weighs 470 pounds more than its V6 counterpart. But Toyota's engineers placed that weight low and toward the center of the vehicle to achieve an overall center of gravity similar to that of a sedan.

When plugged into a Level 2, 40-amp, 9.6-kW output charger, the RAV4 EV's battery pack can be fully replenished in as little as five hours. The vehicle comes equipped with a 120v charging cable for use when Level 2 charging is not available.

In preparation for the launch of Toyota's electric vehicles in the United States, including the second-generation RAV4 EV and Scion iQ EV, an open-access electric vehicle charging station opened at Toyota of Hollywood in 2011. Additional stations have been installed at Toyota of Santa Monica, Lexus of Santa Monica and at Fisker Santa Monica. All of these dealerships are owned by the same dealer group. The dealership charging stations are open to customers of all vehicle types with an electric charge port.

EV limitations, such as recharging time and limited range, continue to be barriers for consumers' willingness to consider the technology. While some consumers are willing to accept these limitations for the vehicle's smooth electric drivetrain and zero tailpipe emissions, this is only a small percentage of the market. EVs will be one option in our portfolio of advanced technologies, but not the solution for every customer.

HYDROGEN FUEL CELL HYBRID VEHICLES

Toyota believes that hydrogen holds great potential as a clean, renewable fuel. Our goal is to bring a Fuel Cell Hybrid Vehicle (FCHV) to market by 2015. To get there, Toyota researchers are continuing to develop the technology and are currently testing about 100 vehicles powered by hydrogen fuel cells.

During the 2012 North American International Auto Show, the FCV-R concept debuted. This concept model is a highly practical fuel cell vehicle (FCV). With the fuel cell unit located beneath the specially designed body, the vehicle can accommodate up to four passengers and boasts impressive luggage space. The fuel cell stack, with its 70 MPa high-pressure hydrogen tank, provides a cruising distance of approximately 435 miles (700 kilometers).

Toyota's FCHVs are powered by fuel cells that generate electricity from hydrogen. Hydrogen gas is fed into the fuel cell stack where it is combined with oxygen from air. The electricity produced by this chemical reaction is used to power the vehicle's electric motor and charge the battery. A fuel cell vehicle emits only water vapor; the exhaust contains no particulate matter, hydrocarbons or other pollutants.

In 2002, Toyota began a lease program for FCHVs in the U.S. and Japan with universities and



We debuted the FCV-r concept at the North American International Auto Show in 2012. With the fuel cell located beneath the specially designed body, the vehicle can accommodate up to four passengers and boasts impressive luggage space. The fuel cell stack provides a cruising distance of approximately 435 miles (700 kilometers).

corporate customers. Toyota has gathered millions of miles of on-the-road information about our FCHVs. For example, we carried out a road test in September 2007 along the Alaska-Canadian (ALCAN) Highway. Driving 2,300 miles (3,700 kilometers) between Fairbanks, Alaska, and Vancouver, British Columbia, the FCHV proved its ability to maintain consistent performance under demanding conditions.

Since the 2002 introduction of the first-generation FCHV, Toyota engineers have continued to improve the FCHV's range, durability and efficiency through advances in the fuel cell stack and the high-pressure hydrogen storage system, while achieving significant cost reductions in materials and manufacturing. The latest FCHV iteration, the FCHV-advanced (FCHV-adv), was introduced in 2008 and boasts an estimated range increase of more than 150 percent over the first-generation FCHV. The FCHV-adv fuel cell system features four compressed hydrogen

fuel tanks, an electric motor, a nickel-metal hydride battery and a power control unit.

Toyota began delivering our latest-generation FCHV-adv to limited test customers in late 2008. To demonstrate the in-use driving range of this vehicle, Toyota conducted a driving range and fuel economy evaluation with engineers from the National Renewable Energy Laboratory and the Savannah River National Laboratory. Two FCHV-adv vehicles were instrumented, filled with hydrogen fuel and driven during a variety of driving conditions on a weekday from Torrance, California, to San Diego, then to Santa Monica and back. Both FCHVs completed the 332-mile (534-kilometer) trip with enough hydrogen left in the tanks to keep going an estimated 100 miles (160 kilometers). Fuel economy on the journey was approximately 68 miles per kilogram of hydrogen (109 kilometers per kilogram). (A kilogram of hydrogen is roughly the same energy equivalent as a gallon of gasoline.)

Toyota has deployed more than 100 FCHV-adv vehicles with universities, private companies and government agencies in both California and the New York metro area as part of a national demonstration program. Customers are using the vehicles for everyday tasks—commuting, driving around town for work, running errands—and are providing valuable feedback about their experiences. We placed 10 FCHV-adv vehicles in the fall of 2010 to support the new SunHydro solar-powered hydrogen fueling station located at Proton Energy Systems’ headquarters in Wallingford, Connecticut. SunHydro is leading the development of hydrogen fueling stations along the East Coast that will make it possible to drive a fuel cell vehicle from Maine to Florida. When completed, the series of SunHydro stations will be the world’s first privately-funded network of hydrogen fueling stations.

The demonstration program aims to increase awareness of fuel cell technology and spur development of much-needed infrastructure prior to the planned market introduction of the FCHV in 2015. Additional regions and partners will be added to the demonstration program as new hydrogen stations come online.

In the summer of 2012, Toyota began construction on the expansion of Toyota’s Technical Training Center in Glen Burnie, Maryland, which serves Toyota’s Central Atlantic region. When the expansion is complete in 2013, this facility will be Toyota’s first technical training center in the United States with the majority of the required infrastructure established to train on future FCHVs. Currently, Toyota’s FCHV-adv vehicles throughout the United States are serviced by engineering staff out of our engineering and development technical centers. When we bring a sedan-based FCHV to market in 2015, we will need to ensure dealership service center technicians are trained to work on this technology. With this center’s expansion, we are getting a jump on the 2015 date by integrating special features that will allow an easy transition to hydrogen vehicle service.

RELATED TOPIC:

- Watch a short video about TOYOTA’S HYDOGEN FUEL CELL VEHICLES in the real world.

PARTNERSHIPS: ADVANCING HYDROGEN INFRASTRUCTURE

While fuel cell technology has advanced significantly over the last few years, fueling

infrastructure must be in place for hydrogen-powered fuel cell vehicles to become a reality for consumers. By 2015, Japan has committed to building 100 hydrogen refueling stations, while Germany has committed to building 50. Hydrogen

infrastructure is also growing in the United States, but additional stations are needed before mass market introduction in 2015.

Currently, there are only about 56 hydrogen stations in the United States, many with limited public access. This includes the first hydrogen fueling station fed directly from an active industrial hydrogen pipeline, which opened in 2011 in Torrance, California. Located adjacent to Toyota's U.S. sales and marketing headquarters campus, the station is a collaborative effort between Toyota, Air Products and Shell, and received funding assistance from the South Coast Air Quality Management District and the U.S. Department of Energy. Shell operates the facility, and Air Products provides on-site equipment, station maintenance and hydrogen gas through a pipeline from its plants in Wilmington and Carson, California. The station is used by Toyota and other manufacturers to fuel hydrogen fuel cell vehicles.

The University of California Irvine (UC Irvine) is collaborating with six automakers, including Toyota, to develop a comprehensive hydrogen station plan for California designed to meet the coverage required for initial commercial deployment of FCHVs. UC Irvine is using STREET (Spatially & Temporally Resolved Energy & Environment Tool), a systematic and highly detailed land-use based methodology that establishes and evaluates fuel infrastructure scenarios. UC Irvine is targeting three regions in Southern California: Santa Monica/West Los Angeles, Torrance and Beach Cities, and southern and coastal Orange County. With advanced planning, UC Irvine estimates that to service the initial market for fuel cell vehicles, coverage comparable to the existing gas station network would require between 11 and 14 percent the number of hydrogen stations. In order to launch the FCHV to the commercial market, this analysis identifies 68 strategically placed stations required to be operational by 2015.

ALTERNATIVE TRANSPORTATION FUELS

The availability and diversity of alternative transportation fuels plays a key role in helping countries realize their energy security and greenhouse gas reduction goals. The Energy Information Agency projects that the continued high price of

FG13 • Hydrogen Stations, Greater Los Angeles Area



petroleum will motivate some level of switching to alternative fuels, resulting in growth of renewable fuels at a faster rate than petroleum-based fuels. Alternatives to traditional gasoline and diesel fuels, such as ethanol, biodiesel, natural gas and electricity, are already in the marketplace in many parts of the world. Others, like hydrogen, cellulosic ethanol, other biohydrocarbons and various synthetic fuels, are on the horizon.

To help stakeholders better understand the benefits and challenges of fuels diversity, Toyota is participating in a National Petroleum Council study that will result in a report on the prospects of future transportation fuels through 2035, with views to 2050, for auto, truck, air, rail and waterborne transport. The study, requested by the Secretary of the Department of Energy, has four main objectives:

- Address fuel demand, supply, infrastructure and technology in the context of U.S. objectives to protect the environment, promote economic growth and competitiveness, and support energy security.
- Describe accelerated technology pathways to improved fuel efficiency, reduced environmental impact and deployment of alternative fuels at scale.
- Deliver insights into potential policy options and investments that industry and government can take to accelerate the acceptance of alternative fuels, engines and vehicles.
- Describe actions that industry and government can take to stimulate the technological advances and market conditions needed to reduce life-cycle GHG emissions in the U.S. transportation sector by 50% by 2050 relative to 2005 levels, while enhancing the nation's energy security and economic prosperity.

Although beneficial in many ways, fuels diversity challenges global auto manufacturers to design and build competitive vehicles with vastly different powertrains and operating characteristics. A number of Toyota's advanced technology vehicles are designed to use alternative fuels such as electricity and hydrogen.

But the current lack of infrastructure for some of these fuels, particularly hydrogen for fuel cell hybrid vehicles and electric charging stations for electric vehicles, is one of the greatest obstacles to commercialization. Without convenient places to recharge or refuel, the mainstream consumer will be less willing to adopt these advanced technologies.

FG14 • Energy Sources for Toyota's Advanced Technology Vehicles

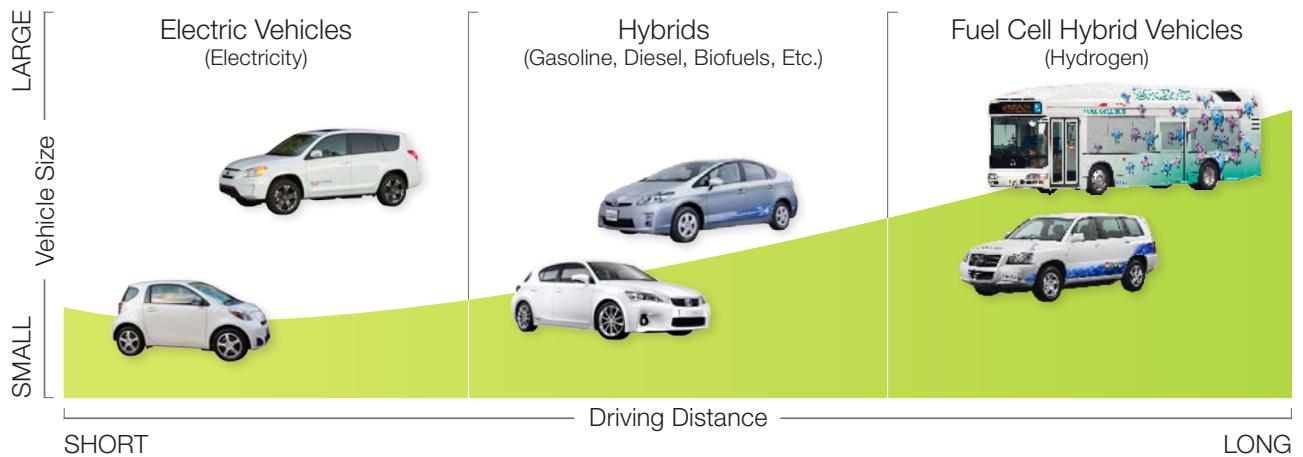

The vehicles shown from left to right are: Scion iQ EV, RAV4 EV, Lexus CT 200h, Prius, FCHV-adv and a fuel cell hybrid bus.

Through the California Fuel Cell Partnership (CaFCP), the California Plug-In Electric Vehicle Collaborative, and the Fuel Cell and Hydrogen Energy Association (FCHEA), Toyota is working with government agencies—including the U.S. Department of Energy—other auto manufacturers, utilities and other key stakeholders to support the development of necessary infrastructure for these vehicles. Our demonstration programs in North America play a key role in supporting infrastructure development by educating the public and stimulating the development of infrastructure to support deployment of our advanced technology vehicles.

TOYOTA

2012

NORTH AMERICAN **ENVIRONMENTAL REPORT**

ECO- EFFICIENT OPERATIONS

- > AIR EMISSIONS
- > BIODIVERSITY
- > ENERGY & GREENHOUSE GASES
- > GREEN BUILDING
- > WASTE MINIMIZATION
- > WATER

Eco-Efficient Operations is a chapter in the Toyota 2012 North American Environmental Report. Read the entire report online at Toyotaenvironmental.com or scan the QR code to access the report with your mobile device.





To watch a short video about TOYOTA'S process for CONVERTING WASTE into garden fresh produce on your mobile device, scan the QR code below.



> ECO-EFFICIENT OPERATIONS

Toyota has 14 manufacturing locations across North America where team members produce 12 vehicles:

the Lexus RX 350 and the Toyota Avalon, Camry, Corolla, Highlander, Matrix, RAV4, Sienna, Sequoia, Tacoma, Tundra and Venza. Our newest plant, where we build the Corolla, opened in Blue Springs, Mississippi, in November 2011. We also have 41 sales and logistics locations across North America, including sales offices, port facilities on both coasts, and vehicle and parts distribution centers that serve both the manufacturing plants and our network of 1,850 dealerships.

In the process of manufacturing and transporting over one million vehicles each year in North America, Toyota uses raw materials, energy and water; we manage large tracts of land where our manufacturing facilities are located; and we occupy offices in a number of different cities. All of these activities result in impacts to the environment. These impacts increase when our production levels increase, in particular when we bring a new plant or a new shop online, as we did in Blue Springs.

The Japanese concept of *monozukuri* means more than manufacturing; it also means building people. We want to develop team members who take ownership in their jobs, share the aspirations of Toyota's Global Vision, and work for their communities and the world at large. Such individuals must take part in *hansei*, the Japanese concept for reflection. *Hansei* is both an intellectual and emotional experience. It requires an individual to recognize a problem and be open to both positive and negative feedback. It also requires and empowers the individual to voluntarily take personal responsibility for fixing the problem and to commit to a specific course of action to improve the process so that the problem does not happen again.

Hansei has helped us find ways to improve our environmental performance, even when the economy was in a downturn. We cannot allow what we have learned to be lost, and the process of reflection encouraged by the Toyota Way ensures that we learn from both our successes and our failures.

We strive to reduce all of our environmental impacts. Toyota Motor Corporation (TMC), our parent company in Japan, has identified emissions of volatile organic compounds, energy consumption, waste generation, water use and biodiversity as key areas of focus for Toyota locations around the world. We have established targets across our various functions to address these issues. In North America, we have also identified green buildings as an area of importance. Our approach, as well as our performance, in all of these areas are described in the following sections.

REFLECTION

The Japanese word *hansei*, translated loosely as reflection, is what happens when one of our employees stops to examine a completed project. *Hansei* is both an intellectual and emotional introspection. The employee must recognize the gap between the current situation and the ideal, take responsibility for finding solutions, and commit to a course of action. When a project finishes at Toyota, we use *hansei* to evaluate what went well and what did not. We then methodically try to preserve what went well and create countermeasures for what did not. These lessons are incorporated into the standard process so that when we repeat it, we improve over the last time. Finally, we share these insights with our colleagues so that they can learn as well, in a process we call *yokoten*.

AIR EMISSIONS

Air pollutants such as particulate matter, nitrogen oxides and volatile organic compounds (VOCs) react with sunlight to form smog. Smog has been linked to a number of health issues and is particularly prevalent in dense urban areas with heavy traffic, industrial activity and sunny, warm climates.

Toyota's painting operations generate the majority of our VOC emissions. We are working hard to minimize our emissions.

We have a North American Manufacturing VOC Working Group that studies aspects of the vehicle body painting process to find ways to reduce VOC emissions. *Hansei*, or reflection, is a process used by the working group to review progress and identify the remaining gap between the target and actual results, and it is this group that takes responsibility for examining the issue and finding solutions. Group members review painting operations as a whole, as well as the components of the process to find big and small opportunities for improvement, or *kaizen*. We benefit from sharing best practices and transfer of knowledge, or *yokoten*, from one plant to the next.

TARGET AND PERFORMANCE

Target: Maintain VOCs from the body paint process at manufacturing plants at 13.9 g/m² in FY2012 (achieved)

Toyota's North American plants measure grams VOCs emitted per square meter of vehicle surface area coated (g/m²). Our target in fiscal year 2012 was to maintain VOC emissions at an average 13.9 g/m² for all North American plants. We met this target and achieved average VOC emissions of 13.7 g/m².

There are many factors to consider when setting VOC targets, including fluctuations in production volumes, model change activity and the introduction of different painting methods. In addition, our data gathering methods have improved over the last couple of years. Although we have been successful in meeting, and even exceeding our VOC target, we are working hard to assure that our annual results are consistent and that we can continue to find ways to reduce our emissions.

Over the last decade we have reduced VOC emissions by 61 percent, from 35.0 to 13.7 g/m². This achievement is the result of the combined efforts of Toyota team members at the plants and at the headquarters facilities in Japan and the United States. Team members at the plants have made continuous improvements to equipment work practices (e.g. purging lines, cleaning equipment, reducing overspray) to reduce chemical usage and resulting VOC emissions. Team members at the headquarters facilities have improved designs to equipment such as paint cartridge robots. The use of cartridge robots has resulted in the elimination of paint lines, which reduces the amount of wasted paint and the purge necessary to clean the paint lines and allows for more precise painting. Recently, Toyota has been moving paint applicators (spray guns) closer to the car to further reduce overspray.

FG15 • VOC Emissions

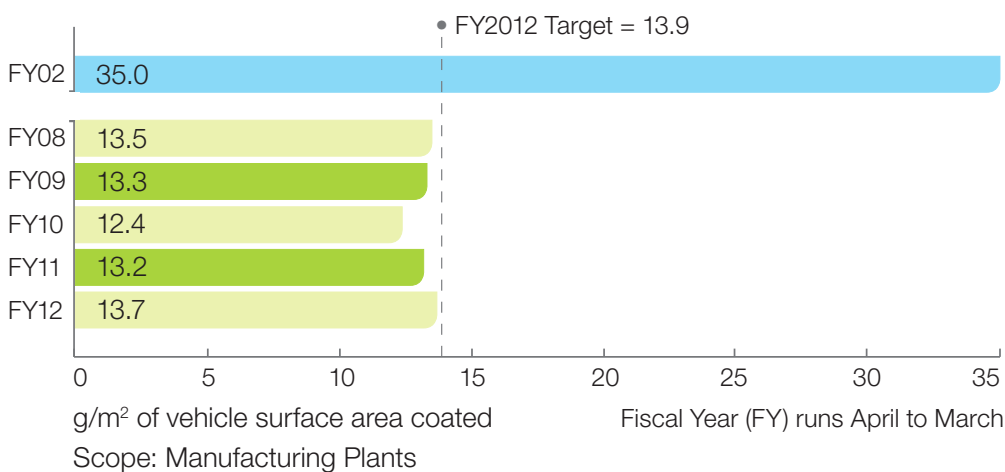

61%
REDUCTION
SINCE FY02

RELATED TOPICS

- For information about how we manage VOCs in vehicle cabins, please visit [**Green Innovation/Chemical Management/Substances of Concern**](#).

BIODIVERSITY

Biodiversity refers to the variety of animal and plant life on Earth. The diversity of living organisms, and the habitats in which they live, are crucial for the functioning of ecosystems and the resources and benefits they provide—fresh water, fertile soils, medicines, shelter and recreation, to name a few examples. Because the well-being of species living within an ecosystem are so interlinked, human activities can have great influence—both positive and negative—on biodiversity.

Since the company's founding, Toyota has believed in the pursuit of growth that is in harmony with nature. This philosophy is in our [**Earth Charter**](#) and is evident in the attention we pay to minimizing our environmental impacts. Our approach to protecting biodiversity centers on the habitats that exist within the 21,000 acres of land owned by our North American manufacturing and R&D facilities in the United States, Canada and Mexico.

SPOTLIGHT: TOYOTA'S NATURE TRAILS

Our plant in Georgetown, Kentucky, is located on 1,300 acres in Scott County. This is Toyota's largest assembly facility outside of Japan. The plant has the capacity to assemble over 500,000 Camry, Camry Hybrid, Avalon and Venza vehicles and manufacture 600,000 engines each year. In the "backyard" of this facility is the Environmental Education Center | Nature Trail, developed to promote environmental education through hands-on learning opportunities and ultimately to demonstrate how manufacturing can co-exist with nature. This mission is shared with the 40,000 visitors that tour the plant each year, including thousands of students from across Kentucky and neighboring states, and even from other parts of the world.



In the “backyard” of Toyota’s assembly plant in Georgetown, Kentucky, lies the Environmental Education Center | Nature Trail, visited by over 40,000 people each year from across Kentucky and neighboring states, and even from other parts of the world.

The Georgetown plant began its nature program in 2006 by setting aside 50 acres of wetlands, prairies and woodlands. The nature trail opened a year later to provide visitors an opportunity to learn about Kentucky’s natural treasures and how Toyota works hard to protect them. Today, the plant’s wildlife team actively manages 62 acres of habitat and has 340 acres of unmanaged habitat available for wildlife on the site.

The ultimate goal is to return a portion of the set-aside land to its native habitat. Kentucky cane, one of North America’s few native bamboo species, has been planted along the trail and is maintained by clearing weeds from the area to reduce competition. Once established, the cane will provide a healthy home for migratory birds and small mammals.

Two endangered plants—Short’s goldenrod and Running Buffalo Clover—can also be found on the property. In 2009, 44 Short’s goldenrods were planted, nurtured in a greenhouse, and moved to the nature trail. These plants are highlighted during educational tours. In 2011, the U.S. Fish & Wildlife Service provided several endangered Running Buffalo Clover plants. Ground was carefully selected and prepared, as the plants require a specific combination of sun and shade to flourish.

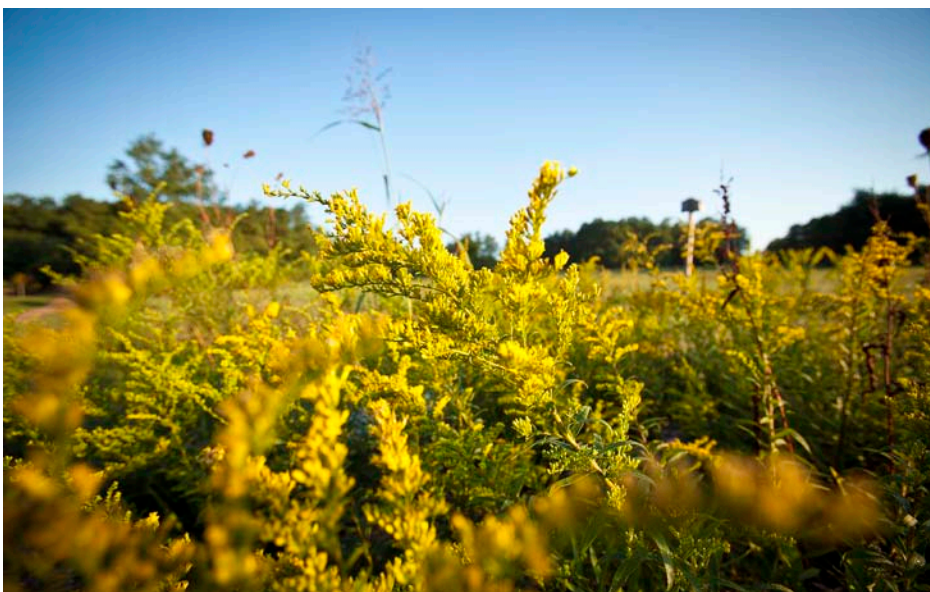

Short’s goldenrod is one of two endangered plants that can be found along the nature trail at Toyota’s Georgetown, Kentucky, plant.

Toyota's partnership with the U.S. Fish & Wildlife Service has been instrumental in the recovery and restoration of these species. "We have been working with Toyota through our Partners for Fish and Wildlife Program for a few years now, and it's a partnership that we greatly enjoy," said J. Brent Harrel, Kentucky Private Lands Coordinator for the U.S. Fish & Wildlife Service/Kentucky (ES) Field Office. "The Partners for Fish and Wildlife Program is a voluntary private lands program to conduct habitat restoration. We work with the Kentucky Department of Fish and Wildlife Resources and Toyota on many things. It is important to form these partnerships and work together to do great things for the environment and for our children. It is our hope that we can do many more things with Toyota in this realm in the future."

Team members at the Georgetown plant have found creative ways to share all they've learned on the nature trail about ecosystems, biodiversity and endangered species. About 2,000 students visit the Environmental Education Center | Nature Trail each year. Between the tours of the plant and the use of the environmental education center, students, scout groups and the community are shown Toyota's vision of how industry and the environment can coexist.

The Georgetown plant partnered with Mary June Brunner, a volunteer at the Environmental Education Center and professor at Midway College in Lexington, Kentucky; Bluegrass PRIDE (which stands for "Personal Responsibility In a Desirable Environment"); and teachers from local high schools to create a Web-based curriculum for fourth through 12th grades. This curriculum is used with students touring the plant to help them better understand Toyota's corporate commitment to the environment. The curriculum focuses on the same environmental issues highlighted along the nature trail: water quality and conservation, solid waste, energy and air quality.

Bluegrass PRIDE has been providing environmental education since 2001 for 18 counties in the Central Kentucky area. According to PRIDE's Deputy Director, Maxine Rudder, "Toyota has had a tremendous impact on increasing awareness of the importance of environmental stewardship in communities far beyond Scott County, Kentucky."

During Earth Week in 2012, Toyota's Georgetown plant celebrated the fifth anniversary of the Environmental Education Center | Nature Trail. Six students from Liberty Elementary School in Fayette County attended the anniversary celebration to deliver a presentation about the water quality studies they had participated in at the plant during the 2010-11 school year.

Also as part of the celebration, 75 second-grade students from Northern Elementary, a local Scott County school, visited the nature trail and participated in an Environmental Field Day. Activities were led by guest organizations such as the Louisville Zoo, Kentucky Department of Fish and Wildlife Resources and the University of Kentucky Cooperative Extension, among others.

"Everyone had a great day," said Tara Krebs, second-grade teacher at Northern. "It was wonderful to see the students, adults and parents discover a different aspect of Toyota. Not everyone knows that the nature trail is here. Toyota is so involved in our community and they put such time and thought into making this land beautiful. This is a wonderful outreach opportunity. We wish we could go every year!"

These activities have had a positive impact on school children and the local community. Through the process of *hansei*, or reflection, we have identified what works and what could be improved at the nature trail at our Georgetown plant, and are looking to apply *yokoten* to transfer best practices to other Toyota locations. In addition to the Georgetown plant, we have nature trails to enhance habitat and foster education among team members and surrounding communities at Toyota's North American manufacturing headquarters in Erlanger, Kentucky, and at our assembly plant in Princeton, Indiana.

Toyota's manufacturing headquarters in Erlanger, Kentucky, recently built its own nature trail and celebrated the grand opening during Earth Week 2012. Team members are working on posting educational signs and installing bird boxes, a pollinator garden, a butterfly pond and a wildflower meadow—all ideas that used *yokoten* to transfer knowledge from the Georgetown plant in true Toyota fashion.

Toyota's assembly plant in Princeton, Indiana, has also developed a nature trail. In addition, they have planted thousands of trees and plan to reforest much of the site with native species. Tree planting activities are taking place in five phases, at the end of which 200,000 trees will have been planted on the site.

Toyota's manufacturing facilities in Cambridge and Woodstock, Ontario, are in the process of constructing nature trails, as well as pollinator gardens—a natural area that is inhabited by native plants and species to increase the productivity of the area. Pollinator gardens provide a safe place for species to flourish, especially animal pollinators like butterflies. This idea was also shared as a *yokoten* from the Georgetown plant, who won a **Pollinator Protection Award** in 2011 from the Wildlife Habitat Council and North American Pollinator Protection Campaign (NAPPC).



Toyota's manufacturing plant in Woodstock, Ontario, is in the process of constructing a nature trail and a pollinator garden. Pollinator gardens provide a safe place for species to flourish, especially animal pollinators like butterflies.

This award is due in part to the efforts of Frances Jansen, a team member at the Georgetown plant who wrote to Kentucky's Governor, Steve Beshear, to suggest he proclaim the third week in June as "Pollinator Week." Pollinator Week has grown to be an international celebration of the valuable ecosystem services provided by bees, birds, butterflies, bats and beetles. Kentucky is now one of 27 states with this event.

RELATED TOPICS

- For more information on environmental education initiatives in the communities where we live and work, please visit [**Strengthening Communities/Environmental Education**](#).

PARTNERSHIP: WILDLIFE HABITAT COUNCIL

Our partnership with the Wildlife Habitat Council (WHC) began at our Georgetown plant. In 2008, it became the first Toyota plant to obtain certification to the Wildlife Habitat Council's *Wildlife at Work* and *Corporate Lands for Learning* programs. In 2010, the plant was one of three sites nominated as "Corporate Habitat of the Year" by WHC, and recently, the plant achieved a three-year recertification.

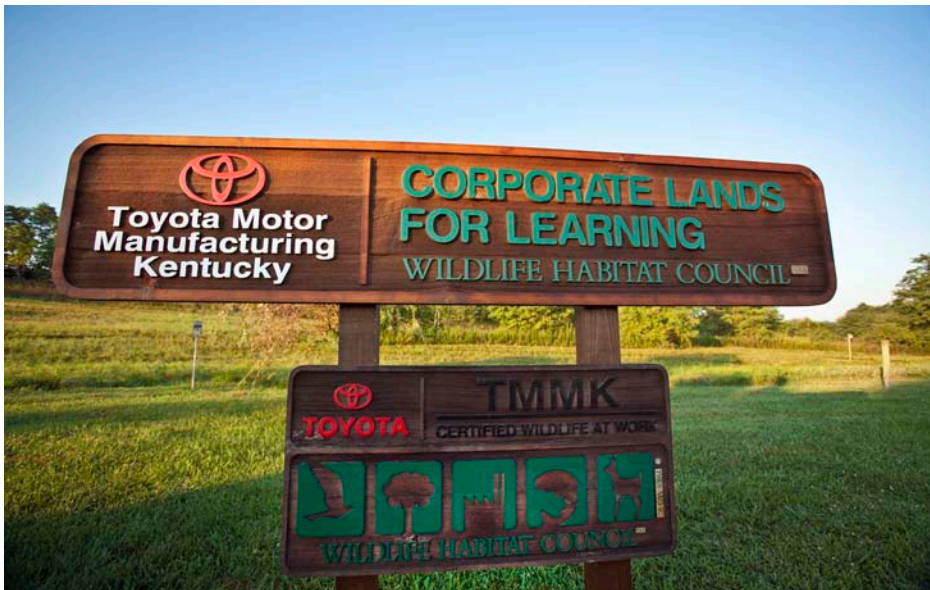

In 2008, our plant in Georgetown, Kentucky, became Toyota's first plant to obtain certification to the Wildlife Habitat Council's Wildlife at Work and Corporate Lands for Learning programs. Toyota is working with the Wildlife Habitat Council on identifying a common habitat enhancement theme for all of our North American manufacturing plants.

The Wildlife Habitat Council's Corporate Wildlife Habitat Certification/International Accreditation Program recognizes commendable wildlife habitat management and environmental education programs at individual sites. Certification criteria are stringent. Sites must demonstrate that programs have been active for at least one year with a management plan that lists goals, objectives, prescriptions and complete documentation of all programs. The Certification Review Committee, a panel of WHC wildlife biologists and staff, reviews the materials for certification eligibility and recognizes deserving projects under an appropriate category.

The Wildlife Habitat Council is a nonprofit group of corporations, conservation organizations and individuals dedicated to restoring and enhancing wildlife habitat. WHC works with corporations and other landowners to create tailored voluntary wildlife habitat enhancement and conservation education programs on corporate facilities and in the communities where they operate. We recently decided to work with WHC on identifying a common habitat enhancement theme for our North American manufacturing plants. With our plants working towards a common goal of preserving and protecting the environment for "all" of Toyota's neighbors—human as well as plants, animals and the land itself—our efforts will have the greatest impact.

ENERGY & GREENHOUSE GASES

Energy, greenhouse gases and renewable energy—these three issues are closely related. The consumption of energy is a major contributor to greenhouse gas (GHG) emissions. Energy efficiency measures, along with the use of renewable energy such as wind and solar, reduce the GHG emissions associated with energy consumption. We discuss each issue below.

ENERGY CONSUMPTION

Most of the electricity consumed in North America is generated from fossil fuels, such as coal and natural gas. These resources are non-renewable, meaning they cannot be naturally replenished for consumption. All forms of electricity generation have some level of environmental impact. Burning fossil fuels to generate power can lead to air emissions, impact water bodies, produce waste and disturb large areas of land if mining is involved to obtain natural resources. These impacts, combined with the rising cost of energy, make energy efficiency a high priority for companies in all industry sectors.

Energy consumption refers to the amount of electricity and natural gas used to power our facilities. As a large energy consumer, Toyota is constantly looking for ways to be more efficient in our operations, both to minimize the impact our energy use has on the environment and to reduce cost. In North America, Toyota's manufacturing plants are our largest energy consumers, and they have set a strategic goal to become the leader in energy performance in North America. To accomplish this goal, we are investigating new technologies and identifying *kaizen* opportunities to deliver incremental improvements, then using the concept of *yokoten* to transfer lessons learned and best practices from one facility to another.

We use other concepts of the Toyota Way, including *hansei*, or reflection, to help us identify successes and failures, as well as new opportunities. We also rely on the creativity of our employees, a Toyota Way principle known as *souikufu*. Bethany Giordano, Facilities Water and Energy Specialist at our plant in Georgetown, Kentucky, has been running an annual energy reduction contest for the last few years. The contest, this year called the "Green Machine," encourages team members to find innovative ways to reduce energy consumption. Ten shops—two paint shops, two assembly areas, stamping, bodyweld, plastics, powertrain, quality control and die manufacturing—participated in fiscal year 2012. This year's "Green Machine" champion was the Powertrain shop; they reduced the number and size of motors on their coolant systems and installed higher-efficiency motors. In all, the competition resulted in energy savings of over 26,600 MMBtus and \$14,400 in reduced energy costs during fiscal year 2012. (MMBtu means Million British Thermal Units and is a way of combining electricity and natural gas into a single measure of energy consumption.)

We are proud to report that Bethany Giordano was nominated by her Toyota peers and selected by the Association of Energy Engineers for the **2012 Young Professional Energy Engineer of the Year Award** (Region III). Bethany is a member of the Association of Energy Engineers (AEE), Southwest Ohio Chapter. AEE is a professional organization of energy engineers, energy managers, energy technicians and energy consultants. AEE members operate and manage power facilities, implement energy efficiency and renewable energy technologies, and educate customers and employers about ways to reduce energy usage, costs and pollution.

Bethany has been a Specialist at Toyota's Georgetown, Kentucky, plant for 10 years. She was the Volunteer of the Year at the Georgetown plant and is involved in the Girls in Engineering program that introduces female students to engineering at an early age.

Bethany is also a Certified Energy Manager (C.E.M.); she co-leads and participates in the plant-wide Energy Management Organization. She provides engineering support to plant shops on energy reduction activities, engineering problem solving analysis, and countermeasures for Utility Area Systems including compressed air, instrument air and chilled water systems. She analyzes electrical and mechanical systems to develop methods for improving dependability, efficiency, operating practices and maintenance costs. She works with management and skilled team members to develop countermeasures and set direction.

Toyota is proud of Bethany's accomplishments and her recognition of those accomplishments by the AEE.



Bethany Giordano, Facilities Water and Energy Specialist at our plant in Georgetown, Kentucky, was selected by the Association of Energy Engineers for the 2012 Young Professional Energy Engineer of the Year Award (Region III). Bethany participates in the plant-wide Energy Management Organization and is involved in the Girls in Engineering program.

ENERGY STAR® AWARDS

In 2012, Toyota's North American manufacturing division (Toyota Motor Engineering & Manufacturing North America) received an **ENERGY STAR® Sustained Excellence award** for the eighth consecutive year. The U.S. Environmental Protection Agency (EPA) selects organizations for this award that have exhibited exceptional leadership year after year in the ENERGY STAR program. Toyota's North American manufacturing division was recognized for its role in:

- Decreasing absolute energy use by nine percent.
- Influencing the company's supply chain by continuing to train Tier 1 suppliers to conduct internal plant energy assessments known as Treasure Hunts. Thirty-three companies benefitted from the training in 2011.
- Supporting the ENERGY STAR Auto Focus Group actively for over 10 years.
- Conducting new research for expanded benchmarking of assembly and powertrain plants.
- Completing the analysis on the reduction of air intake to ovens in paint shops with a pilot installation planned for 2012. A preliminary analysis across North America indicates a savings potential of 95,300 MMBtus, equivalent to 28 million kilowatt-hours or 31,000 tons of CO₂ emissions, when implemented in all paint shops.
- Motivating energy savings through monthly energy contests and the annual Toyota Summer and Winter Shutdown Energy Reduction Challenges.

The U.S. EPA began Industrial Round Tables in 2002. In 2003, Toyota was a leader in approaching the ENERGY STAR program to form the ENERGY STAR Auto Focus Group. The focus group brings together energy experts from all North American automotive manufacturers to compare best practices and discuss technological developments for energy reduction.

The Auto Focus Group developed the first industrial Energy Performance Indicator (EPI) for assembly plants, defined as welding, painting and assembly operations located in the same location. The EPI normalizes energy consumption for vehicle size and location to show how efficiently a specific plant is performing. Plants that perform in the upper quartile (top 25 percent) based on the EPI are recipients of the ENERGY STAR Plant performance award.

Toyota's Georgetown plant has been a recipient of the **ENERGY STAR Plant award** every year since the award began. (Note: There is a small discontinuity in awards due to a request from ENERGY STAR to align awards with calendar years). Within the Georgetown plant, there are two assembly lines. Line 2 has won six consecutive awards—the most recent in 2012—and Line 1 has won five. During this time frame, the Georgetown plant has used energy management techniques such as adjusting start and stop times, making minor equipment modifications, and implementing major *kaizens* to reduce total consumption. Since beginning its energy management program, the plant has reduced its energy consumption per vehicle from over nine MMBtus per vehicle to less than six MMBtus per vehicle.

Eight Toyota plants also achieved the **ENERGY STAR Challenge for Industry**, designed to recognize individual industrial sites. Any manufacturing site whose company is an ENERGY STAR partner is eligible to enroll in the Challenge for Industry. Sites take the challenge by signing up to improve their energy efficiency by 10 percent in five years. These eight Toyota sites have achieved the challenge for an average energy intensity reduction of nearly 24 percent:

- Bodine Aluminum in St. Louis, Missouri
- Bodine Aluminum in Jackson, Tennessee
- Toyota's plant in Buffalo, West Virginia
- Toyota's plant in Huntsville, Alabama
- Toyota's plant in Princeton, Indiana
- Toyota's plant in San Antonio, Texas
- Toyota's plant in Woodstock, Ontario
- Toyota's plant in Cambridge, Ontario

Ten plants are currently taking the challenge, working to achieve a 10 percent reduction. They demonstrate our commitment to continuous improvement.

Our efforts to reduce energy consumption continue in our sales and distribution operations. In the United States, six of these facilities have been recognized with **ENERGY STAR awards**:

- Headquarters building in California
- Toyota Customer Services building in California
- Toyota Financial Services building in California
- Toyota Plaza in California
- Gramercy Plaza in California
- North American Parts Center Kentucky

The award for the North American Parts Center Kentucky required advanced collaboration with EPA program administrators to overcome the challenges in applying the program criteria to a large warehouse facility. Through this partnership, the ENERGY STAR program gained experience that helped them apply the program to more varied facility types.

STRATEGY: ADIABATIC HUMIDIFICATION

Adiabatic humidification refers to humidifying the air without the need for additional heat. In fiscal year 2012, when the North America-wide adiabatic humidification project began, we predicted the project would reduce energy consumption by more than 550,000 MMBtus—equivalent to 161 million kilowatt-hours or 211,000 tons of CO₂, and a little more than five percent of total consumption from our manufacturing division.

Paint shops represent over 60 percent of the energy consumption for Toyota's North American manufacturing division. Air for the spray painting process must be maintained at specific temperature and humidity levels to ensure paint adhesion and quality. The standard paint process consumes natural gas, steam and chilled water to reach these set points. Winter temperatures require large amounts of energy, first to heat the air and then to add moisture.

Hansei, or reflection, helped us better understand the humidification process. Previously, we used pre-heat, wet water walls and steam humidification to get moisture content to the correct point, and then we fine-tuned temperature using chilled water coils and steam reheat. Steam was used at two points—once to humidify and once to reheat—to reach the final set point. Steam is an inherently inefficient means of heating process systems. The overall efficiency of steam delivery from a central boiler plant to the point of use often hovers around a mere 50 percent. So we targeted the elimination of centralized steam plants to improve overall energy efficiency.

High-pressure water atomization, using pumps to pressurize the water to over 900 psi and special nozzles to generate extremely fine misting, can raise this system efficiency to over 90 percent. The gas burner on the paint air supply house combined with the high-pressure water atomization system allows Toyota to create necessary humidity control inside the air supply house, which significantly improves efficiency. The increased energy efficiency is seen throughout the year. The adiabatic humidification also provides cooling in the summer, which saves significant amounts of chilled water.



High-pressure misting uses pumps to pressurize water to over 900 psi and special nozzles to generate extremely fine misting. This helps to improve the energy efficiency of the humidification systems used in our paint shops.



Another improvement was to utilize “window” control instead of traditional set point control. The window is created based on the wide range of temperature and humidity conditions acceptable for applying paint. By using a larger window, energy use is reduced significantly.

Our plant in Georgetown, Kentucky, has completed installation of the adiabatic system in Plant 1 and the Plastics shop, and will complete the Paint 2 shop during fiscal year 2013. Also during fiscal year 2013, we will complete systems at the paint shops at our plants in Woodstock, Ontario, and Princeton, Indiana; and we will complete a pilot at our plant in San Antonio, Texas. Remaining plants and plastics shops will be completed during fiscal years 2014 and 2015.

TARGET AND PERFORMANCE

2012 Target: Reduce energy consumption at manufacturing plants to 7.28 MMBtus per vehicle (achieved)

Toyota's North American manufacturing facilities set a target to improve energy efficiency to 7.28 MMBtus per vehicle produced. We achieved this target, thanks to *kaizens* implemented at a number of our plants. For example:

- Our plant in Delta, British Columbia, is responsible for die design, development and manufacturing of aluminum wheel products for Toyota. Last year, team members recognized that the more energy-efficient equipment installed in a recent expansion was not being fully utilized. The heat treat oven and paint booth were not running at their full capacity. By reorganizing and adding casting equipment, and relocating and adding machining capacity, the equipment and processes are now fully utilized. Older, less efficient equipment was shut down. The entire project led to an absolute energy savings of 590,000 kilowatt-hours.
- Toyota's plant in Huntsville, Alabama, piloted the use of ultra constant discharge (UCD) lighting in team member parking lots in 2011. By replacing high pressure sodium (HPS) lighting with UCD lighting, energy use was reduced by 69 percent, saving the plant over 40,400 kilowatt-hours per year. The life expectancy of UCD lighting is 20,000 hours, compared to only 12,000 for HPS. Because of the UCD lighting's energy efficiency and better light quality, the remaining HPS lighting on the plant's campus will be replaced during fiscal year 2013. The plant in Alabama is the first Toyota facility to use UCD lighting. Now that the performance of UCD lighting has been confirmed, we will begin *yokoten* and share this knowledge with other Toyota facilities.
- In July of 2010, Bodine Aluminum was contacted by the Missouri Department of Natural Resources (MDNR) about participating in the "Energize Missouri Industries" program. This program was designed to provide companies with the opportunity to realize measurable energy savings while reducing energy costs and improving market competitiveness. Matching grants were available for up to 50 percent of the cost of certain projects through funding received by the MDNR from the American Recovery and Reinvestment Act of 2009. Out of the 196 companies who applied, Bodine Aluminum was one of only 45 companies to receive a grant.

The company was selected to replace its current thermal oxidizer with a regenerative thermal oxidizer (RTO). The original thermal oxidizer was connected to the sand reclamation system and was used to control emissions of volatile organic compounds (VOCs) from the sand/resin mixing operations. The unit was 90 percent efficient for the destruction of VOCs, but only 50 to 75 percent energy efficient. The unit consumed approximately 1.3 MMBTUs of natural gas per hour of operation. The replacement RTO reduces VOC emissions by 98 percent and is 97 percent energy efficient. It consumes 0.36 MMBTUs of natural gas per hour of operation, a significant decrease from the previous system that amounts to a 73 percent reduction in energy use. Other benefits include waste reduction due to increased sand life, lower potential for odor due to improved VOC destruction, and lower maintenance costs.

In addition to *kaizens* identified and implemented, we continue to evaluate additional improvement opportunities for the future. During fiscal year 2012, we completed an evaluation of energy reduction opportunities implemented in the paint shops in fiscal year 2010. This evaluation provided internal benchmarking, identified differences in equipment efficiency and measured actual energy efficiency against ideal performance.

To date, the energy evaluation has identified reduction opportunities totaling over 643,500 MMBtus, equivalent to 188 million kilowatt-hours—approximately six percent of annual energy consumption in Toyota's North American manufacturing division. From this evaluation, Toyota identified two specific reduction opportunities—oven air flow reduction and pre-heating RTO combustion air—that we plan to implement in all North American assembly plants during fiscal years 2013 through 2015.

FG16 • Energy Consumption

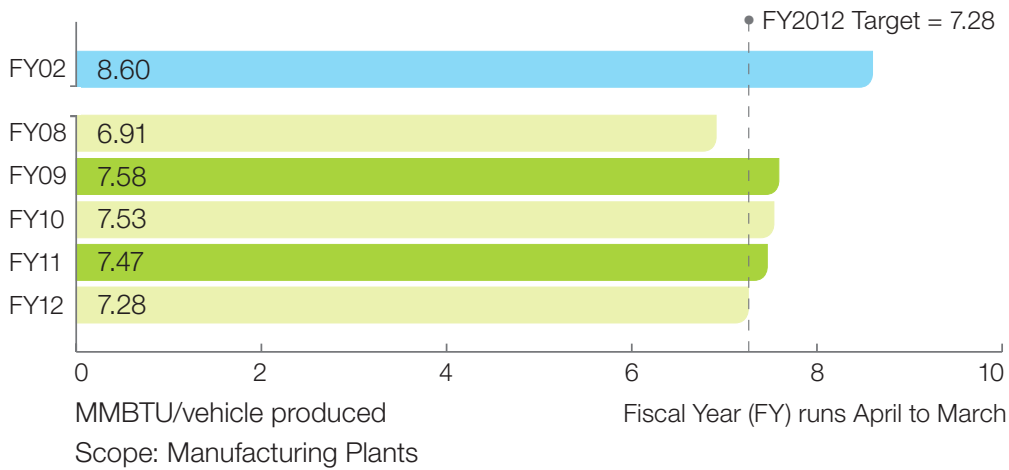

15%
REDUCTION
SINCE FY02

SPOTLIGHT: SAVINGS FROM LIGHTING RETROFITS

Toyota consumes over one billion kilowatt-hours of electricity each year, some of which lights our facilities. Toyota's largest manufacturing facility in North America opened in Georgetown, Kentucky, in 1986. With over 6,200 team members assembling Camry, Camry Hybrid, Avalon and Venza, Toyota is the third largest employer in the commonwealth of Kentucky. The Georgetown plant consumes a lot of electricity—approximately 375 million kilowatt-hours—to assemble 500,000 vehicles and manufacture 600,000 engines each year.

Lighting technology has changed significantly in the 25 years since this facility was constructed. In 2003, we started investigating the replacement of old lighting fixtures. The metal halide lights were inefficient and took over 10 minutes to warm up, which meant they were rarely turned off. The goals of the investigation were to find energy savings, improve light levels and obtain team member buy-in. As part of this process Toyota worked with several suppliers to develop a fixture that met our needs.

In 2005, pilot lighting was installed at four of our manufacturing plants to highlight the improved lighting and energy reduction capabilities of high-bay fluorescent lighting. At the same time, Toyota team members participated in training at the GE Lighting Institute in Cleveland, Ohio, and evaluated a new high-bay fluorescent fixture that GE Lighting had developed. Using Toyota Way concepts, including *hansei*, Toyota team members identified more than 25 ideas for *kaizen* to improve the quality of the fixture and lower its cost. Following training, team members from Toyota's Georgetown plant led investigations into developing a new high-bay fixture.

One of the difficulties was finding a design with an occupancy detector that could detect movement 25 feet away—the distance between the light and the assembly floor. “We worked for almost three years with a lighting company and a fixture company to develop the fixture that we needed for our application,” said David Absher, Manager, Environmental Engineering and Energy Management at the plant. “Both companies took input from us and incorporated it into the final design. The result was the introduction of new products that Toyota and other manufacturers can use in high-bay lighting applications that are very energy-efficient.”



David Absher, Manager of Environmental Engineering and Energy Management at our Georgetown, Kentucky, plant, holds one of the new, more efficient T-8 high-output fluorescent lamps used for high-bay lighting at a number of our North American manufacturing plants. David was part of the team that worked with suppliers over the course of several years to develop this fixture.

We ultimately installed T-8 high-output fluorescent lamps, which are used at a number of our facilities in North America. Each time we relamp, we replace 1,000 to 3,000 fixtures (1,000 fixtures have about 6,000 lamps).

T-8 high-output fluorescent lamps became Toyota's North American manufacturing standard, meaning they are used any time a plant undertakes a relamping project. We also made a decision to eliminate the practice of providing process light from overhead. Lights are now installed where they are needed rather than to light the entire building.

The West Virginia plant was the last plant to upgrade high-bay lighting. The plant had 2,000 high-efficiency fluorescent lights installed with motion sensors to ensure lights are off during weekends and between shifts. Each light saves 158 kilowatt-hours per month; changing 2,000 lights at this one location is the equivalent of taking 280 houses off the power grid.

The time and effort to find and develop the right light fixture and lamp were well spent: Across North America, lighting retrofits at Toyota's manufacturing plants have resulted in annual savings of 17 million kilowatt-hours and 10,000 tons of greenhouse gas emissions, enough to power 1,500 households.

In addition to lighting retrofits at our manufacturing facilities, we have also completed lighting retrofits at some of our North American sales and logistics sites. By replacing T-12 lamps with T-8 lamps in our sales headquarters office in Toronto and at the Toronto parts distribution center offices, we are saving about 420,000 kilowatt-hours annually. We plan to replace lights in the Toronto parts distribution center warehouse in 2012. In addition, all U.S. parts distribution facilities are in the process of upgrading to advanced lighting systems using high-output T-5 lamps with motion and daylight sensors.

PARTNERSHIP: MEXICO'S ENVIRONMENTAL LEADERSHIP PROGRAM FOR COMPETITIVENESS

In 2011, Mexico's Secretary of Environment and Natural Resources invited leading companies to join its "Environmental Leadership Program for Competitiveness," a nationwide effort to encourage companies to reduce their environmental footprint. Toyota's plant in Tijuana, Mexico, was selected to be a regional group leader in Baja California and has been working with 11 companies on projects that reduce energy consumption, greenhouse gas emissions and water use. This is an innovative way to share best practices and encourage companies to work together for the benefit of environmental protection.

Toyota's Tijuana plant implemented three projects during fiscal year 2012 that reduced annual electricity consumption by one million kilowatt-hours and natural gas usage by 16,000 MMBtus, and avoided almost 2,000 tons of carbon dioxide emissions. Under Toyota's leadership, the 11 Baja California companies identified 19 projects that resulted in:

- Water savings of 36,000 cubic meters (9.5 million gallons) per year.
- Energy savings of 5.4 million kilowatt-hours per year.
- Avoided emissions of 3,700 tons CO₂ per year.

In addition, Toyota's Tijuana plant received a **Clean Industry Certificate** from Mexico's Federal Agency for Environmental Protection (PROFEPA) for the second time in a row. PROFEPA awards Clean Industry Certificates to companies implementing hazardous waste management systems, wastewater and water recycling programs, and environmental security measures that allow them to comply with standards through PROFEPA's voluntary audit program. Each certificate is valid for two years.



Toyota's plant in Baja California, Mexico, received a Clean Industry Certificate from Mexico's Federal Agency for Environmental Protection (PROFEPA) for the second time in a row. PROFEPA awards these certificates to companies that implement hazardous waste management systems, wastewater and water recycling programs, and environmental security measures.

RELATED TOPICS

- Environmentally beneficial efforts in our paint shops focus on reducing emissions of volatile organic compounds (VOCs). The thermal oxidizers used to destroy VOCs consume large amounts of energy. To learn more about VOC reduction activities, please visit [Eco-Efficient Operations/Air Emissions](#).
- For more information on how we work with our suppliers to help them find ways to reduce their energy use, please visit [Supporting Our Business Partners/Suppliers](#).

GREENHOUSE GAS EMISSIONS

Greenhouse gases (GHGs) include carbon dioxide (CO₂), methane (CH₄), nitrous oxide (N₂O), hydrofluorocarbons (HFCs) such as refrigerants, perfluorocarbons (PFCs), and sulfur hexafluoride (SF₆). These gases (along with water vapor) trap heat in the Earth's atmosphere and cause the greenhouse effect. This is a natural occurrence that helps regulate the temperature of our planet. But over the last 20 years, scientists have raised concerns that human activities are causing levels of greenhouse gases to increase at a faster rate than at any other time in human history. Predictions vary, but an increase in the greenhouse effect could cause global temperatures to rise, leading to long-term impacts to the environment and human health.

Toyota is concerned about the possible impacts of climate change and is committed globally to a "low-carbon society." Energy use at Toyota's assembly plants is our main source of GHG emissions. As described in the [Energy Consumption](#) section, our plants carefully manage energy use and have found innovative ways to reduce consumption and corresponding GHG emissions. We are also looking into [renewable energy](#) as a means of reducing our carbon footprint.

RELATED TOPICS

- Please see [Green Innovation/Vehicle Efficiency & Emissions/Fuel Economy & GHG Emissions](#) for how we address GHG emissions from our vehicles.

TARGET AND PERFORMANCE

2012 Target: Reduce GHG emissions at manufacturing plants to 0.80 metric tons CO₂ per vehicle (achieved)

This year, we are reporting our GHG data in a different manner. In prior years, we reported GHG emissions from Toyota's manufacturing facilities in the United States only, as we were participating in the Department of Energy's Climate VISION program. This program has ended.

Our fiscal year 2012 target was to reduce GHG emissions from energy consumption at our North American manufacturing plants to 0.80 metric tons CO₂ per vehicle produced. This target is in line with our [energy consumption target](#). We surpassed this target and achieved 0.78 metric tons CO₂ per vehicle produced.

Many of the *kaizens* discussed in the *Energy Consumption* section contributed to our success. Energy management activities either implemented or in the implementation phase are predicted to further reduce Toyota's manufacturing CO₂ footprint by more than 380,000 tons per year.

FG17 • Manufacturing CO₂ Emissions

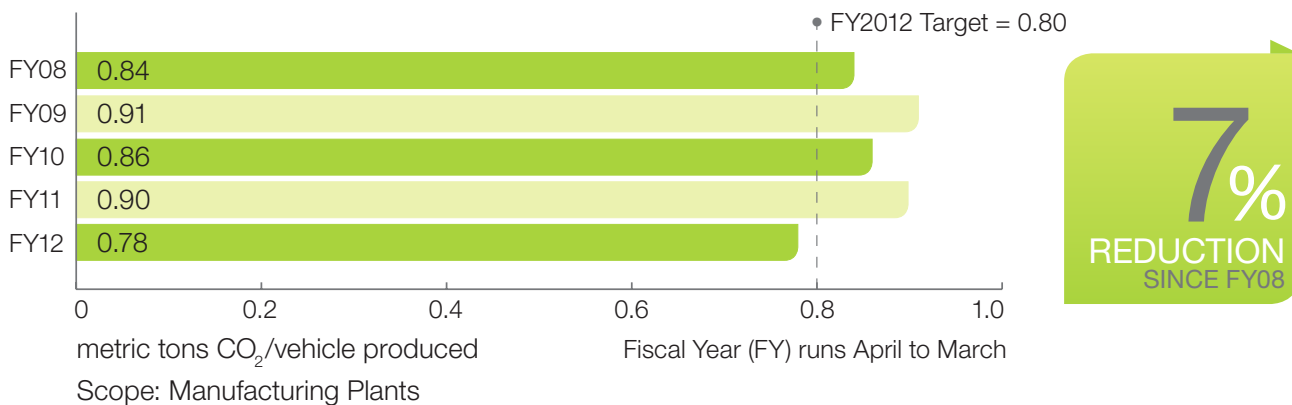

Three of Toyota's North American manufacturing plants were subject to EPA's Mandatory GHG Reporting rule. Individual plant data for our plants in Kentucky, Texas and Indiana are available on the U.S. Environmental Protection Agency's website through its online data publication tool.

We are also disclosing GHG emissions from Toyota's North American companies as a consolidated inventory. Toyota's North American GHG inventory measures GHG emissions from the consumption of electricity and natural gas at plants, logistics sites and owned and leased office space, as well as from fuel consumption by in-house trucking operations and third-party carriers, employee commuting and business travel. The methodology used to calculate emissions is based on *The GHG Protocol*[®] developed by the World Resources Institute and the World Business Council for Sustainable Development. The process of preparing this consolidated inventory has helped us better understand where GHG emissions occur and has facilitated information sharing across Toyota's North American companies.

FG18 • North American GHG Emissions by Scope

	SCOPE 1 (Direct)	SCOPE 2 (Indirect – Purchased Electricity)	Scope 3 (Other Indirect)
FY2008	437,000	950,000	872,000
FY2009	382,000	767,000	711,000
FY2010	405,000	742,000	710,000
FY2011**	395,000	776,000	720,000

*In keeping with The GHG Protocol[®], the above results do not include several *de minimis* sources, which account for less than five percent of our total emissions.

**Consolidated FY2012 data was not yet available at the time of publishing this report. We will be shifting our data collection process going forward to report this data in the same time frame as our other metrics.

REDUCING GHG EMISSIONS IN LOGISTICS

Fuel consumption from the transport of Toyota production parts, service parts and vehicles is a significant source of GHG emissions. Our logistics operation is committed to improving fuel efficiency and reducing transportation-related GHG emissions. One way they demonstrate this commitment is through EPA's SmartWay[®] program. Our in-house completed vehicle trucking carrier (Toyota Transport) has renewed their membership in SmartWay as a carrier, and our division that manages third-party trucking and rail carriers is a shipper member. Launched in 2004, SmartWay is an EPA program that reduces transportation-related emissions by creating incentives to improve supply chain fuel efficiency.

Initiatives such as driver education, idling reduction and the installation of various aerodynamic equipment have contributed to a combined annual fuel savings of almost 160,000 gallons per year from our in-house service parts and vehicle logistics trucking operations. This translates to over 1,600 tons of GHG emissions avoided per year. In 2012, Toyota is upgrading trucks for its fleet and will see even more improvements in fuel economy and emissions, including a targeted six percent reduction in GHG emissions per ton-mile traveled (a ton-mile is one ton of freight transported one mile and is a common unit of measure for logistics).

Much of our part and vehicle transport activity is conducted by third parties. Because our activities influence the GHG emissions of these third parties, our U.S. sales and logistics operation tracks these emissions and has been working with third-party carriers to reduce GHG emissions from transportation activities.

We conducted research with one of our production parts logistics partners on how aerodynamic equipment installed on trucks could improve fuel economy. We began testing this equipment in 2008, and have since installed the equipment on a number of Toyota's logistics trucks. As a result, there has been a five percent improvement overall in fuel economy. A number of our third-party carriers have also implemented this equipment on their fleets.

At our newest plant in Blue Springs, Mississippi, Toyota is partnering with R.J. Corman Switching Co. to reduce the impact of our rail operations there. R.J. Corman Switching uses a 1,400-horsepower RP14BD GenSet locomotive to provide rail-car switching. The GenSet will enable Toyota to reduce locomotive fuel consumption here by 35 to 55 percent.

RENEWABLE ENERGY

Renewable energy is energy that comes from natural resources such as sunlight, wind, biomass and geothermal heat. Renewable energy replaces conventional fuels primarily in electricity generation and transportation fuels. There is strong public support for promoting renewable sources such as solar power and wind power. Climate change concerns, coupled with rising oil prices and government support are driving renewable energy legislation, incentives and commercialization.

Toyota supports the development of renewable energy sources and has been expanding the use of renewable energy as a means of reducing our carbon footprint and our reliance on non-renewable energy sources. We are evaluating applications of solar, geothermal and stationary hydrogen fuel cells, as well as the purchase of green power either directly from a utility company or through renewable energy credits. Through *hansei*, or reflection, on our pilot applications, we are learning what works and what doesn't and where additional opportunities lie.

SOLAR

Our first renewable generation project began in 2002 with the installation of a 536-kilowatt photovoltaic (PV) system at our U.S. sales headquarters South Campus in Torrance, California. Since going online, this system has generated over 5.1 million kilowatt-hours of electricity. We also have rooftop PV systems at parts distribution facilities in California and New Jersey that generate a total of 3.8 megawatts of electricity.

Toyota's North American manufacturing plants have been experimenting with different applications of PV systems since 2008. Three locations have tested solar applications:

- Our plant in Huntsville, Alabama, installed a five-kilowatt system to understand basic information on installation costs, true power output and operational expenses.
- Our Blue Springs, Mississippi, plant installed solar panels on light poles in the visitor parking lot. A battery is used to store energy during daylight hours and a sophisticated battery management system ensures lighting levels meet required standards based on occupancy sensors. This location was selected to provide a showplace for this lighting technology and permits Toyota to evaluate this solution to parking lot lighting needs.
- A fountain at the Environmental Education Center | Nature Trail at our plant in Georgetown, Kentucky, is powered by a solar panel, providing an opportunity to educate visitors about solar power and renewable energy.

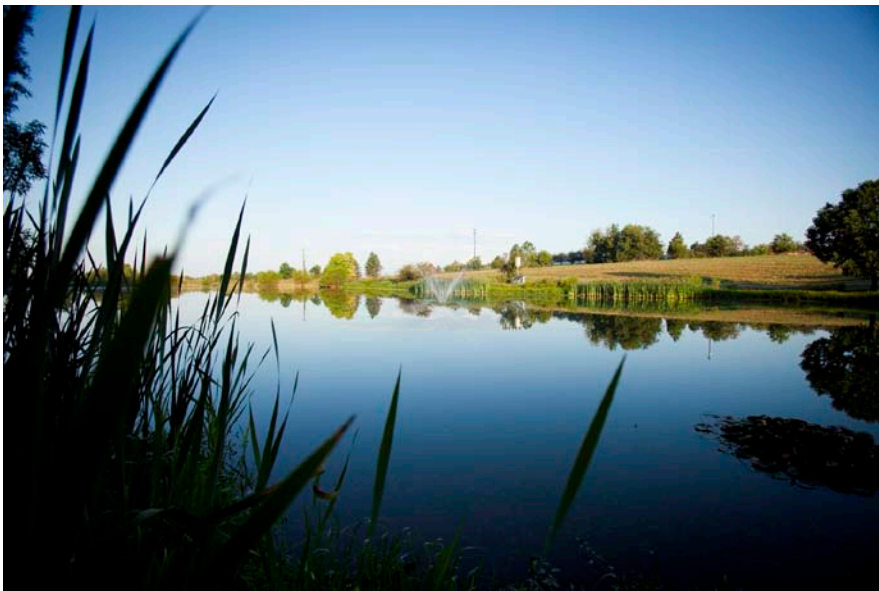

At our plant in Georgetown, Kentucky, a fountain at the Environmental Education Center | Nature Trail is powered by a solar panel. We use the fountain to educate visitors about solar power and renewable energy.

GEOTHERMAL

In addition to solar power at the Blue Springs plant, we have been studying a geothermal application for providing chilled water required by the air compressor. Designs for a geothermal well field consist of 15 geothermal wells and a chiller to provide 20 tons of chilled water to a compressed air dryer on weekends. The central chilled water would be provided by several 2,000-ton chillers that consume approximately 1,500 kilowatts per hour. Once implemented, anticipated energy reduction potential is over one million kilowatt-hours per year. If this system works as anticipated, we will complete *yokoten*, or transfer and adapt this system to other manufacturing facilities in North America.

HYDROGEN FUEL CELL

Toyota's U.S. sales headquarters installed a 1.11 megawatt stationary hydrogen fuel cell to generate electricity and reduce utility costs. The fuel cell became operational in 2012 and uses hydrogen produced off-site from natural gas. To offset the greenhouse gas impacts of the hydrogen production, an equivalent amount of landfill-derived methane gas is purchased and put into the natural gas pipeline.

The fuel cell uses Proton Exchange Membrane (PEM) technology, which is similar to the technology used in Toyota's fuel cell hybrid vehicle (FCHV). PEM fuel cells are used in Toyota vehicles because they can be turned on and off quickly. Using similar technology to responsively provide electricity to our sales campus during peak demand periods demonstrates another reliable use of this technology. This is the largest PEM fuel cell in the world and is the first application of its kind.

RELATED TOPICS

- For information about Toyota's FCHV, please visit [**Green Innovation/Future Transportation/Hydrogen Fuel Cell Hybrid Vehicles**](#).

GREEN POWER PURCHASES AND RECS

We also support the expansion of renewable power through the direct purchase of renewable energy from our electricity providers as well as through renewable energy credits (RECs). The vehicle distribution center in Portland, Oregon, and the Lexus Training Center in Dallas, Texas, purchase renewable power directly from green power utilities.

In contrast to direct renewable power purchases, RECs are tradable commodities that represent proof that a certain amount of electricity was generated from an eligible renewable energy resource. When we purchase RECs, we specify the type of generation (typically wind) and the location from which the RECs are generated. In particular, we seek to purchase RECs from generating facilities that are NOT in a state that has Renewable Portfolio Standard (RPS) requirements to help increase market demand for renewable generation. We purchase RECs for our regulatory affairs office in Washington, D.C., and training centers in Florida, Arizona and California.

SPOTLIGHT: RENEWABLE ENERGY PROJECTS AT OUR SALES AND LOGISTICS SITES

In our sales and logistics division, we have used four methods to reduce the environmental impacts of our energy consumption. The primary focus is on energy efficiency—reduce consumption by optimizing building systems operations and energy efficiency projects, such as the lighting retrofit projects outlined [**above**](#). Although not universally applicable at every one of our facilities, we also look for opportunities to purchase renewable energy directly from local utilities, install on-site renewable generation, and purchase Green-e certified renewable energy credits (RECs). We consume a total of 91 million kilowatt-hours of electricity annually, and we currently support over seven million kilowatt-hours of renewable energy generation through a number of projects.

FG19 • Renewable Energy at Our Sales and Logistics Sites

Approximately 5.5 percent of the total electricity needs of Toyota's U.S. sales, distribution and government relations buildings is generated by a renewable power source.

	LOCATION	RENEWABLE ENERGY
Direct Utility Purchased Renewable Energy	Vehicle Distribution Center in Portland, Oregon	930,000 kWh
	Lexus Dallas Training Center, Texas	190,000 kWh
Photovoltaic Distributed Generation Installations	Toyota Motor Sales – South Campus	570,000 kWh
	North American Parts Center in Ontario, California	3,200,000 kWh
	Parts Distribution Center in West Caldwell, New Jersey	1,700,000 kWh*
Renewable Energy Credits	Regulatory Affairs office in Washington, D.C.	260,000 kWh
	Lexus Florida Training Center	67,000 kWh
	Toyota Phoenix Training Center	150,000 kWh
	Toyota Inland Empire Training Center	87,000 kWh

*For this installation, Toyota is only purchasing the power from the third-party owned photovoltaic system on our roof and not its green attributes. These attributes are being sold by the system owner on the REC market.

RELATED TOPICS

- Please visit [Green Innovation/Future Transportation/Alternative Transportation Fuels](#) for more information on renewable transport fuels.

GREEN BUILDING

“Green building” refers to sustainable practices throughout a building’s life cycle, from siting to design, construction, operation, maintenance, renovation and demolition. The objective of green building practices is to reduce the overall impact of the built environment on human health and nature by efficiently using energy, water and other resources; protecting occupant health; and reducing waste and pollution.

According to the Environmental Protection Agency (EPA), the buildings in which we work, shop, play and educate our children in the United States use about \$200 billion worth of electricity and natural gas each year. EPA estimates that if the energy efficiency of commercial and industrial buildings in the U.S. improved 10 percent, Americans would save about \$20 billion and reduce greenhouse gases equal to the emissions from about 30 million vehicles. In fact, the energy used by commercial and industrial buildings in the United States is responsible for nearly 50 percent of our national emissions of greenhouse gases that contribute to global climate change.

Toyota has over 37,600 employees working in office space, distribution centers and manufacturing plants across North America. Green building principles help us design, build, renovate and manage these spaces in a more sustainable manner.

Toyota's sales and logistics division, Toyota Motor Sales, U.S.A., Inc. (TMS), has been a member of the United States Green Building Council (USGBC) since 2002. The USGBC administers the Leadership in Energy and Environmental Design (LEED®) program, a point-based program that promotes a whole-building approach to sustainable construction and remodeling. LEED certification provides independent, third-party verification that a building was designed and built using strategies aimed at achieving high performance in key areas of human and environmental health: sustainable site development, water savings, energy efficiency, materials selection and indoor environmental quality. Through this membership and through other avenues, we have provided advice on sustainable facilities development and operations to a number of organizations, including Yellowstone National Park, surrounding communities, nonprofit organizations and other corporations.

While we do not apply for LEED certification in all cases, we do use integrated design principles and incorporate sustainable elements in each building design phase. We learn from each project as we reflect on what worked and what could have been improved. *Hansei*, or reflection, ensures we continue to learn from our experiences and apply this learning to future projects.

We also apply green building principles when we construct our assembly plants. Prior to beginning construction on a new assembly plant or a major expansion of an existing plant, Toyota develops an "Eco-Plant Plan" that maps out the use of best available technology to minimize environmental impacts and meet or exceed regulatory requirements. Each plan contains operational performance targets for energy use, emissions of volatile organic compounds (VOCs), waste generation and water consumption. These plans consider best practices and are tailored to local conditions.

After the plans have been developed and approved, audits are conducted throughout the construction and trial phases to verify that the plan has been followed. Most recently, Toyota implemented an eco-plant plan for our newest manufacturing facility in Blue Springs, Mississippi (opened in 2011).

PERFORMANCE

A total of 11 Toyota and Lexus facilities have achieved LEED certification. Ranging from office space to vehicle distribution centers, these facilities represent Toyota's continued efforts to improve the design and efficiency of all operations.

Our U.S. sales headquarters South Campus in Torrance, California, is Toyota's first LEED-certified building. South Campus had its grand opening in 2003 and is certified to LEED Gold. Since 2003, over five million kilowatt-hours of grid power use have been avoided through the use of our rooftop photovoltaic system. This facility formed the basis for our expertise on green building and is frequently toured by business partners and community members wanting to learn more about green building principles.

Our most recent site to achieve LEED certification is the Kansas City Technical Training Center in Missouri. The technical training center is located at the region sales office and provides classrooms and training bays for Toyota dealer technicians. The Kansas City Technical Training Center integrated the following LEED elements into construction to achieve Gold certification:

- More than 953 tons—99 percent of construction waste—was diverted from landfill through salvage or recycling.
- Extensive native vegetation rain gardens and swales treat 100 percent of parking lot and roof stormwater runoff, removing 95 percent of pollutants.
- Automatic lighting controls and use of natural light reduce electrical demand by almost 25 percent.
- Dual flush toilets, waterless urinals and efficient fixtures reduce water consumption by 66 percent, saving 49,800 gallons of water annually.

FG20 • Toyota’s North American Facilities With LEED Certifications

TOYOTA FACILITY	LOCATION	YEAR	CERTIFICATION LEVEL
Toyota Kansas City Training Center	Kansas City, Missouri	2012	NC Gold
Toyota Inland Empire Training Center	Rancho Cucamonga, California	2010	CI Gold
Toyota Motor North America, Inc.	New York, New York	2010	CI Gold
Toyota Technical Center	York Township, Michigan	2010	NC Gold
Toyota Racing Development North Carolina	Salisbury, North Carolina	2010	NC certified
Lexus Florida Training Center	Miramar, Florida	2009	CI Gold
Toyota Phoenix Training Center	Phoenix, Arizona	2009	CI Silver
North America Production Support Center	Georgetown, Kentucky	2006	CI Silver
Toyota Motor North America, Inc.	Washington, D.C.	2006	CI Silver
Portland Vehicle Distribution Center	Portland, Oregon	2004	NC Gold
Toyota Motor Sales – South Campus	Torrance, California	2003	NC Gold

NC = new construction CI = commercial interiors

RELATED TOPICS

- Since obtaining LEED Certification on our corporate facilities, 24 of our dealerships have followed our lead. Pat Lobb Toyota in McKinney, Texas, was the first automotive dealership in the world to obtain LEED certification. For information on green building programs with our Toyota and Lexus dealerships, please visit [Supporting Business Partners/Dealerships](#).

WASTE MINIMIZATION

Waste refers to everything from office trash to cafeteria scraps and industrial waste. If waste is generated, then natural resources were consumed: The more waste that is generated, the more resources are consumed. And, if waste is not managed properly, it can pollute the environment and impact human health.

Waste minimization practices help us conserve the natural resources needed to make our vehicles, which in turn help us manage costs. These practices also help us find the best solution for processing the waste we generate: We work with our business partners to find ways to reuse or recycle what we can; we compost cafeteria waste in locations where composting is feasible; our waste is used as fuel in waste-to-energy facilities; and we divert as much as we can from going to landfill.

Creating a recycling-based society is one of the action guidelines in the [Toyota Earth Charter](#). In North America, we see our efforts to accomplish this as key to being a good neighbor in the communities where we live and work. To further encourage recycling in our society, we partner with other businesses and nonprofit organizations to find outlets for our waste, as well as to help them find better ways for managing their own waste.

WASTE REDUCTION AWARDS

In 2011, the U.S. Environmental Protection Agency (EPA) selected Toyota's U.S. sales and logistics division, Toyota Motor Sales, U.S.A., as the **WasteWise Large Business Partner of the Year** for our efforts to reduce waste and increase recycling. We are the only Large Business in the nation to receive this distinction.

This follows on and surpasses our **Waste Reduction in the Workplace Gold Achievement Honorable Mention award** that we received in 2010. The WasteWise Awards are the result of a team effort—23 sales and logistics sites participate in the program. Through these efforts, Toyota Motor Sales:

- Reduced 36 million pounds of waste (63 percent).
- Recycled 18.8 million pounds of waste (33 percent).
- Recovered energy from 1.1 million pounds of waste (two percent).
- Sent only one million pounds of waste to landfill (two percent).

In addition to WasteWise, three of Toyota's California parts distribution facilities were recognized in 2011 by the **Waste Reduction Awards Program (WRAP)** administered by the California Integrated Waste Management Board. This program recognizes California businesses and nonprofit organizations for their outstanding waste reduction efforts. Since the WRAP program began in 1994, Toyota has won a total of 70 awards, including two **WRAP of the Year** awards.

TARGETS AND PERFORMANCE

2012 Targets: Reduce non-saleable waste from manufacturing plants to 17.80 kilograms per vehicle (missed); Achieve zero waste to landfill (achieved by 10 of 14 plants)

Non-saleable waste is waste that we pay to dispose (such as by incineration, landfill or converted to energy). We set a target to reduce non-saleable waste at our manufacturing plants to 17.80 kilograms per vehicle, a two percent reduction from fiscal year 2011 levels. We missed this target; our volume of non-saleable waste increased to 18.78 kilograms per vehicle. The primary reason for missing the target is that we performed a number of “spring cleaning” and plant refurbishment activities during planned non-production times last year. These cleaning events normally would have happened over the course of a longer time period, but we took advantage of the non-production times to complete these activities early.

Despite missing this target, our plants found numerous ways to reduce the amount of waste they generate. Team members examine processes closely to find opportunities for reduction. They take personal responsibility for finding solutions, and their creativity and commitment lead to our successes.

For example, team members at our plant in West Virginia identified a *kaizen*, or continuous improvement, to reduce coolant waste. The plant recycles steel and aluminum chips that contain residual coolant. During storage at the recycling facility, coolant drips off the chips and is collected and disposed. Last year, the recycler had to pay to dispose of 100,000 gallons of coolant.

To minimize the amount of coolant sent to the recycler, team members installed a sloped false bottom into a 20-yard roll off box with a filtering screen at the front. This allows the coolant to drain by a valve in the front of the box into a 30-gallon tote. The coolant is then recycled into the plant’s coolant system. This innovative solution eliminates a waste stream and significantly reduces the amount of new coolant Toyota needs to purchase each year.

Many other waste materials, like plastic wrap, paint solvents, used oil and packaging materials, are recycled. Our Kentucky plant recycles engine block modules, the steel shipping containers used by our parent company in Japan to ship engines to the United States.

Virtually 99 percent of all scrap steel generated by Toyota plants is recycled. Toyota’s Kentucky plant uses an intricate system that turns scrap steel from the stamping process into reusable product. Scrap steel—in the form of approximately 600-pound cubes—is returned to the mill and is eventually put back into the production process as steel coils. In addition, when doors are made in the stamping process, there is steel from the window area left over. We send these squares of top-quality steel to sub-suppliers, who in turn use our steel as their raw material. From this steel, the suppliers make internal structural pieces for the vehicles made at the Kentucky plant.

FG21 • Non-saleable Waste

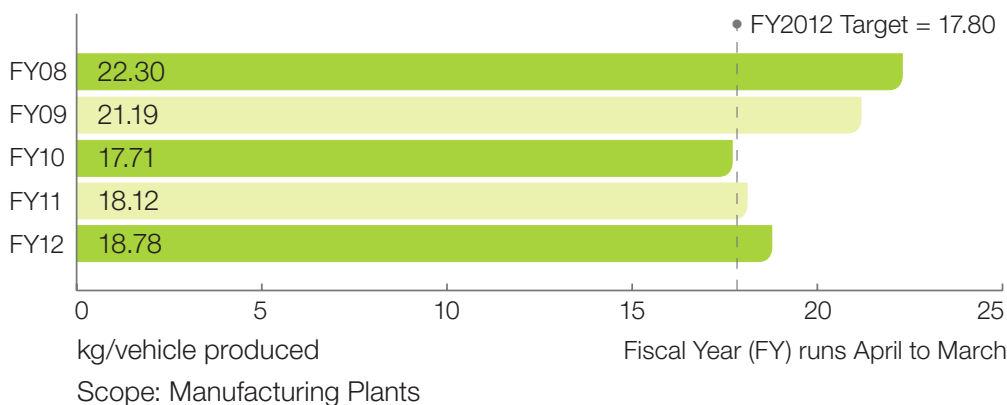

13%
REDUCTION
SINCE FY08

ZERO WASTE TO LANDFILL

We have an annual target to achieve zero waste to landfill at our North American manufacturing plants. Ten of our plants achieved zero waste to landfill in fiscal year 2012, meaning they sent no waste directly to landfill. (Some waste is sent to incineration and waste-to-energy facilities; those facilities may send the resulting ash to landfills if no beneficial use can be found.)

Our zero waste to landfill metric is driven by the Toyota Production System, where the elimination of *muda*, or waste, in all aspects of business is a main objective. Toyota's parent company in Japan has challenged plants worldwide to send zero waste to landfill. While this has not resulted in the elimination of all waste, it has required significant focus on all three "R's": Reduce, Reuse and Recycle. Countless *kaizens*, or continuous improvements, help us get closer to the elimination of all waste.

Our plants use tools (such as color-coded waste bins and signs) to assist team members in segregating waste types and maximizing the number of waste streams that can be recycled. Some of our noteworthy achievements include:

- Our plant in Huntsville, Alabama, has been zero waste to landfill since the start of production in 2003—this is the first of our plants to be zero waste to landfill from the start of production.
- Toyota's two largest North American manufacturing plants—in Georgetown, Kentucky, and Cambridge, Ontario—have achieved zero waste to landfill for over five years. Both of these plants compost waste from their cafeterias. At the Georgetown plant, the compost is used for grounds maintenance and in a greenhouse, where team members grow produce to donate to local families in need.

Many of our non-production sites also pursue zero waste to landfill. At our Canadian sales offices, 96 percent of their waste was diverted from landfill in calendar year 2011. This was achieved by recycling, reusing and composting, and no waste was incinerated.

Our U.S. sales and logistics locations achieved a 90 percent recycle rate in fiscal year 2012. Eight of these locations are zero waste to landfill facilities. Last year, the parts and vehicle distribution centers diverted 97 percent of their waste from landfill and recycled almost 20 million pounds of material.

FG22 • Logistics Recycling

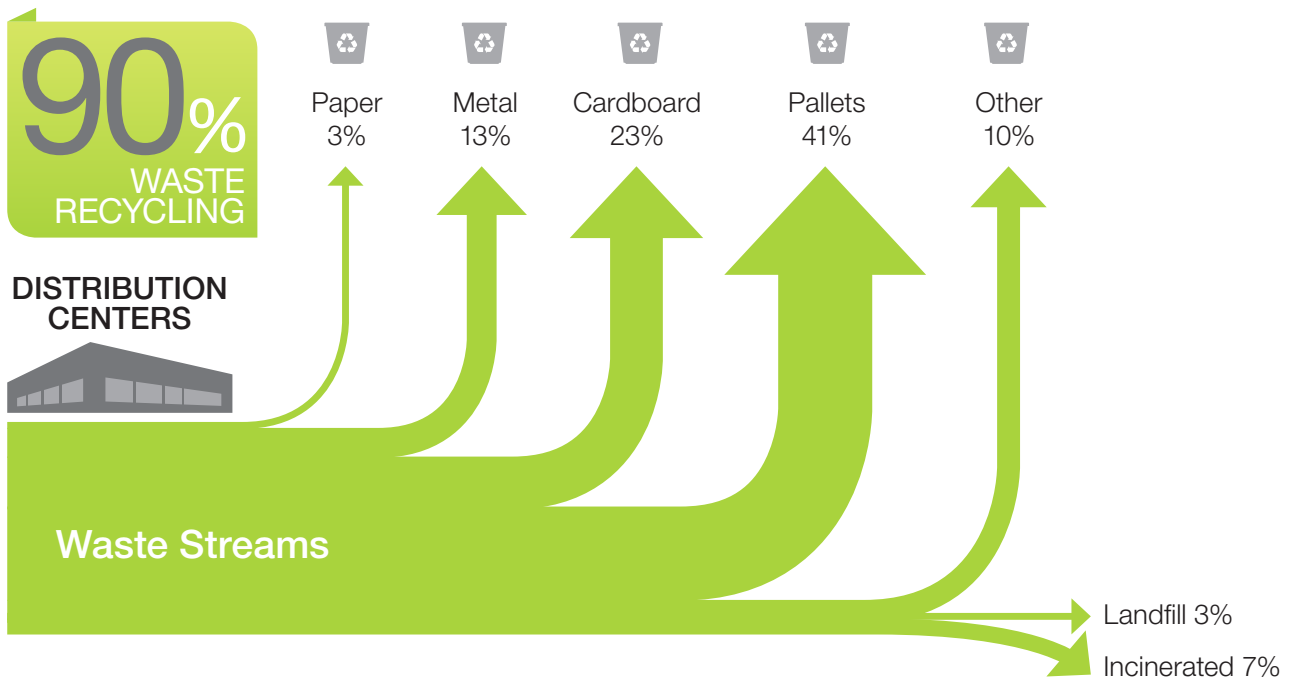

SPOTLIGHT: PACKAGING REDUCTIONS

Toyota's North American Parts Operations division uses over 60,000 reusable metal shipping containers in place of cardboard and wood pallets, up from only 30,000 just a few years ago. These returnable containers are used between selected North American parts distribution centers and vehicle distribution centers, dealers and suppliers. The returnable containers are also used increasingly for shipments to Canada, Mexico and Puerto Rico. Over 120 of Toyota's North American suppliers also use returnable containers.

More than 95 percent of the North American parts at Toyota's Kentucky and Texas plants are currently received in returnable packaging. This direct reuse of containers helps to conserve our natural resources and keeps waste out of landfills.

During fiscal year 2012, we saved 37 million pounds of wood and 13 million pounds of cardboard due to the use of returnable shipping containers. Since the use of these containers began in 2001, our cumulative savings amount to over 129 million pounds of wood and 48 million pounds of cardboard, as well as packaging cost savings approaching \$1 billion.

FG23 • Returnables Program Savings

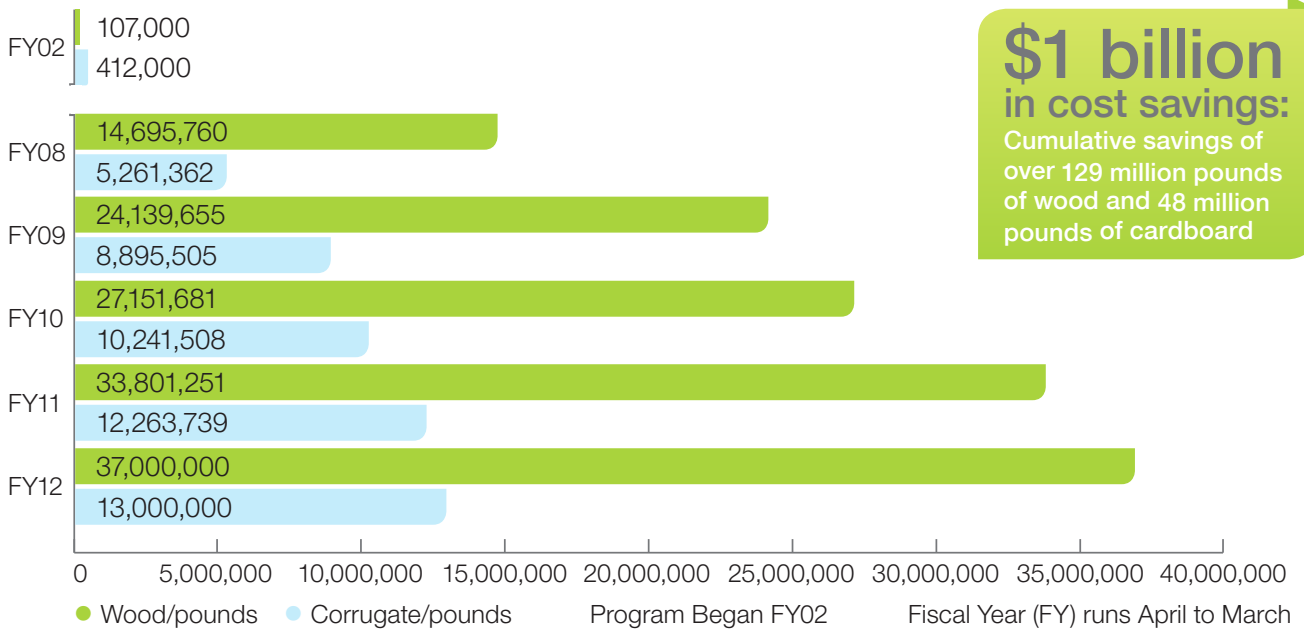

\$1 billion
in cost savings:
Cumulative savings of
over 129 million pounds
of wood and 48 million
pounds of cardboard

RELATED TOPICS

- In addition to minimizing the waste we generate in our own operations, we also work to ensure that the vehicles we make are recyclable. Huge shredders allow steel and non-ferrous metals to be recycled, and new processes also enable the recycling of car materials like urethane foam, copper, glass and plastic bumpers. Toyota vehicles are now 85 percent recyclable. We design our vehicles to be made with recyclable materials to facilitate this process. For more information, please see [Green Innovation/Chemical Management](#).
- We also help our communities properly recycle and dispose of household hazardous waste and e-waste. For more information on our collection events, please visit [Strengthening Communities/Local Community Engagement](#).
- Watch a short video about TOYOTA'S process for CONVERTING WASTE into garden fresh produce.

PARTNERSHIP: JACKSON COUNTY DEVELOPMENT CENTER

Since 2004, team members from our plant in Buffalo, West Virginia, have been collecting and baling plastics to donate to the Jackson County Development Center. The center sorts and sells the plastics, using the income to provide training and employment opportunities to the disabled.

In 2008, team members visited the Jackson County Development Center to see how the plastics were sorted, and we found that quite a bit of trash was mixed with the plastics. So we figured out how to better segregate waste streams to decrease the amount of trash that goes to the center.

This *genchi genbutsu*, or “go, see and find facts to analyze the root causes,” is one of the five practices of the Toyota Way: To make correct decisions, you must go to the source of an issue and observe. Determining the facts increases the likelihood of identifying problems and their root causes.

Since 2009, the Jackson County Development Center has been selling plastic donated by Toyota to PTI, Incorporated. PTI grinds, melts and forms the plastic into flying discs (similar to Frisbees®). Toyota buys the flying discs from PTI to hand out during local events. The flying discs help Toyota team members who volunteer at schools and other local events teach children about recycling and what each of us can do to help protect our world.

In recognition of Earth Day in 2011, team members from the plant visited 20 fifth graders from Leon Elementary School in Leon, West Virginia, to discuss the environment and what each of us can do to help protect our world. Our presentations focused on simple things like “reduce, reuse and recycle.” We also brought a Toyota Prius to the school for the students to see and talked with them about its ground-breaking technology. Each student went home with a Go-Green Earth Day T-shirt and a flying disc made of recycled plastic from the plant.

“Children are asked to recycle, but they almost never see the results of their labor,” said George Vickers, a Specialist in Environmental Engineering at Toyota’s West Virginia plant. “We give them a tangible example of our own plastic recycling. The kids love the flying discs, and we love the opportunity to teach sustainability with a fun toy they can easily relate to.”



William Hayman poses with his fifth-grade class from Leon Elementary School during an Earth Day event at our plant in Buffalo, West Virginia. George Vickers, a Specialist in Environmental Engineering, gave each student a green flying disc made of recycled plastic from the plant.

WATER

There is growing concern about the availability of sufficient fresh water to sustain our planet in the coming decades. In North America, we are concerned with the declining quality of fresh water sources and scarcity during droughts.

Water issues concern the communities around us, and a number of our North American manufacturing sites have experienced water-related stresses firsthand. In Georgetown, Kentucky, drought conditions have caused restrictions on water use and have led to the need for increased chemical treatment of harder water. In Troy, Missouri, Bodine Aluminum, one of Toyota's casting plants, drilled its own well to reduce dependence on city water during summer droughts. Conditions such as these are expected to worsen over time unless countermeasures are undertaken.

Toyota globally considers water to be one of its priority environmental issues. When evaluating water across our North American operations, we consider many things such as how much water we use, how much water we discharge, the quality of the water we discharge, use of recycled or reused water, and stormwater management. To help us manage the wide array of water-related issues, Toyota has a North American Water Group, where a consensus approach is used to identify general direction and set targets.

Our water management strategy focuses on a 3Rs Analysis—Reduce, Reuse and Recycle. In the water conservation pyramid, reduce is the foundation and provides the most opportunities for improvement at the lowest cost. It is the fundamental first step in water management. Reuse is in the middle, with recycling at the top. Reuse may require only simple filtration to utilize a process wastewater stream for makeup to another nearby process, whereas recycling is the most costly and difficult to implement of the three “R’s.” Our long-term strategy focuses on “renewable” water—using innovation to make recycling more viable.

THE TOYOTA WAY: KAIZEN WATER BLITZ

A water blitz is one of the tools we use to find opportunities to reduce water use. A *kaizen* is Japanese for change for the better and, along with standardized work, is a key element of continuous improvement. *Kaizens* are often small changes to a process that, when added together, significantly improve results. A successful *kaizen* relies on the involvement of all employees, a willingness to change and communication. When applied in a blitz format, individual *kaizens* are identified and quickly addressed, rapidly removing waste or inefficiencies.

A “*kaizen* water blitz” is conducted by a team of experts while spending a week at a host plant studying the processes that use water, understanding usage and finding ways to make improvements. “Low hanging fruit” and obvious ideas for *kaizens* are generated in this blitz format, and also inform the next step of the improvement process.

The next step is called a *jishuken*, or in-depth study, of our largest water users. We generate a water balance—the volume and quality of water coming in to a process, and the volume and quality going out—looking at water use from all angles. We study each process that uses water to look for inefficiencies and opportunities. By understanding the chemical components in the water, we can find uses for waste streams at other nearby processes that we may not have identified in the blitz. We understand how and why water is used and develop reduction strategies, keeping product quality in the forefront every step of the way.

STRATEGY: STORMWATER MANAGEMENT

Stormwater is rainwater and melted snow that runs off streets, parking lots and other impervious surfaces. When stormwater is absorbed into the ground, it is filtered and ultimately replenishes aquifers or flows into streams and rivers. Impervious surfaces such as pavement and roofs prevent precipitation from naturally soaking into the ground. Instead, the water runs rapidly into storm drains, sewer systems and drainage ditches. If unattended, there is potential for debris, chemicals, sediment or other pollutants to accumulate and contaminate streams and rivers.

Toyota is concerned about the impact our operations have on local water bodies. Because of the potential for stormwater to contaminate local streams, we start managing stormwater even before our plants are built. As our plants are designed, we evaluate how water will flow across the property and establish best practices to minimize the risk of contamination from our operations.

Many of our plants were built decades ago, and periodically we need to re-examine our management practices to ensure we are still minimizing risk. We wanted to evaluate our situation across North America and find ways to improve that go beyond compliance with local, state and provincial requirements and federal regulations.

During the course of last year, engineers from headquarters visited all 14 North American manufacturing plants plus three design and research centers to conduct a stormwater risk assessment. At each location, these engineers were joined by a member of the facilities group and a member of the environmental department. Together, they reviewed stormwater permits and site drawings to understand how water flows through the site and where water is discharged from the site.

The risk assessment team performed three activities as part of a *genchi genbutsu*, or “go, see and find facts to analyze the root cause”: a roof walk, a perimeter walk and a site drive. During the roof walk, the team evaluated rooftop equipment such as exhaust fans, HVAC units and roof-mounted cooling towers; if this equipment leaks on the roof, run-off has the potential to reach roof drains and eventually make its way to stormwater retention ponds. The team then walked the building perimeter to evaluate equipment, tanks and containment areas. During the site drive, the team examined areas where water leaves the site, in particular sluice gates at stormwater retention ponds. These activities helped the team understand where and how contamination of stormwater could occur. Each point of potential contamination was rated based on the level of possible impact to the environment and possible frequency of occurrence.

The team applied concepts of the Toyota Way throughout the assessment, including the practice of *hansei* to examine the current situation and identify the problem. Results of the risk assessment will be used in creating a North American plant stormwater master maintenance plan and an updated internal standard operating procedure to reduce the risk of leakage. These plans and procedures will be rolled out in fiscal year 2013.

TARGET AND PERFORMANCE

2012 Target: Reduce water usage to 0.92 kilogallons per vehicle at Toyota's North American manufacturing plants (achieved)

Toyota's assembly plants are our biggest users of water. Our sales and logistics sites use water primarily for landscaping and sanitation; these volumes are insignificant compared to the volume of water used for cooling and painting at our assembly plants.

Toyota's manufacturing plants set a target to reduce water usage to 0.92 kilogallons per vehicle in fiscal year 2012. We exceeded this target and reduced water usage by two percent, to 0.90 kilogallons per vehicle.

At Toyota's plant in Long Beach, California, water use in the cooling tower was fluctuating from month to month. Mechanical failures that occurred after production hours ended went undetected and were causing spikes in water use. Team members installed a system that tracks water parameters in real time and sends an email alert if there is an issue. A number of parameters are monitored including pH level, temperature, turbidity, polymer consumption and average circulation rate. Installing this system has led to a 59 percent reduction in water use, from over 6,300 gallons per day to just over 2,500 gallons per day. We saved 1.2 million gallons of water during fiscal year 2012. We also reduced our chemical use by 67 percent, since we weren't treating as much water. We used only 55 gallons of water treatment chemicals in 2011 compared to 165 gallons in 2010.

FG24 • Water Use

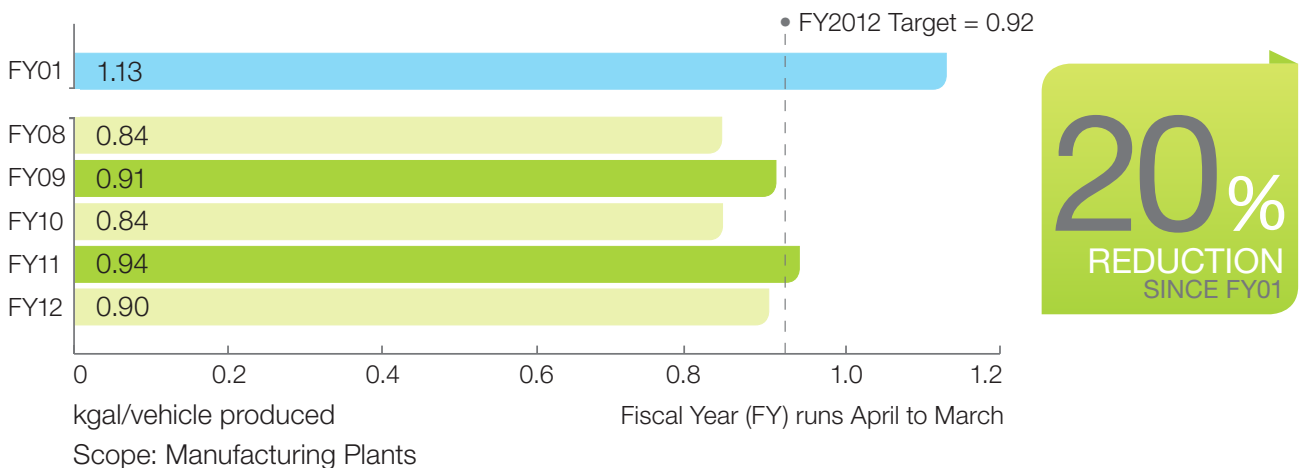

SPOTLIGHT: WATER SAVINGS AT OUR PLANT IN CAMBRIDGE, ONTARIO

Toyota Motor Manufacturing Canada (TMMC) has vehicle assembly plants in Cambridge and Woodstock, Ontario. Toyota produces the RAV4 and RAV4 EV in Woodstock, and the Toyota Matrix, Corolla and the Lexus RX 350 in Cambridge.

Fresh water supplies are coming under increasing pressure, and the Region of Waterloo in Ontario is concerned about adequate water supplies to serve the region in the future. Ontario is projected to grow by an additional 3.3 million people by 2031. This growth rate could put much greater demands on local water resources.

At the same time, scientists are predicting that climate change will create greater uncertainty for water resources. They foresee more severe and unpredictable weather events, flooding and drought. Climate change models suggest that water levels in the Great Lakes will be more variable. They could decline significantly due to higher evaporation rates and less snow and ice cover in winter. Warmer temperatures could also drive up water demand, particularly during summer.

Managing Ontario's water resources to achieve more sustainable use isn't just good for the environment—it's essential for Ontario's economic prosperity. The Great Lakes Region, for example, accounts for 95 percent of the province's farm income, while fishing and shipping add more than CAD\$7 billion annually to Ontario's economy.

The region of Waterloo launched the Water Efficient Technology (WET) program as a way to provide incentives to manufacturers to reduce water use. The region hopes to decrease water consumption by more than 6,800 cubic meters (1.8 million gallons) per day through this program.

The Cambridge plant is Toyota's second largest water consumer in North America. In 2007, engineers recognized that TMMC would have difficulty meeting the long-term North American water reduction target for fiscal year 2011.

One of the reasons for high water consumption in Cambridge is the way the water treatment plant works. The water treatment plant's reverse osmosis (RO) units use membrane-technology filtration methods to remove minerals from municipal water to produce ultra-pure water for the painting process. These units reject 25 percent of the incoming municipal water to the sewer as concentrate water. The rejected concentrate is the facility's largest water consumer at 500 cubic meters (132,000 gallons) per day. Recycling this lost concentrate water was seen as the best opportunity to reduce the volume of water used.

Team members at the plant spent two years researching solutions to the problem. They began with *hansei*—examining the issue closely, taking responsibility and committing to finding a solution. Four RO system manufacturers were asked to provide options, but none could offer a solution that didn't involve the use of cleaning chemicals, generate huge amounts of sludge, or cause instability in the overall process.

Instead, team members, led by John Goodfellow and Rob Coveney, designed and installed a Reverse Osmosis Concentrate Recovery System that uses a brackish water membrane. A brackish water membrane was chosen for the system because the main RO concentrate water that was discharged to the sewer water closely resembles seawater. This RO system was initially designed to recover up to 40 percent of the facility's rejected concentrate water, and through experimentation we found we could recover 50 percent.

FG25 • Reverse Osmosis Concentrate Recovery System

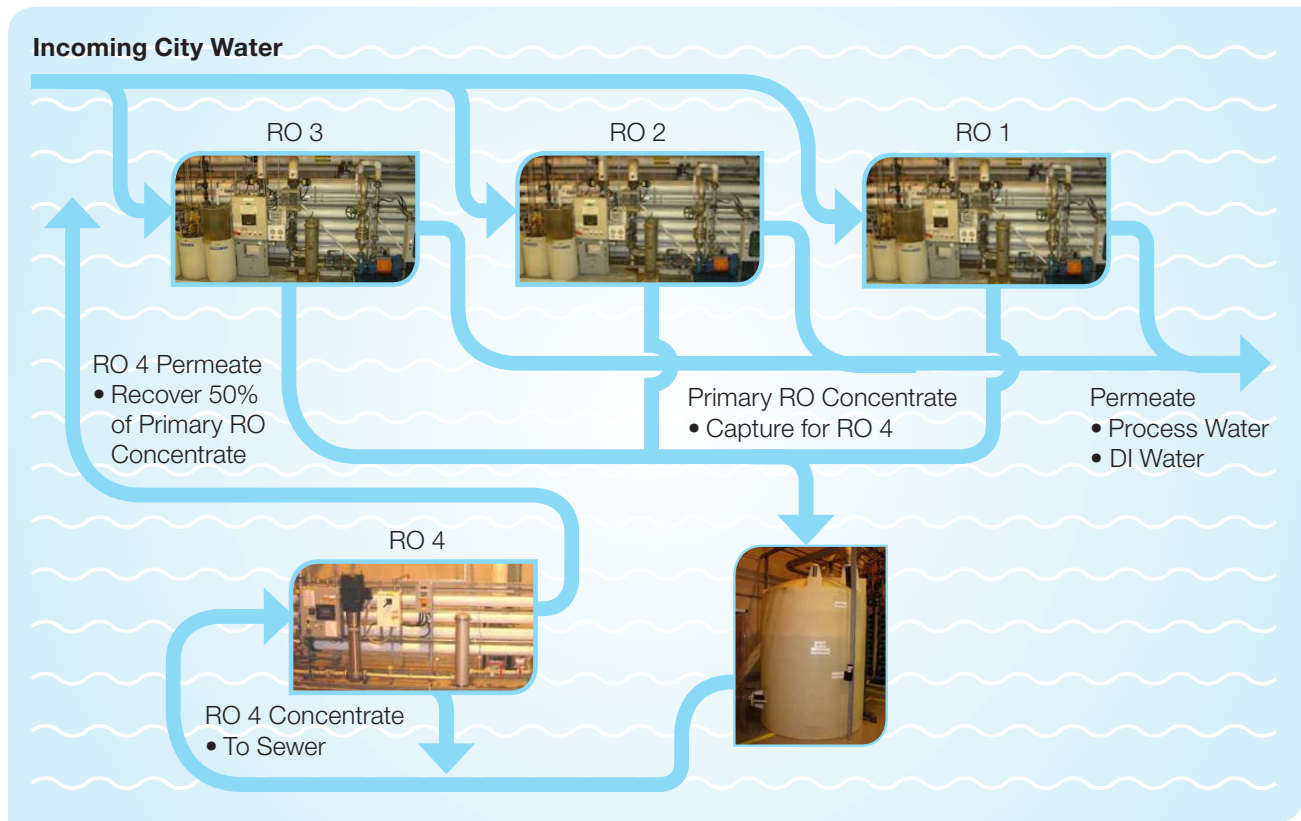

Toyota has two patents pending on this process, one for recovering heat from air compressors to optimize the RO feed water temperature (if the feed water is too cold, the RO membranes close up and reject more water), and one for predicting when the RO membranes should be cleaned so the membranes don't get damaged.

Thanks to the innovative thinking of John and Rob, this system has had overwhelming success. In the first two years of operation, Toyota saved 36,000 cubic meters (9.5 million gallons) of water per year, or 100 cubic meters per day. This is enough water to supply the daily requirements for an estimated 154 homes. The plant also saves almost \$77,000 in municipal water costs each year. With a one-time incentive of almost \$36,000 from the Region of Waterloo's WET Program, the project payback was just one year.



Rob Coveney and John Goodfellow are two of the engineers at our manufacturing plant in Cambridge, Ontario, who helped to develop a reverse osmosis concentrate recovery system that is saving the plant over 50,000 cubic meters (13.2 million gallons) of water annually.

The permeate (good water) from the recovery RO is fed back into the feed water of the main ROs. After determining that the water quality was stable, the Cambridge plant began feeding recovered permeate directly into the process water. After optimization, the recovery RO now saves one month of the plant's water, or 50,000 cubic meters (13.2 million gallons) annually.

TMMC received a **Water Efficiency Excellence Award** from the Region of Waterloo; this is the largest project supported by the WET program.

We are working on transferring and adapting the RO concentrate recovery system to our plant in Georgetown, Kentucky, our largest water consumer in North America.

RELATED TOPICS

- For information on how we work with schools to raise students' awareness about water quality issues, please see **[Strengthening Communities/Local Community Engagement](#)**.

TOYOTA

2012

NORTH AMERICAN **ENVIRONMENTAL REPORT**

SUPPORTING BUSINESS PARTNERS

- > SUPPLIERS
- > DEALERSHIPS

Supporting Business Partners is a chapter in the Toyota 2012 North American Environmental Report. Read the entire report online at Toyotaenvironmental.com or scan the QR code to access the report with your mobile device.





To watch a short video about how a TOYOTA dealership achieved LEED GOLD certification on your mobile device, scan the QR code below.



> SUPPORTING BUSINESS PARTNERS

Toyota's principal business partners are suppliers and dealerships. We work with both of these groups in North America to encourage them to support our environmental values and goals.

When engaging with our business partners, we use the same principles from the Toyota Way that guide our own actions. We practice *hansei* and promote the process of setting targets and conducting treasure hunts to find *kaizens*, or continuous improvement opportunities. Together, we are able to reduce the environmental impacts of building and selling our vehicles.

REFLECTION

The Japanese word *hansei*, translated loosely as reflection, is what happens when one of our employees stops to examine a completed project. *Hansei* is both an intellectual and emotional introspection. The employee must recognize the gap between the current situation and the ideal, take responsibility for finding solutions, and commit to a course of action. When a project finishes at Toyota, we use *hansei* to evaluate what went well and what did not. We then methodically try to preserve what went well and create countermeasures for what did not. These lessons are incorporated into the standard process so that when we repeat it, we improve over the last time. Finally, we share these insights with our colleagues so that they can learn as well, in a process we call *yokoten*.

SUPPLIERS

Toyota recognizes that environmental impacts extend into our supply chain. We have a vast network of suppliers providing us with everything from parts and accessories, to waste management and cafeteria services and office supplies. We work closely with our suppliers to share our knowledge and experience to help them improve their environmental performance.

We facilitate “treasure hunts” with interested suppliers to help them identify ways to reduce their energy use. The concept of *hansei*, or reflection, plays a major role in the success of these activities. Part of the treasure hunting process is to first reflect on current energy performance and to judge the successes and failures of past projects. *Hansei* leads to a more focused investigation of potential energy-saving opportunities.

Participating suppliers agree to host and allow other suppliers to enter their facility for the treasure hunts, which are conducted from Sunday to Monday to ensure participants see the plant in its rest, start up and production modes. Treasure hunt participants receive training, access to Toyota’s energy tools and support from the engineering team on investigating and designing energy reduction projects.

PERFORMANCE

Toyota has shared its energy treasure hunt process with 180 Tier 1 (direct) suppliers to date. Since the program began in 2008, annual savings of over 43 million kilowatt-hours—equivalent to 14,600 metric tons of CO₂ per year—have been identified during 40 supplier treasure hunts. The Bluegrass Automotive Manufacturer’s Association (BAMA) has commended Toyota for its leadership and strongly encourages its members to participate as both hosts and attendees in all Toyota-led treasure hunts.

RELATED TOPICS

- For more information about how we use treasure hunts and implement other *kaizens* to improve our own energy performance, please visit [**Eco-Efficient Operations/Energy & Greenhouse Gases**](#).
- For information about how we encourage our suppliers to implement environmental management systems, please visit [**Vision and Action/Environmental Management & Compliance**](#).

PARTNERSHIP: TOYOTA AND SODEXO PROMOTE LOCAL FOOD CHOICES

Toyota partners with Sodexo, a leading provider of integrated food and facilities management services in North America, at two cafeterias at its Torrance, California, campus. Sodexo is supporting local farmers while helping Toyota associates (as our sales and logistics employees are called) eat better and learn about health and wellness through “Meatless Mondays” and “Meet the Farmer” events.

Meatless Mondays encourage associates to cut out meat one day per week and instead try a plant-based diet. Signs highlight the day’s vegetarian options from each of the various serving stations. Meat dishes are still offered, but it is the vegetarian items that receive heavy promotion. By serving options such as garden burgers, eggplant and tofu, and grilled vegetable and hummus sandwiches, Sodexo seeks to educate customers about the benefits of eating healthier, including weight management, lowering cholesterol and getting more antioxidants from fruits and vegetables. The number of Toyota associates going meatless on Mondays has increased vegetarian purchases by over 15 percent.



Sodexo, one of our business partners, is supporting local farmers while helping Toyota associates at our U.S. sales headquarters campus eat better and learn about health and wellness through “Meatless Mondays.” Posters such as this one highlight the day’s vegetarian options and educate customers about the benefits of eating healthier.

Twice per month, Sodexo hosts “Meet the Farmer” events as a way of supporting local farms. A “local” farm is located within 200 miles. So far, 20 local farmers have been featured in Toyota’s Torrance cafeterias. Sodexo creates informational posters to describe the farm, its crops and its farming methods. Rising C Ranch, for example, is a family-owned farm with more than 130 acres of specialty citrus crops. The fruit is produced using sustainable methods and is harvested at the peak of flavor so that customers can enjoy the citrus at its best.

Produce from local farmers is available at a farmers’ market, where Sodexo chefs buy produce to serve in Toyota’s Torrance cafeterias. The chefs coordinate the menus according to what’s available at the farmers’ market. In addition, Sodexo, in collaboration with its sourcing partner, Freshpoint, is helping to bring an increasing amount of local, seasonal and sustainable food to Toyota associates. Thanks to these efforts, Toyota associates have a number of healthy and fresh food choices every day.



Chefs from Sodexo, our food services partner at our U.S. sales headquarters campus, shop at farmers' markets weekly. They coordinate menu options with what's available at the farmers' market. Sodexo is helping to bring increasing amounts of local, seasonal and sustainable food to our tables.



DEALERSHIPS

There are approximately 1,850 Toyota and Lexus dealerships in the United States, Canada and Mexico. These dealerships are all independently owned franchises. Since they are our face to the customer, it is important we share our know-how and environmental values with our dealerships and support their efforts to be environmentally responsible.

We work closely with our dealerships to promote green building practices, since buildings—both residential and commercial—have a large environmental footprint. Buildings are responsible for about one-third of the energy consumed in the United States and Canada. Green buildings can reduce energy use and associated greenhouse gas emissions by 25-60 percent, water use by 30-95 percent, and solid waste by 50-95 percent, and they have been shown to improve employee health and productivity.

Both our Toyota and Lexus divisions have programs to work with dealers on new construction and remodeling projects that encourage sustainable building practices and the use of the Leadership in Energy and Environmental Design (LEED®) rating system. LEED is a point-based system that promotes a whole-building approach to sustainable construction and remodeling. LEED certification is based on meeting stringent evaluations in sustainable site development, water savings, energy efficiency, materials selection and indoor air quality.

We have been working on LEED projects with our dealers for several years now. After each project, we reflect on what worked and what didn't and on what could be improved going forward. This process, known as *hansei*, ensures our learning informs the next generation of dealers seeking LEED certification.

A study performed on LEED-certified Toyota dealerships shows the average dealer who completes the LEED process is saving 26 percent on their energy costs per square foot per year. The often rapid return on investment for environmentally sustainable materials, energy-efficient lighting fixtures and other LEED elements confirms the economic benefit of building green.

In addition to supporting our dealerships with green building and LEED certification, we continue to educate our dealers about complying with applicable environmental regulations and standards. We maintain the C.L.E.A.N. Dealer website (Community Leadership Environmental Assistance Network), which includes environmental, health and safety resources as well as hazardous materials information. We also continue to require HazMatU, an industry dealer training program on hazardous materials transportation, for our Toyota and Lexus dealerships. And, we continue to offer the Toyota Recycling and Environmental Awareness (TREA) program, an online voluntary nonhazardous waste recycling program for U.S. dealers.

PERFORMANCE

We are leading the industry with the number of dealerships that are certified to LEED. We have assisted 26 Toyota and Lexus dealerships in the United States and Canada with LEED certification: 20 Toyota dealerships and four Lexus dealerships in the U.S., and two Toyota dealerships in Canada. Twelve more dealerships have completed construction and are waiting for their ratings to be decided. Many more are under construction or in the design and permitting phase and have registered their intent to pursue LEED with the U.S. or Canadian Green Building Councils. In the United States, Toyota dealerships have a combined 1.4 million square feet of LEED-certified building space.

“Toyota and Lexus dealers have truly seized the opportunity to ‘green’ their businesses,” said Ernest Bastien, Vice President of Retail Market Development at Toyota Motor Sales, U.S.A., Inc., “and by doing so are demonstrating environmental leadership in their communities. Dealers are also quickly recouping their initial investments and realizing the long-term financial benefits of building more efficient dealerships.”

We also have a number of dealerships, such as Jim Hudson Lexus of Columbia, South Carolina, that chose not to pursue LEED but still employ a number of sustainable strategies during new construction, expansion and remodeling projects.

FG26 • North American Toyota and Lexus Dealerships With LEED Certifications

DEALER NAME	LOCATION	YEAR CERTIFIED	CERTIFICATION LEVEL
Alamo Toyota	San Antonio, Texas	2012	Silver
Sun Toyota	Holiday, Florida	2012	Gold
Vancouver Toyota	Vancouver, Washington	2012	Silver
Bennett Toyota	Allentown, Pennsylvania	2012	Gold
Toyota of the Black Hills	Grand Forks, South Dakota	2012	Silver
Maguire Toyota	Ithaca, New York	2012	Platinum
Toyota Scion of Bend	Bend, Oregon	2011	Gold
Beaman Toyota	Nashville, Tennessee	2011	Certified
Legends Toyota	Kansas City, Kansas	2011	Gold
Lexus of Henderson	Henderson, Nevada	2011	Gold
Stouffville Toyota	Stouffville, Ontario, Canada	2011	Gold
Dave Mungenast Lexus of St. Louis	St. Louis, Missouri	2010	Silver
Grossinger City Toyota	Chicago, Illinois	2010	Silver
James Toyota	Flemington, New Jersey	2010	Silver
Jerry Durant Toyota	Granbury, Texas	2010	Silver
Kendall Toyota	Eugene, Oregon	2010	Platinum
Stratford Toyota	Stratford, Ontario, Canada	2010	Gold
Toyota of El Cajon Certified Center	Santee, California	2010	Gold
Toyota of El Cajon	El Cajon, California	2010	Silver
Caldwell Toyota	Conway, Arkansas	2009	Gold
Fitzgerald’s Lakeforest Toyota	Gaithersburg, Maryland	2009	Gold
Lexus of Las Vegas	Las Vegas, Nevada	2009	Gold
Mark Miller Toyota	Salt Lake City, Utah	2009	Gold
Sewell Lexus Pre-Owned	Fort Worth, Texas	2009	Gold
Toyota of Rockwall	Rockwall, Texas	2008	Gold
Pat Lobb Toyota	McKinney, Texas	2007	Silver

RELATED TOPICS

- For information on Toyota's green building practices, please see [Eco-Efficient Operations/Green Building](#).
- Watch a short video about a TOYOTA dealership's achieving LEED GOLD certification.

SPOTLIGHT: STOUFFVILLE TOYOTA

Stouffville Toyota in Stouffville, Ontario, is the second Toyota dealership in Canada to earn LEED certification from the Canadian Green Building Council. Stouffville earned the highest LEED point total of any Canadian automotive dealership. The dealership, situated in the environmentally sensitive Oak Ridges Moraine, incorporated several special design initiatives to achieve LEED Gold, including:

Water Savings

- Cisterns have been installed to collect rainwater that flows into plumbing fixtures and irrigation systems.

Energy Efficiency

- A sophisticated photovoltaic system that traces the sun throughout the day maximizes on-site solar power.
- Over 85 percent of occupied areas (including service bays) are exposed to natural light to reduce the need for artificial lighting.
- In-floor radiant heating was installed throughout the building.

Indoor Air Quality

- In addition to leading-edge air quality management programs, low-VOC (volatile organic compound) adhesives, sealants, paint, carpet, wood and laminates were used in construction.

Materials

- During construction, about 75 percent of all waste was diverted from landfills and sent for recycling, and more than 25 percent of building materials were composed of recycled content.
- To reduce pollution from long-distance shipping, 38 percent of building materials came from the region.
- About half of all wood products were harvested from forests managed by the Forest Stewardship Council.

Sustainable Development

- Preferred parking is available for hybrid and alternative fuel vehicles, while bicycle storage and change rooms are provided to encourage "people-powered" transportation.

These strategies resulted in a 71 percent reduction in overall energy use compared to standard energy codes, and an 83 percent reduction in water consumption.

In keeping with Stouffville Toyota's mission to use its facility to foster environmental awareness and education in the local community, the Gold certification was commemorated by bringing about 100 elementary school students to the dealership to celebrate Earth Day in 2012. The students, who attend Summitview Public School and Roy H. Crosby Public School, were joined at the event by Wayne Emmerson, Mayor of Whitchurch Stouffville.

The children were offered a tour of the building, including its 9,300-square-foot showroom and 14 service bays. They also had the treat of getting inside a Toyota Prius Plug-in Hybrid and interacting with the Toyota rally racers who had recently returned from Monte Carlo after placing 21st in the world's most prestigious green rally.

RELATED TOPICS

- For more information on the Prius Plug-in's performance at recent green rallies, please visit [**Green Innovation/Future Transportation/Plug-in Hybrid Vehicles/Green Rallies**](#).

SPOTLIGHT: LEXUS OF HENDERSON

The Lexus of Henderson dealership in Henderson, Nevada, is the third Lexus dealership to achieve LEED Gold certification. Sustainable strategies for LEED Certification include:

Water Reduction

- Water-efficient flush and flow plumbing fixtures were installed.
- Drip irrigation for native and adapted plants was installed.

Energy Efficiency

- Energy-efficient lighting and day lighting were utilized to reduce lighting loads and improve working conditions for the occupants.
- The building roof and hardscape are designed to minimize contribution to the heat island effect, thereby reducing the energy required to cool the building.

Indoor Air Quality

- Low emitting VOC finishes and materials were used throughout the dealership.

Materials

- Products and materials with high levels of recycled content were used throughout the dealership.
- Wood certified by the Forest Stewardship Council was selected for millwork and furniture.
- Over 85 percent of construction waste was recycled.

These strategies resulted in energy use savings of 38 percent and fixture water reduction of 42 percent. This facility also has a Build-out Manual so that future expansion and construction will meet the LEED requirements for materials, indoor air quality, water use and energy efficiency.



Lexus of Henderson in Nevada is the third Lexus dealership to receive LEED Gold certification. Thanks to a number of green building strategies, this dealership has reduced energy use by 38 percent and water use by 42 percent.

TOYOTA | 2012

NORTH AMERICAN ENVIRONMENTAL REPORT

STRENGTHENING COMMUNITIES

- > SIGNATURE PARTNERSHIP:
NATIONAL AUDUBON SOCIETY
- > ENVIRONMENTAL STEWARDSHIP
- > ENVIRONMENTAL EDUCATION
- > LOCAL COMMUNITY
ENGAGEMENT

Strengthening Communities is a chapter in the Toyota 2012 North American Environmental Report. Read the entire report online at Toyotaenvironmental.com or scan the QR code to access the report with your mobile device.





To watch a short video about how TOYOTA and AUDUBON are making a difference through TOGETHER GREEN on your mobile device, scan the QR code below.



> STRENGTHENING COMMUNITIES

At Toyota, we believe an auto company can also be a vehicle for change. That's why we support programs focused on environmental initiatives that help strengthen diverse communities across North America.

Our support is focused in two key areas: *environmental stewardship*—helping to conserve resources and protect nature, and *environmental education*.

Our support in these key areas stems from Toyota's Guiding Principles and Earth Charter, which encourage us to contribute to the development of local communities by building close and cooperative relationships. The partnerships we develop with universities, nonprofits and community organizations are an integral part of our commitment to the environment. We help create programs that support our corporate values of respect for people and growth in harmony with nature.

Our corporate values are grounded in the Toyota Way. Practicing the Toyota Way helps us build more than quality vehicles; it also help us develop strong, lasting partnerships. The concept of *hansei*, or reflection, is important to the success of our philanthropic programs. *Hansei* teaches us to examine the programs we support closely to determine where the need is greatest, which initiatives were successful and which could be improved. We give our partners our expertise and our time to make every relationship the best it can be.

Toyota has contributed millions of dollars, countless vehicles and hundreds of thousands of volunteer hours to help conserve and protect the environment in North America. The impact of our programs has local, national and even international reach. We describe a number of our partnerships below.

REFLECTION

The Japanese word *hansei*, translated loosely as reflection, is what happens when one of our employees stops to examine a completed project. *Hansei* is both an intellectual and emotional introspection. The employee must recognize the gap between the current situation and the ideal, take responsibility for finding solutions, and commit to a course of action. When a project finishes at Toyota, we use *hansei* to evaluate what went well and what did not. We then methodically try to preserve what went well and create countermeasures for what did not. These lessons are incorporated into the standard process so that when we repeat it, we improve over the last time. Finally, we share these insights with our colleagues so that they can learn as well, in a process we call *yokoten*.

SIGNATURE PARTNERSHIP: NATIONAL AUDUBON SOCIETY

In 2008, Toyota and the National Audubon Society launched *TogetherGreen*[™], a program funded by a \$20 million grant from Toyota. The *TogetherGreen* program trains Fellows to be the environmental leaders of tomorrow, awards Innovation Grants to fund conservation projects across the United States, and supports Volunteer Days to offer individuals an opportunity to give back to their communities.

TogetherGreen has fostered diverse partnerships involving organizations, communities and people from all walks of life. To date, *TogetherGreen* has funded more than 1,500 partnerships between organizations such as public and private schools and universities, corporations, foundations, Native American Tribes, community service and faith-based organizations, and local, state and national parks and agencies. The program has also trained 400 conservation leaders—people from varied backgrounds such as educators, scientists, military veterans and artists, to name a few—who in turn have mobilized more than 310,000 people to reduce energy use, protect wildlife habitat and improve water quality in every state in America.

Since 2008, nearly 900 volunteer events have taken place across the country involving more than 36,000 volunteers, including Toyota employees in New York, Kentucky, Indiana, Missouri, Texas and California. *TogetherGreen* volunteers have given over 333,000 hours to plant more than 135,000 trees and shrubs and improve or restore almost 13,000 acres. The value of the volunteer hours alone is estimated to be \$6.9 million.

Many of the projects funded through *TogetherGreen* are featured in a new campaign called “Exit the Highway.” Toyota and the National Audubon Society teamed up this past summer to ask Americans to “Exit the Highway” and drive the scenic route to discover natural wonders. The campaign highlighted nearly 100 nature destinations in more than 60 cities and encouraged people to visit Audubon centers, *TogetherGreen* conservation projects, Toyota’s plants in Kentucky and Texas, and favorite nature spots recommended by Toyota’s own dealers, executives and engineers. For every pledge to Exit the Highway and for every photo of a nature stop shared online, participants were entered to win a Toyota Prius v. Over 48,000 people entered; the winner of the Prius v was Tony Riddle from Cincinnati, Ohio.

In November of 2011, Toyota received the **Keesee Award** for its support of the *TogetherGreen* program. Audubon New York established the Keesee Award in 2001 to honor individuals whose contributions, talent and commitment to the environment have advanced conservation and environmental education. For more information on *TogetherGreen*, please visit www.togethergreen.org.

INNOVATION GRANT SUPPORTS LIGHTS OUT MINNEAPOLIS

Over 350 species of birds travel along the so-called “Mississippi Flyway,” which meanders through some of the most beautiful wild lands and farmland in the United States. Hundreds of millions of birds are killed when they fly into windows in the U.S. each year. Audubon Minnesota has documented mortality in over 100 species along the Mississippi Flyway alone. Using this research, they have created a plan to combat unnecessary bird fatalities.

One simple solution is to turn off building lights at night. With their *TogetherGreen* Innovation Grants, Audubon Minnesota has worked with building owners and the government to convince building managers to turn off their lights at night. Currently, 59 of the brightest buildings on the Minneapolis and St. Paul skylines have “signed-on” to Lights Out and are turning off their lights after midnight during both spring and fall migration. As a result of Lights Out Minneapolis, new legislation was passed requiring all state-owned and leased buildings in the state of Minnesota to turn off their lights at night.

To further expand their message, Audubon Minnesota is also targeting an audience of over 400 building owners, managers, designers and architects about the issue, using Bird-Safe Building Guidelines. New York City Audubon and the City of Toronto are partners in helping to replicate these design guidelines in their cities.

TOGETHERGREEN FELLOW DANNI WASHINGTON

Daniell “Danni” Washington, a graduate of the University of Miami, founded the Big Blue & You Foundation in 2009 to educate and empower youth to become stewards of this planet through service learning, visual arts and media. In 2010, Danni became Director of the One Water Workshop, a five-day filmmaking workshop created by the Miami World Cinema Center (the first nonprofit film studio), where high school students create public service announcements about water conservation issues.

As a *TogetherGreen* Fellow, Danni plans to expand the Big Blue & You Foundation and the One Water Workshop deeper into Miami’s urban community to reach at-risk high school students. Selected at-risk high school students will have the opportunity to participate in this five-day intensive training program that completely immerses students in the process of video pre-production, production and post-production. Students will come away with finished public service announcements about Florida aquatic resources, and they will serve as leaders for a school-wide service project with the Reclamation Project, restoring mangrove, fresh water and tropical hardwood hammock areas in Miami-Dade County. In addition, Danni plans to launch an innovative online video series featuring local youth who are passionate about marine life to encourage the community to take simple steps to protect the oceans.

By connecting inner city youth to the beauty and necessity of Florida’s aquatic resources, she believes it will increase the chances of improving local water quality in South Florida, which will ultimately protect the biodiversity that makes Florida so unique. This 24-year old marine biologist, world traveler and environmental advocate will continue to focus her energy on using any creative medium to encourage today’s young generation to love our natural environment, ultimately ensuring a bright and sustainable future.

“It is tremendously empowering to have the support of Toyota and Audubon Society as a *TogetherGreen* Fellow,” says Danni Washington. “Just knowing that these global entities are willing to invest in the efforts of grassroots environmental leaders encourages me to work harder and inspire more Miami youth to protect our water resources.”



TogetherGreen Fellow Danni Washington is one of The Grio’s 100 people making history today and having a positive impact on the African-American community. She plans to expand the Big Blue & You Foundation and the One Water Workshop deeper into Miami’s urban community to reach at-risk high school students.

TheGrio.com, a video-centric news community, selected Danni Washington as one of The Grio’s 100, a list of 100 people making history today and having a positive impact on the African-American community. Danni was one of 10 people chosen in the Science and Environment field for her achievements, including her *TogetherGreen* fellowship.

RELATED TOPICS

- Watch a short video about TOYOTA and AUDUBON making a difference through TOGETHER GREEN.

ENVIRONMENTAL STEWARDSHIP

ARBOR DAY FOUNDATION

In 2008, Toyota and the Arbor Day Foundation launched Tree Campus USA, a program that recognizes college campuses that commit to five environmental standards to promote tree care and community outreach. So far, 116 distinguished schools have received the Tree Campus USA designation.

Alpha Phi Alpha Fraternity, Inc. and Alpha Kappa Alpha Sorority, Inc. are working in partnership with the Arbor Day Foundation to launch an aggressive campaign to encourage sustainability and tree planting at Historically Black Colleges and Universities across the country. Alpha Phi Alpha and Alpha Kappa Alpha are teaming up to help collegiate members become environmental leaders on their respective campuses and ultimately achieve Tree Campus USA recognition from the Arbor Day Foundation. The campaign entails planting trees on seven campuses: Kentucky State University, Wilberforce University, Morehouse College, Spelman College, the University of South Florida, Texas Southern University and Hampton University. Toyota will support five of these tree-planting events, in addition to the 10 events already held each year on Tree Campus schools.

During 2011, the Arbor Day Foundation and Toyota helped campuses throughout the country plant 30,000 trees. Tree Campus USA colleges and universities have invested more than \$22 million in campus forest management.

EVERGREEN LEARNING GROUNDS

Toyota in Canada and its dealerships have partnered with Evergreen for over a decade, working together to transform Canadian school grounds into natural learning environments. In mid-2012, Toyota and Evergreen celebrated an important milestone: The Evergreen Learning Grounds program reached its one millionth Canadian child.

The Toyota Evergreen Learning Grounds program offers students a close, hands-on relationship with the natural world while educating them about the importance of restoring, protecting and celebrating it. In the process, students transform their traditional school grounds—often a combination of asphalt and turf—into natural learning spaces featuring trees, wildflowers and shaded areas.

The Toyota Evergreen Learning Grounds Program offers schools access to landscape design expertise and a resource library featuring how-to guides and information on native plants. It also provides interactive workshops for teachers and others to show them how they can weave the natural space into their curriculum.

Since the program's inception, almost 6.7 million people have benefitted from a Toyota Evergreen Learning Grounds project. Nearly 80 percent of Toyota dealers across Canada are partnered with schools in their local communities. Frenchman's Bay Public School is one of six schools in the Durham Region to benefit from the program in the 2011/2012 school year. Grade four students play and learn in three naturalized areas, including a shady grove and two outdoor classrooms built with two-year funding support from the local dealership, Pickering Toyota.

HOUSEHOLD HAZARDOUS WASTE COLLECTIONS

Several of Toyota's North American locations host household hazardous and electronic waste collections for employees and surrounding communities as part of Earth Day celebrations. These collections ensure proper recycling or disposal for household items such as appliances, cell phones, paint, batteries, pesticides, automotive fluids, furniture stains and bathroom cleaners. Some sites have added clothing and toys to their collection days and donate these to Goodwill. The following Toyota locations hosted a collection event in 2012:

- Plant in Georgetown, Kentucky
- Plant in Princeton, Indiana
- Plant in Huntsville, Alabama
- Plants in Cambridge and Woodstock, Ontario
- Canadian sales headquarters in Toronto, Ontario
- U.S. sales headquarters in Torrance, California
- Parts distribution center in Torrance, California
- Parts center in Ontario, California
- Vehicle distribution center in Long Beach, California

Together, we collected approximately 140,000 pounds of material during these events either for donation or for proper recycling and disposal. Our Georgetown, Kentucky, plant has been hosting "SupeRecycling Day" since 1994, and has collected and recycled nearly 300 tons of electronic and household hazardous waste.

These events demonstrate how Toyota extends its commitment to waste reduction beyond its production activities. "Providing this service is a way for Toyota to show its appreciation to the community," Georgetown plant President Wil James said. "We all have to do our part. And when we do, we make a difference well beyond our own backyard."

RELATED TOPICS

- For information on our own recycling and waste minimization efforts, please see [**Eco-Efficient Operations/Waste Minimization**](#).

NATIONAL PUBLIC LANDS DAY

For the 14th year, Toyota sponsored National Public Lands Day (NPLD) in partnership with the National Environmental and Education Foundation (NEEF). This national program, held annually in September, is the largest hands-on volunteer event to improve and enhance public lands.

In addition to providing sponsorship, Toyota encourages employees to get involved in NPLD activities by volunteering in their local parks, forests, rivers, beaches, shorelines and other public lands. During NPLD 2011, more than 3,100 Toyota employees volunteered at 40 different sites in 20 states and U.S. territories.

In fact, more than 400 Toyota team members from our new plant in Blue Springs, Mississippi, celebrated NPLD in 2011 by working together to clean and protect five sites. At Natchez Trace Parkway, volunteers cleaned the area and its buildings and removed invasive weeds to preserve native plants. At Carver Elementary School, Toyota volunteers weeded and mulched the school's rock garden, painted railings and removed brush, while at Tupelo High School debris from the school's grounds was removed. At Oren Dunn Museum, volunteers washed antique fire trucks and added siding to a barn.



Natchez Trace Parkway is one of five sites in Tupelo that team members from our Mississippi plant helped to clean up as part of National Public Lands Day. More than 400 team members volunteered their time that day to help their community clean and protect public lands.

During NPLD 2011, more than 170,000 volunteers maintained 1,500 miles of existing trails, beautified stream beds, removed trash and invasive plants, and planted an estimated 100,000 trees, shrubs and native plants. These projects contributed an estimated \$17 million in improvements to federal, state and local public lands. For more information, please visit www.PublicLandsDay.org.

FG27 • National Public Lands Day 2011, Toyota Site List

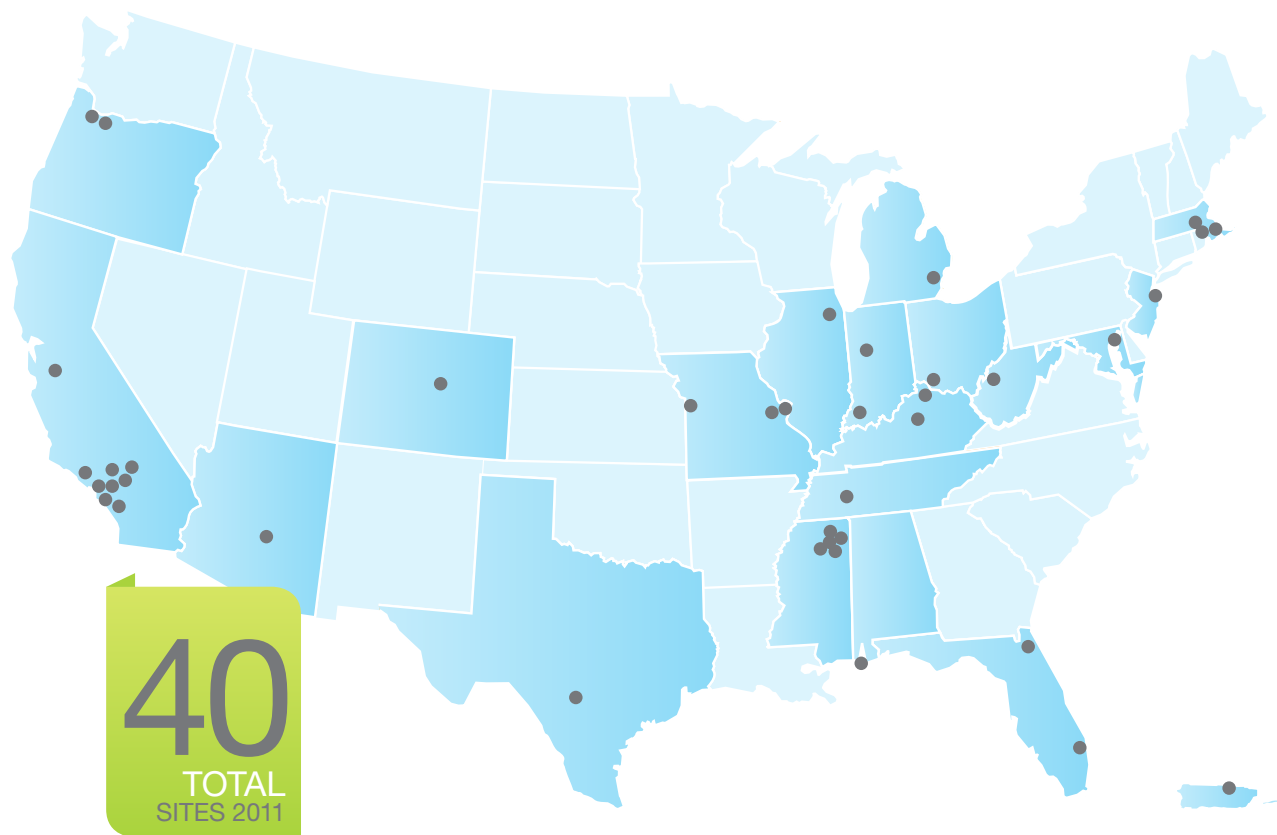

ALABAMA

Dauphin Island Beach,
Dauphin Island

ARIZONA

Tonto National Forest
Lower Salt River,
Pebble Beach
Recreation Area, Mesa

CALIFORNIA

Audubon Least Tern
Colony, Venice
Cabrillo Marine
Aquarium, San Pedro
El Dorado Nature Center,
Long Beach
Irvine Ranch
Conservancy, Irvine
Mt. Diablo State Park,
Live Oak Campground,
Clayton
Lytle Creek, San
Bernadino National
Forest, Lytle Creek
Santa Fe Dam
Recreational Area,
Irwindale
Shipley Nature Center,
Huntington Beach

White Point Nature
Center, San Pedro

COLORADO

Red Rocks Park,
Geologic Overlook
Area, Morrison

FLORIDA

Deerfield Beach,
Deerfield Beach
Talbot Island State Park,
Jacksonville

ILLINOIS

Dick Young Forest
Preserve, Batavia

INDIANA

Armstrong Park,
Lafayette
Scales Lake Park,
Boonville

KENTUCKY

Big Bone Lick State Park,
Union
Salato Wildlife Education
Center, Frankfort

MARYLAND

Fort McHenry National
Monument and
Historic Shrine,
Baltimore

MASSACHUSETTS

Buffumville Lake,
Charlton
Oak Knoll, Attleboro
West Hill Dam, Uxbridge

MICHIGAN

Belle Isle, Detroit

MISSISSIPPI

Carver Elementary
School, Tupelo
Natchez Trace Parkway,
Tupelo
Oren Dunn Museum,
Ballard Park &
Sportsplex, Tupelo
Trace State Park, Belden
Tupelo High School,
Tupelo

MISSOURI

Cuivre River State Park,
Troy

Eco Park, Saint Charles
Smithville Lake, Smithville

NEW JERSEY

McCarter Park, Denville

OHIO

Blue Ash Park, Blue Ash

OREGON

Cathedral Park, Portland
Harbor, Portland
Columbia Children's
Arboretum, Portland

PUERTO RICO

Isla de Cabras
Cataño, Puerto Rico

TENNESSEE

Jackson City Beautiful,
Jackson

TEXAS

Mitchell Lake Audubon
Center, San Antonio

WEST VIRGINIA

Town of Buffalo Library,
Buffalo

In addition to sponsoring NPLD, Toyota will contribute \$3 million over the next three years to NEEF for the “Every Day Grants” program to improve the capacity of local organizations and “friends groups” that support public lands everyday. The grant comes at a time when public lands are in critical need of financial and volunteer support.

NEEF and Toyota’s support for public lands serves as an excellent example for public-private partnerships, which are key to lasting conservation solutions for our nation. Such partnerships also support the goals of America’s Great Outdoors initiative, a grassroots approach to protecting lands and waters and connecting all Americans to their natural and cultural heritage.

“Thousands of local nonprofit organizations are answering the call to help their public lands maintain grounds and trails, and generally keep up with growing interest in their use locally and nationally,” said Diane Wood, president of NEEF. “But many groups lack the necessary resources to be as effective as they possibly can. Toyota’s gift unleashes the power of these groups to serve their local parks and lands by increasing their capacity to establish lasting organizations, recruit volunteers and involve their communities.”

WATERKEEPER ALLIANCE

Founded in 1999 by environmental attorney and activist Robert F. Kennedy, Jr. and several veteran Waterkeeper Organizations, Waterkeeper Alliance is a global movement of on-the-water advocates who patrol and protect over 100,000 miles of rivers, streams and coastlines in North and South America, Europe, Australia, Asia and Africa. In 2011, Toyota provided a \$200,000 grant to support the SPLASH Event Series. SPLASH is a national recreational event series that raises awareness of the importance of waterways.

The SPLASH Series takes place on five waterways around the United States, and each of the SPLASH events raises funds to support Waterkeeper Alliance and its local Waterkeeper organizations by engaging local citizens and clean-water enthusiasts in water-based activities like swimming, paddling and boating. The first season of SPLASH events kicked off with the Hackensack River Paddle in October of 2011 in Hackensack, New Jersey. Events have also been held in Santa Monica, California; Miami, Florida; Charleston, South Carolina; and Washington, D.C.

WYLAND FOUNDATION

Since 2009, Toyota has supported the Wyland Foundation, a nonprofit founded by renowned marine artist Wyland that helps children and families across the United States recognize the importance of healthy oceans and waterways. This year, Toyota and the Wyland Foundation celebrated the 40th anniversary of the Clean Water Act by launching the first National Mayor’s Challenge for Water Conservation. With support from the U.S. Environmental Protection Agency and a number of other organizations, the campaign challenges mayors nationwide to inspire their residents to conserve natural resources by taking a free, online pledge to save water during Earth Month.

Nearly 20,000 people from 1,000 cities in all 50 states made online pledges to save a total of 4.7 billion gallons of water over the next year, with a potential cost savings of \$11.6 million. Residents further pledged to reduce their use of single-use plastic water bottles by 1.1 million bottles and eliminate 60,000 pounds of waste from entering watersheds.

Laguna Beach, California, resident Nika Shalala was the grand prize winner of the 2012 National Mayor's Challenge. Shalala became eligible for the grand prize drawing after Laguna Beach was named among the 12 winning cities for the Mayor's Challenge. As the grand prize winner, Shalala received a new Toyota Prius *c*. "We congratulate Nika for being this year's grand prize winner," said artist and environmentalist Wyland, who spearheaded the initiative. "With great support from partners like Toyota, we are able to expand the Mayor's Challenge nationally this year to generate awareness about the importance of conservation for protecting our environment, both for today and the future."

In addition to the grand prize of a Toyota Prius *c*, participants in the winning cities were eligible for prizes that included custom-designed sprinkler systems from Rain Bird, EcoFlow® Shower Heads from WaterPik, water-saving toilets from STERLING Plumbing, and 1,000 gift cards for Lowe's® Home Improvement Stores. Prizes worth more than \$50,000 were awarded.

2012 also marked the second anniversary of Toyota and Wyland's Earth Month Heroes, a Southern California program that recognizes 30 exemplary citizens who find ground-breaking ways to work toward sustaining a healthy planet. The Wyland Foundation, Toyota and regional broadcast partner KCBS/KCAL made donations of \$250 on behalf of the Earth Month Heroes to deserving organizations in Southern California, with a \$1,000 grand prize donation to Plug-in America®.

ENVIRONMENTAL EDUCATION

LEXUS ECO CHALLENGE

Lexus, in partnership with Scholastic, sponsors the annual Lexus Eco Challenge. Since the program was created, the Lexus Eco Challenge has awarded \$4 million in scholarships and grants to empower middle and high school students to learn about the environment and take action to improve it. The program entered its sixth year in 2012; more than 25,000 students have participated to date, learning how they can make a difference in the world around them.

In addition to the ongoing contest, the Lexus Eco Challenge provides educational materials designed by Scholastic that integrate creative lesson plans into the classrooms to help teach students about the environment. For each challenge, the website (www.scholastic.com/lexus) has lesson plans and teacher instructions including questions to help guide a discussion about the current challenge topic, facts about the topic, and guidelines for a specific classroom project.

In 2011, "The Green Musketeers" from Jericho High School in Jericho, New York, and the "One-Towel Wonders" from SCAPA Bluegrass in Lexington, Kentucky, were the Grand Prize winners. "The Green Musketeers" created their own filtration system with the goal of patenting it, selling it and using profits toward developing systems in third-world countries. The "One-Towel Wonders" demonstrated how a simple idea—using one towel per person, per week—would benefit the environment. For their efforts, each grand prize winner received \$30,000, of which the school received a grant for \$7,000, the teacher advisor got a \$3,000 grant, and the students shared \$20,000 in scholarships.

The eight First Place teams each won \$15,000 with \$3,000 for the school, \$2,000 for the teacher advisor and \$10,000 in scholarships for the students. The winning teams were:

- “Team Aqua,” Arboga Elementary School, Arboga, California
Raised money and awareness around the world for water conservation programs.
- “Carbonators,” Clark Magnet High School, La Crescenta, California
Used ArcGIS to analyze smog levels around the world and how smog impacts health.
- “The Trophic,” Miami Palmetto Senior High School, Miami, Florida
Focused on reducing carbon dioxide emissions through programs to benefit the land, air and water in their community.
- “WEACT,” Leilehua High School, Wahiawa, Hawaii
Launched an environmental awareness program in the community to culminate in the construction of a mural.
- “Purpledinowolficorns,” Tates Creek Middle School, Lexington, Kentucky
Developed a proposal to the mayor about involving the community to improve the city.
- “WMS Carbon Busters,” Whitehall Middle School, Whitehall, Michigan
Encouraged the school, community and state to pass on bottled water and drink tap water.
- “Environmental Discovery Project,” West Geauga High School, Chesterland, Ohio
Contacted international communities to encourage composting.
- “HMS Hawks,” Hanahan Middle School, Hanahan, South Carolina
Raised awareness of the benefits of eating locally grown produce.

“The Lexus Eco Challenge is an integral part of the environmental studies curriculum at SCAPA,” said Ashlie Beals, teacher advisor for the “One-Towel Wonders.” “For the past five years, all of my eighth grade students have worked in teams to create and implement innovative campaigns to encourage others to make one small change that can have a large positive impact on our environment. During the challenge, students sharpen their oral and written communication skills, utilize many forms of technology and work together actively and enthusiastically to solve real-life problems. My younger students eagerly look forward to their chance to participate in the challenge when they are in eighth grade. I can’t thank Lexus and Scholastic enough for offering this tremendous opportunity to my students.”

TOYOTA INTERNATIONAL TEACHER PROGRAM

The Toyota International Teacher Program is a fully-funded professional development program for U.S. secondary school teachers of all subjects. Administered by the Institute of International Education and fully funded by Toyota, the program is in its 13th year. Teachers participate in a two-week overseas study tour, during which they investigate environmental and educational themes through site visits, lectures, service projects and collaborative projects with local teachers. To date, more than 685 educators representing 47 states and the District of Columbia have completed study tours to the Galápagos Islands, Costa Rica, Japan and South Africa. Please see www.iie.org/toyota for more information.

The program supports and strengthens teachers' knowledge of environmental issues and their understanding of global conservation issues. Upon returning to their classrooms, teachers apply what they have learned to create interdisciplinary, solution-focused educational approaches. The teachers also participate in professional conferences, seminars and community workshops to share what they have learned. It is estimated that more than 650,000 students have benefited from these travel programs and expanded curriculums.

In November 2011, educators traveled to Costa Rica for the fifth time. During their travels to San Jose, Guacimo, Sarapiquí and La Fortuna, they participated in activities highlighting the relationship between Costa Rican history, culture and the environment. They toured sustainable agriculture projects at Earth University and engaged in service projects at La Selva Biological Station, one of the most studied tropical rain forests in the world. Area experts educated participating teachers on local development, agronomy and conservation practices. Other activities included studying research methods at Earth University and visiting rural Costa Rican primary and secondary schools to observe classes and interact with teachers and students. All activities were aimed at exploring the role of environmental education in spreading environmental awareness.



A group of educators traveled to Costa Rica in late 2011 as part of the Toyota International Teacher Program. The activities during this two-week study tour were aimed at exploring the role of environmental education in spreading environmental awareness.

Through the Toyota International Teacher Program, teachers are helping local communities find solutions to global problems, and their students are being exposed to a global experience that enhances their understanding of environmental issues in their own communities and around the world.

SPOTLIGHT: TITP ALUMNUS COMES FULL CIRCLE

During the trip to Costa Rica in 2011, educators were accompanied by 2009 Toyota International Teacher Program alumnus, Jason Shields. As an on-site Discussion Leader, Jason provided support and mentorship, and facilitated group debriefs to stimulate creative thinking among the participants.

“As a Discussion Leader, I had the opportunity to share and expand on the action plan that I developed from my first trip, and to inspire others to develop action plans that would change their classroom, school and community,” said Jason. “It was truly an honor and a privilege to be part of Toyota’s unique teacher professional development program for a second time.”

Jason teaches math and engineering at Kings High School in South Lebanon, Ohio. His goal is to help produce the next generation of green engineers and inventors by placing his students at the forefront of green technologies and sustainable engineering. Upon his return from the program in 2009, he gathered a team of eight students to participate in the Lemelson MIT InvenTeams competition. His team was selected as one of 14 teams across the nation to receive a \$10,000 grant for their idea to create backpack hydro-electric generators for people in developing countries.

Jason has created a new engineering program at Kings High School. His students are acting as small engineering firms. They are developing solutions to problems using funding from budgets approved by the school board. As a result of his students’ projects, the school district installed water refilling stations around the school, saving tens of thousands of plastic water bottles from ending up in landfills. His students also developed a Java™ program that transfers electric, water and gas meter data to the district’s online ENERGY STAR® Portfolio to help the district monitor and conserve resources.

“The Toyota International Teacher Program has been instrumental to me during the creation of my new engineering program at Kings High School,” said Jason. “Both of my trips to Costa Rica have offered a true paradigm shift resulting in the development of new lessons and projects for my school and community.” Jason’s students will be piloting a new program, inspired by the Dean of Engineering at the University of Cincinnati, to complete their freshman year as engineering majors while still in high school. The students will earn transcript credit for engineering, math, English and physics while at Kings High school, allowing them to earn their entire engineering masters degree and coop experience within four years after high school.



Jason Shields (right) teaches math and engineering at Kings High School in South Lebanon, Ohio. During his second trip to Costa Rica with the Toyota International Teacher Program, Jason served as a Discussion Leader. His students and his community have benefited greatly from his experiences with this program.

LOCAL COMMUNITY ENGAGEMENT

Toyota partners with numerous local community organizations where we live and work. These partnerships allow our employees to volunteer in their communities and share their knowledge and expertise.

Toyota is proud of the volunteering and philanthropy of its employees across North America. Our employees take what they learn about energy saving, water conservation and recycling, and apply these practices at home and in their communities. Our employees embody our **Action Guidelines**, which direct us to always be concerned about the environment and to actively participate in our communities.

Here are just a few examples of how we engage with our local communities:

- In honor of United Nations' World Water Day, the Water Environment Federation and the International Water Association announced Toyota Motor Manufacturing Indiana was one of two North American recipients of the third annual **Water Champion awards**. Initiated in 2009, the Water Champions awards recognize program participants for outstanding achievement in boosting awareness of water quality issues through involvement in the World Water Monitoring Challenge™ (WWMC). Winners were chosen by a subcommittee of the WWMC regional panel of judges, comprised of water industry professionals from around the world. Toyota partners with Gibson, Vanderburgh and Warrick county schools to share the WWMC program with sixth-grade science students and annually involves more than 2,200 students in the program. More than 10,500 area students have participated in the program since 2004. Program participants sample about 100 different lakes, rivers and streams across southwestern Indiana. Monitoring data then is uploaded into the WWMC database.



Team members from our plant in Princeton, Indiana, worked with sixth graders from Gibson, Vanderburgh and Warrick county schools to sample water bodies during World Water Monitoring Day. In recognition of this work, our Indiana plant received a Water Champion award.

- Toyota’s research and development center in Michigan has been partnering with Habitat for Humanity for the past four years. In 2011, 144 volunteers gave 1,152 hours of their time to provide a hardworking and deserving family the opportunity to own a home. They worked on a bungalow-style home in Ypsilanti to install new siding, windows, doors, drywall, cabinetry and flooring. The house was renovated to achieve an ENERGY STAR® five star rating, which will save the new homeowners thousands of dollars in energy and water costs. On average, Toyota’s renovations have been 40 percent more energy-efficient than a brand new home, which keeps an estimated 4,500 pounds of greenhouse gases out of the atmosphere annually. Toyota’s partnership with Habitat for Humanity is also active in Canada, where two teams of volunteers worked on homes in Toronto built to R-2000 standards. R-2000 is a voluntary performance standard for energy efficiency, indoor air quality and environmental responsibility administered by Natural Resources Canada.
- During Earth Week, 25 employees from Toyota’s Canadian sales headquarters ventured into their local communities for “20 Minute Makeovers” of a nearby ditch, a ravine and a playground. They collected 44 bags of trash.



In honor of Earth Week, employees from Toyota’s Canadian sales headquarters gave a “20 Minute Makeover” to a nearby ditch. They collected 44 bags of trash.

- Hundreds of young people from across West Virginia attended the 49th annual state Youth Environmental Day on May 19, 2012 at North Bend State Park. The popular event is sponsored by the West Virginia Department of Environmental Protection and several corporations including Toyota of West Virginia. Youth group members received awards from George Vickers, an Environmental Specialist at Toyota’s West Virginia plant, for their participation in community environmental projects, including litter cleanups, recycling drives, school landscaping projects, tree planting, backyard composting, wildlife management, watershed protection and much more. George was involved in the selection process for the Rick Vecellio Memorial Conservation Scholarship and was honored to present the recipient with the award during the North Bend ceremony.



During the state's 49th annual Youth Environmental Day, George Vickers, Environmental Specialist at Toyota's West Virginia Plant, handed out awards to children for their participation in community environmental projects.

- The Keep Jackson Beautiful Commission presented Bodine Aluminum in Jackson, Tennessee, with the **Environmental Stewardship Award for Industry** during the 2012 Mayor's Civic Pride celebration. The Mayor's Civic Pride Awards were established in 1990 as an effort to congratulate and publicly acknowledge businesses and individuals making a positive contribution to the environment. Bodine was recognized for picking up debris in the Cypress Grove Park after the 100-year flood and assisting in the cleanup and creation of the children's section of Liberty Garden's Memorial Park. Bodine was also the first industry in Madison County to participate in the Adopt-A-Highway Program. The first cleanup in April 2012 resulted in the collection of over 800 pounds of debris. The Environmental Stewardship Award follows the recognition in 2011 by the City of Jackson and the Jackson Recreation and Parks Department for the example Bodine sets as a corporate citizen within the Jackson-Madison County community.



The Keep Jackson Beautiful Commission presented Bodine Aluminum in Jackson, Tennessee, with the **Environmental Stewardship Award for Industry** during the 2012 Mayor's Civic Pride celebration. Bodine was recognized for picking up debris in Cypress Grove Park and for assisting in the cleanup and creation of the children's section of Liberty Garden's Memorial Park.

- In April 2012, 75 second-grade students from Northern Elementary, a local Scott County school, visited the Environmental Education Center | Nature Trail at Toyota's Kentucky plant for a special Environmental Field Day. Students from the school participated in activities led by guest organizations, including Louisville Zoo, Kentucky Fish & Wildlife, and the University of Kentucky Cooperative Extension, among others. Also in attendance was "Trip-R," Toyota's environmental mascot who helped students with waste segregation at lunchtime. Trip-R, short for Triple-R (Reduce, Reuse, Recycle), visited the students at the school earlier in the week to teach about recycling. All students were provided with T-shirts, recycled notebooks and reusable water bottles, which each student packed for their field trip to the plant, reducing the need for disposable drink containers. Team members from the plant's Community Relations and Environmental departments were on hand to support the event.



Second-grade students from Northern Elementary visited the Environmental Education Center | Nature Trail at our Georgetown, Kentucky, plant for a special Environmental Field Day. Students participated in activities led by team members from our plant as well as guest organizations, including Louisville Zoo, Kentucky Fish & Wildlife, and the University of Kentucky Cooperative Extension.

RELATED TOPICS

- For more information about the Environmental Education Center | Nature Trail at our Kentucky plant, please see [**Eco-Efficient Operations/Biodiversity**](#).
- For information on our own recycling and waste minimization efforts, please see [**Eco-Efficient Operations/Waste Minimization**](#).
- For more information about how we manage water use in our operations, please see [**Eco-Efficient Operations/Water**](#).

SPOTLIGHT: EMPLOYEES FROM TOYOTA'S CAMBRIDGE PLANT GIVE BACK

Toyota's Cambridge plant celebrated its 25th year in 2011. Approximately 6,500 team members assemble the Toyota Corolla, Toyota Matrix and the Lexus RX 350. Team members at Toyota's manufacturing plant in Cambridge, Ontario, volunteer their time and expertise to help their community in a number of ways:

- A small patch of green at the Cambridge plant is known as the Giving Garden. The garden began in 2009 under the direction of Japanese master gardener Kaz Matsubayashi. With his guidance, and using traditional Japanese techniques, a handful of team members from the plant coaxed vegetables to grow. In 2011, 80 team members worked in the garden and produced 360 kilograms (740 pounds) of vegetables including potatoes, beets, lettuce, cucumbers, tomatoes, radishes and onions. The harvest went to St. John's Kitchen to be used in meals served at the downtown Kitchener Homeless Shelter, and to women's shelters in Kitchener and Cambridge. The shelters also provide instructional cooking, canning and freezing sessions based on the vegetables donated.



Team members at our plant in Cambridge, Ontario, tend the Giving Garden. Last year, the harvest—360 kilograms (740 pounds) of produce—was donated to St. John's Kitchen to be used in meals served at the downtown Kitchener Homeless Shelter and at the women's shelters in Kitchener and Cambridge.

- In May 2011, our plants experienced a production slow-down as a result of the 2011 Tohoku earthquake and tsunami disasters in Japan and the resulting parts shortage. We took this opportunity to launch the Community Support Program. Over 1,000 team members volunteered to support the community by painting, tree planting and cleaning. Groups of team members enthusiastically tackled projects like planting over 3,000 trees for the Grand River Conservation Authority in Cambridge. A group also went to Shade's Mills Conservation Area in Cambridge for a day to paint the exterior of the Toyota Nature Center, along with other structures by the Ball Diamond, the beach and shelters along the trails.
- Our Cambridge volunteers contributed to beautification of their community during their fifth Adopt-A-Road event. The plant adopted the three-kilometer stretch of Fountain Street in front of the plant in 2009. Volunteers have been conducting bi-annual cleanup events ever since. The crew has more than doubled since the first event. This has allowed the ambitious group to expand their efforts to a wider area surrounding the Cambridge facilities to "sweep-it-clean."



Our plant in Cambridge, Ontario, adopted the three-kilometer stretch of Fountain Street in front of the plant in 2009. Team members have been conducting bi-annual cleanup events ever since. The crew for the fifth Adopt-A-Road event, shown here, has more than doubled since the first event.

- Coffee cups in the Cambridge plant cafeteria are made of compostable material; however, the lids for these cups are not. This means the lids should not be placed in the compost receptacle with the coffee cups; instead, they should be placed in a separate recycling bin. The plant decided to offer to make quarterly donations to registered children's charities to reward team members for spending the extra time to separate the cup and the lid and place them into the correct receptacles. This program has had great success. Organizations receiving the quarterly "Lids for Kids" donations of \$2,500 have included Camp Discovery (for children with diabetes), the Cambridge Self Help Food Bank for their "Penny Harvest" program, and Strong Start, an organization in Waterloo Region that helps young children learn to read.



Coffee cups in the Cambridge plant cafeteria are made of compostable material; however, the lids for these cups are not. The plant decided to offer to make quarterly "Lids for Kids" donations to registered children's charities to reward team members for spending the extra time to separate the cup and the lid and place them into the correct receptacles.

This is just a sampling of the activities that team members at our Cambridge plant engage in every year. Thanks to their volunteer work and their commitment to *kaizen*, or continuous improvement, Toyota Motor Manufacturing Canada was selected as one of **Canada's Greenest Employers 2012** by the editors of the "Canada's Top 100 Employers" project. This special designation recognizes employers that are leaders in creating a culture of environmental awareness in their organizations.

"The wide diversity of activities exemplifies the major contributions our team members make to the community by sharing their knowledge and enthusiasm," said Fred Volf, Vice President of Manufacturing and Environmental Director at Toyota Motor Manufacturing Canada. "This engagement fosters environmental awareness not just here, but also in the local community." Last year, more than 180 charitable groups and organizations received financial and volunteer support from our Cambridge plant. The support we show for our community gives voice to who we are as a global enterprise, the values we embody, and the good that we are striving to accomplish.