

# 12EQ Tandem Axle Equipment

<b>G.V.W.R.</b>	12,000#	<b>AXLES</b>	Two 6,000# EZ Lube w/Electric Brakes
<b>G.A.W.R. (Ea. Axle)</b>	6,000#	<b>SUSPENSION</b>	Multi-Leaf Spring w/Equalizer
<b>COUPLER</b>	Adjustable Forged 2-5/16"	<b>TIRE</b>	ST235/80R16 Load Range E
<b>SAFETY CHAINS</b>	1/4" Grd. 70 w/Safety Latch Hook (2 each)	<b>WHEEL</b>	16 x 6 Radial White Spoke 8 Bolt
<b>JACK</b>	7K Top Wind Drop Leg (Bolted On)	<b>FLOOR</b>	2" Pine
<b>TONGUE</b>	Integral w/Frame	<b>LIGHTS</b>	D.O.T. Stop, Tail, Turn & Clearance
<b>TOP RAIL</b>	None	<b>ELEC. PLUG</b>	7-Way RV
<b>FRAME</b>	8" Channel	<b>FINISH (Prep)</b>	Steel is Cleaned to Ensure a Professional Smooth Finish.
<b>CROSSMEMBERS</b>	3" Channel	<b>FINISH</b>	Superior Quality Finish is Applied with Pin-Stripping for a Highly Decorative and Protective Finish.
<b>UPRIGHTS</b>	None		
<b>FENDERS</b>	9" x 72" Double Square Broke, Diamond Plate w/Back (Removable)		

## Standard Features

- Adjustable Forged Coupler
- Safety Chains Attached w/Cold Rolled Eyelets
- 7K Drop Leg Jack
- Expanded Metal in Bottom of Tongue
- Reflective Marker Tape
- Four D-Rings - 2 Per Side
- Floor Secured w/Torx Screws
- Two 6,000# Cambered EZ Lube Axles w/Electric Brakes
- Complete Break-A-Way System w/Charger
- Spare Tire Mount Curbside
- 79" Usable Inside Width
- 32" Dovetail
- 5' Stand-Up Ramps w/Support Leg
- Grommet Mount Sealed Lighting

Dimensions			
Length	A	B	C
14'	165"	103"	62"
16'	190"	115"	75"
18'	215"	127"	88"

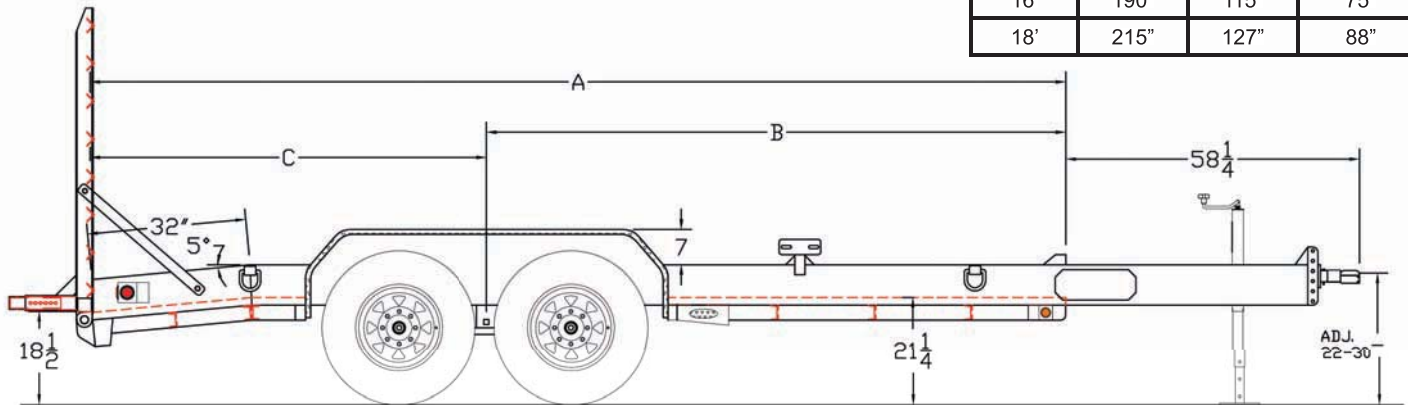

MODEL#	WEIGHT	DESCRIPTION
12EQ-14	2,580#	83" x 14' Tandem Axle Equipment Trailer
12EQ-16	2,830#	83" x 16' Tandem Axle Equipment Trailer
12EQ-18	2,890#	83" x 18' Tandem Axle Equipment Trailer

### OPTIONS

Adjustable Pintle in Channel	Spare Tire (ST235/80 R16 LR-E)
12K Drop Leg Jack	Extra 5/8" D-Rings (each)
Hydraulic Brakes 2 Axles	