

12LX Tandem Axle Low Profile Extra Wide Dump

G.V.W.R.	12,000#	AXLES	Two 6,000# EZ Lube w/Elec. Brakes
G.A.W.R. (Ea. Axle)	6,000#	SUSPENSION	Multi-Leaf Slipper Spring w/Equalizer
COUPLER	2-5/16" Adjustable Forged	TIRE	ST235/80 D-16 Load Range E
SAFETY CHAINS	1/4" Grd. 70 w/Safety Latch Hook (2 each)	WHEEL	16 x 6 White Spoke 8 Bolt
JACKS	7K TW Drop Leg (Bolted On)	FLOOR	10 Gauge Smooth Steel
TONGUE	6" Channel	LIGHTS	D.O.T. Stop, Tail, Turn & Clearance
FRAME	6" Channel	ELEC. PLUG	7-Way RV
CROSSMEMBERS	4" 13# I-Beam	FINISH (Prep)	Steel is Cleaned to Ensure a Professional Smooth Finish.
BED CROSSMEMBERS	2" x 2" Square Tubing	FINISH	Superior Quality Finish is Applied with Pin-Stripping for a Highly Decorative and Protective Finish.
BED LONG SILS	4" Channel		
BED SIDE RAILS	6-1/2" Formed Angle		
FENDERS	Double Square Broke Diamond Plate		

Standard Features

- Safety Chains Attached w/Cold Rolled Eyelets
- Enclosed Pump & Battery Box Mounted in Front of Bed
- Lockable Control Unit
- 24", 12 Ga. Sides w/Formed Channel Supports
- Modular Sealed Wiring Harness
- 10 Ga. Floor
- 1/2" Tie Rail on all 4 Sides
- Stake Pockets (Sides & Front)
- Tarp Brackets
- 4-5/8" D-Rings Inside Bed
- Self Contained Electric/Hydraulic Scissor Lift
- 45 Degree Dump Angle
- Cambered EZ Lube Axles
- Complete Break-A-Way System w/Charge Line
- Grommet Mount Sealed Lighting
- Double Rear Gates w/Cam Latch

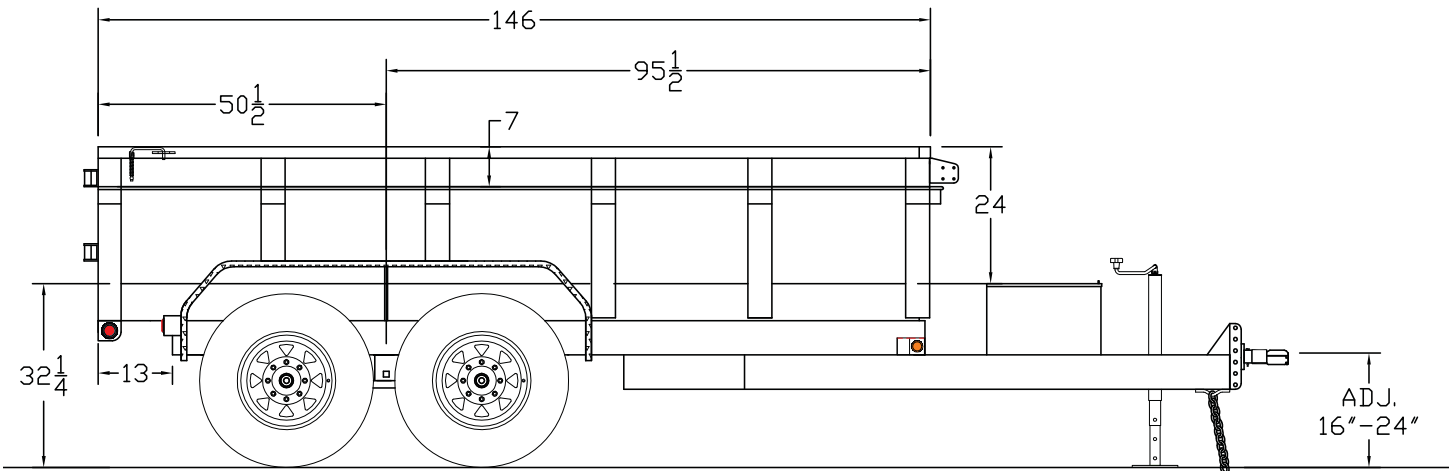

MODEL#	DESCRIPTION
12LX-12	83" x 12' Low Profile Tandem Axle Dump

TRAILER WEIGHTS & CAPACITIES

LENGTH	EMPTY WEIGHT	PAYLOAD	BOX CAPACITY
12'	3,680#	8,320#	6.2 Cubic Yards

OPTIONS

Adjustable Pintle in Channel	Combo Gate
Hydraulic Surge Brakes on Both Axles	Wireless Remote
12K Heavy Duty Top Wind Drop Leg Jack	2 Watt Solar Charger
Spare Tire (ST235/80 D-16 LR-E)	5 Watt Solar Charger
Spare Tire Mount	110V Charger
24" Expanded Metal Side Extensions - 12'	Crank Style Roll Tarp
7' Slide In Ramps	