

S P E C I F I C A T I O N P R O P O S A L

Description	Weight Front	Weight Rear
➤ Vehicle Configuration		
➤ 4700 SET-BACK FRONT AXLE CHASSIS	9,215	6,630
➤ 2018 MODEL YEAR SPECIFIED		
➤ SET BACK AXLE - TRUCK		
➤ TRAILER TOWING PROVISION AT END OF FRAME FOR TRUCK	10	10
➤ LH PRIMARY STEERING LOCATION		
➤ General Service		
➤ TRUCK/TRAILER CONFIGURATION		
➤ DOMICILED, CANADA (OTHER THAN QUEBEC)		
➤ CONSTRUCTION SERVICE		
➤ DRY BULK COMMODITY		
➤ TERRAIN/DUTY: 100% (ALL) OF THE TIME, IN TRANSIT, IS SPENT ON PAVED ROADS		
➤ MAXIMUM 8% EXPECTED GRADE		
➤ SMOOTH CONCRETE OR ASPHALT PAVEMENT - MOST SEVERE IN-TRANSIT (BETWEEN SITES) ROAD SURFACE		
➤ WESTERN STAR VOCATIONAL WARRANTY		
➤ EXPECTED FRONT AXLE(S) LOAD : 20000.0 lbs		
➤ EXPECTED REAR DRIVE AXLE(S) LOAD : 40000.0 lbs		
➤ EXPECTED PUSHER AXLE(S) LOAD : 20000.0 lbs		
➤ EXPECTED GROSS VEHICLE WEIGHT CAPACITY : 80000.0 lbs		
➤ Truck Service		
➤ END DUMP BODY		
➤ Engine		
➤ DETROIT DD13 12.8L 470 HP @ 1625 RPM, 1900 GOV RPM, 1650 LB/FT @ 975 RPM		
➤ Electronic Parameters		
➤ 65 MPH ROAD SPEED LIMIT		
➤ ENABLE DPF REGEN ZONE 1 WITH AUTO ENGINE RPM ELEVATE FOR EXTENDED IDLE		
➤ Engine Equipment		
➤ 2016 ONBOARD DIAGNOSTICS/2010 EPA/CARB/FINAL GHG17 CONFIGURATION		
➤ 2008 CARB EMISSION CERTIFICATION - CLEAN IDLE (INCLUDES 6X4 INCH LABEL ON LOWER FORWARD CORNER OF DRIVER DOOR)		
➤ ENGINE MOUNTED OIL CHECK AND FILL		

Paver Chassis



Description	Weight Front	Weight Rear
➤ ONE PIECE VALVE COVER		
➤ SIDE OF HOOD AIR INTAKE WITH DONALDSON HIGH CAPACITY AIR CLEANER WITH SAFETY ELEMENT, FIREWALL MOUNTED		
➤ DR 12V 160 AMP 28-SI QUADRAMOUNT PAD ALTERNATOR WITH REMOTE BATTERY VOLT SENSE		
➤ (3) ALLIANCE MODEL 1231, GROUP 31, 12 VOLT MAINTENANCE FREE 3375 CCA THREADED STUD BATTERIES	-10	
➤ BATTERY BOX FRAME MOUNTED	35	
➤ SINGLE BATTERY BOX FRAME MOUNTED LH SIDE UNDER CAB		
➤ WIRE GROUND RETURN FOR BATTERY CABLES WITH ADDITIONAL FRAME GROUND RETURN		
➤ NON-POLISHED BATTERY BOX COVER		
➤ BW MODEL BA-921 19.0 CFM SINGLE CYLINDER AIR COMPRESSOR WITH SAFETY VALVE		
➤ AIR COMPRESSOR DISCHARGE LINE		
➤ ELECTRONIC ENGINE INTEGRAL SHUTDOWN PROTECTION SYSTEM		
➤ JACOBS COMPRESSION BRAKE		
➤ RH OUTBOARD UNDER STEP MOUNTED HORIZONTAL AFTERTREATMENT SYSTEM ASSEMBLY WITH RH B-PILLAR MOUNTED VERTICAL TAILPIPE		
➤ ENGINE AFTERTREATMENT DEVICE, AUTOMATIC OVER THE ROAD REGENERATION AND DASH MOUNTED REGENERATION REQUEST SWITCH		
➤ 11 FOOT 06 INCH (138 INCH+0/-5.9 INCH) EXHAUST SYSTEM HEIGHT		
➤ STANDARD CURVE BRIGHT UPPER STACK(S)		
➤ RH CURVED VERTICAL TAILPIPE B-PILLAR MOUNTED ROUTED FROM STEP		
➤ 6 GALLON DIESEL EXHAUST FLUID TANK		
➤ STANDARD DIESEL EXHAUST FLUID PUMP MOUNTING		
➤ LH MEDIUM DUTY STANDARD DIESEL EXHAUST FLUID TANK LOCATION		
➤ STAINLESS STEEL AFTERTREATMENT DEVICE/MUFFLER/TAILPIPE SHIELD		
➤ BORG WARNER (KYSOR) REAR AIR ON/OFF ENGINE FAN CLUTCH		
➤ AUTOMATIC FAN CONTROL WITHOUT DASH SWITCH, NON ENGINE MOUNTED		
➤ DDC SUPPLIED ENGINE MOUNTED FUEL FILTER/FUEL WATER SEPARATOR WITH WATER-IN-FUEL INDICATOR		
➤ FULL FLOW OIL FILTER		
➤ 1500 SQUARE INCH ALUMINUM RADIATOR		
➤ ANTIFREEZE TO -34F, OAT (NITRITE AND SILICATE FREE) EXTENDED LIFE COOLANT		

Paver Chassis



Description	Weight Front	Weight Rear
➤ GATES BLUE STRIPE COOLANT HOSES OR EQUIVALENT		
➤ CONSTANT TENSION HOSE CLAMPS FOR COOLANT HOSES		
➤ HDEP FIXED RATIO COOLANT PUMP AND RADIATOR DRAIN VALVE		
➤ NO RADIATOR/OIL PAN GUARD	-5	
➤ PHILLIPS-TEMRO 1500 WATT/115 VOLT BLOCK HEATER		
➤ CHROME ENGINE HEATER RECEPTACLE MOUNTED UNDER LH DOOR		
➤ ALUMINUM FLYWHEEL HOUSING		
➤ DELCO 12V MOD 3.175-39MT+ OCP STARTER WITH THERMAL PROTECTION AND INTEGRATED MAGNETIC SWITCH		
➤ Transmission		
➤ ALLISON 4000 RDS AUTOMATIC TRANSMISSION WITH PTO PROVISION	170	50
➤ Transmission Equipment		
➤ PTO MOUNTING, LH SIDE OF MAIN TRANSMISSION		
➤ MAGNETIC PLUGS, ENGINE DRAIN, TRANSMISSION DRAIN, AXLE(S) FILL AND DRAIN		
➤ PUSH BUTTON ELECTRONIC SHIFT CONTROL, DASH MOUNTED		
➤ WATER TO OIL TRANSMISSION COOLER, FRAME MOUNTED	15	
➤ TRANSMISSION OIL CHECK AND FILL WITH ELECTRONIC OIL LEVEL CHECK		
➤ SYNTHETIC TRANSMISSION FLUID (TES-295 COMPLIANT)		
➤ Front Axle and Equipment		
➤ MFS-20-133A 20,000# FL1 71.0 INCH KPI/3.74 INCH DROP SINGLE FRONT AXLE	60	
➤ MERITOR 16.5X6 Q+ CAST SPIDER CAM FRONT BRAKES, DOUBLE ANCHOR, FABRICATED SHOES		
➤ NON-ASBESTOS FRONT BRAKE LINING		
➤ CONMET CAST IRON FRONT BRAKE DRUMS		
➤ FRONT BRAKE DUST SHIELDS	5	
➤ MERITOR AUTOMATIC FRONT SLACK ADJUSTERS		
➤ TRW THP-60 POWER STEERING WITH RCH45 AUXILIARY GEAR	90	
➤ 4 QUART POWER STEERING RESERVOIR		
➤ OIL/AIR POWER STEERING COOLER		
➤ SYNTHETIC 50W FRONT AXLE LUBE		
➤ Front Suspension		
➤ 20,000# FLAT LEAF FRONT SUSPENSION	50	
➤ GRAPHITE BRONZE BUSHINGS WITH SEALS - FRONT SUSPENSION		

Paver Chassis



Description	Weight Front	Weight Rear
➤ Rear Axle and Equipment		
➤ RT-46-164 46,000# R-SERIES TANDEM REAR AXLE		500
➤ 4.89 REAR AXLE RATIO		
➤ MXL 18T MERITOR EXTENDED LUBE MAIN DRIVELINE WITH HALF ROUND YOKES	80	80
➤ MXL 17T MERITOR EXTENDED LUBE INTERAXLE DRIVELINE WITH HALF ROUND YOKES		
➤ DRIVER CONTROLLED TRACTION DIFFERENTIAL - BOTH TANDEM REAR AXLES		30
➤ (1) INTERAXLE LOCK VALVE, (1) DRIVER CONTROLLED DIFFERENTIAL LOCK FORWARD-REAR AND REAR-REAR AXLE VALVE		
➤ INDICATOR LIGHT FOR EACH INTERAXLE LOCKOUT SWITCH		
➤ INDICATOR LIGHT FOR EACH DRIVER CONTROLLED TRACTION DEVICE SWITCH		
➤ MERITOR 16.5X8.62 Q+ CAST SPIDER CAM REAR BRAKES, DOUBLE ANCHOR, FABRICATED SHOES		
➤ NON-ASBESTOS REAR BRAKE LINING		
➤ BRAKE CAMS AND CHAMBERS ON FORWARD SIDE OF DRIVE AXLE(S) WITH AUXILIARY SUPPORT BRACKETS		
➤ CONMET CAST IRON REAR BRAKE DRUMS		
➤ REAR BRAKE DUST SHIELDS		10
➤ SKF SCOTSEAL PLUS XL REAR OIL SEALS		
➤ HALDEX GOLDSEAL LONGSTROKE 2-DRIVE AXLES SPRING PARKING CHAMBERS		
➤ MERITOR AUTOMATIC REAR SLACK ADJUSTERS		
➤ SYNTHETIC 75W-90 REAR AXLE LUBE		
➤ Rear Suspension		
➤ AIRLINER 46,000# REAR SUSPENSION		390
➤ AIRLINER HIGH POSITION RIDE HEIGHT		
➤ RESTRAINED AXLE SEATS IN AXLE CLAMP GROUP		
➤ 51 INCH AXLE SPACING		
➤ MANUAL DUMP VALVE FOR AIR SUSPENSION WITHOUT GAUGE		
➤ INDICATOR LIGHT FOR EACH REAR SUSPENSION CONTROL SWITCH		
➤ SINGLE AIR REAR SUSPENSION LEVELING VALVE		
➤ TRANSVERSE CONTROL RODS		
➤ REAR SHOCK ABSORBERS - TWO AXLES (TANDEM) (AIR RIDE SUSPENSION)		
➤ Pusher / Tag Equipment		



Description	Weight Front	Weight Rear
➤ HENDRICKSON SC20 COMPOSILITE 20,000# AIR LIFT STEERABLE PUSHER SUSPENSION, 16.5X6 BRAKES AND FL1 AXLE	925	930
➤ HENDRICKSON SC20/SCO20 20,000# FL1 STEERABLE 16.5X6 BRAKE INTEGRAL PUSHER AXLE		
➤ (1) DASH VALVE AND (1) GAUGE FOR SINGLE LIFT AXLE		
➤ REVERSE LIFT AXLE WIRING WITH LAST STATE RETENTION WITH IGNITION OFF		
➤ AIR PIPING FOR (1) LIFT/NON-LIFT AXLE WITH REGULATOR CHASSIS MOUNTED		
➤ HENDRICKSON 16.5X6 CAST SPIDER CAM PUSHER/TAG BRAKES, DOUBLE ANCHOR, FABRICATED SHOES		
➤ NON-ASBESTOS PUSHER/TAG BRAKE LINING		
➤ CONMET CAST IRON PUSHER/TAG BRAKE DRUMS		
➤ PUSHER/TAG BRAKE DUST SHIELDS		
➤ SKF SCOTSEAL PLUS XL PUSHER/TAG OIL SEALS		
➤ VENTED PUSHER/TAG HUB CAPS WITH WINDOW, CENTER AND SIDE PLUGS - OIL		
➤ HALDEX LONGSTROKE PUSHER/TAG AXLE SERVICE CHAMBERS		
➤ HALDEX AUTOMATIC PUSHER/TAG SLACK ADJUSTERS		
➤ HENDRICKSON SC20 COMPOSILITE 20,000# STEERABLE AIR LIFT PUSHER SUSPENSION		
➤ 100 INCH AXLE SPACING PUSHER/TAG		
➤ Brake System		
➤ WABCO 4S/4M ABS WITHOUT TRACTION CONTROL		
➤ BW AD-9 BRAKE LINE AIR DRYER WITH HEATER	20	
➤ BENDIX OIL COALESCING FILTER FOR AIR DRYER		
➤ AIR DRYER FRAME MOUNTED		
➤ STEEL AIR BRAKE RESERVOIRS		
➤ PULL CABLES ON ALL AIR RESERVOIR(S)		
➤ Trailer Connections		
➤ AIR CONNECTIONS TO END OF FRAME WITH GLAD HANDS FOR TRUCK AND NO DUST COVERS		
➤ PRIMARY CONNECTOR/RECEPTACLE WIRED FOR SEPARATE STOP/TURN, ABS CENTER PIN POWERED THROUGH IGNITION		
➤ SAE J560 7-WAY PRIMARY TRAILER CABLE RECEPTACLE MOUNTED END OF FRAME		
➤ Wheelbase & Frame		
➤ 6500MM (256 INCH) WHEELBASE		
➤ 11/32X3-1/2X10-15/16 INCH STEEL FRAME (8.73MMX277.8MM/0.344X10.94 INCH) 120KSI	670	-210

Paver Chassis



	Description	Weight Front	Weight Rear
➤	1/4 INCH (6.35MM) C-CHANNEL INNER FRAME REINFORCEMENT	245	426
➤	1575MM (62 INCH) REAR FRAME OVERHANG		
➤	CALC'D BACK OF CAB TO REAR SUSP C/L (CA) : 192.69 in		
➤	CALCULATED EFFECTIVE BACK OF CAB TO REAR SUSPENSION C/L (CA) : 189.69 in		
➤	SQUARE END OF FRAME		
➤	HEAVY DUTY SUSPENSION CROSSMEMBER		
➤ Chassis Equipment			
➤	14 INCH CHROMED STEEL BUMPER		
➤	REMOVABLE FRONT TOW HOOKS STORED ON THE CHASSIS FRAME	25	
➤	BUMPER MOUNTING FOR SINGLE LICENSE PLATE		
➤	FRONT ANTI-SPRAY CAB MOUNTED MUDFLAPS		
➤	GRADE 8 THREADED HEX HEADED FRAME FASTENERS		
➤ Fuel Tanks			
➤	80 GALLON/302 LITER ALUMINUM FUEL TANK - LH	10	
➤	25 INCH DIAMETER FUEL TANK(S)		
➤	PLAIN ALUMINUM FUEL TANK(S) WITH POLISHED STAINLESS STEEL BANDS		
➤	FUEL TANK(S) AFT	-35	35
➤ Tires			
➤	MICHELIN XFE 425/65R22.5 20 PLY RADIAL FRONT TIRES	172	
➤	CONTINENTAL HDC1 11R22.5 16 PLY RADIAL REAR TIRES		136
➤	MICHELIN XFE 425/65R22.5 20 PLY RADIAL PUSHER TIRES		196
➤ Hubs			
➤	CONMET PRESET PLUS IRON FRONT HUBS		
➤	CONMET PRESET PLUS IRON REAR HUBS		
➤	CONMET PRESET PLUS IRON PUSHER/TAG HUBS		
➤ Wheels			
➤	ALCOA LVL ONE 82462X 22.5X12.25 10-HUB PILOT 4.68 INSET 10-HAND ALUMINUM DISC FRONT WHEELS	-8	
➤	ALCOA LVL ONE 88367X 22.5X8.25 10-HUB PILOT ALUMINUM DISC REAR WHEELS		-200
➤	ALCOA LVL ONE 82462X 22.5X12.25 10-HUB PILOT 4.68 INSET 10-HAND ALUMINUM DISC PUSHER/TAG WHEELS		-8
➤	POLISHED FRONT WHEELS; OUTSIDE ONLY		
➤	POLISHED REAR WHEELS; OUTSIDE OF OUTER WHEELS ONLY		
➤	POLISHED PUSHER/TAG WHEELS; OUTSIDE OF OUTER WHEEL ONLY		
➤ Cab Exterior			

Paver Chassis



Description	Weight Front	Weight Rear
➤ 110 INCH BBC STEEL CONVENTIONAL CAB		
➤ WESTERN STAR PAINTED ALUMINUM CAB SKIRT		
➤ AIR CAB MOUNTS WITH CHECK VALVE		
➤ NONREMOVABLE BUGSCREEN MOUNTED BEHIND GRILLE		
➤ 2 INCH FENDER EXTENSIONS	5	
➤ LH AND RH EXTERIOR GRAB HANDLES WITH RUBBER INSERTS AND RH INTERIOR GRAB HANDLE MOUNTED TO A POST		
➤ STATIONARY BRIGHT FINISH GRILLE		
➤ CHROME HOOD MOUNTED AIR INTAKE GRILLE		
➤ HEAVY DUTY STEEL CAB FLOOR		
➤ FIBERGLASS HOOD		
➤ DUAL ROUND AIR HORNS, SINGLE BASE, MOUNTED UNDER CAB		
➤ SINGLE ELECTRIC HORN		
➤ DOORS AND IGNITION KEYED THE SAME		
➤ REAR LICENSE PLATE MOUNT END OF FRAME		
➤ SINGLE RECTANGULAR SEALED BEAM HEADLIGHTS WITH BRIGHT BEZELS		
➤ LED MARKER LAMPS		
➤ DAYTIME RUNNING LIGHTS		
➤ INDIVIDUAL LED STOP/TURN/BACKUP LIGHTS GROMMET MOUNTED OUTBOARD OF RAIL		5
➤ STANDARD FRONT TURN SIGNAL LAMPS		
➤ DUAL STAINLESS STEEL HEATED MIRRORS		
➤ DOOR MOUNTED MIRRORS		
➤ 102 INCH EQUIPMENT WIDTH		
➤ LH AND RH 8 INCH STAINLESS STEEL CONVEX MIRRORS MOUNTED BELOW PRIMARY MIRRORS		
➤ RH DOWN VIEW MIRROR		
➤ FIBERGLASS EXTERIOR SUN VISOR	24	
➤ 17.5X35 INCH TINTED REAR WINDOW		
➤ TINTED DOOR GLASS		
➤ RH AND LH ELECTRIC POWERED WINDOWS	4	
➤ 2-PIECE TINTED CURVED BONDED WINDSHIELD		
➤ 2 GALLON WINDSHIELD WASHER RESERVOIR WITHOUT FLUID LEVEL INDICATOR, MOUNTED UNDER CAB, WITH REMOTE FILL		

➤ **Cab Interior**

- GRAY VINYL BASE INTERIOR
- BLACK HARD TRIM
- BASE LEFT HAND DOOR TRIM
- BASE RIGHT HAND DOOR TRIM

Paver Chassis



Description	Weight Front	Weight Rear
➤ BLACK MATS WITH SINGLE INSULATION		
➤ DASH MOUNTED ASH TRAY AND LIGHTER, DRIVER SIDE		
➤ FORWARD ROOF MOUNTED CONSOLE		
➤ PASSENGER SIDE WING DASH MOUNTED GLOVE BOX WITH LOCKING DOOR		
➤ LH AND RH DOOR MAP POCKETS		
➤ COAT HOOK ON RH BACKWALL OF CAB		
➤ (1) CUP HOLDER MOUNTED IN BOTTOM CENTER OF DASH		
➤ TWO-TONE CHARCOAL UPPER/COOL GRAY LOWER SOFT TOUCH WING DASH WITH BLACK DRIVER SIDE COSMETIC UNDER DASH COVER		
➤ STANDARD WIRING		
➤ 2-1/2 LB. FIRE EXTINGUISHER MOUNTED OUTBOARD OF DRIVER SEAT	5	
➤ HEATER, DEFROSTER AND AIR CONDITIONER WITH CONSTANT OUTLET TEMPERATURE CONTROL		
➤ HVAC DUCTING WITH FOAM MAIN FRESH AIR FILTER AND OUTSIDE PRE-FILTER		
➤ MAIN HVAC CONTROLS WITH RECIRCULATION SWITCH		
➤ CAB INSULATION		
➤ AUTOMATIC SELF-RESET CIRCUIT BREAKER IN MAIN DASH POWER DISTRIBUTION BOX AND CIRCUIT BREAKER/FUSE IN AUXILIARY POWER DISTRIBUTION BOXES		
➤ DOOR ACTIVATED DOME LIGHT, UNDER DASH LIGHT WITH LH AND RH DOOR MOUNTED COURTESY LIGHTS AND LH AND RH READING LIGHTS		
➤ CAB DOOR LATCHES WITH MANUAL DOOR LOCKS		
➤ TRIANGULAR REFLECTORS KIT WITHOUT FLARES SHIPPED LOOSE IN CAB	10	
➤ BASIC HIGH BACK AIR SUSPENSION DRIVER SEAT WITH 1 CHAMBER AIR LUMBAR, INTEGRATED CUSHION EXTENSION AND REAR CUSHION TILT		
➤ BASIC HIGH BACK NON SUSPENSION PASSENGER SEAT		
➤ BLACK CORDURA PLUS CLOTH DRIVER SEAT COVER		
➤ BLACK CORDURA PLUS CLOTH PASSENGER SEAT COVER		
➤ 3 POINT DRIVER AND PASSENGER SEAT BELT RETRACTORS		
➤ ADJUSTABLE TILT AND TELESCOPING STEERING COLUMN		
➤ 2-SPOKE 18 INCH (450MM) BLACK STEERING WHEEL(S)		
➤ DRIVER AND PASSENGER INTERIOR SUN VISORS		
➤ Instruments & Controls		
➤ STAR GAUGES WITH BLACK BEZELS		
➤ ROYAL ROSEWOOD MATTE FINISH DRIVER INSTRUMENT PANEL		

Paver Chassis



Description	Weight Front	Weight Rear
➤ ROSEWOOD VINYL MATTE FINISH CENTER INSTRUMENT PANEL INSERT		
➤ LOW AIR PRESSURE INDICATOR LIGHT AND AUDIBLE ALARM		
➤ 2 INCH PRIMARY AND SECONDARY AIR PRESSURE GAUGES		
➤ INTAKE MOUNTED AIR RESTRICTION INDICATOR WITH GRADUATIONS		
➤ 97 DB BACKUP ALARM		3
➤ CRUISE CONTROL SWITCHES IN THE CENTER PANEL		
➤ KEY OPERATED IGNITION SWITCH AND INTEGRAL START POSITION; 4 POSITION OFF/RUN/START/ACCESSORY		
➤ WARNING LAMP/LIGHT BAR DISPLAY, NON-DATA LINKED		
➤ HEAVY DUTY ONBOARD DIAGNOSTICS INTERFACE CONNECTOR LOCATED BELOW LH DASH		
➤ 2 INCH ELECTRIC FUEL GAUGE		
➤ FUEL FILTER RESTRICTION INDICATOR		
➤ EMISSIONS LIMITED IDLE ADJUST		
➤ ELECTRICAL ENGINE COOLANT TEMPERATURE GAUGE		
➤ ENGINE OIL TEMPERATURE GAUGE		
➤ 2 INCH TRANSMISSION OIL TEMPERATURE GAUGE		
➤ ELECTRIC ENGINE OIL PRESSURE GAUGE		
➤ AM/FM/WB RADIO WITH BLUETOOTH AND MICROPHONE, FRONT USB PORT, FRONT AND REAR AUXILIARY INPUTS AND J1939	10	
➤ ROOF/OVERHEAD CONSOLE MOUNTED RADIO		
➤ (4) RADIO SPEAKERS IN CAB		
➤ POWER AND GROUND WIRING FOR CB RADIO IN OVERHEAD CONSOLE		
➤ MULTI-BAND AM/FM/WB/CB LH MIRROR MOUNTED ANTENNA SYSTEM		
➤ ELECTRONIC KPH SPEEDOMETER WITH SECONDARY MPH SCALE, WITH ODOMETER		
➤ ELECTRONIC 3000 RPM TACHOMETER		
➤ DETROIT CONNECT VIRTUAL TECHNICIAN CONNECTIVITY PACKAGE (DETROIT ENGINES ONLY)		
➤ 5 YEARS TOTAL VIRTUAL TECHNICIAN REMOTE DIAGNOSTICS SERVICE (3 YEARS ADDITIONAL TO STANDARD)		
➤ IGNITION SWITCH CONTROLLED ENGINE STOP		
➤ BW TRACTOR PROTECTION VALVE		
➤ TRAILER HAND CONTROL BRAKE VALVE		
➤ 2 INCH VOLTMETER		
➤ SINGLE ELECTRIC WINDSHIELD WIPER MOTOR WITH DELAY		
➤ CAB/TRAILER MARKER LIGHT SWITCH WITH SEPARATE HEADLIGHT SWITCH		

Paver Chassis



	Description	Weight Front	Weight Rear
➤	TWO VALVE PARKING BRAKE SYSTEM WITH WARNING INDICATOR		
➤	VSM NON CANCELING TURN SIGNAL SWITCH WITH INTEGRAL HEADLAMP DIMMER WITHOUT BRAKE OVERRIDE		
➤	PACIFIC INSIGHT ELECTRONIC FLASHER		
➤ Design			
➤	PAINT: ONE SOLID COLOR		
➤ Color			
➤	CAB COLOR A: L0006EB WHITE ELITE BC		
➤	CAB INTERIOR PAINTED SAME AS CAB COLOR		
➤	BLACK, HIGH SOLIDS POLYURETHANE CHASSIS PAINT		
➤	SUNVISOR PAINTED SAME AS CAB COLOR A		

T O T A L V E H I C L E S U M M A R Y

Weight Summary

	Weight Front	Weight Rear	Total Weight
Factory Weight ⁺	11787 lbs	9013 lbs	20800 lbs

(+) Weights shown are estimates only.
 If weight is critical, contact Customer Application Engineering.



D I M E N S I O N S

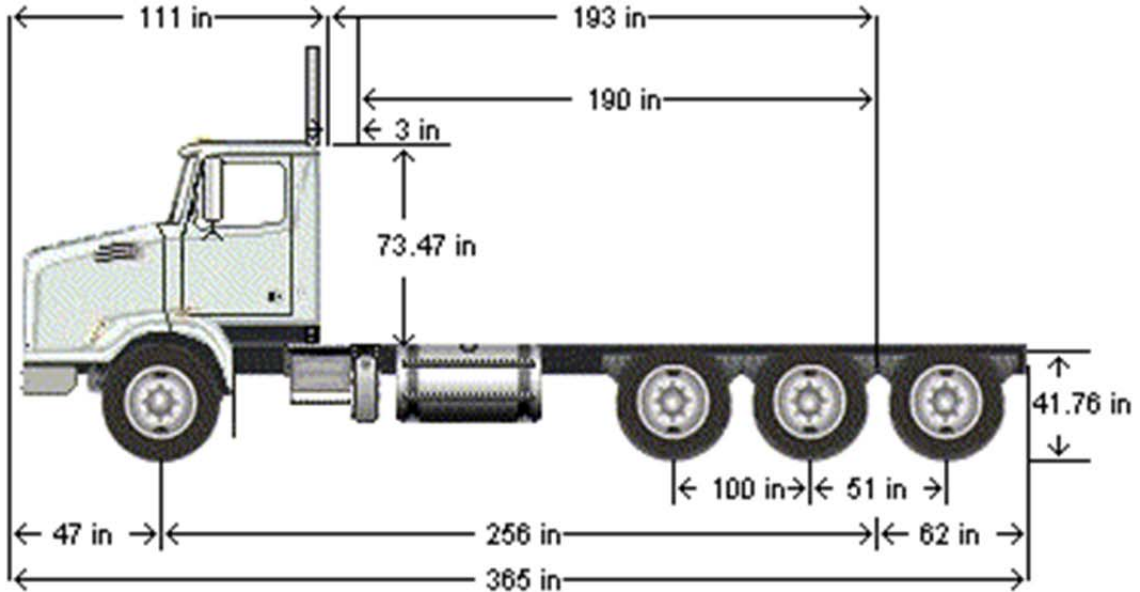

VEHICLE SPECIFICATIONS SUMMARY - DIMENSIONS

Model	4700SB
Wheelbase (545).....	6500MM (256 INCH) WHEELBASE
Rear Frame Overhang (552).....	1575MM (62 INCH) REAR FRAME OVERHANG
Cab Size (829).....	110 INCH BBC STEEL CONVENTIONAL CAB
Exhaust System (016).....	RH OUTBOARD UNDER STEP MOUNTED HORIZONTAL AFTERTREATMENT SYSTEM ASSEMBLY WITH RH B-PILLAR MOUNTED VERTICAL TAILPIPE

Paver Chassis



TABLE SUMMARY - DIMENSIONS

Dimensions	Inches
Bumper to Back of Cab (BBC)	110.7
Bumper to Centerline of Front Axle (BA)	47.4
Min. Cab to Body Clearance (CB)	3.0
Back of Cab to Centerline of Rear Axle(s) (CA)	192.7
Effective Back of Cab to Centerline of Rear Axle(s) (Effective CA)	189.7
Back of Cab Protrusions (Exhaust/Intake) (CP)	1.5
Back of Cab Protrusions (Side Extenders/Trim Tab) (CP)	0.0
Back of Cab Protrusions (CNG Tank)	0.0
Back of Cab Clearance (CL)	3.0
Back of Cab to End of Frame	254.7
Cab Height (CH)	73.5
Wheelbase (WB)	256.0
Frame Overhang (OH)	62.0
Overall Length (OAL)	365.4
Rear Axle Spacing	51.0
Pusher/Tag Axle Spacing	100.0
Unladen Frame Height at Centerline of Rear Axle	41.8

Performance calculations are estimates only. If performance calculations are critical, please contact Customer Application Engineering.