

**1967
FORD**

BRONCO

ALL-PURPOSE 4-WHEEL-DRIVE UTILITY VEHICLES



Put your brand on Bronco for fun or work

Now you have a choice of five Broncos . . . Wagon, Pickup, Roadster, Sport Wagon and Sport Pickup. Whichever Bronco you select, it will do what you want it to do . . . where you want to do it!

These Broncos move through mud, snow, sand . . . on or off the road, in 2- or 4-wheel drive . . . comfortably and in style. But don't let Bronco's styling fool you! Broncos are rugged . . . engineered to do just about anything!

You can carry your tools or camping gear and bulky supplies with you. Hook up a winch, snowplow, rotary brush . . . and get the job done in a hurry.

You don't need a fleet of vehicles either . . . just Bronco. Ford's versatile, sure-footed, 4-wheel-drive Bronco is an ideal work and play vehicle.



SPORT BRONCO WAGON

BRONCO WAGON

If you want a completely enclosed Bronco, the Wagon is for you. Doors and rear liftgate are lockable; door windows crank up and down. The upper body is removable. Standard equipment includes a big 170-cubic-inch six-cylinder engine, fully synchronized 3-speed transmission, 2-speed constant-mesh transfer case, full-width front seat, front and rear shock absorbers, and 15-inch wheels. Choose either the Standard or Sport Wagon.

BRONCO ROADSTER

The Roadster is a sporty all-purpose vehicle, having the same basic equipment as the other models, but without doors and roof. Smoothly contoured door openings give it a sporty appearance. Optional steel doors are available with glass and frames. A vinyl roof and vinyl doors are dealer-installed accessories. The windshield can be folded flat on the hood and locked in place. A full-width front seat is standard. Bronco Roadster makes a great beach buggy!

BRONCO PICKUP

The Pickup model is similar to the Wagon, except that it has a short roof and open cargo box. As with Wagon and Roadster, the tailgate is a full 56 inches wide and has a convenient one-hand-operated latch. The sturdy, lightweight roof is removable. The cargo box has over 32 cubic feet of loadspace. Bronco Pickups are available as Standard or Sport models. Bronco Pickups are excellent service station and off-road construction utility vehicles.



BRONCO ROADSTER

BRONCO PICKUP

Bronco comfort and convenience

Whether you prefer the Wagon, Pickup or Roadster—standard or Sport models—you are assured of maximum comfort and convenience in the 1967 Ford Bronco. Interiors are attractive and functional. Bronco offers plenty of leg room. It seats three comfortably on a full-width front seat . . . or you can choose bucket seats. The transmission shift lever is mounted out of the way on the steering column,

and the transfer case is operated by a single, floor-mounted T-bar shift lever. Brake and clutch pedals are centered about the steering column. The cargo area is over 55 inches long and 56 inches wide, with plenty of room between wheel-housings for an optional two-passenger seat on Roadster and Wagon models.



Front Bench Seat. A three-man, full-width front seat is standard on all Broncos and is upholstered in Parchment-colored vinyl trim. Front seat travel adjustment is five full inches.



Front Bucket Seats. For extra comfort and luxury, attractive bucket seats are available. These bucket seats are upholstered with Parchment-colored, durable Ford vinyl trim.

Sport Broncos . . . Wagon and Pickup

Sport Bronco Wagon and Pickup features in addition to or in place of standard features include: Bright-metal instrument panel molding • Vinyl-covered door trim panels with bright-metal moldings • Hardboard headlining with bright-metal retainer moldings (Wagon models) • Vinyl front floor mat with bright-metal retainers • Bright-metal seat pivot arm covers (w/optional bucket seats) • Arm rests, LH and RH • Cigar-cigarette lighter • Chrome horn ring • Bright-metal drip rail moldings • Bright-metal windshield and window frames • Bright-metal grille molding, headlight and taillight bezels, tailgate release handle • Chrome bumpers, front and rear • Chrome front bumper guards • Bright-metal wheel covers (w/15" wheels only) • "Sport Bronco" emblem.

A wide variety of optional equipment that allows you to customize your Bronco includes: LH & RH arm rests* • Cigar-cigarette lighter* • Cab doors (w/glass and frames—Roadster) • Horn ring* • RH rearview mirror (painted, all models—chrome w/doors) • Manual radio and antenna • Bucket seats • Bench-type rear seat (Roadster and Wagon) • Fresh air heater and defroster • Front and rear chrome bumpers* • Front bumper guards, chrome (w/chrome bumpers only)* • Skid plates (under standard fuel tank and transfer case) • Inside tailgate-mounted spare tire carrier (incl. w/rear seat option) • Bright-metal wheel covers (15-inch wheels only)* • High-flotation tires • Auxiliary 11½-gal. fuel tank with skid plate • Courtesy (map) light • Bright body side and tailgate molding (except Roadster) • Bright-metal rocker panel molding • Extra cooling equipment • Reflectors, front and rear • Dana free-running front hubs • Hand-operated throttle • Dry element air cleaner. *Standard on Sport models

Dealer-Installed Accessories. Convertible top with vinyl doors and plastic windows (Roadster) • Chrome inside handrails • Power take-off • Compass • Warn free-running front hubs • 2-way radio • Snowplow • Front overload air springs • Tachometer • Front-mounted winch • Trailer hitch • Fire extinguisher • Locking gas caps • Tool kit • Front tow hooks (2).



Bucket Seats Plus Rear Bench Seat. You can have Parchment-colored bucket seats installed in front and a matching two-passenger seat in the rear on your Bronco Roadster or Wagon.

Bronco handling is superb on or off the road

The amazing Bronco cruises more smoothly, quietly, comfortably at turnpike speeds . . . handles well on cross-country trips, too! The big 170-cu. in. Six or optional 289-cu. in. V-8 delivers flashing response teamed with the fully synchronized 3-speed transmission and 2-speed through-drive transfer case. Ford's unique Mono-Beam front suspension

and progressive leaf rear springs absorb the bumps, while eight cushioned body mounts soak up road shock and vibration. Exceptional off-road mobility and freedom from getting hung up or damaging undercarriage components are reflected in the design dimensions listed and illustrated below.

Bronco is designed to meet your needs!



Snowplow . . . If you live in snow country, equip your Bronco with a snowplow. Controlled from the cab, the blade may be adjusted to various heights and angles for most effective use.



Camper Body . . . Your Ford Dealer can assist you to acquire a camper body for your Bronco. Bronco's 4-wheel drive is a natural for getting you into the back country.

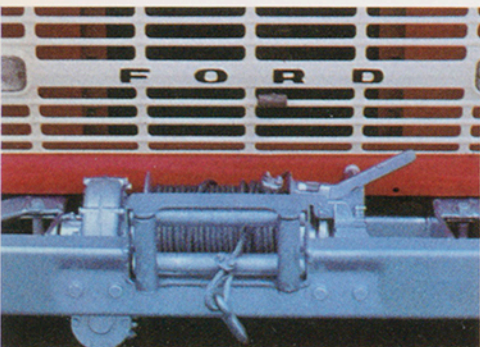

Front-mounted Winch is one example of special equipment that can be run by a power take-off unit. Others include a boom, rotary brush, sickle bar, posthole digger, etc.

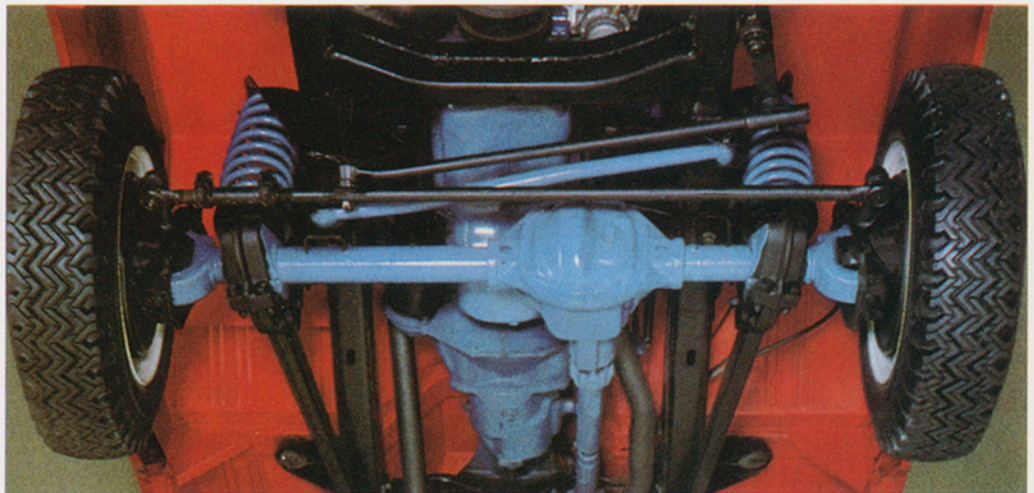

Mono-Beam Suspension . . . Bronco's Mono-Beam front suspension provides the finest riding quality of any vehicle of its type without sacrificing cross-country durability or maneuverability. This is accomplished through the use of rugged, easy-riding coil springs and sturdy forged steel radius rods that are attached to the axle and the frame through heavy rubber shock-absorbing insulators. A forged steel track bar extending across the front provides lateral stability. Bronco's Mono-Beam front suspension is tough and durable . . . designed and built to take on any road, or no road at all!



Stability . . . A wide 57.4-in. track for Bronco's front and rear axles reduces side sway on the highway and provides trail-hugging stability when traversing steep hills.

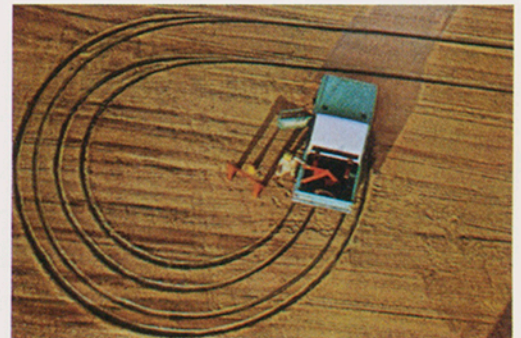

Turning . . . The Bronco turns in a 33.6-ft. diameter . . . less than any other comparable utility vehicle. This ability to turn in a small area comes in mighty handy going round obstacles.

GROUND CLEARANCE ANGLES & DIMENSIONS		
Tires	7.35 x 15	6.50 x 16
Wheelbase (WB)	92"	92"
Angle of Approach (AA)	40.6°	44.1°
Angle of Departure (AD)	27.7°	32.7°
Ramp Breakover Angle (RBA)	29.4°	31.9°
Ground Clearance (GC)		
Front Axle	7.65"	9.45"
Rear Axle	6.6"	8.4"
Sprung	11.6"	13.2"
Turning Diameter (Bumper Clearance)	33.6'	33.6'

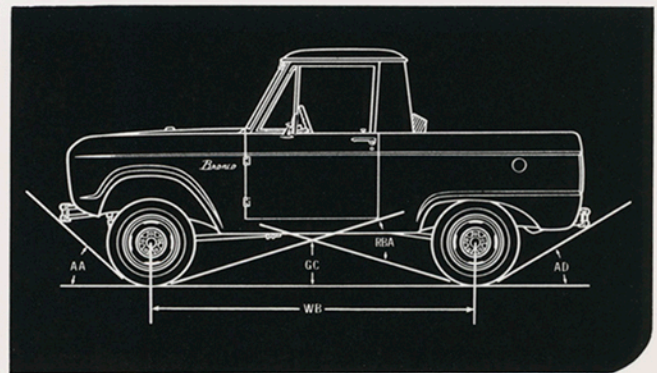

Choice of Rally-Winning Big Six or V-8 Power

The standard engine in all Broncos is the big frisky 170-cu. in., 105-horsepower Six. This engine offers economical power for both highway driving or heavy off-the-road use.

Should you prefer sizzling, total performance on any road with a Ford Bronco, then choose the optional, big 289-cu. in. V-8 that delivers 200 horsepower. Big Six or V-8 . . . Bronco engines are quality-

bred to give you responsive, spirited power at work or play!

Several engine features that make Bronco engines total performers on or off the highway include a specially designed carburetor for steep-grade performance, hydraulic valve lifters (V-8 only), special 6-quart oil pan for hill-country lubrication, no-spill oil-bath air cleaner, Full-Flow oil filter, fully aluminized muffler and tailpipe.

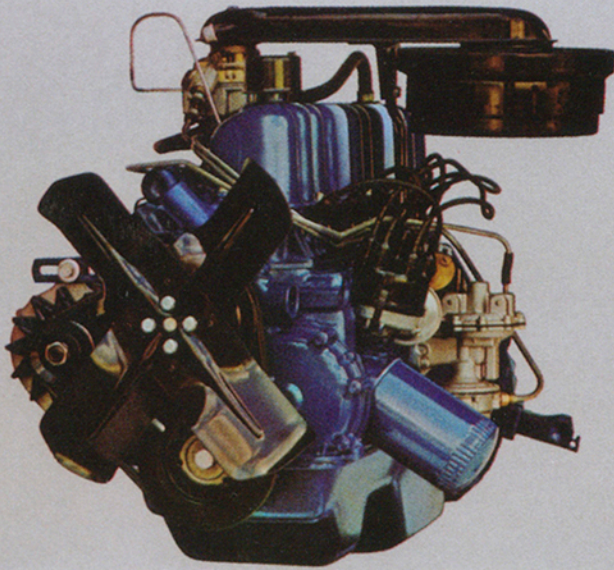

170-cu. in. Six

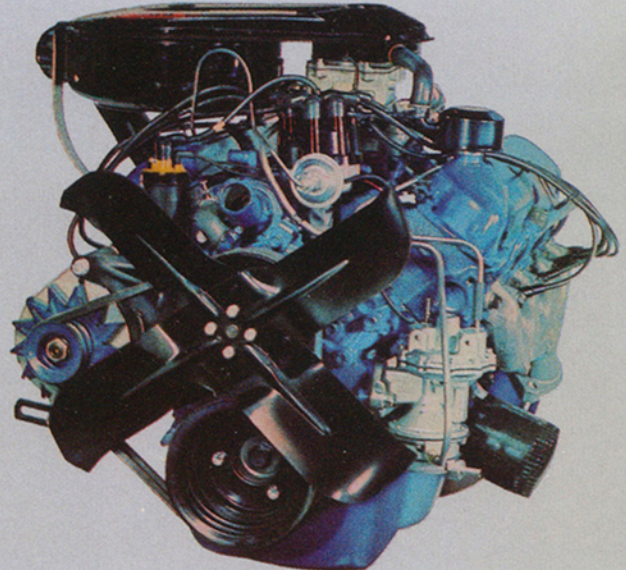

289-cu. in. V-8

6000-MILE MAINTENANCE SCHEDULE

Chassis lubrication, oil and oil filter change, oil-bath air cleaner cleaning and refill are required only every 6,000 miles. Consult your Ford Dealer for additional lubrication/service information.

ENGINE SPECIFICATIONS	170-cu. in. Six (Standard)
Max. Gross HP @ RPM	105 @ 4400
Max. Net HP @ RPM	89 @ 3800
Max. Gross Torque (lbs-ft)	158 @ 2400
Max. Net Torque (lbs-ft)	146 @ 2400
Bore and Stroke (in.)	3.5 x 2.94
Compression Ratio	9.1 to 1

ENGINE SPECIFICATIONS	289-cu. in. V-8 (2V) (Optional)
Max. Gross HP @ RPM	200 @ 4400
Max. Net HP @ RPM	150 @ 4400
Max. Gross Torque (lbs-ft)	282 @ 2400
Max. Net Torque (lbs-ft)	242 @ 2400
Bore and Stroke (in.)	4.00 x 2.87
Compression Ratio	9.3 to 1

EQUIPMENT

STANDARD

OPTIONAL

Alternator:	38 amp., 570 watt	45 amp., 55 amp.
Axle, Front: Capacity (lb.)	2500	Limited-Slip***
Axle, Rear: Capacity (lb.), Ratio (to 1)	2780-4.11	2780-3.50, 4.57; 3300*-3.50, 4.11 or 4.57
Battery: (12 volts)	54 plates, 45 amp-hr.	66 plates, 55 or 70 amp-hr
Brakes, Service: Dual hydraulic system.	Self-adjusting	—
Size (in.) front	11 x 2	—
rear	10 x 2 1/2	—
Brakes, Parking: Type	Cable actuation of rear brakes.	—
Clutch: Dia. (in.)	9 w/Six, 11 w/V-8	HD 9 3/8 w/Six
Engine:	170-cu. in. Six	289-cu. in. V-8
Frame: Section Modulus	2.04	—
Hubs, Front:	—	Free-Running
Shock Absorbers: Front and rear	Double-acting	—
Springs, Front: Coil, Capacity @ pad (lb. ea.)	760 w/Six, 900 w/V-8	850 w/Six, 1000 w/V-8
Springs, Rear: Capacity @ pad (lb. ea.)	Progressive 930	Progressive 1280
Steering: Gemmer	Worm & roller	—
Tank, Fuel:	14.5 gal.	11.5 gal. auxiliary with skid plate
Transfer Case: Constant mesh, Dana 20	2-spd. thru-drive	—
Transmission: Fully synchronized, Ford	3-spd. direct	—
Wheels: No.—type—rim size (in.)	5—5-hole disc—5 1/2 K	5—5-hole disc—5 K
Tires:	Tubeless 7.35 x 15 4PR PT	Tube-type 6.50 x 16 6PR TT**
Color Choices: Raven Black, Wimbledon White, Rangoon Red, Harbor Blue, Springtime Yellow, Pebble Beige, Lunar Green, Holly Green, Peacock Blue, Frost Turquoise, Poppy Red and Chrome Yellow. Bronco metal roofs are painted Wimbledon White to provide a two-tone paint combination.		

*Includes 11" x 1 1/4" rear brakes. **Provides maximum ground clearance and durability. Other tire sizes also available. For high flotation tire sizes see your Ford Dealer. PT—Passenger type. TT—Truck type. ***Requires free-running hubs and limited-slip rear axle.

Note: With standard equipment, Bronco has a GVW rating of 3,900 lb. A special 4700-lb. GVW package may be purchased as a unit. This package includes a Ford 3300-lb. capacity rear axle with 11" x 1 1/4" rear brakes, 1280-lb. rear springs and 8.15 x 15 8PR tubeless tires.

Unmatched Durability and Long-Life Stamina

A full, box-section welded frame with front and rear box-section crossmembers gives every Bronco a durable, long-life backbone. Rugged channel bumpers are located for first contact with high ground. The gasoline tank is mounted between the frame siderails for greater safety. Skid plates are available for fuel tank and transfer case and are included with the optional auxiliary fuel tank for added protection. Integral steel skid strips stiffen the floor.

FORD MOTOR COMPANY LIFE-GUARD-DESIGN BRONCO SAFETY FEATURES . . . are standard and include dual hydraulic brake system with warning light, seat belts, padded instrument panel, outside mirror, windshield washers, variable-speed windshield wipers, padded sun visors, thick laminate safety plate glass windshield, turn indicators, backup lights, ICC 4-way emergency flasher, corrosion-resistant brake lines, safety-designed instrument panel and controls and many more.

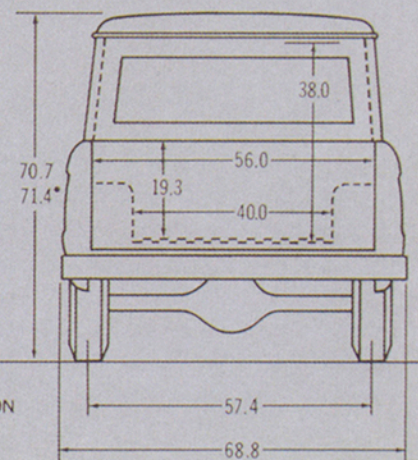
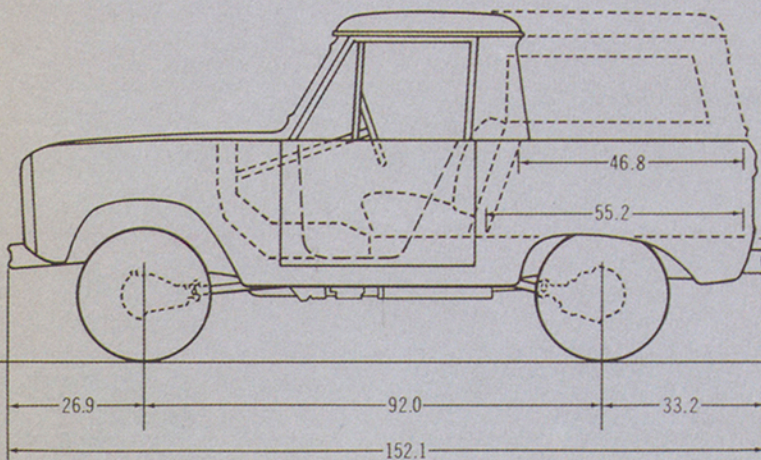
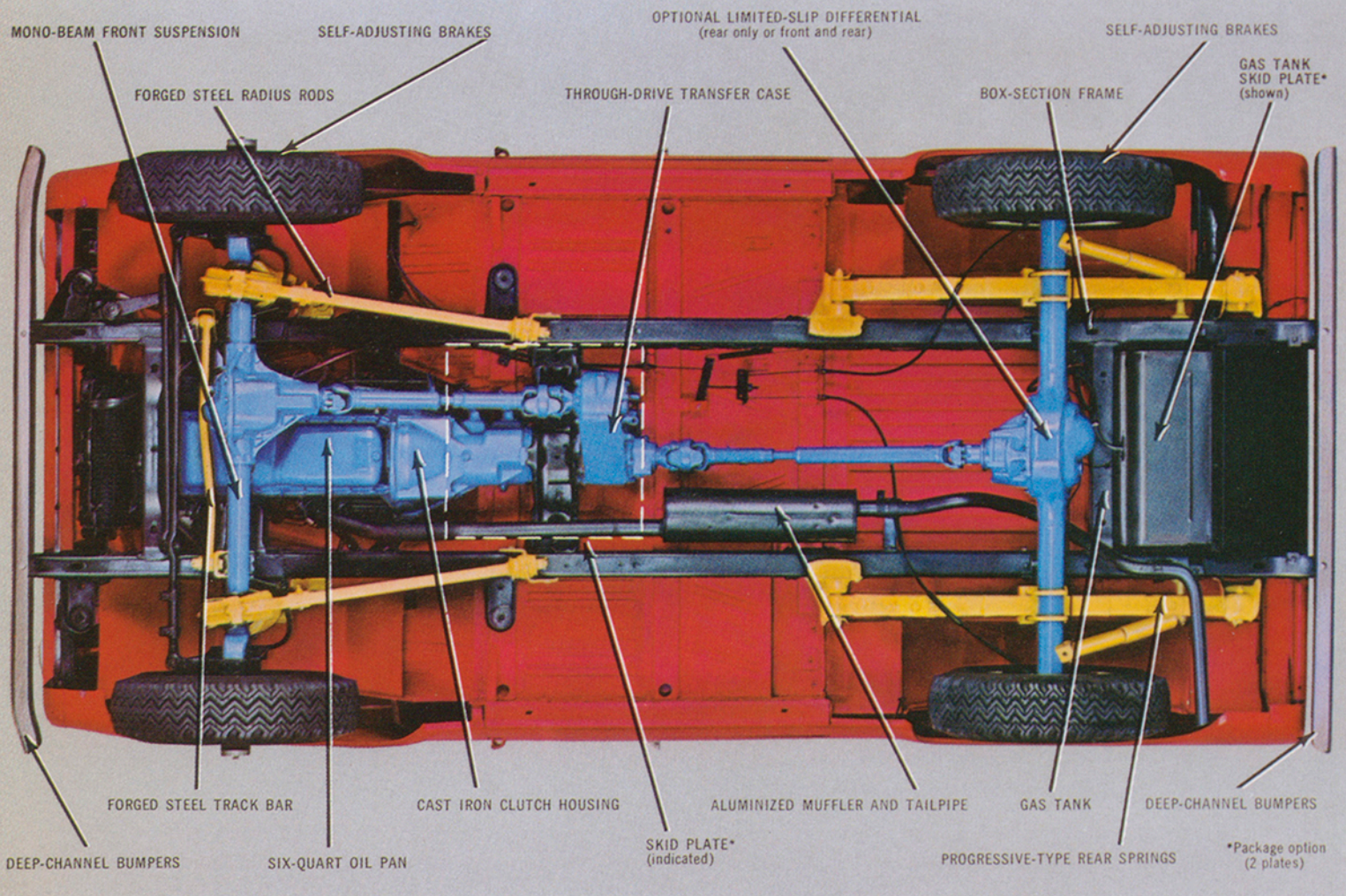

Bronco Offers Unlimited Versatility



FORD MOTOR COMPANY'S "3-Point Warranty Plan"

1. 5-year or 50,000-mile warranty on the power train.
2. 2-year or 24,000-mile warranty on complete vehicle.
3. Only one dealer certification per year regardless of how many miles you drive.

Ford Motor Company warrants to Ford Bronco owners that their selling Ford dealer (or if the owner is traveling or has moved, any Ford dealer) using genuine new Ford or Ford Authorized Reconditioned parts, will repair or replace, free of charge including related labor, the following parts which are found, in normal use and within the following time and mileage limits (whichever comes first), to be defective in either workmanship or materials: (a) any part within 24 months or 24,000 miles, and (b) Power Train parts within 5 years or 50,000 miles.

Power Train parts include: engine block, head and internal parts, water pump, intake manifold, transmission and transfer cases and internal parts, driveshafts, universal joints, differentials, and driving axles and their wheel bearings. Related items such as ignition, electrical, cooling, fuel and brake systems, engine or transmission controls or linkages, and clutch assembly are excluded. The owner is required to

obtain certain maintenance services* and, every 12 months, a written certification from a Ford dealer that he has presented evidence that such services have been performed.

The warranty does not apply to tires or tubes (adjustments are provided by tire companies), or to normal maintenance services or normal replacement of service parts such as filters, spark plugs, ignition points, wiper blades or brake or clutch linings, or to normal deterioration of soft trim and appearance items.

The warranty applies to vehicles normally operated in the U.S.A. and Canada.

*Every 6 months or 6,000 miles: change oil and oil filter; clean air cleaner, air filter and oil filler cap; check axle lube and transmission oil levels.

Every 12 months or 12,000 miles: replace air filter on closed crankcase ventilation systems; clean emission system and carburetor spacer; replace emission control valve and thermactor air filter.

Every 24 months or 24,000 miles: change engine coolant and check radiator hoses.

Every 36 months or 36,000 miles: replace air filter on open crankcase ventilation systems.

The specifications contained herein were in effect at the time this literature was approved for printing. Ford Division of Ford Motor Company reserves the right to discontinue models at any time or change specifications or design without notice and without incurring obligation. All options and accessories illustrated or referred to as optional or available in this literature are at extra cost. For the price of the model with the equipment you desire, see your Ford Dealer.

Every 1967 Bronco has been designed and quality-built to provide safer, more dependable service! Ford Motor Company Lifeguard-Design Bronco safety features are standard in every Bronco. These include a dual hydraulic brake system that permits the front or rear brakes to operate in the event that one sub-system fails. In addition, the transfer case T-bar shift lever provides a positive lock to help prevent the transfer case from jumping out of four-wheel drive.

YOU'RE AHEAD IN A FORD
ALL THE WAY!



* Reproduced under license agreement
with Ford Motor Company.
License # 5001 3-1-94