



SHIFT_

2013
GT-R®

Nissan. Innovation that Excites.™ NISSAN GT-R®

Shouldn't you drive something you love? Absolutely. And that's what inspires our innovation. We look at every part of your drive and ask how can we make this better, smarter and more fun? So when you get in your new GT-R, you'll feel how exciting the answers can be.

A 545-hp, 3.8-L twin-turbo-charged V6. Hand-assembled by a single craftsman in a clean-room environment.

On-the-fly dynamic control for instant adjustment of transmission, suspension and stability control.

Full underbody aerodynamics that create downforce and cool key powertrain components.

Advanced full-time All-Wheel Drive that provides up to 100% power to rear wheels for enhanced steering feel.

2013 NISSAN GT-R®



Scan this with your QR code-reader app to see a video of the 2012 GT-R at the Nürburgring or go to bit.ly/GTRvideo.



Follow us on:



SHIFT_

visit www.NissanUSA.com/GT-R

Facebook® is a registered trademark of Facebook, Inc. YouTube® is a registered trademark of Google Inc.

PRINTED IN USA.

INNOVATION
THAT REDEFINES.

It is the ultimate expression of a company famous for making passionate driver's cars. When introduced, the GT-R completely rewrote the rules. And then, after it had turned the world on its ear, we continued to improve it. Because we choose to lead. To create. To inspire. With an unmatched blend of technology and soul, it is a singular supercar, so intuitive anyone can drive it. So capable, it can be driven anytime and anywhere.* And for 2013, the GT-R returns even more powerful than before. Nissan. Innovation that Excites.™



A SUPERCAR
TO ITS VERY CORE.

UNCONVENTIONAL
AERODYNAMICS



UNRIVALED
PRESENCE



UNBELIEVABLE
PERFORMANCE



A SUPERCAR MUST:

- 1_ Achieve a top speed over 186.4 mph.
- 2_ Have a power-to-weight ratio of 8.8 lbs./hp.
- 3_ Lap the Nürburgring in under 8 minutes.

Before you rewrite the rules, you must establish them. So we boldly penned the absolute minimums the GT-R would need to reach. When the GT-R launched in 2009, we not only met our original goals – we shattered them.

And while some might have rested on their laurels, that's not the Nissan way. Instead, we immediately started looking for ways to further develop the GT-R. The results speak for themselves: a top speed of 196 mph, and an impressive power-to-weight ratio of 7.0 lbs./hp. During the development stages, the 2012 GT-R recorded a breathtaking 7-minute, 24.22-second lap of the Nürburgring!¹





PERFORMING ON THE WORLD STAGE.

In 2007, when the high-pitched battle cry of the 3.8-liter twin-turbo V6 pierced the cool, damp German morning air and posted an official 7-minute, 38-second lap, the entire world knew about it instantaneously. The GT-R had turned the fastest lap ever for a production car. Faster around the Nürburgring than even the Porsche 911 Turbo. But for team GT-R, it was just the beginning. In the next few years, Nissan improved its record each year. And

then, in September 2010, the 2012 GT-R sent another shock wave through the performance world with an unofficial time of 7 minutes, 24.22 seconds. While the weather would not allow an officially timed run, the GT-R showed again that it is always improving. The official run would have to wait for the next visit. But already, the engineers at Nissan were working on ways to go even faster.

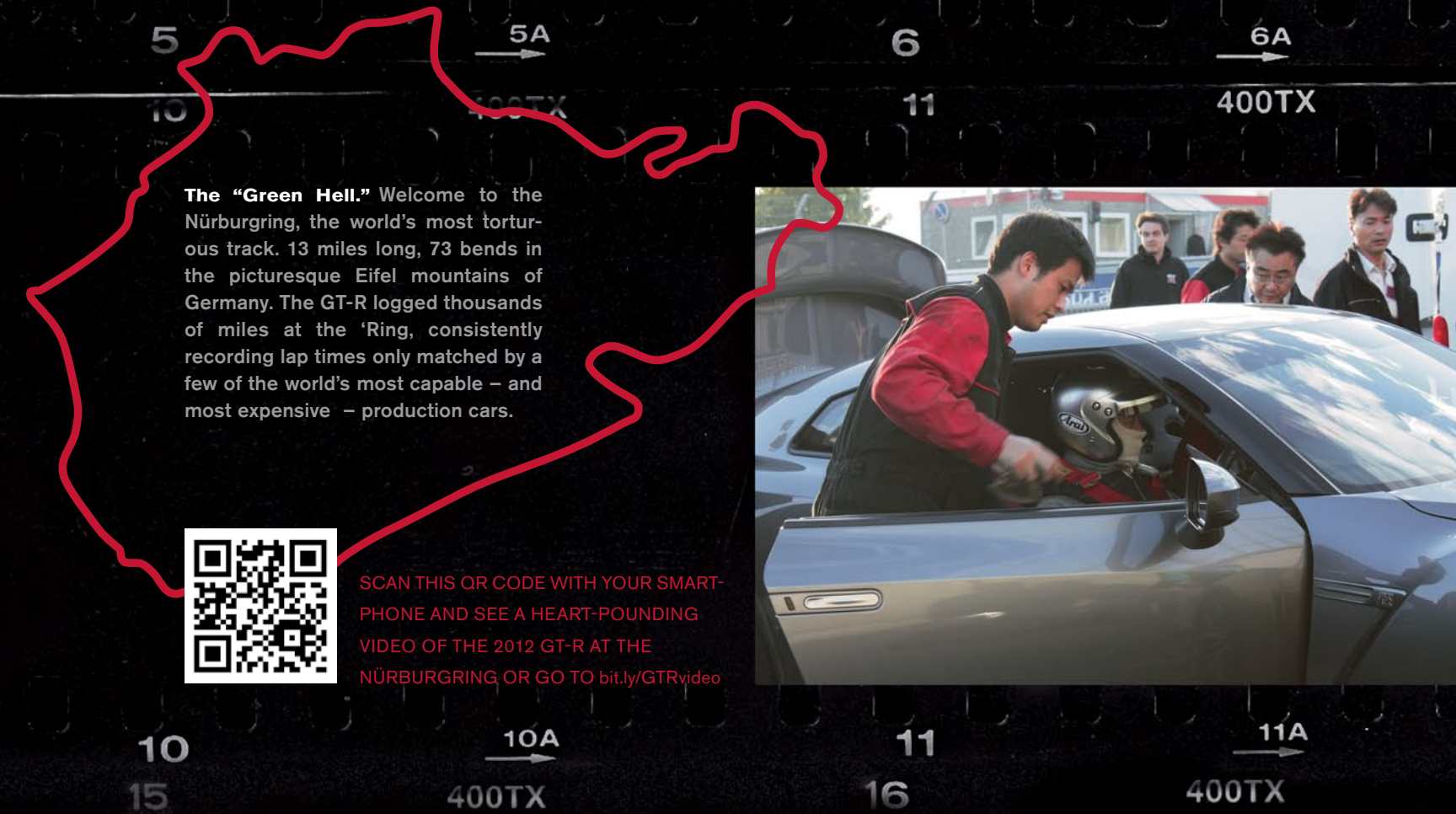

The "Green Hell." Welcome to the Nürburgring, the world's most torturous track. 13 miles long, 73 bends in the picturesque Eifel mountains of Germany. The GT-R logged thousands of miles at the 'Ring, consistently recording lap times only matched by a few of the world's most capable – and most expensive – production cars.



SCAN THIS QR CODE WITH YOUR SMARTPHONE AND SEE A HEART-POUNGING VIDEO OF THE 2012 GT-R AT THE NÜRBURGRING, OR GO TO bit.ly/GTRvideo



MASTERY AT YOUR FINGERTIPS
**FOR ROAD. OR TRACK. OR
 NEARLY ANYTHING IN BETWEEN.**

At the heart of the Nissan GT-R's anyone, anytime, anywhere¹ performance is an easy-to-use 3-mode system. Three switches allow for on-the-fly adjustment of specific performance parameters for the transmission, suspension and VDC stability control.² This is supercar performance with amazing flexibility at the touch of a switch.

	R-MODE	NORMAL MODE	SPECIAL MODE
Transmission	For maximum performance with the quickest shifts.	For maximum smoothness.	Save mode – For long-distance high-speed driving and gentler torque delivery for smooth driving on slippery surfaces.
Suspension	For high-performance cornering. The damping force of the shock absorbers is set for maximum vehicle performance.	For automatic electronic control of damping.	Comfort mode – The damping force of the shock absorbers is variably adjusted for more comfort.
VDC²	For ultimate performance. Adjusts front and rear wheel power distribution to enhance handling.	For daily driving. Controls brakes and engine output.	Off mode – Disengages the VDC system. ²

¹Driving is serious business and requires your full attention. At all times, obey traffic laws. Not intended for unpaved off-road use. Always wear your seat belt, and please don't drink and drive. ²VDC, which should remain on when driving except when freeing the vehicle from mud or snow, cannot prevent accidents due to abrupt steering, carelessness, or dangerous driving techniques. Always drive safely.

MAKING PERFORMANCE OUT OF THIN AIR.

For supercars, air is the enemy, to be avoided as much as possible. But Nissan took a unique philosophy to win this battle. Building on Nissan's extensive racing experience, the GT-R spent 2 years at the rolling-road wind tunnel at Group Lotus in Europe and 1.5 years in Yoshitaka Suzuka in Japan fine-tuning the secrets of bringing racecar aerodynamics to the street. Continuous development means that the 2013 GT-R enjoys an incredibly slippery 0.26 coefficient of drag, impressive downforce for traction and control, and superior airflow management and cooling of key components.

Rear spoiler creates downforce

Functional hood scoops assist cooling in engine compartment

Large grille opening with rounded edges optimizes cooling of engine, inter-coolers and running gear with minimum drag



Vent on the side of rear bumper helps manage airflow towards the rear of the vehicle

Vents at the back of the front fenders reduce pressure in the front wheel arches and help vent the brakes

Ridges at the corners of the front air dam enhance transition of airflow from front of GT-R to the sides

Out of sight, but not out of mind. With traditional vehicles, air hitting components underneath the vehicle creates drag – slowing the car and creating lift – reducing grip and traction. Because traditional wind tunnels leave out a key component in design – the effect of the airflow of the road moving under the car – Nissan tested the GT-R in a unique wind tunnel with a “rolling road” that moves beneath the vehicle. The result: a series of composite panels beneath the vehicle (a technique derived from racecars), that not only channels cooling air to the running gear, but also makes sure the underside remains clear of obstructions, creating downforce that literally pulls the car to the road.

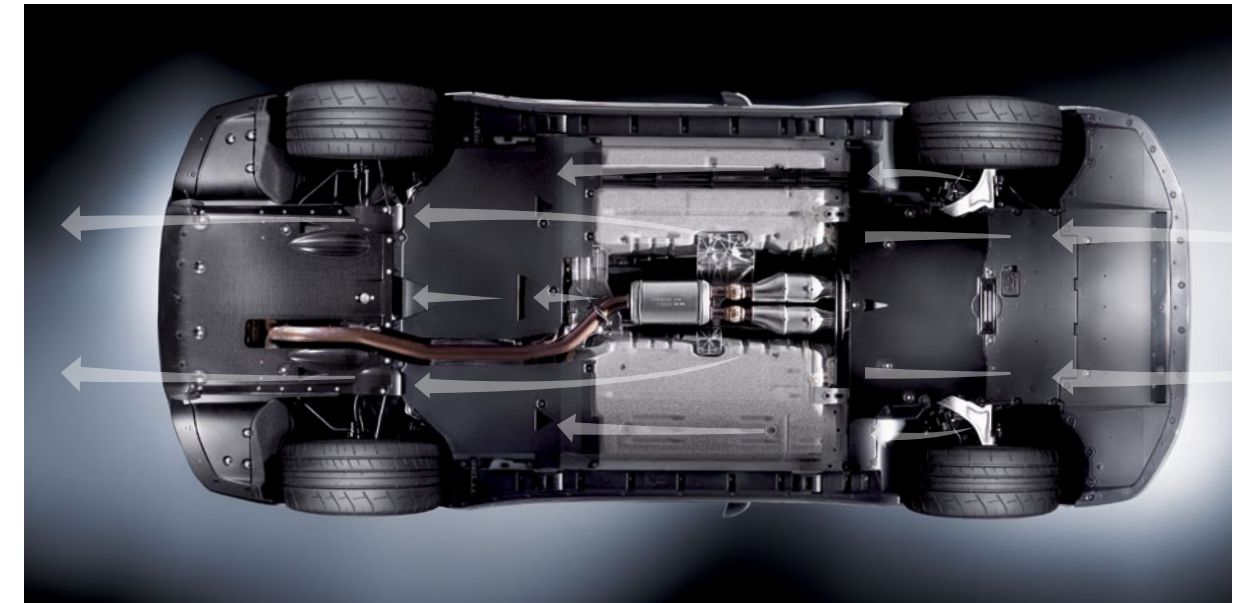

Rear diffuser helps drive the under-car flow. Large amounts of downforce are generated by increasing air speed underneath the vehicle.

Key components, including the exhaust, remain open to maximize cooling effect.

The smooth underbody at the front of the GT-R helps accelerate air underneath the vehicle for maximum cooling and front-end grip.



ONE MAN.
ONE ENGINE.

Each Nissan GT-R engine is hand-assembled by a single technician – one of only 8 allowed the honor – in a dust- and temperature-controlled clean room much like those used for Formula One racing engines. Once assembled, the engine spends an hour in bench testing and break-in, including running at redline for a rigorous 10 minutes straight, making it ready to give full performance when the GT-R is delivered to its owner.



Unconventional wisdom. Nissan challenged tradition at every point in the GT-R's development. While a large engine can be powerful, it can also be heavy and thirsty for fuel. Instead, the Nissan GT-R is powered by an ideally sized, twin-turbocharged 3.8-L V6. Enhanced for 2013, power has once again been increased to a prodigious 545 horsepower and 463 lb-ft of torque. To develop an engine so capable, no detail was overlooked: rather than traditional cast-iron liners, each cylinder features a unique plasma coating sprayed onto the cylinder walls. This advanced process greatly reduces friction, allowing the engine to spin more freely, reducing wear for added durability, and improving cooling – a uniquely brilliant way to build an engine to perform under brutal conditions.

An engine is an air pump. The better it breathes, the better it works. For maximum performance, the Nissan GT-R features a fully independent intake system for each bank of cylinders. With a special secondary air system that helps heat the catalysts more quickly, the Nissan GT-R is not only powerful, it runs so clean that it's been certified as an Ultra Low Emissions Vehicle (ULEV).

Location, location, location. By using a powerful twin-turbo V6 rather than a larger and heavier V8 or V12, the Nissan GT-R exploits its PM (Premium Midship) design for ultimate balance. In the PM design, much of the engine sits well back in the chassis behind the front axle – for crisper turn-in, quick steering response and overall balance. The lighter, more compact engine also pays dividends in performance and interior room.



Steering-column-mounted paddle shifters



Transmission settings: R-Mode, Normal and Save

Two clutches. No clutch pedal. The Nissan GT-R's 6-speed dual clutch transmission shifts incredibly quickly. How? Inside the transmission, there are separate clutches for the odd (1st, 3rd, 5th) and even (2nd, 4th, 6th) gears. When the car is in an odd-numbered gear, the adjacent even-numbered gear is "pre-selected" – ready to make the shift immediately. The transmission is so smart, it even "blips" the throttle on downshifts to match rpm. So even though your left leg may not get much exercise, you'll have tremendous fun shifting the GT-R.

IT SHIFTS THE WORLD OF TRANSMISSIONS IN JUST **0.15 SECONDS.**

The longer a shift takes, the less time power is being put to the ground. So for maximum acceleration, the GT-R's paddle-shifted 6-speed sequential dual-clutch transmission can snap off lightning-quick gear changes in just 0.15 seconds when in R-Mode – quicker than you can blink.

Ideally balanced. To achieve optimal front-to-rear weight distribution, the Nissan GT-R's clutches, transmission and transfer case are all mounted in the rear of the chassis, creating the world's first independent rear transaxle for an All-Wheel Drive vehicle.



Carbon-composite propeller shaft

Independent rear transaxle



IN THIS CORNER
CONSUMMATE BALANCE.

All for one. The Nissan GT-R's ground-hugging aerodynamics plus powerful brakes allow it to carry speed much later into the turn. But the real key to its quickness is the All-Wheel Drive's ability to put the power down much sooner in a corner. In contrast, as they approach the limit of cornering grip, many powerful Rear-Wheel Drive cars require the driver to wait before applying power until the exit of the corner, to avoid upsetting the handling of the car. The GT-R driver simply powers out of the corner sooner and therefore faster.¹



Premium blend. The Nissan GT-R's Premium Midship (PM) design allows another unique philosophy to be employed. Traditional thought says that a 50/50 weight distribution when the vehicle is static is ideal. Nissan engineers believe that what you really want is this ideal balance when in motion, so the GT-R carries a 53/47 static distribution that becomes a dynamic 50/50 weight distribution under acceleration, for superbly balanced handling.

¹Professional driver. Closed course. Obey all traffic laws, always drive safely and wear your seat belt. Damage resulting from racing, competitive driving, track and/or airstrip use not covered by warranty. See your New Vehicle Limited Warranty and Owner's Manual for proper vehicle operation and complete warranty details.

ADVANCED TO ITS VERY CORE.

For the GT-R's chassis, the extensive use of lightweight but super-strong aluminum and clever packaging of key powertrain components provide an ideal blend of strength, balance and control.

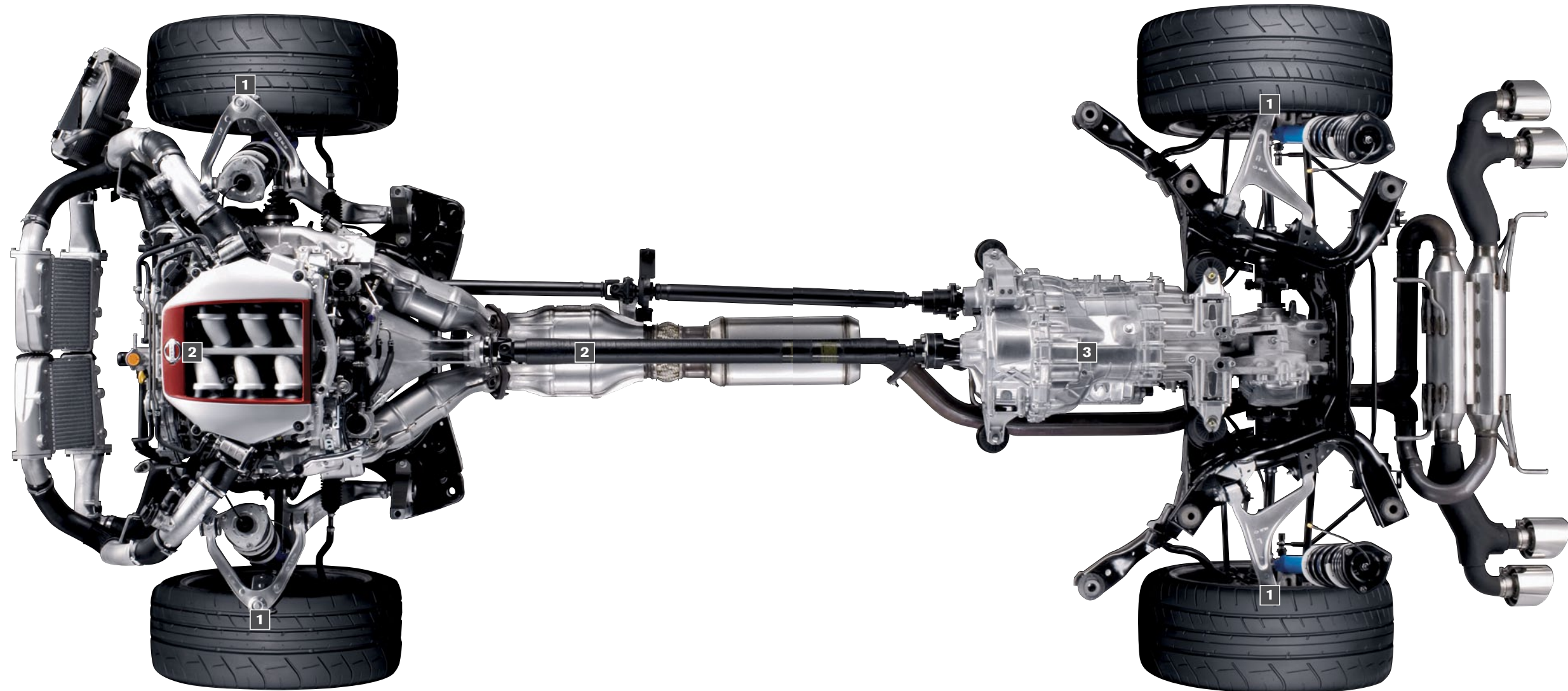

1_ Key suspension components and lightweight forged aluminum wheels reduce unsprung weight, allowing the suspension to respond more quickly to the road, and the steering to respond more quickly to driver input.

2_ By reducing rotating mass from items like a carbon-composite propeller shaft and lightweight engine components, the engine can spin more freely. The lightweight wheels also turn more easily, allowing quicker acceleration and braking.

3_ No area escaped scrutiny – even the differential and transmission were combined into a single casting to reduce vehicle weight.

Building a better body. To help ensure that the GT-R provides a rigid platform, Nissan engineers pioneered a unique hybrid body structure using high-strength steel, die-cast aluminum, carbon fiber and composite materials. Die-cast aluminum is lightweight yet extremely rigid. Instead of multiple sheet metal stampings welded together, the Nissan GT-R's front shock housing is a single die-cast aluminum structure that's lighter, stronger, and provides more accurate

fit of components, allowing for greater precision and control of the front suspension. A carbon-composite radiator crossmember helps to keep weight off the front wheels, for better handling, while a new carbon-fiber engine-chassis brace enhances stiffness. Below the chassis, durable, lightweight carbon fiber, polypropylene and fiberglass are used in the underbody tray to create aerodynamic downforce.



HUGE IN EVERY WAY.

To complement its greater horsepower and torque, the GT-R features awe-inspiring braking power. Look beyond the sheer size of the 15.4" front and 15.0" rear brake rotors, and you'll see that Nissan has brought some of the biggest ideas in racing to this extraordinary road car. The brakes feature 6-piston front and 4-piston rear calipers for stronger, more even clamping power – something you'd expect to see on an all-out competition machine. For extreme rigidity with light weight, the caliper is machined from a single one-piece "monoblock" of aluminum.

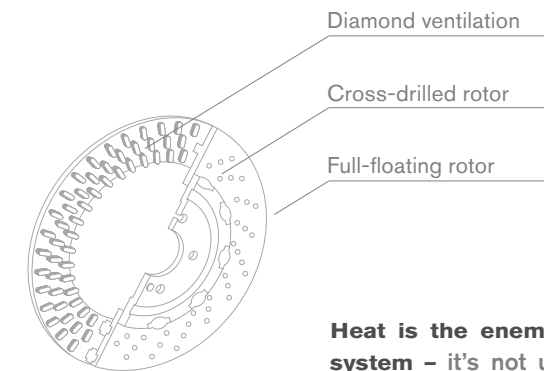

Heat is the enemy of any braking system – it's not uncommon to see the rotors of racecars glowing bright red. Along with cross-drilled rotors to help keep the Nissan GT-R's brakes cool, you'll find ingenious diamond-shaped ventilation ribs to pull away heat. The GT-R also benefits from a full-floating rotor – a race-bred technology. By allowing the outer disc to expand away from the hub under extreme heat, it reduces the tendency of the rotor to warp.

©Brembo is a registered trademark of Freni Brembo S.p.A.



DRIVEN PERFORMANCE

TO THE POWER OF FOUR.

The Nissan GT-R features one of the most advanced All-Wheel Drive systems ever used in a road car. Precise control of power to all four wheels combined with an equally advanced VDC stability control¹ system mean you have superior confidence and control. Anytime. Anywhere.²



Biased performance. Instead of the traditional 50/50 torque split between front and rear axles, the Nissan GT-R's electronically controlled All-Wheel Drive system is designed to provide up to 100% of available torque to the rear wheels, and can send up to 50% of torque to the front wheels as needed. This provides the steering feel and response of a Rear-Wheel Drive vehicle – the preferred choice of racers and serious enthusiasts – while still giving the added confidence and control that only an All-Wheel Drive vehicle can offer.

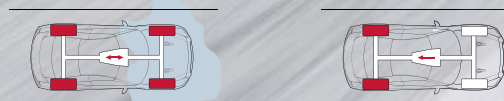

VDC that pulls for you. Most stability control systems cut engine power or apply the brakes when they sense a loss of control. Fine for the road, but slow going in competition conditions. While cornering with the Nissan GT-R's advanced Vehicle Dynamic Control (VDC) system in R-Mode, it actually sends more power to the appropriate wheels when it senses oversteer or understeer, helping to keep it on the steered course. A much quicker way to go in track conditions!

¹VDC, which should remain on when driving except when freeing the vehicle from mud or snow, cannot prevent accidents due to abrupt steering, carelessness, or dangerous driving techniques. Always drive safely. ²Driving is serious business and requires your full attention. At all times, obey traffic laws. Not intended for unpaved off-road use. Always wear your seat belt, and please don't drink and drive.

STREET WISE.

Pure engineering brilliance allows the Nissan GT-R's suspension to deliver world-class performance in conditions that send other supercars back for remedial studies. Whether it's R-Mode, designed for track driving, Normal Mode that's aggressive without being punishing, or Comfort Mode to smooth out city streets and tame freeway hop, advanced technology combines with lightweight suspension components to make the GT-R responsive, refined and exhilarating.

Smart shocks. The Bilstein® DampTronic® system uses computerized control to continually adjust shock absorber damping. It constantly monitors 11 elements, including vehicle speed, lateral acceleration, torque, engine rpm and braking behavior to help provide the ideal ride/handling balance. To match the precision of the Nissan GT-R's other suspension components, high-accuracy progressive-rate springs were developed and manufactured to extremely high tolerances.



PASSIONATELY ASSEMBLED. RIGOROUSLY TESTED.

From the single craftsman building the engine to the technician hand-fitting the chassis components. The hand-polishing of the body to the on-track test drive before it's delivered. Every Nissan GT-R bears the personal touch of some of the most highly trained car enthusiasts on the planet and is put through the paces to meet our extremely high standards.

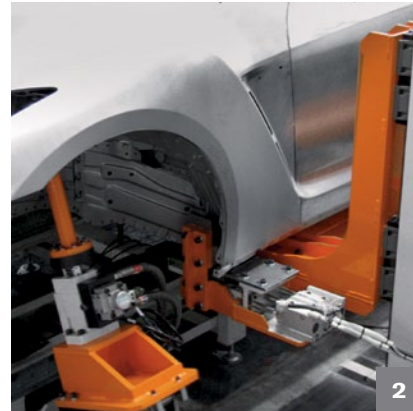

1_ Every GT-R receives a high degree of hand-assembly and finishing. **2_** Vibration testing, laser measurements, and comprehensive inspections by experienced specialists are performed to ensure long-term functionality and to maintain the highest levels of accuracy and precision during assembly. **3_** After a hand-finishing of the body panels and careful polishing, the GT-R is ready.

Born to perform. Before it is delivered, each Nissan GT-R receives a thorough 9-lap break-in run at Tochigi test track to evaluate and break in key components, including the engine, brakes, transmission and suspension. While it may seem like great lengths to go to, it's the best way to ensure that every GT-R will offer its full measure of groundbreaking performance from the very beginning – and for many years to come.

LAP 1_ Brake quenching

LAP 2_ Brake quenching

LAP 3_ Brake quenching

LAP 4_ Brake bed-in

LAP 5_ Transmission break-in

LAP 6_ Transmission break-in,
boost pressure check

LAP 7_ Transmission contact
(sudden start)

LAP 8_ Reducing friction
of suspension

LAP 9_ Reducing friction
of suspension



BEEL AIRBAG

PERFORMANCE ARTIST.



Special attention to ergonomics means the Nissan GT-R feels familiar the moment you sit down – all gauges, including the Multi-Function Display system, are on the same plane, making for an easy scan, while instruments are large, clear and simple for maximum legibility.

Intuitive by design. Switchgear – from the door to the steering-wheel-mounted controls to audio, climate control and the three setup switches – are at a similar height and are grouped by shape and function.

A PURE, UNDILUTED DRIVING EXPERIENCE
COMBINED WITH MODERN CONVENIENCE.

VIRTUAL MEETS
REALITY.

Like everything else in the GT-R, Nissan rethought the way the driver receives information. Who are the best in the world at providing the most data, the quickest? Video game developers. That's why Polyphony Digital,® creators of the world-famous Gran Turismo® driving game for Sony PlayStation® – and huge Nissan GT-R fans in their own right – were asked to collaborate in the design of the GT-R's Multi-Function Display system. The result is engaging and informative – providing quick readability combined with the flexibility of multiple customizable displays. Very real-world, yet exceptionally fun, too. Play on.



Seven factory preset screens give you quick access to key driving information, including acceleration, braking, steering, gear position and lap time.



Four customizable performance screens are designed to let the driver organize key information to their personal tastes. Choose from a variety of engine performance and efficiency parameters to cornering and acceleration/braking G-forces. It can even keep a driving record of your laps on a track, to analyze and improve your performance.

©Gran Turismo is a registered trademark of Sony Computer Entertainment America Inc. ®PlayStation and Polyphony Digital are registered trademarks of Sony Computer Entertainment America Inc.



BORN TO PERFORM.

The 11-speaker Bose® audio system was designed along with the vehicle itself. The die-cast aluminum structures in the doors and behind the rear seats not only make the car incredibly rigid, they're also an ideal way to mount speakers for optimum sound. Even the dual subwoofers between the rear seats were developed especially for the GT-R, angled specifically to work in concert with the sounds of the car itself, and employ the trunk as a giant bass enclosure.



- iPod® or flash drive connectivity via USB input^{1,2}
- Plays MP3/WMA CDs or DVDs
- DVD video playback
- SiriusXM™ Satellite Radio³
- Streams music from any compatible device via Bluetooth® wireless technology⁴



Fast in so many ways. A supercar shouldn't just be great on the open roads – it should also help you find them. With Nissan GT-R's touch-screen navigation system⁵ with voice recognition and a high-res screen, the world is at your command. It features a hard drive-based system for quick response, while improved NavTraffic³ advisories in real time help keep you ahead of the crowd. You can even keep track of the weather with NavWeather³ or get trusted restaurant ratings and reviews with Zagat Survey®. And with DVD playback capability and a USB iPod® input², the entertainment will have no problem keeping pace¹. For 2013, the system includes a RearView Monitor, so even parking is a quick and easy affair.⁶

¹Always give your full attention to driving. Avoid operating your iPod in such a way that you can be distracted during vehicle operation. See dealer for details. ²iPod is a registered trademark of Apple, Inc. All rights reserved. iPod not included. ³Driving is serious business and requires your full attention. Do not operate any devices connected to the USB or auxiliary audio input jack while driving. ⁴Required SiriusXM Satellite Radio, NavTraffic and NavWeather subscriptions sold separately after trial period. Installation costs, one-time activation fee, other fees and taxes will apply. NavTraffic available in select markets. Services available only to those 18 or older in the 48 contiguous states and D.C. Fees and programming subject to change. Subscriptions governed by Customer Agreement available at siriusxm.com. ©2012 Sirius XM Radio Inc. Sirius, XM and all related marks and logos are trademarks of Sirius XM Radio Inc. ⁵Availability of specific features is dependent upon the phone's Bluetooth® support. Please refer to your phone owner's manual for details. Bluetooth word mark and logos are owned by Bluetooth SIG, Inc., and any use of such marks by Nissan is under license. ⁶Never program while driving. GPS mapping may not be detailed in all areas or reflect current road regulations. ⁷Parking aid/convenience feature. Cannot completely eliminate blind spots or warn of moving objects. May not detect every object. Always check surroundings before moving vehicle. Not a substitute for proper backing procedures. Always turn to check what is behind you before backing up. ⁸Bose is a registered trademark of The Bose Corporation. ⁹Zagat Survey is a registered trademark of Zagat Survey, LLC Ltd.

GT-R BLACK EDITION

DESIGNED FOR THE PURIST.

Redefining passion. The connection between driver and machine gets even more intimate with the GT-R Black Edition's supremely supportive, Recaro® leather-appointed front seats. Matching red leather on the door pulls and the shift lever are a perfect complement to the contrasting panels on the seats, creating a driver's environment that is as inspiring to look at as it is to employ. Equally exhilarating, the Black Edition rides on unique, 6-spoke special lightweight forged aluminum wheels, measuring 20" x 9.5" in front and 20" x 10.5" at the rear. For 2013, a new dry carbon-fiber composite rear spoiler ensures that the final impression you leave will be a most memorable one.†



Performance art. The Black Edition's rear spoiler is as breathtaking to the eye as it is slippery to the wind. Handmade in a limited monthly production run, the lightweight dry carbon fiber is also incredibly strong. To make it a feast for the senses, a special coating allows you to feel the weave of the carbon fiber.†



Specifications

Engine	Premium	Black Edition
VR38DETT – 3.8-liter twin-turbocharged 24-valve V6		
– Horsepower – 545 horsepower @ 6,400 rpm		
– Torque – 463 lb-ft of torque @ 3,200–5,800 rpm		
– Cylinder bore x stroke – 95.5 x 88.4 mm		
– Top speed – 196 mph		
– Emissions – 50 State LEV2/ULEV		
Continuously Variable Valve Timing Control System (CVTCS)		
– on intake valves		
Aluminum cylinder block with high-endurance/low-friction		
– plasma-sprayed bores		
Aluminum pistons		
Nissan Direct Ignition System with iridium-tipped spark plugs		
Electronic drive-by-wire throttle		
Pressurized lubrication system with thermostatically		
– controlled cooling and magnesium oil sump		
Fully symmetrical dual intake and low back-pressure		
– exhaust systems		
Secondary air intake system to rapidly heat catalysts to peak		
– cleaning efficiency		
Special 50:50 coolant mix		

Drivetrain	Premium	Black Edition
ATTESA E-TS® All-Wheel Drive (AWD)		
Rigid, lightweight carbon-composite main propeller shaft		
Electronic Traction Control System (TCS)		
High-performance 1.5-way mechanical limited-slip rear differential		
Advanced Vehicle Dynamic Control (VDC) ¹ with three		
– driver-selectable modes (Normal, R-Mode, Off)		
Hill start assist		

Transmission	Premium	Black Edition
Dual-clutch 6-speed transmission with three driver-selectable		
– modes (Normal, R-Mode, Save)		
Fully automatic shifting or full sequential manual control via		
– steering-column-mounted paddle shifters		
Downshift Rev Matching		

Brakes	Premium	Black Edition
Nissan/Brembo® braking system – 4-wheel disc brakes,		
– 15.4" front and 15.0" rear two-piece floating-rotors		
Super-rigid 6-piston front/4-piston rear monoblock calipers		

Suspension/Steering	Premium	Black Edition
Front suspension – double-wishbone with aluminum arms		
Rear suspension – multi-link with aluminum arms		
Bilstein® DampTronic® suspension system with three driver-		
– selectable modes (Normal, R-Mode, Comfort)		
Hollow front and solid rear stabilizer bars		
Carbon-fiber engine chassis brace		
Vehicle-speed-sensitive power steering		
2.4 steering-wheel turns lock-to-lock		

■ Standard

☒ Part of Cold Weather Package

Wheels/Tires	Premium	Black Edition
Super-lightweight forged-alloy RAYS® wheels:		
– 20" x 9.5" (front) 20" x 10.5" (rear)		
Special black super-lightweight forged-alloy RAYS® wheels:		
– 20" x 9.5" (front) 20" x 10.5" (rear)		
Exclusively developed tires, ² nitrogen-filled at factory:		
– 255/40ZRF20 (front) 285/35ZRF20 (rear)		
Dunlop® SP Sport MAXX GT600 DSST CTT high-		
– performance run-flat tires ²		
Dunlop® SP Sport 7010 all-season run-flat tires ²		

Body Construction/Aerodynamics	Premium	Black Edition
Premium Midship (PM) platform with hybrid unibody		
Aluminum hood, trunk lid and outer door skins		
Die-cast aluminum front shock towers and inner		
– door structures		
Carbon-composite front crossmember/radiator support		
Coefficient of drag – 0.26		
Body-color rear spoiler		
Dry carbon-fiber rear spoiler ³		

Exterior Features	Premium	Black Edition
High Intensity Discharge (HID) auto-on/off headlights;		
– LED Daytime Running Lights; LED taillights and brake lights		
Dual heated body-color power outside mirrors		
Power folding outside mirrors		

Audio/Navigation/Performance Monitor	Premium	Black Edition
Bose® AM/FM/CD audio system with 11 speakers,		
– including dual subwoofers		
MP3/WMA CD and DVD video playback capability		
SiriusXM™ Satellite Radio ⁴		
USB connection port for iPod® interface and other		
– compatible devices ^{5,6}		
Streaming audio via Bluetooth® wireless technology ⁷		
Steering wheel-mounted audio controls and speed-sensitive		
– volume control		
Nissan Hard Drive Navigation System with voice recognition ⁸		
NavTraffic, NavWeather ⁴ and Zagat Survey® reviews		
Driver-configurable Multi-Function Display system		
RearView Monitor ⁹		

Comfort/Convenience	Premium	Black Edition
Nissan Intelligent Key® with Push Button Ignition		
Bluetooth® Hands-free Phone System ⁷		
HomeLink Universal Transceiver		
Dual Zone Automatic Temperature Control (ATC)		
In-cabin microfilter		
Power front windows with one-touch auto-up/down		
Power door locks with auto-locking feature		
Remote keyless entry with trunk release		
Cruise control with steering-wheel-mounted controls		
Tilt and telescoping steering column with integrated gauges		
Variable intermittent flat-blade speed-sensitive windshield wipers		

Comfort/Convenience (continued)	Premium	Black Edition
Dual illuminated visor vanity mirrors		
Auto-dimming inside rearview mirror		
12-volt DC power outlets (2)		

Seating/Appointments	Premium	Black Edition
Leather-appointed front seats with synthetic suede inserts		
Black/Red Recaro® leather-appointed front seats		
8-way power driver's seat		
Heated front seats		
Black/Red interior treatment		
Leather-appointed steering wheel and gearshift knob		
Aluminum-trimmed pedals		

Safety/Security	Premium	Black Edition
Nissan Advanced Air Bag System (AABS) with dual-stage		
– supplemental front air bags, seat belt sensors and occupant-		
– classification sensor ¹⁰		
Driver and front-passenger side-impact supplemental air bags		
– and roof-mounted curtain side-impact supplemental air bags ¹⁰		
Front seat belts with pretensioners and load limiters		
LATCH System (Lower Anchors and Tethers for CHildren)		
Zone Body construction with front and rear crumple zones		
Hood-buckling creases and energy-absorbing steering column		
4-wheel Anti-lock Braking System (ABS) and Electronic Brake		
– force Distribution (EBD)		
Tire Pressure Monitoring System (TPMS)		
Nissan Vehicle Immobilizer System and Vehicle Security System		

Package

☒ **Cold Weather Package**

- Dunlop® SP Sport 7010 all-season run-flat tires²
- Special 50:50 coolant mix

ACCESSORIZE.



Vehicle Cover (Silver or Black)



Premium Sport Floor Mats with Carbon-fiber Inserts

Dimensions/Capacities

Exterior Dimensions – Inches			
Wheelbase	109.4	Overall height	54.0
Overall length	183.9	Track width (front/rear)	62.6/63.0
Overall width	74.9		

Interior Dimensions – Inches			
Front/rear			
Head room	38.1/33.5	Hip room	54.7/44.9
Leg room	44.6/26.4	Shoulder room	54.3/50.0

Capacities	
Interior passenger volume (cu. ft.)	79.0
Cargo volume (cu. ft.)	8.8
Fuel tank (gals.)	19.5

Curb Weights – Lbs.		
	Premium	Black Edition
Base total	3,829	3,818
Weight distribution	53/47	53/47

2013 EPA Fuel Economy Estimates	
City/highway	16/23
– Actual mileage may vary with driving conditions – use for comparison only.	

Nissan's philosophy toward the environment, "Seeking a symbiosis of people, vehicles and nature," describes our ideal for a sustainable mobile society, now and in the future. We launched the Nissan Green Program with specific objectives to realize this goal, and we are pursuing it energetically. For more information, log on to NissanUSA.com/green



Every Genuine Nissan Accessory is:

- Custom-fit, custom-designed and durability-tested.
- Backed by Nissan's 3-year/36,000-mile limited warranty.
- Can be financed with vehicle purchase, for just a few dollars a month.

See your Nissan dealer for details, or go to:

NissanUSA.com/accessories

¹Bilstein and DampTronic are registered trademarks of ThyssenKrupp Bilstein GmbH. ²The Bluetooth word mark and logos are owned by Bluetooth SIG, Inc., and any use of such marks by Nissan is under license. ³Bose is a registered trademark of The Bose Corporation. ⁴Brembo is a registered trademark of Freni Brembo S.p.A. ⁵Dunlop is a registered trademark of DNA Ltd. Corporation. ⁶iPod is a registered trademark of Apple, Inc. All rights reserved. iPod not included. ⁷RAYS is a registered trademark of RAYS Engineering. ⁸Recaro is a registered trademark of Recaro Beteiligungs-GmbH Corporation. ⁹Zagat Survey is a registered trademark of Zagat Survey, LLC Ltd.

¹⁰VDC, which should remain on when driving except when freeing the vehicle from mud or snow, cannot prevent accidents due to abrupt steering, carelessness, or dangerous driving techniques. Always drive safely. ¹¹Always use appropriate tires for weather conditions. See Owner's Manual for details. Failure to use appropriate tires could cause an accident resulting in serious injury or death. ¹²Dry carbon-fiber requires specific maintenance. Please see your Owner's Manual for details. ¹³Required SiriusXM Satellite Radio, NavTraffic and NavWeather subscriptions sold separately after trial period. Installation costs, one-time activation fee, other fees and taxes will apply. NavTraffic available in select markets. Services available only to those 18 or older in the 48 contiguous states and D.C. Fees and programming subject to change. Subscriptions governed by Customer Agreement available at siriusxm.com. ©2012 Sirius XM Radio Inc. Sirius, XM and all related marks and logos are trademarks of Sirius XM Radio Inc. ¹⁴Always give your full attention to driving. Avoid operating your iPod® in such a way that you can be distracted during vehicle operation. See dealer for details. ¹⁵Driving is serious business and requires your full attention. Do not operate any devices connected to the USB or auxiliary audio input jack while driving. ¹⁶Availability of specific features is dependent upon the phone's Bluetooth® support. Please refer to your phone Owner's Manual for details. The Bluetooth word mark and logos are owned by Bluetooth SIG, Inc., and any use of such marks by Nissan is under license. ¹⁷Never program while driving. GPS mapping may not be detailed in all areas or reflect current road regulations. ¹⁸Parking aid/convenience feature. Cannot completely eliminate blind spots or warn of moving objects. May not detect every object. Always check surroundings before moving vehicle. Not a substitute for proper backing procedures. Always turn to check what is behind you before backing up. ¹⁹Air bags are only a supplemental restraint system; always wear your seat belt. Even with the occupant-classification sensor, rear-facing child restraints should not be placed in the front-passenger's seat. Also, all children 12 and under should ride in the rear seat properly secured in child restraints, booster seats, or seat belts according to their size. Air bags will only inflate in certain accidents. See your Owner's Manual for more details.

PERFECTION TO THE NTH DEGREE.

A craftsman uses both hands and eyes to inspect the body of a Super Silver GT-R. To bring out any possible imperfections, three different light sources, including fluorescent, halogen and diffused flood lighting, are used to see various types of surface qualities in the paint as if it were at night, daylight or simply under intense scrutiny.

Jet Black GAG



Super Silver KAB (extra-cost option)



Gray Leather-
appointed/
Synthetic Suede
(GT-R Premium
model only)



Gun Metallic KAD



Solid Red A54



Black Leather-
appointed/
Synthetic Suede
(GT-R Premium
model only)



Deep Blue Pearl RAY



Pearl White QAB



Black/Red Recaro®
Leather-
appointed Seat
(GT-R Black
Edition only)



Black Edition available in all GT-R colors.

Nissan Motor Acceptance Corporation. Whether you're buying or leasing, you'll find attractive rates and flexible terms to make your purchase more accessible.

New Vehicle Limited Warranties. Protection for your new Nissan includes 3-year/36,000-mile basic coverage and 5-year/60,000-mile powertrain coverage. Terms, conditions and exclusions apply. See Warranty Information Booklet for complete details.

Security+Plus.® For additional peace of mind, a variety of extended service plans lets you tailor the coverage to your driving habits.

Maintenance+Plus.® This extended plan ensures your Nissan will receive up to 17 different services and over 33 different inspection items at each visit, using the most up-to-date diagnostic equipment available.

Genuine Nissan Parts. When it comes time for service, any necessary replacement parts will be made using Genuine Nissan new or remanufactured parts, or Nissan-approved parts. And they're the only parts to carry Nissan's factory-backed limited warranty.

This brochure is intended for general descriptive and informational purposes only. It is subject to change and does not constitute an offer, representation or warranty (express or implied) by Nissan North America, Inc. Interested parties should confirm the accuracy of any information in this brochure as it relates to a vehicle directly with Nissan North America, Inc. before relying on it to make a purchase decision. Nissan North America, Inc. reserves the right to make changes, at anytime, without prior notice, in prices, colors, materials, equipment, specifications, and models and to discontinue product development and other pre- and post-production factors, actual vehicle, materials and specifications may vary from this brochure. Some vehicles shown with optional equipment. See the actual vehicle for complete accuracy. Availability and delivery times for particular models or equipment may vary. Specifications, options and accessories may differ in Hawaii, U.S. territories and other countries. For additional information on availability, options or accessories, see your Nissan dealer or contact Nissan North America, Inc.

*Recaro is a registered trademark of Recaro Beteiligungs-GmbH Corporation. At NissanUSA.com, you'll find virtual product demonstrations, a way to "build your own Nissan," a dealer locator, and more information about key Nissan support services. Or if you'd prefer, call **1-800-NISSAN-3** for answers to specific questions about GT-R or any other Nissan vehicle. The Nissan names, logos, product names, feature names, and slogans are trademarks owned by or licensed to Nissan Motor Co. Ltd. and/or its North American subsidiaries. **Always wear your seat belt, and please don't drink and drive.** ©2012 Nissan North America, Inc. *13 GT-R. 1312968N-4/12 40M CGI