

2012 **SUPER DUTY**[®]





AMERICA'S MOST CAPABLE PICKUP.¹

Tested-tough powertrains – designed, engineered and built by Ford – enable F-Series Super Duty[®] to give you class-leading fuel economy,² plus the best horsepower and torque.¹ It's ready to get the job done when no one else can, thanks to best-in-class maximum towing and payload capacities.¹ It even helps increase your confidence while towing with standard trailer sway control. No wonder F-Series has been America's best-selling truck for 34 years.

F-350 LARIAT Crew Cab 4x4. Dark Blue Pearl/Sterling Gray two-tone. Available equipment.

¹Best-in-class maximum payload and towing when properly equipped. Class is Full-Size Pickups over 8,500 lbs. GVWR vs. 2011/2012 competitors.

²Based on Ford drive-cycle tests of comparably equipped 2011 Ford and 2010/2011 competitive models.



2012 SUPER DUTY[®] ford.com

BEYOND HEAVY DUTY. THIS IS SUPER DUTY.®





OUTWORKS ALL THE REST.

This truck endured more torture testing than any generation of Ford Truck before it – including over 10 million cumulative miles on the most tested Power Stroke® diesel engine ever. A world-class team put this Super Duty® through a groundbreaking battery of computer simulations, lab and real-world tests – running it for thousands of hours on end in extreme conditions. Scorching heat. Bitter cold. Loaded to the max. Up the steepest grades. All to confirm that this truck is far more than the sum of its parts.

Super Duty is built to be the best – bringing you the best diesel and gas fuel economy of any truck in its class¹ – plus lots of other capabilities and features only Ford can deliver.

Best in Class

- Fuel Economy: Diesel and Gas
- Max. Horsepower and Torque: Diesel and Gas
- Max. Conventional Towing: 17,500 lbs.²
- Max. 5th-Wheel Towing: 24,500 lbs.²
- Max. Payload: 7,110 lbs.²

Class Exclusives

- Live-Drive Power TakeOff (PTO)³
- 5th-Wheel/Gooseneck Trailer Tow Prep Package³
- Standard Trailer Sway Control on both SRW and DRW
- LCD Productivity Screen³
- Standard Safety Canopy® System
- Tailgate Step³

F-350 LARIAT Crew Cab 4x4. Golden Bronze/Pale Adobe two-tone. Available equipment.

¹Class is Full-Size Pickups over 8,500 lbs. GVWR. Based on Ford drive-cycle tests of comparably equipped 2011 Ford and 2010/2011 competitive models.
²When properly equipped vs. 2011/2012 competitors. 24,500 on F-450 Pickup. 7,110 on F-350 DRW Regular Cab 4x2. ³Available feature.



2012 SUPER DUTY® ford.com



LARIAT ADVANCES YOUR POSITION.

Super Duty® LARIAT puts you in charge and at ease behind the wheel, so you're always ready to tackle the mission of the day. Leather-trimmed, 10-way power-adjustable front bucket seats and power-adjustable pedals help drivers of all sizes feel right at home. Dual-zone electronic automatic temperature control means you can maintain your climate-control independence from your front passenger. And to help keep your view clear at all times, the power-sliding rear window now includes defrost.



DIESEL BEATS THE COMPETITION 3 TIMES OVER.

The 6.7L Power Stroke® V8 Turbo Diesel – designed, engineered and built by Ford – helps this Super Duty® deliver up to a 20% improvement in fuel economy over the previous generation, making it the best in its class! It also gives you best-in-class horsepower and torque. We're talking 400 hp and a massive 800 lb.-ft. of torque. That's a game-changing combination. And this B20-capable engine has already proven itself in over 10 million miles of cumulative testing. It's the most tested Power Stroke diesel engine ever.

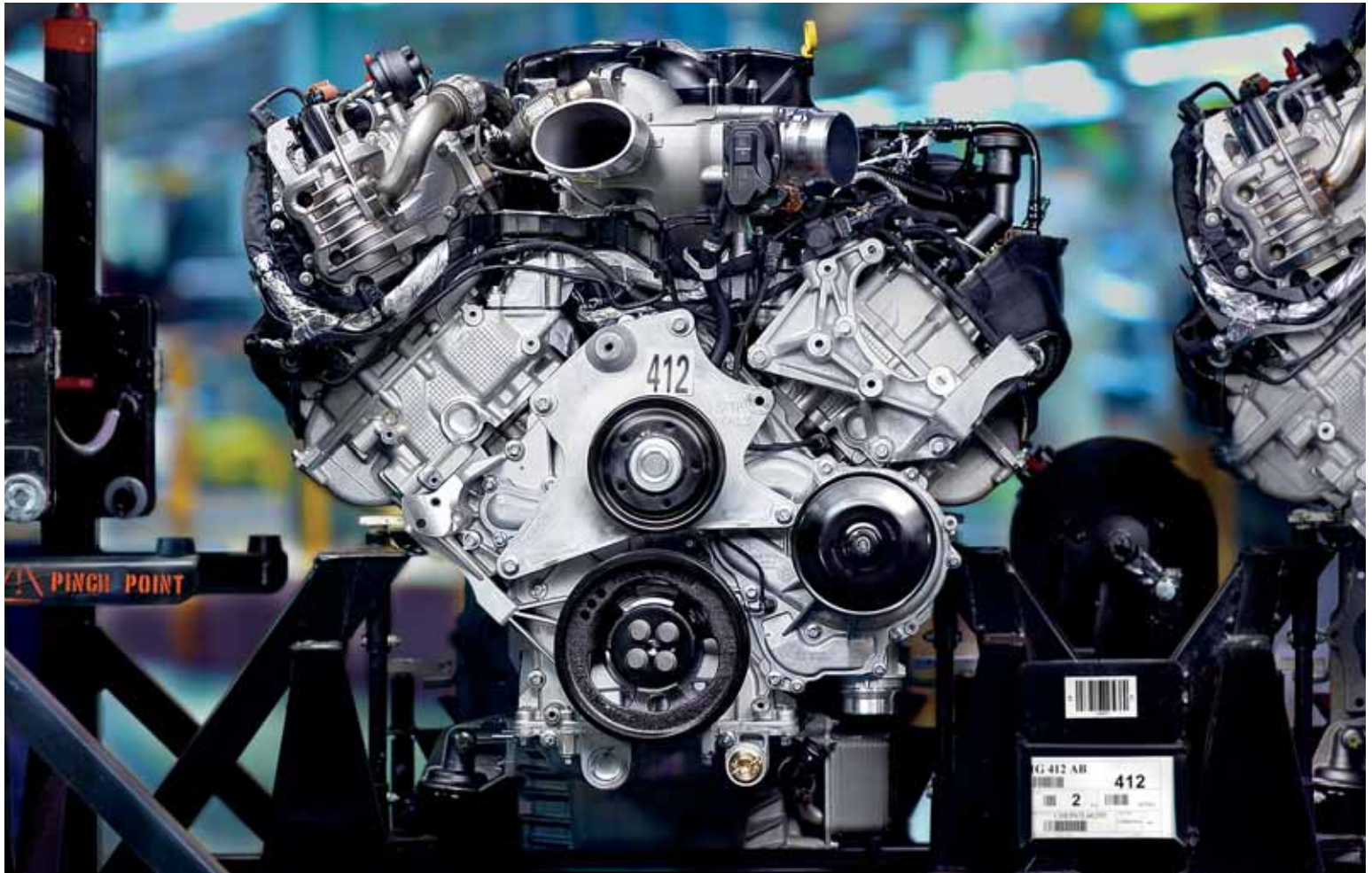

Delivers maximum power quickly. The diesel engine's class-exclusive single-sequential turbocharger features the compact, efficient design of a dual-sided compressor wheel.

Helps maintain the peace. With its notably quiet, refined sound, our diesel produces the lowest NVH in the class – the result of meticulous attention paid to the combustion system, engine block and turbocharger designs.

Powers upfits anytime the engine's running. Whether you're in motion or at a complete stop, you can power your upfits with the diesel and our class-exclusive live-drive power takeoff (PTO) provision.² It keeps the job going with an output gear linked directly to the engine crankshaft.

Cleanest Super Duty diesel ever. This engine utilizes industry-proven technology and innovative Ford strategies to meet the latest federal emissions standards – reducing nitrogen oxide (NOx) levels by more than 80% compared to the previous generation diesel. For your part, just watch for a low diesel exhaust fluid (DEF) alert in the vehicle's message center, then locate the blue DEF fill cap next to your green diesel fuel cap and replenish the DEF supply. The reservoir holds 5 gallons of Ford-approved DEF, which can be purchased from your Ford Dealer or other authorized retailers.

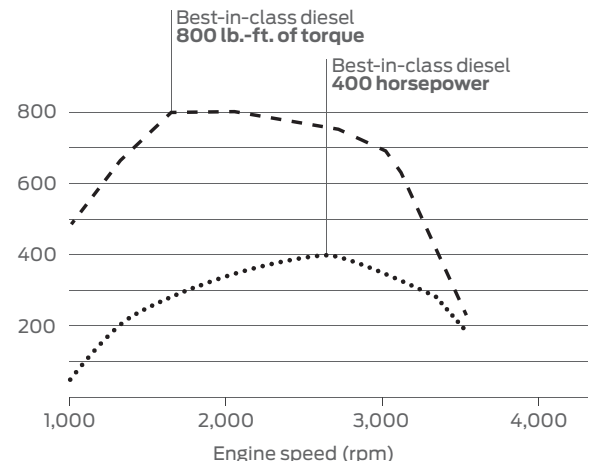

¹Based on Ford drive-cycle tests of comparably equipped 2011 Ford and 2010/2011 competitive models. ²Available feature.



GAS OUTDOES ITS RIVALS TOO.

As the standard engine, the free-breathing 6.2L V8 helps Super Duty® achieve up to 15% better fuel economy than the previous generation's base engine, making it the best in its class.¹ This state-of-the-art Ford-built powerhouse also generates best-in-class 385 hp and 405 lb.-ft. of torque.² Rest assured, it's ready for work. The Ford powertrain team designed, engineered, built and torture-tested this E85-capable engine themselves.



Produces significant low-rpm torque. The stiff SOHC valvetrain with roller-rocker shafts also enables an intake- and exhaust-port layout that optimizes airflow.

Provides extreme durability. The engine block features reliable cast-iron construction with 4-bolt main bearing caps including 2 additional cross bolts.

Stays cool under pressure. The underside of the cast-aluminum pistons are sprayed by oil from the piston-cooling jets to keep them cool under extreme operating conditions.



Standard TorqShift® 6-Speed SelectShift Automatic™ This rugged transmission is also designed, engineered and built by the Ford powertrain team. Its torque converter includes low-speed lockup capability (down to 900 rpm), which enables the engine to run efficiently at lower rpm. The high-strength sinter-metal carrier, with its patented Ford rocker one-way clutch, easily handles the extreme low-end torque of the diesel engine and the high speeds of the gas engine. Plus, a high-capacity, high-efficiency fluid filter extends your fluid- and filter-change intervals up to 150,000 miles.

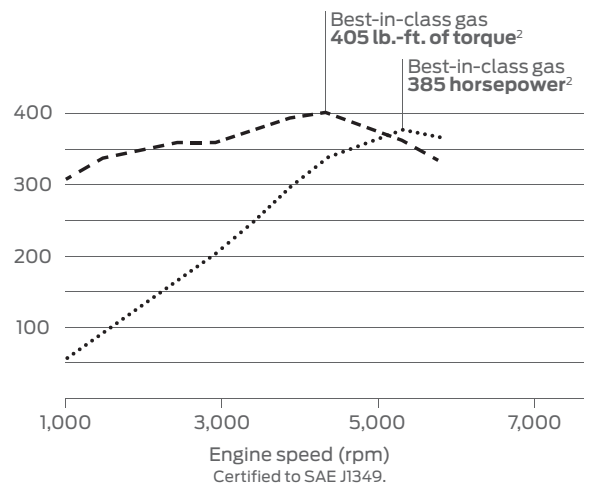

F-250 XLT SuperCab. Vermillion Red. Available equipment.

¹Based on Ford drive-cycle tests of comparably equipped 2011 Ford and 2010/2011 competitive models.

²405 lb.-ft. of torque and 385 hp, 10,000 lbs. GVWR and under. 397 lb.-ft. of torque and 316 hp, 10,000 lbs. GVWR and over.





Best-in-Class Max. Towing
17,500 LBS.
 Conventional
24,500 LBS.
 5th-Wheel

MASTERS THE HEAVIEST LOADS.

Super Duty® reigns supreme with best-in-class towing capabilities,¹ class-exclusive features and available systems like trailer sway control to help give you ultimate towing confidence. With the diesel powertrain, integrated engine-exhaust braking helps improve your control with less wear and tear on the brakes and transmission. It's the kind of functionality you'll really appreciate when you're hauling a heavy load or towing a trailer, and especially when you're descending steep grades.

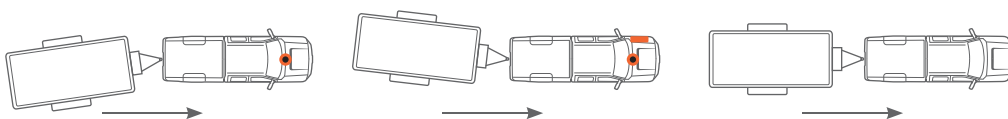

Helps you keep it in line. Our standard trailer sway control² uses a yaw motion sensor to monitor the motions of your truck and detect trailer sway. It can automatically react when sway is detected by selectively braking to help you maintain control of both the truck and the trailer. Super Duty is the only truck in its class with this system standard on both SRW and DRW models.

F-350 XLT Crew Cab DRW 4x4. Ingot Silver. F-450 LARIAT Crew Cab DRW 4x4. Black. Available equipment shown on each.

¹When properly equipped. ²Remember that even advanced technology cannot overcome the laws of physics. It's always possible to lose control of a vehicle due to inappropriate driver input for the conditions.



2012 SUPER DUTY® ford.com



HITS THE GROUND TOWING.

Your new Super Duty® can be ready for heavy-duty towing the moment you take delivery. Our factory-installed 5th-Wheel/Gooseneck Trailer Tow Prep Package¹ works with factory-installed Ford Custom Accessory 5th-Wheel and Gooseneck Hitch Kits² by Reese® (Gooseneck shown) to get you towing in no time. Plus, our equipment gives you the strength of an under-the-bed-frame crossmember (shown) and the utility of a flat cargo bed floor. PowerScope™ trailer tow mirrors¹ (shown) and our SelectShift Automatic™ transmission with its progressive range select and full manual modes are just a few of the invaluable towing tools you'll only find on Super Duty.



Prompts to check your setup. The LCD productivity screen¹ offers you a pre-towing checklist. It can also store settings and information on different trailers that you tow.



Helps you line it up. With the rear view camera¹ you just shift into Reverse and a full-color image of what's behind the vehicle is displayed in your rearview mirror or on the Navigation System's^{1,3} large screen (shown).



Makes connecting easy. Plug in your trailer wiring while standing upright with our class-exclusive in-bed 7-pin connector, part of the 5th-Wheel/Gooseneck Trailer Tow Prep Package¹.

F-450 KING RANCH® Crew Cab. Autumn Red/Pale Adobe two-tone. Available equipment.

¹Available feature. ²5th-Wheel Hitch available with 8' box only. See your Ford Dealer for complete details. ³Coming Fall 2011.



2012 SUPER DUTY® ford.com



KING RANCH WEARS ITS HERITAGE PROUDLY.

Super Duty® KING RANCH® conveys unparalleled luxury. Crafted with the same commitment to quality as the coveted saddles of the historic King Ranch Saddle Shop in Texas, its unique Chaparral leather trim weathers just as distinctively. Heated and cooled seats provide year-round comfort for you and your front passenger. Illuminated side steps guide your feet. And the KING RANCH “Running W” graces everything from the seat backs to the floor mats and even the wheels!

KING RANCH Crew Cab. Chaparral leather trim. Black environment. Available equipment.

¹Available 20" chrome-clad aluminum wheels shown.



2012 SUPER DUTY® ford.com



HANDS CONTROL THE WHEEL. VOICE CONTROLS THE REST.

Stay connected to calls, music and more with SYNC.

No more searching for your phone. No device on your ear. Connect to your world with voice-activated Ford SYNC.¹ Once paired, SYNC recognizes your phone and automatically transfers your contacts to support voice calling. It also plays music from your phone, MP3, USB or iPod.[®] Just touch a button on the steering wheel and say things like "Call Kevin," or "Play genre: Country." New AppLink¹ lets smartphone users control Pandora[®] internet radio (shown) and Stitcher SmartRadio[™] by voice too. SYNC also offers 911 Assist,[™] and with an activated SYNC Services account you get business searches,¹ turn-by-turn driving directions,¹ custom traffic alerts¹ and more. Personalize your experience at SyncMyRide.com.

Full-color, voice-activated travel guide with SiriusXM.

The Navigation System^{2,3} includes a 6-month trial subscription to SiriusXM Satellite Radio, Traffic and Travel Link⁴ to bring you over 130 channels of unique content, plus live infotainment services. Get continuously updated traffic information, plus check local fuel prices, weather reports, movie listings, sports scores and more. The vibrant 6.5" LCD touch screen features interactive maps you can zoom and scroll. Of course, it also responds to voice commands for hands-free control. Play DVDs while Super Duty[®] is in Park and store nearly 10 gigs of your digital music.

LARIAT Crew Cab 4x4. Adobe leather trim. Available equipment.

¹Available feature. Requires compatible mobile device. Driving while distracted can result in loss of vehicle control. Only use mobile phones and other devices, even with voice commands, when it is safe to do so. Traffic alerts and turn-by-turn directions available in select markets. Text message and data rates may apply. ²Available feature. ³Coming Fall 2011. ⁴SiriusXM Satellite Radio, Traffic and Travel Link subscriptions sold separately or as a package after trial expires. SiriusXM Traffic and Travel Link service available in select markets. Subscriptions are governed by SiriusXM Customer Agreement; see www.siriusxm.com.



2012 SUPER DUTY[®] ford.com



XLT MAKES A BIG IMPRESSION.

Super Duty® XLT definitely commands attention with its bold chrome bar-style grille and chrome bumpers. For even more shine, add the XLT Premium Package¹ (shown) with its numerous chrome accents including 6" angular step bars and new 18" chrome-clad aluminum wheels.² Every XLT also gets manually telescoping trailer tow mirrors with integrated spotters and heated glass. Inside, you'll find a 40/20/40 split front seat with lockable under-seat storage in the center section for added versatility.



F-250 XLT SuperCab 4x4. XLT Premium Package. Black. Available equipment.

¹Available feature. ²SRW models only.



2012 SUPER DUTY® ford.com

OUT-HAULS THEM ALL.

It's simple. Super Duty® fully supports your work ethic with the best max. payload capability in the class! Plus, it offers all the right tools to make loading, accessing and managing your payload as easy as possible. Like the torsion spring in our standard tailgate assist feature that minimizes the effort required to open and close the tailgate. It's one of the subtle details that make a big difference when you're working hard all day, every day, just like Super Duty.

Gives you a leg up. Just open the tailgate, drop the skid-resistant step down and grab the flip-up bar for easy access to the bed with our class-exclusive tailgate step² (shown).



Best-in-Class Max. Payload
7,110 LBS. |

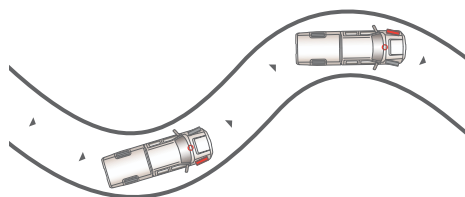

Masters challenging moments. Our exclusive AdvanceTrac® with RSC® (Roll Stability Control™) is the only electronic stability control system in the class that utilizes 2 gyroscopic sensors to help keep all 4 wheels firmly planted.³ It automatically helps avoid skidding and fishtailing, and is particularly beneficial in inclement weather.



Shields your investment. Go for the ToughBed® factory-installed spray-in bedliner² and we'll apply an industrial-grade synthetic lining directly to your bed for durable, long-lasting protection. Shown with Cable Lock by Master Lock.⁴

F-250 XL Regular Cab 4x2. Oxford White. Available equipment.

¹When properly equipped. F-350 DRW Regular Cab 4x2. ²Available feature. ³SRW models only. Engine-only traction control on DRW models. Remember that even advanced technology cannot overcome the laws of physics. It's always possible to lose control of a vehicle due to inappropriate driver input for the conditions. ⁴Ford Licensed Accessory. See your dealer for limited warranty details.



2012 SUPER DUTY® ford.com



CONQUERS MOST ANY TERRAIN.

Soon you'll be conquering it too. Our class-exclusive Hill Descent Control™¹ helps Super Duty® increase your off-road confidence by maintaining the truck's speed on steep declines, so you can concentrate on maneuvering. A durable coil-spring front suspension is part of the heavy-duty, independent Twin-I-Beam setup on 4x2s and a rugged twin-coil monobeam setup on 4x4s. With XL and XLT 4x4s, you get a solid front axle and manual locking hubs for excellent articulation and reliability. LARIAT and KING RANCH® 4x4s feature electronic shift-on-the-fly operation, giving you the ability to change your drive setting with the convenient turn of a dial on the instrument panel.



Tracks the action. You can monitor pitch angle, bank angle and wheel direction with our class-exclusive off-road display in the LCD productivity screen.²



Maximizes your grip. Our electronic-locking rear differential² uses a true mechanical dog-clutch mechanism to lock the rear axle shafts together so they turn at the same speed.

F-250 XLT SuperCab 4x4. Dark Blue Pearl. Available equipment.

¹SRW models with optional FX4 Off-Road Package only. ²Available feature.



2012 SUPER DUTY® ford.com



PROVEN WORKHORSES. LEGENDARY BLOODLINE.

It's an indisputable fact. There are more F-Series trucks on the road with 250,000+ miles than any other brand!¹ So you can rest assured every Super Duty[®] is built on a solid foundation – one engineered to get the job done, even under the most challenging conditions.

F-450

BEST MAXIMUM CAPABILITIES²

5th-Wheel Towing: 24,500 lbs.

Conventional Towing: 17,500 lbs.

Payload: 5,260 lbs.

GCWR: 33,000 lbs.

GVWR: 13,300 lbs.

Front GAWR: 6,000 lbs.

EQUIPMENT CONFIGURATIONS

Engine: 6.7L Power Stroke[®] V8 Only

Drivelines: 4x4 ■ Dual Rear Wheel Only

Body: Crew Cab ■ 8' Box Only

Trim Series: XL, XLT, LARIAT, KING RANCH[®]

F-350

BEST MAXIMUM CAPABILITIES²

5th-Wheel Towing: 22,700 lbs.

Conventional Towing: 17,500 lbs.

Payload: 7,110 lbs.

GCWR: 30,000 lbs.

GVWR: 13,300 lbs.

Front GAWR: 5,250 lbs. (4x2); 6,000 lbs. (4x4)

EQUIPMENT CONFIGURATIONS

Engines: 6.2L Gas V8, 6.7L Power Stroke V8

Drivelines: 4x2 or 4x4 ■ Single Rear Wheel or Dual Rear Wheel

Bodies: Regular Cab, SuperCab, Crew Cab ■ 6¾' or 8' Box

Trim Series: XL, XLT, LARIAT, KING RANCH

F-250

BEST MAXIMUM CAPABILITIES²

5th-Wheel Towing: 16,700 lbs.

Conventional Towing: 14,000 lbs.

Payload: 4,290 lbs.

GCWR: 23,500 lbs.

GVWR: 10,000 lbs.

Front GAWR: 5,250 lbs. (4x2); 6,000 lbs. (4x4)

EQUIPMENT CONFIGURATIONS

Engines: 6.2L Gas V8, 6.7L Power Stroke V8

Drivelines: 4x2 or 4x4 ■ Single Rear Wheel Only

Bodies: Regular Cab, SuperCab, Crew Cab ■ 6¾' or 8' Box

Trim Series: XL, XLT, LARIAT, KING RANCH

F-450 LARIAT Crew Cab 4x4. White Platinum Tri-coat/Pale Adobe two-tone. F-350 XLT SuperCab 4x4. Black. F-250 XL Regular Cab 4x2. Ingot Silver. Available or aftermarket equipment shown on each.

¹Based on vehicle registration data and latest odometer readings available to R. L. Polk & Co. for 1992 and newer model year full-size pickups still on the road in the U.S. as of 1/1/10. ²When properly equipped.



2012 SUPER DUTY[®] ford.com

LOTS OF WAYS TO MAKE IT YOURS.

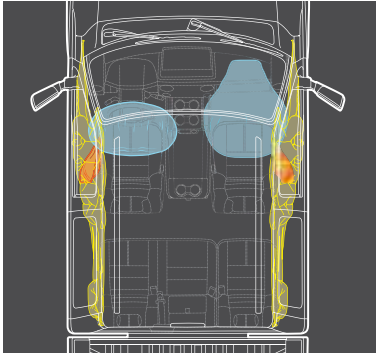

Take comfort in serious safety standards like the driver and right-front-passenger front airbags, front-seat side airbags, and our Safety Canopy® System with its rollover sensor and side-curtain airbags. Add options to help power your electronics, extend your cargo-carrying capabilities, stow your valuables securely out of sight and much more. Build the Super Duty® you want, just the way you want it.

6 airbags standard

Mini-console with front bucket seats¹

110-volt power outlet¹

Stowable bed extender¹

Crew Cab with lockable rear under-seat storage¹ and flow-through center console¹

¹Available feature.





F-250 XL Crew Cab in Oxford White customized with 5" black step bars, fog lamps, smoked side window deflectors, flat splash guards, commercial-grade tool/cargo box by Delta^{®1} and Ford Commercial Graphics by Original Wraps[™] Inc.¹

5th-wheel hitch kit

All-weather floor mats

Remote start systems

Dual head restraint DVD by INVISION^{™1}

Appearance

Chrome exhaust tip

Bed Products

Bed extender and tailgate liners

Retractable stake pocket tie-downs¹

Bed mats and sport liners¹

Tonneau covers¹

Electronics

Vehicle security systems

Parking assist systems¹

Exterior

Gooseneck hitch kit Contractor racks and carriers¹

Retractable rear steps¹

Sportz[®] truck tents¹

Trailer towing accessories

Wheel lock kit

Stainless steel wheel covers¹

Interior

Cargo organizers and protectors

Ash cup/coin holder

Leather-trimmed interior seating¹

Protective seat covers¹



¹Ford Licensed Accessory.

SUPER DUTY® Standard Features



Mechanical

97,500-mile tune-up interval ¹ (gas engines)
Battery saver
Conventional spare tire/wheel/jack with underframe carrier (crank-down type)
Engine-only traction control (EOTC) (DRW only)
Fail-Safe Engine Cooling System (gas engines)
Fuel tank – 26-gallon capacity (F-250/F-350 137," 142" and 156" WB with diesel engine)
Fuel tank – 35-gallon capacity (gas engine only)
Fuel tank – 37.5-gallon capacity (F-250/F-350 158" and 172" WB with diesel engine, and F-450)
Power steering
Quick-release tailgate with tailgate assist
Stabilizer bar – Front
Stabilizer bar – Rear (DRW only)
Stainless steel exhaust system (major components)
Stationary elevated idle control (SEIC) ²
Steering damper
Styleside box
Tire Pressure Monitoring System (SRW only; excludes spare)
Trailer hitch receiver – 12.5K (2") Built Ford Tough® (SRW)
Trailer hitch receiver – 14K (2.5") Built Ford Tough (SRW diesel with 156," 158" and 172" WB only)
Trailer hitch receiver – 15K (2.5") Built Ford Tough (F-350 DRW 137" and 158" WB only)
Trailer hitch receiver – 17.5K (2.5") Built Ford Tough (F-350 DRW 172" WB and F-450 only)
Trailer hitch receiver – 2" sleeve reducer (vehicles with 2.5" receiver)
Trailer sway control
Interior
Air conditioning
Assist and ride handles
Coat hooks – 1 (Regular Cab); 2 in rear of cab (SuperCab and Crew Cab)
Dome light (front and rear with Crew Cab)
Flip-open rear quarter windows (SuperCab)
MyKey®
Overhead console with garage door opener storage and sunglasses storage (SuperCab and Crew Cab)
Powerpoints – 12-volt, 2 on instrument panel
Tilt/telescoping steering column

Exterior

7-/4-pin trailer tow connector and trailer brake wiring kit (in-cab; no controller)
Cargo box rail and tailgate top moldings
Cargo box stake pockets
Cargo tie-down hooks (4 in 6¾' box; 6 in 8' box)
Dual-beam jewel-effect headlamps
Front and rear step bumpers
Integrated cargo box lamp with center high-mounted stop lamp
Intelligent 3-blink turn signal
Partitionable and stackable cargo box
Roof clearance lamps (DRW)
Solar-tinted glass
Tow hooks (2 in front)
Underhood service lamp
Windshield wipers – Intermittent

Safety & Security

Airbags ³ – Driver and right-front-passenger front
Airbags ³ – Front-seat side
Airbags ³ – Safety Canopy® System with roll-fold side-curtain airbags
AdvanceTrac® with RSC® (Roll Stability Control™) (SRW only)
Belt-Minder® front safety belt reminder
Brake/shift interlock
Brakes – 4-wheel power disc with Anti-Lock Brake System (ABS)
Child-safety-seat top tether anchors (Regular Cab front passenger and all rear-seat positions)
Fuel pump inertia shutoff switch
Headlamps-on, key-in-ignition and door ajar alert chimes
Height-adjustable safety belts at front-outboard positions
Locking tailgate
Passenger airbag deactivation switch (Regular Cab, SuperCab)
Safety belt energy-management retractors at front-outboard positions
SecuriLock® Passive Anti-Theft System
Side-intrusion door beams
SOS Post-Crash Alert System™
Spare tire/wheel lock

XL

Includes all standard features, plus:

Mechanical

6.2L SOHC 2-valve Gas V8 Flex Fuel E85-capable engine (n/a on F-450)
6.7L Power Stroke® V8 Turbo Diesel B20-capable engine (standard on F-450)
TorqShift® Heavy-Duty 6-speed SelectShift Automatic™ transmission
Integrated trailer brake controller (DRW)
Manual 4-Wheel-Drive System with manual locking hubs (4x4 models only)
17" argent-painted steel wheels (F-250/F-350)
17" polished forged-aluminum wheels (F-450)
LT245/75R17 all-season BSW tires

Seating

40/20/40 split HD vinyl front seat with armrest, cupholders and storage
60/40 split flip-up rear seat (SuperCab only)
60/40 split flip-up/fold-down rear bench seat with outboard and center head restraints (Crew Cab only)
Lumbar support for driver's seat

Interior

AM/FM stereo with digital clock and 2 speakers
Climate controls – Manual
Door locks – Manual
Flooring – Black vinyl
Message center – Multifunction plus trip computer includes 3-button steering wheel switch, odometer, trip odometer, engine oil monitor, engine-hour meter, engine-idle meter (6.2L Gas only), distance to empty, average fuel economy, warning messages, system check, language selection and Ice Blue™ Lighting
Mirror – Manual day/night rearview
Steering wheel – Black urethane
Visors with passenger mirror
Windows – Manual

Exterior

Black box top and tailgate moldings
Bumpers – Black-painted with grained top cover
Cab steps – 6" angular black molded (DRW only)
Door handles – Black
Grille – Black bar-style
Mirrors – Manually telescoping trailer tow with 2-way fold and manual glass

¹Under normal driving conditions with routine fluid and filter changes. ²Final-stage manufacturer must supply control switches. ³Always wear your safety belt and follow airbag warning label instructions.

Comparisons based on 2011 competitive models (class is Full-Size Pickups over 8,500 lbs. GVWR), publicly available information and Ford certification data at time of release. Some features discussed may be optional. Vehicles throughout this PDF are shown with optional and aftermarket equipment. Features shown may be offered only in combination with other options or subject to additional ordering requirements or limitations. Dimensions and capacity ratings shown may vary due to optional features and/or production variability. Following release of the PDF, certain changes in standard equipment, options and the like, or product delays may have occurred which would not be included in these pages. Your Ford Dealer is the best source for up-to-date information. Ford Division reserves the right to change product specifications at any time without incurring obligations. Body manufacturers are responsible for compliance certification of the completed vehicle. The Ford New Vehicle Limited Warranty and any government certification made by Ford shall cover only the vehicle as manufactured by Ford and shall not extend to any addition, modification or change of or to the vehicle by the Ford Authorized Pool Account.



SUPER DUTY® Standard Features



XLT

Includes all XL features, plus:

Mechanical

Integrated trailer brake controller (SRW)

17" 5-spoke cast-aluminum wheels (SRW)

Seating

4-way adjustable driver and right-front-passenger head restraints

40/20/40 split front seat with center under-seat lockable storage with 12-volt powerpoint and center armrest with cupholders and storage

60/40 split flip-up/fold-down rear bench seat with bag hooks, dual integrated cupholders and tray, outboard head restraints, center head restraint and lockable under-seat partitioned storage with 12-volt powerpoint (Crew Cab only)

Interior

AM/FM stereo/single-CD player with MP3 capability, digital clock, 4 speakers and auxiliary audio input jack

Accessory delay for power features

Cruise control

Door locks – Power

Flooring – Color-coordinated carpet

Flooring – Color-coordinated carpeted floor mats

Windows – Power with one-touch-down driver's side window feature

Visors with covered driver and passenger mirrors

Exterior

Bumpers – Chrome with grained top cover

Grille – Chrome bar-style

Mirrors – Manually telescoping trailer tow with 2-way fold, power/heated glass, heated manual spotter mirrors, and integrated clearance lamps and turn signals

Perimeter anti-theft alarm

Privacy glass (rear doors and rear window)

Remote Keyless Entry System with 2 integrated keyhead transmitter remotes



LARIAT

Includes all XLT features, plus:

Mechanical

Electronic shift-on-the-fly (ESOF) 4-Wheel-Drive System with auto/manual locking hubs (4x4 models only)

Reverse Sensing System

17" polished forged-aluminum wheels (F-350 DRW)

18" bright-machined cast-aluminum wheels (SRW)

LT275/65R18 all-season BSW tires (SRW)

Seating

40/console/40 leather-trimmed front bucket seats and flow-through center console with lockable storage, two 12-volt powerpoints and a 110-volt power outlet

Power 10-way driver and front-passenger seats

Interior

Premium Sound System includes AM/FM stereo/single-CD player with MP3 capability, digital clock and 8 speakers with subwoofer

Ford SYNC® voice-activated, in-vehicle connectivity system

SiriusXM Satellite Radio with 6-month trial subscription

Dual-zone electronic automatic temperature control

Message center – Driver-configurable enhanced information center with LCD productivity screen includes gauge setup, compass, trip computer, fuel economy and towing/off-road applications, SelectShift controls, Ice Blue Lighting, halo lighting, daytime illumination and 5-button steering wheel-mounted switch

Mirror – Auto-dimming rearview

Power-adjustable pedals

Steering wheel – Color-coordinated leather-wrapped with secondary audio and 5-button message center controls

Visors with illuminated driver and passenger mirrors

Woodgrain-style instrument panel accents

Exterior

Autolamp with rainlamp feature

Cab steps – 5" chrome tubular (DRW)

Door handles – Body-color

Fog lamps

Mirrors – PowerScope™ power-telescoping/-folding trailer tow with power/heated glass, heated manual spotter mirrors, and integrated clearance lamps and turn signal indicators

Rear window – Power-sliding with privacy glass and defrost

SecuriCode™ keyless entry keypad



KING RANCH®

Includes all LARIAT features, plus:

Seating

Chaparral leather-trimmed front seats with flow-through center console

Easy entry/exit driver's seat memory feature

Heated/cooled driver and front-passenger seats

Interior

Flooring – Color-coordinated carpeted floor mats with King Ranch logo

Memory Group includes memory feature on power trailer tow mirrors, power 10-way driver's seat, and adjustable pedals

Rear view camera

Remote Start System

Steering wheel – Chaparral leather-wrapped with secondary audio and 5-button message center controls

Unique woodgrain-style instrument panel accents

Universal garage door opener

Exterior

Accent-color box top and tailgate moldings

Accent-color wheel-lip moldings (SRW)

Body-color bodyside moldings (SRW)

Bumpers – Accent-color monochromatic

Cab steps – Illuminated accent-color with bright insert

Grille – Body-color surround with chrome insert

Mirrors – PowerScope power-telescoping/-folding trailer tow with memory, power/heated glass, heated manual spotter mirrors, integrated clearance lamps and turn signal indicators with body-color mirror caps

Two-tone lower-accent paint





XL

Mechanical

6.7L Power Stroke® V8 Turbo Diesel B20-capable engine (standard on F-450)
Electronic shift-on-the-fly (ESOF) 4-Wheel-Drive System with auto/manual locking hubs (4x4 models only)
5th-wheel hitch kit (requires 8' box) ¹
Gooseneck hitch kit ¹
Alternator – Single, extra-heavy-duty 200-amp (diesel engine only)
Alternators – Dual, 357-amp total (diesel engine only)
Engine block heater (standard in 15 cold-weather states)
Integrated trailer brake controller (standard on F-350 DRW/F-450)
Operator commanded exhaust filter regeneration (diesel engine only)
Power takeoff (PTO) provision allows transmission-mounted live-drive and stationary modes (diesel engine only)
Rear axle – Electronic-locking (F-250/F-350 SRW only)
Rear axle – Limited-slip (F-350 DRW only; standard on F-450)
17" 5-spoke cast-aluminum wheels – 4 (F-250/F-350 SRW)
17" polished forged-aluminum wheels – 4 (F-350 DRW)
18" argent-painted steel wheels – 4 (F-350 SRW)
Stainless steel wheel covers (requires 17" argent-painted steel wheels) ²
LT245/75R17 all-terrain BSW tires – 5
LT265/70R17 all-terrain OWL tires – 4 (F-250/F-350 SRW)
LT275/65R18 all-season BSW tires – 5 (F-350 SRW)
LT275/70R18 all-terrain BSW tires – 4 (F-350 SRW)

Seating

40/mini-console/40 front bucket seats (HD vinyl or cloth)

Interior

Ford SYNC® voice-activated, in-vehicle connectivity system (requires XL Value Package and steering wheel-mounted audio controls)
Rapid-heat supplemental cab heater (requires diesel engine and alternator upgrade)
Remote Start System (requires Power Equipment Group)
Steering wheel-mounted audio controls (requires SYNC)
Upfitter switches located on instrument panel (4)

Exterior

Bed mat (restrictions apply)
Cab steps – 6" angular black molded (standard on DRW)
Exterior backup alarm ²
Pickup box delete (F-250/F-350 only; requires 8' box; n/a with 20" wheels or FX4 Off-Road Package)
Roof clearance lamps (standard on DRW)
Soft roll-up tonneau cover ²
Splash guards/mud flaps (front and rear on SRW; rear only on DRW)
Tailgate step includes step, tailgate assist and grab bar
ToughBed® spray-in bedliner includes tailgate guard and black bed bolts

Ford Work Solutions™

Cable Lock by Master Lock® ²
Crew Chief™ powered by Telogis® – Fleet tracking system ²

Packages

XL Value Package includes AM/FM stereo/single-CD player with MP3 capability, digital clock, 4 speakers, cruise control, 17" argent-painted steel wheels with bright center cap (SRW only), and chrome bumpers

5th-Wheel/Gooseneck Trailer Tow Prep Package includes 1 under-bed-frame crossmember, 5 pickup bed 5th-wheel/gooseneck attachment points and close-out plugs, and an integrated 7-pin connector on the driver's side pickup bed wall

9,900-lb. GVWR Package (F-250)

10,000-lb. GVWR Package (F-350 SRW)

Camper Package includes front springs upgrade (unless maximum springs have been computer-selected as included equipment), rear stabilizer bar (SRW), slide-in-camper certification and auxiliary rear springs on F-250 (restrictions apply)

CNG/LPG Gaseous Engine Prep Package includes hardened engine intake valves and valve seats and bi-fuel manifold (F-250/F-350 with 6.2L gas engine only)

FX4 Off-Road Package includes transfer case and fuel tank skid plates, Hill Descent Control™ (SRW only), Rancho® shocks and FX4 Off-Road box decals (restrictions apply)

Heavy-Service Front Suspension Package includes front springs upgrade (unless maximum springs have been computer-selected as included equipment; restrictions apply)

Power Equipment Group includes power door locks and front windows (plus rear on Crew Cab) with one-touch-down driver's side window feature; manually telescoping trailer tow mirrors with 2-way fold, power/heated glass, heated manual spotter mirrors, and integrated clearance lamps and turn signals; accessory delay; Remote Keyless Entry System with 2 integrated keypad transmitter remotes; and perimeter anti-theft alarm

Snow Plow Prep Package includes computer-selected springs for snow plow application and extra-heavy-duty alternator with diesel engine only (4x4 only; restrictions apply)

¹Requires 5th-Wheel/Gooseneck Trailer Tow Prep Package. See your dealer for details. ²Ford Licensed Accessory. See your dealer for limited warranty details.





XLT

Mechanical

6.7L Power Stroke® V8 Turbo Diesel B20-capable engine (standard on F-450)
Electronic shift-on-the-fly (ESOF) 4-Wheel-Drive System with auto/manual locking hubs (4x4 models only)
5th-wheel hitch kit (requires 8' box) ¹
Gooseneck hitch kit ¹
Alternator – Single, extra-heavy-duty 200-amp (diesel engine only)
Alternators – Dual, 357-amp total (diesel engine only)
Engine block heater (standard in 15 cold-weather states)
Operator commanded exhaust filter regeneration (diesel engine only)
Power takeoff (PTO) provision allows transmission-mounted live-drive and stationary modes (diesel engine only)
Rear axle – Electronic-locking (F-250/F-350 SRW only)
Rear axle – Limited-slip (F-350 DRW; standard on F-450)
Reverse Sensing System (n/a with pickup box delete)
17" polished forged-aluminum wheels – 4 (F-350 DRW)
18" cast-aluminum wheels – 4 (F-250/F-350 SRW)
Stainless steel wheel covers (require 17" argent-painted steel DRW wheels) ²
LT245/75R17 all-terrain BSW tires – 5 (F-350 DRW/F-450)
LT245/75R17 all-terrain OWL tires – 4 (F-350 DRW/F-450)
LT265/70R17 all-terrain OWL tires – 4 (F-250/F-350 SRW)
LT275/65R18 all-season BSW tires – 5 (F-250/F-350 SRW)
LT275/70R18 all-terrain BSW tires – 4 (F-250/F-350 SRW 4x4)
LT275/70R18 all-terrain OWL tires – 4 (F-250/F-350 SRW 4x4)

Seating

40/console/40 front bucket seats with power 6-way driver's seat and flow-through console with lockable storage, two 12-volt powerpoints and a 110-volt power outlet (SuperCab and Crew Cab only)

Interior

Ford SYNC® voice-activated, in-vehicle connectivity system (requires XLT Interior Package and steering wheel-mounted audio controls)
SiriusXM Satellite Radio with 6-month trial subscription
Flooring – Black all-weather floor mats (deletes carpeted floor mats)
Rapid-heat supplemental cab heater (requires diesel engine and alternator upgrade)
Rear view camera (requires XLT Interior Package or XLT Premium Package)
Remote Start System
Steering wheel-mounted audio controls (requires SYNC)
Upfitter switches located on instrument panel (4)

Exterior

Bed mat (restrictions apply)
Body-color bodyside moldings (SRW SuperCab and Crew Cab only)
Cab steps – 6" angular black molded (standard on DRW)
Cab steps – 5" chrome tubular (SuperCab and Crew Cab only)
Exterior backup alarm ²
Mirrors – PowerScope™ power-telescoping/-folding trailer tow with power/heated glass, heated manual spotter mirrors, and integrated clearance lamps and turn signals
Pickup box delete (F-250/F-350 only; requires 8' box; n/a with 20" wheels or FX4 Off-Road Package)
Rear window – Manual-sliding with privacy glass (Regular Cab only)
Rear window – Power-sliding with privacy glass and defrost (SuperCab and Crew Cab only)
Roof clearance lamps (standard on DRW)
Soft roll-up tonneau cover ²
Splash guards/mud flaps (front and rear on SRW; rear only on DRW)
Stowable bed extender (F-250/F-350 SRW only)
Tailgate step includes step, tailgate assist and grab bar
ToughBed® spray-in bedliner includes tailgate guard and black bed bolts

Ford Work Solutions™

Cable Lock by Master Lock® ²
Crew Chief™ powered by Telogis® – Fleet tracking system ²

Packages

XLT Interior Package includes 6-way power driver's seat, power-adjustable pedals, autolamp/rainlamp, autolock/unlock and SecuriCode™ keyless entry keypad
XLT Value Package includes 6-way power driver's seat, power-adjustable pedals, autolamp/rainlamp, autolock/unlock, SecuriCode keyless entry keypad, fog lamps, SYNC and steering wheel-mounted audio controls
XLT Premium Package includes XLT Interior Package, bright metallic exhaust tip, chrome tow hooks, unique chrome mirror caps, chrome cargo tie-down hooks, 6" chrome angular step bars, 18" chrome-clad aluminum wheels with LT275/65R18 all-season BSW tires (on SRW only), SYNC, LCD productivity screen, auto-dimming rearview mirror, compass, fog lamps and steering wheel-mounted audio controls (requires PowerScope mirrors; SuperCab and Crew Cab only)

5th-Wheel/Gooseneck Trailer Tow Prep Package includes 1 under-bed-frame crossmember, 5 pickup bed 5th-wheel/gooseneck attachment points and close-out plugs, and an integrated 7-pin connector on the driver's side pickup bed wall (n/a with stowable bed extender)

9,900-lb. GVWR Package (F-250)

10,000-lb. GVWR Package (F-350 SRW)

Camper Package includes front springs upgrade (unless maximum springs have been computer-selected as included equipment), rear stabilizer bar (SRW), slide-in-camper certification and auxiliary rear springs on F-250 (restrictions apply)

CNG/LPG Gaseous Engine Prep Package includes hardened engine intake valves and valve seats and bi-fuel manifold (F-250/F-350 with 6.2L gas engine only)

FX4 Off-Road Package includes transfer case and fuel tank skid plates, Hill Descent Control™ (SRW only), Rancho® shocks and FX4 Off-Road box decals (restrictions apply)

Heavy-Service Front-Suspension Package includes front springs upgrade (unless maximum springs have been computer-selected as included equipment; restrictions apply)

Snow Plow Prep Package includes computer-selected springs for snow plow application and extra-heavy-duty alternator with diesel engine only (4x4 only; restrictions apply)

¹Requires 5th-Wheel/Gooseneck Trailer Tow Prep Package. See your dealer for details.

²Ford Licensed Accessory. See your dealer for limited warranty details.





LARIAT

Mechanical

- 6.7L Power Stroke® V8 Turbo Diesel B20-capable engine (standard on F-450)

- 5th-wheel hitch kit (requires 8' box)¹

- Gooseneck hitch kit¹

- Alternator – Single, extra-heavy-duty 200-amp (diesel engine only)

- Alternators – Dual, 357-amp total (diesel engine only)

- Engine block heater (standard in 15 cold-weather states)

- Power takeoff (PTO) provision allows transmission-mounted live-drive and stationary modes (diesel engine only)

- Rear axle – Electronic-locking (F-250/F-350 SRW only)

- Rear axle – Limited-slip (F-350 DRW; standard on F-450)

- 20" premium cast-aluminum wheels – 4 (F-250/F-350 SRW 4x4 diesel engine only)

- 20" chrome-clad aluminum wheels – 4 (requires Chrome Package; F-250/F-350 SRW 4x4 diesel engine only)

- LT245/75R17 all-terrain BSW tires – 5 (F-350 DRW/F-450)

- LT245/75R17 all-terrain OWL tires – 4 (F-350 DRW/F-450)

- LT275/70R18 all-terrain BSW tires – 4 (F-250/F-350 SRW 4x4)

- LT275/70R18 all-terrain OWL tires – 4 (F-250/F-350 SRW 4x4)

- LT275/65R20 all-terrain OWL tires – 4 (F-250/F-350 SRW 4x4)

Seating

40/20/40 leather-trimmed split front seats, center under-seat lockable storage with 12-volt powerpoint, and center armrest with cupholders and storage

Interior

- Navigation System² with Premium Sound System includes HD Radio™ Technology, AM/FM stereo/single-CD player with MP3 capability, USB port, in-dash touch screen, voice-activated controls, SiriusXM Traffic and Travel Link capability, digital clock and 8 speakers with subwoofer (requires rear view camera)

- Flooring – Black all-weather floor mats (deletes carpeted floor mats)

- Rapid-heat supplemental cab heater (requires diesel engine and alternator upgrade)

- Rear view camera

- Remote Start System

- Upfitter switches located on instrument panel (4)

- Universal garage door opener

Exterior

- Bed mat (restrictions apply)

- Body-color bodyside moldings (SRW only)

- Cab steps – 5" chrome tubular (standard on DRW)

- Exterior backup alarm³

- Power-sliding moonroof (Crew Cab only)

- Roof clearance lamps (standard on DRW)

- Soft roll-up tonneau cover³

- Splash guards/mud flaps (front and rear on SRW; rear only on DRW)

- Stowable bed extender (F-250/F-350 SRW only)

- Tailgate step includes step, tailgate assist and grab bar

- ToughBed® spray-in bedliner includes tailgate guard and black bed bolts

- Two-tone lower-accent paint (includes accent-color wheel-lip moldings on SRW)

Ford Work Solutions™

- Cable Lock by Master Lock^{®3}

- Crew Chief™ powered by Telogis® – Fleet tracking system³

Packages

LARIAT Interior Package includes rear view camera, easy entry/exit memory power heated/cooled driver's seat, power heated/cooled front-passenger seat, memory power trailer tow mirrors, memory power-adjustable pedals, and Remote Start System

LARIAT Ultimate Package² includes easy entry/exit memory power heated/cooled driver's seat; power heated/cooled passenger seat; memory power trailer tow mirrors; memory power-adjustable pedals; moonroof; Navigation System; rear view camera; tailgate step; and Remote Start System (Crew Cab only; restrictions apply)

5th-Wheel/Gooseneck Trailer Tow Prep Package

includes 1 under-bed-frame crossmember, 5 pickup bed 5th-wheel/gooseneck attachment points and close-out plugs, and an integrated 7-pin connector on the driver's side pickup bed wall (n/a with stowable bed extender)

9,900-lb. GVWR Package (F-250)

10,000-lb. GVWR Package (F-350 SRW)

Camper Package includes front springs upgrade (unless maximum springs have been computer-selected as included equipment), rear stabilizer bar (SRW), slide-in-camper certification and auxiliary rear springs on F-250 (restrictions apply)

Chrome Package includes bright metallic exhaust tip, chrome tow hooks, unique chrome mirror caps, chrome cargo tie-down hooks, 6" chrome angular step bars and 18" chrome-clad aluminum wheels with LT275/65R18 all-season BSW tires (on SRW only) (requires PowerScope™ mirrors; SuperCab and Crew Cab only; other restrictions apply)

CNG/LPG Gaseous Engine Prep Package includes hardened engine intake valves and valve seats and bi-fuel manifold (F-250/F-350 with 6.2L gas engine only)

FX4 Off-Road Package includes transfer case and fuel tank skid plates, Hill Descent Control™ (SRW only), Rancho® shocks and FX4 Off-Road box decals (restrictions apply)

Heavy-Service Front Suspension Package includes front springs upgrade (unless maximum springs have been computer-selected as included equipment; restrictions apply)

Snow Plow Prep Package includes computer-selected springs for snow plow application and extra-heavy-duty alternator with diesel engine only (4x4 only; restrictions apply)

¹Requires 5th-Wheel/Gooseneck Trailer Tow Prep Package. See your dealer for details. ²Coming Fall 2011. ³Ford Licensed Accessory. See your dealer for limited warranty details.





KING RANCH®

Mechanical

- 6.7L Power Stroke® V8 Turbo Diesel B20-capable engine (standard on F-450)

- 5th-wheel hitch kit (requires 8' box)¹

- Gooseneck hitch kit¹

- Alternator – Single, extra-heavy-duty 200-amp (diesel engine only)

- Alternators – Dual, 357-amp total (diesel engine only)

- Engine block heater (standard in 15 cold-weather states)

- Power takeoff (PTO) provision allows transmission-mounted live-drive and stationary modes (diesel engine only)

- Rear axle – Electronic-locking (F-250/F-350 SRW only)

- Rear axle – Limited-slip (F-350 DRW; standard on F-450)

- 20" premium painted cast-aluminum wheels – 4 (F-250/F-350 SRW 4x4 diesel engine only)

- 20" chrome-clad aluminum wheels – 4 (requires Chrome Package; F-250/F-350 SRW 4x4 diesel engine only; SuperCab and Crew Cab only)

- LT275/70R18 all-terrain BSW tires – 4 (F-250/F-350 SRW 4x4)

- LT275/70R18 all-terrain OWL tires – 4 (F-250/F-350 SRW 4x4)

- LT275/65R20 all-terrain OWL tires – 4 (F-250/F-350 SRW 4x4)

Interior

- Navigation System² with Premium Sound System includes HD Radio™ Technology, AM/FM stereo/single-CD player with MP3 capability, USB port, in-dash touch screen, voice-activated controls, SiriusXM Traffic and Travel Link capability, digital clock and 8 speakers with subwoofer

- Rapid-heat supplemental cab heater (requires diesel engine and alternator upgrade)

- Upfitter switches located on instrument panel (4)

Exterior

- Bed mat (restrictions apply)

- Exterior backup alarm³

- Power-sliding moonroof

- Roof clearance lamps (standard on DRW)

- Soft roll-up tonneau cover³

- Splash guards/mud flaps (front and rear on SRW; rear only on DRW)

- Stowable bed extender (F-250/F-350 SRW only)

- Tailgate step includes step, tailgate assist and grab bar

- ToughBed® spray-in bedliner includes tailgate guard and black bed bolts

Ford Work Solutions™

- Cable Lock by Master Lock®³

- Crew Chief™ powered by Telogis® – Fleet tracking system³

Packages

KING RANCH with Chrome Package includes bright metallic exhaust tip, chrome tow hooks, unique chrome mirror caps, chrome cargo tie-down hooks, 6" chrome angular step bars, and 18" chrome-clad aluminum wheels with LT275/65R18 all-season BSW tires (on SRW only)

5th-Wheel/Gooseneck Trailer Tow Prep Package includes 1 under-bed-frame crossmember, 5 pickup bed 5th-wheel/gooseneck attachment points and close-out plugs, and an integrated 7-pin connector on the driver's side pickup bed wall (n/a with stowable bed extender)

9,900-lb. GVWR Package (F-250)

10,000-lb. GVWR Package (F-350 SRW)

Camper Package includes front springs upgrade (unless maximum springs have been computer-selected as included equipment), rear stabilizer bar (SRW), slide-in-camper certification and auxiliary rear springs on F-250 (restrictions apply)

CNG/LPG Gaseous Engine Prep Package includes hardened engine intake valves and valve seats and bi-fuel manifold (F-250/F-350 with 6.2L gas engine only)

FX4 Off-Road Package includes transfer case and fuel tank skid plates, Hill Descent Control™ (SRW only), Rancho® shocks and FX4 Off-Road box decals (restrictions apply)

Heavy-Service Front Suspension Package includes front springs upgrade (unless maximum springs have been computer-selected as included equipment; restrictions apply)

Snow Plow Prep Package includes computer-selected springs for snow plow application and extra-heavy-duty alternator with diesel engine only (4x4 only; restrictions apply)

¹Requires 5th-Wheel/Gooseneck Trailer Tow Prep Package. See your dealer for details. ²Coming Fall 2011. ³Ford Licensed Accessory. See your dealer for limited warranty details.



SUPER DUTY® Optional Features

XL/XLT



Argent-Painted Steel
17" Standard on F-250/F-350 SRW XL
18" Optional on F-350 SRW XL



17" Polished Forged-Aluminum (DRW)
Standard on F-450 DRW XL & XLT
Optional on F-350 DRW XL & XLT



17" Argent-Painted Steel
w/Bright Center Cap
Included on F-250/F-350 SRW XL
w/XL Value Package



17" 5-Spoke Cast-Aluminum
Optional on F-250/F-350 SRW XL
Standard on F-250/F-350 SRW XLT



17" Argent-Painted Steel (DRW)
Standard on F-350 DRW XL & XLT



18" Chrome-Clad Aluminum
Included on F-250/F-350 SRW XLT
w/XLT Premium Package



17" Argent-Painted Steel
w/Stainless Steel Covers
Optional on F-350 DRW XL & XLT



18" Cast-Aluminum
Optional on F-250/F-350 SRW XLT

LARIAT



17" Polished Forged-Aluminum (DRW)
Standard on F-350 DRW/F-450



18" Bright-Machined Cast-Aluminum
Standard on F-250/F-350 SRW



18" Chrome-Clad Aluminum
Included on F-250/F-350 SRW
w/Chrome Package



20" Premium Cast-Aluminum
Optional on F-250/F-350 SRW



20" Chrome-Clad Aluminum
Optional on F-250/F-350 SRW 4x4
w/Chrome Package

KING RANCH®



17" Polished Forged-Aluminum (DRW)
Included on F-350 DRW/F-450



18" Bright-Machined Cast-Aluminum
Included on F-250/F-350 SRW



18" Chrome-Clad Aluminum
Included on F-250/F-350 SRW
w/Chrome Package



20" Premium Painted Cast-Aluminum
Optional on F-250/F-350 SRW



20" Chrome-Clad Aluminum
Optional on F-250/F-350 SRW 4x4
w/Chrome Package



Regular Cab



SuperCab



Crew Cab

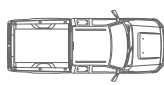

6 3/4' Box Size

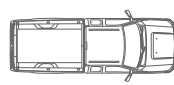

8' Box Size

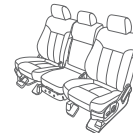

40/20/40
split front seat

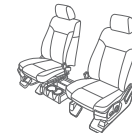

40/mini-console/40
front bucket seats



40/console/40
front bucket seats

XL	<input type="radio"/>	<input type="radio"/>	<input type="radio"/>	<input type="radio"/>	<input type="radio"/>	<input checked="" type="radio"/>	<input type="radio"/>	<input type="radio"/>
XLT	<input type="radio"/>	<input type="radio"/>	<input type="radio"/>	<input type="radio"/>	<input type="radio"/>	<input checked="" type="radio"/>	<input type="radio"/>	<input type="radio"/>
LARIAT	<input type="radio"/>	<input type="radio"/>	<input type="radio"/>	<input type="radio"/>	<input type="radio"/>	<input type="radio"/>	<input type="radio"/>	<input checked="" type="radio"/>
KING RANCH	<input type="radio"/>	<input type="radio"/>	<input type="radio"/>	<input type="radio"/>	<input type="radio"/>	<input type="radio"/>	<input type="radio"/>	<input checked="" type="radio"/>

● Standard ○ Optional



SUPER DUTY® Optional Features

XL/XLT



Exteriors	Interiors	
	XL	XLT
Oxford White	1, 2	2, 3
Ingot Silver Metallic	1, 2	2
Sterling Gray Metallic	1, 2	2
Pale Adobe Metallic (XLT only)	1, 2	3
Golden Bronze Metallic (XLT only)		3
Vermillion Red	1, 2	2, 3
Autumn Red Metallic ¹ (XLT only)		3
Dark Blue Pearl Metallic	1, 2	2
Forest Green Metallic	1, 2	2, 3
Black ²	1, 2	2, 3
Tuxedo Black Metallic ³	1, 2	2, 3

¹New for 2012. ²Limited availability. ³Late availability. Colors are representative only. See your dealer for actual paint/trim options.

LARIAT/KING RANCH®



Exteriors	Two-Tone	Interiors	
		LARIAT	KING RANCH
White Platinum Metallic Tri-coat ¹	■	1, 2	3, 4
Oxford White	■ ■	1, 2	3, 4
Ingot Silver Metallic	■	2	
Sterling Gray Metallic		2	
Pale Adobe Metallic		1, 2	
Golden Bronze Metallic	■	1, 2	3, 4
Vermillion Red		1, 2	
Autumn Red Metallic ²	■	1, 2	3, 4
Dark Blue Pearl Metallic	■	2	
Forest Green Metallic	■ ■	1, 2	3, 4
Black ³	■ ■	1, 2	3, 4
Tuxedo Black Metallic ⁴	■ ■	1, 2	3, 4

■ Pale Adobe Two-Tone Accent exterior standard on KING RANCH, optional on LARIAT
 ■ Sterling Gray Two-Tone Accent exterior optional on LARIAT with Black Leather interior only; not available on KING RANCH

¹Additional charge. ²New for 2012. ³Limited availability. ⁴Late availability. Colors are representative only. See your dealer for actual paint/trim options.



TECHNICAL SPECIFICATIONS

DIMENSIONS

	Regular Cab		SuperCab			Crew Cab		
	LWB 4x2/4x4	SWB 4x2/4x4	LWB 4x2/4x4	LWB 4x2/4x4	SWB 4x2/4x4	LWB 4x2/4x4	LWB 4x2/4x4	LWB 4x2/4x4
Exterior								
A. Height — F-250 SRW (w/o options)	76.6"/79.2"	77.0"/79.5"	76.9"/79.3"	77.4"/79.7"	77.3"/79.8"	76.5"/80.0"	76.9"/80.4"	76.9"/79.7"
A. Height — F-350 SRW (w/o options)	76.5"/80.0"	76.9"/80.4"	76.7"/80.2"	77.2"/80.8"	77.2"/80.8"	76.1"/79.5"	—	79.7"
A. Height — F-350 DRW (w/o options)	76.7"/79.5"	—	76.9"/79.7"	—	—	—	—	—
A. Height — F-450 DRW (w/o options)	—	—	—	—	—	—	—	—
B. Width — SRW (excl. mirrors)	79.9"	79.9"	79.9"	79.9"	79.9"	79.9"	79.9"	79.9"
B. Width — DRW (excl. mirrors)	96.0"	—	96.0"	—	—	96.0"	—	96.0"
B. Width — With mirrors	104.9"	104.9"	104.9"	104.9"	104.9"	104.9"	104.9"	104.9"
B. Width — With mirrors extended	110.0"	110.0"	110.0"	110.0"	110.0"	110.0"	110.0"	110.0"
C. Ground clearance — F-250 SRW	8.5"/8.2"	8.5"/8.2"	8.5"/8.1"	8.5"/8.1"	8.5"/8.1"	8.5"/8.2"	8.5"/8.2"	8.5"/8.1"
C. Ground clearance — F-350 SRW	8.5"/8.2"	8.5"/8.2"	8.5"/8.2"	8.5"/8.2"	8.5"/8.2"	8.1"/8.0"	—	8.5"/8.2"
C. Ground clearance — F-350 DRW	8.1"/8.0"	—	8.1"/8.0"	—	—	—	—	8.0"/8.0"
C. Ground clearance — F-450 DRW	—	—	—	—	—	—	—	8.0"
D. Load floor height — F-250 SRW	35.2"/36.3"	34.8"/35.6"	34.4"/35.4"	34.2"/35.1"	34.1"/35.0"	34.7"/38.5"	—	34.1"/35.0"
D. Load floor height — F-350 SRW	34.7"/38.5"	34.4"/37.9"	34.1"/38.0"	33.9"/37.8"	33.8"/37.7"	35.0"/36.4"	—	33.8"/37.7"
D. Load floor height — F-350 DRW	35.0"/36.4"	—	34.3"/35.7"	—	—	—	—	34.1"/35.6"
D. Load floor height — F-450 DRW	—	—	—	—	—	—	—	35.4"
E. Cargo box height	20.0"	20.0"	20.0"	20.0"	20.0"	20.0"	20.0"	20.0"
F. Length	227.6"	232.4"	248.6"	246.8"	263.0"	227.6"	232.4"	248.6"
G. Overhang — Rear	52.4"	52.4"	52.4"	52.4"	52.4"	52.4"	52.4"	52.4"
H. Wheelbase	137.0"	141.8"	158.0"	156.2"	172.4"	137.0"	141.8"	158.0"
I. Overhang — Front	38.1"	38.1"	38.1"	38.1"	38.1"	38.1"	38.1"	38.1"
J. Angle of departure — F-250 SRW	17.8°/19.2°	17.4°/18.5°	17.0°/18.3°	16.7°/18.0°	16.7°/17.9°	17.3°/21.5°	—	16.3°/20.8°
J. Angle of departure — F-350 SRW	17.3°/21.5°	17.0°/20.9°	16.6°/21.1°	16.4°/20.8°	16.4°/20.8°	17.6°/19.3°	—	16.7°/18.5°
J. Angle of departure — F-350 DRW	17.6°/19.3°	—	16.9°/18.7°	—	—	—	—	16.7°/18.5°
J. Angle of departure — F-450 DRW	—	—	—	—	—	—	—	18.3°
K. Ramp breakover angle — F-250 SRW	17.5°/20.4°	16.9°/19.8°	15.8°/18.1°	15.7°/18.1°	15.0°/17.3°	17.2°/21.5°	—	14.8°/18.2°
K. Ramp breakover angle — F-350 SRW	17.2°/21.5°	16.7°/20.9°	15.6°/19.2°	15.5°/19.2°	14.8°/18.2°	17.5°/20.4°	—	15.0°/17.4°
K. Ramp breakover angle — F-350 DRW	17.5°/20.4°	—	15.9°/18.6°	—	—	—	—	17.0°
K. Ramp breakover angle — F-450 DRW	—	—	—	—	—	—	—	17.0°
L. Angle of approach — F-250 SRW	18.0°/19.4°	18.1°/20.1°	18.7°/20.0°	18.7°/20.0°	18.9°/20.6°	18.2°/19.2°	—	19.1°/20.3°
L. Angle of approach — F-350 SRW	18.1°/18.8°	18.2°/19.5°	18.8°/19.3°	18.8°/19.3°	19.0°/20.0°	—	—	19.8°
L. Angle of approach — F-350 DRW	18.2°/19.2°	—	19.0°/20.6°	—	—	—	—	—
L. Angle of approach — F-450 DRW	—	—	—	—	—	—	—	—
Interior								
Front head room	40.7"	40.7"	40.7"	40.7"	40.7"	40.7"	40.7"	40.7"
Front shoulder room	68.0"	68.0"	68.0"	68.0"	68.0"	68.0"	68.0"	68.0"
Front hip room	67.6"	67.6"	67.6"	67.6"	67.6"	67.6"	67.6"	67.6"
Front leg room	41.1"	41.1"	41.1"	41.1"	41.1"	41.1"	41.1"	41.1"
Rear head room	—	38.1"	38.1"	40.8"	40.8"	—	—	40.8"
Rear shoulder room	—	68.1"	68.1"	68.0"	68.0"	—	—	68.0"
Rear hip room	—	67.3"	67.3"	67.6"	67.6"	—	—	67.6"
Rear leg room	—	31.6"	31.6"	42.1"	42.1"	—	—	42.1"
Cargo Box								
Volume (cu. ft.)	77.3	64.1	77.3	64.1	77.3	77.3	64.1	77.3
M. Length at floor	98.0"	81.8"	98.0"	81.8"	98.0"	98.0"	81.8"	98.0"
N. Width at wheelhouse	50.9"	50.9"	50.9"	50.9"	50.9"	50.9"	50.9"	50.9"
O. Width at floor (maximum)	69.3"	69.3"	69.3"	69.3"	69.3"	69.3"	69.3"	69.3"

SRW = single rear wheel DRW = dual rear wheel SWB = short wheelbase (6¾' cargo box) LWB = long wheelbase (8' cargo box)

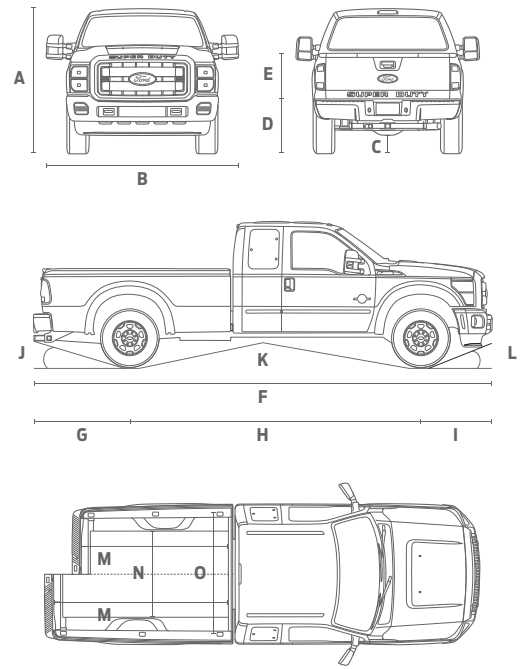

INTERIOR STORAGE (cu. ft.)

Front 40/20/40 split seat center under-seat lockable storage	0.36
Front flow-through center console main bin	1.23
Rear Crew Cab 60/40 split bench lockable under-seat storage	1.17

TRANSMISSION

Type	6-speed SelectShift Automatic™	
Case material	Aluminum	
PTO	Live-drive access on driver's side (diesel only)	
Gear ratios	1st	3.97:1
	2nd	2.32:1
	3rd	1.52:1
	4th	1.15:1
	5th	0.86:1
	6th	0.67:1
	Reverse	3.13:1

CONVENTIONAL TOWING — MAXIMUM LOADED TRAILER WEIGHT RATINGS (lbs.)

Engine	Axle Ratio	GCWR	Regular Cab					SuperCab					Crew Cab					
			F-250/ F-350 SRW 4x2	F-350 DRW 4x2	F-250 SRW 4x4	F-350 SRW 4x4	F-350 DRW 4x4	F-250/ F-350 SRW 4x2	F-350 DRW 4x2	F-250 SRW 4x4	F-350 SRW 4x4	F-350 DRW 4x4	F-250/ F-350 SRW 4x2	F-350 DRW 4x2	F-250 SRW 4x4	F-350 SRW 4x4	F-350 DRW 4x4	F-450 DRW 4x4
6.2L 2-valve FFV	3.73	19,000	12,500	—	12,500	12,400	—	12,500	—	12,200	12,100	—	12,400	—	12,000	12,000	—	—
	4.30	19,500	—	12,900	—	12,500	—	12,500	—	12,500	—	12,100	—	12,300	—	11,900	—	—
6.7L V8 Turbo Diesel	3.31	23,500	12,500	—	12,500	12,500	—	14,000	—	14,000	14,000	—	14,000	—	14,000	14,000	—	—
	3.55	23,500	12,500	—	12,500	12,500	—	14,000	—	14,000	14,000	—	14,000	—	14,000	14,000	—	—
	3.73	30,000	—	15,000	—	—	15,000	—	15,000	—	—	15,000	—	17,500	—	—	17,500	—
	4.30	33,000	—	—	—	—	—	—	—	—	—	—	—	—	—	—	—	17,500



TECHNICAL SPECIFICATIONS

POWERTRAINS

	6.2L 2-Valve Gas ¹	6.7L V8 Turbo Diesel
Configuration	SOHC	OHV (32-valve)
Fuel injection	Sequential Electronic	High-Pressure Common-Rail
Engine control system	Electronic	Electronic
Induction system	Specially tuned	Single-Sequential Turbocharger; charged air cooler
Battery	12-volt; 650-cca/72-amp-hr	Dual 12-volt; 750-cca/78-amp-hr
Alternator	157-amp	157-amp (Single 200-amp or dual combined 357-amp, optional)
Cooling system	Pressurized series flow	Pressurized series flow
Oil-life monitor	Oil-minder system	Intelligent Oil-Life Monitor™
Cylinders	8	8
Cylinder head	Aluminum	Aluminum
Block material	Cast iron	Compacted graphite iron
Valve operation	Roller rocker shaft	Push rod/rocker arms
Camshaft drive	Silent chain	Gear
Bore/Stroke	4.02"/3.74"	3.90"/4.25"
Compression ratio	9.8:1	16.2:1
Horsepower/rpm	385 @ 5,500 ² /316 @ 4,179 ³	400 @ 2,800
Torque lb.-ft./rpm	405 @ 4,500 ² /397 @ 4,179 ³	800 @ 1,600
Recommended fuel	Regular unleaded or E85	Ultra-Low-Sulfur Diesel or B20 (containing 20% or less biodiesel)

¹Certified to SAE J1349. ²Under 10,000 lbs. GVWR. ³Over 10,000 lbs. GVWR.

MECHANICAL

Front Suspension	
Type	Twin-I-Beam (F-250/F-350 4x2); solid Twin-Coil Monobeam axle (F-250/F-350 4x4, F-450 4x4)
Axle (rating @ ground)	5,250 lbs. (F-250/F-350 4x2); 6,000 lbs. (F-250/F-350/F-450 4x4)
Springs	Coil
Shock absorbers	1.38" gas type
Stabilizer bar	Standard
Rear Suspension	
Type	Solid axle
Axle (rating @ ground)	6,200 lbs. (F-250); 7,180 lbs. (F-350 SRW); 9,650 lbs. (F-350 DRW); 9,650 lbs. (F-450)
Springs	Leaf
Shock absorbers	1.38" gas type
Stabilizer bar	Standard on DRW pickup; optional in package on SRW pickup
Steering	
Assist	Power
Overall ratio	20.49:1 (F-250/F-350 4x2); 20.41:1 (F-250/F-350 4x4); 20.41:1 average (F-450)
Brakes	
Type	4-wheel vented-disc ABS (standard)
Front (rotor diameter)	13.66" (F-250/F-350); 14.53" (F-450)
Rear (rotor diameter)	13.39" (F-250/F-350); 15.35" (F-450)
Wheels	
Type	Steel or aluminum
Size	17" 18" or 20" (F-250/F-350); 17" (F-450)
Number of studs	8
Bolt-circle diameter	6.7" (170-mm) SRW; 7.87" (200-mm) F-350 DRW; 7.87" (200-mm) F-450

5TH-WHEEL TOWING — MAXIMUM LOADED TRAILER WEIGHT RATINGS (lbs.)

Automatic Transmission			Regular Cab						SuperCab						Crew Cab						
Engine	Axle Ratio	GCWR	F-250 SRW 4x2	F-350 SRW 4x2	F-350 DRW 4x2	F-250 SRW 4x4	F-350 SRW 4x4	F-350 DRW 4x4	F-250 SRW 4x2	F-350 SRW 4x2	F-350 DRW 4x2	F-250 SRW 4x4	F-350 SRW 4x4	F-350 DRW 4x4	F-250 SRW 4x2	F-350 SRW 4x2	F-350 DRW 4x2	F-250 SRW 4x4	F-350 SRW 4x4	F-350 DRW 4x4	F-450 DRW 4x4
6.2L 2-valve FFV	3.73	19,000	12,800	12,700	—	12,300	12,300	—	12,500	12,400	—	12,100	12,000	—	12,300	12,200	—	11,900	11,900	—	—
	4.30	19,500	—	—	12,800	—	—	12,400	—	—	12,400	—	—	12,000	—	—	12,200	—	—	11,700	—
		22,000	15,800	15,700	—	15,300	15,300	—	15,500	15,400	—	15,100	15,000	—	15,300	15,200	—	14,900	14,900	—	—
		22,500	—	—	15,800	—	—	15,400	—	—	15,400	—	—	15,000	—	—	15,200	—	—	14,700	—
6.7L V8 Turbo Diesel	3.31	23,500	16,700	16,600	—	16,200	16,100	—	16,300	16,300	—	16,000	15,900	—	16,100	16,100	—	15,200	15,700	—	—
	3.55	23,500	16,700	16,600	—	16,200	16,100	—	16,300	16,300	—	16,000	15,900	—	16,100	16,100	—	15,200	15,700	—	—
	3.73	30,000	—	—	22,700	—	—	22,200	—	—	22,100	—	—	21,700	—	—	21,900	—	—	21,500	—
	4.30	33,000	—	—	—	—	—	—	—	—	—	—	—	—	—	—	—	—	—	—	24,500

MAXIMUM PAYLOAD WEIGHT RATINGS (lbs.)

	Max. GVWR	Regular Cab		SuperCab		Crew Cab	
		137.0" WB	141.8" WB	158.0" WB	156.2" WB	172.4" WB	
F-250 SRW 4x2	9,900	4,190	3,800	3,700	3,590	3,480	
	10,000	4,290	3,900	3,800	3,690	3,580	
F-250 SRW 4x4	9,900	3,650	3,390	3,280	3,190	3,070	
	10,000	3,790	3,490	3,380	3,290	3,170	
F-350 SRW 4x2	10,000	4,140	3,830	3,760	3,650	3,510	
	10,500	4,630	4,280	—	—	4,010	
	10,700	—	3,860	—	4,220	—	
	10,900	—	—	4,540	—	—	
	11,000	4,430	4,110	—	—	4,460	
	11,400	—	—	—	4,330	—	
	11,500	—	—	4,470	—	4,260	
F-350 SRW 4x4	10,000	3,690	3,430	3,340	3,260	3,130	
	11,000	3,990	—	4,250	—	4,080	
	11,100	4,690	4,430	—	—	—	
	11,200	—	3,930	3,800	3,790	4,230	
	11,300	4,940	—	3,850	4,460	3,630	
	11,500	4,440	4,190	4,010	4,000	3,790	
F-350 DRW 4x2	13,300	7,110	—	6,640	—	6,410	
F-350 DRW 4x4	13,000 ⁴	—	—	—	—	5,320	
	13,300	6,610	—	6,210	—	5,990	
F-450 DRW 4x4	13,300	—	—	—	—	5,260	

WB = wheelbase

⁴Requires pickup box delete.





QUALITY, GREEN, SAFE AND SMART.

ford.com

New Vehicle Limited Warranty. We want your Ford F-Series Super Duty® ownership experience to be the best it can be. Under this warranty, your new vehicle comes with 3-year/36,000-mile bumper-to-bumper coverage, 5-year/60,000-mile Powertrain Warranty coverage, 5-year/50,000-mile safety restraint coverage, and 5-year/unlimited-mile corrosion (perforation) coverage – all with no deductible. Please ask your Ford Dealer for a copy of this limited warranty. □ **Roadside Assistance.** Covers your vehicle for 5 years or 60,000 miles, so you have the security of knowing that help may be only a phone call away should you run out of fuel, lock yourself out of the vehicle or need towing. Your Ford Dealer can provide complete details on all of these advantages. □ **Ford Credit.** Get the ride you want. Whether you plan to lease or finance, you'll find the choices that are right for you at Ford Credit. Ask your Ford Dealer for details or check us out at fordcredit.com. □ **Ford Extended Service Plan.** For a purchase or lease, the Ford Extended Service Plan (ESP) gives you "Peace-of-Mind" protection designed to cover key vehicle components and protect you from the cost of unexpected repairs. Ask your dealer for a Ford ESP, the only service contract backed exclusively by Ford and honored at all Ford dealerships. □ **Insurance Services.** Get Ford Motor Company quality in your auto insurance. Our program offers industry-leading benefits and competitive rates. Call 1-877-367-3847, or visit us at fordvip.com for a no-obligation quote. Insurance offered by American Road Services Company (in CA, American Road Insurance Agency), a licensed agency and subsidiary of Ford Motor Company. □ **Genuine Ford Accessories** will be warranted for whichever provides you the greatest benefit: 12 months or 12,000 miles (whichever occurs first), or the remainder of your Bumper-to-Bumper 3-year/36,000-mile New Vehicle Limited Warranty. Ford Licensed Accessories (FLA) are warranted by the accessory manufacturer's warranty. FLA are fully designed and developed by the accessory manufacturer and have not been designed or tested to Ford Motor Company engineering requirements. Contact your Ford Dealer for details and/or a copy of all limited warranties.

