



TAYLOR-WAY

Since 1946



**REPUTATION
BUILT ON
QUALITY
VALUE &
PERFORMANCE**

“DO IT THE TAYLOR-WAY”

Taylor Pittsburgh Mfg. • Athens, TN • (423) 745-3110

Series 923 / 962 / 972 Gear Driven Rotary Tiller

Taylor-Way Gear-Driven Rotary Tillers have a rugged, reinforced main frame for years of dependable service. Available in sizes 4' to 7' wide.

The heavy duty gear drive operates in an oil bath for dependable performance and reduced maintenance.

6-tines per flange requires less horsepower yet operates smoothly, especially in tough conditions.

Standard slip clutch 540 RPM drive line provides protection for drive components.

Tilling depth controlled by adjustable skid shoes — to a maximum 8" depth.

Standard heavy-duty rear deflector provides improved leveling and soil finish.

Patented Kickstand.



540 RPM Slipclutch drive line standard on Taylor-Way tillers.



Tilling depth is controlled by adjustable skid shoes - to a maximum 8" depth.



Heavy duty gear drive gives smooth reliable performance. Oil bath operation provides constant lubrication for long life.

962 Series Tillers

Taylor Pittsburgh 962 Series Tillers are built to perform year after year. There's a certain satisfaction that comes from doing the job right. Whether you have tough sod, or hard compacted ground, Taylor Pittsburgh's Gear Drive Rotary Tillers will get the job done. Producing an ideal soil mix is what Taylor Pittsburgh's Tillers are all about. With six tines per flange, you can till down to eight inches. The 962-GDT-48 (48") is ideal for 20-35 horse power tractors. The 962-GDT-60 (60") is designed for the most popular tractors in the 25-40 horse power range. Choose the 962-GDT-72 (72") model for tractors with 35-50 horse power. The 48", 60" & 72" comes with a Cat. I, 3-point hitch. The 962-GDT-84 (84") is perfect for larger operations and ideal for use on tractors from 50-65 horse power and will hook to a Cat. I or II, 3-point hitch. The choice is yours, quality Gear Drive Rotary Tillers that are built tough and will give you years of dependable performance.



962-GDT



962-GDT-84

"DO IT THE TAYLOR-WAY"

Taylor Pittsburgh Mfg. • Athens, TN • (423) 745-3110



972-RGDT

923 Series Sub-Compact Tillers

Get more work out of your sub-compact tractor with the Taylor Pittsburgh Sub Compact Gear Drive Rotary Tiller. The 923-GDT-48 (48"), for sub compact tractors up to 25 horse power and the 923-GDT-54 (54") for small compact & large sub-compact tractors up to 35 horse power, both have all the quality features of the full size tillers. The heavy duty frame and six tines per flange produce a better seedbed. A slip clutch PTO shaft transfer's power smoothly to the gear driven center and side gearboxes.



923-GDT

Model	923-GDT-48 / 923-GDT-54	962-GDT-48	962-GDT-60 / 972-RGDT-60	962-GDT-72 / 972-RGDT-72	962-GDT-84
Working Width	48" / 54"	48"	60" / 60"	72" / 72"	84"
Max. Tilling Depth	8"	8"	8"	8"	8"
Drive Type	Gear Drive	Gear Drive	Gear Drive / Reverse Gear Drive	Gear Drive / Reverse Gear Drive	Gear Drive
Flanges	6	6	7	9	11
Number of Blades	36	36	42	54	66
Hitch	Limited Cat I	Cat. I	Cat. I	Cat. I	Cat. I & II
Drive Line Protection	HD Drive Line With Slip Clutch	HD Drive Line With Slip Clutch	HD Drive Line With Slip Clutch	HD Drive Line With Slip Clutch	HD Drive Line With Slip Clutch
Approx. Weight	489 lbs. / 520 lbs.	575 lbs.	630 lbs. / 639 lbs.	721 lbs. / 731 lbs.	860 lbs.
Min. HP Req.	15 / 20	20	25 / 30	35 / 40	50
Max. HP Req.	Up to 25 / Up to 35	35	40 / 45	50 / 55	65

Series 233 Tandem Disc Harrow



The Taylor Pittsburgh Disc Harrows are field tested and built to last. They are great for use in gardens and wildlife plots as well as vineyards and small acreage farms.



STANDARD FEATURES

- Accommodates Cat. I Quick Hitch
- 1" Square High Carbon Steel Axles
- Cast Iron Disc Spacers
- Adjustable Axle Angle Settings
- Sealed Ball Bearings

Box Frame Disc Harrow

STANDARD FEATURES

- Accommodates Cat. I Quick Hitch
- Heavy Duty 3" Square Tubing Frame
- 7 1/2" Blade Spacing
- EZ Cutting Angle Adjustments
- 1" Square High Carbon Steel Axles
- Sealed Ball Bearings
- Cast Iron Disc Spacers
- Adjustable Gang Angle: 0°, 15°, 30°



Angle Frame Disc Model	Width	Approx. Ship Wt.	HP Range
233-16-12-G-SB-C	4 1/2'	405 lbs.	20 - 30 HP
233-16-12-G-SB-N	4 1/2'	401 lbs.	20 - 30 HP
233-16-16-G-SB-C	5 1/2'	466 lbs.	20 - 35 HP
233-16-16-G-SB-N	5 1/2'	460 lbs.	20 - 35 HP
233-18-16-G-SB-C	5 1/2'	502 lbs.	20 - 35 HP
233-18-16-G-SB-N	5 1/2'	497 lbs.	20 - 35 HP
233-16-20-G-SB-C	6 1/2'	529 lbs.	25 - 40 HP
233-16-20-G-SB-N	6 1/2'	524 lbs.	25 - 40 HP
233-18-20-G-SB-C	6 1/2'	592 lbs.	25 - 40 HP
233-18-20-G-SB-N	6 1/2'	567 lbs.	25 - 40 HP

Box Frame Disc Model	Width	Approx. Ship Wt.	HP Range
233-18-16-G-CBF	5 1/2'	764 lbs.	30 - 45 HP
223-18-16-G-NBF	5 1/2'	735 lbs.	30 - 45 HP
233-18-20-G-CBF	6 1/2'	857 lbs.	35 - 60 HP
233-18-20-G-NBF	6 1/2'	823 lbs.	35 - 60 HP
233-18-24-G-CBF	7 1/2'	863 lbs.	40 - 75 HP
233-18-24-G-NBF	7 1/2'	830 lbs.	40 - 75 HP
233-20-20-G-CBF	6 1/2'	909 lbs.	40 - 75 HP
233-20-20-G-NBF	6 1/2'	874 lbs.	40 - 75 HP
233-20-24-G-CBF	7 1/2'	1012 lbs.	45 - 75 HP
233-20-24-G-NBF	7 1/2'	985 lbs.	45 - 75 HP

N = Notched Blades C = Combination (Notched Front and Round Rear Blades)

“DO IT THE TAYLOR-WAY”

Taylor Pittsburgh Mfg. • Athens, TN • (423) 745-3110

Series 377 Tandem and 600 Offset Disc Harrow

The Series 377 Tandem Disc and 600 Offset Disc Harrows are designed for medium to low acreage applications. Suitable for tractors from 30-60 HP. These discs feature a tubular frame in a weight class rugged enough for the farmer or landscaper, yet economical enough for the part-timer.

Model	Number of Discs	Blade Diameter	Disc Spacing	Working Width	Approx. Weight	DB HP Required
377-16-18-CF-77	16	18"	7 ½"	5 ½'	808 lbs.	30 HP
377-16-20-CF-77	16	20"	7 ½"	5 ½'	908 lbs.	30 HP
377-20-18-CF-77	20	18"	7 ½"	6 ½'	823 lbs.	40 HP
377-20-20-CF-77	20	20"	7 ½"	6 ½'	913 lbs.	40 HP
377-24-18-CF-77	24	18"	7 ½"	7 ½'	914 lbs.	50 HP
377-24-20-CF-77	24	20"	7 ½"	7 ½'	935 lbs.	50 HP

CO = Notched Blades CF = Combination (Notched Front and Round Rear Blades)

Drawbar H.P. requirements are approximate and depend greatly on soil type.

STANDARD FEATURES

- Heavy-Duty 3" x 3" Tubular Steel Frame
- 7 ½" Blade Spacing (9" Spacing Optional)
- 1" Square High Carbon Gang Axles
- Sealed Ball Bearings
- Durable Cast Spacer Spools
- Cat. I Straddle Mount, 3-Point Hitch
- Adjustable Gang Angle: 2.3°, 11.3°, 20.9°, 27.8°
- Available with all Cut Out, or Combination Discs
- Other Models Available

377 Series Tandem



Model	Number of Discs	Blade Diameter	Disc Spacing	Working Width	Approx. Weight	DB HP Required
600-17-22 CO-9	17	20"	9"	6' 6"	953 lbs.	40 HP
600-19-22 CO-7	19	22"	7 ½"	5' 4"	980 lbs.	45 HP
600-21-20 CO-7	21	20"	7 ½"	6' 6"	935 lbs.	50 HP
600-21-22 CO-7	21	22"	7 ½"	6' 6"	1040 lbs.	60 HP

CO = Notched Blades CF = Combination (Notched Front and Round Rear Blades)

STANDARD FEATURES

- Main Frame Constructed from ¼" x 3" x 3" Tubing
- 1" Square High Carbon Gang Axles
- Cat. I Straddle Mount, 3-Point Hitch
- Maintenance Free Sealed Bearings
- Rigid Bearing Hangers
- Adjustable Gang Angles from 10°-28°
- Available with 20" or 22" Cut Out Blades

600 Series Offset



Drawbar H.P. requirements are approximate and depend greatly on soil type.



TAYLOR-WAY

Series 650 Heavy Duty Offset Disc Harrow

Proven and precise, the Taylor-Way 650 Heavy Duty Offset Disc Harrow is the premium implement when you want customized options and power to get the job done right. The offset configuration provides maximum pulverization for primary as well as secondary tillage applications. Design features include heavy tubular frame construction, 1 1/2" square gang axles for strength and trunion mounted re-greasable bearings.

Heavy duty with superior leveling capabilities, the 650 encompasses a broad range of cutting widths and blade spacings to select. That means you'll never have to sacrifice what you really want from your implement when you choose a Taylor-Way. Whether you need the 9" spacing or 10 1/2" spacing, you'll feel like this Disc Harrow was custom built just for you.



Telescopic tongue for easy adjustment of side draft



Optional
1" x 2" flexible steel hanger design to absorb shock load for increased bearing and axle life



Tapered blades to improve leveling (2" front and 4" rear)

Extra Equipment Available:
Gang Bolt Wrench

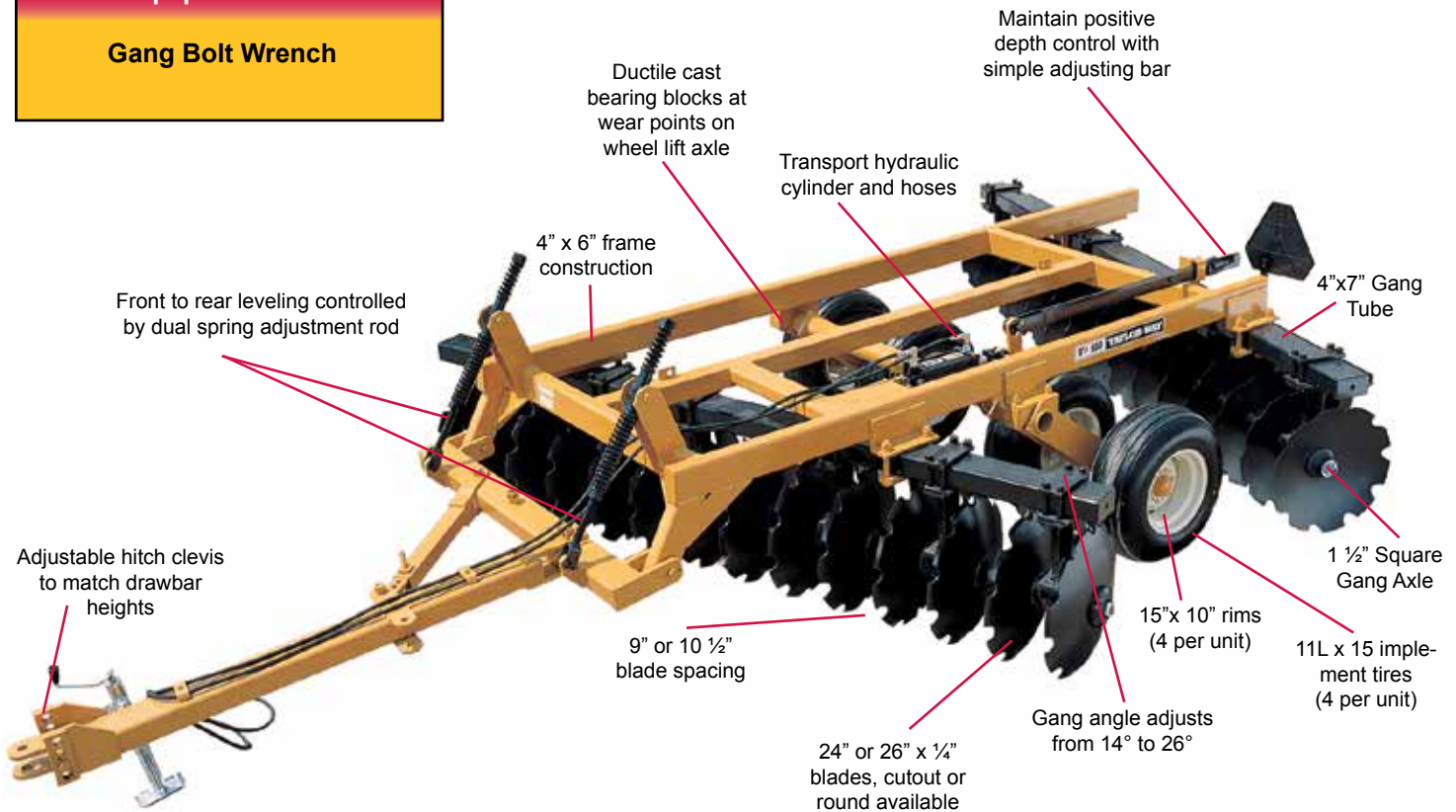

"DO IT THE TAYLOR-WAY"

Taylor Pittsburgh Mfg. • Athens, TN • (423) 745-3110

Offset Disc Harrow – 9" Disc Spacing

Cutting Width	Bearing Hanger Type	Number of Discs	Approx. Unit Wt. 24" Blades	Number of Bearings	Approx. DB HP
9' 1"	Rigid	25	4,895 lbs.	8	80 HP
9' 1"	Flex	25	4,980 lbs.	8	80 HP
10' 7"	Rigid	29	5,170 lbs.	12	100 HP
10' 7"	Flex	29	5,310 lbs.	12	100 HP
12' 0"	Rigid	33	5,590 lbs.	8	120 HP
12' 0"	Flex	33	5,730 lbs.	8	120 HP
14' 1"	Rigid	39	7,005 lbs.	16	140 HP
14' 1"	Flex	39	7,195 lbs.	16	140 HP
16' 3"	Rigid	45	7,615 lbs.	18	160 HP
16' 3"	Flex	45	7,830 lbs.	18	160 HP
17' 8"	Rigid	49	8,070 lbs.	20	180 HP
17' 8"	Flex	49	8,310 lbs.	20	180 HP

Offset Disc Harrow – 10 ½" Disc Spacing

Cutting Width	Bearing Hanger Type	Number of Discs	Approx. Unit Wt. 24" Blades	Number of Bearings	Approx. DB HP
8' 9"	Rigid	21	4,550 lbs.	8	80 HP
8' 9"	Flex	21	4,645 lbs.	8	80 HP
10' 5"	Rigid	25	5,015 lbs.	8	100 HP
10' 5"	Flex	25	5,110 lbs.	8	100 HP
12' 1"	Rigid	29	5,480 lbs.	12	120 HP
12' 1"	Flex	29	5,620 lbs.	12	120 HP
14' 7"	Rigid	35	6,915 lbs.	14	140 HP
14' 7"	Flex	35	7,080 lbs.	14	140 HP
16' 3"	Rigid	39	7,380 lbs.	16	160 HP
16' 3"	Flex	39	7,570 lbs.	16	160 HP
17' 11"	Rigid	43	7,845 lbs.	18	180 HP
17' 11"	Flex	43	8,060 lbs.	18	180 HP

Equipment & Accessory Specifications

650 Series Item	Specification
Cutting Width Range	8' 9" to 17' 11"
Av. Wt. Per Blade	186 lbs.
Disc Spacing	9" or 10 ½"
Blade Diameter	24" or 26"
Blade Thickness	¼"
Transport Cylinder/Hoses	5" x 8" Double Acting Standard
Tongue Jack	3000 lbs. Standard
Gang Bolt Wrench	Optional

Series 670 Offset Disc Harrow

The Taylor-Way 670 Offset Disc Harrow is the result of proven, field tested engineering to give you precision performance in a variety of applications. This heavy duty Harrow is ideal for light and heavy field tillage, firebreak cutting and many orchard applications. The offset design enables maximum penetration and even tillage of soil.

With over 12 widths to choose from, each available in standard or flex bearing hanger type, the 670 Series can easily be customized to meet your specific application and HP needs. The heavy construction features 1 1/2" square gang axles and common gang components of our larger models, making the 670 one of the most durable and dependable Harrows in its class. Outstanding features and popular options from a name you trust...Taylor-Way.



Telescopic tongue for easy adjustment of side draft



Front to rear leveling controlled by simple spring adjustment rod



Optional
1" x 2" flexible steel hanger design to absorb shock load for increased bearing and axle life

Extra Equipment Available:
Gang Bolt Wrench
Third Wheel Kit

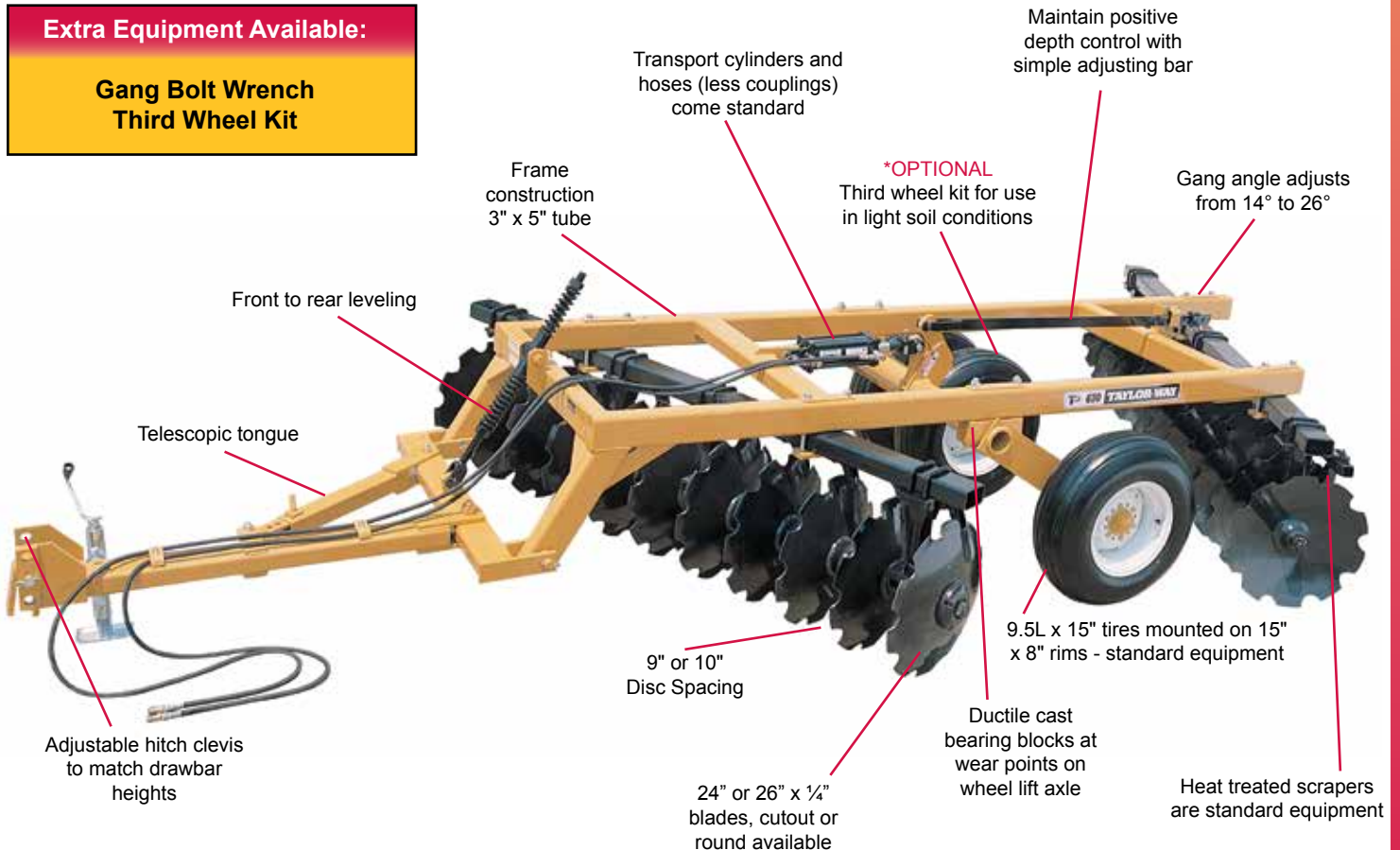

"DO IT THE TAYLOR-WAY"

Taylor Pittsburgh Mfg. • Athens, TN • (423) 745-3110

Offset Disc Harrow – 9" Disc Spacing

Cutting Width	Bearing Hanger Type	Number of Discs	Unit Weight	Number of Bearings	Approx. DB Hp
5' 6"	Rigid	15	2,620 lbs.	4	40 HP
5' 6"	Flex	15	2,670 lbs.	4	40 HP
6' 3"	Rigid	17	2,855 lbs.	8	45 HP
6' 3"	Flex	17	2,925 lbs.	8	45 HP
6' 11"	Rigid	19	3,010 lbs.	8	50 HP
6' 11"	Flex	19	3,080 lbs.	8	50 HP
7' 7"	Rigid	21	3,175 lbs.	8	55 HP
7' 7"	Flex	21	3,235 lbs.	8	55 HP
8' 4"	Rigid	23	3,320 lbs.	8	60 HP
8' 4"	Flex	23	3,390 lbs.	8	60 HP
9' 0"	Rigid	25	3,685 lbs.	8	65 HP
9' 0"	Flex	25	3,775 lbs.	8	65 HP
9' 9"	Rigid	27	3,740 lbs.	10	70 HP
9' 9"	Flex	27	3,830 lbs.	10	70 HP

Offset Disc Harrow – 10" Disc Spacing

Cutting Width	Bearing Hanger Type	Number of Discs	Unit Weight	Number of Bearings	Approx. DB HP
5' 11"	Rigid	15	2,855 lbs.	4	45 HP
5' 11"	Flex	15	2,925 lbs.	4	45 HP
6' 9"	Rigid	17	3,010 lbs.	8	50 HP
6' 9"	Flex	17	3,080 lbs.	8	50 HP
7' 9"	Rigid	19	3,175 lbs.	8	55 HP
7' 9"	Flex	19	3,235 lbs.	8	55 HP
8' 4"	Rigid	21	3,320 lbs.	8	60 HP
8' 4"	Flex	21	3,390 lbs.	8	60 HP
9' 1"	Rigid	23	3,685 lbs.	8	65 HP
9' 1"	Flex	23	3,775 lbs.	8	65 HP
9' 11"	Rigid	25	3,740 lbs.	8	70 HP
9' 11"	Flex	25	3,825 lbs.	8	70 HP

Equipment & Accessory Specifications

670 Series Item	Specification
Cutting Width Range	5' 6" to 9' 11"
Av. Wt. Per Blade	156 lbs.
Disc Spacing	9" or 10"
Blade Diameter	24" or 26" (Cutout or Round)
Blade Thickness	1/4"
Tongue Jack	3000 lbs. Standard
Gang Bolt Wrench	Optional
Third Wheel Kit	Optional

Series 350 Wheel-Type Wing Fold Tandem Disc Harrow

Built for outstanding cutting and leveling, the Taylor-Way 350 Wing Fold Tandem Disc Harrow is one of the most heavy duty and versatile implements available. Backed by years of Taylor-Way experience, it's durability will speak for itself when you see the premium construction and features.

With nearly 40 options in narrow and wide frame configurations, the 350 is not only engineered for performance, but the hydraulic assisted wing fold design makes maneuverability and transport simple...all done right from your tractor seat!

Even in the toughest soil conditions, the sturdy frame adds stability and weight where you need it most. High carbon, square gang axles are built to deliver maximum penetration, while all the disc and spool spacing options help maintain clearance and optimum pulverization. You can trust your biggest jobs to the Taylor-Way 350.



Optional

1" x 2" flexible steel hanger design to absorb shock load for increased bearing and axle life

Extra Equipment Available:

Gang Bolt Wrench
Furrow Filler Scraper

Equipment & Accessory Specifications

350 Series Item	Specification
Cutting Width Range	14' 10" to 21' 11"
Avg. Wt. Per Blade	119 lbs.
Narrow - Transport Width	10' 6"
Wide - Transport Width	14' 6"
Narrow Frame Wheel Tread	100" Width
Wide Frame Wheel Tread	136" Width
Disc Spacing	7 1/2" or 9"
Blade Diameter	22"
Blade Thickness	6 Gauge
Transport Cylinder/Hoses	4" x 8" Standard (to manifold)
Wing Cylinders/Hoses	2 1/2" x 16" Standard (to manifold)
Tongue Jack	3000 lbs. Standard

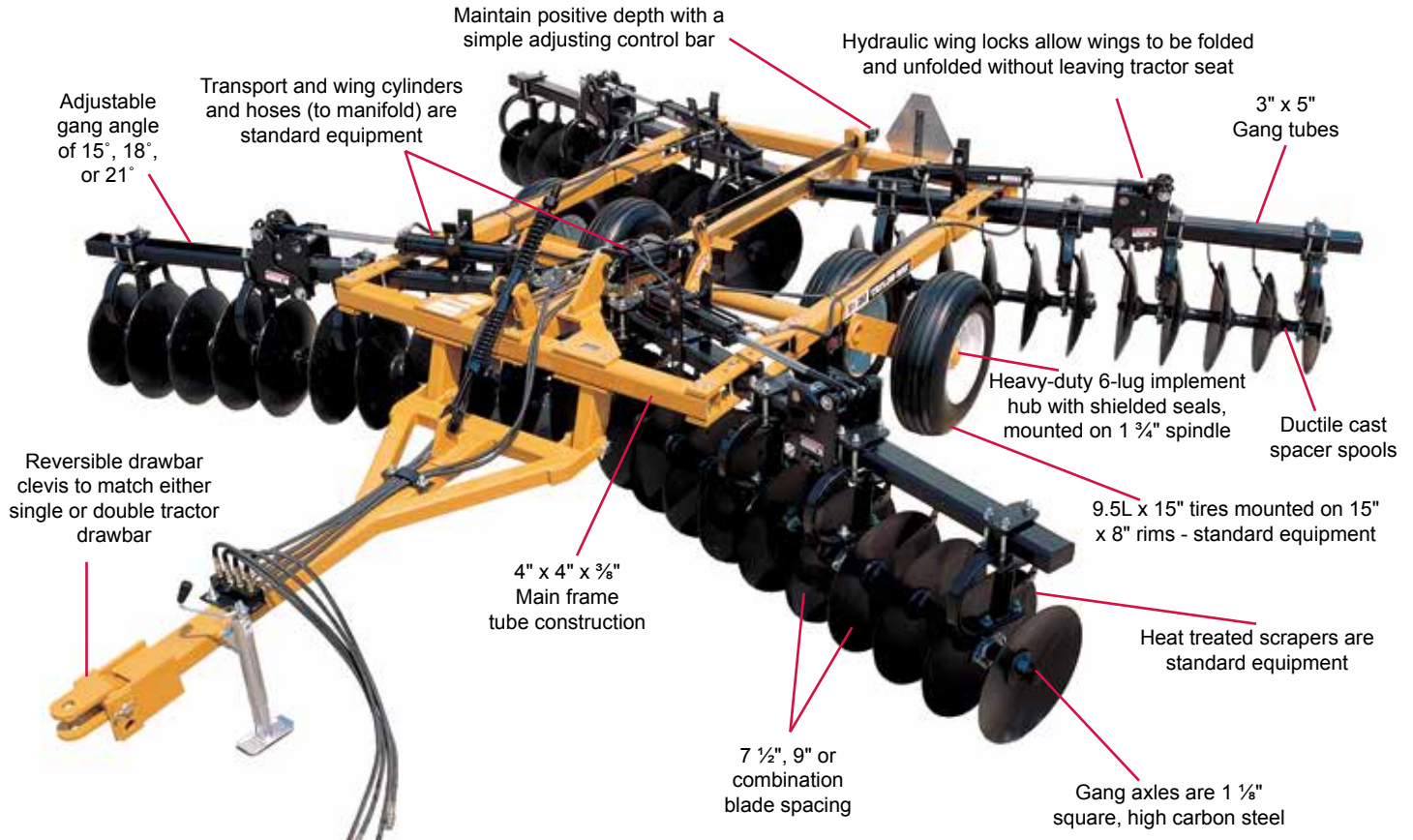

“DO IT THE TAYLOR-WAY”

Taylor Pittsburgh Mfg. • Athens, TN • (423) 745-3110

Narrow Frame – 22" Round Blades / Base Weight 7 ½" Disc Spacing

Cutting Width	Bearing Hanger Type	Disc Spacing	Number of Discs	Approx. Weight	Number of Bearings	Transport Wheels	Wing Size	Approx. DB Hp
15' 1"	Rigid	7.5"	48	5,034 lbs.	16	4	5F / 5R	90
15' 1"	Flex	7.5"	48	5,150 lbs.	16	4	5F / 5R	90
16' 3"	Rigid	7.5"	52	5,239 lbs.	16	4	6F / 6R	95
16' 3"	Flex	7.5"	52	5,399 lbs.	16	4	6F / 6R	95
17' 5"	Rigid	7.5"	56	5,487 lbs.	16	4	7F / 7R	100
17' 5"	Flex	7.5"	56	5,647 lbs.	16	4	7F / 7R	100

Narrow Frame – 22" Round Blades / Base Weight 9" Disc Spacing

Cutting Width	Bearing Hanger Type	Disc Spacing	Number of Discs	Approx. Weight	Number of Bearings	Transport Wheels	Wing Size	Approx. DB HP
14' 10"	Rigid	9"	40	4,769 lbs.	16	4	4F / 4R	90 HP
14' 10"	Flex	9"	40	4,929 lbs.	16	4	4F / 4R	90 HP
16' 3"	Rigid	9"	44	5,017 lbs.	16	4	5F / 5R	95 HP
16' 3"	Flex	9"	44	5,177 lbs.	16	4	5F / 5R	95 HP
17' 8"	Rigid	9"	48	5,265 lbs.	16	4	6F / 6R	100 HP
17' 8"	Flex	9"	48	5,425 lbs.	16	4	6F / 6R	100 HP

Narrow Frame – 22" Round Blades / Base Weight 9" FT / 7 ½" RR Disc Spacing

Cutting Width	Bearing Hanger Type	Disc Spacing	Number of Discs	Approx. Weight	Number of Bearings	Transport Wheels	Wing Size	Approx. DB HP
15' 1"	Rigid	9" / 7.5"	44	4,882 lbs.	16	4	4F / 5R	90 HP
15' 1"	Flex	9" / 7.5"	44	5,042 lbs.	16	4	4F / 5R	90 HP
16' 3"	Rigid	9" / 7.5"	48	5,130 lbs.	16	4	5F / 6R	95 HP
16' 3"	Flex	9" / 7.5"	48	5,290 lbs.	16	4	5F / 6R	95 HP
17' 5"	Rigid	9" / 7.5"	52	5,369 lbs.	16	4	6F / 7R	100 HP
17' 5"	Flex	9" / 7.5"	52	5,529 lbs.	16	4	6F / 7R	100 HP

Wide Frame – 22" Round Blades / Base Weight 7 ½" Disc Spacing

Cutting Width	Bearing Hanger Type	Disc Spacing	Number of Discs	Approx. Weight	Number of Bearings	Transport Wheels	Wing Size	Approx. DB HP
18' 8"	Rigid	7.5"	60	6,010 lbs.	24	4	5F / 5R	115 HP
18' 8"	Flex	7.5"	60	6,250 lbs.	24	4	5F / 5R	115 HP
19' 10"	Rigid	7.5"	64	6,258 lbs.	24	4	6F / 6R	120 HP
19' 10"	Flex	7.5"	64	6,498 lbs.	24	4	6F / 6R	120 HP
21' 0"	Rigid	7.5"	68	6,506 lbs.	24	4	7F / 7R	125 HP
21' 0"	Flex	7.5"	68	6,746 lbs.	24	4	7F / 7R	125 HP

Wide Frame – 22" Round Blades / Base Weight 9" Disc Spacing

Cutting Width	Bearing Hanger Type	Disc Spacing	Number of Discs	Approx. Weight	Number of Bearings	Transport Wheels	Wing Size	Approx. DB HP
19' 1"	Rigid	9"	52	5,812 lbs.	24	4	4F / 4R	115 HP
19' 1"	Flex	9"	52	6,052 lbs.	24	4	4F / 4R	115 HP
20' 6"	Rigid	9"	56	6,037 lbs.	24	4	5F / 5R	120 HP
20' 6"	Flex	9"	56	6,277 lbs.	24	4	5F / 5R	120 HP
21' 11"	Rigid	9"	60	6,285 lbs.	24	4	6F / 6R	125 HP
21' 11"	Flex	9"	60	6,525 lbs.	24	4	6F / 6R	125 HP

Wide Frame – 22" Round Blades / Base Weight 9" FT / 7 ½" RR Disc Spacing

Cutting Width	Bearing Hanger Type	Disc Spacing	Number of Discs	Approx. Weight	Number of Bearings	Transport Wheels	Wing Size	Approx. DB HP
18' 8"	Rigid	9" / 7.5"	56	5,902 lbs.	24	4	4F / 5R	115 HP
18' 8"	Flex	9" / 7.5"	56	6,142 lbs.	24	4	4F / 5R	115 HP
19' 10"	Rigid	9" / 7.5"	60	6,150 lbs.	24	4	5F / 6R	120 HP
19' 10"	Flex	9" / 7.5"	60	6,395 lbs.	24	4	5F / 6R	120 HP
21' 0"	Rigid	9" / 7.5"	64	6,403 lbs.	24	4	6F / 7R	125 HP
21' 0"	Flex	9" / 7.5"	64	6,643 lbs.	24	4	6F / 7R	125 HP

Series 351 Wheel-Type Tandem Disc Harrow

When it comes to sheer versatility and performance, there's never been a better choice than the Taylor-Way 351 Tandem Disc Harrow. With nearly 40 options in narrow and wide frame configurations, the 351 is engineered with smart features, easy adjustments and customizing extras.

The rigid, tubular frame (4" x 4" x 3/8") design creates the stability and weight you need to achieve outstanding cutting and leveling even in the toughest soil conditions. High carbon, square 1 1/8" gang axles are built to deliver maximum penetration and durability. Machined, ductile spacer spools combined with 7 1/2", 9" or combination disc spacing maintain clearance and optimum pulverization.

Trust the Taylor-Way 351 to make your job easy, providing excellent discing strength in an implement made to last. Backed by many years of research and experience, you'll appreciate the craftsmanship at a price you can afford.



Optional

1" x 2" flexible steel hanger design to absorb shock load for increased bearing and axle life

Extra Equipment Available:

Gang Bolt Wrench
Furrow Filler Scraper

Equipment & Accessory Specifications

351 Series Item	Specification
Cutting Width Range	9' 3" to 16' 4"
Avg. Wt. Per Blade	128 lbs.
Narrow Frame Wheel Tread	100" Width
Wide Frame Wheel Tread	136" Width
Disc Spacing	7 1/2" or 9"
Blade Diameter	20" or 22"
Blade Thickness	6 or 7 Gauge
Transport Cylinder/Hoses	4" x 8" Double Acting Standard
Tongue Jack	3000 lbs. Standard

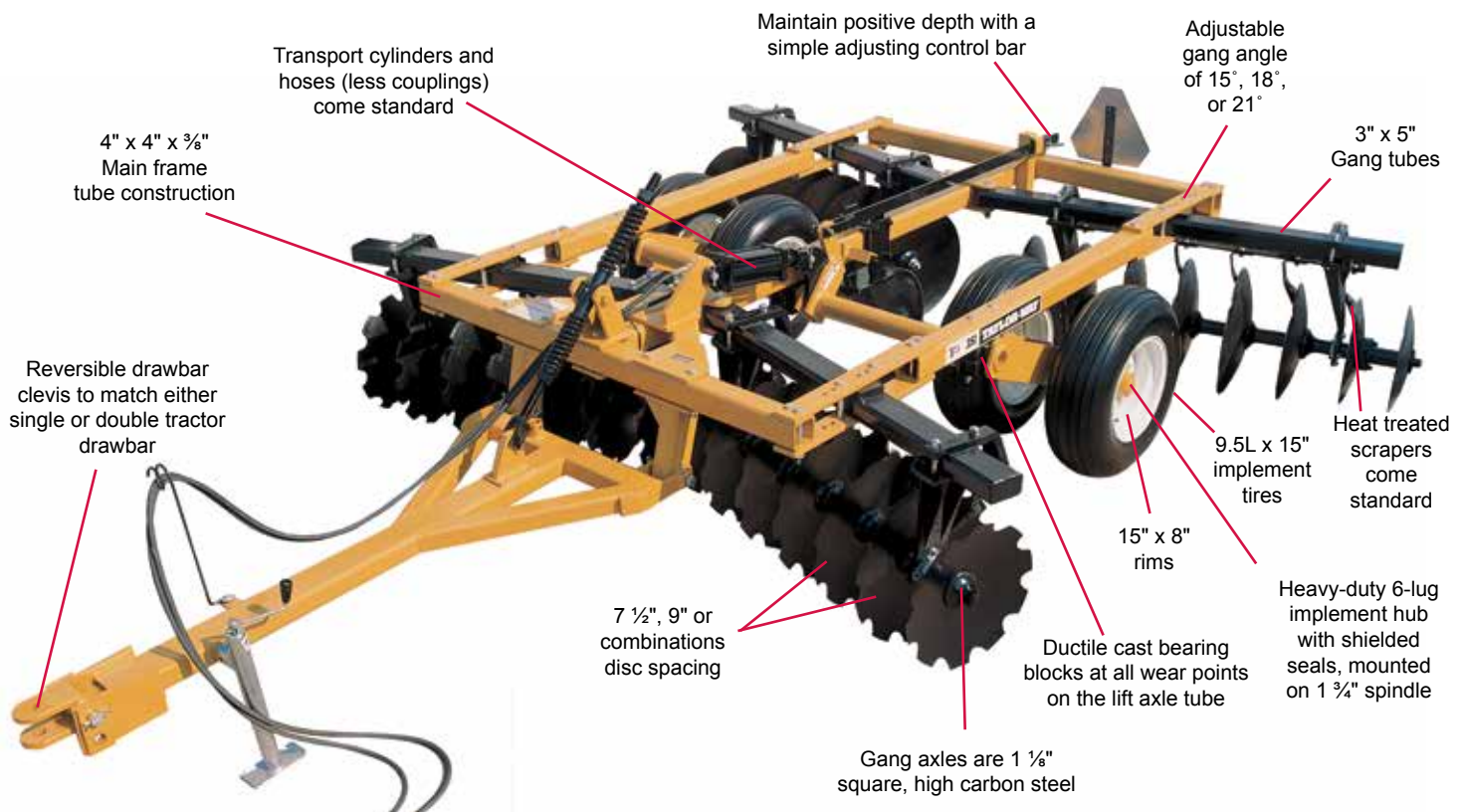

"DO IT THE TAYLOR-WAY"

Taylor Pittsburgh Mfg. • Athens, TN • (423) 745-3110

Narrow Frame – 20" Round Blades / Base Weight 7 ½" Disc Spacing

Cutting Width	Bearing Hanger Type	Number of Discs	Approx. Weight	Number of Bearings	Transport Wheels	Approx. DB HP
9' 3"	Rigid	28	3,932 lbs.	8	4	55 HP
9' 3"	Flex	28	4,029 lbs.	8	4	55 HP
10' 5"	Rigid	32	4,144 lbs.	8	4	60 HP
10' 5"	Flex	32	4,289 lbs.	8	4	60 HP
11' 6"	Rigid	36	4,356 lbs.	16	4	65 HP
11' 6"	Flex	36	4,550 lbs.	16	4	65 HP

Narrow Frame – 20" Round Blades / Base Weight 9" Disc Spacing

Cutting Width	Bearing Hanger Type	Number of Discs	Approx. Weight	Number of Bearings	Transport Wheels	Approx. DB HP
9' 4"	Rigid	24	3,842 lbs.	8	4	55 HP
9' 4"	Flex	24	3,940 lbs.	8	4	55 HP
10' 9"	Rigid	28	4,096 lbs.	8	4	60 HP
10' 9"	Flex	28	4,192 lbs.	8	4	60 HP
12' 2"	Rigid	32	4,350 lbs.	12	4	65 HP
12' 2"	Flex	32	4,495 lbs.	12	4	65 HP

Narrow Frame – 20" Round Blades / Base Weight 9" FT / 7 ½" RR Disc Spacing

Cutting Width	Bearing Hanger Type	Number of Discs	Approx. Weight	Number of Bearings	Transport Wheels	Approx. DB HP
9' 3"	Rigid	26	3,890 lbs.	8	4	55 HP
9' 3"	Flex	26	3,987 lbs.	8	4	55 HP
10' 5"	Rigid	30	4,120 lbs.	8	4	60 HP
10' 5"	Flex	30	4,217 lbs.	8	4	60 HP
11' 6"	Rigid	34	4,356 lbs.	12	4	65 HP
11' 6"	Flex	34	4,525 lbs.	12	4	65 HP

Wide Frame – 20" Round Blades / Base Weight 7 ½" Disc Spacing

Cutting Width	Bearing Hanger Type	Number of Discs	Approx. Weight	Number of Bearings	Transport Wheels	Approx. DB HP
12' 10"	Rigid	40	4,858 lbs.	16	4	70 HP
12' 10"	Flex	40	5,052 lbs.	16	4	70 HP
14' 0"	Rigid	44	5,112 lbs.	16	4	75 HP
14' 0"	Flex	44	5,306 lbs.	16	4	75 HP
15' 2"	Rigid	48	5,366 lbs.	16	4	80 HP
15' 2"	Flex	48	5,560 lbs.	16	4	80 HP
16' 4"	Rigid	52	5,620 lbs.	16	4	85 HP
16' 4"	Flex	52	5,814 lbs.	16	4	85 HP

Wide Frame – 20" Round Blades / Base Weight 9" Disc Spacing

Cutting Width	Bearing Hanger Type	Number of Discs	Approx. Weight	Number of Bearings	Transport Wheels	Approx. DB HP
13' 7"	Rigid	36	4,737 lbs.	16	4	70 HP
13' 7"	Flex	36	4,931 lbs.	16	4	70 HP
14' 10"	Rigid	40	4,997 lbs.	16	4	75 HP
14' 10"	Flex	40	5,191 lbs.	16	4	75 HP
16' 3"	Rigid	44	5,245 lbs.	16	4	80 HP
16' 3"	Flex	44	5,439 lbs.	16	4	80 HP

Wide Frame – 20" Round Blades / Base Weight 9" FT / 7 ½" RR Disc Spacing

Cutting Width	Bearing Hanger Type	Number of Discs	Approx. Weight	Number of Bearings	Transport Wheels	Approx. DB HP
14' 0"	Rigid	40	4,925 lbs.	16	4	75 HP
14' 0"	Flex	40	5,118 lbs.	16	4	75 HP
15' 2"	Rigid	44	5,185 lbs.	16	4	80 HP
15' 2"	Flex	44	5,378 lbs.	16	4	80 HP
16' 4"	Rigid	48	5,433 lbs.	16	4	85 HP
16' 4"	Flex	48	5,627 lbs.	16	4	85 HP

Series 580 Flex-Wing Tandem Disc Harrow

The Taylor-Way flex-wing design delivers excellent cutting and superior leveling ability resulting in a "Taylor Made" finish. When it comes to quality craftsmanship at a price you can afford there is no better choice than the Taylor-Way Series 580 Flex-Wing Tandem Disc Harrow. Trust the Taylor-Way Series 580 to make your job easy, providing excellent reliability in an implement made to last.



Standard
Ductile cast rigid bearing hanger with regreasable flanged type ball bearing.



Optional
1" x 2" flexible steel hanger design to absorb shock load for increased bearing and axle life.

Extra Equipment Available:

Gang Bolt Wrench
Furrow Filler Scraper

Equipment & Accessory Specifications

580 Series Item	Specification
Cutting Width Range	17' 5" to 25' 0"
Avg. Wt. Per Blade	134 lbs.
Transport Width	12' 9"
Disc Spacing	8", 9" or Combo
Blade Diameter	22"
Blade Thickness	6 Gauge
Transport Cylinder/Hoses	4" x 8"
Wing Cylinders	4" x 24"
Tongue Jack	5000 lbs. Standard

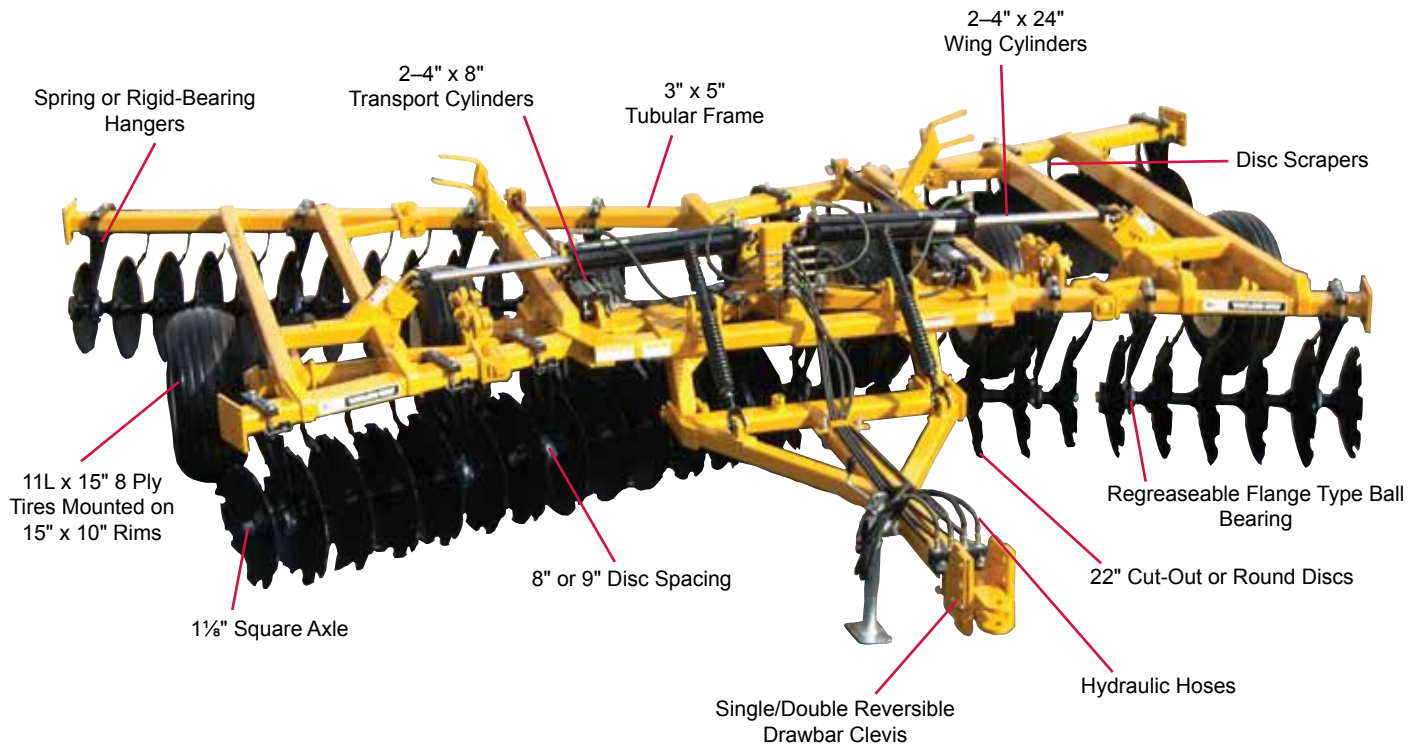

"DO IT THE TAYLOR-WAY"

Taylor Pittsburgh Mfg. • Athens, TN • (423) 745-3110

Narrow Frame – 22" Round Blades / Base Weight 8" Disc Spacing

Cutting Width	Bearing Hanger Type	Disc Spacing	Number of Discs	Approx. Weight	Number of Bearings	Transport Wheels	Wing Size	Approx. DB HP
17' 5"	Rigid	8"	52	7,458 lbs.	16	6	6F / 7R	100 HP
17' 5"	Flex	8"	52	7,718 lbs.	16	6	6F / 7R	100 HP
19' 11"	Rigid	8"	62	7,902 lbs.	24	6	8F / 10R	110 HP
19' 11"	Flex	8"	62	8,282 lbs.	24	6	8F / 10R	110 HP

Narrow Frame – 22" Round Blades / Base Weight 9" Disc Spacing

Cutting Width	Bearing Hanger Type	Disc Spacing	Number of Discs	Approx. Weight	Number of Bearings	Transport Wheels	Wing Size	Approx. DB HP
17' 11"	Rigid	9"	48	7,352 lbs.	16	6	6F / 7R	100 HP
17' 11"	Flex	9"	48	7,612 lbs.	16	6	6F / 7R	100 HP
20' 9"	Rigid	9"	56	7,702 lbs.	24	6	8F / 9R	110 HP
20' 9"	Flex	9"	56	8,082 lbs.	24	6	8F / 9R	110 HP

Narrow Frame – 22" Round Blades / Base Weight 9" FT / 8" RR Disc Spacing

Cutting Width	Bearing Hanger Type	Disc Spacing	Number of Discs	Approx. Weight	Number of Bearings	Transport Wheels	Wing Size	Approx. DB HP
17' 5"	Rigid	9" / 8"	52	7,406 lbs.	16	6	6F / 8R	100 HP
17' 5"	Flex	9" / 8"	52	7,626 lbs.	16	6	6F / 8R	100 HP
21' 2"	Rigid	9" / 8"	60	7,848 lbs.	24	6	8F / 10R	110 HP
21' 2"	Flex	9" / 8"	60	8,228 lbs.	24	6	8F / 10R	110 HP

Wide Frame – 22" Round Blades / Base Weight 8" Disc Spacing

Cutting Width	Bearing Hanger Type	Disc Spacing	Number of Discs	Approx. Weight	Number of Bearings	Transport Wheels	Wing Size	Approx. DB HP
22' 6"	Rigid	8"	70	8,504 lbs.	24	8	10F / 11R	125 HP
22' 6"	Flex	8"	70	8,884 lbs.	24	8	10F / 11R	125 HP
25' 0"	Rigid	8"	76	8,884 lbs.	24	8	12F / 13R	140 HP
25' 0"	Flex	8"	76	9,264 lbs.	24	8	12F / 13R	140 HP

Wide Frame – 22" Round Blades / Base Weight 9" Disc Spacing

Cutting Width	Bearing Hanger Type	Disc Spacing	Number of Discs	Approx. Weight	Number of Bearings	Transport Wheels	Wing Size	Approx. DB HP
22' 2"	Rigid	9"	60	8,292 lbs.	24	8	9F / 10R	125 HP
22' 2"	Flex	9"	60	8,672 lbs.	24	8	9F / 10R	125 HP
25' 0"	Rigid	9"	68	8,764 lbs.	24	8	11F / 12R	140 HP
25' 0"	Flex	9"	68	9,144 lbs.	24	8	11F / 12R	140 HP

Wide Frame – 22" Round Blades / Base Weight 9" FT / 8" RR Disc Spacing

Cutting Width	Bearing Hanger Type	Disc Spacing	Number of Discs	Approx. Weight	Number of Bearings	Transport Wheels	Wing Size	Approx. DB HP
22' 6"	Rigid	9" / 8"	64	8,398 lbs.	24	8	9F / 11R	125 HP
22' 6"	Flex	9" / 8"	64	8,778 lbs.	24	8	9F / 11R	125 HP
25' 0"	Rigid	9" / 8"	72	8,708 lbs.	24	8	11F / 13R	140 HP
25' 0"	Flex	9" / 8"	72	9,088 lbs.	24	8	11F / 13R	140 HP



Series 870/875 Cultivator Incorporator

Do you want to have the field that all the neighbors are talking about? Then you need to get a Taylor-Way Series 870 or 875 Cultivator Incorporator. Available in a rigid frame (870 Series) or Hydraulic wing fold (875 Series) we have a size to fit your need at a price you can afford.

Our Cat. II – III, 3-point hitch Cultivator Incorporators feature a strong tubular frame (2"x2"x $\frac{3}{16}$ "") to which we mount the ultra high vibrating tines that fully incorporate chemicals and fertilizer into the soil. The tines are followed by our double roller baskets that create a superior seedbed that's ready for planting.

Trust that the Taylor-Way 870/875 has been built to last and provide you with superior field finishing at an economical price.

STANDARD FEATURES

- Adjustable Pin Type Gauge Wheels (Rigid Frame)
- Adjustable Turnbuckle Type Gauge Wheels (Hydraulic Fold Frame)
- Double Roller Baskets with Greasable Ball Bearings
- Heavy Duty Cat. II – III, 3-point hitch
- Optional Rims Only or Tires Mounted on Rims
- Ultra-High Vibration Tines
- Welded Tubular Frame
- Floating Wings Designed to Follow the Contour of the Ground (Hydraulic Fold)
- Aggressive Flat Bar Basket Design to Maximize Clod Breakage
- Springs Allow Down Pressure on Rolling Baskets to be Adjusted to Field Conditions

Extra Equipment Available:

Reversible Points & Sweeps
1" Reversible Point
2 1/2" Sweep
4" Sweep

Series 870/875 Cultivator Incorporator

Model # Number	Working Width	Number of Tines	Rolling Baskets	Frame Type	Min. H.P. At Drawbar	Approx. Weight
870-10-31	10' 4"	31	2-40" & 1-60"	Rigid	60	1,992 lbs.
870-12-37	12' 4"	37	1-40" & 2-60"	Rigid	75	2,187 lbs.
870-14-43	14' 4"	43	3-60"	Rigid	85	2,322 lbs.
870-19-57	19'	57	4-60"	Rigid	115	3,082 lbs.
875-19-57	19'	53	4-60"	HYD Fold	120	3,942 lbs.
875-22-67	22'	63	4-40" & 2-60"	HYD Fold	145	4,682 lbs.



*Shown with optional 1" reversible point

“DO IT THE TAYLOR-WAY”

Taylor Pittsburgh Mfg. • Athens, TN • (423) 745-3110

Series 233 Arena Renovator / Cultipacker

The Arena Renovator is the only fully adjustable Arena Renovator on the market today that does not require tools for adjustment. Through the use of adjustable links and pins, it is easily adjusted to fit your specific application. Fifteen high vibration tines and adjustable smoother bar and crumbling basket make this the tool you need for preparing your riding arena.

Model	233-AR-72
Width	72"
Tine Type	Danish Tine
Tine Material	Spring Steel
No. of Tines	15
Tine Points	Reversible Heat Treated
Smoother Bar	Reversible, Replaceable
Crumbling Basket	Flat Bar, Spiral Configuration
Smoother Bar Adjustment	Adjustable Link & Pins
Crumbling Basket Adjustment	Adjustable Link
Tools Needed for Adjustment	None
Hitch	Cat. I & II Straddle
Frame	Square & Rectangle Tube
HP Range	55 - 80 HP
Approx. Ship Wt.	752 lbs.



233-AR-72

Arena Renovator

STANDARD FEATURES

- Cat. I & II, 3-Point Hitch
- 15 High Vibration Tines
- Fully Adjustable without the use of Tools
- Adjustable Smoother Bar
- Adjustable Crumbling Basket

Cultipacker

Model	233-KP-72-L
Width	72"
Approx. Ship Wt.	508 lbs.
HP Range	35 - 60 HP
Hitch	Cat. I Quick Hitch Compatible

Taylor Pittsburgh's 3-pt Cultipacker is the ideal tool for pressing grass, clover, or alfalfa seed into the seedbed, to produce optimal soil-to-seed contact and achieve a desirable stand. It can also be used to break up dirt clods prior to planting, seeding, or fertilizing. The Cat I, 3-pt quick hitch compatible hitch, integrated parking stands, and built-in weight box make this a great tool for any homeowner or landscape professional.



233-KP-L

Quick Hitch
Compatible



Series 233 and 1100 Tillage Equipment

Taylor Pittsburgh's Single Row "C" Tine Cultivator is the perfect cultivation tool for the small farm or backyard garden. It features high quality spring steel "C" tines, reversible heat-treated points, row width adjustments, attached to a high ground clearance heavy angle iron frame.

STANDARD FEATURES

- Heavy Duty, Angle Frame
- Adjustable Row Widths
- Reversible, Heat Treated Points
- Cat. I, Quick Hitchable, 3-Point Hitch



"C" Tine Cultivator



Model	Approx. Ship Wt.	HP Range
233-CV-G-1-C	122 lbs.	20 - 40 HP

Field Cultivator

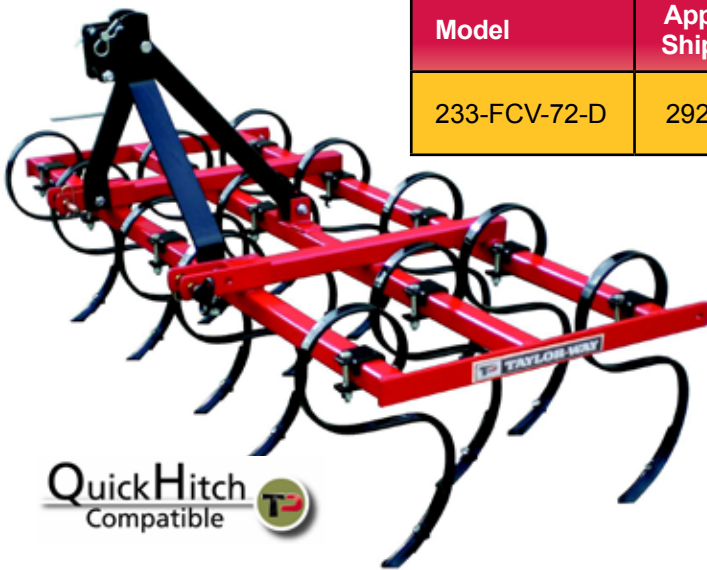

Model	Approx. Ship Wt.	HP Range
233-FCV-72-D	292 lbs.	25 - 50 HP

Taylor Pittsburgh's Field Cultivator performs a multitude of in-field tasks including seedbed preparation, soil aeration, weed abatement, and the uniform incorporation of chemicals and fertilizers in the soil.

STANDARD FEATURES

- 13 Shank, High Vibration, Danish S-Tines with Reversible Points
- Accommodates Cat. I Quick Hitch
- Heavy Duty Frame Made of Three 2" Square Tubes
- 72" Working Width
- Tines Set Up on 6" Centers - Can be Adjusted



The 233 Series Disc Bedder allows adjustment of the discs to virtually any row width up to 48". The 48" square tube toolbar allows the bedder shanks to slide for widening or narrowing the bed. This Disc Bedder features a Cat. I quick hitchable, 3-point hitch and is ideal for home gardeners, vegetable growers and farmers.

STANDARD FEATURES

- Cat. I, Quick Hitchable, 3-Point Hitch
- Sealed Bearings
- 16" Adjustable Shanks
- Tubular Steel Frame
- 14" Disc Blades with Adjustable Angle and Width

233 Series Disc Bedder



Model	Approx. Ship Wt.	Working Width	HP Range
233-DB	110 lbs.	Up to 48"	20 - 40 HP

"DO IT THE TAYLOR-WAY"

Taylor Pittsburgh Mfg. • Athens, TN • (423) 745-3110

Middle Buster

Taylor Pittsburgh's Middle Buster combines strength and durability to offer a tool with many uses. Its solid shank and heavy duty frame construction make a solid platform for the 14" furrower to do its job. The middle buster is great for laying off rows, digging potatoes, pointing a ditch, general field preparation and many other farm, field, and garden uses.

STANDARD FEATURES

- Solid Steel Shank
- Forged Lift Pins
- Heavy Duty Steel Frame
- 14" Heat Treated Furrower

Model	Approx. Ship Wt.	Hitch Category	HP Range
233-MB	90 lbs.	CAT. I	17 - 40 HP



Sub-Soiler

Taylor Pittsburgh's Sub-Soiler is the tool you need for ripping sod and loosening compacted soil for better plant growth and production. It features a heavy frame, a solid steel beam backbone, and a forged, heat treated reversible ripper tooth, capable of a 14" maximum ripping depth.

STANDARD FEATURES

- Solid Steel Shank
- Forged Lift Pins
- Heavy-Duty Steel Frame
- Heat Treated Reversible Ripper Tooth

Model	Approx. Ship Wt.	Hitch Category	Ripping Depth	HP Range
233-SUB	101 lbs.	CAT. I	14"	17 - 40 HP



Heavy Duty Sub-Soiler

STANDARD FEATURES

- 1" x 8" Replaceable Ripper Tooth
- 50 1/2" Over All Height
- For Tractors Up to 85 HP 2 Wheel Drive / 70 HP 4 Wheel Drive
- Integrated Storage Stand for Easy Hook Up to Tractor

Model	Approx. Ship Wt.	Hitch Category	Ripping Depth	Max. HP
1100-SUB	285 lbs.	CAT. I / CAT. II	24"	85 HP @ 2 wheel drive 70 HP @ 4 wheel drive



Series 3100 / 233 Heavy Duty Estate Groomer

Whether your grooming job is a simple estate or you need real cutting power in a commercial setting, Taylor-Way has a Heavy Duty Estate Groomer to fit your needs.

Each Groomer has been designed for commercial grade performance, better cutting quality with minimum power required, and most importantly... easy maintenance. Our development team has put several years of experience into making Taylor-Way Groomers the number one choice in the industry.

Available in three sizes, these Groomers can mow small or large areas with minimal time and effort. Multiple height settings and optional anti-scalp rollers provide a professional cut finish even on rough terrain while the high blade tip speeds and under-deck baffling maintain excellent distribution of clippings.

The Estate Groomers have accessible settings, parts and grease fittings for the ultimate in ease and cutting results. The 233 Series 7' finish mower features a patented Free Floating Flex Hitch along with a $\frac{3}{16}$ " thick stainless steel reinforced deck.



Series 3100

Model	3100-60	3100-72	233-RSFM-SS-84-FH
Cutting Width	60"	72"	84"
Number of Blades/Spindles	3	3	3
Hitch	Cat I, Full floating	Cat I, Full floating	Cat. I, Free Floating Flex
Cutting Height Range	1 - 5"	1 - 5"	1 - 4 ½"
Approx. Weight	565	610	645
Deck Thickness	7 gauge	7 gauge	$\frac{3}{16}$ " Stainless Steel
Blade Spindles	Tapered roller bearing	Tapered roller bearing	Greaseable Ball Bearing
Drive Belt	Single, heavy-duty Kevlar™	Single, heavy-duty Kevlar™	Double V Belt
Belt Adjustment	Automatic Spring Tensioner	Automatic Spring Tensioner	Automatic Spring Tensioner
Caster Wheels	4, solid or pneumatic tires	4, solid or pneumatic tires	4 solid tires
Recommended PTO HP	15-35	20-40	25-40

Series 233



QuickHitch Compatible 



"DO IT THE TAYLOR-WAY"
Taylor Pittsburgh Mfg. • Athens, TN • (423) 745-3110

Series 233 Flex Hitch Domed Deck Rotary Cutter

The Patented Series 233 Flex Hitch Rotary Cutter demonstrates the latest in rotary cutter innovation. The Cat. 1 quick hitchable, flex hitch design, is unlike anything on the market today. The hitch allows the rotary cutter to move 15° up or down on the left or right side of the machine to follow the contours of the field. The domed deck design sheds water and debris to prevent material from collecting on the deck, virtually preventing the deck from rusting.

Flex Hitch Domed Deck Rotary Cutter

Model	233-L-48-40-PFH / 233-L-48-40-SC-FH	233-L-60-40-PFH / 233-L-60-40-SC-FH	233-L-72-40-PFH / 233-L-72-40-SC-FH / 233-L-72-60-SC-FH	233-L-60-40-SSFH
Working Width	48"	60"	72"	60"
Gearbox Rating	40 HP / 40 HP	40 HP / 40 HP	40 HP / 40 HP / 60 HP	40 HP
Blades	½" x 3"	½" x 3"	½" x 3"	½" x 3"
Stump Jumper	Round	Round	Round	Round
Cutting Height Range	2" to 10"	2" to 10"	2" to 10"	2" to 10"
Gear Box Protection	SB / SC	SB / SC	SB / SC / SC	SC
Deck Material	12 ga	12 ga	12 ga	12 ga Stainless Steel
Side Skirt Material	" I " Beam	" I " Beam	" I " Beam	10 ga Stainless Steel
Tailwheel	Laminated	Laminated	Laminated	Laminated
Hitch	Cat. 1 Quick Hitchable	Cat. 1 Quick Hitchable	Cat. 1 Quick Hitchable	Cat. 1 Quick Hitchable
Chain Guards	Optional	Optional	Optional	Standard
Approx. Weight	470 lbs. / 497 lbs.	557 lbs. / 584 lbs.	664 lbs. / 691 lbs. / 712 lbs.	565 lbs.
Minimum PTO HP	15 HP / 15 HP	20 HP / 20 HP	30 HP / 30 HP / 35 HP	20 HP
Cutting Capacity	Up to 1"	Up to 1"	Up to 1"	Up to 1"



Quick Hitch
Compatible 

Series 240/360/480 Round Back Rotary Cutter

240 SERIES ROUND BACK ROTARY CUTTERS are constructed using 11 gauge for the top sheet and 10 gauge on the side skirts for added strength. They come equipped with your choice of a 50 HP shear bolt or slip clutch gearbox. Available in 5' and 6' widths with Cat. I hitches. This is a quality manufactured cutter that can be purchased for an affordable price.

STANDARD FEATURES

Cat. I Hitch
11 Gauge Top Deck Thickness
10 Gauge Side Skirt Thickness
50 HP Gearbox
Available in 5' and 6' widths

Extra Equipment Available:

Front Chain Guards
Front Deflector Shields
Slip Clutch



360 SERIES ROUND BACK ROTARY CUTTERS feature a 60 HP slip clutch protected gearbox. They are constructed with a 10 gauge top deck and 7 gauge side skirt material for added strength and durability. Available in 5' and 6' cutting widths both with a Cat. I hitch. If you want a cutter that will perform and last, this is the cutter you have been looking for.

STANDARD FEATURES

Cat. I Hitch
10 Gauge Top Deck Thickness
7 Gauge Side Skirt Thickness
60 HP Gearbox
Slip Clutch Protected
Available in 5' and 6' widths
Chain Guards Standard



"DO IT THE TAYLOR-WAY"

Taylor Pittsburgh Mfg. • Athens, TN • (423) 745-3110

480 SERIES ROUND BACK ROTARY CUTTERS are designed with the tough cutting jobs in mind. Manufactured with 7 gauge top deck and ¼" side skirt material for added strength. They come equipped with a 90 HP slip clutch protected gearbox designed to run at 540 RPM. Designed to mount on tractors with either Cat. II or Cat. III hitches and available in 6' and 7' cutting widths. (6' Cat. II only)



STANDARD FEATURES

- Cat. II or III Hitch
- 7 Gauge Top Deck Thickness
- ¼" Gauge Side Skirt Thickness
- 90 HP Gearbox
- Slip Clutch Protected
- Available in *6', and 7' Widths
- *6' Cutter - Single Tailwheel Only
- Chain Guards Standard

Round Back Rotary Cutters

Model	245	246	365	366	486	487
Cutting Width	60"	72"	60"	72"	72"	84"
Gearbox Rating	50 HP	50 HP	60 HP	60 HP	90 HP	90 HP
PTO RPM	540	540	540	540	540	540
Blades	½" x 3"	½" x 3"	½" x 3"	½" x 3"	½" x 4"	½" x 4"
Stump Jumper	Round	Round	Round	Round	Round	Round
Cutting Height Range	2" to 10"	2" to 10"	2" to 12"	2" to 12"	2" to 12"	2" to 12"
Gear Box Protection	SB or SC	SB or SC	SC	SC	SC	SC
Deck Material	11ga	11ga	10ga	10ga	7ga	7ga
Side Skirt Material	10ga	10ga	7ga	7ga	¼"	¼"
Side Skirt Depth	7"	7"	8"	8"	9"	10"
Tailwheel(s)	Single Laminated	Single Laminated	Single Laminated	Single Laminated	Single Laminated	Dual Laminated
Hitch	Cat. I	Cat. I	Cat. I	Cat. I	Cat. II	Cat. II or III
Deflector Shields	Optional	Optional	Not Available	Not Available	Not Available	Not Available
Chain Guards	Optional	Optional	Standard	Standard	Standard	Standard
Approx. Weight	606 lbs.	683 lbs.	765 lbs.	860 lbs.	1163 lbs.	1630 lbs.
Cutting Capacity	Up to 1"	Up to 1"	Up to 1.5"	Up to 1.5"	Up to 2"	Up to 2"
Minimum PTO HP	20 HP	30 HP	30 HP	35 HP	50 HP	60 HP

Series 233 7' / 10' Lift Type Rotary Cutter

The Series 233 7' / 10' Rotary Cutters are quality built durable cutters constructed with a heavy duty single sheet top deck with cross bracing. Standard features include cast iron gearboxes, stump jumpers, adjustable laminated tail wheels and a shielded PTO with slip clutch.

233 Series 7' Rotary Cutter



233 Series 10' Rotary Cutter

Model	233-84-SC-CG	233-120-SC-CG
Size	7'	10'
Gear Box HP	75 HP	Outboard 75 HP, Center 100 HP
PTO RPM	540	540
Blades	3/8" x 4" Heat Treated	3/8" x 4" Heat Treated
Stump Jumper	Round	Round
Cutting Height Range	2" to 10"	2" to 10"
Gear Box Protection	Slip Clutch	Slip Clutch
Deck Thickness	10 Ga.	10 Ga.
Side Skirt Depth	8 1/2"	8"
Tailwheel(s)	Laminated	Laminated
Hitch	Cat. II	Cat. II
Drive Line	Cat. 4	Cat. 6
Chain Guards	Standard	Standard
Approx. Weight	950 lbs.	1540 lbs.
Minimum PTO Required	55 HP	65 HP
Cutting Capacity	Up to 1"	Up to 1"

"DO IT THE TAYLOR-WAY"

Taylor Pittsburgh Mfg. • Athens, TN • (423) 745-3110

Series 270 10' Pull and Lift Type Cutter

The Series 270 10' Pull-type and Lift-type Cutters deliver powerful cutting action, and a variety of options that make it easy to customize your implement for a wide range of uses. Designed for tough cutting jobs, our mowers will provide you with years of dependable service.

STANDARD FEATURES

- 7 Gauge Deck Material
- 10" x 1/4" Side Skirts
- 90 HP Outboard Gearboxes, and 125 HP Splitter Gearbox, 540 RPM
- Replaceable Skid Shoes
- Tubular (2" x 3") Bracing

Round Back Rotary Cutters

	Specifications
Cutting Width	120"
Gearbox	Outboard 90 hp 125 Splitter
PTO Requirement	540
Skirt Depth / Material	7 Gauge (3/16")
Deck Reinforcement	2" x 3" Square Tube
Blades	1/2" - 4"
Stump Jumper	20" Diameter Round
Cutting Height Range	1 1/2" - 12"
Cutting Capacity	Up to 2"
Tailwheel Type	Laminated or Used Airplane
Number of Tailwheels	Single (2) Double (4)
Hitch	Cat. II or III Quick Hitch or Pull-Type
Safety Shields	Chain Guarding Standard
PTO/HP Requirements	50 - 80 HP
Weight	2,724 lbs. - With Chains and 2 Laminated Tires
Overall Width	123 1/2" Outside Frame 124 1/2" at Skidshoes
Overall Length	Pull - 13 1/2' Lift - 9 1/2'

C.V. Driveline Standard
(pull type only)



Series 1510 / 1550 Flex-Wing Rotary Cutter

Tough cutting applications are no match for Taylor Pittsburgh's 1510/1550 15' Flex-Wing Rotary Cutter. Try the industry's best choice for maximum power and maneuverable cutting ability.

Four Gearbox Design with a Main Splitter Gearbox and Three Independent Drive Gearboxes

Rugged 7 Gauge Deck

Spring Cushioned Wheel Axles

Dual Center Section Wheels

Round Stump Jumpers

Constant Velocity Input PTO - Cat. 8 CV 540, Cat.6 CV 1000

Cat. 6 Wing Drivelines

Slip Clutches on all Drive Gearboxes

Replaceable Center Section and Wing Skid Shoes

Heavy-duty Castering Straddle Type Hitch Clevis

Self-leveling Tongue w/Dual Leveling Rods

Heavy-duty Tongue Jack with Storage Location on the Deck

Your Choice of Tires:

21" Laminated Tires

Heavy Ply Used Airplane Tires

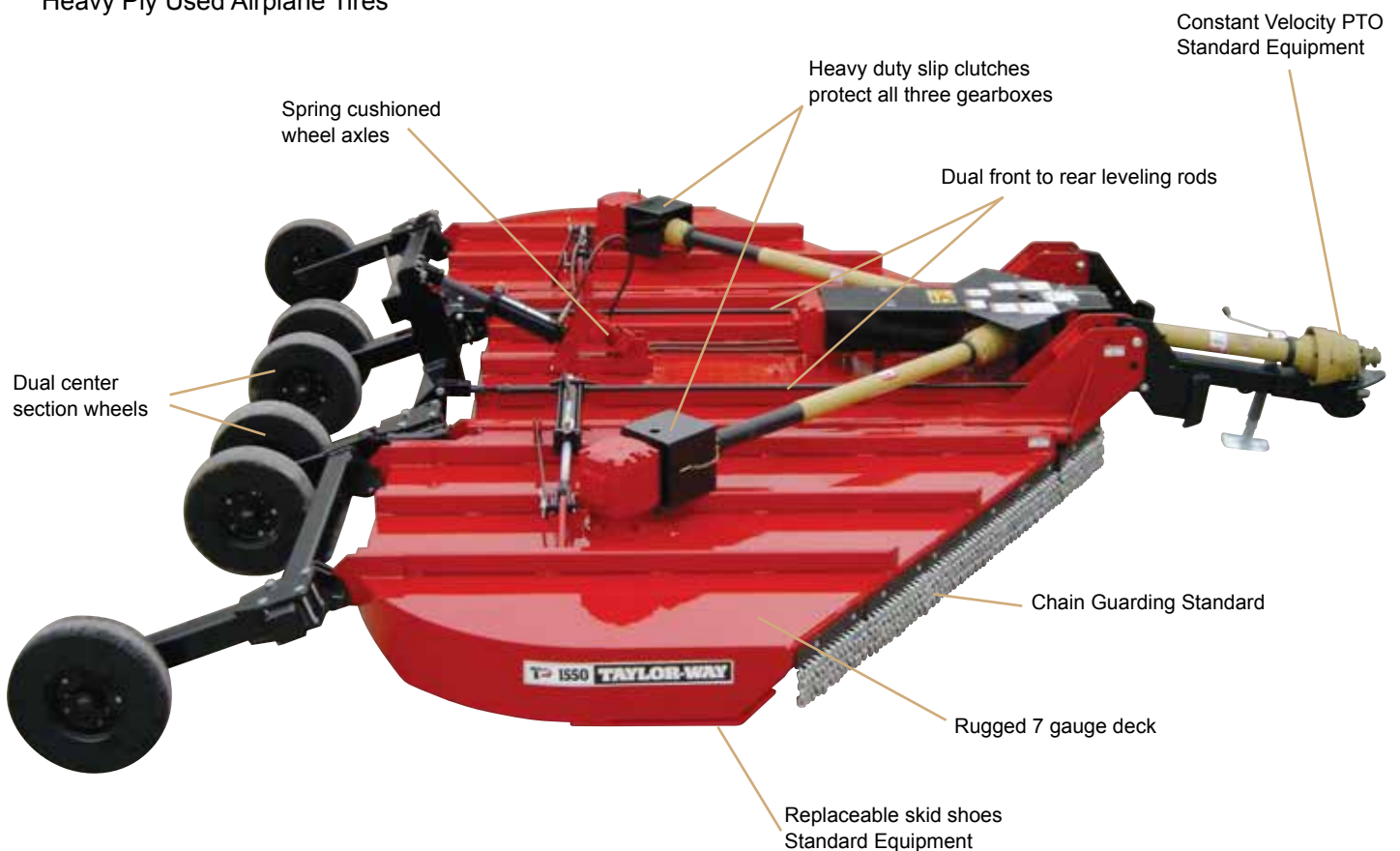

"DO IT THE TAYLOR-WAY"

Taylor Pittsburgh Mfg. • Athens, TN • (423) 745-3110

SERIES 1510 / 1550	SPECIFICATIONS
Gearbox Horsepower Ratings	540 RPM Splitter: 170 HP 1000 RPM Splitter: 240 HP 540 RPM Drive: 3 x 150 HP 1000 RPM Drive: 3 x 220 HP
Blade Tip Speed	15,000 RPM
Blades	½" x 4" High Lift
Hydraulic Cylinders	Wing: 3" x 12" Standard Transport: 3" x 8" Standard
Drivelines	Input: Cat. 8 CV 540, Cat.6 CV 1000 Wing: Cat. 6 Standard Slip Clutches: Standard
Deck Depth	10"
Side Skirt Construction	¼" Thickness
Cutting Height	1" - 15"
Cutting Capacity	Brush up to 2"
Blade Overlap	5 ½"
Wing Fold Angle	90° Up, 22° Down
Recommended Minimum Tractor HP	65 HP
Approximate Machine Weight	4815 lbs. with Chains

Standard Features	Wheel Options
Parking Stand Wing Lift Cylinders Skid Shoes CV Driveline Cat. 8, 540 RPM CV Driveline Cat. 6, 1000 RPM Dual Center Section Wheels Front & Rear Chain Guards	Laminated, Used Airplane

Series 233 / 4500 Rear Blades

Taylor Pittsburgh's 233 Series Rear Blades are designed for value added performance. Uses include road grading and maintenance, landscaping, snow removal, cleaning livestock pens and much more. Each moldboard is equipped with a high carbon steel reversible cutting edge that adds to the life of the blade.

233-RB-G



233 RB Series Rear Blade

The 233 RB Series Rear Blades feature a specially formed, 14" high, 1/4" thick moldboard designed to roll dirt or snow and prevent drag. Each moldboard is equipped with a high carbon steel reversible cutting edge that adds to the life of the blade. They have 5 forward and 5 reverse angle settings.



233-PRB

233 PRB Series Rear Blades

The 233 PRB Series Rear Blades feature a specially formed moldboard, with reinforced back bracing for extra strength and performance. They have 7 forward and 5 reverse angle settings plus they will tilt and offset left or right. The high carbon steel cutting edge is reversible.

Model	Width	Approx. Ship Wt.	Angle Adjustments	Tilt	Offset	Parking Stand	HP Range
233-RB-G-60	60"	221 lbs.	5 Front & 5 Rear	no	no	no	17 - 35 HP
233-RB-G-72	72"	242 lbs.	5 Front & 5 Rear	no	no	no	17 - 35 HP
233-RB-G-84	84"	260 lbs.	5 Front & 5 Rear	no	no	no	17 - 35 HP
233-PRB-72	72"	330 lbs.	7 Front & 5 Rear	yes	yes	no	25 - 45 HP
233-PRB-84	84"	359 lbs.	7 Front & 5 Rear	yes	yes	no	25 - 45 HP
233-PRB-96	96"	386 lbs.	7 Front & 5 Rear	yes	yes	no	25 - 45 HP
233-RB-84-QAT	84"	389 lbs.	5 Front & 5 Rear	yes	no	yes	25 - 45 HP
233-HD-RB-72	72"	569 lbs.	5 Front & 5 Rear	yes	no	yes	40 - 70 HP
233-HD-RB-84	84"	611 lbs.	5 Front & 5 Rear	yes	no	yes	40 - 70 HP
233-HD-RB-96	96"	636 lbs.	5 Front & 5 Rear	yes	no	yes	40 - 70 HP

"DO IT THE TAYLOR-WAY"

Taylor Pittsburgh Mfg. • Athens, TN • (423) 745-3110

233-RB-QAT Series Rear Blades

The 233-RB-QAT Series Rear Blades have moldboards with an easy to adjust lever for tilt and angle. They have 5 forward and 5 reverse angle settings. They have formed moldboards with bracing, a high carbon steel reversible, replaceable cutting edge and a patented kick stand.



233-RB-QAT

QuickHitch
Compatible 

233-HD-RB Series Rear Blades

The 233-HD-RB Series Rear Blades feature a specially formed moldboard reinforced with gussets for added strength and performance. Each moldboard is equipped with a high carbon steel reversible cutting edge. They also have easy adjust latch assemblies for the angle and tilt adjustment, and a patented kick stand.



233-HD-RB

4500-RB



QuickHitch
Compatible 

4500 Series Rear Blade

The 4500 Series Rear Blades offer features for most landscaping, grading and snow removal applications. The blade is 6 way adjustable allowing the user to Tilt, Angle, and Offset the blade at the same time to achieve the desired results. The moldboard is a full 1/4' thick with a heat treated double beveled reversible 1/2" x 6" cutting edge. The pivot pin has a bushing that is a full 2-1/8" in diameter and the blade comes with a kick stand.

Model	Width	Approx. Ship Wt.	Angle Adjustments	Tilt	Offset	Parking Stand	HP Range
4500-RB-60	60"	293 lbs.	5 Front & 5 Rear	yes	yes	yes	20 - 35 HP
4500-RB-72	72"	313 lbs.	5 Front & 5 Rear	yes	yes	yes	20 - 35 HP
4500-RB-84	84"	342 lbs.	5 Front & 5 Rear	yes	yes	yes	30 - 45 HP
4500-RB-96	96"	370 lbs.	5 Front & 5 Rear	yes	yes	yes	30 - 45 HP

Series 5500 / 8500 Rear Blades

5500 Series Rear Blades

Taylor Pittsburgh 5500 Series Rear Blades are constructed with a heavy 4" x 4" x 3/8" main tube, straddle type combination 3-point hitch, and manual angle, offset and tilt functions. The 5500 has a reversible cutting edge, a reversible curved moldboard and comes in 3 working widths.



QuickHitch
Compatible 

8500 Series Rear Blades

Taylor Pittsburgh 8500 Series Heavy Duty Rear Blades gives you the added features that make any heavy duty job easier than ever. Fully adjustable with mechanical or hydraulic adjustments on angle, offset and tilt functions. Constructed for strength with a heavy 4" x 4" x 3/8" main tube, straddle type combination 3-point hitch and you have a choice of optional end plates and skid shoes. The 8500 has a reversible cutting edge, a reversible curved moldboard and comes in 7' or 8' working widths. These rear blades are an excellent choice for leveling, ditching, landscaping, road maintenance, snow removal and more.



QuickHitch
Compatible 

Series	5500	8500
Operating Width	6' / 7' / 8'	7' / 8'
Horsepower Rating	55 HP @2wd / 45 HP @4wd	85 HP @2wd / 75 HP @ 4wd
Hitch Type	Cat. I & Cat. II Straddle Type	Cat. I & Cat. II Straddle Type
Moldboard	5/16" x 15 1/4"	5/16" x 18"
Cutting Edge	1/2" x 6" Reversible	1/2" x 6" Reversible
Angle Adjustment	0°-15°-30°-45° Forward 0°-15°-30° Reverse	Up to 36° Left or Right (Forward Or Reverse)
Tilt Adjustment	0°-15°-30° Up or Down	Maximum 24° Up and 28° Down
Offset Adjustment	0"-7 5/16"-14 1/4"-20 1/2" Left or Right	0" to 28 3/4" Left or Right
Approx. Weight	485lbs. / 510lbs. / 535lbs.	793lbs. / 825lbs.
Adjustment Types	Manual	Mechanical, Hydraulic or Combination
Optional Moldboard End Plates	No	Yes
Optional Skid Shoes	No	Yes
Parking Stand	Yes	Yes

"DO IT THE TAYLOR-WAY"

Taylor Pittsburgh Mfg. • Athens, TN • (423) 745-3110

Series 233 / 4500 Landscape Rake

233-YR-G



QuickHitch
Compatible 

233 Series Landscape Rake

Taylor Pittsburgh's 233 Series Landscape Rakes are engineered for versatility by having 5 forward and 5 reverse angle settings. The 233 Series Landscape Rake features a uniquely designed, adjustable stabilizer bar that allows the $\frac{5}{16}$ " x 1" heat treated spring steel tines to be more or less rigid by raising or lowering the stabilizer bar.

You will find both these Landscape Rakes handy tools for spreading topsoil, distributing gravel, removing stones and debris, preparing for seeding and general grading work.

4500 Series Landscape Rakes

Taylor Pittsburgh's 4500 Series Landscape Rakes have 7 forward and 5 reverse angle settings. The 4500 Series Landscape Rake also features $\frac{5}{16}$ " x 1" high carbon spring steel teeth on 2" centers and comes complete with parking stand.



4500-LSR

QuickHitch
Compatible 

Model	Width	Approx. Ship Wt.	HP Range	Hitch	Options
233-YR-60-G	60"	223 lbs.	17-50 HP	Cat. I Quick Hitch Compatible	Guage Wheels
233-YR-72-G	72"	239 lbs.	17-50 HP	Cat. I Quick Hitch Compatible	Guage Wheels
233-YR-84-G	84"	265 lbs.	23-50 HP	Cat. I Quick Hitch Compatible	Guage Wheels
233-YR-96-G	96"	290 lbs.	23-50 HP	Cat. I Quick Hitch Compatible	Guage Wheels
4500-LSR-72	72"	341 lbs.	20-50 HP	Cat. I Quick Hitch Compatible	Guage Wheels
4500-LSR-84	84"	373 lbs.	25-50 HP	Cat. I Quick Hitch Compatible	Guage Wheels
4500-LSR-96	96"	405 lbs.	25-50 HP	Cat. I Quick Hitch Compatible	Guage Wheels

Series 233 / 4500 Landscape Equipment

Reversible Dirt Scoop

Taylor Pittsburgh's Reversible Dirt Scoop features a uniquely designed heavy duty angle iron frame. The reversible mounting allows you to attach your tractor to the front or rear of the scoop, enabling it to work forward as a slip scraper or in reverse as a shovel. The cutting edge is beveled.



Model	Width	Approx. Ship Wt.	HP Range	Hitch	Options
233-DS-30	30"	269 lbs.	17 - 40 HP	Cat. I Front and Rear	None

233-DS



233-DEG

Dual Edge Land Graders

Taylor Pittsburgh's Dual Edge Land graders are the perfect tool for the driveway and gravel road maintenance and construction. They fill potholes and low spots to redistribute material to achieve the perfect roadway surface. The heavy duty frame is built with 3" x 3" tubing and the cutting edges are reversible. The 1/2" wear pads are replaceable.



Model	Width	Approx. Ship Wt.	HP Range	Hitch	Options
233-DEG-60	60"	447 lbs.	35 - 60 HP	Cat. I Quick Hitch Compatible	None
233-DEG-72	72"	491 lbs.	35 - 60 HP	Cat. I Quick Hitch Compatible	None
233-DEG-84	84"	540 lbs.	35 - 60 HP	Cat. I Quick Hitch Compatible	None



233-BB-G

233 Series Box Blades

Taylor Pittsburgh's 233 Series Box Blades are designed for rugged use by homeowners, landscapers, and farmers. You will find these box blades are great for landscaping, land leveling, backfilling, grading and many other applications. These box blades feature a heavy, all welded A-frame and is CAT. I quick hitch compatible, along with a 20" self-cleaning moldboard attached to 1/2" x 6" reversible cutting edges. The shank beam is 4" x 4" and holds heat treated shanks with replaceable points.

"DO IT THE TAYLOR-WAY"

Taylor Pittsburgh Mfg. • Athens, TN • (423) 745-3110

233 Series Hinged Back Box Blades

The 233 Hinged Back Box Blade has the same features as the standard box blade. In addition the rear cutting edge is hinged to allow deeper penetration and to eliminate the buildup of soil between the cutting edges. The end plates are $\frac{5}{8}$ " and the bracing front to back is $\frac{1}{2}$ ".



233-H-BB

QuickHitch
Compatible 

QuickHitch
Compatible 



4500-BB

4500 Series Box Blades

The 4500 Series Box Blade is designed for grading and leveling jobs. The heavy duty upper frame, 17" 7 gauge formed moldboard, two $\frac{1}{2}$ " x 6" heat treated reversible cutting edges, $\frac{5}{8}$ " end plates with wear strip, and reinforced scarifier bar all add up to a box blade that is built to work. The Cat. I, 3-point straddle hitch is also Quick Hitch Compatible. They are recommended for tractors up to 50 HP.

Model	Width	Approx. Ship Wt.	Number of Shanks	HP Range
233-BB-G-48	48"	384 lbs.	4	20 - 30 HP
233-BB-G-60	60"	447 lbs.	5	25 - 35 HP
233-BB-G-66	66"	479 lbs.	5	25 - 35 HP
233-BB-G-72	72"	510 lbs.	6	30 - 45 HP
233-BB-G-84	84"	573 lbs.	6	30 - 50 HP
233-H-BB-60	60"	502 lbs.	5	25 - 35 HP
233-H-BB-72	72"	565 lbs.	6	30 - 45 HP
233-H-BB-84	84"	622 lbs.	6	30 - 50 HP
233-H-BB-96	96"	685 lbs.	7	35 - 50 HP
4500-BB-60	60"	495 lbs.	5	25 - 45 HP
4500-BB-66	66"	528 lbs.	5	25 - 45 HP
4500-BB-72	72"	560 lbs.	6	25 - 50 HP
4500-BB-84	84"	624 lbs.	6	30 - 55 HP
4500-BB-96	96"	684 lbs.	7	35 - 55 HP

Series 233 Hay Handling Equipment

3-Point Bale Mover

STANDARD FEATURES

Rated for Round Bales up to 2000 lbs.
 High Quality Forged Penetrator Spear
 Tapered Spear Allows Easier Access for Quicker Bale Moving
 Stabilizer Rods Designed to Steady Bales



RS-500

Bucket Spike

STANDARD FEATURES

Rated for Round Bales up to 2000 lbs.
 High Quality Forged Penetrator Spear
 Tapered Spear Allows Easier Access for Quicker Bale Moving
 Stabilizer Rods Designed to Steady Bales
 Mounts to bucket and secured with a single bolt



BS-325

Platform Bale Mover

STANDARD FEATURES

Rated for Round Bales up to 2000 lbs.
 Specially Designed Tapered Forks Slide under the Bale,
 Minimizing Bale Damage
 Designed for Minimal Field Damage and Safe Bale Transport



E-511

Universal Bale Spear

STANDARD FEATURES

Rated for Bales up to 2000 lbs.
 Attaches to Front Loader Hydraulic Arms (Bucket Must Be Removed)
 Using Supplied Pins and Universal Sliding Brackets
 Also Attaches to 3-pt hitch
 High Quality Forged Tapered Penetrator Spear
 Stabilizer Rods Are Designed to Steady Bales



F-602

Model #	Weight Rating	Approx. Ship Wt.	Hitch Category
233-RS-500	2000 lbs.	105 lbs.	Cat. I & II
233-BS-325	2000 lbs.	90 lbs.	Bucket Mount
233-E-511	2000 lbs.	191 lbs.	Cat. I & II
233-F-602	2000 lbs.	244 lbs.	Cat. I & II / Loader Mount

“DO IT THE TAYLOR-WAY”

Taylor Pittsburgh Mfg. • Athens, TN • (423) 745-3110

Series 233 Specialty Equipment

Carry All



Taylor Pittsburgh's Carry All is a versatile tool with hundreds of uses. The frame is made of heavy duty angle iron with pre-punched holes which readily accept plywood or plank lumber to create a working platform. With a lift capacity of 1,000 lbs., it makes a great tool to carry feed, rocks, wood and fencing supplies, plus much more.

CA

QuickHitch
Compatible

Pallet Mover

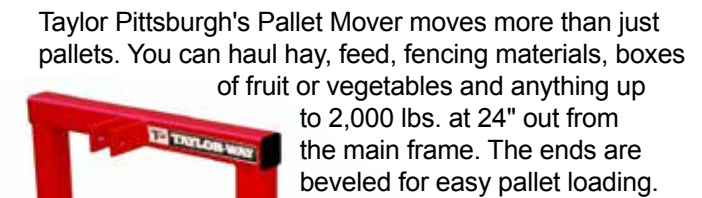

Taylor Pittsburgh's Pallet Mover moves more than just pallets. You can haul hay, feed, fencing materials, boxes of fruit or vegetables and anything up to 2,000 lbs. at 24" out from the main frame. The ends are beveled for easy pallet loading.

PM-15

QuickHitch
Compatible

Wire Unroller

Taylor Pittsburgh's Wire Unroller is a necessary tool for any farm or ranch. It is compatible with standard 2" receiver hitches, and comes standard with an ATV mount.



WU-R

Boom Pole

The Boom Poles are a great 3-pt hitch lifting tool. The standard Boom Pole has a non-moving lifting capacity of 500 lbs. The Heavy Duty Boom Pole is quick hitchable and has a non-moving lifting capacity of 2,000 lbs.



BP

Trailer Mover

The Trailer Mover is built out of square tubing. It features a 2" square tube receiver hitch and unique safety chain. The TM model has a Cat. 1, 3-pt. hitch and the TM-GN model has a Cat. 1, 3-pt straddle hitch as well as a 2 5/16" welded ball.



TM-GN

QuickHitch
Compatible



TM

Heavy Duty Boom Pole



BP-HD

Model #	Weight Rating	Approx. Ship Wt.	Hitch Category
233-CA	1000 lbs.	97 lbs.	Cat. I
233-PM-15	2000 lbs.	158 lbs.	Cat. I
233-WU-R	1 roll up to 80 rod	20 lbs.	NA
233-BP	500 lbs.	65 lbs.	Cat. I
233-BP-HD	2000 lbs.	150 lbs.	Cat. I & Cat. II
233-TM	not rated	67 lbs.	Cat. I
233-TM-GN	not rated	76 lbs.	Cat. I

Series 923 / 4000 Sub-Compact Equipment

Sub-Compact Gear Drive Rotary Tiller

The Patented Series 923 Sub-Compact Gear Drive Rotary Tillers are built to last. The adjustable skid shoes control the cutting depth while the rear shield controls the soil mix, that hold moisture and reduces erosion. Each tiller's driveline is slip clutch protected. These tillers are a must for vegetable or hobby farmers, landscape contractors, nurseries and much more.



Model	Width	Approx. Ship Wt.	Hitch Category	HP Range
923-GDT-48	48"	489 lbs.	Limited Cat. I	Up to 25 HP
923-GDT-54	54"	520 lbs.	Limited Cat. I	Up to 35 HP

STANDARD FEATURES

Limited Cat. I Hitch
 Slip Clutch Protected Drive Line
 6 Tines Per Flange
 All Gear Driven
 Patented Kickstand

1.5 Ton Sub-Compact Dump Trailer

Taylor Pittsburgh's 1.5 Ton Sub-Compact Dump Trailer is ideal for landscaping, choring, gardening, and construction jobs. This trailer features a unique two-way tailgate that will open from the top (like a pickup truck) to load or unload large bulky items or will open from the bottom (like a dump truck). This unit is constructed with 12 gauge formed steel sides and end panels for maximum strength and durability. The 1.5 ton Dump Trailer is designed for off road use not to exceed 20 mph.

Model	Approx. Ship Wt.
4000-1.5T-MP	864 lbs.

STANDARD FEATURES

Rear Dump
 Swivel Clevis Hitch
 Swivel 2" Ball Hitch
 18 X 8 ½ X 8 Turf Style Tires
 Walking Beam Tandem Axle
 Double Acting Pump
 Single Action 3" X 12" Cylinder
 Bed Dimensions 70"L X 50"W X 13"H



"DO IT THE TAYLOR-WAY"

Taylor Pittsburgh Mfg. • Athens, TN • (423) 745-3110

Series 233 Sub-Compact Equipment

4' Sub-Compact Rotary Cutter

Taylor Pittsburgh's Sub-Compact Rotary Cutter is a quality constructed durable Cutter that is built to last. It is constructed with rugged steel side rails and has a one piece top deck that is fully reinforced. Standard features include a cast iron gearbox, stump jumper, twin tail wheels and a shielded PTO shaft with a shear pin.



STANDARD FEATURES

- Rugged Steel Side Rails
- Heavy Gauge, One Piece Top Deck
- Adjustable Tail Wheels
- Heavy Duty, Cast Iron Gearbox
- Shielded Pto Shaft with Shear Pin
- Heavy Stump Jumper
- Forged, Heat Treated Blades
- Top Link Swivel
- Rubber Shielding Standard

Model	Approx. Ship Wt.	Hitch Category	HP Range
233-L-48-40-SC	422 lbs.	Limited Cat. I	Up to 25 HP

4' Sub-Compact Finish Mower

Taylor Pittsburgh's Sub-Compact Finish Mower is built with all the quality and features of larger finish mowers. The patented free-floating flex hitch system allows the mower to follow the contours of the ground to deliver an exceptional cut.



STANDARD FEATURES

- Rugged Steel Side Rails
- Heavy Duty Steel Deck
- Heavy Duty Cast Iron Gearbox
- Single Belt With EZ Adjustment System
- Turf Friendly, 4 Ply Pneumatic Tires
- Shielded Pto Shaft with Shear Pin
- Anti-Scalp Roller
- Fully Baffled Deck
- Easy Height Adjustment

Model	Approx. Ship Wt.	Hitch Category	HP Range
233-RFM-48-SC	424 lbs.	Limited Cat. I	Up to 25 HP

Series 233 Sub-Compact Equipment

4' Sub-Compact Box Blade

Taylor Pittsburgh's Patented Sub-Compact Box Blade is designed for rugged use by landscapers, farmers, and homeowners, on sub-compact tractors with a Limited Cat. I, 3-point hitch. They are great for landscaping, land leveling, back-filling, grading, and many more jobs.

STANDARD FEATURES

2" X 4" Rectangular Box Shank Housing
 Flip Up Ripper Shanks
 Front and Rear Cutting Edges



Model	Approx. Ship Wt.	Hitch Category	HP Range
233-BB-48-SC	295 lbs.	Limited Cat. I	Up to 25 HP

5' Sub-Compact Rear Blade

Taylor Pittsburgh's Sub-Compact Rear Blade is designed for landscaping, snow removal, cleaning livestock pens, road and drive-way maintenance, and much more. Ideal for use on today's subcompact tractors with Limited Cat. I, 3-point hitches.

STANDARD FEATURES

5 Forward & 5 Reverse Settings
 Reinforced, 3-Point Square Tube Frame for Extra Strength



Model	Approx. Ship Wt.	Hitch Category	HP Range
233-TRB-60-SC	191 lbs.	Limited Cat. I	Up to 25 HP

5' Sub-Compact Landscape Rake

Taylor Pittsburgh's Sub-Compact Landscape Rake is engineered for versatility for the landscaper or homeowner. It is great for gravel road grading, lot maintenance, seed bed preparation, the removal of rocks, roots, trash, plus much more. The unique design features an adjustable stabilizer bar that allows the heat treated spring steel tines to be more or less rigid.

STANDARD FEATURES

Reinforced, 3-Point Square Tube Frame for Extra Strength
 5 Forward & 5 Reverse Settings
 Tines Individually Mounted for Durability
 Adjustable Stabilizer Bar



Model	Approx. Ship Wt.	Hitch Category	HP Range
233-TYR-60-SC	191 lbs.	Limited Cat. I	Up to 25 HP

“DO IT THE TAYLOR-WAY”

Taylor Pittsburgh Mfg. • Athens, TN • (423) 745-3110

Series 233 Sub-Compact Equipment

5' Sub-Compact Angle Frame Disc

Taylor Pittsburgh's Sub-Compact Angle Frame Disc features a heavy angle iron frame construction, 1" square high carbon steel axles, sealed bearings and adjustable axle angle settings. It's a field ready disc harrow that's built to last.

STANDARD FEATURES

- Sealed Bearings
- Adjustable Angle Settings
- 14" High Carbon Notched Steel Disc Blades



Model	Approx. Ship Wt.	Hitch Category	HP Range
233-14-16-N-SC	418 lbs.	Limited Cat. I	Up to 25 HP

Sub-Compact Spreader

Taylor Pittsburgh's Sub-Compact Spreader is especially designed for sub-compact tractors with 3-point hitches. Taylor Pittsburgh's Sub-Compact Spreader has 2 control levers easy to reach from the tractor and a uniform spreading pattern.

STANDARD FEATURES

- Gearbox with Shielded Drive Line
- Uniform Spreading
- Balanced Distribution with 4 Fins
- Limited Cat. I Hitch
- Approx. 400 Pound Capacity

Model	Approx. Ship Wt.	Hitch Category	HP Range
233-S-SC	118 lbs.	Limited Cat. I	Up to 25 HP



Sub-Compact Middle Buster/Sub-Soiler

Taylor Pittsburgh's Sub-Compact Middle Buster/Sub-Soiler combines strength and durability to offer a tool with many uses. The middle buster point is great for laying off rows, digging potatoes, pointing a ditch, general field prep, and many other farm, field, and garden uses. The sub-soiler point is for ripping sod and loosening compacted soil.

STANDARD FEATURES

- Thick Walled Tubular Shank
- Heavy Duty Steel Frame
- Heat Treated Furrower and Sub-Soiler Point

Model	Approx. Ship Wt.	Hitch Category	HP Range
233-MB-S-SC	40 lbs.	Limited Cat. I	Up to 25 HP



Series 233 ATV Attachments

Flip Over Disc

Taylor Pittsburgh's Flip Over Disc is designed for the toughest applications. It features a full 3" square tube frame that can be weighted, with 1" square axles, 16" notched blades and maintenance free sealed bearings. A full 4-foot cutting width with 20 degrees cutting angle and an adjustable height tongue for various sizes of 4-wheelers or small tractors. It also has a rear receiver hitch (ball hitch not included) so you can pull an ATV seeder or drag harrow for maximum efficiency.

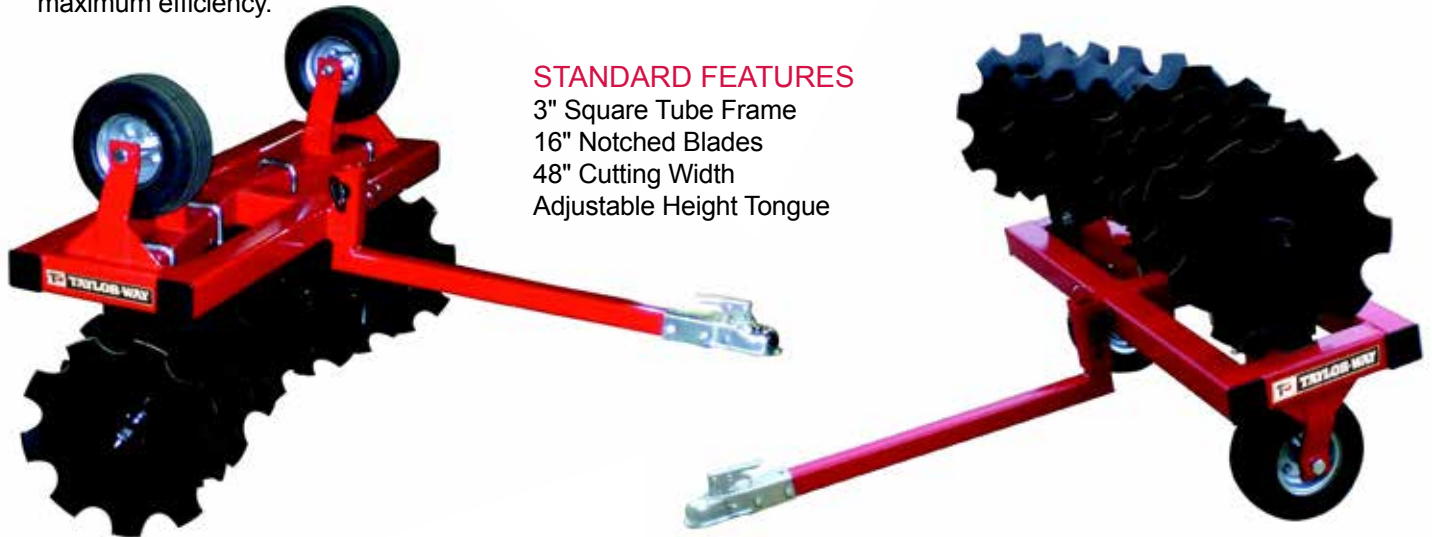

STANDARD FEATURES

- 3" Square Tube Frame
- 16" Notched Blades
- 48" Cutting Width
- Adjustable Height Tongue

Model	Width	Approx. Ship Wt.	Hitch Category	Hitch Ball Diameter	# of Blades	Blade Diameter	Blade Thickness
233-16-8-CDF	48"	309 lbs.	Pull Type	1 7/8"	8	16"	3.0 MM

Cultipacker

Taylor Pittsburgh's Cultipacker is great for getting those seeds into the soil, whether it is in your yard, pasture or food plots. The Cultipacker can be pulled with an ATV or a compact tractor with a ball hitch. It is easy to flip over from tires for transport to packer wheels for working the soil.

STANDARD FEATURES

- 3/8" Steel Frame
- 1 7/8" Ball Hitch
- 48" Working Width
- Easy Flip Over
- 20 Individual Cast Iron Packer Wheels
- Greasable Wheel Shaft Bearings



Model	Operating Width	# of Packer Wheels	Approx. Ship Wt.
233-KP-48-ATV	48"	20	307 lbs.

"DO IT THE TAYLOR-WAY"

Taylor Pittsburgh Mfg. • Athens, TN • (423) 745-3110

33" Compact Disc

Taylor Pittsburgh's 233-14-10-CD Compact Disc is perfect for use in wildlife food plots, small gardens, row cultivation, and yard prep work. It features a square tube frame, 1" high carbon steel axles, maintenance free sealed bearings, 14" notched disc blades, and a unique pull tongue design that allows down pressure to be applied without the need of additional weight. The wheeled design is engineered for smooth transition from off-road transport to working position.



Model	Width	Approx. Ship Wt.	Hitch Category	Hitch Ball Diameter	# of Blades	Blade Diameter	Blade Thickness
233-14-10-CD	33"	235 lbs.	Pull Type	1 7/8"	10	14"	3.0 MM

48" Compact Disc

Taylor Pittsburgh's 233-14-14-CD Compact Disc features a strong square tube frame, 1" square axles, sealed bearings, and notched disc blades. The swing up axle design is engineered to make the transition from transport to working mode easily. With a 48" working width, the 233-14-14-CD is great for wildlife plots and smaller patches of ground.



Model	Width	Approx. Ship Wt.	Hitch Category	Hitch Ball Diameter	# of Blades	Blade Diameter	Blade Thickness
233-14-14-CD	48"	305 lbs.	Pull Type	1 7/8"	14	14"	3.0 MM

Series 233 ATV Attachments

Drag Harrows

Taylor Pittsburgh's Drag Harrows are the ideal tool for pasture renovation and maintenance. The Drag Harrows spread and incorporate manure, thatch dead growth, aerate soil, increase moisture penetration, and renovate pastures by preparing soil for seeding while stimulating existing growth. Taylor Pittsburgh's Drag Harrows are a must for the progressive farmer, rancher, horse owner, landscaper or grounds keeper.

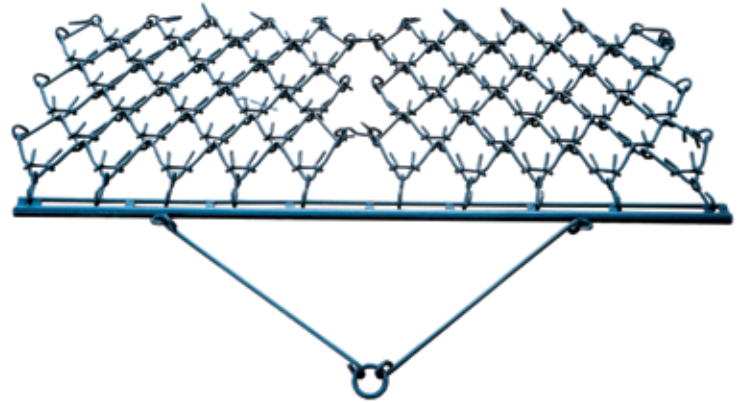

Model	Width	Length	Approx. Ship Wt.
233-DH-48	48"	48"	99 lbs.
233-DH-96	96"	48"	191 lbs.

STANDARD FEATURES

- Tines ½" Diameter by 4 ½" Long
- No Parts to Lubricate or Adjust
- Offset Tines Eliminate Ridges
- Evenly Works the Ground Regardless of the Terrain
- Cold Formed Tines Eliminate Breakage
- Can Be Operated at Speeds Up to 8 mph

ATV Seeder/Spreader

Taylor Pittsburgh's ATV Seeder/Spreader is the ideal implement for use when a PTO is not available. This unit has a ground driven gearbox that can be disengaged when transporting. It is ideal for spreading seed and fertilizer. It has an adjustable tow bar with a 1 ⅞" ball hitch. It has 16" diameter tires that are 6 ½" wide which makes this a "Turf Friendly" implement. This item is a must for landscapers, contractors, hunters and small farmers.



Model	Approx. Ship Wt.
233-S-ATV-180	179 lbs.

STANDARD FEATURES

- Up to 400 lb. Load Capacity
- 16" X 6 ½" Turf Tires
- Windrift Shield
- Adjustable Tow Bar
- Gearbox Disengages for Transporting

"DO IT THE TAYLOR-WAY"

Taylor Pittsburgh Mfg. • Athens, TN • (423) 745-3110

Series 233 Seeder / Spreader

Seeder/Spreader (Steel)

Taylor Pittsburgh's Seeder/Spreader (Steel) gives new meaning to the word adaptable. With this one tool you can spread seed, granular fertilizer, crystalline herbicides, pesticides and sand. Plus, you can choose from three different spreading patterns; predominately left, predominately right, or left and right. The seamless all steel Seeder/Spreader is strong enough to endure rough handling and heavy use. The heat treated paint resists corrosion caused by chemicals and moisture. Each unit comes standard with a rotating agitator and gearbox with shielded drive line.

STANDARD FEATURES

Fits Cat. I, 3-Point Hitch Tractors
Seamless Conical Steel Hopper
Adjustable Uniform Spreading Rates From 18 To 800 lbs. Per Acre
Effective Spreading Widths from 39' to 46'
Choice of Three Spread Patterns Full Rear Pattern, Left Side, Right Side
Up to 900 lb. Capacity

Model	Approx. Ship Wt.
233-S-500	122 lbs.



Seeder/Spreader (Polyethylene)

Taylor Pittsburgh's Seeder/Spreader (Polyethylene) is an ideal tool for farmers, ranchers, gardeners, and landscapers. This Seeder/Spreader can spread grass seed, granular fertilizer, crystalline herbicides, pesticides, sand and salt. You can choose from three different spreading patterns; predominately left, predominately right, or left and right. The seamless polyethylene hopper is strong enough to endure rough handling and is ideal for use with today's highly corrosive fertilizers and herbicides. Each unit comes standard with a greaseable gearbox and shielded PTO shaft.

STANDARD FEATURES

Fits Cat. I, 3-Point Hitch Tractors
Seamless Tough Polyethylene Hopper
3 Different Spreading Patterns
Adjustable Uniform Spreading Rates
Greaseable Gearbox with a Shielded PTO Shaft
Spreads Sand, Salt And Today's Corrosive Fertilizers
Up to 800 lb. Capacity



Model	Approx. Ship Wt.
233-S-400-P	119 lbs.

Series 4000 Dump Trailers

Five models are available from a 1.5 ton model, which is ideal for landscaping or light construction use up to an 8 ton model which is built rugged enough for most farm or construction needs.

All models feature removable hinged tailgates, removable side panels and swivel clevis type hitch. Tongue Jacks are standard on all models.

All tandem axle models feature a center pivot walking tandem axle, which allows uniform load distribution on uneven terrain.

The 4 and 5 ton models feature a unique 3-way dumping design. This is possible by the use of an oscillating telescopic single acting cylinder. The dumping pattern can be changed from rear to right or left by the simple placement of two hinge pins.

Model 4000-1.5T-50x72



1.5T FEATURES

- 1.5 Ton Capacity
- Rear Dump
- Removable Reinforced Side and End Panels
- 2 Way Opening Tailgate
- Swivel Clevis and Ball Hitch
- Walking Beam Tandem Axle with 18 x 1.5 x 8 Tires
- Double Action Cylinder
- Fold Away Tongue Jack

This model available with manual hydraulic pump. See page 34 for details.

2.5T FEATURES

- 2.5 Ton Capacity
- Rear Dump
- Removable Reinforced Side and End Panels
- Walking Beam Tandem Axle with 23 x 8.5 x 12 Tires
- Swivel Clevis Hitch
- Double Action Cylinder
- Fold Away Tongue Jack

Model 4000-2.5T-60x96



4T FEATURES

- 4 Ton Capacity
- 3 Way Dump (Right, Left, or Rear)
- 3 Stage Single Action Telescope Hydraulic Cylinder
- Single Axle With 11L x 15 Tires
- Removable Reinforced Side and End Panels
- Swivel Clevis Hitch
- Fold Away Tongue Jack
- Optional Grain Gate

Model 4000-4T-63x99



“DO IT THE TAYLOR-WAY”

Taylor Pittsburgh Mfg. • Athens, TN • (423) 745-3110

5T FEATURES

Model 4000-5T-63x99

- 5 Ton Capacity
- 3 Way Dump (Right, Left, or Rear)
- 3 Stage Single Action Telescope Hydraulic Cylinder
- Walking Beam Tandem Axle with 11L x 15 Tires
- Removable Reinforced Side and End Panels
- Swivel Clevis Hitch
- Fold Away Tongue Jack
- Optional Grain Gate



Model 4000-8T-60x120



8T FEATURES

- 8 Ton Capacity
- Rear Dump
- 2 Double Action Cylinders
- Walking Beam Tandem Axle with 11L x 15 Tires
- Swivel Clevis Hitch
- Removable Reinforced Side and End Panels
- Fold Away Tongue Jack
- Optional Grain Gate

Series 4000 Dump Trailers

Model #	1.5T-50x72	2.5T-60x96	4T-63x99	5T-63x99	8T-60x120
Capacity Weight	1.5 ton	2.5 ton	4 ton	5 ton	8 ton
Capacity	35 cubic ft.	77 cubic ft.	2.5 cubic yd.	2.5 cubic yd.	3.5 cubic yd.
Tire Size	18 x 9.5-8	23 x 10.5-12	11L x 15	11L x 15	11L x 15
No. of Tires	4	4	2	4	4
Weight	600 lbs.	1600 lbs.	1825 lbs.	1900 lbs.	2050 lbs.
Bed Width	50"	60"	63"	63"	60"
Bed Length	72"	96"	99"	99"	120"
Bed Height	21"	30"	33"	33"	31"
Bed Floor	12 ga. steel	3/16" plate	3/16" plate	3/16" plate	3/16" plate
Overall Width	54"	64"	68"	66"	88"
Overall Length	8' 6"	11' 8"	11' 6"	11' 6"	13' 8"
Overall Height	34"	52"	61"	61"	61"
Dump Angle	45°	45°	45°	45°	45°
Side Panels	13" high	14" high	14" high	14" high	16" high
Rear Panels	14" high	19" high	18" high	18" high	24" high
Front Panels	13" high	19" high	18" high	18" high	24" high

*All Specs are approximate.**For Off Highway Use Only.



TAYLOR-WAY

Pro Haul Dump Trailer

This versatile Tandem Axle Dump Trailer is highway approved and is a perfect match for property owner, landscaper, contractor and rental yard applications. This rugged rear Dump Trailer has a G.V.W. rating of 9,980 lbs. and features tandem 6,000 lb. axles, with a self contained 12 volt hydraulic dumping system. The sturdy frame and bed construction is designed to provide years of dependable hauling service.

Pro-Haul Dump Trailer	Specifications
G.V.W.R. (gross vehicle weight rating)	9,980 lbs.
Axles	Tandem 6,000 lbs. Axles with 6Bolt E-Z Lube Hubs
Box Length	120"
Box Width	80"
Side board Height	18"
Box Capacity	3.7 Cubic Yards
Tie Rails	½" All Sides
Tie-down Anchors	D-Ring (2 Each Side)
Suspension	Leaf Springs
Hitch Coupler	2-5/16" Ball Hitch
Safety Chains	¼" Proof Coil with 5/16" Safety Hooks
Main Frame Construction	6" Channel
Floor Construction	10 Gauge
Fender Construction	11 Gauge
Rear Gate	Double Swinging
Tires	225/75R16 on 16" x 6" Rims
Lights	DOT Class. with 6 Wire Plug
Lift Mechanism	Hydraulic Cylinder
Hydraulic System	12-Volt with Deep Cycle Battery Standard in Lockable Storage Box
Dump Control	Hand-Held Remote
Safety Break-Away System	Standard Equipment
Tongue Jack	Standard with Side Crank
Approximate Weight (empty)	2,990 lbs.



“DO IT THE TAYLOR-WAY”

Taylor Pittsburgh Mfg. • Athens, TN • (423) 745-3110

Series 775 Stump Cutter

Stump Cutter

You have seen stump grinders. Now check out the all new, Patent Pending, Taylor Pittsburgh Stump Cutter! It will change the way you think about stump removal. The innovative 30" diameter head engages a large area of the stump simultaneously. It drastically reduces the amount of time it takes to remove a stump, and therefore increases productivity. In fact it can take a 30" diameter stump and cut it down 18" in less than 15 minutes, powered simply by the tractor's PTO. Heavy Duty cam-type cut-out clutch, lift arm stabilization kit and storage stands come standard with the Taylor Pittsburgh Stump Cutter.

Model	Cutting Width	Hitch Category	Approx. Ship Wt.	HP Range
775-SK-30	30"	CAT. II	1444 lbs.	50 - 55 HP



Hydraulic Top Link Recommended

Series 915 Post Hole Digger

The New "Patent Pending" Taylor Pittsburgh Post Hole Diggers are the latest in post hole digger innovation from Taylor Pittsburgh Manufacturing. This post hole digger features a 3-point Cat. I hitch, a unique patent pending Quik-Tach™ threaded auger, a slip clutch driven gearbox and 6", 9" & 12" augers with patent pending "Butterfly Flighting".

Taylor Pittsburgh's Post Hole Digger features a heavy duty, square tube formed frame and is designed and built with safety in mind. Taylor Pittsburgh's Post Hole Diggers are built for the farmer, contractor, and landscaper.

Standard Features

- 3 Auger Sizes 6", 9" or 12" with Butterfly Flighting
- Quik-Tach™, Threaded Auger
- Replaceable, Cast Steel, Split Tip Auger Point
- Replaceable, Heat Treated, Cutting Edges
- Square Tube Formed Frame
- PTO with Slip Clutch
- Accommodates Cat. I, 3-Point Hitch
- Safety Shield Integrated into Structure

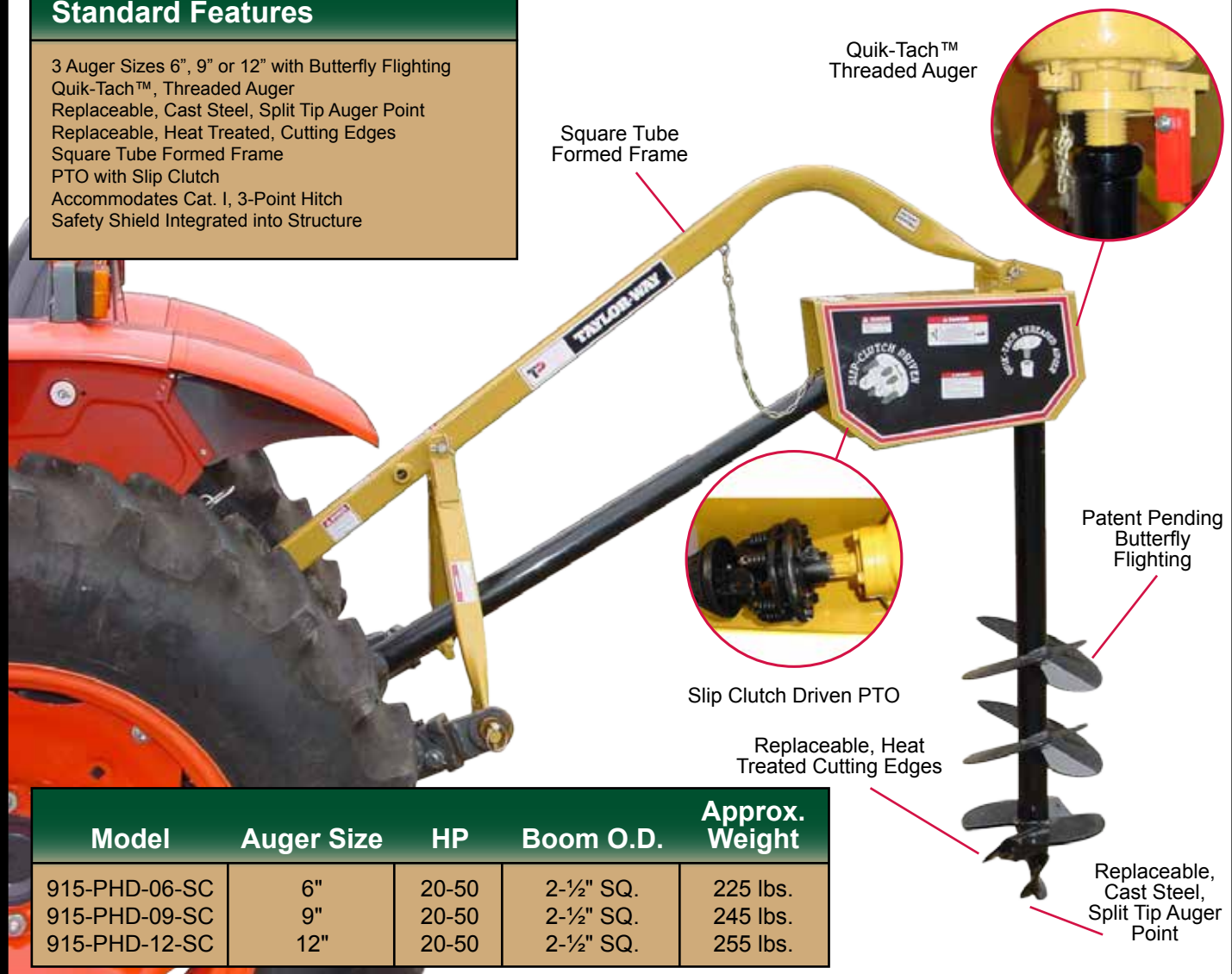

Model	Auger Size	HP	Boom O.D.	Approx. Weight
915-PHD-06-SC	6"	20-50	2-½" SQ.	225 lbs.
915-PHD-09-SC	9"	20-50	2-½" SQ.	245 lbs.
915-PHD-12-SC	12"	20-50	2-½" SQ.	255 lbs.



Look for this icon throughout this catalog to find many Quick Hitch Compatible products available from Taylor Pittsburgh.



"DO IT THE TAYLOR-WAY"
 Taylor Pittsburgh Mfg. • Athens, TN • Phone (423) 745-3110
 A division of King Kutter Inc.

Taylor Pittsburgh, Mfg. reserves the right to change model numbers, optional equipment and product specifications without notice.

