

METRIS

The new 2016 Mercedes-Benz Mid-Size Van

Starting at \$28,950*



Mercedes-Benz
Vans. Born to run.

The next big thing is mid-sized.

Mercedes-Benz Vans is innovating. Again. Our family is growing stronger with the new 2016 Metris, the Mid-Size Van that's also the right-size van. Available as a Cargo or Passenger Van, the Metris has large capabilities in a small footprint that delivers in crowded streets, commercial garages and virtually any jobsite.

The Metris carries your company forward with standard and optional safety innovations that protect you and your business mile after mile. Plus, our highly fuel-efficient gasoline engine with optional ECO Start/Stop, 7G-tronic transmission, service intervals of up to 15,000 miles and Mercedes-Benz durability help lower your total cost of ownership. When you're ready to grow larger, think smaller. With the Metris.

Starting at \$28,950*

Arriving Fall 2015



Every trip. Maximized.

Discover why the Metris Van is the right size for your business.

You need a van that adapts to your business yet is tough enough to outwork your competition every day. Meet the Metris and size up a wise choice.

Mercedes-Benz, the name that revolutionized the commercial van market with the business-building Sprinter, introduces a mid-size van that thinks big. Whether you select the Cargo or Passenger Van model, the Metris features car-like ride and handling that's an extraordinary fit for a range of businesses, including delivery, maintenance, mobile workshops, taxis, shuttles and many others.

METRIS PASSENGER VAN

QUICK FACTS

Standard seating for driver plus six adult passengers

Sliding doors on driver and passenger sides

Optional seating for seven plus driver

38.7" turning radius

Six airbags, including rear-compartment window bags¹

Attention Assist²

(see reverse side for additional technical data)



Possibilities. Delivered.

Take advantage of every opportunity with the Metris Van.

Even with its high payload and ample cargo volume, the new Metris features a small footprint that also offers the comfort, room and maneuverability you need – without compromising anywhere.

The Metris includes innovative standard and available safety features to protect both you and your business. Plus, custom options let you add comfort and functionality perfectly suited to your business. Built for the long haul, your Metris reduces your total cost of ownership, thanks to economical operating costs and renowned Mercedes-Benz quality. Do business with the Metris – the smarter way to work.

METRIS CARGO VAN

QUICK FACTS

4,960 lbs. towing capacity

186 cu. ft. cargo volume

2,502 lbs. max. payload

111.5" cargo length
with through-loading partition

37.8" side door opening width

Standard wood floor

(see reverse side for additional technical data)







Take a close look at the new Metris.

KEY FEATURES

- 4,960 lbs. towing capacity
- 2,502 lbs. max. payload (1,874 lbs. for Passenger Van)
- 186 cu. ft. cargo volume (38 cu. ft. for Passenger Van)
- 126" wheelbase
- 202.4" body length
- 6,724 lbs. GVWR
- 17" steel wheels
- Audio15 Sound System with 5.8" full-color screen
- Service intervals of up to 15,000 miles
- Standard wood floor (Cargo Van)
- Choice of three rear doors: 270°, 180° or tailgate (choice of 180° or tailgate for Passenger Van)
- Passenger Van: sliding doors on both sides, plus seating for up to seven plus driver

POWERTRAIN

- Turbocharged 2-liter, 4-cylinder gasoline engine with direct injection
- 208 horsepower
- 258 lb.-ft. torque
- 7-speed automatic transmission
- Rear-wheel drive
- Impressive fuel economy
- Optional ECO Start/Stop

CAPACITIES

Fuel Tank	18.49 gal.
Max. Roof Load	331 lbs.
Max. payload (Cargo Van/Passenger Van)	2,502 lbs./ 1,874 lbs.
GAWF/GAWR	3,417 lbs.
Towing	4,960 lbs.
GVWR	6,724 lbs.
GCWR	11,684 lbs.

SELECT SAFETY AND CONVENIENCE FEATURES

STANDARD

- ATTENTION ASSIST^{®2}
- Load-Adaptive ESP[®]
- Crosswind Assist³
- Six standard airbags
- Window bags for rear compartment (Passenger Van)¹

OPTIONAL

- Active Parking Assist
- COLLISION PREVENTION ASSIST⁴
- Blind Spot Assist⁵
- Lane Keeping Assist⁴
- Anti-theft alarm system
- PARKTRONIC
- Rear View Camera⁷
- Reversing warning device



DIMENSIONS

CARGO PASSENGER

	CARGO	PASSENGER
Length	202.4"	
Width (w/o mirrors)	75.9"	
Width (w/ mirrors)	88.3"	
Height	75.2"	74.4"
Height with roof rails	77.1"	76.3"
Wheelbase	126.0"	
Overhang front/rear	35.3"/41.1"	
Cargo Length (w/o partition)	105.4"	27.5"
Cargo Length (w/thru-loading partition)	111.5"	n/a
Max. Cargo Width	66.3"	61.1"
Cargo Floor Width (btw. wheelhouse)	50.0"	47.4"
Min. Cargo Height	53.8"	52.2"
Max. Cargo Height	55.0"	52.4"
Cargo Volume	186.0 cu. ft.	38.0 cu. ft.
Side Door Opening Width (at floor)	37.8"	35.5"
Turning Radius Wall to Wall	38.7"	
Headroom (driver/passenger)	39.6"	
Headroom (2nd row, middle seat)	n/a	41.5"
Headroom (3rd row, middle seat)	n/a	40.5"

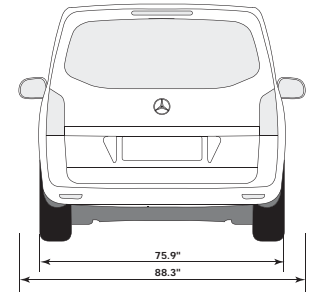
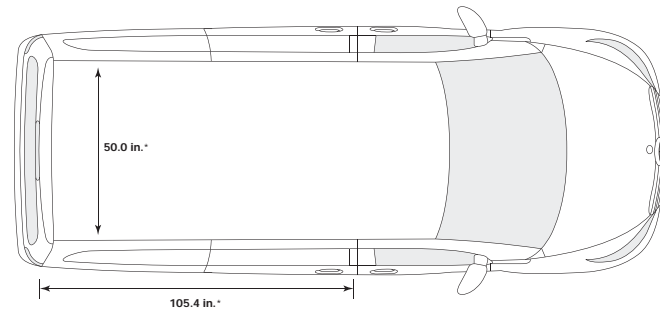
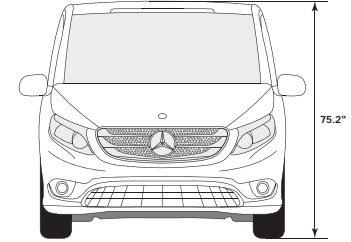
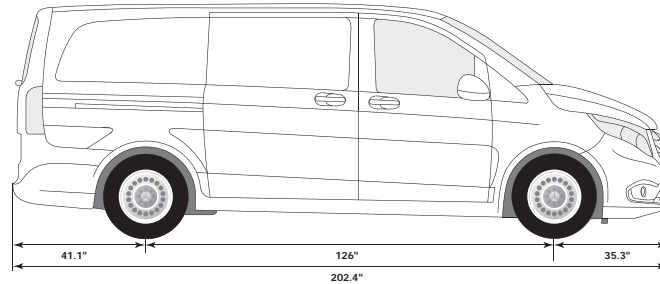

*Cargo Van

ENDNOTES

* Excludes all options, taxes, title, registration, transportation charge and dealer prep fee.

1. Warning: the forces of a deploying airbags can cause serious or fatal injuries to a child under age 13. The safest seating position for your child is in a rear seat, belted into an appropriate, properly installed child seat, or correctly wearing a seat belt if too large for a child seat. See Operator's Manual for additional warnings and information on airbag, seat belts and child seats.
2. Driving while drowsy or distracted is dangerous and must be avoided. ATTENTION ASSIST® may be insufficient to alert a fatigued or distracted driver and cannot be relied on to avoid an accident or serious injury.
3. Crosswind Assist engages automatically when sensing dangerous wind gusts at highway speeds exceeding 50 mph. Performance is limited by wind severity and available traction, which snow, ice and other conditions can affect. Always drive carefully, consistent with conditions.
4. COLLISION PREVENTION ASSIST may not be sufficient to avoid an accident. It does not react to certain stationary objects, nor recognize or predict the curvature and/or lane layout of the road or every movement of vehicles ahead. It is the driver's responsibility at all times to be attentive to traffic and road conditions, and to provide the steering, braking and other driving inputs necessary to retain control of the vehicle. Drivers are cautioned not to wait for the system's alerts before braking, as that may not afford sufficient time and distance to brake safely.

5. Blind Spot Assist may not be sufficient to avoid all accidents involving vehicles in your blind spot and does not estimate the speed of approaching vehicles. It should not be used as a sole substitute for driver awareness and checking of surrounding traffic conditions.
6. Lane Keeping Assist may be insufficient to alert a fatigued or distracted driver of lane drift and cannot be relied on to avoid an accident or serious injury.
7. Rear view camera is not a substitute for actively checking around the vehicle for any obstacles or people. Images displayed may be limited by camera field of view, weather, lighting conditions and the presence of dirt, ice or snow on the camera.

©2015 Mercedes-Benz USA, LLC, One Mercedes Drive, Montvale, NJ 07645 1-877-762-8267
All illustrations and specifications contained in this brochure are based on the latest product information available at the time of publication. Volume measurements are according to SAE J1100. Mercedes-Benz reserves the right to make changes at any time, without notice, in colors, materials, equipment, specifications and models. Any variations in colors shown are due to reproduction variations of the printing process. Illustrations may include test situations. Some vehicles may be shown with non-U.S. equipment. Some vehicles are shown with optional equipment available at extra cost. Some optional equipment may not be available individually and/or on all models. For current information regarding the range of models, standard features, optional equipment and/or colors available in the U.S. and their pricing, please contact your nearest authorized Mercedes-Benz Vans dealer. All rights reserved.

www.mbvans.com/metris

SMB-15-1044 Printed in U.S.A.

Revision 3, April 2015



Mercedes-Benz
Vans. Born to run.