



2017
WRANGLER

Jeep[®]



WRANGLER

Capability without compromise. That's what Wrangler drivers count on, and for over 75 years, the Jeep® brand has delivered. As part of Canada's most capable SUV brand,¹ Wrangler is renowned for taking riders on a serious exploration of worldly wilds, while maintaining the poise to deliver a comfortable driving experience from trails to city streets.

Wrangler is powered by Canada's Best-Selling engine,² the iconic 3.6L Pentastar™ Variable Valve Timing (VVT) V6, a three-time *Wards* "10 Best Engines" winner.³ Wrangler delivers unsurpassed towing capability³ so you can bring along even more fun.

The Jeep brand reigns as Canada's Best-Selling line of SUVs,⁴ and Wrangler stands tall as the favourite 4x4 with the determination to take you places others only dream of reaching.

*All disclaimers and disclosures can be found on page 21.
†2011, 2012 and 2013.

CANADA'S MOST
CAPABLE SUV⁵

Best-in-Class
GROUND
CLEARANCE⁶

Best-in-Class
HORSEPOWER⁶

UNSURPASSED
TOWING³

"4x4 OF THE DECADE"⁷
FOUR WHEELER[®]

WITH CAPABILITY
COMES POSSIBILITY



TAKE ON THE WORLD

TRU-LOK® DIFFERENTIALS Tru-Lok® front and rear electronic-locking differentials balance speed between the left and right wheels, maintaining forward momentum for the ultimate in traction. An instrument panel-mounted rocker switch can lock either the rear or both axles. (Standard on Rubicon®.)

ROCK-TRAC® HEAVY-DUTY PART-TIME 4x4 SYSTEM With its 4:1 low-gear ratio and 73.1:1 crawl ratio, Wrangler Rubicon can crawl at a consistent 0.8 km/h for greater control and increased torque available at the wheels.

COMMAND-TRAC™ PART-TIME 4x4 SYSTEM For authentic Jeep® brand off-road and all-weather capability, this part-time, shift-on-the-fly system divides torque 50/50 between the front and rear axles for tough traction. The NV241 GII transfer case shifts smoothly from 2WD to 4WD HI at speeds up to 88 km/h. For serious rock-crawling, its 2.72:1 low range tackles boulders with confident Jeep brand strength and capability. (Standard on Sport, Sport S, Willys Wheeler, Sahara® and 75th Anniversary Edition models.)

HOOKS AND SKID PLATES Every Wrangler is fortified with underbody armour that protects critical components. Stamped-steel skid plates defend the fuel tank and transfer case while a skid bar safeguards the automatic transmission oil pan. Front and rear tow hooks help when duty calls.

DANA® 44 HEAVY-DUTY AXLES Durability and articulation come from heavy shafts, stiff housing, large pinion bearings and above-centre pinion mountings. The above-centre mounting helps reduce driveshaft joint angles for smooth and quiet operation while adding ground clearance. (Dana® 44 rear axle standard on all models. Dana 44 front axle standard on Rubicon.)

HEAVY-DUTY SUSPENSION Solid axles with locating arms, coil springs, track/stabilizer bars, front steering damper and tunable monotube shock absorbers are firm at low speeds and more relaxed at higher speeds. (Standard on Sahara and 75th Anniversary Edition. Performance suspension is standard on Willys Wheeler and Rubicon.)

ELECTRONIC FRONT SWAY BAR DISCONNECT This system allows you to flip a switch to disengage the sway bar when driving under 29 km/h in 4WD-low (4LO) mode, permitting the front suspension to travel up to 25 percent farther. (Standard on Rubicon.)

CANADA'S MOST CAPABLE 4x4⁵



HARD-CORE 4x4 Confidence to Go Anywhere, Do Anything® is born and bred in every Trail Rated® Jeep brand vehicle. You'll experience standard Class-Exclusive Trail Rated capability⁶ in every Wrangler because they're designed to perform to rigorous standards in five categories: manoeuvrability, articulation, water fording⁹, traction and ground clearance. Wrangler is designed to keep you moving forward, no matter what lies ahead.



RUBICON UNLIMITED HARD ROCK SHOWN IN BILLET METALLIC.



RUBICON® UNLIMITED HARD ROCK SHOWN IN RHINO.



RUBICON SHOWN IN BRIGHT WHITE.

RIGOROUS STANDARDS

MANOEUVRABILITY Every Wrangler is born with the athletic ability to navigate narrow gaps and emergency situations, with precision steering, optimized wheelbases and a tight turning radius.

ARTICULATION Suspension systems enhance on- and off-road performance by maximizing flexibility, axle articulation and wheel travel. The articulation helps to keep all four wheels on the ground, providing greater control over rough terrain and obstacles.

WATER FORDING⁹ Traverse waterways with confidence, thanks to additional electrical and body seals, plus a high air-intake location. Wrangler has the capability to safely manage in up to 76 cm (30 in) of water.⁹ Always inspect all waterways before proceeding.

TRACTION Helps you maintain controlled forward motion on snowy back roads and over icy urban bridges. You can climb steep sand dunes and master muddy tracks. Your Trail Rated® Wrangler has the traction within to master all kinds of topography and driving conditions.

GROUND CLEARANCE Head out knowing that your Trail Rated vehicle has Best-in-Class approach, departure and breakover angles⁶ designed to clear logs, rocks and uneven ground. Your undercarriage is protected, too, with forged skid plates that cover valuable underbody elements.



FOR INSPIRATION, LOOK WITHIN

The long list of standard and available interior options on Wrangler allow you create your very own oasis of comfort and style. Select your multimedia centre and stay connected with offerings that include hands-free communication⁹ with Bluetooth[®] streaming audio, voice text reply,¹⁰ navigation¹¹ and SiriusXM satellite radio with one-year subscription!¹²

The available Alpine[®] premium audio system with eight speakers plus all-weather subwoofer, all powered by a 552-watt amplifier, is engineered to deliver an exceptional audio experience. The folding front-passenger seat on Wrangler two-door models gives easy access to the second row and the available leather-wrapped steering wheel holds convenient hands-free buttons for the Electronic Vehicle Information Centre (EVIC), hands-free communication⁹, audio and cruise control. After a fun day of playing in the dirt over off-road tracks and trails, you can easily wash away leftover interior mud and grime, thanks to Wrangler's removable carpet and drain plugs.

CUSHIONED COMFORT Wrangler's interior seats, available in either premium cloth or leather-faced, are designed to stand up to all kinds of sitting down, with plenty of support so you've got more stamina to keep on going.

LIT FROM WITHIN Interior courtesy lights include illuminated front footwells and cup holders, while an available auto-dimming rearview mirror automatically darkens to help minimize the blinding glare of headlamps.

CARGO CAPABILITY ABOUNDS Space to store your items is plentiful: mesh net storage in all the doors, a locking glove compartment for keeping smaller items secure and a lockable centre console with a large bin and inner tray. A bin is located under the rear cargo area floor and features a lift-out tray to safely store door and hardtop bolts. Two-door models feature a removable Fold and Tumble rear bench seat with spring assist that also easily tumbles to make more room for cargo. Unlimited models come standard with a split-folding fold-flat rear seat.



REAR COMPARTMENT COVERED STORAGE.



REMOVABLE CARPETS AND DRAIN PLUGS.



FOLD AND TUMBLE REAR BENCH SEAT.

Properly secure all cargo.



RUBICON SHOWN IN XTREME PURPLE.



RUBICON LEATHER-FACED INTERIOR SHOWN IN BLACK.

RUBICON®

Off-road adventures can take you to a whole new world when you go with Wrangler Rubicon®. Move forward with pride and confidence, knowing Rubicon has been awarded “4x4 of the Decade”⁷⁷ by FOUR WHEELER®. Here, you’re riding in a factory-built warrior from the very start, equipped with Tru-Lok® electronically locking differentials, mud-terrain tires, Rock-Trac® heavy-duty part-time 4x4 system, 4:1 low-gear ratio and rock rails. A 73.1:1 crawl ratio with the 6-speed manual transmission lets you climb at a controlled 0.8 km/h. The performance-tuned suspension includes gas-charged shocks and an electronic sway bar disconnect.

THE BRAWN TO GO EVERYWHERE Muscular 32-inch BFGoodrich® Mud-Terrain tires are mounted on 17-inch polished aluminum wheels with Mineral Grey painted pockets. Skid plate protection helps the mighty Rubicon’s Rock-Trac transfer case gain trail-ready status. Rock rails work to protect Rubicon from damaging debris.

BEST-IN-CLASS WATER FORDING⁸ Thanks to Rubicon’s Trail Rated® water-fording⁹ capabilities, you’ll have no fear crossing streams and large puddles of up to 76 cm (30 in) in depth⁹.

THE FEELING OF FRESH FREEDOM Experience plenty of sunlight and wind in your hair with the available Dual Top Group. It includes a Black Spackle three-piece Freedom Top® hardtop and premium Black Sunrider® Soft Top. If you want to coordinate your style, match the colour of your hardtop and fender flares to your exterior paint.



“4x4 OF THE DECADE”⁷⁷
FOUR WHEELER®

RUBICON® SHOWN IN HYPERGREEN.



WILLYS WHEELER SHOWN IN FIRECRACKER RED.

SAHARA®

Your desire to match style and comfort with authentic Jeep® brand capability is satisfied with Wrangler Sahara.® Standard equipment includes Black tubular side steps, body-colour fender flares, body-colour front and rear bumper inserts, bright grille and headlamp accents, and a Black Spackle Jeep Freedom Top® hardtop. Gas-charged shocks deliver a smooth ride on the road ahead. Give Sahara the full open-air treatment by removing the doors and the top, and even folding down the windshield!³ Convenient automatic headlamps and attention-grabbing 18-inch polished aluminum wheels with Granite Crystal painted pockets complete the look.

WILLYS WHEELER

Master off-road challenges like a natural-born hero, thanks to standard features that include a Dana® 44 heavy-duty rear axle, anti-spin differential, beefy off-road BFGoodrich® tires and rock rails. Its burly Command-Trac™ part-time shift-on-the-fly 4x4 system forges through tough terrain with a 2.72:1 low-range gear ratio. Willys Wheeler is designed to impress, with its Gloss Black grille and front and rear bumper appliques, performance suspension and 17-inch High-Gloss Black aluminum wheels. The original, revered WWII Willys is given due respect with the “Willys” hood decal. Willys Wheeler models offer a variety of standard creature comforts, including hands-free communication⁹ with Bluetooth® streaming audio, SiriusXM satellite radio with one-year subscription¹² and an Electronic Vehicle Information Centre (EVIC).

SPORT

Go to places others only dream of reaching. Get behind the wheel of Wrangler Sport and you'll command the torque to tackle every challenge with Canada's Best-Selling engine², the 3.6L Pentastar™ Variable Valve Timing (VVT) V6, matched to the legendary Command-Trac part-time shift-on-the-fly 4x4 system. This combination will go virtually anywhere it's directed. The five-link suspension adds comfort to the daily commute. The standard Sunrider® Soft Top sends plenty of fresh air your way, and a steering wheel with audio and cruise controls adds to Sport's functionality.



SPORT SHOWN IN FIRECRACKER RED.



SAHARA UNLIMITED SHOWN IN CHIEF. 11



SAHARA® UNLIMITED SHOWN IN GRANITE CRYSTAL METALLIC.



SAHARA UNLIMITED SHOWN IN GRANITE CRYSTAL METALLIC.

BEST-IN-CLASS HORSEPOWER⁶

CANADA'S BEST-SELLING ENGINE² — THE 3.6L PENTASTAR™ VARIABLE VALVE TIMING (VVT) V6 Move to the front of the class. The award-winning Pentastar™ engine with VVT performs like a hero with 260 lb-ft of torque and a Best-in-Class 285 horsepower.⁶ This efficient powerhouse is built to take you and your Wrangler on a legendary journey anywhere you want to roam.

UNSURPASSED TOWING CAPABILITY³

BRING ALONG MORE FUN The 3.6L Pentastar V6 engine comes standard with an exceptionally capable 6-speed manual, or you can opt for the smooth-shifting 5-speed automatic. The strategically optimized automatic transmission helps maximize fuel economy while its low first-gear ratio gives Wrangler authentic Jeep® Trail Rated® off-road capability via a lower overall crawl ratio. You have plenty of power to bring your favourite toys with you as well, thanks to Wrangler's unsurpassed towing capability of up to 3,500 lb (1,588 kg).³

UNSURPASSED
TOWING CAPABILITY³
UP TO 3,500 LB (1,588 KG)



SAHARA® UNLIMITED SHOWN IN FIRECRACKER RED.



SEE MORE OF EVERYTHING

The world is a big place. Wrangler lets you take it all in. Remove the doors, fold down the windshield,¹³ open the Sunrider® Soft Top and live large. Enjoy life from a point of view that removes all boundaries between you and the great outdoors.

FREEDOM TOP® HARDTOP is strong and secure. This option has a three-piece modular design that lets you bring in the sun as you see fit. Standard on Sahara® and 75th Anniversary Edition, optional on Sport, Willys Wheeler and Rubicon®. The Freedom Top® hardtop is offered in a Black Spackle coat on all models or matched to the exterior paint colour of your Wrangler Sahara, 75th Anniversary Edition or Rubicon.



SUNRIDER® SOFT TOP utilizes special three-ply material that is standard and quiet, watertight and easy to fold away.

PREMIUM SUNRIDER SOFT TOP adds durability and sound dampening for a quieter ride, making it an attractive available option. Plus, a dust blocker helps keep it in tip-top shape and makes it easier to wash.

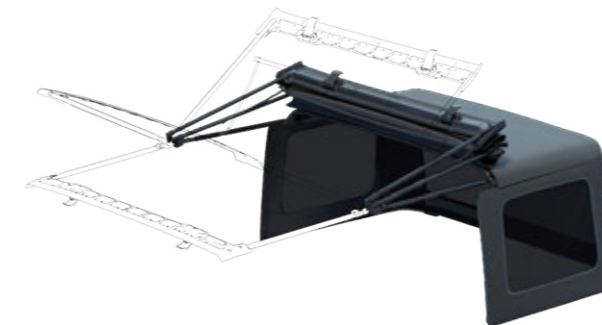

THE VIEW FROM THERE

NEW LED HEADLIGHTS AND FOG LAMPS Project light far onto the road for a clear view of your surroundings and let Wrangler's LED lights guide your way. Available with the LED Lighting Group, these headlamps shine bright in the night, giving everyone a heads-up that you're sharing the road, adding safety and security to your nighttime rides.

SIDE STEPS AND ROCK RAILS Make it easier for you and your passengers to gain entry into your Wrangler. Add the available convenience of side steps to easily get into your next adventure. Upgrade to rock rails for added style and protection against road debris, mud and all the things Mother Nature can throw at you.

CONNECT AND MOVE FORWARD TOGETHER

Uconnect® systems are designed with user-friendly technology that allows you to stay connected – without losing focus on the road. It's a digital world out there, and with Uconnect, you can select the system that best suits your needs and lifestyle. With so many convenient options to choose from, discover how you would like to connect at driveuconnect.ca.



SIMPLY INTUITIVE Uconnect multimedia centres bring a range of available communication and entertainment services straight into your vehicle. An available nine-speaker Alpine® premium sound system including subwoofer makes you feel as if you're sitting front and centre at a concert hall. Get turn-by-turn directions with available navigation¹¹ so you don't get lost along the way (unless you want to).



PHONE Available Uconnect hands-free communication⁹ is the in-vehicle, voice-activated calling system that allows you to talk on your Bluetooth®-compatible phone virtually hands-free. This clever system is also smart enough to synchronize with your Bluetooth-compatible phone's address book¹⁴ – up to 1,000 entries – every time you get into your vehicle. It will announce and read incoming text messages¹⁰ and it also allows you to reply by selecting any of the predefined responses.



VOICE COMMAND⁹ It simplifies driving by letting you keep your eyes on the road and your hands on the wheel. Use your voice to select AM/FM radio stations or available SiriusXM satellite radio¹² channels, as well as adjust cabin temperature and more. You can also select destination entries on your available navigation.¹¹ This available "smart" system technology can be trained to better recognize your voice, ensuring you keep your eyes on the road and hands on the wheel.



ENTERTAINMENT You'll have several ways to access audio. Get the sound going via a remote USB port, an auxiliary audio input jack and Bluetooth streaming audio. Listen to over 120 channels on the available SiriusXM satellite radio¹² and enjoy instant replays of your favourite tunes, access any channel playing your favourite artists, get alerts when your favourite teams are playing and so much more.



ALWAYS PLAY IT SAFE

SAFETY AND SECURITY

HEATED POWER EXTERIOR MIRRORS Melt snow and ice off these available sideview mirrors as you warm up your interior, and keep your mirrors free of ice as you drive.

SPORT BAR High-strength steel is integrated into the B-pillar that runs into the floor, helping to improve side-impact performance and vehicle stiffness on every Wrangler.

SENTRY KEY® ANTITHEFT ENGINE IMMOBILIZER A unique embedded key code matched only to your vehicle. This standard feature helps keep your Wrangler safely where it belongs.

ENERGY-ABSORBING FRONT RAIL EXTENSIONS Collapsible, hydroformed front rail tips provide Wrangler with low-speed protection and can be serviced after impact events of up to 13 km/h.

ENHANCED ACCIDENT RESPONSE SYSTEM (EARS) This standard system makes it easier for emergency personnel to see and reach occupants in the event of an accident by turning on interior lighting, flashing hazard lamps and unlocking doors after air bag¹⁵ deployment. It also shuts off the flow of fuel to the engine once the vehicle comes to a stop.



ELECTRONIC STABILITY CONTROL (ESC)¹⁶

Every Wrangler arrives with this advanced system designed to assist drivers in maintaining control of their vehicle. It utilizes hydraulic Brake Assist, Traction Control, Electronic Roll Mitigation and Trailer Sway Control to constantly monitor driver input against the vehicle's actual course. ESC has three modes: Full-On, Partial-On (shuts off traction control) and Full-Off (ideal for off-road driving).



AIR BAGS¹⁵

The standard advanced multistage front air bags provide nearly instantaneous occupant protection by matching air bag output to crash severity. Available supplemental front-seat-mounted side air bags deploy from the outboard side of each front seat to enhance protection of the driver and front passenger in certain impacts.

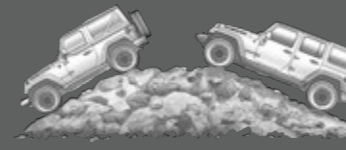

HILL START ASSIST (HSA) HILL DESCENT CONTROL (HDC)

HSA works to prevent all Wranglers from rolling when starting on an up- or downhill gradient. It holds the vehicle stationary for two seconds after the driver's foot is removed from the brake pedal, allowing time to apply the throttle. **HDC** is packaged with the available 5-speed automatic transmission and diligently works to help Wrangler navigate steep declines safely, at a consistent speed.



SAHARA® UNLIMITED SHOWN IN BRIGHT WHITE.



SPORT BAR WITH NINE-SPEAKER ALPINE® PREMIUM SOUND SYSTEM. 17

WRANGLER FEATURES AND OPTIONS

SPORT



POWERTRAIN

- 3.6L Pentastar™ Variable Valve Timing (VVT) V6 with 5-speed automatic
- 3.6L Pentastar VVT V6 with 6-speed manual

INTERIOR AMENITIES

- 12-volt auxiliary power outlet
- Cloth seating with driver's height-adjustable seat
- Easy-access folding front-passenger seat
- Fold and Tumble rear bench seat
- Front floor mats and cargo compartment floor mat
- Front seatback map pockets and full-length floor console
- Radio 130 multimedia centre with 8 speakers
- Rear compartment covered storage
- Steering wheel-mounted audio and cruise controls
- Temperature and compass display
- Wash-out interior with removable carpets and drain plugs

EXTERIOR FEATURES

- 16-inch slot-spoke styled steel wheels
- Black fender flares and bumpers
- Black Sunrider® Soft Top
- Fog lamps
- Full-metal doors with manual windows and door locks
- Halogen headlamps
- Manual foldaway mirrors

- Matching full-size spare tire, exterior-mounted
- P225/75R16 BSW on-/off-road tires
- Tinted windshield and front-door glass

SAFETY & SECURITY

- 4-wheel disc brakes
- Advanced multistage driver and front-passenger air bags¹⁵
- Cargo tie-down loops
- Electronic Stability Control (ESC)¹⁶ with Hill Start Assist, Traction Control, Electronic Roll Mitigation and Trailer Sway Control
- Fuel tank and transfer case skid plates
- Hill Descent Control (5-speed automatic)
- Sentry Key® anti-theft engine immobilizer
- Tire pressure monitoring warning lamp
- Tow hooks – 2 front and 1 rear

CAPABILITY & FUNCTIONALITY

- 3.21 rear axle ratio
- 160-amp alternator
- Command-Trac™ part-time, shift-on-the-fly 4x4 system
- Dana® 44 heavy-duty rear axle and Dana 30 solid front axle
- Engine block heater
- Front and rear stabilizer bars
- Torx® tool kit

OPTIONAL EQUIPMENT

- 3.73 Rear Axle Ratio
- 16-inch Black Wheels
- 17-inch Moab Sparkle Silver Aluminum Wheels
- Air Conditioning
- Alpine® Premium Audio System with 9 Speakers including Subwoofer
- Connectivity Group
- Half-Metal Doors with Manual Locks
- Jeep Freedom Top® Hardtop, Black Spackle
- Jeep Freedom Top Hardtop Headliner
- LED Lighting Group
- Mopar® Black Appearance Group
- Mopar Chrome Edition Group
- Mopar Premium Chrome Group
- Mopar Slush Mats
- Premium Black Sunrider Soft Top
- Radio 430 Multimedia Centre with 6.5-inch Touchscreen
- SiriusXM Satellite Radio with 1-Year Subscription¹²
- Trailer Tow Group
- Tubular Side Steps

SAHARA®



POWERTRAIN

- 3.6L Pentastar™ Variable Valve Timing (VVT) V6 with 5-speed automatic
- 3.6L Pentastar VVT V6 with 6-speed manual

ENHANCEMENTS vs SPORT S

- 18-inch polished aluminum wheels with Granite Crystal painted pockets
- 115V auxiliary power outlet
- Air conditioning
- Auto-dimming rearview mirror with reading lamp
- Automatic headlamps
- Black, power, heated mirrors, manual folding
- Body-colour fender flares and bumper overlay
- Bright bezels, grab handles and vent rings
- Bright grille and headlamp accents
- Heavy-duty suspension with gas shocks
- Jeep® Freedom Top® hardtop, Black Spackle

- P255/70R18 OWL on-/off-road tires
- Power locks and front windows, 1-touch down
- Radio 430N multimedia centre with 6.5-inch touchscreen and navigation¹¹
- Remote keyless entry
- Remote start (5-speed automatic)
- Security alarm
- SiriusXM satellite radio with 1-year subscription¹²
- Tubular side steps

OPTIONAL EQUIPMENT

- 3.73 Rear Axle Ratio
- 18-inch 7-Spoke Polished Aluminum Wheels
- Air Conditioning with Automatic Temperature Control (ATC)
- Alpine® Premium Audio System with 9 Speakers including Subwoofer
- Anti-Spin Differential Rear Axle
- Body-Colour Jeep Freedom Top Hardtop
- Connectivity Group
- Dual Top Group
- Heated Front Seats
- Jeep Freedom Top Hardtop Headliner
- Jeep Trail Rated® Kit
- Leather-Faced Seats
- LED Lighting Group
- Max Tow Package (Unlimited)
- Mopar® Chrome Edition Group
- Mopar Premium Chrome Group
- Mopar Premium Sound and Leather Group
- Mopar Slush Mats
- Premium Black Sunrider® Soft Top
- Supplemental Front-Seat-Mounted Side Air Bags¹⁵
- Trailer Tow Group

SPORT S



POWERTRAIN

- 3.6L Pentastar VVT V6 with 5-speed automatic
- 3.6L Pentastar VVT V6 with 6-speed manual

ENHANCEMENTS vs SPORT

- 17-inch Moab Sparkle Silver aluminum wheels
- Air conditioning (2-door)
- Chrome/leather-wrapped shift knob
- Deep-tint sunscreen glass
- Leather-wrapped steering wheel
- P255/75R17 OWL on-/off-road tires
- Rear 60/40 split-folding seat (Unlimited)
- Rear dome lamp (Unlimited)
- Rear floor mats (Unlimited)
- SiriusXM satellite radio with 1-year subscription¹² (2-door)

OPTIONAL EQUIPMENT

- 32-inch Tire and Wheel Group (2-door)
- 3.73 Rear Axle Ratio
- Air Conditioning (Unlimited)
- Alpine Premium Audio System with 9 Speakers including Subwoofer
- Anti-Spin Differential Rear Axle
- Cold Weather Group
- Connectivity Group
- Dual Top Group
- Half-Metal Doors with Manual Locks
- Jeep Freedom Top Hardtop, Black Spackle
- Jeep Freedom Top Hardtop Headliner
- LED Lighting Group
- Max Tow Package (Unlimited)
- Mopar Black Appearance Group
- Mopar Chrome Edition Group
- Mopar Premium Chrome Group
- Mopar Premium Sound and Leather Group
- Mopar Slush Mats
- Power Convenience Group
- Premium Black Sunrider Soft Top
- Radio 430 Multimedia Centre with 6.5-inch Touchscreen
- SiriusXM Satellite Radio with 1-Year Subscription¹² (Unlimited)
- Supplemental Front-Seat-Mounted Side Air Bags¹⁵
- Trailer Tow Group
- Tubular Side Steps

75TH ANNIVERSARY EDITION†



POWERTRAIN

- 3.6L Pentastar VVT V6 with 5-speed automatic
- 3.6L Pentastar VVT V6 with 6-speed manual

ENHANCEMENTS vs SAHARA

- 17-inch Low-Gloss Bronze aluminum wheels
- Anti-spin differential rear axle
- Body-colour grille with Bronze accents
- Bronze headlamp accents
- Bronze Jeep grille badge
- Bronze painted front and rear bumpers
- Bronze Rubicon® rock rails
- Bronze tow hooks – 2 front and 1 rear
- Electronic Vehicle Information Centre
- Hands-free communication with Bluetooth® streaming audio⁹
- Heated front seats
- Leather-faced seats with Ombré mesh inserts

- Mopar slush mats
- Moroccan Sun instrument-panel bezels
- Moroccan Sun interior accents
- P245/75R17 OWL on-/off-road tires
- Power dome hood
- Radio 430 multimedia centre with 6.5-inch touchscreen
- Remote USB Port
- Tire pressure monitoring display

OPTIONAL EQUIPMENT

- Air Conditioning with ATC
- Alpine Premium Audio System with 9 Speakers including Subwoofer
- Body-Colour Jeep Freedom Top Hardtop
- Dual Top Group
- Jeep Freedom Top Hardtop Headliner
- Jeep Trail Rated Kit
- LED Lighting Group

- Premium Black Sunrider Soft Top
- Radio 430N Multimedia Centre with 6.5-inch Touchscreen and Navigation¹¹
- Supplemental Front-Seat-Mounted Side Air Bags¹⁵
- Trailer Tow Group

[†]Limited availability.

WILLYS WHEELER



POWERTRAIN

- 3.6L Pentastar VVT V6 with 5-speed automatic
- 3.6L Pentastar VVT V6 with 6-speed manual

ENHANCEMENTS vs SPORT S

- 3.73 rear axle ratio
- 17-inch High-Gloss Black aluminum wheels
- Air conditioning (2-door)
- Anti-spin differential rear axle
- Black Jeep grille badge
- Black, power, heated mirrors, manual folding
- Electronic Vehicle Information Centre (EVIC)
- Gloss Black grille, and front and rear bumper appliqués
- Hands-free communication with Bluetooth® streaming audio⁹
- Low-Gloss Black Wrangler decal
- LT255/75R17 BSW off-road BFGoodrich® tires
- Mopar Jeep Trail Rated® Kit

- Mopar slush mats
- Performance suspension
- Power locks and front windows, 1-touch down (Unlimited)
- Remote keyless entry (Unlimited)
- Rock rails
- Security alarm (Unlimited)
- SiriusXM satellite radio with 1-year subscription¹²
- Tire pressure monitoring display
- Willys hood decal

OPTIONAL EQUIPMENT

- Air Conditioning (Unlimited)
- Alpine Premium Audio System with 9 Speakers including Subwoofer
- Dual Top Group
- Half-Metal Doors with Manual Locks
- Jeep Freedom Top Hardtop, Black Spackle
- Jeep Freedom Top Hardtop Headliner

- LED Lighting Group
- Max Tow Package (Unlimited)
- Power Convenience Group
- Premium Black Sunrider Soft Top
- Radio 430 Multimedia Centre with 6.5-inch Touchscreen
- Supplemental Front-Seat-Mounted Side Air Bags¹⁵
- Trailer Tow Group
- Tubular Side Steps

RUBICON



POWERTRAIN

- 3.6L Pentastar VVT V6 with 5-speed automatic
- 3.6L Pentastar VVT V6 with 6-speed manual

ENHANCEMENTS vs SAHARA

- 4.10 rear axle ratio
- 17-inch polished aluminum wheels with Mineral Grey painted centre
- Black front and rear bumpers and fender flares
- Body-colour grille and headlamp accents
- Dana® 44 heavy-duty front axle
- Electronic front sway bar disconnect
- LT255/75R17 BSW off-road BFGoodrich® tires
- Performance suspension

- Premium Black Sunrider Soft Top
- Rock rails
- Rock-Trac® heavy-duty part-time 4x4 system
- Tru-Lok® front and rear axle

OPTIONAL EQUIPMENT

- Air Conditioning with ATC
- Alpine Premium Audio System with 9 Speakers including Subwoofer
- Body-Colour Fender Flares
- Body-Colour Jeep Freedom Top Hardtop
- Cold Weather Group
- Connectivity Group
- Dual Top Group
- Heated Front Seats

- Jeep Freedom Top Hardtop, Black Spackle
- Jeep Freedom Top Hardtop Headliner
- Jeep Trail Rated Kit
- Leather-Faced Seats
- LED Lighting Group
- Max Tow Package (Unlimited)
- Mopar Premium Chrome Group
- Mopar Premium Sound and Leather Group
- Mopar Slush Mats
- Supplemental Front-Seat-Mounted Side Air Bags¹⁵
- Trailer Tow Group (2-door)

FABRIC, PAINT[†] AND WHEEL OPTIONS

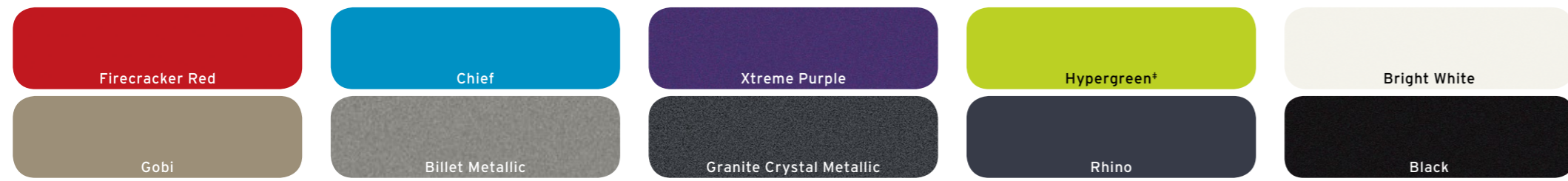
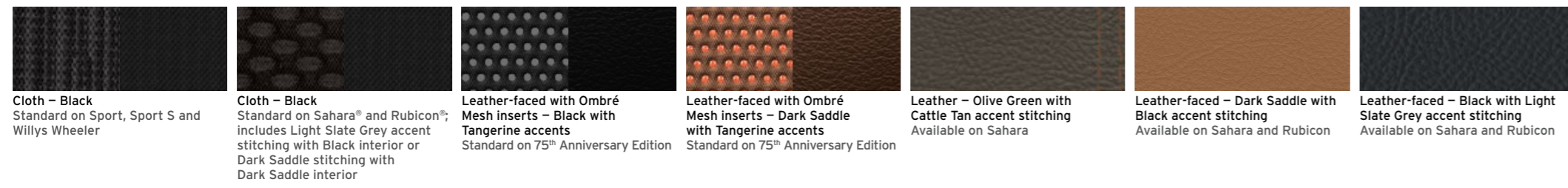

[†]Colours may not be available on all models, and may be limited/restricted. Please see your retailer for details. ^{††}Limited availability.



PACKAGE DETAILS AND MULTIMEDIA CENTRES

32-INCH TIRE AND WHEEL GROUP

- 17-inch polished aluminum wheels with Mineral Grey painted centre
- LT255/75R17 BSW off-road BFGoodrich® tires
- Performance suspension

ALPINE® PREMIUM AUDIO SYSTEM

- 9 speakers with all-weather subwoofer
- 552-watt amplifier

COLD WEATHER GROUP

- Auto-dimming rearview mirror with reading lamp
- Black, power, heated mirrors, manual folding
- Heated front seats
- Heavy-duty suspension (Sport S)
- LT265/70R17C K02 tires (Sport S)
- Mopar® slush mats
- Power locks
- Remote keyless entry
- Remote start system (5-speed automatic)
- Security alarm

CONNECTIVITY GROUP

- Chrome/leather-wrapped shift knob
- Electronic Vehicle Information Centre (EVIC)
- Hands-free communication with Bluetooth® streaming audio⁹
- Leather-wrapped steering wheel
- Remote USB port
- Tire pressure monitoring display

LEATHER-FACED SEATS

- Front seatback map pockets
- Heated front seats

LED LIGHTING GROUP

- Automatic headlamps
- LED fog lamps
- LED reflector headlamps

MAX TOW PACKAGE

- 3.73 rear axle ratio (Sport Unlimited, Sahara Unlimited and Willys Wheeler Unlimited)
- 4-pin wiring harness
- Class II hitch receiver

MOPAR® BLACK APPEARANCE GROUP

- Mopar Black fuel filler door with chrome screws
- Mopar Black taillamp guards
- Mopar Black tubular side steps

MOPAR CHROME EDITION GROUP

- Mopar Chrome exhaust tip
- Mopar Chrome fuel filler door
- Mopar Chrome taillamp guards
- Mopar Chrome tubular side steps

MOPAR PREMIUM CHROME GROUP

- Mopar Chrome exterior mirrors
- Mopar Chrome grille

MOPAR PREMIUM SOUND AND LEATHER GROUP

- 115-volt auxiliary power outlet
- Alpine® premium audio system with 9 speakers including all-weather subwoofer
- Heated front seats
- Katzkin® leather seating

POWER CONVENIENCE GROUP

- Auto-dimming rearview mirror with reading lamp
- Power, heated mirrors, manual folding
- Power locks
- Power windows, front 1-touch down
- Remote keyless entry
- Security alarm

RADIO 130

- AM/FM/CD
- Auxiliary audio input jack

RADIO 430 (RADIO 130 FEATURES PLUS)

- 6.5-inch touchscreen
- 28GB hard drive
- USB port on radio

RADIO 430N (RADIO 430 FEATURES PLUS)

- Garmin® navigation¹¹

TRAILER TOW GROUP

- 4-pin wiring harness
- Class II hitch receiver

POWER AND FUEL ECONOMY

Based on 2017 *EnerGuide* fuel consumption ratings. Government of Canada test methods used. Your actual fuel consumption will vary based on driving habits and other factors. For *EnerGuide* information, please ask your retailer or visit the Government of Canada Web site: www.vehicles.nrcan.gc.ca

Model	Engine and Transmission		L/100 km (mpg)		Horsepower	Torque (lb-ft)
			City	Highway		
Wrangler	3.6L Pentastar™ VVT V6	6-speed manual	14.2 (20)	11.0 (26)	285	260
		5-speed automatic	14.1 (20)	11.1 (25)		
Wrangler Unlimited	3.6L Pentastar VVT V6	6-speed manual	15.0 (19)	11.4 (25)	285	260
		5-speed automatic	14.7 (19)	11.7 (24)		

TOP OPTIONS

Model	Sunrider® Soft Top	Premium Sunrider Soft Top	Freedom Top® Hardtop – Black Spackle	Freedom Top Hardtop – Body Colour
Sport	S	O	O	
Sport S	S/SD	O/AD	O/SD	
Willys Wheeler	S/SD	O/AD	O/SD	
Sahara® / 75th Anniversary	SD	AD	S/SD	O/AD
Rubicon®		S/SD	SD	AD

S = Standard. O = Stand-alone option. SD = Standard with Dual Top Group option. AD = Available with Dual Top Group option.

SPECIFICATIONS[§]

Curb Weight, kg (lb)	Wrangler			Wrangler Unlimited		
	Sport/Willys Wheeler	Sahara/75 th Anniversary	Rubicon	Sport/Willys Wheeler	Sahara/75 th Anniversary	Rubicon
Manual Transmission	1706 (3760)	1792 (3951)	1862 (4104)	1848 (4075)	1936 (4269)	1957 (4315)
Automatic Transmission	1717 (3785)	1803 (3976)	1873 (4129)	1860 (4100)	1948 (4294)	1969 (4340)
GVWR	Sport/Willys Wheeler	Sahara/75 th Anniversary	Rubicon	Sport/Willys Wheeler	Sahara/75 th Anniversary	Rubicon
GVWR	2223 (4900)	2268 (5000)	2313 (5100)	2449 (5400)	2495 (5500)	2585 (5700)
Towing, kg (lb) (when properly equipped)	Wrangler			Wrangler Unlimited		
Towing Capacity (maximum)	907 (2000)			1588 (3500)		
Exterior, mm (in)	Sport/Willys Wheeler	Sahara/75 th Anniversary	Rubicon	Sport/Willys Wheeler	Sahara/75 th Anniversary	Rubicon
Wheelbase	2423 (95.4)			2946 (116.0)		
Front Track	1572 (61.9)			1572 (61.9)		
Rear Track	1572 (61.9)			1572 (61.9)		
Overall Height	1842 (72.5)			1844 (72.6)		
Overall Width, without Mirrors	1872 (73.7)			1872 (73.7)		
Overall Length (including spare tire)	4173 (164.3)			4697 (184.9)		
Ground Clearance	211 (8.3) / 254 (10.0)	246 (9.7)	254 (10.0)	208 (8.2) / 1254 (10.0)	246 (9.7)	254 (10.0)
Interior, mm (in)	Front		Rear	Front		Rear
Headroom	1049 (41.3)		1024 (40.3)	1049 (41.3)		1026 (40.4)
Legroom	1041 (41.0)		904 (35.6)	1041 (41.0)		945 (37.2)
Hip Room	1412 (55.6)		1135 (44.7)	1412 (55.6)		1440 (56.7)
Shoulder Room	1417 (55.8)		1135 (44.7)	1417 (55.8)		1443 (56.8)
Volumes and Capacities	Wrangler			Wrangler Unlimited		
Cargo, Rear Seat Upright, L (cu ft)	362 (12.8)			892 (31.5)		
Cargo, Rear Seat Folded, L (cu ft)	1600 (56.5)			1999 (70.6)		
Seating Capacity	4			5		
Fuel Tank Capacity, L (imp gal)	70.5 (15.5)			85.0 (18.7)		

[§]Maximum ratings based on properly equipped vehicles.

ABOUT THIS CATALOGUE. Since the time of printing, some of the information you'll find in this catalogue may have been updated. Ask your retailer for details. Some of the equipment shown or described throughout this catalogue is available at extra cost. Specifications, descriptions, illustrative materials and all competitive comparisons contained herein are as accurate as known at the time this publication was approved for printing. FCA Canada Inc. reserves the right to make changes at any time without notice and without incurring obligation. For the price of the model with the equipment you desire or verification of specifications contained herein, see your Chrysler, Jeep, Dodge and Ram retailer. Chrysler, Ram, Dodge, Jeep, the Jeep grille, Wrangler, Sahara, Rubicon, Freedom Top, Go Anywhere, Do Anything, Mopar, Mopar Vehicle Protection, Rock-Trac, Sentry Key, SRT, Trail Rated, Tru-Lok, Uconnect and Willys Wheeler are registered trademarks, and Command-Trac and Pentastar are trademarks of FCA US LLC. ©2017 FCA Canada Inc. All Rights Reserved. Alpine and the Alpine logo are registered trademarks of Alpine Electronics, Inc. Bluetooth is a registered trademark of Bluetooth SIG, Inc. Dana is a registered trademark of Dana Corporation. SiriusXM, the SiriusXM logo, channel names and logos are trademarks of SiriusXM Radio Inc. and are used under licence. All rights reserved. Sunrider is a registered trademark of Bestop, Inc. BFGoodrich is a registered trademark of Goodyear Corporation. Facebook and logo are registered trademarks of Facebook Inc. Cummins is a registered trademark of Cummins, Inc. Katzkin and the Katzkin logo are registered trademarks of Katzkin Leather Interiors, Inc. Garmin and the Garmin logo are registered trademarks of Garmin Ltd. or its subsidiaries and are registered in one or more countries. Goodyear is a registered trademark of The Goodyear Tire & Rubber Company. Bridgestone and any Bridgestone products or service names are trademarks or registered trademarks of Bridgestone Corporation. TORX is a registered trademark of Acument Intellectual Properties, LLC. The Twitter logo is a service mark of Twitter, Inc. Instagram is a registered trademark of Instagram, Inc. FOUR WHEELER is a registered trademark of TEN: THE ENTHUSIAST NETWORK, LLC. All other trademarks, images and logos are property of their respective owners and are displayed in this publication with permission.

MOPAR VEHICLE PROTECTION. FCA Canada Inc. has a vested interest in your satisfaction and owner experience with your new vehicle. Mopar Vehicle Protection offers extended service and maintenance plans to help ensure you'll enjoy your vehicle for many years down the road – for just pennies a day. For more information on comprehensive vehicle coverage, see your local Chrysler, Jeep, Dodge and Ram retailer or call (800) 465-2001.

WARRANTIES. 2017 Chrysler, Jeep, Dodge and Ram vehicles are backed by a 5-year or 100,000-kilometre fully transferable Powertrain Limited Warranty* with \$0 deductible plus 24-hour roadside assistance¹. SRT vehicles are backed by a 3-year or 60,000-kilometre fully transferable Powertrain Limited Warranty* with \$0 deductible plus 24-hour roadside assistance. Basic Warranty coverage is for 3 years or 60,000 kilometres and Rust-through coverage on all body sheet metal is for 3 years. The Cummins Turbo Diesel engine is protected by a separate Limited Warranty covering the engine for 5 years or 160,000 kilometres². The EcoDiesel engine is backed by a 5-year or 100,000-kilometre fully transferable Powertrain Limited Warranty* with \$0 deductible plus 24-hour roadside assistance¹.

*Whichever comes first. Some conditions may apply. ¹The 5-Year/100,000-Kilometre Powertrain Limited Warranty does not apply to vehicles sold for certain commercial uses. See your retailer for full details.

DISCLAIMERS. 1) Jeep lineup capability based on approach angle, departure angle, breakover angle, ground clearance and water fording. 2) Based on *IIHS* and *Motor Vehicle* Canadian New Vehicle Total Registration from CYE 2011 – 2015 and CYTD July 2016 for all Cars, Light Duty and Medium/Heavy Duty Trucks. 3) When properly equipped. Based on *WardsAuto* Small Sport Utility segmentation and FCA Internal Compact SUV segmentation including Jeep Compass, Jeep Patriot, Chevrolet Trax, Mitsubishi Outlander Sport, Kia Sportage, Hyundai Tucson and Volkswagen Tiguan. 4) Based on total sales in 2015CY in all SUV segments combined as defined by FCA Canada Inc. 5) Capability based on approach angle, departure angle, breakover angle, ground clearance and water fording. 6) Based on *WardsAuto* Small Sport Utility segmentation and FCA Internal Compact SUV segmentation including Jeep Compass, Jeep Patriot, Chevrolet Trax, Mitsubishi Outlander Sport, Kia Sportage, Hyundai Tucson and Volkswagen Tiguan. 7) Based on 2001 – 2010 model years. 8) Do not attempt water fording unless depth is known to be less than 76 cm (30 inches). Traversing water can cause damage that may not be covered by the new vehicle warranty. Always drive responsibly in approved areas. 9) Driving while distracted can result in loss of vehicle control. Only use mobile phones and other devices, even with voice commands, when it is safe to do so. Voice commands of phone require a Bluetooth-compatible phone. 10) Preset voice to text messaging and incoming text message reading require a MAP-enabled phone. 11) Never program while driving. GPS mapping and available 3D navigation may not be detailed or available in all areas or reflect current road regulations. 12) Requires SiriusXM radio subscriptions governed by SIRIUS terms and conditions available at siriusxm.ca. 13) Be sure to follow all instructions in Owner's Manual for removal of top, doors and lowering of windshield. Driving with doors off and windshield down is for off-road use only. 14) Phone must support Bluetooth Phone Book Access Profile (PBAP). 15) The Advanced Front Air Bags in this vehicle are certified to the federal regulations for Advanced Air Bags. Children 12 years old and younger should always ride buckled up in a rear seat. Infants in rear-facing child restraints should never ride in the front seat of a vehicle with a passenger front air bag. All occupants should always wear their lap and shoulder belts properly. 16) No system can repeal the laws of physics or overcome careless driving actions. Performance is limited by available traction, which snow, ice and other conditions can affect. When the warning lamp flashes, the driver needs to use less throttle and adapt speed and driving behaviour to prevailing road conditions.



Jeep®

jeep.ca

Check us out on:
[instagram.com/jeepcanada](https://www.instagram.com/jeepcanada)



Like us on:
[facebook.com/jeepcanada](https://www.facebook.com/jeepcanada)



Follow us on:
twitter.com/jeepcanada



Sign up for updates at:
jeep.ca



52017C576E

(800) 361-3700