



**Koenigsegg**

THE KOENIGSEGG GEMERA





THE WORLD'S FIRST *MEGA-GT*  
AND KOENIGSEGG'S FIRST *FOR FOUR*

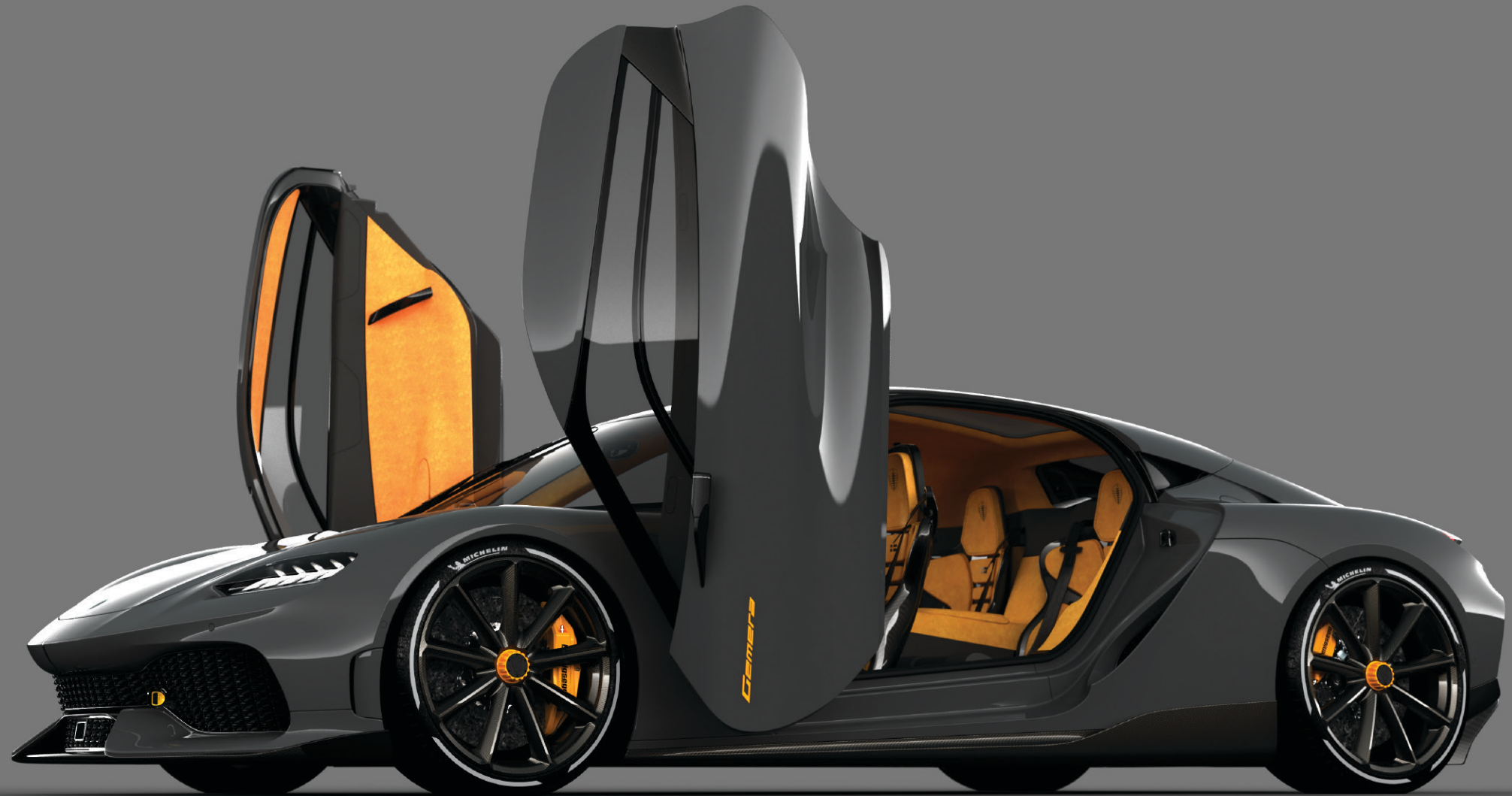



EXTREME MEGACAR MEETS



*SPACIOUS AND PRACTICAL INTERIOR*



## PLUGGED IN TO GO FURTHER

- > New breed of *hybrid*
- > Combined power output of **1700 bhp** or **1.27 MW**
- > **2-liter 3-cylinder dry sump twin turbo engine** called the Tiny Friendly Giant Engine
  - > **800V battery** with up to 50 km of range
  - > **0-100 km/h in 1.9 seconds**, 0-400 km/h in record matching pace
- > **All-wheel steering, all-wheel drive** and **all-wheel torque vectoring**
  - > Koenigsegg Direct Drive; **accelerate 0-400 km/h in one gear**





A CLEAN AND *EXTREME* POWERTRAIN

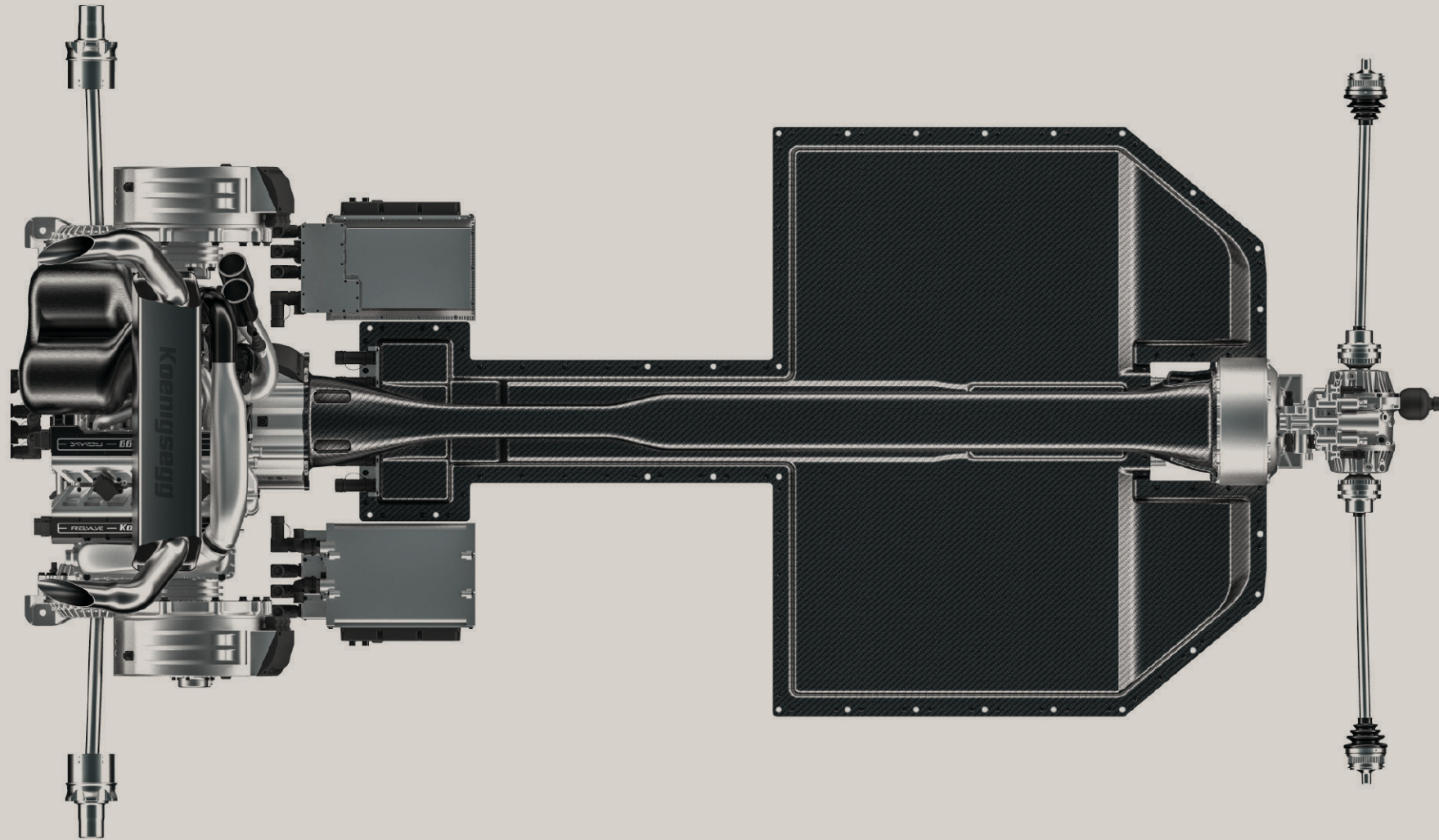

INTRODUCING THE *TINY FRIENDLY GIANT ENGINE*



TOP-MOUNTED AKRAPOVIČ EXHAUSTS LEAVE  
A MASSIVE IMPRESSION ON BOTH LOOKS AND SOUND.

REAR VIEW CAMERAS REPLACE SIDE MIRRORS.





AIR VENTS INCORPORATED INTO THE HEADLIGHTS...

...AND INTO THE TAILLIGHTS.





## PRICE AND TIME PLAN

LIMITED EDITION OF 300 CARS

Start-of-production is planned to 2022, with customer deliveries shortly after.

### PRICE:

**\$1,700,000** excluding taxes, VAT, and registrations fees, but inclusive of freight and federal import duties to agreed location in the USA.







## TECHNICAL SPECIFICATIONS

### PROPULSION

---

#### INTERNAL COMBUSTION ENGINE (ICE)

- Koenigsegg Tiny Friendly Giant Twin Turbo Freevalve 3-cylinder Internal Combustion Engine (ICE) with dry sump lubrication
- Compression: 9.5:1 - Bore: 95 mm - stroke: 93.5 mm
- Closed-loop combustion control with in-cylinder pressure sensing
- 440 kW (600 bhp) at 7500 rpm, red line at 8500 rpm
- Torque: 600 Nm from 2000 rpm to 7000 rpm
- ICE is mounted midship and powers the front axle together with one E-motor through a propshaft
- Engine weight: 70 kg

#### E-MOTORS

- Three Electric Motors: One for each rear wheel with 500 bhp and 1000 Nm each and one E-motor on the crankshaft 400 bhp and 500 Nm to power the front wheels (together with the ICE)

#### ENGINE MANAGEMENT

- Koenigsegg Engine Control Module
- Flex fuel capability including E100, Methanol and sun fuel
- High power ion sensing coil-on-plug ignition system

#### OUTPUT

- Total output 1700 bhp - 3500 Nm, including Hydracoup
- Max wheel torque: 11,000 Nm at ICE 4000 rpm
- 1100 bhp of combined electric power (counting E-motors separately – 1400 bhp)

### RANGE

---

- ICE only range: up to 950 km
- Electric range: up to 50 km
- Total range: up to 1000 km

### TRANSMISSION

---

#### FRONT AXLE

- Midmounted Koenigsegg ICE + E-motor Hydracoup Direct Drive transmission powering the front axle. The front axle has torque vectoring capability and can be disconnected to save energy in EV only mode

#### REAR AXLE

- Independent E-motors with independent transmissions enabling torque vectoring and reverse. The rear transmission are equipped with wet clutches for decoupling, for range mode.

### CHASSIS

---

- Carbon fiber monocoque – wheel to wheel stiffness – 40 KNm
- Front and rear aluminum sub-frames
- Adjustable and lightweight anti-roll bars front and rear
- Robotized hydraulically adjustable ride height front and rear

### BODY

---

- B-pillarless, two doors coupe with fully accessible four-seater interior
- Carbon fiber body panels
- Visible carbon fiber on front and side splitters and venturi
- Carbon fiber wheels (optional)

### HANDLING

---

#### STEERING

- Rack and pinion electric power-assisted steering
- Active rear wheel steering

#### SUSPENSION

- Double wishbones and adjustable gas-hydraulic shock absorbers
- Electronically adjustable ride height

#### ELECTRONIC STABILITY CONTROL

- Koenigsegg Electronic Stability Control (KES)

#### TRACTION CONTROL

- 3 settings: wet – normal – track



## TECHNICAL SPECIFICATIONS

### ASSISTED DRIVING

---

- Autonomous Driving Level 2 ADAS
- Adaptive cruise control
- Lane assist
- Park assist
- Surround-view cameras (helicopter view)

### BRAKES

---

- Front: Ventilated ceramic discs Ø410 mm, 38 mm wide 6-piston
- Rear: Ventilated ceramic discs Ø395 mm, 32 mm wide 4-piston
- Koenigsegg calipers with ceramic pistons
- Electric Brake Booster
- ABS

### WHEELS AND TIRES

---

#### WHEELS

- Koenigsegg third-generation Aircore carbon fiber wheels with center locking (optional)
- Front: 21" x 10.5"
- Rear: 22" x 11.5"

#### TIRES

- Standard: Michelin Pilot Sport 4S
- Optional: Michelin Cup 2 R
- Front: 295/30 ZR21
- Rear: 315/30 ZR22

### DIMENSIONS

---

- Total length: 4975 mm
- Total width: 1988 mm  
(without outer rear-view cameras)
- Total height: 1295 mm
- Wheelbase: 3000 mm
- Fuel capacity: 75 L
- HV Battery: 800 V 16.6 kWh, liquid-cooled
- Dry weight: 1715 kg
- Curb weight: 1850 kg
- Ride Height: 117 mm front, 117 mm rear
- Front lifting system activated: +35 mm
- Total trunk volume (rear and front): 200 L
- Optional roof box

### EQUIPMENT

---

#### SAFETY

- Side, rear view cameras with left and right displays
- Automatic emergency braking
- 6 smart airbags
- Safety belt tensioners
- Rain sensor
- Digital warning and info system, tire pressure monitoring system
- Koenigsegg safety cell with integrated crumple zones
- Two fire extinguishers
- ABS
- Traction control and stability control
- Reversing camera

### COMFORT AND CONVENIENCE

- Luxury interior, with a high degree of customization (leather or Alcantara interior with custom contrast stitching, carbon sport bucket seats with memory foam)
- Four individual heated seats; front seats are four-way electrically adjustable
- Three-zone climate control
- Power windows
- Electric handbrake
- Infotainment system: interior cameras, social media connection, live streaming and digital owner's manual
- 11 speaker plus sub woofer premium sound system
- Front and rear 13" central screens
- Koenigsegg high-end audio with Apple CarPlay
- USB connections
- 2 Inductive phone chargers
- 4 heated and 4 cooled cup holders
- Alarm
- Koenigsegg shield alarm fob
- Car cover, Koenigsegg car charger
- Autoskin electro-hydraulic operation of hoods and doors
- 'Bird's eye' view parking assistance, front and rear parking sensors, proximity protection system for automated door openings

All data is provisional

