

GMC

SIERRA

2015

WE ARE PROFESSIONAL GRADE



2015 GMC SIERRA. To engineer our most advanced pickup ever, we've incorporated some incredible technologies. EcoTec3 engines offer abundant power and impressive efficiency. Inside you'll find an unexpectedly quiet cabin. Settle in and the available Safety Alert Driver Seat uses your sense of touch to make you aware of surrounding vehicles. Discover how these and many other innovations make the 2015 Sierra more than just a truck. It's incredible thinking in the form of a truck.



MODELS | 2

INTERIOR | 10

EXTERIOR | 14

PERFORMANCE | 18

SECURITY | 22

SELECTION | 24



SIERRA CREW CAB SLT IN QUICKSILVER METALLIC (left), SIERRA DENALI CREW CAB IN ONYX BLACK (centre) and SIERRA DOUBLE CAB SLE IN QUICKSILVER METALLIC (right). Vehicles shown with available equipment.

THE SUMMIT. CONSIDER IT ACHIEVED.

At GMC, our designers love details as much as our engineers do. Proof of that is most apparent in Sierra Denali, achieving a level of perfection—and attention—that begins with a purposeful premium design where there is no such thing as a small detail. It takes one look at its appointments to realize that Denali is as well designed as it is well engineered.

EXCLUSIVE 20" CHROME DENALI
WHEELS.

ICONIC DENALI GRILLE.

CHROME 152 MM (6") RECTANGULAR
ASSIST STEPS.

BODY-COLOUR BUMPERS.



SIERRA DENALI CREW CAB IN ONYX BLACK
shown with available equipment.







HEAR HOW QUIET A TRUCK CAN BE.

Sierra is engineered to provide a quiet cabin. Your solitude comes from triple door seals, sound-absorbing materials and an inlaid design that fits the doors precisely into the body. Sierra Denali takes attention to detail a step further with a soft-touch instrument panel, burnished aluminum trim, contrasting stitching and even more appointments.

12-WAY POWER FRONT SEATS.

HEATED AND COOLED PREMIUM
LEATHER-TRIMMED FRONT BUCKET
SEATS.

FRONT AND REAR PARK ASSIST.

HEATED LEATHER-WRAPPED STEERING
WHEEL.



QUIET INSIDE BEGINS OUT HERE.

Sierra's purposeful design helps reduce wind noise for a quiet cabin while increasing efficiency. A wind-tunnel-crafted appearance means air is used to help rather than hinder—cooling the engine or otherwise flowing smoothly, and quietly, over Sierra's sculpted surfaces. Sierra SLT surrounds its premium cabin with chrome accents, bold wheels and distinctive lighting.

REMOTE VEHICLE STARTER SYSTEM.

110-VOLT POWER OUTLET.

10-WAY HEATED, LEATHER-APPOINTED FRONT SEATS.

POWER-ADJUSTABLE PEDALS.



Reimagining truck interiors means surrounding you with premium, durable materials in SLT models. It also means that Crew Cabs offer spacious rear leg room, while Double Cabs feature forward-hinged rear doors to make getting into and out of the rear seat easier.



SIERRA ALL-TERRAIN: TRUE TO ITS NAME.

Keep going long after the pavement ends. Sierra with 4x4 and its available All-Terrain Package sees paved roads as a suggestion because it's engineered to conquer challenging terrain. Inside, no matter how rugged the going gets, it's durable, comfortable and supportive.



EXCLUSIVE ALL-TERRAIN CABIN DESIGN

This distinctive interior provides a supportive environment as well as carbon-fibre-inspired accents, unique All-Terrain leather-appointed seating with French seam contrasting red stitching (SLT only), special dark aluminum IP material, Bose® premium audio system (SLT only) and other All-Terrain appointments.

Z71 OFF-ROAD SUSPENSION Featuring monotube Rancho® shocks, the legendary Z71 suspension allows you to go beyond mere sightseeing to truly explore the great outdoors.

AUTOTRAC 4X4 TRANSFER CASE This 4x4 system is ideal when traction conditions are variable. When driving in AUTO, the front axle is engaged and power is sent to the front and rear wheels automatically based on the driving situation.

HIGH-CAPACITY AIR CLEANER With off-road adventures come all sorts of dirt or debris attempting to invade the engine. The cleaner is engineered with a larger filter area that requires changing less often.

BODY-COLOUR GRILLE AND BUMPERS To match the serious off-roading you'll be doing as well as the body colour, All-Terrain features a grille and bumpers to match. Its rugged appearance sets this Sierra apart from the rest.

UNDERBODY SHIELD PROTECTION Venturing off-pavement means encountering just about anything. This shield helps protect vital components under the truck.

ALL-TERRAIN WHEELS Available ultra-bright machined-aluminum wheels with painted accents are shown at left.



WI-FI® THAT KEEPS PACE WITH YOU.

Sierra offers the latest technologies to keep you connected, informed and entertained. New for 2015, Sierra can be equipped with available OnStar 4G LTE.¹ Gain fast Internet speeds by adding an available Wi-Fi hotspot to turn Sierra into a luxury high-tech mobile office. From personalized voice-activated entertainment and navigation to available driver alert safety technologies to Denali's Customizable Driver Display, you're surrounded by everything you need to do your best.

ONSTAR 4G LTE HOTSPOT¹ New available OnStar 4G LTE with built-in Wi-Fi capability (3 months/3 GB, whichever comes first) means a fast Internet connection for Web-enabled devices up to 15 metres (50') around the truck. It's reliably fast, easy to use and handles up to seven devices.²

PERSONALIZED ENTERTAINMENT AND NAVIGATION

Sierra's available 203 mm (8") diagonal LCD centre touch-screen is the perfect display for the available Colour Touch Sound System with IntelliLink³ as well as the available Navigation System.⁴ The screen provides instant information and dynamic response to help you multitask at the worksite.



CUSTOMIZED DRIVER DISPLAY Sierra Denali's reconfigurable gauge cluster allows you to personalize the new 203 mm (8") diagonal colour Driver Information Centre (DIC) for optimal viewing. By choosing from a menu of display themes, you're able to control not only what information you see, but how you see it.

SAFETY ALERT TECHNOLOGIES To help avoid trouble, Sierra is the first full-size pickup to offer the available Driver Alert Package, including Forward Collision Alert, Lane Departure Warning and the Safety Alert Driver Seat. These innovations help provide additional sources of information about the driving environment surrounding your Sierra.

REAR VISION CAMERA The centre screen also serves as your monitor for the camera, standard on most models. Its dynamic grid lines provide the perfect target when backing up or hitching a trailer.

BOSE AUDIO SYSTEM The optional Bose system is engineered to give you the realism and presence of a live performance.

CENTRE PANEL INSTRUMENTATION Access to controls and power sources is centrally located and within easy reach of the driver's seat. This array of switches puts Sierra's important functions at your fingertips.

POWER SUPPLY Depending on the model and options you choose, you'll never be far from a convenient power supply: up to six USB ports;⁵ four auxiliary power outlets and a 110-volt outlet keep first- and second-row passengers connected and powered up.

¹Visit onstar.ca for coverage maps, details and system limitations. Services and connectivity may vary by model and conditions. OnStar with 4G LTE connectivity is available on select vehicle models and in select markets. Customers will be able to access OnStar services only if they accept the OnStar User Terms and Privacy Statement (including software terms). OnStar acts as a link to existing emergency service providers. After the trial period (if applicable), an active OnStar service plan is required. ²Devices must be WPA2 compliant with active OnStar service and data plan. Wi-Fi devices manufactured prior to 2006 may not be compatible. Please consult your device manufacturer for information regarding the WPA2 security protocol and Wi-Fi device compatibility. Vehicle must be started or in accessory mode to access Wi-Fi. Visit onstar.ca for system details and limitations. ³Full functionality requires compatible Bluetooth® and smartphone, and USB connectivity for some devices. Visit intellilink.gmc.gm.ca for more details. ⁴At time of printing, detailed map coverage is available for most major urban areas of the United States and for certain metropolitan areas of Canada (Vancouver, Calgary, Edmonton, Winnipeg, Windsor, London, Toronto, Ottawa, Montreal, Quebec City and Halifax). Coverage is significantly limited outside these areas. ⁵Not compatible with all devices.

OUR ENGINEERS ARE VERY SUPPORTIVE.

Sierra achieves new levels of support and comfort. The seats are engineered for the long haul, while premium materials like available leather-appointed seating and aluminum trim surround you. Convenient and generous storage options abound so everything is at your fingertips.



SLE SURROUNDINGS Sierra SLE doesn't make you sacrifice comfort, technology or convenience. It features new available OnStar 4G LTE¹ with built-in Wi-Fi capability, 203 mm (8") diagonal Colour Touch IntelliLink² radio (also available with navigation,³) Bluetooth⁴, aluminum trim, soft-touch instrument panel, cloth seats and an available centre floor console as well as locking under-seat storage.

PREMIUM MATERIALS On most models, the instrument panel provides a new premium, soft-touch feel, aluminum trim and contrasting stitching that give the interior an overall contemporary appearance.

LASTING COMFORT SEATS Hard work shouldn't describe the seats. In Sierra, they feature a sculpted design and provide lasting comfort with dual-firmness foam. They retain their shape over time, reducing driver and passenger fatigue.

¹Visit onstar.ca for coverage maps, details and system limitations. Services and connectivity may vary by model and conditions. OnStar with 4G LTE connectivity is available on select vehicle models and in select markets. Customers will be able to access OnStar services only if they accept the OnStar User Terms and Privacy Statement (including software terms). OnStar acts as a link to existing emergency service providers. After the trial period (if applicable), an active OnStar service plan is required. ²Full functionality requires compatible Bluetooth and smartphone, and USB connectivity for some devices. Visit intellilink.gmc.gm.ca for more details. ³At time of printing, detailed map coverage is available for most major urban areas of the United States and for certain metropolitan areas of Canada (Vancouver, Calgary, Edmonton, Winnipeg, Windsor, London, Toronto, Ottawa, Montreal, Quebec City and Halifax). Coverage is significantly limited outside these areas. ⁴Not compatible with all devices.



EASY REAR-SEAT ACCESS Enhanced rear-seat comfort and access means nearly 51 mm (2") of additional leg room on Crew Cabs. Getting into and out of the second row in the Double Cab is easier, thanks to forward-hinged rear doors.

HEATED AND COOLED FRONT SEATS The ultimate in all-weather comfort, these available seats are appointed in perforated leather.

HEATED STEERING WHEEL Standard on Denali, the leather-wrapped, heated steering wheel adds warmth whenever you demand it.



GENEROUS STORAGE The available centre floor console maximizes space with a cavernous storage bin large enough for hanging files, a laptop or mobile devices. Pockets on either side of the console and in the door panels offer "grab and go" convenience to help keep everything within reach. There are also twin glove boxes (with a new USB port⁴ in the upper box on select models) to give you and your companions personal storage areas.

POWER FRONT SEATS Get comfortable at the touch of a button with power-adjustable front seats. Driver-seat adjustment is available for 40/20/40 seating with select equipment packages, and power driver and passenger seats are included with all bucket seats on SLE (10-way driver/six-way passenger), SLT (10-way) and Denali (12-way).



CONVENIENT CHARGING An available 110-volt outlet provides first- and second-row passengers with an accessible power boost.

POWER-ADJUSTABLE PEDALS To help drivers of varying sizes sit at a comfortable distance from the steering wheel, adjustable pedals are available on SLE and standard on SLT and Denali.

CLIMATE CONTROL Automatic dual-zone climate control with individual settings for the driver and front-seat passenger is standard on SLT and Denali and available on SLE.



IT CARRIES A LOT OF THOUGHT.

Unlike stamped steel, a roll-formed process is used in Sierra's cargo bed for the same reason it's used in submarine hulls: It allows for a higher-grade steel that's stronger, lighter and more durable. Sierra offers a maximum payload of 1030 kg [2270 lb.].¹ And depending on the cab, a 5'8", 6'6" or 8' cargo box is available.

CARGO BOX INNOVATIONS Simple yet all-too-important elements like standard rail protectors at the top of the box improve damage resistance. And to help reduce turbulence, a rear spoiler is integrated into the top of the tailgate.

¹These maximum payload ratings are intended for comparison purposes only. Before you buy a vehicle or use it to haul people or cargo, carefully review the vehicle loading section of the Owner's Manual and check the carrying capacity of your specific vehicle on the label on the inside of the driver's door jamb. ²Cargo and load capacity limited by weight and distribution.



CORNERSTEP REAR BUMPER Integrated into the corners, the bumper steps make it easy to access the cargo box. The deep tread of the step accommodates large boots, and hand assists on the top of the side rails help give you a boost into the bed.

EZ-LIFT AND LOWER TAILGATE Loading the cargo box takes less effort thanks to an available EZ-Lift and Lower Tailgate.



SPRAY-IN BEDLINER To provide a permanent, nonskid surface, the available (standard on Denali) black liner covers the entire bed below the side rails, including the tailgate, front box top rail and lower tie-down loops.

AEROSPATS Air deflectors are located in front of the rear tires to direct air around the wheel openings to help reduce turbulence and drag. The result is a more efficient driving experience.



MOVABLE TIE-DOWN HOOKS Four patented, load-bearing upper tie-down hooks are standard. Rated at 113 kg (250 lb.)² each, they can be repositioned in several places around the box depending on the cargo being secured.

LED UNDER-RAIL LIGHTS Standard on most models, LED lights are conveniently positioned under each cargo box rail to make it easier to load or unload at night, or when the box is enclosed by a tonneau cover.

FOUR DOORS. TWO CHOICES.

Our designers and engineers work well together. They combined their skills to create two distinct cab options for the 2015 Sierra. Both the Crew and the Double Cabs provide up to six-passenger seating and easy in-and-out rear-seat access with the addition of traditional forward-hinged rear doors. This was accomplished without enlarging the cabin or adding extra weight.

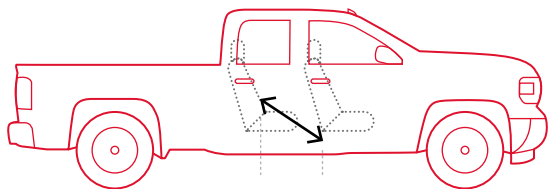

DOUBLE CAB The Sierra Double Cab features forward-hinged rear doors to make it easier to get into and out of the rear seats. Once inside, passengers will benefit from 880 mm (34.6") of leg room. (Double Cab models come with a standard 6'6" cargo bed.)

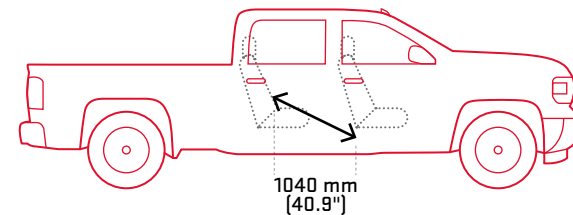

CREW CAB The Sierra Crew Cab, with 1040 mm (40.9") of generous rear-seat leg room, makes for comfortable companions. On both models, the doors and the second-row openings are large to accommodate unobstructed entry and exit. (Crew Cab models come with a standard 5'8" cargo bed or an available 6'6" cargo bed.)



ICONIC GRILLE Sierra Denali's commanding presence is immediately signalled by the unique appearance of its chrome three-dimensional grille.

ENGINEERED AIRFLOW Managing and optimizing airflow is an achievement shared by GMC engineers and designers. The dimensional grille captures a large percentage of air to help cool the engine. Only air necessary for cooling is directed into the engine compartment, while the rest flows smoothly around the truck.

BODY-COLOUR BUMPER Along with a chrome lower fascia, Denali's body-colour front bumper gives Sierra an unmistakable style.

STYLING WITH A PURPOSE Sierra was crafted with the purpose of commanding plenty of attention. This is accomplished with strong, muscular lines and distinctive curves. Even the way the wheel arch mouldings are tightly integrated into the fenders helps protect the finish against chipping from stones and debris.



EXCLUSIVE 20" CHROME WHEELS There's no mistaking these available 10-spoke 20" aluminum wheels. Denali is tastefully cast into the rims.

SIGNATURE LIGHTING In a GMC pickup first, Sierra features projector-beam headlamps fully integrated into the grille surround. The headlamps create a bold, distinctive appearance, further enhanced with available LED signature lighting (standard on All-Terrain, SLT and Denali).



POWERFUL IN THE MOST EFFICIENT WAY.

The Sierra EcoTec3 engines—4.3L V6, 5.3L V8 and 6.2L V8—feature Direct Injection (DI), Active Fuel Management and continuously Variable Valve Timing (VVT) to deliver power and efficiency. No other competitive pickup¹ offers all of these technologies standard in all of its engines. In fact, the available 5.3L V8 generates 355 hp and 10.3 L/100 km hwy (4x2)²

8-SPEED AUTOMATIC TRANSMISSION The available 6.2L V8 is paired with the new Hydra-Matic 8-speed automatic transmission on SLT and Denali models.

DIRECT INJECTION (DI) For precise fuel distribution and fast, efficient combustion, all engines benefit from DI technology.

ACTIVE FUEL MANAGEMENT By sensing load and demand, Active Fuel Management optimizes fuel efficiency by activating or deactivating cylinders (two on the V6 and four on the V8).

JET SPRAY PISTON COOLING To help Sierra engines stay cool under pressure, jets spray oil under pistons and on cylinder walls to help reduce temperatures and maximize power and durability.

¹Comparison based on wardsauto.com 2014 Large Pickup segment and latest competitive information available at time of printing. Excludes other GM vehicles. ²Fuel-consumption ratings based on GM testing in accordance with new 2015 model-year Government of Canada approved test methods. Refer to vehicles.nrcan.gc.ca for details. Your actual fuel consumption may vary.

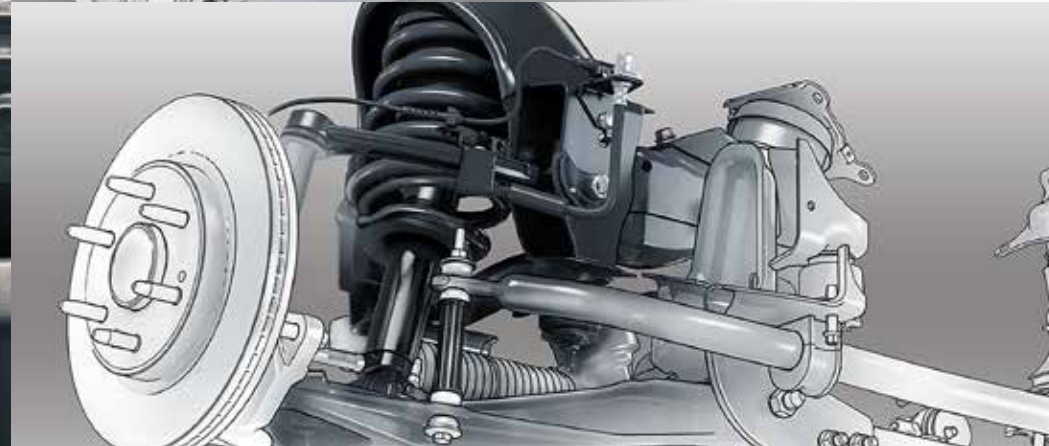
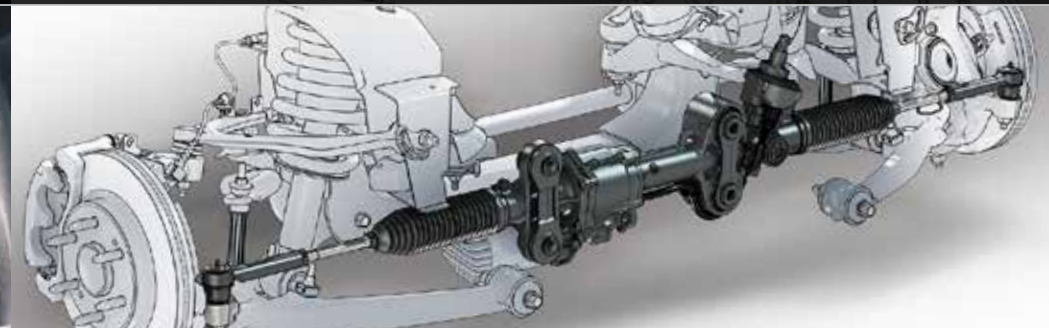

VARIABLE VALVE TIMING (VVT) For responsiveness in low-speed city driving and bold power for open-road passing or trailering, all engines feature continuously VVT.

MAGNETIC RIDE CONTROL For smoothness and refinement rivalling that of premium luxury sedans, Sierra Denali features the remarkable capability of next-generation Magnetic Ride Control. It senses changes in the road surface up to 1000 times per second, instantly adjusting each shock absorber for maximum comfort and control without sacrificing agility.

HYDROFORMED FRAME Providing Sierra with the ultimate in a solid foundation is a hydroformed, fully boxed, high-strength steel frame.

CORROSION-RESISTANT DURALIFE BRAKE ROTORS GMC engineers used patented Ferritic Nitro-Carburizing (FNC) technology that can help double rotor life.

COIL-OVER-SHOCK FRONT SUSPENSION This fully independent system is precisely tuned for improved handling.

HIGH LATERAL-RATE BODY MOUNTS Connecting the body to the frame are high lateral-rate hydraulic and shear-style body mounts. You'll enjoy a smoother, quieter ride.

ELECTRIC RACK-AND-PINION STEERING The electric variable assist power rack-and-pinion steering system on Sierra improves fuel efficiency versus engine-powered systems.

AUTOMATIC LOCKING REAR DIFFERENTIAL This available feature directs power to the wheel with the most traction on loose gravel or slippery surfaces.

STABILITRAK Sierra's electronic stability control system helps improve stability by detecting and reducing traction loss.

LARGE RING GEARS On Sierra 5.3L engine models, the rear axle features a large 241 mm (9.5") ring gear. Choose the Max Trailering Package or a 6.2L model and it increases to 248 mm (9.76"). The rear axles are engineered to handle the robust power and provide durability.



STRENGTH IN NUMBERS: PULLS UP TO 5443 KG (12,000 LB.).¹

The 2015 Sierra is all about strength, enough to achieve an impressive standard V6 engine trailer weight rating of up to 3447 kg (7600 lb.).² On select models with the available 6.2L V8 and Max Trailering Package, it produces a robust trailer weight rating of up to 5443 kg (12,000 lb.),³ based on SAE J2807 performance requirements. And the available 5.3L V8 comes in at 5080 kg (11,200 lb.)⁴ with the Max Trailering Package.

HILL DESCENT CONTROL Activated by pushing a button that's easy to reach, this available feature uses anti-lock braking for a smooth and controlled hill descent in rough terrain without you having to touch the brake pedal.

MAX TRAILERING PACKAGE Increased trailering capacity results when Sierra is equipped with this available feature. It includes 248 mm (9.76") ring gear, 3.73 axle ratio with the 5.3L V8 (3.42 with 6.2L V8), trailer brake controller, enhanced cooling radiator, revised shock tuning and heavier-duty rear springs.

¹Before you buy a vehicle or use it for trailering, carefully review the trailering section of the Owner's Manual. The weight of passengers, cargo and options or accessories may reduce the amount you can tow. ²Requires 4x4 Sierra Regular Cab Standard Box with 4.3L EcoTec3 V6 engine. ³Requires 4x2 Sierra Double Cab or Crew Cab Short Box with available 6.2L EcoTec3 V8 engine and Max Trailering Package. ⁴Requires 4x2 Sierra Double Cab with available 5.3L EcoTec3 V8 engine and Max Trailering Package.



HILL START ASSIST Sensors automatically detect when Sierra is on a 5 percent grade or more. It holds the brakes momentarily or until the accelerator is pressed, preventing rollback.

TOW/HAUL MODE To give you even more power to accelerate when trailering or hauling heavy loads, Tow/Haul mode raises transmission upshift points.

TRAILER SWAY CONTROL Keeps both you and your trailer heading in the same direction, automatically. It detects a swaying trailer, and applies both the vehicle's and the trailer's brakes (if properly equipped) to help bring it back in line.

TRAILER BRAKE CONTROLLER For fingertip control and easy monitoring of your trailer brakes, Sierra offers an available integrated trailer brake controller. It displays the level of brake force or "gain" in the Driver Information Centre.

AUTO GRADE BRAKING It automatically senses when you want to slow your Sierra and engages a Grade Braking shift pattern to help maintain your desired speed.

TAPSHIFT For full command over the truck's shifting, TapShift controls on the shift lever are backed by a patent-pending shift algorithm that improves shift response time.



GIVES YOU A HEADS-UP. BY THE SEAT OF YOUR PANTS.

In an overstimulated world of flashing lights and beeping sounds, Sierra uses your sense of touch to get your attention. It's the first pickup to offer driver alert safety technologies. Safety features are no substitute for the driver's responsibility to operate the vehicle in a safe manner. The driver should remain attentive to traffic, surroundings and road conditions at all times. Read the vehicle Owner's Manual for more important safety information.

¹Air bag inflation can cause severe injury or death to anyone too close to the bag when it deploys. Be sure every occupant is properly restrained. Always use safety belts and the correct restraint for your child's age and size. Even in vehicles equipped with the Passenger Sensing System, children are safer when properly secured in a rear seat in the appropriate infant, child or booster seat. Never place a rear-facing infant restraint in the front seat of any vehicle equipped with an active frontal air bag. See the Owner's Manual and child safety seat instructions for more safety information.

AIR BAGS¹ To help reduce the risk of injury to passengers, dual-stage frontal air bags use sensors to gauge the severity of a crash. Head curtain side-impact air bags deploy from the roof rail like a protective curtain for outboard passengers and can be activated by either rollover sensors or side-impact sensors.

LANE DEPARTURE WARNING This available technology alerts the driver when Sierra drifts over a lane line without signalling while travelling at least 56 km/h (35 mph).

SAFETY ALERT DRIVER SEAT Relaying inputs from Forward Collision Alert and Lane Departure Warning, the available Safety Alert Driver Seat uses a patented warning approach to alert the driver of potential traffic danger using directional vibration pulses within the seat cushion.

FORWARD COLLISION ALERT The available Forward Collision Alert warns you when you're rapidly approaching another vehicle and it appears a collision is imminent.

GMC PRO GRADE PROTECTION.

Pro Grade Protection is standard on every 2015 Sierra. From scheduled maintenance to protecting your vehicle, you can drive with confidence.

2-YEAR/40,000 KM SCHEDULED
LUBE-OIL-FILTER MAINTENANCE PROGRAM²

3-YEAR/60,000 KM NEW-VEHICLE
LIMITED WARRANTY³

5-YEAR/160,000 KM POWERTRAIN
LIMITED WARRANTY³

THERE WHEN YOU NEED US.



Standard for 5 years, the OnStar Basic Plan⁴ helps keep you connected, while the OnStar Directions & Connections Plan, standard for 6 months, lets you speak to a live OnStar Advisor just by pressing the blue OnStar button in your vehicle.

AVAILABLE ONSTAR 4G LTE HOTSPOT⁵ Unleash the full potential of portable devices by allowing you and your companions to play, work, game and surf in your Sierra. A built-in Wi-Fi hotspot (with 3-month/3 GB trial, whichever comes first) enhances your productivity and entertainment.

ONSTAR BASIC PLAN⁴ Stay connected to everyone and everything that matters with the OnStar Basic Plan on 2015 vehicles, including RemoteLink Key Fob Services, to remotely start (if factory equipped) and lock/unlock your car, and activate your horn and lights from anywhere. Plus, get OnStar Vehicle Diagnostics and Dealer Maintenance Notification to make service scheduling simple. If your vehicle has OnStar with 4G LTE,⁵ you have available access to a high-speed Internet connection and in-vehicle Wi-Fi hotspot so you can connect to your favourite Web content. For emergency and Advisor-based services, check out our additional plans.

AUTOMATIC CRASH RESPONSE⁶ In many crashes, built-in sensors can automatically alert an OnStar Advisor who is immediately connected into your vehicle to see if you need help sent to your location—even if you can't respond.

CRISIS ASSIST During severe weather or other crisis situations, OnStar offers assistance to help you connect with loved ones and navigate your way to safety.

EMERGENCY SERVICES If someone in your Sierra needs emergency help, the OnStar emergency button gives you a priority connection to a specially trained Advisor at any time, day or night.

ROADSIDE ASSISTANCE⁷ If you're stranded, run out of gas or have a flat tire, one push of the OnStar button can immediately connect you to an Advisor, ready to help any hour of the day or night.

REMOTE DOOR UNLOCK⁸ If you get locked out of your Sierra, OnStar can help. An OnStar Advisor can send a signal to your Sierra that usually unlocks the doors within minutes.

REMOTE HORN AND LIGHTS Can't remember where you parked? Call the toll-free number and OnStar will send a signal to flash your lights and sound your horn to help you locate your Sierra.

STOLEN VEHICLE ASSISTANCE⁹ If your Sierra is ever stolen, OnStar can help locate it after verification with law enforcement.

HANDS-FREE CALLING¹⁰ WITH VOICE COMMAND This available feature allows you to push a button, call out the number and keep your eyes on the road.

TURN-BY-TURN NAVIGATION All you have to do is push your blue OnStar button and ask the OnStar Advisor to download directions to your Sierra.

ONSTAR eNAV WITH MAPQUEST.CATM Get a head start on a trip by checking out your destination on mapquest.ca. Then just click "Send" and directions will be sent to your Sierra.

DESTINATION DOWNLOAD With the optional Navigation System, simply press your blue OnStar button, and an Advisor will download directions to your Sierra's navigation screen.

²The 2-Year Scheduled Lube-Oil-Filter Maintenance Program provides eligible customers in Canada who have purchased, leased or financed a new eligible 2015 MY GMC vehicle with an ACDelco oil and filter change, in accordance with the Oil Life Monitor system and the Owner's Manual, for 2 years or 40,000 km, whichever occurs first, with a limit of four Lube-Oil-Filter services in total, performed at participating GM dealers. Fluid top-offs, inspections, tire rotations, wheel alignments and balancing, etc. are not covered. This offer may not be redeemed for cash and may not be combined with certain other consumer incentives available on GM vehicles. General Motors of Canada Limited reserves the right to amend or terminate this offer, in whole or in part, at any time without prior notice. Additional conditions and limitations apply. See dealer for details. ³Whichever comes first. See dealer for limited warranty details. ⁴The OnStar Basic Plan is available for 5 years from the date of delivery of the eligible new 2015 model-year vehicle and is transferable. It includes OnStar Vehicle Diagnostics (capabilities vary by model), Dealer Maintenance Notification and access to RemoteLink Key Fob Services (available on select Apple®, Android™, BlackBerry® and Windows® devices). Please visit onstar.ca/mobile for more details. The OnStar Basic Plan does not include any Emergency Services, Automatic Crash Response, Stolen Vehicle Assistance, live Advisor service or Hands-Free Calling. These and other services are available under a paid plan. See OnStar User Terms and Privacy Statement (including software terms) for more details. If you sell your vehicle or wish to cancel use of Basic Plan services, you must contact OnStar at 1-888-4-DNSTAR (1-888-466-7827). ⁵Visit onstar.ca for coverage maps, details and system limitations. Services and connectivity may vary by model and conditions. OnStar with 4G LTE connectivity is available on select vehicle models and in select markets. Customers will be able to access OnStar services only if they accept the OnStar User Terms and Privacy Statement (including software terms). OnStar acts as a link to existing emergency service providers. After trial period (if applicable), an active OnStar service plan is required. ⁶OnStar acts as a link to existing emergency service providers. Not all vehicles may transmit all crash data. ⁷Roadside service provided by Allstate Roadside Services. ⁸Services vary by model and conditions. Requires automatic door locks. ⁹Service varies by model and conditions. Visit onstar.ca for details and system limitations. Stolen Vehicle Slowdown and Remote Ignition Block are available on select 2009 and newer GM vehicles. ¹⁰OnStar Hands-Free Calling requires existing OnStar service plan and prepaid minutes. Not available in certain markets. Calls may be made to the U.S. and Canada only.

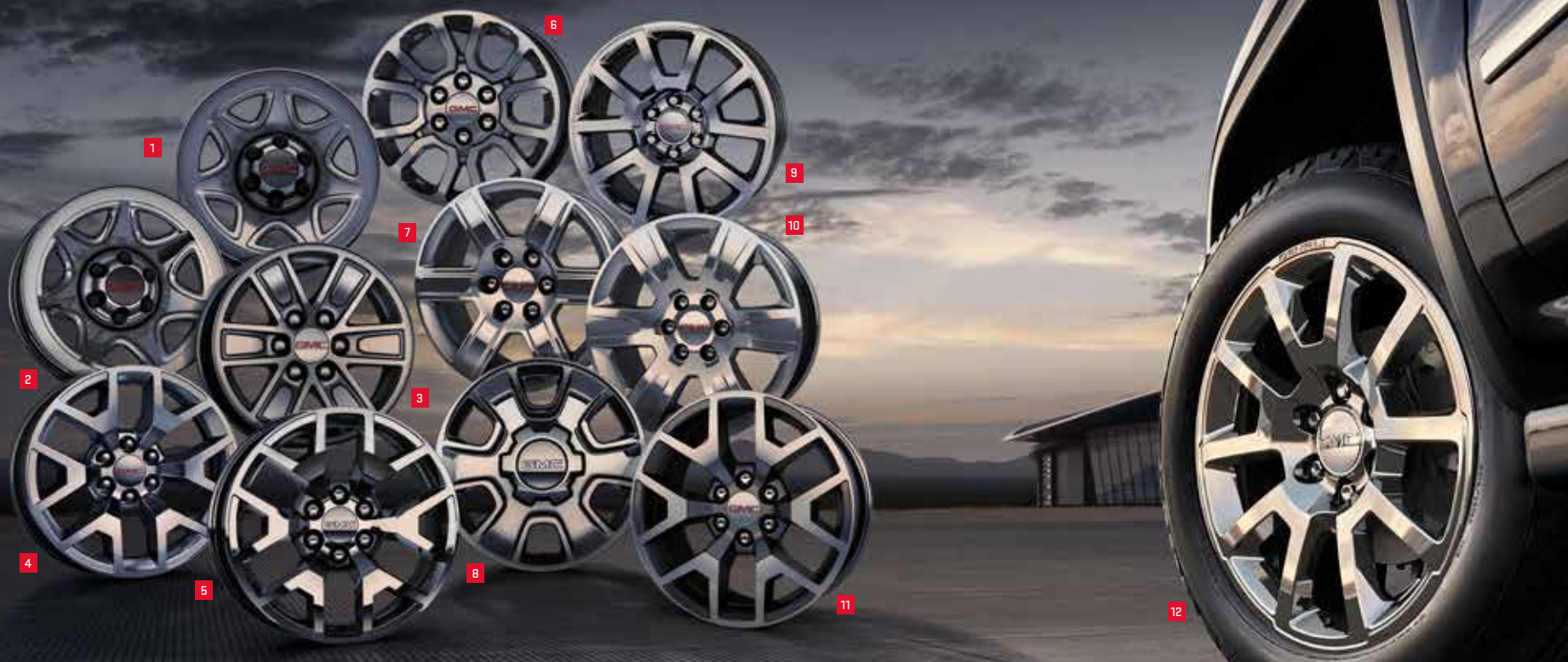

ALL WHEELS ARE ROUND. NOT ALL WHEELS ARE GMC WHEELS.

Building a Professional Grade truck like the 2015 Sierra means engineering every inch of it from the ground up—including the wheels it rides on. That's why you'll find a selection of specifically designed GMC wheels in a range of styles and sizes for your Sierra.

1 17" PAINTED STEEL • RD6
Standard: Sierra

2 17" STAINLESS-STEEL CLAD • RD7
Available: Sierra

3 17" BRIGHT MACHINED • Q5W
Standard: SLE

4 20" POLISHED ALUMINUM • RD5
Available: SLT

5 20" CHROME ALUMINUM • NZM
Available: SLT [early production only]

6 18" BRIGHT MACHINED • UHN
Available: SLE
Included with SLE and SLT All-Terrain [late availability]

7 18" POLISHED ALUMINUM • RCW
Standard: SLT

8 18" CHROME ALUMINUM • RT5
Included with SLE and SLT All-Terrain [early production only]

9 20" MACHINED ALUMINUM • NZG
Standard: Denali [late availability]

10 20" ULTRA-BRIGHT MACHINED • RD3
Available: SLE

11 20" ULTRA-BRIGHT MACHINED ALUMINUM WITH DARK ARGENT PAINTED ACCENTS • NZH
Available: SLE and SLT All-Terrain

12 20" CHROME ALUMINUM WITH DENALI LOGO • RTL
(standard on early production models; available on late production models)
ALSO AVAILABLE ON DENALI IN POLISHED FINISH • NZT
(not shown; late availability)

See your dealer for more wheel and availability details.

GIVE YOUR SIERRA A SINGULAR STYLE.

Engineered to the same Professional Grade standards as your Sierra, GMC Accessories range from functional enhancements like assist steps and bed management systems to stylish wheels and accents.



CHROME FUEL DOOR Add a distinct personality to the exterior of your Sierra with this stylish dealer-installed chrome fuel door.

CHROME TAILGATE HANDLE To help distinguish your Sierra, this good-looking chrome accent handle helps set off the tailgate.

CHROME RECOVERY HOOKS Add functionality and enhance the appearance of your Sierra with chrome recovery hooks. These front hooks are for vehicle recovery only. For more information, see your GMC Owner's Manual.

22" WHEELS Stand out from the crowd with these factory-engineered and -approved wheels from GMC Accessories.¹ All wheels feature a brilliant, durable finish and include matching lugs and GMC logo centre caps.



ALL-WEATHER FLOOR MATS Be prepared for all conditions with these premium all-weather floor mats. Their deep-ribbed pattern collects debris.

SOFT TONNEAU COVER A roll-up soft folding tonneau with integrated crossbows shields cargo and allows full access to the bed. The cover also helps protect the bed itself from debris and harsh weather conditions.



CHROME EXHAUST TIPS These polished exhaust tips add a sporty appearance to your Sierra and feature the GMC logo.

ASSIST STEPS Make it easier to get into and out of your truck with these stylish steps. The 152 mm (6") oval steps are aluminum and the 101 mm (4") round steps are stainless steel. Both are rust-resistant and available in either chrome or black powder coat.



22" 7-Spoke
Silver Wheel (SF1)



22" 6-Spoke
Chrome Wheel (SEZ)



22" 5-Spoke UBM/
Hi Gloss Black Wheel (SEW)



22" 6-Spoke Monoogian Silver
Wheel with UBM (SFO)

¹Use only GM-approved tire and wheel combinations. Unapproved combinations may change the vehicle's performance characteristics. For approved tire and wheel combinations and other important information, go to gm.ca or see your GMC dealer for details.

ACCENTS



Axiom Aluminum



Burnish Aluminum



Mineral Caster Wood Tone



Grand Lace Wood Tone



Curly Wood Tone

INTERIOR COLOURS AND SEATING SURFACES



Jet Black/Jet Black Cloth

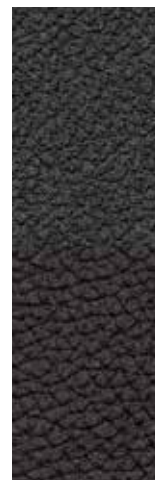

Jet Black/Jet Black Leather-Appointed



Jet Black/Jet Black Perforated Leather-Appointed



Jet Black/Dark Ash Cloth

MODELS

SIERRA	-	-	-	-	-	-	-	-	●
SLE	●	-	● ¹	● ²	-	●	○	-	●
SLT	●	-	● ¹	● ²	-	-	●	○	-
DENALI	-	●	-	-	●	-	-	●	-

KEY ● STANDARD ○ AVAILABLE - NOT AVAILABLE

¹Included with Cocoa/Dune interior only. ²Included with Jet Black and Jet Black/Dark Ash interiors only.

EXTERIOR COLOURS



Stone Blue Metallic^{3,4}

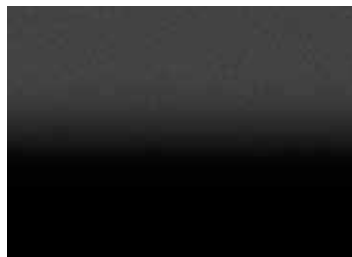

Onyx Black



Quicksilver Metallic^{5,6}



Summit White⁵



Fire Red^{5,6}

³Not available on Sierra trim. ⁴Additional charge, premium paint. See your GMC dealer for more exterior colour details. ⁵Not available on Denali. ⁶Not available with All-Terrain Package. ⁷Crew Cab models only.

ALL-TERRAIN PACKAGE

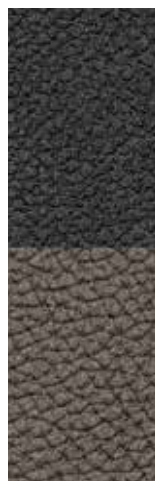

Jet Black/Dark Ash Vinyl

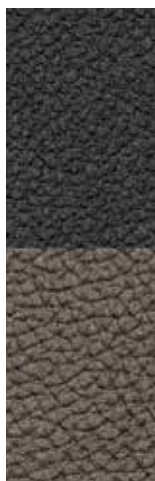

Jet Black/Dark Ash Leather-Appointed



Jet Black/Dark Ash Perforated Leather-Appointed



Cocoa/Dune Cloth

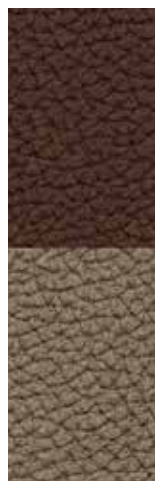

Cocoa/Dune Leather-Appointed



Cocoa/Dune Perforated Leather-Appointed

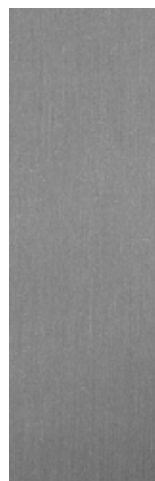

Dark Aluminum



Off-Road Carbon Accent



Jet Black/Jet Black Cloth



Jet Black/Jet Black Leather-Appointed with Cobalt Red Accents

○	-	-	-	-	-	-	-	-	-
-	-	-	●	-	-	○	○	○	-
-	●	○	-	●	○	○	○	-	○
-	-	-	-	-	●	-	-	-	-



Bronze Alloy Metallic⁶



Iridium Metallic



Sonoma Red Metallic



Emerald Green Metallic^{3,4,5,6}



White Diamond Tricoat^{3,4,7}

DIMENSIONS			
CARGO DIMENSIONS, mm (in.)	SHORT BOX	STANDARD BOX	LONG BOX
Cargo Volume, ¹ litres (cu. ft.)	1512 (53.4)	1728 (61.0)	2162 (76.3)
Inside Width at Floor	1296 (51.0)	1296 (51.0)	1296 (51.0)
Box Length at Floor	1761 (69.3)	2004 (78.9)	2484 (97.8)
EXTERIOR DIMENSIONS, mm (in.)	REGULAR CAB	DOUBLE CAB	CREW CAB
Height	1867-1883 (73.5-74.1)	1877 (73.9)	1873-1884 (73.7-74.2)
Overall Length			
Short Box	–	–	5829 (229.5)
Standard Box	5207 (205.0)	5829 (229.5)	6071 (239.0)
Long Box	5687 (223.9)	–	–
WHEELBASE, mm (in.)	REGULAR CAB	DOUBLE CAB	CREW CAB
Short Box	–	–	3645 (143.5)
Standard Box	3023 (119.0)	3645 (143.5)	3886 (153.0)
Long Box	3378 (133.0)	–	–
STANDARD TECHNICAL DATA			
SERIES/DRIVE TYPE	1500 / 4x2	1500 / 4x4	
BRAKES			
All models: Power 4-wheel anti-lock braking system	Front disc/rear disc (w/Duralife rotors)	Front disc/rear disc (w/Duralife rotors)	
STEERING	Electric power rack-and-pinion with variable assist	Electric power rack-and-pinion with variable assist	
FUEL TANK CAPACITY (Approx. litres [imp. gal.]: Short/Standard/Long Box)	98/98/129 22/22/28	98/98/129 22/22/28	
ALTERNATOR (amps)	150	150	
GVWR² (Gross Vehicle Weight Rating), kg (lb.)			
Regular Cab	2948-3084 (6500-6800)	3039-3175 (6700-7000)	
Double Cab	3130-3357 (6900-7400)	3221-3447 (7100-7600)	
Crew Cab	3130-3357 (6900-7400)	3221-3447 (7100-7600)	

SIERRA 1500 SPECIFICATIONS

ENGINES

	EcoTec3 4.3L V6 VVT DI AFM/Aluminum Block (LV3)	EcoTec3 5.3L V8 VVT DI AFM/Aluminum Block (L83)	EcoTec3 6.2L V8 VVT DI AFM Aluminum Block (L86)
CAPACITY	4.3 liters (262 cu. in.)	5.3 liters (325 cu. in.)	6.2 liters (376 cu. in.)
SAE NET HORSEPOWER @ RPM	285@5300	355@5600	420@5600
SAE NET TORQUE @ RPM (LB.-FT.)	305@3900	383@4100	460@4100
ENGINE / MODEL AVAILABILITY			
Regular Cab, Standard Box	●	○	–
Regular Cab, Long Box	●	○	–
Double Cab, Standard Box	●	○	○
Crew Cab, Short Box	●	○	○
Crew Cab, Standard Box	●	○	○
FUEL EFFICIENCY, ³ L/100 km (mpg)			
4x2	13.4 (21) city/9.9 (29) hwy	14.6 (19) city/10.3 (27) hwy	16.1 (18) city/11.4 (25) hwy
4x4	14.1 (20) city/10.6 (27) hwy	14.9 (19) city/10.7 (26) hwy	16.3 (17) city/11.6 (24) hwy
TRANSMISSION	1500: Electronically controlled 6-speed automatic transmission with overdrive, electronic engine grade braking and Tow/Haul mode		
	1500: Electronically controlled 8-speed automatic transmission with overdrive, electronic engine grade braking and Tow/Haul mode (requires 6.2L V8 engine)		

SIERRA 1500 SUSPENSIONS*

FRONT SUSPENSION COIL-OVER-SHOCK

FRONT AXLE/ SPRING CAPACITY, kg (lb.)	4x2 (Short/Standard/Long Box)	4x4
Regular Cab	–/1452/1497 (–/3200/3300)	–/1792/1792 (–/3950/3950)
Double Cab	–/1746/– (–/3850/–)	–/1792/– (–/3950/–)
Crew Cab	1746/1746/– (3850/3850/–)	1792/1792/– (3950/3950/–)

REAR SUSPENSION SEMI-ELLIPTICAL 2-STAGE MULTILEAF SPRINGS

REAR AXLE/ SPRING CAPACITY, kg (lb.)	4x2 (Short/Standard/Long Box)	4x4
Regular Cab	–/1724/1792 (–/3800/3950)	–/1746/1792 (–/3850/3950)
Double Cab	–/1792/– (–/3950/–)	–/1792/– (–/3950/–)
Double Cab w/Max Trailering Package	–/1950/– (–/4300/–)	–/1950/– (–/4300/–)
Crew Cab	1792/1792/– (3950/3950/–)	1792/1792/– (3950/3950/–)
Crew Cab w/Max Trailering Package	1950/1950/– (4300/4300/–)	1950/1950/– (4300/4300/–)

¹Cargo and load capacity limited by weight and distribution. ²When properly equipped; includes weight of vehicle, passengers, cargo and equipment. ³Fuel-consumption ratings based on GM testing in accordance with new 2015 model-year Government of Canada approved test methods. Refer to vehicles.nrcan.gc.ca for details. Your actual fuel consumption may vary. ⁴Capacities and weight ratings are dependent on model, engine, transmission and GVWR combinations. See your GMC dealer for details.

PAYLOAD AND TRAILERING SPECIFICATIONS				
Model	Engine	Axle Ratio	Max Payload ¹ kg (lb.)	Max Conventional Trailering ² kg (lb.)
Regular Cab Standard Box 4x2	4.3L	3.23	885 (1950)	2767 (6100)
	5.3L	3.08	880 (1940)	3175 (7000)
	5.3L	3.42	880 (1940)	4082 (9000)
Regular Cab Standard Box 4x4	4.3L	3.42	871 (1920)	3447 (7600)
	5.3L	3.08	862 (1900)	3039 (6700)
	5.3L	3.42	862 (1900)	3946 (8700)
Regular Cab Long Box 4x2	4.3L	3.23	898 (1980)	2676 (5900)
	5.3L	3.08	898 (1980)	3084 (6800)
	5.3L	3.42	898 (1980)	4445 (9800)
Regular Cab Long Box 4x4	4.3L	3.42	871 (1920)	3357 (7400)
	5.3L	3.08	866 (1910)	2948 (6500)
	5.3L	3.42	866 (1910)	4309 (9500)
Double Cab Standard Box 4x2	4.3L	3.23	848 (1870)	2540 (5600)
	5.3L	3.08	848 (1870)	2948 (6500)
	5.3L	3.42	848 (1870)	4309 (9500)
	5.3L	3.73 ³	1025 (2260)	5080 (11,200) ³
	6.2L	3.23	835 (1840)	4309 (9500)
	6.2L	3.42 ³	966 (2130)	5443 (12,000) ³
Double Cab Standard Box 4x4	4.3L	3.42	839 (1850)	3266 (7200)
	5.3L	3.08	839 (1850)	2812 (6200)
	5.3L	3.42	839 (1850)	4173 (9200)
	5.3L	3.73 ³	1030 (2270)	4990 (11,000) ³
	6.2L	3.23	812 (1790)	4173 (9200)
	6.2L	3.42 ³	957 (2110)	5398 (11,900) ³
Crew Cab Short Box 4x2	4.3L	3.23	816 (1800)	2540 (5600)
	5.3L	3.08	816 (1800)	2903 (6400)
	5.3L	3.42	816 (1800)	4264 (9400)
	5.3L	3.73 ³	989 (2180)	5035 (11,100) ³
	6.2L	3.23	807 (1780)	4264 (9400)
	6.2L	3.42 ³	934 (2060)	5443 (12,000) ³
Crew Cab Short Box 4x4	4.3L	3.42	812 (1790)	3221 (7100)
	5.3L	3.08	826 (1820)	2812 (6200)
	5.3L	3.42	826 (1820)	4173 (9200)
	5.3L	3.73 ³	1002 (2210)	4944 (10,900) ³
	6.2L	3.23	789 (1740)	4173 (9200)
	6.2L	3.42 ³	930 (2050)	5352 (11,800) ³

PAYLOAD AND TRAILERING SPECIFICATIONS <i>continued</i>				
Model	Engine	Axle Ratio	Max Payload ¹ kg (lb.)	Max Conventional Trailering ² kg (lb.)
Crew Cab Standard Box 4x2	4.3L	3.23	776 (1710)	2495 (5500)
	5.3L	3.08	776 (1710)	2903 (6400)
	5.3L	3.42	776 (1710)	4264 (9400)
	5.3L	3.73 ³	948 (2090)	4990 (11,000) ³
	6.2L	3.23	767 (1690)	4218 (9300)
Crew Cab Standard Box 4x4	6.2L	3.42 ³	898 (1980)	5398 (11,900) ³
	4.3L	3.42	776 (1710)	3175 (7000)
Crew Cab Standard Box 4x4	5.3L	3.08	776 (1710)	2767 (6100)
	5.3L	3.42	776 (1710)	4128 (9100)
	5.3L	3.73 ³	953 (2100)	4899 (10,800) ³
	6.2L	3.23	753 (1660)	4128 (9100)
	6.2L	3.42 ³	894 (1970)	5307 (11,700) ³

SIERRA AXLE RATINGS AND PLOW WEIGHTS

FRONT GROSS AXLE WEIGHT RATING (FGAWR) WITH SNOW PLOW PREP PACKAGE (4X4 MODELS ONLY)

BODY	ENGINE	ENGINE TYPE	1500
Regular Cab	4.3L	Gas	1792 (3950)
	5.3L	Gas	1792 (3950)

MAXIMUM PLOW WEIGHTS (4X4 MODELS ONLY)

BODY	ENGINE	ENGINE TYPE	1500
Regular Cab	4.3L	Gas	18/227 (40/500) ⁴
	5.3L	Gas	18/227 (40/500) ⁴

¹These maximum payload ratings are intended for comparison purposes only. Before you buy a vehicle or use it to haul people or cargo, carefully review the vehicle loading section of the Owner's Manual and check the carrying capacity of your specific vehicle on the label on the inside of the driver's door jamb. ²Before you buy a vehicle or use it for trailering, carefully review the trailering section of the Owner's Manual. The weight of passengers, cargo and options or accessories may reduce the amount you can tow. ³Requires 6.2L V8 engine and Max Trailering Package. ⁴45/xxx=45 kg (100/xxx=100 lb.) maximum of permanently attached snow plow mounting hardware/xxx kg [xxx lb.] maximum of removable snow plow blade and blade hardware. Maximum plow weights based on a vehicle with average manufacturer option content and 68 kg (150 lb.) each for driver and one additional front-seat occupant. Additional equipment and occupants will reduce maximum plow weight. Rear compensating weight may be required to maintain front axle weight below 65% of total vehicle weight when equipped with snow plow. Consult your snow plow manufacturer for specific compensating weight recommendation.

TRIM LEVELS

CONFIGURATIONS	SIERRA	SLE	SLT	DENALI
REGULAR CAB	○	○	—	—
DOUBLE CAB	○	○	○	—
CREW CAB	○	○	○	○
4X2	○	○	○	—
4X4	○	○	○	○
MECHANICAL				
AIR CLEANER High capacity. Included and only available with Z71 Off-Road Suspension Package on SLE and SLT.	—	○	○	●
ALTERNATOR 150 amps	●	●	●	●
ALUMINIZED STAINLESS-STEEL MUFFLER AND TAILPIPE	●	●	●	●
BATTERY Heavy-duty maintenance-free with rundown protection and retained accessory power	●	●	●	●
BRAKES 4-wheel disc, 4-wheel anti-lock with Duralife rotors	●	●	●	●
AUXILIARY EXTERNAL TRANSMISSION OIL COOLER On Sierra and SLE trims, included and only available with 5.3L V8 engine	○	○	○	●
EXTERNAL ENGINE OIL COOLER	●	●	●	●
EATON® HEAVY-DUTY AUTOMATIC LOCKING REAR DIFFERENTIAL Standard on 4x4 SLE models and included on 4x2 models with Z71 Off-Road Suspension Package, Trailing Package or Max Trailing Package	○	●	●	●
ENGINE 4.3L V6 EcoTec3 with aluminum block. Includes Active Fuel Management, Direct Injection and continuously Variable Valve Timing.	●	●	—	—
5.3L V8 EcoTec3 with aluminum block. Includes Active Fuel Management, Direct Injection and continuously Variable Valve Timing.	○	○	●	●
6.2L V8 EcoTec3 with aluminum block. Includes Active Fuel Management, Direct Injection and continuously Variable Valve Timing.	—	—	○	○
STABILITRAK STABILITY CONTROL SYSTEM Includes Proactive Roll Avoidance, traction control, electronic trailer sway control and Hill Start Assist	●	●	●	●
MAGNETIC RIDE CONTROL SUSPENSION SYSTEM	—	—	—	●
Z71 OFF-ROAD SUSPENSION PACKAGE Includes monotube Rancho® shocks, Z71 chrome side emblems, high-capacity air cleaner, Hill Descent Control, underbody transfer case shield on 4x4 models and recovery hooks on 4x2 models. Included with available All-Terrain Package. On SLE, includes automatic locking rear differential on 4x2 models. Also includes [UHN] 18" bright machined-aluminum wheels. This package is available with optional 20" wheels.	—	○	○	—
TRAILERING PACKAGE Includes automatic locking rear differential on Sierra and 4x2 SLE models, trailer hitch platform and integrated 7-pin and 4-pin connectors. On SLE Double and Crew Cab models, included when available All-Terrain Package, Max Trailing Package or SLE Premium Package is ordered.	○	○	●	●
MAX TRAILERING PACKAGE Includes 248 mm [9.76"] rear axle, 3.73 axle ratio with 6-speed automatic, 3.42 axle ratio with 8-speed automatic, trailer brake controller, enhanced cooling radiator, revised shock tuning for increased control, heavier-duty rear springs and increased RGAWR to 1950 kg [4300 lb.]. On SLE, includes Trailing Package and locking rear differential on 4x2 models. Also requires [UHN] 18" or [RD3] 20" aluminum wheels and 5.3L V8 engine. Not available with Z71 Off-Road Suspension Package. On SLT, requires [RCW] 18" or [NZM] 20" aluminum wheels when ordered with 5.3L V8 engine. Also requires [NZM] 20" or [RD3] 20" aluminum wheels when ordered with 6.2L V8 engine. Not available with Z71 Off-Road Suspension Package.	—	○	○	—
TIRE PRESSURE MONITORING SYSTEM Does not monitor spare tire	●	●	●	●
TRANSMISSION 6-speed automatic, electronically controlled with overdrive and Tow/Haul mode. Includes Cruise Grade Braking and Powertrain Grade Braking.	●	●	●	●
8-speed automatic, electronically controlled with overdrive and Tow/Haul mode. Includes Cruise Grade Braking and Powertrain Grade Braking. Included and only available with 6.2L V8 engine.	—	—	○	○
INTEGRATED TRAILER BRAKE CONTROLLER Requires Trailing Package on Sierra and SLE trims. Included with Max Trailing Package.	○	○	○	○
TRANSFER CASE 2-speed. Includes floor-mounted shifter (4x4 models only).	●	—	—	—
AutoTrac active transfer case (4x4 models only)	—	●	●	●
UNDERBODY TRANSFER CASE SHIELD 4x4 only. Included and only available with Z71 Off-Road Suspension Package on SLE and SLT.	—	○	○	●
HILL DESCENT CONTROL Included and only available with Z71 Off-Road Suspension Package on SLE and SLT	—	○	○	●
SNOW PLOW PREP PACKAGE Includes heavy-duty front springs, underbody transfer case shield, 170-amp alternator, provisions for roof-mounted lamps and high-capacity air cleaner. Available on 4x4 Regular Cab models only.	○	○	—	—
INSTRUMENTATION AND CONTROLS				
DRIVER INFORMATION CENTRE With 90 mm [3.5"] diagonal monochromatic display. Provides warning messages, odometer, trip odometer and basic vehicle information.	●	—	—	—
With 107 mm [4.2"] diagonal colour display. Includes driver personalization, warning messages, odometer, trip odometer and vehicle information.	—	●	●	—
203 mm [8"] diagonal colour customizable display	—	—	—	●
DEFOGGER Rear-window electric. On SLE, included and only available with SLE Preferred Package, SLE Convenience Package or SLE Premium Package.	○	○	●	●
POWER-ADJUSTABLE PEDALS On SLE, included and only available with SLE Convenience Package. Not available on Regular Cab.	—	○	●	●

KEY ● STANDARD ○ AVAILABLE — NOT AVAILABLE

TRIM LEVELS

TRIM LEVELS	SIERRA	SLE	SLT	DENALI
110-VOLT POWER OUTLET In-cabin, 3-prong, household-style outlet. Included and only available with Convenience Package on Sierra trim. On SLE, included and only available with the SLE Preferred Package or SLE Premium Package.	○	○	●	●
REAR PARK ASSIST Ultrasonic. On SLE, included and only available with All-Terrain Package or SLE Convenience Package. On SLT, included and only available with All-Terrain Package.	—	○	○	—
FRONT AND REAR PARK ASSIST Ultrasonic. Included and only available with SLT Preferred Package, Driver Alert Package or All-Terrain SLT Crew Cab "Plus" Package. On SLE, requires Regular Cab model. Included and only available with Driver Alert Package.	—	○	○	●
STEERING WHEEL Leather-wrapped with audio and cruise controls	—	●	●	—
Heated and leather-wrapped with audio and cruise controls. On SLT, included and only available with SLT Preferred Package or All-Terrain SLT Crew Cab "Plus" Package.	—	—	○	●
STEERING COLUMN Tilt-Wheel, manual operation	●	●	—	—
Tilt-Wheel and manual telescopic operation. On SLE, included and only available with SLE Preferred Package or SLE Premium Package. Not available with 4.3L V6 engine.	—	○	●	●
SEATING				
SEATS Front 3-passenger cloth 40/20/40 split bench with driver and front-passenger manual recline, manual driver lumbar control and outboard head restraints. Includes centre fold-down armrest with storage.	●	—	—	—
Front 3-passenger vinyl 40/20/40 split bench with driver and front-passenger manual recline and outboard head restraints. Includes centre fold-down armrest with storage.	○	—	—	—
Front 3-passenger cloth 40/20/40 split bench with driver and front-passenger manual recline and outboard head restraints. Includes centre fold-down armrest and lockable storage compartment in lower seat cushion. Not available with All-Terrain Package.	—	●	—	—
Front 3-passenger leather-appointed 40/20/40 split bench with heated seat cushions and seatbacks. Not available on Regular Cab models or with All-Terrain Package. Requires Jet Black interior trim, SLE Preferred Package or SLE Premium Package.	—	○	—	—
Front 3-passenger leather-appointed 40/20/40 split bench with 10-way power seat adjusters. Includes power lumbar control, heated seat cushions and seatbacks, 2-position driver memory (does not apply to lumbar adjuster) and adjustable head restraints.	—	—	●	—
Front cloth bucket seats with 10-way driver-seat power adjuster, 6-way passenger-seat power adjuster, heated seat cushions and seatbacks, adjustable head restraints, floor console and storage pockets	—	○	—	—
Front leather-appointed bucket seats with 10-way power seat adjusters including power lumbar control, heated seat cushions and seatbacks, 2-position driver memory (does not apply to lumbar adjuster), adjustable head restraints and floor console and storage pockets. Included with available All-Terrain Package.	—	—	○	—
Seat adjuster, driver 10-way power. Requires bench seat. Included and only available with SLE Preferred Package and SLE Premium Package.	—	○	—	—
Heated driver and front-passenger cloth seating. Requires SLE Preferred Package or SLE Premium Package and cloth 40/20/40 split bench seat.	—	○	—	—
Heated and cooled perforated leather-appointed front bucket seats. Included with Driver Alert Package. Not available with All-Terrain Package. On Denali, includes embossed Denali on front seats and 12-way driver and front-passenger power adjuster, including power lumbar control.	—	—	○	●
Folding rear 3-passenger bench. Double Cab models only. Includes child seat top tether anchor.	●	—	—	—
Folding rear 60/40 split 3-passenger bench. Includes child seat top tether anchor. Double and Crew Cab models only.	●	●	●	●
INTERIOR DETAILS				
CLIMATE CONTROL Single-zone manual air conditioning	●	●	—	—
Dual-zone automatic climate control. On SLE, included and only available with SLE Preferred Package or SLE Premium Package. Not available on Regular Cab models.	—	○	●	●
CRUISE CONTROL Steering-wheel-mounted	●	●	●	●
DOOR LOCKS Power	●	●	●	●
FLOOR COVERING Graphite-coloured rubberized vinyl	●	—	—	—
Colour-keyed carpeting with rubberized vinyl floor mats. (Double and Crew Cab models include second-row floor mats.)	○	○	●	—
Colour-keyed carpeted first- and second-row floor mats. Included and only available with All-Terrain Package on SLE and SLT.	—	○	○	●
NOISE CONTROL SYSTEM Active noise cancellation. Included and only available with 6.2L V8 engine.	—	—	○	○
REMOTE VEHICLE STARTER SYSTEM On SLE, included and only available with SLE Preferred Package or SLE Premium Package	—	○	●	●
REMOTE KEYLESS ENTRY Included and only available with Convenience Package on Sierra trim	○	●	●	●
REARVIEW MIRROR With manual day/night adjustment	●	●	—	—
With inside rearview auto-dimming feature. On SLE, included and only available with All-Terrain Package or black heated power camper mirrors.	—	○	●	●
SILL PLATES Bright. On SLE and SLT, included and only available with All-Terrain Package. Front only on Double Cab models.	—	○	○	●
SUNROOF Power sliding with express-open. Crew Cab models only.	—	—	○	○
UNIVERSAL HOME REMOTE On SLE, included and only available with SLE Preferred Package or SLE Premium Package. Not available on Regular Cab models.	—	○	●	●
WINDOWS Power with driver express-up and -down and express-down on all other windows. Standard on all Double and Crew Cab models.	○	●	●	●
Power rear sliding with rear defogger. On SLE, included and only available with SLE Convenience Package. On SLT, requires SLT Preferred Package or All-Terrain SLT Crew Cab "Plus" Package. Not available on Regular Cab models.	—	○	○	●

TRIM LEVELS

	SIERRA	SLE	SLT	DENALI
OPTION PACKAGES				
ALL-TERRAIN PACKAGE Includes 18" aluminum wheels, fog lamps, unique grille with body-colour surround and chrome accents, Z71 Off-Road Suspension Package with monotube Rancho® shocks, Trailing Package, All-Terrain chrome door badge, underbody shield, rear park assist, body-colour front and rear bumpers, cloth heated bucket seats (includes 10-way power driver and 6-way passenger seats), carpeted floor mats, bright sill plates and projector-beam headlamps with LED signature lighting. SLE models include chrome door handles and mirror caps, chrome full-feature mirrors, chrome bodyside mouldings, front fog lamps, trailing equipment and halogen projector-beam headlamps with LED signature. SLT models include leather-appointed front bucket seats and Bose® premium audio system. Not available with Driver Alert Package. Requires 4x4 Double or Crew Cab model.	—	○	○	—
ALL-TERRAIN SLT CREW CAB "PLUS" PACKAGE Includes (NZH) 20" ultra-bright machined-aluminum wheels with painted accents, front and rear park assist, heated steering wheel, 152 mm (6") rectangular chrome tubular assist steps and rear sliding power window. Requires All-Terrain Package. Not available with SLT Preferred Package.	—	—	○	—
ALL-TERRAIN CHROME BUMPERS PACKAGE Includes front chrome bumper, rear chrome bumper and rear bumper corner steps. Requires available All-Terrain Package.	—	○	○	—
SIERRA APPEARANCE PACKAGE Includes (RD7) 17" stainless-steel-clad wheels and deep-tinted glass	○	—	—	—
SIERRA CONVENIENCE PACKAGE Includes outside heated power-adjustable mirrors, remote keyless entry, 110-volt outlet, LED cargo box lighting and Rear Vision Camera. Includes power windows on Regular Cab models.	○	—	—	—
DRIVER ALERT PACKAGE Includes Lane Departure Warning, Forward Collision Alert, front and rear park assist and Safety Alert Driver Seat. Requires heated and cooled driver and passenger front bucket seats on SLT. Not available with All-Terrain Package. On SLE, requires Regular Cab model.	—	○	○	○
SLE CONVENIENCE PACKAGE Includes power-adjustable pedals, rear park assist, rear power-sliding window with rear defogger and heated, power-adjustable, power-folding and driver-side auto-dimming mirrors with integrated turn-signal indicators, chrome caps and puddle lamps. Not available on Regular Cab models.	—	○	—	—
SLE PREFERRED PACKAGE Includes driver 10-way power seat adjuster with front 40/20/40 split bench seats only, remote vehicle starter system, front fog lamps, rear defogger, manual tilt-telescopic steering column on V8 models and 110-volt power outlet. Also includes Universal Home Remote and dual-zone automatic climate control on Double and Crew Cab models.	—	○	—	—
SLT PREFERRED PACKAGE Includes front and rear park assist, heated steering wheel and sliding rear window. Not available with All-Terrain SLT Crew Cab "Plus" Package.	—	—	○	—
SLE PREMIUM PACKAGE Includes driver 10-way power seat adjuster with front 40/20/40 split bench only, remote vehicle starter system, front fog lamps, Universal Home Remote, rear-window defogger, manual tilt-telescopic steering column, 110-volt power outlet, dual-zone climate control and Trailing Package. Includes rear locking differential on 4x2 models. Not available with SLE Preferred Package or Regular Cab models.	—	○	—	—
SLT CREW CAB VALUE PACKAGE Includes 152 mm (6") chrome tubular assist steps, Bose premium audio system and (NZM) 20" chrome aluminum wheels. Not available with All-Terrain Package. When 6.2L V8 is ordered, front bucket seats are required.	—	—	○	—
ENTERTAINMENT / COMMUNICATION / NAVIGATION				
107 mm (4.2") DIAGONAL COLOUR RADIO Includes AM/FM, USB port, ¹ auxiliary jack and SD card slot	●	—	—	—
107 mm (4.2") DIAGONAL COLOUR RADIO WITH INTELLILINK² Includes AM/FM/CD, USB ports, ¹ SD card slot, auxiliary jack, Bluetooth [®] streaming audio for music and select phones, hands-free smartphone integration and voice-activated technology for radio and phone. On SLE Regular Cab models, includes SiriusXM ³ (standard for 3 months).	○	—	—	—
203 mm (8") DIAGONAL COLOUR TOUCH RADIO WITH INTELLILINK² Includes AM/FM/SiriusXM ³ (standard for 3 months), USB ports, ¹ SD card slot, auxiliary jack, Bluetooth [®] streaming audio for music and select phones, hands-free smartphone integration and voice-activated technology for radio and phone	—	●	●	—
203 mm (8") DIAGONAL COLOUR TOUCH RADIO WITH NAVIGATION⁴ Includes all features of 203 mm (8") diagonal Colour Touch Radio plus Navigation feature. Not available with All-Terrain Package on SLE.	—	○	○	●
Single-slot CD/MP3 player. Included and only available with IntelliLink ² audio systems.	○	●	●	●
6-SPEAKER AUDIO SYSTEM 4-speaker on Regular Cab models	●	●	●	—
Bose premium audio system with 6 speakers (7-speaker system including subwoofer when ordered with bucket seats). Included with SLT All-Terrain Package and SLT Crew Cab Value Package.	—	○	○	●
ACTIVE NOISE CANCELLATION Included and only available with 6.2L V8 engine	—	—	○	○
REAR-SEAT DVD ENTERTAINMENT SYSTEM Includes rear-seat DVD/Blu-ray player with 234 mm (9.2") diagonal LCD screen, 2 sets of wireless headphones and A/V remote control. Requires front bucket seats and Bose premium audio system. Replaces single-slot CD/MP3 player. Crew Cab models only.	—	—	○	○
BLUETOOTH[®] FOR PHONE Personal cellphone connectivity to vehicle audio system. Included and only available with IntelliLink ² on Sierra trim.	○	●	●	●
ONSTAR 5-year OnStar Basic Plan ⁵ and 6-month subscription to Directions & Connections Plan. On Sierra trim, included and only available with 107 mm (4.2") diagonal Colour Touch Radio with IntelliLink. ²	○	●	●	●
OnStar with 4G LTE ⁶ Includes built-in Wi-Fi [®] hotspot capability (with 3-month/3GB trial, whichever comes first). On Sierra trim, included and only available with 107 mm (4.2") diagonal Colour Touch Radio with IntelliLink. ²	○	●	●	●
SIRIUSXM³ SATELLITE RADIO Including 3 trial months of service. On Sierra trim, requires 107 mm (4.2") diagonal Colour Touch Radio with IntelliLink. ²	○	●	●	●
EXTERIOR STYLING AND FUNCTIONALITY				
ASSIST STEPS Chromed tubular with 152 mm (6") rectangular design. Factory-installed on Crew Cab models only. Included with SLT Crew Cab Value Package.	○	○	○	●
BEDLINER Spray-in with GMC logo. Includes Denali logo when ordered on Denali models.	○	○	○	●
BUMPERS Front, chrome	●	●	●	—
Rear, chrome with integrated rear bumper corner steps	●	●	●	—
Front, body-colour. Included and only available with All-Terrain Package on SLE and SLT.	—	○	○	●
Rear, body-colour with integrated rear bumper corner steps. Included and only available with All-Terrain Package on SLE and SLT.	—	○	○	●
KEY ● STANDARD ○ AVAILABLE — NOT AVAILABLE				

TRIM LEVELS

	SIERRA	SLE	SLT	DENALI
CARGO BOX Movable tie-downs, high-mounted (4)				
Box rail caps	●	●	●	●
DOOR HANDLES Black	●	—	—	—
Body-colour. Not available with SLE All-Terrain Package.	—	—	—	—
Chrome. On SLE, included and only available with All-Terrain Package.	—	○	●	●
FOG LAMPS Front, halogen. On SLE, included and only available with SLE Preferred Package, SLE Premium Package or All-Terrain Package.	—	○	●	●
GRILLE SURROUND Chrome. Grille is body-colour when All-Terrain Package is ordered on SLE and SLT.	●	●	●	●
Chrome-accented centre	—	●	●	—
Chrome with unique Denali accents	—	—	—	●
GLASS Solar-absorbing tinted	○	—	—	—
Deep-tinted. Included and only available with Appearance Package on Sierra trim.	●	●	●	●
LIGHTS Halogen projector-beam headlamps	●	●	—	—
Halogen projector-beam with LED signature. On SLE, included and only available with All-Terrain Package.	—	○	●	●
Under-rail LED lighting, cargo box. Included and only available with Convenience Package on Sierra trim.	○	●	●	●
MOULDINGS Body colour. Includes chrome bodyside mouldings when available All-Terrain Package is ordered.	—	—	—	—
Bodyside, chrome. On SLE, included and only available with All-Terrain Package.	—	○	●	●
RECOVERY HOOKS Front frame-mounted (Black). Standard on Denali and all 4x4 models. Included and only available with Z71 Off-Road Suspension Package on 4x2 SLE and SLT models.	●	●	●	●
LOCKABLE TAILGATE Includes EZ-Lift and Lower feature on SLE, SLT and Denali	●	●	●	●
WHEELHOUSE LINERS Rear. Double Cab and Crew Cab models only.	—	●	●	●
OUTSIDE MIRRORS				
MIRRORS Black, manual	●	—	—	—
Black, power-adjustable with heated glass and driver-side spotter mirror. Included and only available with Convenience Package on Sierra trim. Mirror caps are body-colour on SLE.	○	●	—	—
Chrome cap, heated, power-adjustable, power-folding and driver-side auto-dimming with integrated turn-signal indicators and puddle lamps (includes driver-side spotter mirror). On SLE, included and only available with All-Terrain Package and SLE Convenience Package.	—	○	●	●
Black, vertical trailinger-style with manual folding and extension and lower convex spotter glass. Requires Trailing Package.	○	—	—	—
Black, heated, power-adjustable vertical trailinger-style with manual folding and extension, lower convex spotter glass, integrated turn-signal indicators, rear guidance lamps and amber auxiliary clearance lamps. SLE trim includes auto-dimming inside rearview mirror. Requires available Max Trailing Package.	—	○	—	—
Chrome cap, heated, power-adjustable, vertical trailinger-style with power folding, manual extension, driver memory, lower convex spotter glass, integrated turn-signal indicators, rear guidance lamps and amber auxiliary clearance lamps. Requires available Max Trailing Package.	—	—	○	—
SAFETY AND SECURITY				
AIR BAGS⁷ Dual-stage frontal for driver and front passenger with Passenger Sensing System	●	●	●	●
Front-seat-mounted side-impact driver and right front-passenger air bags for thorax and pelvis protection	●	●	●	●
Front and rear head curtain side-impact air bags for all outboard seating positions	●	●	●	●
DAYTIME RUNNING LAMPS With automatic lamp control	●	●	●	●
LANE DEPARTURE WARNING AND FORWARD COLLISION ALERT Included and only available with Driver Alert Package. On SLE, requires Regular Cab model.	—	○	○	○
REAR VISION CAMERA With dynamic grid lines. On Sierra trim, included and only available with Sierra Convenience Package.	○	●	●	●
SAFETY ALERT DRIVER SEAT Included and only available with Driver Alert Package. On SLE, requires Regular Cab model.	—	○	○	○
THEFT DETERRENT SYSTEM Unauthorized entry. Included and only available with remote vehicle starter system on SLE.	—	○	●	●

¹Not compatible with all devices. ²Full functionality requires compatible Bluetooth and smartphone, and USB connectivity for some devices. Visit intellilink.gmc.gm.ca for more details. ³Available in 10 Canadian provinces and the 48 contiguous United States. Subscription sold separately after trial period. If you decide to continue your service at the end of your trial subscription, the plan you choose will automatically renew and bill at then-current rates until you call 1-877-209-0079 to cancel. Other fees and taxes will apply. All fees and programming subject to change. See SiriusXM "Terms & Conditions" and complete details at siriusxm.ca. ⁴At time of printing, detailed map coverage is available for most major urban areas of the United States and for certain metropolitan areas of Canada (Vancouver, Calgary, Edmonton, Winnipeg, Windsor, London, Toronto, Ottawa, Montreal, Quebec City and Halifax). Coverage is significantly limited outside these areas. ⁵The OnStar Basic Plan is available for 5 years from the date of delivery of the eligible new 2015 model-year vehicle and is transferable. It includes OnStar Vehicle Diagnostics (capabilities vary by model), Dealer Maintenance Notification and access to RemoteLink Key Fob Services (available on select Apple, Android, BlackBerry and Windows devices). Please visit onstar.ca/mobile for more details. The OnStar Basic Plan does not include any Emergency Services, Automatic Crash Response, Stolen Vehicle Assistance, live Advisor service or Hands-Free Calling. These and other services are available under a paid plan. See OnStar User Terms and Privacy Statement (including software terms) for more details. If you sell your vehicle or wish to cancel use of Basic Plan services, you must contact OnStar at 1-888-4-DNSTAR (1-888-466-7827). ⁶Visit onstar.ca for coverage maps, details and system limitations. Services and connectivity may vary by model and conditions. OnStar with 4G LTE connectivity is available on select vehicle models and in select markets. Customers will be able to access OnStar services only if they accept the OnStar User Terms and Privacy Statement (including software terms). OnStar acts as a link to existing emergency service providers. After the trial period (if applicable), an active OnStar service plan is required. ⁷Always use safety belts and the correct restraint for your child's age and size. Even in vehicles equipped with the Passenger Sensing System, children are safer when properly secured in a rear seat in the appropriate infant, child or booster seat. Never place a rear-facing infant restraint in the front seat of any vehicle equipped with an active frontal air bag. See the Owner's Manual and child safety seat instructions for more safety information.

PEACE OF MIND, STANDARD WITH EVERY GMC MODEL

When you build them with quality, you can back them with confidence. That's why General Motors of Canada backs every GMC model with the best coverage in Canada. Program highlights include:

- 2-year/40,000 km Scheduled Lube-Oil-Filter Maintenance Program¹
- 3-year/60,000 km New-Vehicle Limited Warranty²
- 5-year/160,000 km Powertrain Limited Warranty, with \$0 deductible on repairs and the warranty is fully transferable at no charge²
- 5-year/160,000 km Courtesy Transportation²
- 5-year/160,000 km 24/7 Roadside Assistance²
- 6-year/160,000 km rust-through perforation coverage²
- 8-year/130,000 km coverage on catalytic converters and Powertrain Control Modules (PCMs)²

OTHER OWNERSHIP PRIVILEGES AND PROGRAMS:³

- **GM Protection Plan (GMPP)**—The only extended service plan backed by the resources and commitment of General Motors, GMPP may be purchased at the time of sale or subsequently during the New-Vehicle Limited Warranty period.
- **Certified Service**—With GM-certified technicians and GM-approved parts, nobody knows your GM vehicle better.
- **GMC Owner Centre**—As an owner, take advantage of the GMC Owner Centre. This online owner's destination gives you access to coupons, contests, current offers and the latest driving and maintenance tips. Find out more at gmcowner.ca.

TO HELP YOU PURCHASE OR LEASE A NEW VEHICLE:

- **Purchase Financing and Leasing**—On-the-spot financing, see dealer for full details.⁴
- **GM Student Bonus Program**—Students or recent graduates of high school, college or university³ may be eligible to receive a Student Bonus vehicle redemption allowance of \$500 or \$750⁵ (tax inclusive) (purchased vehicle dependant) to use toward the purchase, lease or finance of one eligible new GMC vehicle.
- **The GM Card**—GM cardholders may redeem up to \$2500 GM Card[®] Earnings (subject to Vehicle Redemption Allowances) toward the Total Purchase Price on eligible new GM vehicles.⁵ For full program details, please visit thegmcard.ca.

INFORMATION RESOURCES:

You can find more information about these programs from your GMC dealer, or at these information centres:

- The GM Web site at gm.ca
- The GM Customer Care Centre at 1-800-GM-DRIVE (1-800-463-7483 or 1-800-263-3830 for TDD users)

A WORD ABOUT THIS BROCHURE

Some of the equipment shown or described throughout this brochure may be available at extra cost. We have tried to make this brochure comprehensive and factual. We reserve the right, however, to make changes at any time, without notice, in prices, colours, materials, equipment, specifications, models and availability. Specifications, dimensions, measurements, ratings and other numbers in this brochure and other printed materials provided at the dealership or affixed to vehicles are approximates based upon design and engineering drawings and prototypes and laboratory tests. Your vehicle may differ due to variations in manufacture and equipment. Since some information may have been adapted since the time of printing, please check with your GMC dealer for complete details. General Motors of Canada Limited reserves the right to lengthen or shorten the model year for any product, for any reason, or to start and end model years at different times.

A WORD ABOUT ASSEMBLY

GMC vehicles are equipped with engines and components produced and assembled by different operating units of General Motors, its subsidiaries and suppliers to GM worldwide. We sometimes find it necessary to produce GMC vehicles with different or differently sourced components than originally scheduled. Since some options may be unavailable when your vehicle is assembled, we suggest that you verify that your vehicle includes the equipment you ordered or, if there are changes, that they are acceptable to you.

TRADEMARKS

©2014 General Motors of Canada Limited. All rights reserved. The marks appearing in this brochure, including but not limited to: General Motors, GM, GMC, Sierra, Denali and their respective logos, emblems, slogans and vehicle model names and body designs; and other marks such as Solar-Ray and StabiliTrak are trademarks of General Motors and/or General Motors of Canada Limited, its subsidiaries, affiliates or licensors. OnStar, the OnStar emblem and Directions & Connections are registered trademarks of OnStar, LLC. The SiriusXM name and related logos are trademarks of SiriusXM Canada, Canadian Satellite Radio, Inc. Bluetooth is a registered trademark of Bluetooth SIG, Inc. Apple is a registered trademark of Apple, Inc. Android is a trademark of Google, Inc. BlackBerry is a registered trademark of Research In Motion, Inc. Windows is a registered trademark of Microsoft Corporation. Bose is a registered trademark of the Bose Corporation. Wi-Fi is a registered trademark of Wi-Fi Alliance.

¹The 2-Year Scheduled LDF Maintenance Program provides eligible customers in Canada who have purchased, leased or financed a new eligible 2015 MY GMC vehicle with an ACDelco oil and filter change, in accordance with the Oil Life Monitoring System and the Owner's Manual, for 2 years or 40,000 km, whichever occurs first, with a limit of four lube-oil-filter services in total, performed at participating GM dealers. Fluid top-offs, inspections, tire rotations, wheel alignments and balancing, etc., are not covered. This offer may not be redeemed for cash and may not be combined with certain other consumer incentives available on GM vehicles. General Motors of Canada Limited reserves the right to amend or terminate this offer, in whole or in part, at any time without prior notice. Additional conditions and limitations apply. See dealer for details. ²Whichever comes first. Conditions and limitations apply, see dealer for details. ³Conditions and limitations apply. ⁴Subject to eligibility. ⁵Program subject to change.



191-16-B-013E