

Foreword

Your INFINITI represents a new way of thinking about vehicle design. It integrates advanced engineering and superior craftsmanship with a simple, refined aesthetic sensitivity associated with traditional Japanese culture.

The result is a different notion of luxury and beauty. The car itself is important, but so is the sense of harmony that the vehicle evokes in its driver, and the sense of satisfaction you feel with the INFINITI — from the way it looks and drives to the high level of dealer service.

To ensure that you enjoy your INFINITI to the fullest, we encourage you to read this Owner's Manual immediately. It explains all of the features, controls and performance characteristics of your INFINITI; it also provides important instructions and safety information.

A separate Warranty Information Booklet can be found in your Owner's literature portfolio. Always carry it with you when you take your INFINITI to an authorized dealer. The portfolio contents provide complete information about all warranties covering this vehicle, the periodic maintenance required to keep the warranties in effect as well as the INFINITI Roadside Assistance program.

Additionally, a separate Customer Care and Lemon Law Information Booklet will

explain how to resolve any concerns you may have with your vehicle, as well as clarify your rights under your state's lemon law.

INFINITI is dedicated to providing a satisfying ownership experience for as long as you own your car. Should you have any questions regarding your INFINITI or your INFINITI dealer, please contact our Consumer Affairs department at:

In the U.S. 1-800-662-6200
In Canada 1-800-361-4792

READ FIRST — THEN DRIVE SAFELY

Before driving your vehicle please read your Owner's Manual carefully. This will ensure familiarity with controls and maintenance requirements, assisting you in the safe operation of your vehicle.



WARNING

IMPORTANT SAFETY INFORMATION REMINDERS FOR SAFETY!

Follow these important driving rules to help ensure a safe and comfortable trip for you and your passengers!

- **NEVER** drive under the influence of alcohol or drugs.
- **ALWAYS** observe posted speed limits and never drive too fast for conditions.
- **ALWAYS** use your seat belts and appropriate child restraint systems. Pre-teen children should be seated in the rear seat.
- **ALWAYS** provide information about the proper use of vehicle safety features to all occupants of the vehicle.
- **ALWAYS** review this Owner's Manual for important safety information.

MODIFICATION OF YOUR VEHICLE

This vehicle should not be modified. Modification could affect its performance, safety or durability, and may even violate governmental regulations. In addition, damage or performance problems resulting from modifications may not be covered under INFINITI warranties.

WHEN READING THE MANUAL

This manual includes information for all options available on this model. Therefore,

you may find some information that does not apply to your vehicle.

All information, specifications and illustrations in this manual are those in effect at the time of printing. INFINITI reserves the right to change specifications or design at any time without notice.

IMPORTANT INFORMATION ABOUT THIS MANUAL

You will see various symbols in this manual. They are used in the following ways:



WARNING

This is used to indicate the presence of a hazard that could cause death or serious personal injury. To avoid or reduce the risk, the procedures must be followed precisely.



CAUTION

This is used to indicate the presence of a hazard that could cause minor or moderate personal injury or damage to your vehicle. To avoid or reduce the risk, the procedures must be followed carefully.

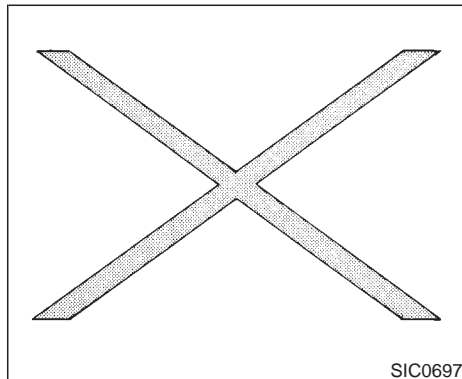

SIC0697

If you see this symbol, it means **Do not do this** or **Do not let this happen**.



If you see a symbol similar to these in an illustration, it means the arrow points to the front of the vehicle.



Arrows in an illustration that are similar to these indicate movement or action.

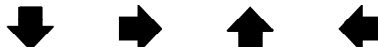

Arrows in an illustration that are similar to these call attention to an item in the illustration.

CALIFORNIA PROPOSITION 65 WARNING



WARNING

Engine Exhaust, some of its constituents, and certain vehicle components contain or emit chemicals known to the State of California to cause cancer and birth defects or other reproductive harm. In addition, certain fluids contained in vehicles and certain products of component wear contain or emit chemicals known to the State of California to cause cancer and birth defects or other reproductive harm.



INFINITI®

© 2004 NISSAN MOTOR CO., LTD.
TOKYO, JAPAN

All rights reserved. No part of this Owner's Manual may be reproduced or stored in a retrieval system, or transmitted in any form, or by any means, electronic, mechanical, photocopying, recording or otherwise, without the prior written permission of Nissan Motor Co., Ltd.

Table of Contents

Illustrated table of contents	0
Safety — Seats, seat belts and supplemental restraint systems	1
Instruments and controls	2
Pre-driving checks and adjustments	3
Display screen, heater, air conditioner and audio systems	4
Starting and driving	5
In case of emergency	6
Appearance and care	7
Maintenance and do-it-yourself	8
Technical and consumer information	9
Index	10

0 Illustrated table of contents

Exterior	0-2
Instrument panel	0-3
Meters and gauges	0-4
Engine compartment locations.....	0-5

EXTERIOR

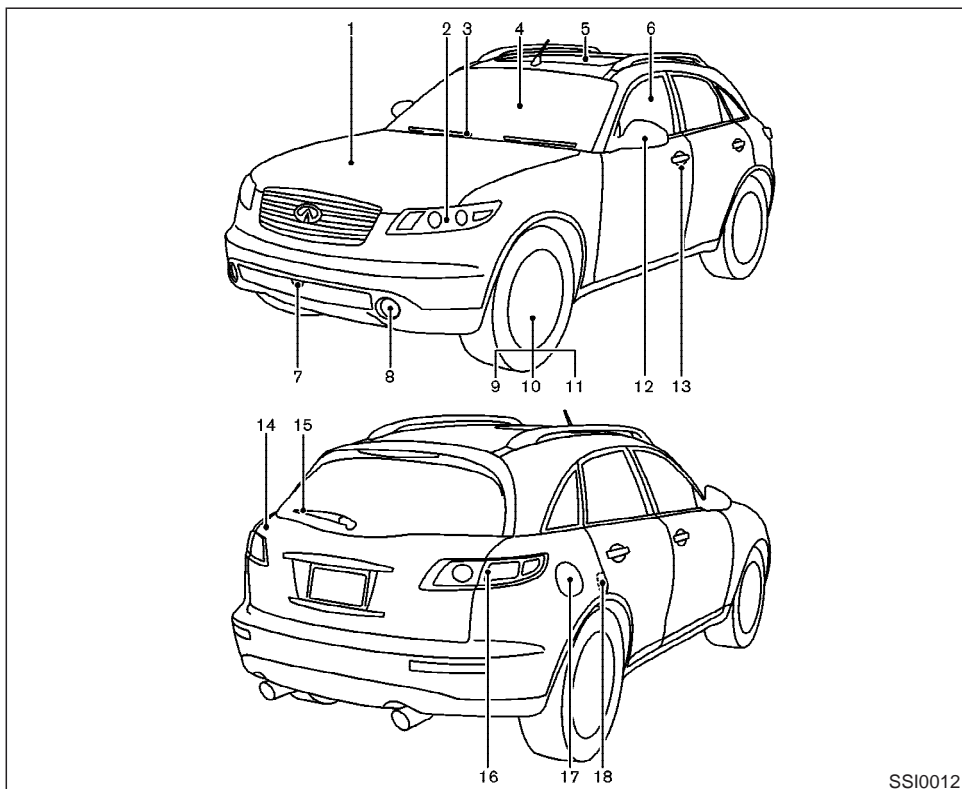

1. Engine hood (Page 3-25)
2. Front lights (P.2-21)
3. Windshield wiper and washer switch (P.2-19)
4. Windshield (P.8-20)
5. Sunroof (P.2-36)
6. Power windows (P.2-35)
7. Towing hook (P.6-14)
8. Fog light and switch (P.2-25)
9. Tire pressure (P.8-32)
10. Flat tire (P.6-2)
11. Tire chains (P.8-37)
12. Mirrors (P.3-31)
13. Door and locks (P.3-3)
14. Trunk lid (P.3-25)
15. Rear wiper (P.8-22)
16. Rear combination light (P.8-28)
17. Fuel filler lid (P.3-27)
18. Child safety locks (P.3-5)

SSI0012

INSTRUMENT PANEL

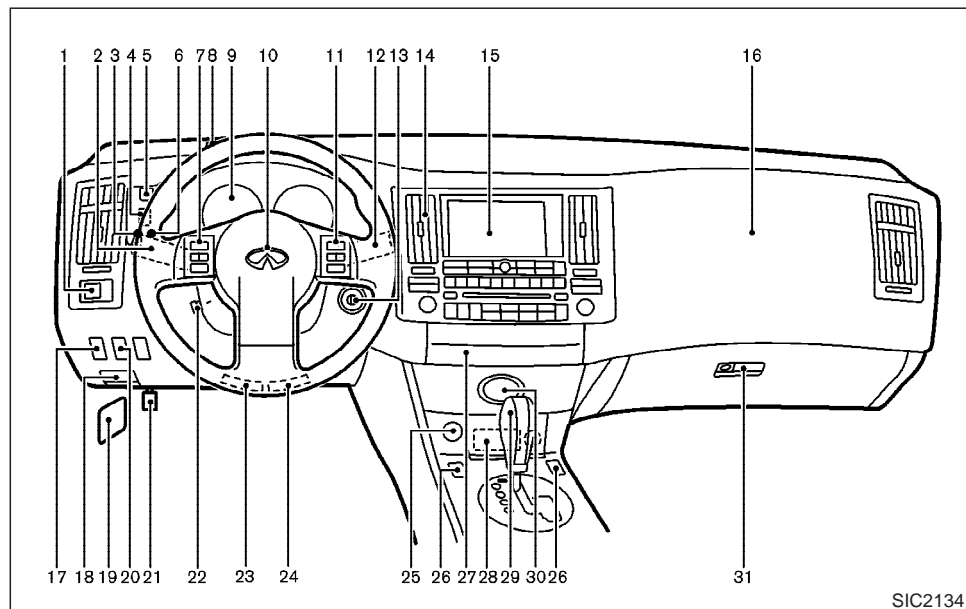

1. Outside mirror remote control (P.3-32)
2. Headlight, fog light and turn signal switch (P.2-20)
3. Trip odometer reset knob (P.2-4)
4. Instrument brightness control switch (P.2-24)

5. Headlight aiming control switch (P.2-23)
6. Trip odometer select knob (P.2-4)
7. Steering switch for Audio (P.4-33)
8. Security indicator light (P.2-18)
9. Meters and gauges (P.2-3)
10. Driver supplemental air bag (P.1-19)

11. Cruise control main/set switch (P.5-16) or Intelligent cruise control switch (if so equipped) (P.5-18)
12. Windshield wiper/washer switch (P.2-19)
13. Ignition switch (P.5-8)/Ignition knob (P.3-13)
14. Center ventilator (P.4-16)
15. Display, Climate and Audio control switches/buttons (P.4-2)/Navigation system*
16. Front passenger supplemental air bag (P.1-19)
17. Snow mode switch (P.2-27)
18. Hood release handle (P.3-25)
19. Fuse box (P.8-23)
20. VDC OFF switch (P.2-28)
21. Parking brake pedal/parking brake release pedal (P.5-15)
22. Tilting/telescopic steering wheel switch (if so equipped) (P.3-29)
23. Tilting steering wheel lock lever (if so equipped) (P.3-29)
24. Telescopic steering wheel lock lever (P.3-29)
25. Hazard warning flasher switch (P.2-25)
26. Heated seat switch (if so equipped) (P.2-26)
27. Cassette player (P.4-26)
28. Cigarette lighter and ashtray (P.2-30)

SIC2134

METERS AND GAUGES

29. Automatic transmission selector lever (P.5-12)

30. Clock (P.2-28)

31. Glove box (P.2-32)

*: Refer to the separate Navigation System Owner's Manual. (if so equipped)

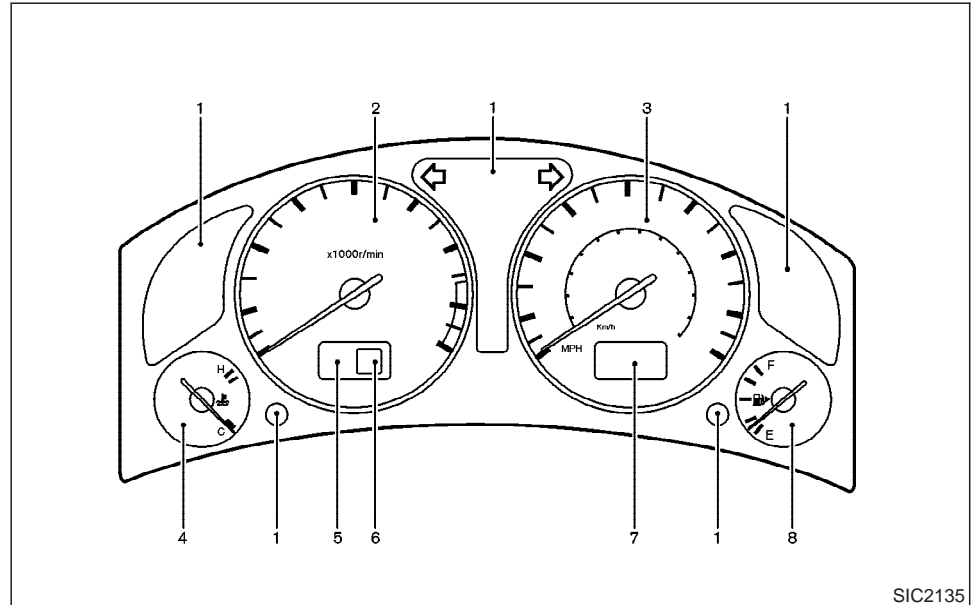

SIC2135

1. Warning/Indicator lights (P.2-9)

2. Tachometer (P.2-4)

3. Speedometer (P.2-4)

4. Engine coolant temperature gauge (P.2-5)

5. Intelligent cruise control system display (if

so equipped) (P.5-18)

6. Automatic transmission position indicator (P.5-12)

7. Odometer (Total/Twin trip) (P.2-4)

8. Fuel gauge (P.2-5)

ENGINE COMPARTMENT CHECK LOCATIONS

VQ35DE engine

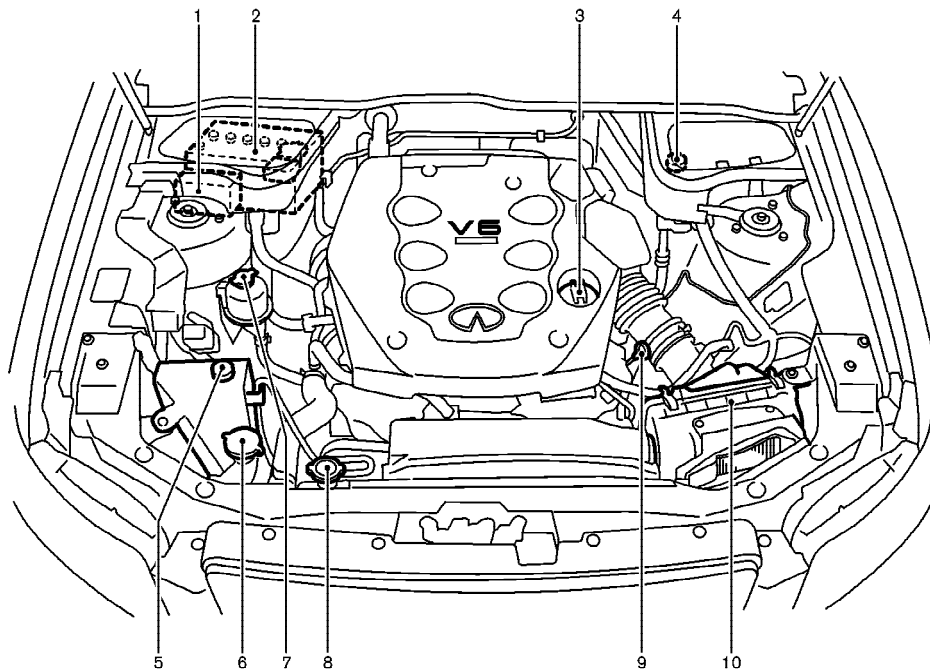

SDI1524

1. Fuse/fusible link holder (P.8-23)
2. Battery (P.8-17)
3. Engine oil filler cap (P.8-11)
4. Brake fluid reservoir (P.8-15)
5. Engine coolant reservoir (P.8-9)
6. Windshield washer fluid reservoir (P.8-16)
7. Power steering fluid reservoir (P.8-15)
8. Radiator filler cap (P.8-10)
9. Engine oil dipstick (P.8-11)
10. Air cleaner (P.8-20)

VK45DE engine

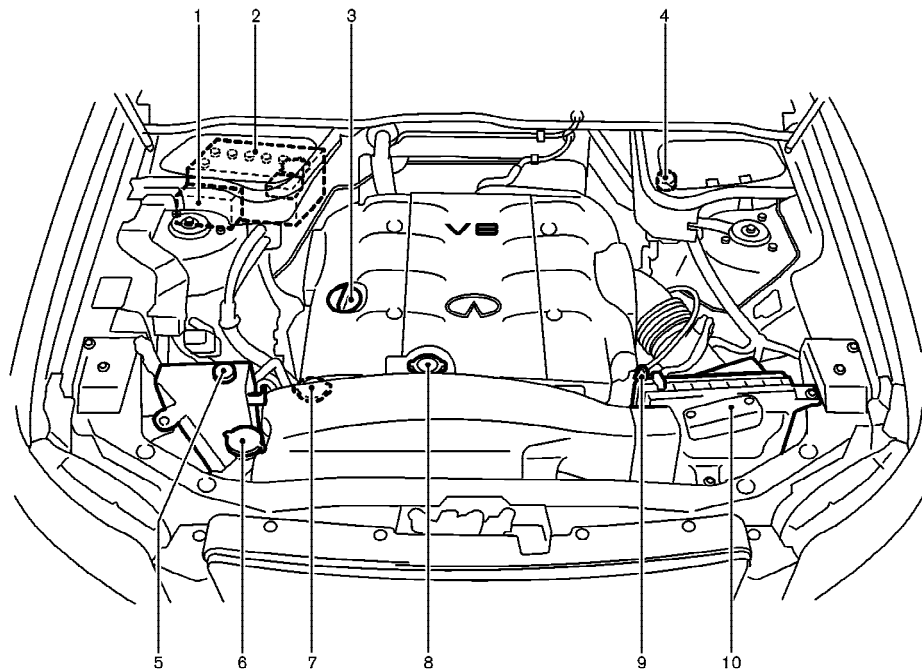

1. Fuse/fusible link holder (P.8-23)
2. Battery (P.8-17)
3. Engine oil filler cap (P.8-11)
4. Brake fluid reservoir (P.8-15)
5. Engine coolant reservoir (P.8-9)
6. Windshield washer fluid reservoir (P.8-16)
7. Power steering fluid reservoir (P.8-15)
8. Radiator filler cap (P.8-10)
9. Engine oil dipstick (P.8-11)
10. Air cleaner (P.8-20)

SDI1531

1 Safety — Seats, seat belts and supplemental restraint systems

Seats	1-2	Injured persons.....	1-25
Front power seat adjustment	1-2	Three-point type seat belt with retractor	1-25
Rear seat adjustment	1-4	Rear center seat belt.....	1-28
Head restraint adjustment	1-6	Seat belt extenders	1-31
Active head restraint (front seats)	1-7	Seat belt maintenance	1-31
Armrest	1-7	Child restraints	1-32
Supplemental restraint system.....	1-8	Precautions on child restraints.....	1-32
Precautions on supplemental restraint system	1-8	Installation on rear seat outboard or center	
Supplemental air bag warning labels	1-19	positions	1-34
Supplemental air bag warning light.....	1-19	LATCH (Lower Anchors and Tethers for Children)	
Seat belts	1-21	system	1-39
Precautions on seat belt usage	1-21	Top tether strap child restraint	1-40
Child safety.....	1-24	Installation on front passenger seat.....	1-41
Pregnant women	1-25		

SEATS

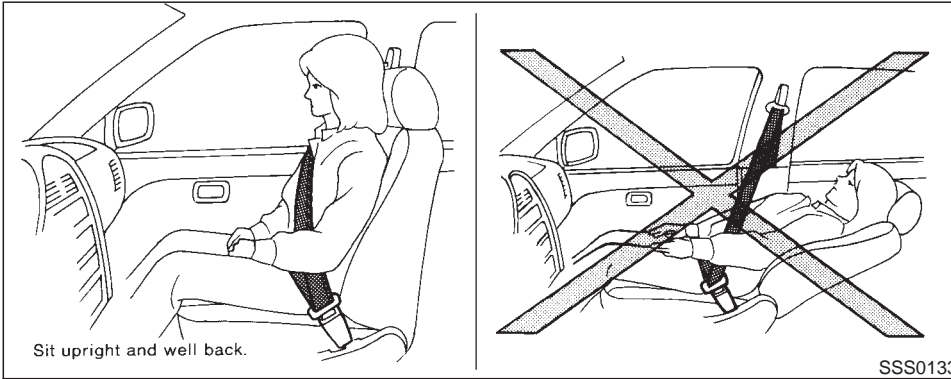

WARNING

- Do not ride in a moving vehicle when the seatback is reclined. This can be dangerous. The shoulder belt will not be against your body. In an accident you could be thrown into it and receive neck or other serious injuries. You could also slide under the lap belt and receive serious internal injuries.

- For most effective protection when the vehicle is in motion, the seat should be upright. Always sit well back in the seat and adjust the seat belt properly. See “Precautions on seat belt usage” later in this section.

FRONT POWER SEAT ADJUSTMENT



WARNING

- Do not adjust the driver’s seat while driving so full attention may be given to vehicle operation.
- Do not leave children unattended inside the vehicle. They could unknowingly activate switches or controls. Unattended children could become involved in serious accidents.

Operating tips

- The seat motor has an auto-reset overload protection circuit. If the motor stops during operation, wait 30 seconds, then reactivate the switch.
- Do not operate the power support seat for a long period of time when the engine is off. This will discharge the battery.

See “Automatic drive positioner” in the “3. Pre-driving checks and adjustments” for automatic drive positioner operation.

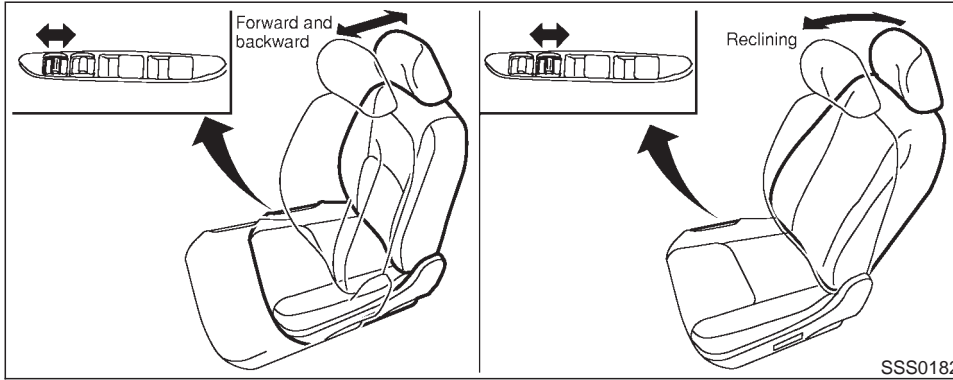

Forward and backward

Moving the switch forward or backward will slide the seat forward or backward to the desired position.

Reclining

Move the recline switch backward until the desired angle is obtained. To bring the seatback forward again, move the switch forward and move your body forward. The seatback will move forward.

The reclining feature allows adjustment of the seatback for occupants of different sizes to help obtain proper seat belt fit. (See "Precautions on seat belt usage" later in this section.) Also, the seatback may be reclined to allow occupants to rest when the vehicle is parked.

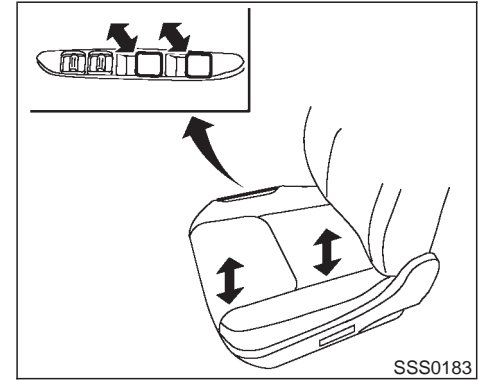

Seat lifter

Pull the switch up or push it down to adjust the angle and height of the seat cushion.

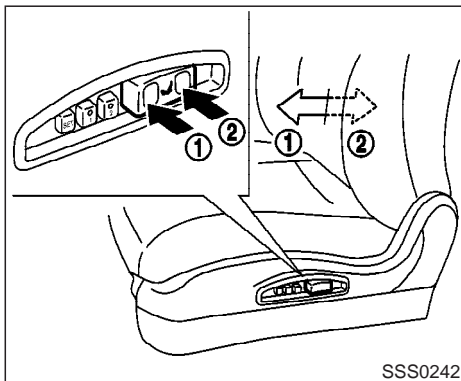

Lumbar support (Driver's seat) — if so equipped

The lumbar support feature provides lower back support to the driver. Push each side of the switch to adjust the seat lumbar area.

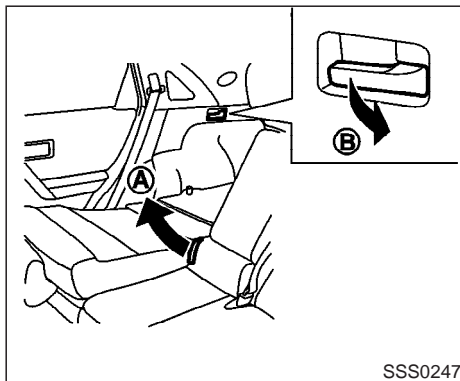

REAR SEAT ADJUSTMENT

Folding

1. Remove the head restraints.
2. Pull the seat belt to side.
3. After removing the cargo cover (if so equipped), pull the lever on the rear seat (A) or pull the lever on both sides of the luggage room (B) and fold the seatback.
4. When resetting the seat, be sure to install the head restraints.



WARNING

- Never allow anyone to ride in the cargo area or on the rear seat when it is in the fold-down position. Use of these areas by passengers without proper restraints could result in serious injury in an accident or sudden stop.
- It is extremely dangerous to ride in a cargo area inside of a vehicle. In a collision, people riding in these areas are more likely to be seriously injured or killed.
- Do not allow people to ride in any area of your vehicle that is not equipped with seats and seat belts. Be sure everyone in your vehicle is in a seat and using a seat belt properly.
- Do not fold down the rear seats when occupants are in the rear seat area, any luggage is on the rear seat or any cup is in the cup holder.
- Head restraints should be adjusted

properly as they may provide significant protection against injury in an accident. Always replace and adjust them properly if they have been removed for any reason.

- If the head restraints are removed for any reason, they should be securely stored to prevent them from causing injury to passengers or damage to the vehicle in case of sudden braking or an accident.
- Properly secure all cargo to help prevent it from sliding or shifting. Do not place cargo higher than the seatbacks. In a sudden stop or collision, unsecured cargo could cause personal injury.
- When returning the seatbacks to the upright position, be certain they are completely secured in the latched position. If they are not completely secured, passengers may be injured in an accident or sudden stop.

- When returning the seatbacks, be sure to attach the rear center seat belt connector.
- Do not unfasten the rear center seat belt connector except when folding down the rear seat.
- When attaching the rear center seat belt connector, be certain that the seatbacks are completely secured in the latched position and the rear center seat belt connector is completely secured.
- If the center seat belt connector and the seatbacks are not secured in the correct position, serious personal injury may result in an accident or sudden stop.

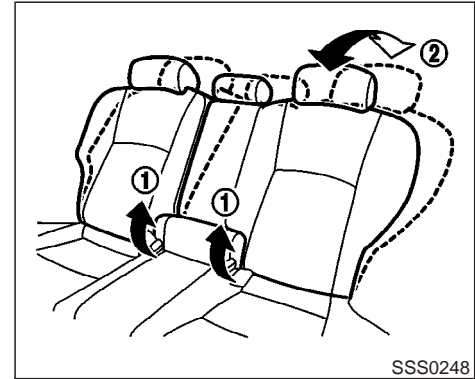

Reclining

Pull the reclining lever ① and position the seat back at the desired angle ②. Release the reclining lever ① after positioning the seat at the desired angle ②.



WARNING

- Do not ride in a moving vehicle when the seatback is reclined. This can be dangerous. The shoulder belt will not be against your body. In an accident

you could be thrown into it and receive neck or other serious injuries. You could also slide under the lap belt and receive serious internal injuries.

- For most effective protection when the vehicle is in motion, the seat should be upright. Always sit well back in the seat and adjust the seat belt properly. See “Seat belts” later in this section for precautions on seat belt usage.
- After adjustment, check to be sure the seat is securely locked.

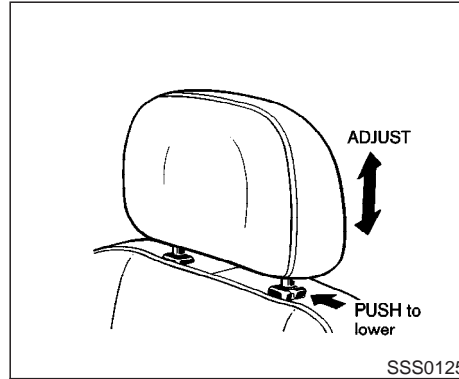

HEAD RESTRAINT ADJUSTMENT

To raise the head restraint, just pull it up. To lower, push the lock knob and push the head restraint down.

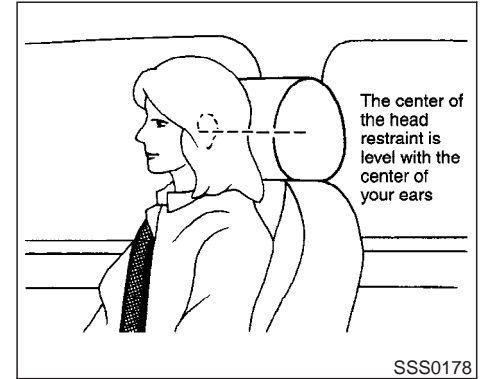

Adjust the head restraints so the center is level with the center of your ears.



WARNING

Head restraints should be adjusted properly as they may provide significant protection against injury in an accident. Do not remove them. Check the adjustment after someone else uses the seat.

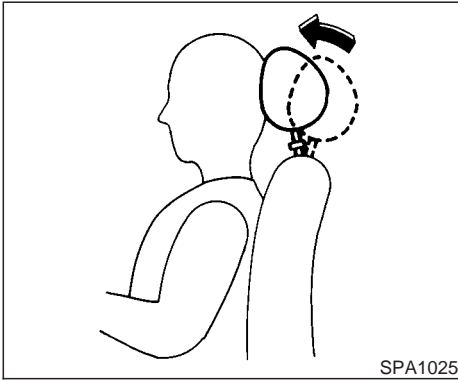

ACTIVE HEAD RESTRAINT (front seats)



WARNING

- Always adjust the head restraints properly as specified in the previous section. Failure to do so can reduce the effectiveness of the active head restraint.

- Active head restraints are designed to supplement other safety systems. Always wear seat belts. No system can prevent all injuries in any accident.
- Do not attach anything to the head restraint stalks. Doing so could impair active head restraint function.

The head restraint moves forward utilizing the force that the seatback receives from the occupant in a rear-end collision. The movement of the head restraint helps support the occupant's head by reducing its backward movement and helping absorb some of the forces that may lead to whiplash type injuries.

Active head restraints are effective for collisions at low to medium speeds in which it is said that whiplash injury occurs most.

Active head restraints operate only in certain rear-end collisions. After the collision, the head restraints return to their original positions.

Properly adjust the active head restraints as described in the previous section.

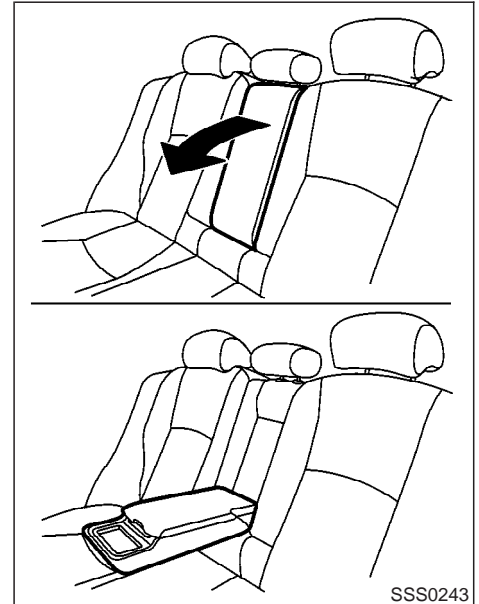

ARMREST

Pull the armrest forward until it is horizontal.

SUPPLEMENTAL RESTRAINT SYSTEM

PRECAUTIONS ON SUPPLEMENTAL RESTRAINT SYSTEM

This Supplemental Restraint System (SRS) section contains important information concerning the driver and passenger front impact supplemental air bags, front seat side-impact supplemental air bags, curtain side-impact air bags and front seat pre-tensioner seat belts.

Supplemental front impact air bag system:

This system can help cushion the impact force to the face and chest of the driver and front passenger in certain frontal collisions.

Supplemental side-impact air bag system:

This system can help cushion the impact force to the chest area of the driver and front passenger in certain side impact collisions. The front seat side-impact supplemental air bags are designed to inflate on the side where the vehicle is impacted.

Supplemental curtain side-impact air bag system:

This system can help cushion the impact force to the head of occupants in front and rear outboard seating positions in certain side impact collisions. The curtain side-impact air bags are designed to inflate on the side where the vehicle is impacted.

These supplemental restraint systems are designed to **supplement** the crash protection

provided by the driver and passenger seat belts and are **not a substitute** for them. Seat belts should always be correctly worn and the occupant seated a suitable distance away from the steering wheel, instrument panel and door finishers. (See “Seat belts” later in this section for instructions and precautions on seat belt usage.)

After turning the ignition switch to the ON position, the supplemental air bag warning light illuminates. The supplemental air bag warning light will turn off after about 7 seconds if the systems are operational.

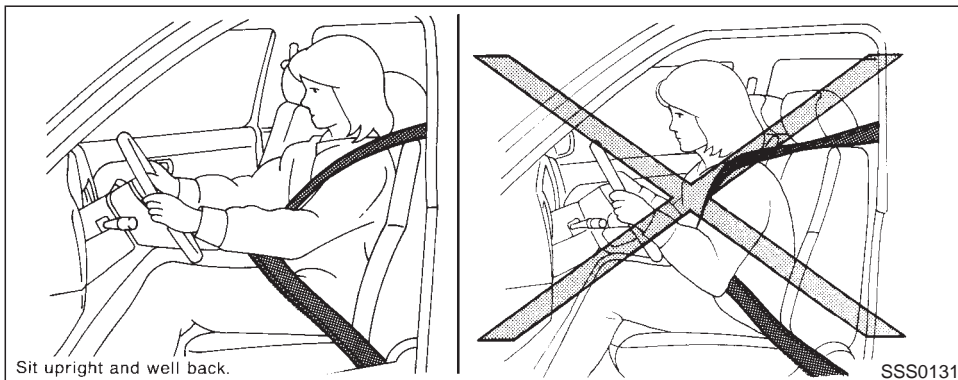

WARNING

- The supplemental front air bags ordinarily will not inflate in the event of a side impact, rear impact, roll over, or lower severity frontal collision. Always wear your seat belts to help reduce the risk or severity of injury in various kinds of accidents.
- The seat belts and the supplemental front air bags are most effective when

you are sitting well back and upright in the seat. Front air bags inflate with great force. If you are unrestrained, leaning forward, sitting sideways or out of position in any way, you are at greater risk of injury or death in a crash. You may also receive serious or fatal injuries from the supplemental front air bag if you are up against it when it inflates. Always sit back against the seatback and as far away as practical from the steering wheel

or instrument panel. Always use the seat belts.

- The driver and front passenger seat belt buckles are equipped with sensors that detect if the seat belts are fastened. The air bag system monitors the severity of a collision and then inflates the air bags based on belt usage. Failure to properly wear seat belts can increase the risk or severity of injury in an accident.
- Keep hands on the outside of the steering wheel. Placing them inside the steering wheel rim could increase the risk that they are injured when the supplemental front air bag inflates.



Sit upright and well back.

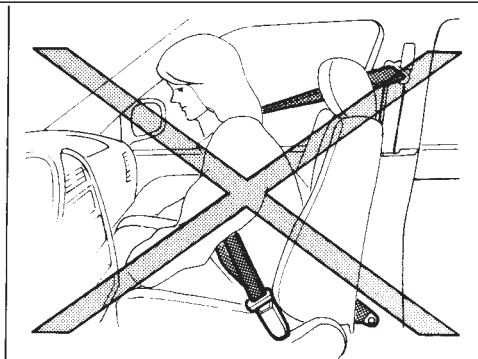

SSS0132

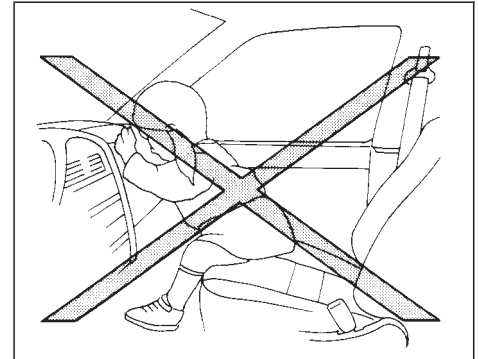

SSS0006

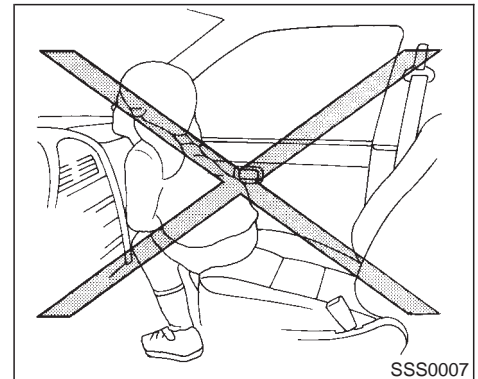

SSS0007

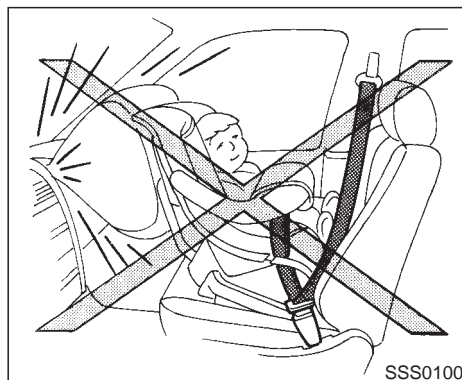
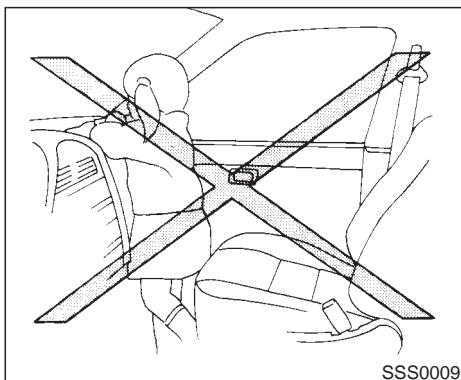
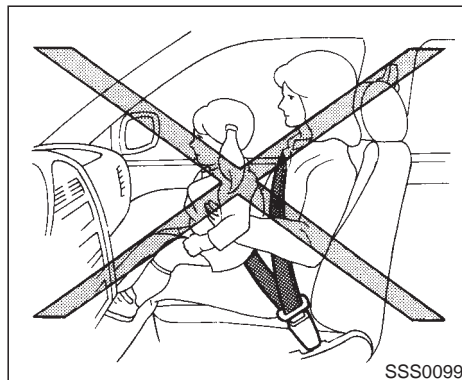
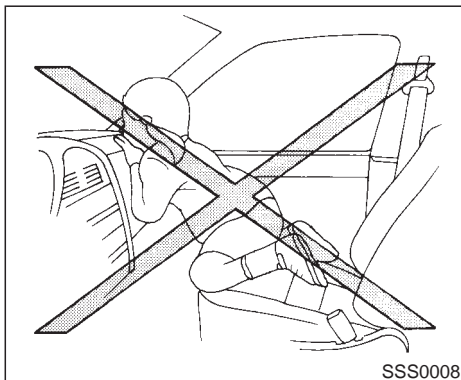

WARNING

- Never let children ride unrestrained or extend their hands or face out of the window. Do not attempt to hold them in your lap or arms. Some examples of dangerous riding positions are shown in the previous illustrations. Preteens and children should be properly restrained in the rear seat if possible.
- Children may be severely injured or killed when the supplemental front air bags, side air bags or curtain side-impact air bags inflate if they are not properly restrained. Preteens and children should be properly restrained in the rear seat if possible.
- Also never install a rear facing child restraint in the front seat. An inflating supplemental front air bag could seriously injure or kill your child. For additional information, see “Child restraints” later in this section.

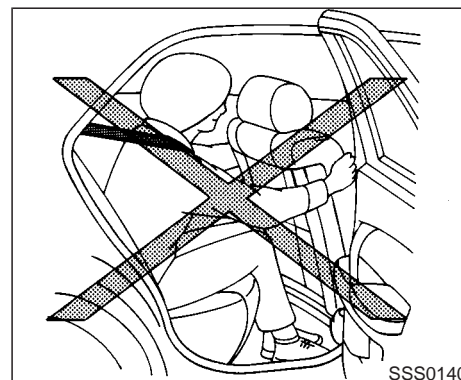
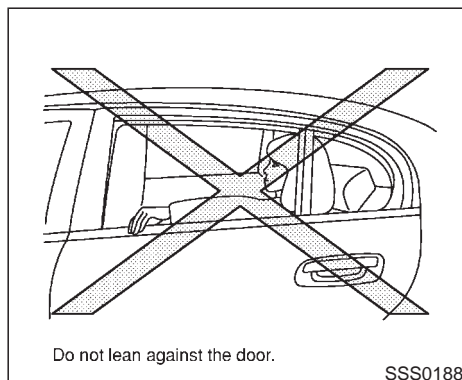
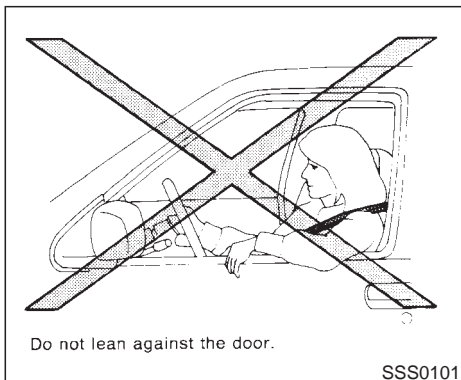

WARNING

Supplemental side air bag and curtain side-impact air bag:

- The supplemental side air bag and curtain side-impact air bag ordinarily will not inflate in the event of a frontal impact, rear impact, rollover or lower severity side collision. Always wear your seat belts to help reduce the risk or severity of injury in various kinds of accidents.

- The seat belts, the supplemental side air bag and curtain side-impact air bag are most effective when you are sitting well back and upright in the seat. The side air bag and curtain side-impact air bag inflate with great force. Do not allow anyone to place their hand, leg or face near the side air bag on the side of the seatback of the front seat or near the side roof rails. Do not allow anyone sitting in the front seat or rear outboard seats

to extend their hand out of the window or lean against the door. Some examples of dangerous riding positions are shown in the previous illustrations.

- When sitting in the rear seat, do not hold onto the seatback of the front seat. If the supplemental side air bag inflates, you may be seriously injured. Be especially careful with children, who should always be properly restrained.

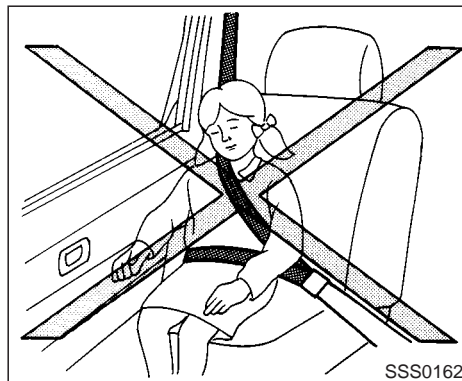
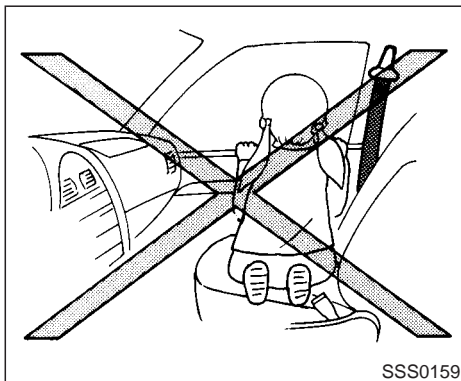

- Do not use seat covers on the front seatbacks. They may interfere with supplemental side air bag inflation.

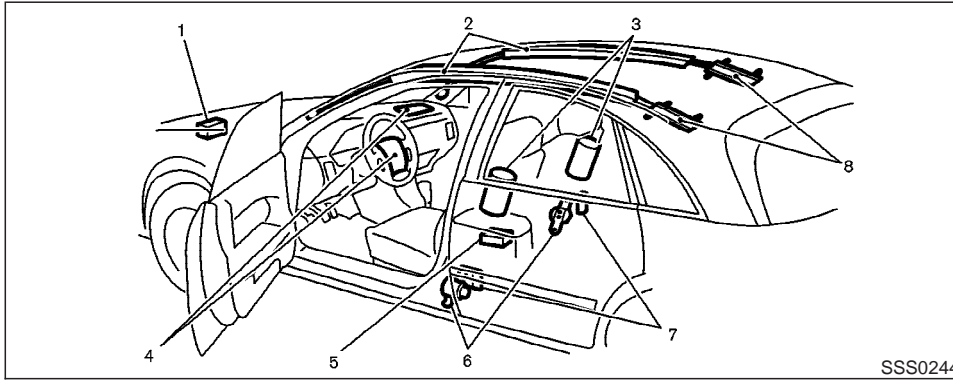

SSS0244

1. Crash zone sensor
2. Supplemental curtain side-impact air bags
3. Supplemental side air bag modules
4. Supplemental front air bag modules
5. Diagnosis sensor unit
6. Seat belt pre-tensioner retractor
7. Satellite sensors
8. Supplemental curtain side-impact air bag modules

Supplemental front air bag system

The driver supplemental air bag is located in

the center of the steering wheel; the front passenger supplemental air bag is mounted in the instrument panel above the glove box. These systems are designed to meet optional certification requirements under U.S. regulations. They are also permitted in Canada. The optional certification allows front air bags to be designed to inflate somewhat less forcefully than previously. **However, all of the information, cautions and warnings in this manual still apply and must be followed.** The front air bags are designed to inflate in higher severity frontal collisions, although they may inflate if the forces in another type of collision are similar to those of a higher severity frontal

impact. They may not inflate in certain frontal collisions. Vehicle damage (or lack of it) is not always an indication of proper supplemental air bag operation.

The supplemental air bag system has dual stage inflators for both the driver and passenger air bags. The system monitors information from the crash zone sensor, the diagnosis sensor unit and seat belt buckle sensors that detect if the seat belts are fastened, inflator operation is based on the severity of a collision and whether the seat belts are being used. Only one front air bag may inflate in a crash, depending on the crash severity and whether the front occupants are belted or unbelted. This does not indicate improper performance of the system. If you have any questions about the performance of your air bag system, please contact your INFINITI dealer.

When the supplemental front air bag inflates, a fairly loud noise may be heard, followed by release of smoke. This smoke is not harmful and does not indicate a fire. Care should be taken not to inhale it, as it may cause irritation and choking. Those with a history of a breathing condition should get fresh air promptly.

Supplemental front air bags, along with the use of seat belts, help to cushion the impact force on the face and chest of the front occu-

pants. They can help save lives and reduce serious injuries. However, an inflating front air bag may cause facial abrasions or other injuries. Front air bags do not provide restraint to the lower body.

The seat belts should be correctly worn and the driver and passenger seated upright as far as practical away from the steering wheel or dashboard. The supplemental front air bags inflate quickly in order to help protect the front occupants. Because of this, the force of the front air bag inflating can increase the risk of injury if the occupant is too close to, or is against the air bag module during inflation. The air bag will deflate quickly after the collision is over.

After turning the ignition switch to the ON position, the supplemental air bag warning light illuminates. The supplemental air bag warning light will turn off after about 7 seconds if the system is operational.



WARNING

- Do not place any objects on the steering wheel pad or on the instrument panel. Also, do not place any objects between any occupant and the steer-

ing wheel or instrument panel. Such objects may become dangerous projectiles and cause injury if the supplemental front air bag inflates.

- Right after inflation, several air bag system components will be hot. Do not touch them; you may severely burn yourself.
- No unauthorized changes should be made to any components or wiring of the supplemental front air bag system. This is to prevent accidental inflation of the air bag or damage to the air bag system.
- Do not make unauthorized changes to your vehicle's electrical system, suspension system or front end structure. This could affect proper operation of the supplemental air bag system.
- Tampering with the supplemental front air bag system may result in serious personal injury. Tampering includes changes to the steering wheel and the instrument panel as-

sembly by placing material over the steering wheel pad, above the dashboard, or by installing additional trim material around the air bag system.

- Work around and on the supplemental front air bag system should be done by an INFINITI dealer. Installation of electrical equipment should also be done by an INFINITI dealer. The yellow and orange Supplemental Restrain System (SRS) wiring and connectors should not be modified or disconnected. Unauthorized electrical test equipment and probing devices should not be used on the air bag system.
- A cracked windshield should be replaced immediately by a qualified repair facility. A cracked windshield could affect inflation of the supplemental air bag system.
- The SRS wiring harness connectors are yellow and orange for easy identification.

When selling your vehicle, we request that you inform the buyer about the supplemental front air bag system and guide the buyer to the appropriate sections in this Owner's Manual.

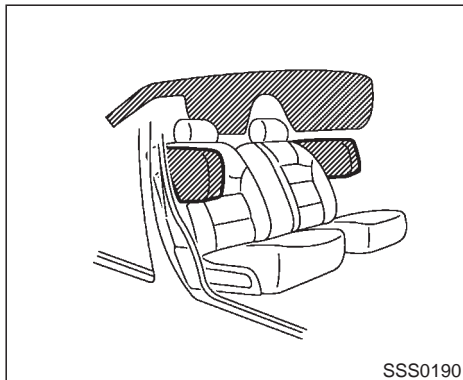

Supplemental side air bag and curtain side-impact air bag system

The supplemental side air bags are located in the outside of the seatback of the front seats. The supplemental curtain side-impact air bags are located in the side roof rails. These systems are designed to meet voluntary guidelines to help reduce the risk of injury to out-of-position occupants. **However, all of the information, cautions and warnings in this manual still apply and must be followed.** The supplemental side air bags and curtain side-impact air bags are designed to inflate in higher severity side collisions, although they

may inflate if the forces in another type of collision are similar to those of a higher severity side impact. They are designed to inflate on the side where the vehicle is impacted. They may not inflate in certain side collisions. Vehicle damage (or lack of it) is not always an indication of proper supplemental side air bag and curtain side-impact air bag operation.

When the supplemental side air bag and curtain side-impact air bag inflate, a fairly loud noise may be heard, followed by release of smoke. This smoke is not harmful and does not indicate a fire. Care should be taken not to inhale it, as it may cause irritation and choking. Those with a history of a breathing condition should get fresh air promptly.

Supplemental side air bags, along with the use of seat belts, help to cushion the impact force on the chest of the front occupants. Curtain side-impact air bags help to cushion the impact force to the head of occupants in the front and rear outboard seating positions. They can help save lives and reduce serious injuries. However, an inflating side air bag and curtain side-impact air bag may cause abrasions or other injuries. Supplemental side air bags and curtain side-impact air bags do not provide restraint to the lower body.

The seat belts should be correctly worn and the driver and passenger seated upright as far

as practical away from the side air bag. Rear seat passengers should be seated as far away as practical from the door finishers and side roof rails. The side air bags and curtain side-impact air bag inflate quickly in order to help protect the front occupants. Because of this, the force of the side air bag and curtain air bag inflating can increase the risk of injury if the occupant is too close to, or is against, these air bag modules during inflation. The side air bag and curtain air bag will deflate quickly after the collision is over.

After turning the ignition switch to the ON position, the supplemental air bag warning light illuminates. The air bag warning light will turn off after about 7 seconds if the systems are operational.



WARNING

- **Do not place any objects near the seatback of the front seats. Also, do not place any objects (an umbrella, bag, etc.) between the front door finisher and the front seat. Such objects may become dangerous projectiles and cause injury if the side air bag inflates.**

- **Right after inflation, several side air bag and curtain air bag system components will be hot. Do not touch them; you may severely burn yourself.**
- **No unauthorized changes should be made to any components or wiring of this side air bag and curtain side-impact air bag system. This is to prevent accidental inflation of the side air bag and curtain side-impact air bag or damage to the side air bag and curtain side-impact air bag system.**
- **Do not make unauthorized changes to your vehicle's electrical system, suspension system or side panel. This could affect proper operation of the supplemental side air bag and curtain side-impact air bag system.**
- **Tampering with the supplemental system may result in serious personal injury. For example, do not change the front seat by placing material near the seatback or by install-**

ing additional trim material, such as seat covers, around the side air bag.

- **Work around and on the side air bag and curtain side-impact air bag system should be done by an INFINITI dealer. Installation of electrical equipment should also be done by an INFINITI dealer. The SRS wiring harnesses* should not be modified or disconnected. Unauthorized electrical test equipment and probing devices should not be used on the side air bag system.**

* The SRS wiring harnesses are covered with yellow insulation either just before the harness connectors or over the complete harness for easy identification.

When selling your vehicle, we request that you inform the buyer about the side air bag and curtain side-impact air bag system and guide the buyer to the appropriate sections in this Owner's Manual.

Pre-tensioner seat belt system (For front seats)



WARNING

- The pre-tensioner seat belt cannot be reused after activation. It must be replaced together with the retractor as a unit.
- If the vehicle becomes involved in a frontal collision but the pre-tensioner is not activated, be sure to have the pre-tensioner system checked and, if necessary, replaced by your INFINITI dealer.
- No unauthorized changes should be made to any components or wiring of the pre-tensioner seat belt system. This is to prevent accidental activation of the pre-tensioner seat belt or damage to the pre-tensioner seat belt operation. Tampering with the pre-tensioner seat belt system may result in serious personal injury.
- Work around and on the pretensioner

system should be done by an INFINITI dealer. Installation of electrical equipment should also be done by an INFINITI dealer. Unauthorized electrical test equipment and probing devices should not be used on the pre-tensioner seat belt system.

- If you need to dispose of the pre-tensioner or scrap the vehicle, contact an INFINITI dealer. Correct pre-tensioner disposal procedures are set forth in the appropriate INFINITI Service Manual. Incorrect disposal procedures could cause personal injury.

The front seat pre-tensioner seat belt system activates in conjunction with the supplemental air bag systems. Working with the seat belt retractor, it helps tighten the seat belt when the vehicle becomes involved in certain types of collisions, helping to restrain front seat occupants.

The pre-tensioner is encased with the seat belt's retractor. These seat belts are used in the same way as conventional seat belts.

When the pre-tensioner seat belt activates,

smoke is released and a loud noise may be heard. The smoke is not harmful, but care should be taken not to inhale it as it may cause irritation and choking. Those with a history of a breathing condition should get fresh air promptly.

If any abnormality occurs in the pre-tensioner system, the supplemental air bag warning light  will not come on, will flash intermittently or will turn on for 7 seconds and remain on after the ignition switch has been turned to the ON or START position. In this case, the pre-tensioner seat belt may not function properly. They must be checked and repaired. Take your vehicle to the nearest authorized INFINITI dealer.

When selling your vehicle, we request that you inform the buyer about the pre-tensioner seat belt system and guide the buyer to the appropriate sections in this Owner's Manual.

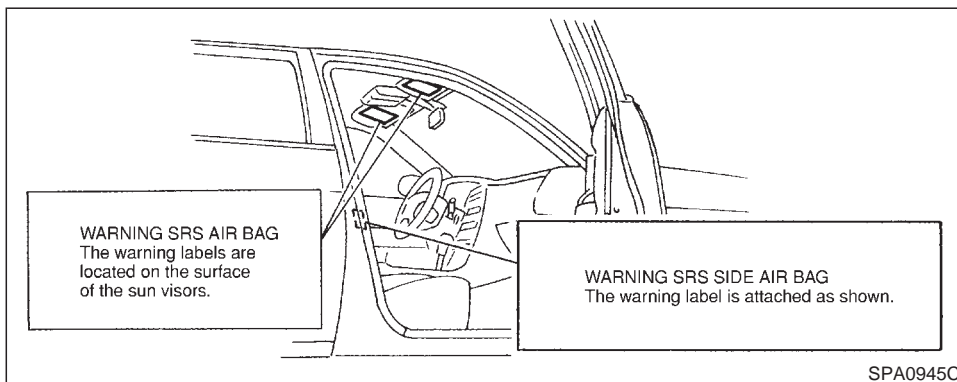

SUPPLEMENTAL AIR BAG WARNING LABELS

Warning labels about the supplemental air bag system are placed in the vehicle as shown in the illustration.



SUPPLEMENTAL AIR BAG WARNING LIGHT

The supplemental air bag warning light, displaying  in the instrument panel, monitors the circuits of the supplemental front air bag, supplemental side air bag and curtain side-impact air bag systems, and pre-tensioner seat belt. The circuits monitored by the air bag warning light are the diagnosis sensor unit, crash zone sensor, satellite sensors, front air bag modules, side air bag modules, curtain side-impact air bag modules, pre-tensioner seat belt and all related wiring.

After turning the ignition switch to the ON

position, the supplemental air bag warning light illuminates. The supplemental air bag warning light will turn off after about 7 seconds if the system is operational.

If any of the following conditions occur, the supplemental front air bag, supplemental side air bag and curtain side-impact air bag systems, and pre-tensioner seat belt need servicing:

- The supplemental air bag warning light remains on after approximately 7 seconds.
- The supplemental air bag warning light flashes intermittently.
- The supplemental air bag warning light does not come on at all.

Under these conditions, the supplemental front air bags, supplemental side air bags, curtain side-impact air bags and/or pre-tensioner seat belt may not operate properly. They must be checked and repaired. Take your vehicle to the nearest authorized INFINITI dealer.



WARNING

If the supplemental air bag warning light is on, it could mean that the supplemen-

tal front air bag, supplemental side air bag, curtain air bag systems and/or pre-tensioner seat belt will not operate in an accident. To help avoid injury to yourself or others, have your vehicle checked by an INFINITI dealer as soon as possible.

Repair and replacement procedure

The supplemental front air bags, supplemental side air bags, curtain side-impact air bags and pre-tensioner seat belt are designed to inflate on a one-time-only basis. As a reminder, unless it is damaged, the supplemental air bag warning light will remain illuminated after inflation has occurred. Repair and replacement of these systems should be done only by an INFINITI dealer.

When maintenance work is required on the vehicle, the supplemental front air bags, side air bags, curtain air bags, related parts and pre-tensioner seat belt should be pointed out to the person conducting the maintenance. The ignition switch should always be in the LOCK position when working under the hood or inside the vehicle.



WARNING

- Once the supplemental front air bag, side air bag or curtain side-impact air bag has inflated, the air bag module will not function again and must be replaced. Additionally, if any of the supplemental front air bags inflate, the activated pre-tensioner seat belts must also be replaced. The air bag module and pre-tensioner seat belt system should be replaced by an INFINITI dealer. The air bag modules and pre-tensioner seat belt system cannot be repaired.
- The supplemental front air bag and side air bag, curtain side-impact air bag systems and pre-tensioner seat belt system should be inspected by an INFINITI dealer if there is any damage to the front end or side portion of the vehicle.
- If you need to dispose of these supplemental systems or scrap the vehicle, contact an authorized INFINITI dealer.

Correct disposal procedures are set forth in the appropriate INFINITI Service Manual. Incorrect disposal procedures could cause personal injury.

SEAT BELTS

PRECAUTIONS ON SEAT BELT USAGE

If you are wearing your seat belt properly adjusted, and you are sitting upright and well back in your seat, your chances of being injured or killed in an accident and/or the severity of injury may be greatly reduced. INFINITI strongly encourages you and all of your passengers to buckle up every time you drive, even if your seating position includes a supplemental air bag.

Most states, provinces or territories require that seat belts be worn at all times when a vehicle is being driven.

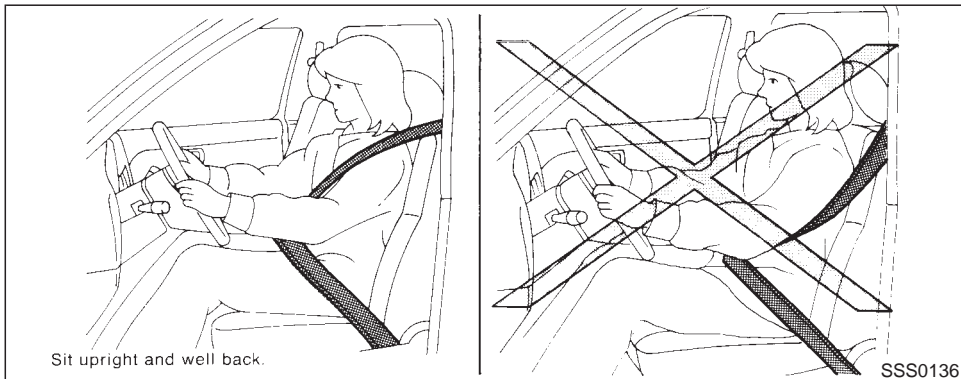

WARNING

- Every person who drives or rides in this vehicle should use a seat belt at all times. Children should be properly restrained in the rear seat and, if appropriate, in a child restraint.
- The belt should be properly adjusted to a snug fit. Failure to do so may reduce the effectiveness of the entire restraint system and increase the

chance or severity of injury in an accident. Serious injury or death can occur if the seat belt is not worn properly.

- Always route the shoulder belt over your shoulder and across your chest. Never run the belt behind your back under your arm or across your neck. The belt should be away from your face and neck, but not falling off your shoulder.

- Position the lap belt as low and snug as possible around the hips, not the waist. A lap belt worn too high could increase the risk of internal injuries in an accident.
- Be sure the seat belt tongue is securely fastened to the proper buckle.
- Do not wear the belt inside out or twisted. Doing so may reduce its effectiveness.
- Do not allow more than one person to use the same belt.
- Never carry more people in the vehicle than there are seat belts.
- If the seat belt warning light glows continuously while the ignition is turned ON with all doors closed and all seat belts fastened, it may indicate a malfunction in the system. Have the system checked by an INFINITI dealer.
- Once the pre-tensioner seat belt has activated, it cannot be reused and must be replaced together with the

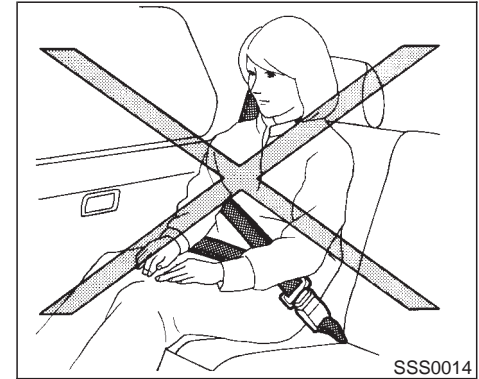
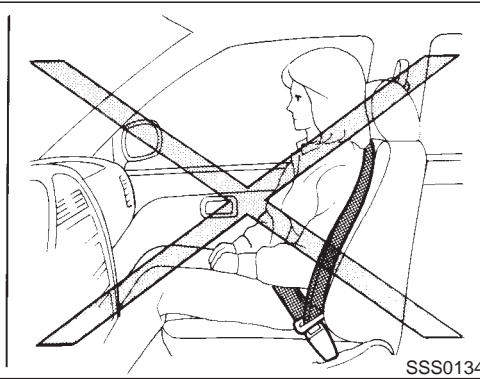
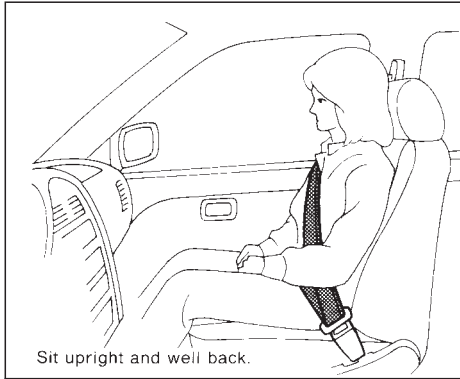

retractor. See your INFINITI dealer.

- Removal and installation of the pretensioner seat belt system components should be done by an INFINITI dealer.
- All seat belt assemblies including retractors and attaching hardware should be inspected after any collision by your INFINITI dealer. INFINITI recommends that all seat belt assemblies in use during a collision be replaced unless the collision was minor and the belts show no damage

and continue to operate properly. Seat belt assemblies not in use during a collision should also be inspected and replaced if either damage or improper operation is noted.

- All child restraints and attaching hardware should be inspected after any collision. Always follow the restraint manufacturer's inspection instructions and replacement recommendations. The child restraints should be replaced if they are damaged.

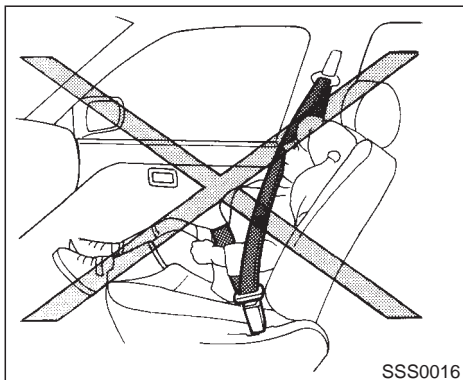

CHILD SAFETY

Children need adults to help protect them. They need to be properly restrained.

The proper restraint depends on the child's size. Generally, infants (up to about 1 year and less than 20 lb (9 kg) should be placed in rear facing child restraints. Front facing child restraints are available for children who outgrow rear facing child restraints.



WARNING

Infants and children need special protection. The vehicle's seat belts may not fit them properly. The shoulder belt may come too close to the face or neck. The lap belt may not fit over their small hip bones. In an accident, an improperly fitting seat belt could cause serious or fatal injury. Always use appropriate child restraints.

All US states and provinces of Canada require the use of approved child restraints for infants and small children. (See "Child restraints" later in this section.)

In addition, there are many types of child restraints available for larger children which should be used for maximum protection.

INFINITI recommends that all preteens and children be restrained in the rear seat. According to accident statistics, children are safer when properly restrained in the rear seat than in the front seat.

This is especially important because your vehicle has a supplemental restraint system (air bag system) for the front passen-

ger. See "Supplemental Restraint System" earlier in this section for precautions.

Infants and small children

INFINITI recommends that infants and small children be placed in child restraints that comply with Federal Motor Vehicle Safety Standards or Canadian Motor Vehicle Safety Standards. You should choose a child restraint that fits your vehicle and always follow the manufacturer's instructions for installation and use.

Larger children

Children who are too large for child restraint systems should be seated and restrained by the seat belts which are provided.

If the child's seating position has a shoulder belt that fits close to the face or neck, the use of a booster seat (commercially available) may help overcome this. The booster seat should raise the child so that the shoulder belt is properly positioned across the top, middle portion of the shoulder and the lap belt is low on the hips. The booster seat should fit the vehicle seat and have a label certifying that it complies with Federal Motor Vehicle Safety Standards or Canadian Motor Vehicle Safety Standards. Once the child has grown so the shoulder belt is no longer on or near the face

and neck, use the shoulder belt without the booster seat.



WARNING

Never let a child stand or kneel on any seat and do not allow a child in the cargo areas while the vehicle is moving. The child could be seriously injured or killed in an accident or a sudden stop.

PREGNANT WOMEN

INFINITI recommends that pregnant women use seat belts. The seat belt should be worn snug, and always position the lap belt as low as possible around the hips, not the waist. Place the shoulder belt over your shoulder and across your chest. Never run the lap/shoulder belt over your abdominal area. Contact your doctor for specific recommendations.

INJURED PERSONS

INFINITI recommends that injured persons use seat belts, depending on the injury. Check with your doctor for specific recommendations.

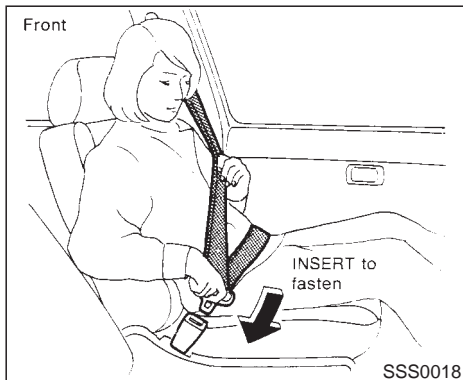

THREE-POINT TYPE SEAT BELT WITH RETRACTOR



WARNING

- Every person who drives or rides in this vehicle should use a seat belt at all times.
- Do not ride in a moving vehicle when the seatback is reclined. This can be dangerous. The shoulder belt will not be against your body. In an accident

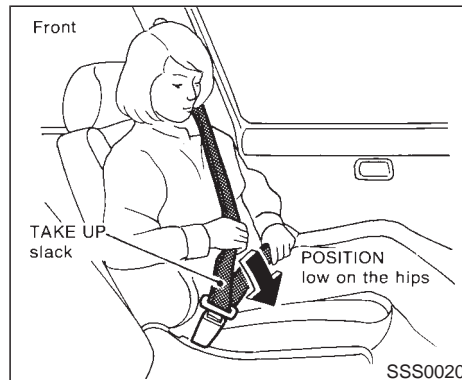

you could be thrown into it and receive neck or other serious injuries. You could also slide under the lap belt and receive serious internal injuries.

- For most effective protection when the vehicle is in motion, the seat should be upright. Always sit well back in the seat and adjust the seat belt properly.



fully retracted position, firmly pull the belt and release it. Then smoothly pull the belt out of the retractor.

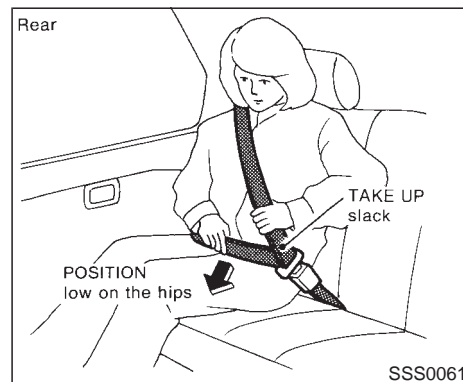

Fastening the seat belts

1. Adjust the seat. See “Seats” earlier in this section.
 2. Slowly pull the seat belt out of the retractor and insert the tongue into the buckle until it clicks. (For additional information regarding the rear center seat belt, see “Setting center seat belt”.)
- **The retractor is designed to lock during a sudden stop or on impact. A slow pulling motion will permit the belt to move, and allow you some freedom of movement in the seat.**
 - **If the seat belt cannot be pulled from its**

3. Position the lap belt portion **low and snug on the hips** as shown.

4. Pull the shoulder belt portion toward the retractor to take up extra slack. Be sure the shoulder belt is routed over your shoulder and across your chest.

The front passenger and rear seat belts have a cinching mechanism for child restraint installation. It is referred to as the automatic locking mode.

When the cinching mechanism is activated the seat belt cannot be withdrawn again until the seat belt tongue is detached from the buckle

and fully retracted. For additional information, see “Child restraints” later in this section.

The automatic locking mode should be used only for child restraint installation. During normal seat belt use by a passenger, the locking mode should not be activated. If it is activated it may cause uncomfortable seat belt tension.



WARNING

When fastening the seat belts, be certain that seatbacks are completely secured in the latched position. If they are not completely secured, passengers may be injured in an accident or sudden stop.

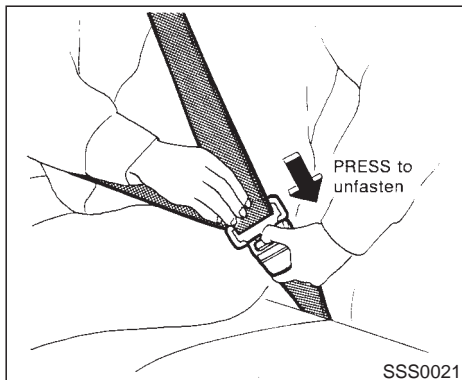

Unfastening the seat belts

To unfasten the belt, press the button on the buckle. The seat belt will automatically retract.

Checking seat belt operation

Your seat belt retractors are designed to lock belt movement using two separate methods:

- when the belt is pulled quickly from the retractor.
- when the vehicle slows down rapidly.

You can check their operation as follows:

- grasp the shoulder belt and pull quickly

forward. The retractor should lock and restrict further belt movement.

If the retractor does not lock during this check or if you have any questions about belt operation, see your INFINITI dealer.

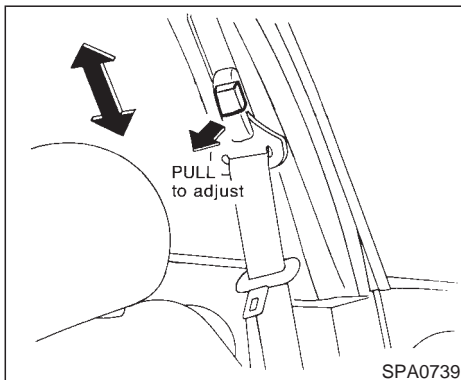

Shoulder belt height adjustment (For front seats)

The shoulder belt anchor height should be adjusted to the position best suited for you. (See “Precautions on seat belt usage” earlier in this section.) To lower, pull the release button, and then move the shoulder belt anchor to the desired position, so that the belt passes over the shoulder. Release the adjustment button to lock the shoulder belt anchor into position.

To raise, move the adjuster up to the desired position while pulling the button.



WARNING

- After adjustment, release the adjustment button and try to move the shoulder belt down to make sure it is securely fixed in position.
- The shoulder belt anchor height should be adjusted to the position best for you. Failure to do so may reduce the effectiveness of the entire restraint system and increase the chance or severity of injury in an accident.

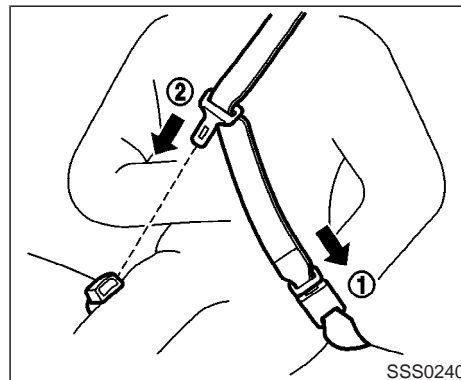

REAR CENTER SEAT BELT

The rear center seat belt has a connector tongue ① and a seat belt tongue ②. Both the connector tongue and the seat belt tongue must be securely latched for proper seat belt operation.

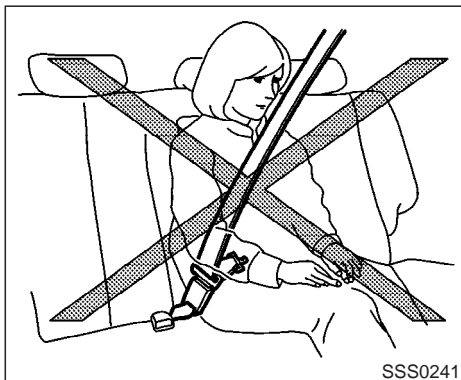

WARNING

- Always fasten the connector tongue and the seat belt in the order shown.
- Always make sure both the connector tongue and the seat belt tongue are secured when using the seat belt. Do not use it with only the seat belt tongue attached. This could result in serious personal injury in case of an accident or a sudden stop.

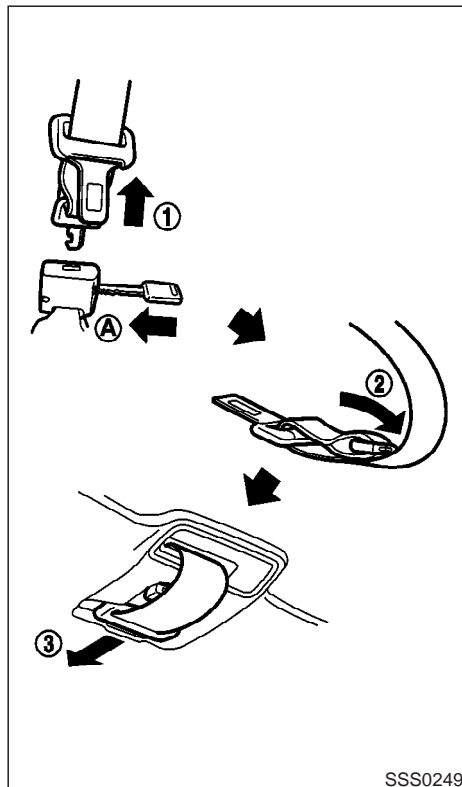

Stowing rear center seat belt

When folding down the rear seat, the rear center seat belt can be retracted into a stowed position as follows:

1. Release the connector tongue (1) by inserting a suitable tool such as key into the connector buckle (A).
2. Fold the connector as illustrated (2).
3. Then secure the connector tongue into the retractor base (3) in the ceiling.

WARNING

- Do not unfasten the rear center seat belt connector except when folding down the rear seat.
- When attaching the rear center seat belt connector, be certain that the seatbacks are completely secured in the latched position and the rear center seat belt connector is completely secured.
- If the rear center seat belt connector

and the seatbacks are not secured in the correct position, serious personal injury may result in an accident or sudden stop.

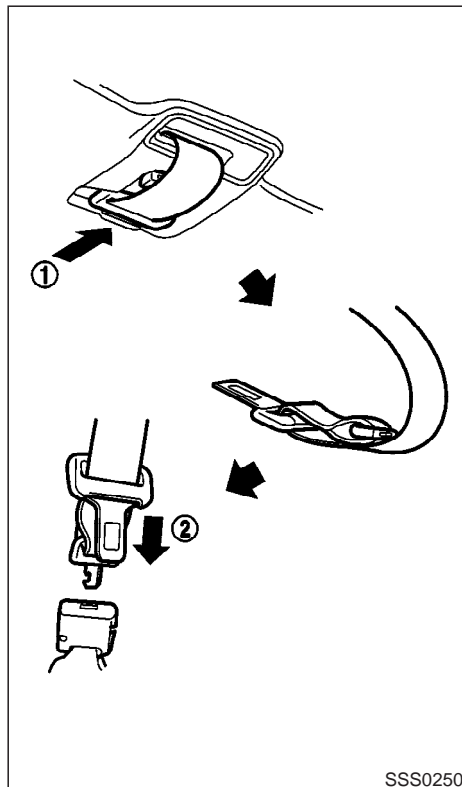

Attaching rear center seat belt

Always be sure the rear center seat belt connector tongue and connector buckle are attached. Disconnect only when folding down the rear seat.

To connect the buckle:

1. Pull out the seat belt tongue from the retractor base (1) in the ceiling.
2. Pull the seat belt and secure the connector buckle until it clicks (2).

The center seat belt connector tongue and buckle are indicated by the “▼” and “▲” mark.

The center seat belt connector tongue can be attached only into the rear center seat belt connector buckle.

To fasten the seat belt, see “Fastening the seat belt” earlier in this section.



WARNING

- Do not unfasten the rear center seat belt connector except when folding down the rear seat.

- When attaching the rear center seat belt connector, be certain that the seatbacks are completely secured in the latched position and the rear center seat belt connector is completely secured.
- If the rear center seat belt connector and the seatbacks are not secured in the correct position, serious personal injury may result in an accident or sudden stop.

SEAT BELT EXTENDERS

If, because of body size or driving position, it is not possible to properly fit the lap-shoulder belt and fasten it, an extender is available. The extender adds approximately 8 inches (200 mm) of length and may be used for either the driver or front passenger seating position. See your INFINITI dealer for assistance if the extender is required.



WARNING

- Only INFINITI belt extenders, made by the same company which made the original equipment belts, should be used with INFINITI belts.
- Adults and children who can use the standard seat belt should not use an extender. Such unnecessary use could result in serious personal injury in the event of an accident.
- Never use seat belt extenders to install child restraints. If the child restraint is not secured properly, the child could be seriously injured in a collision or a sudden stop.

SEAT BELT MAINTENANCE

- To clean the seat belt webbings, apply a mild soap solution or any solution recommended for cleaning upholstery or carpets. Then brush the webbing, wipe it with a cloth and allow it to dry in the shade. Do not allow the seat belts to retract until they are completely dry.

- If dirt builds up in the shoulder belt guide of the seat belt anchors, the seat belts may retract slowly. Wipe the shoulder belt guide with a clean, dry cloth.
- Periodically check to see that the seat belt and the metal components such as buckles, tongues, retractors, flexible wires and anchors work properly. If loose parts, deterioration, cuts or other damage on the webbing is found, the entire belt assembly should be replaced.

CHILD RESTRAINTS

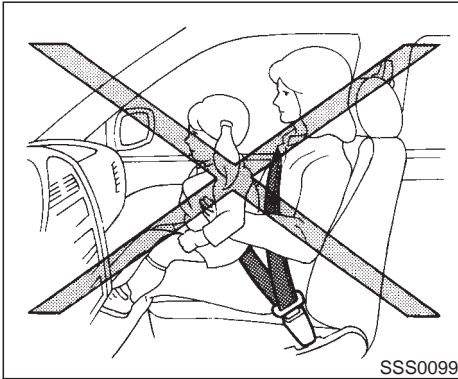

PRECAUTIONS ON CHILD RESTRAINTS

WARNING

- Infants and small children should always be placed in an appropriate child restraint while riding in the vehicle. Failure to use a child restraint can result in serious injury or death.
- Infants and small children should never be carried on your lap. It is not

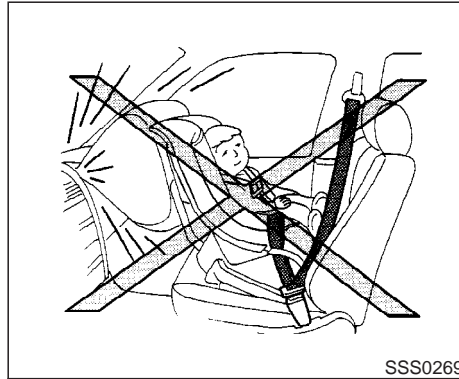

possible for even the strongest adult to resist the forces of a severe accident. The child could be crushed between the adult and parts of the vehicle. Also, do not put the same seat belt around both your child and yourself.

- Never install a rear facing child restraint in the front seat. An inflating supplemental air bag could seriously injure or kill your child. A rear facing child restraint must only be used in the rear seat.

- **INFINITI recommends that the child restraint be installed in the rear seat. According to accident statistics, children are safer when properly restrained in the rear seat than in the front seat.**
- **An improperly installed child restraint could lead to serious injury or death in an accident.**

In general, child restraints are designed to be installed with the lap portion of a three-point type seat belt. In addition, this vehicle is equipped with a universal child restraint lower anchor system, referred to as the LATCH (Lower Anchors and Tethers for Children) system. Some child restraints include two rigid or webbing-mounted attachments that can be connected to these lower anchors. For details, see “LATCH (Lower Anchors and Tethers for Children) SYSTEM” later in this section.

Child restraints for infants and children of various sizes are offered by several manufacturers. When selecting any child restraint, keep the following points in mind:

- choose only a restraint with a label certifying that it complies with Federal Motor Vehicle Safety Standard 213 or Canadian Motor Vehicle Safety Standard 213.

- check the child restraint in your vehicle to be sure it is compatible with the vehicle's seat and seat belt system.
- if the child restraint is compatible with your vehicle, place your child in the child restraint and check the various adjustments to be sure the child restraint is compatible with your child. Always follow all recommended procedures.

All US states and Canadian provinces require that infants and small children be restrained in approved child restraints at all times while the vehicle is being operated.



WARNING

- Improper use of a child restraint can result in increased injuries for both the infant or child and other occupants in the vehicle.
- Follow all of the child restraint manufacturer's instructions for installation and use. When purchasing a child restraint, be sure to select one which will fit your child and vehicle. It may

not be possible to properly install some types of child restraints in your vehicle.

- If the child restraint is not anchored properly, the risk of a child being injured in a collision or a sudden stop greatly increases.
- Adjustable seatbacks should be positioned to fit the child restraint, but as upright as possible.
- After attaching the child restraint, test it before you place the child in it. Tilt it from side to side. Try to tug it forward and check to see if the belt holds the restraint in place. The child restraint should not move more than 1 inch (25 mm). If the restraint is not secure, tighten the belt as necessary, or put the restraint in another seat and test it again.
- For a front facing child restraint, check to make sure the shoulder belt does not go in front of the child's face or neck. If it does, put the shoulder belt behind the child restraint. If you

must install a front facing child restraint in the front seat, see instructions later in this section.

- When your child restraint is not in use, store it in the trunk or keep it secured with a seat belt to prevent it from being thrown around in case of a sudden stop or accident.



CAUTION

Remember that a child restraint left in a closed vehicle can become very hot. Check the seating surface and buckles before placing your child in the child restraint.

INSTALLATION ON REAR SEAT OUTBOARD OR CENTER POSITIONS



WARNING

- The three-point belt on your vehicle is equipped with a locking mode retractor which must be used when installing a child restraint.
- Failure to do so will result in the child restraint not being properly secured. It could tip over or otherwise be unsecured and cause injury to the child in a sudden stop or collision.

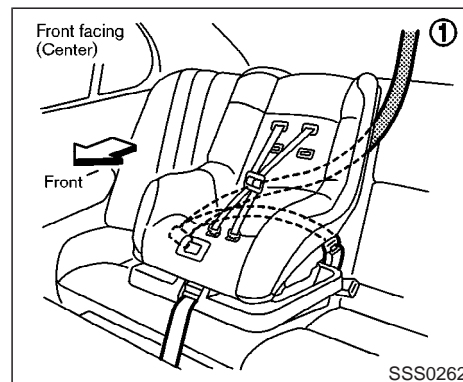
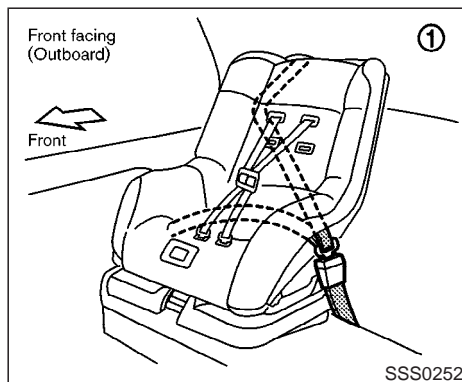

Front facing

When you install a child restraint in a rear outboard or center seat, follow these steps:

1. Position the child restraint on the seat. It can be placed in a front facing direction, depending on the size of the child. Adjust the head restraint to its highest position or remove it if the child restraint uses a top tether strap. Always follow the restraint manufacturer's instructions.

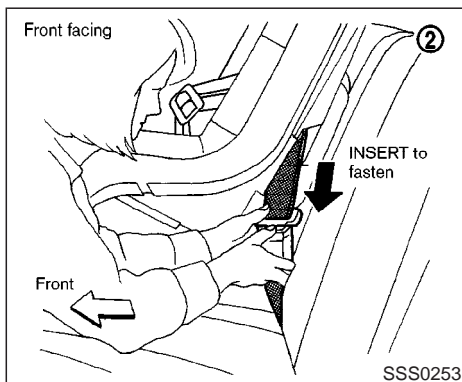

2. Route the seat belt tongue through the child restraint and insert it into the buckle until you hear and feel the latch engage. Be sure to follow the child restraint manufacturer's instructions for belt routing.

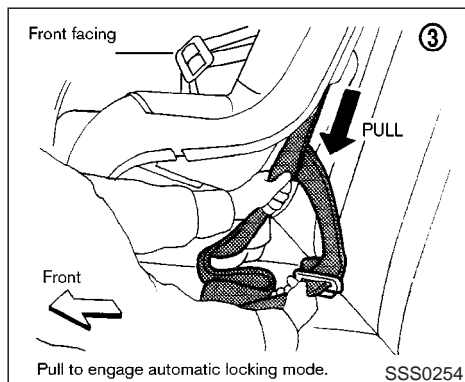

3. Pull on the shoulder belt until all of the belt is fully extended. At this time, the belt retractor is in the automatic locking mode (child restraint mode). It reverts back to emergency locking mode when the belt is fully retracted.

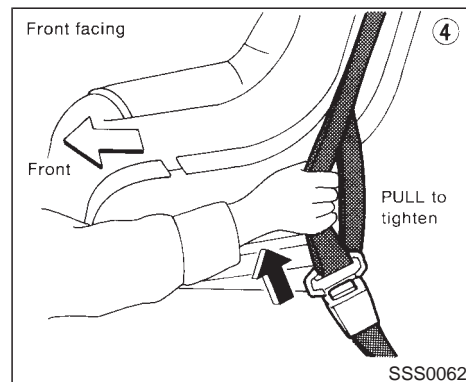

4. Allow the belt to retract. Pull up on the belt to remove any slack in the belt.

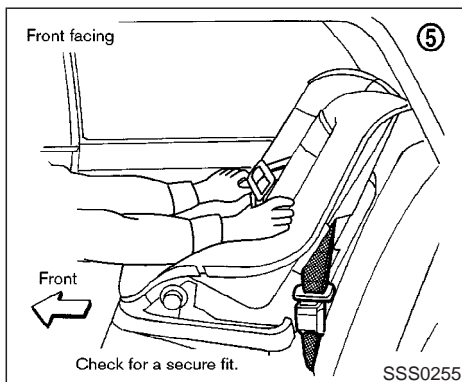

After the child restraint is removed and the seat belt is allowed to wind back into the retractor, the automatic locking mode (child restraint mode) is canceled; the seat belt only locks during a sudden stop or impact.

5. Before placing the child in the child restraint, use force to tilt the child restraint from side to side, and tug it forward to make sure that it is securely held in place. It should not move more than 1 inch (25 mm).
6. Check that the retractor is in the automatic locking mode by trying to pull more belt out of the retractor. If you cannot pull any more belt webbing out of the retractor, the belt is in the automatic locking mode.
7. Check to make sure that the child restraint is properly secured prior to each use. If the belt is not locked, repeat steps 3 through 6.

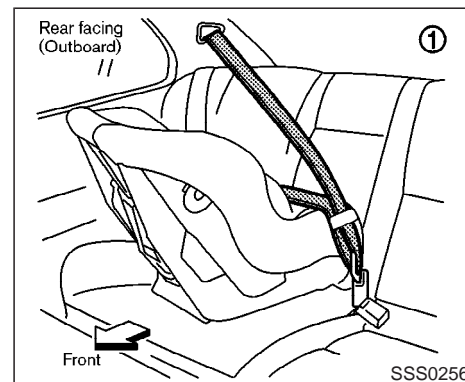

Rear facing

When you install a child restraint in a rear outboard or center seat, follow these steps:

1. Position the child restraint on the seat. The direction of the child restraint depends on the type of the child restraint and the size of the child. Always follow the restraint manufacturer's instructions.

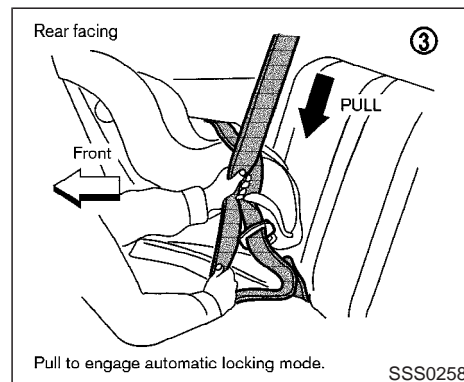
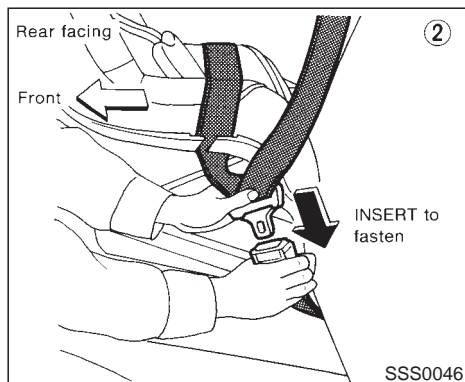
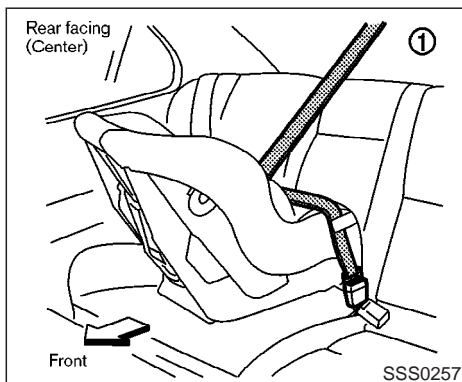

2. Route the seat belt tongue through the child restraint and insert it into the buckle until you hear and feel the latch engage. Be sure to follow the child restraint manufacturer's instructions for belt routing.
3. Pull on the shoulder belt until all of the belt is fully extended. At this time, the belt retractor is in the automatic locking mode (child restraint mode). It reverts back to emergency locking mode when the belt is fully retracted.

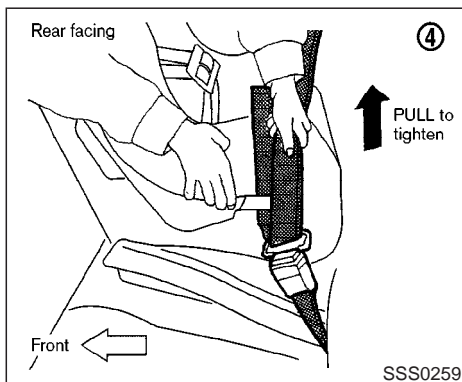

4. Allow the belt to retract. Pull up on the belt to remove any slack in the belt.

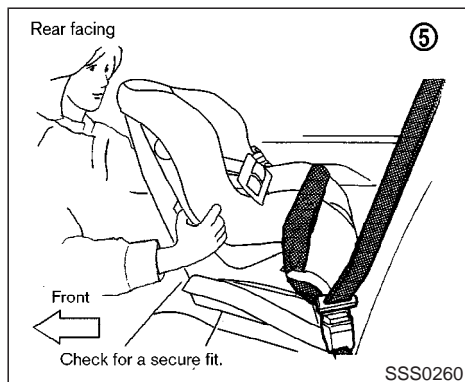

5. Before placing the child in the child restraint, use force to tilt the child restraint from side to side, and tug it forward to make sure that it is securely held in place. It should not move more than 1 inch (25 mm).
6. Check that the retractor is in the automatic locking mode by trying to pull more belt out of the retractor. If you cannot pull any more belt webbing out of the retractor, the belt is in the automatic locking mode.
7. Check to make sure that the child restraint is properly secured prior to each use. If the belt is not locked, repeat steps 3 through 6.

After the child restraint is removed and the seat belt is allowed to wind back into the retractor, the automatic locking mode (child restraint mode) is canceled; the seat belt only locks during a sudden stop or impact.

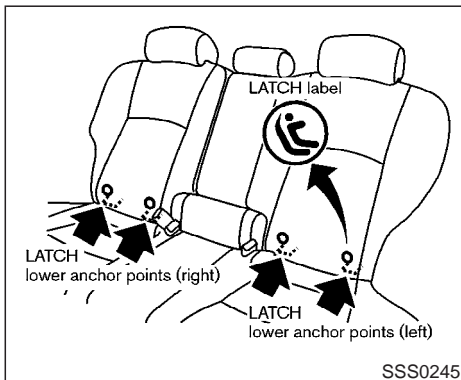

LATCH (LOWER ANCHORS AND TETHERS FOR CHILDREN) SYSTEM

WARNING

- **Attach LATCH system compatible child restraints only at the locations shown. If a child restraint is not secured properly, your child could be seriously injured or killed in an accident.**

- **Do not secure a child restraint in the center rear seating position using the child restraint lower anchors. The child restraint will not be secured properly.**
- **The LATCH system anchors are designed to withstand only those loads imposed by correctly fitted child restraints. Under no circumstance are they to be used for adult seat belts or harnesses.**

Some child restraints include two rigid or webbing-mounted attachments that can be connected to two anchors located at certain seating positions in your vehicle. This system is known as the LATCH (Lower Anchors and Tethers for Children) system. This system may also be referred to as the ISOFIX or ISOFIX compatible system. With this system, you do not have to use a vehicle seat belt to secure the child restraint. Your vehicle is equipped with special anchor points that are used with LATCH system compatible child restraints. Check your child restraint for a label stating that it is compatible with the LATCH system. This information may also be in the child restraint owner's manual. If you have such a

child restraint, refer to the illustration for the rear seating positions equipped with LATCH system anchors which can be used to secure the child restraint.

The LATCH system anchors are located at the rear of the seat cushion near the seatback. A label is attached to the seatback to help you locate the LATCH system anchors.

Some child restraints may also require the use of a top tether strap. See "Top tether strap child restraint" later in this section for installation instructions.

When installing a child restraint, carefully read and follow the instructions in this manual and those supplied with the child restraint.

When you install a LATCH system compatible child restraint to the lower anchor attachments in the rear seat, follow these steps.

WARNING

Inspect the lower anchors by inserting your fingers into the lower anchor area and feeling to make sure there are no obstructions over the LATCH system anchors, such as seat belt webbing or seat cushion material. The child re-

straint will not be secured properly if the LATCH system anchors are obstructed.

1. To install the LATCH system compatible child restraint, adjust the height of the child restraint LATCH system anchor attachments to the anchor points on the rear seat.
2. Insert the anchor attachments into the anchor points. If the child restraint is equipped with a top tether, see “Top tether strap child restraint” later in this section for installation instructions.
3. After attaching the child restraint and before placing the child in it, use force to tilt the child restraint from side to side and tug it forward to make sure that the child restraint is securely held in place. It should not move more than 1 inch (25 mm)
4. Check to make sure that the child restraint is properly secured prior to each use.

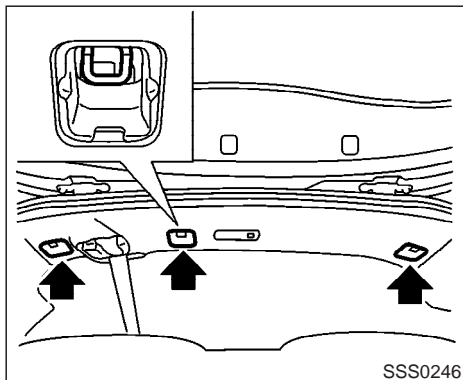

TOP TETHER STRAP CHILD RESTRAINT



WARNING

- **The child restraint anchor point is designed to withstand only those loads imposed by correctly fitted child restraints. Under no circumstance is it to be used for adult seat belts or harnesses.**
- **After removing a rear seat head re-**

straint for top tether installation, store it securely to prevent it from causing injury to passengers or damage to the vehicle in case of sudden braking or an accident. Always replace it and adjust properly when top tether is no longer in use.

If your child restraint has a top tether strap, it must be secured to the anchor point provided behind its position.

First, adjust the seatback so that it is upright. Then secure the child restraint with the rear seat belt or the LATCH system (outboard positions), as applicable. Remove the anchor cover from the anchor point as illustrated. Keep the removed cover in a secure place to prevent loss or damage.

Remove the head restraint from the seatback. Store it in a secure place. Position the top tether strap over the top of the seatback and secure it to the tether anchor bracket that provides the straightest installation. Tighten the tether strap according to the manufacturer's instruction to remove any slack.

For best child restraint fit, see the child restraint installation instructions in this section

and the child restraint manufacturer's instructions.

Anchor point locations

Anchor points are located on the ceiling above the luggage room.

If you have any questions when installing a top strap child restraint on the rear seat, consult your INFINITI dealer for details.

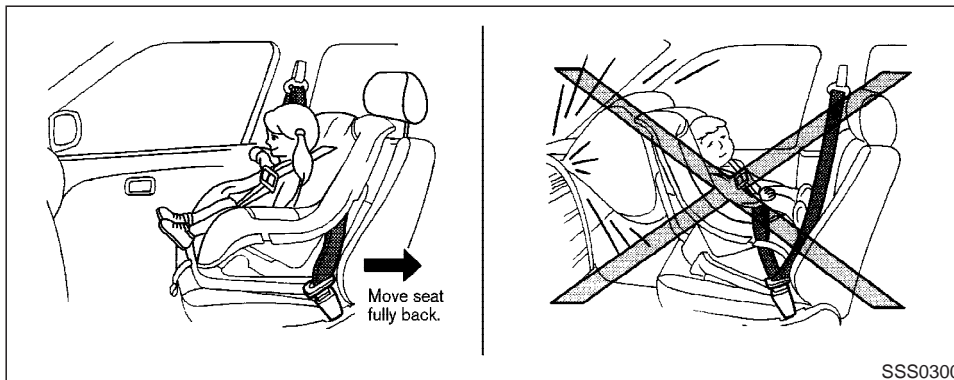

INSTALLATION ON FRONT PASSENGER SEAT

WARNING

- Never install a rear facing child restraint in the front passenger seat. Supplemental air bags inflate with great force. A rear facing child restraint could be struck by the supplemental air bag in a crash and could seriously injure or kill your child.

- INFINITI recommends that child restraints be installed in the rear seat. However, if you must install a front facing child restraint in the front passenger seat, move the passenger seat to the rearmost position.
- A child restraint with a top tether strap should not be used in the front passenger seat.
- The three-point belt in your vehicle is equipped with a locking mode retractor which must be used when install-

ing a child restraint.

- Failure to use the retractor's locking mode will result in the child restraint not being properly secured. The child restraint could tip over or otherwise be unsecured and cause injury to the child in a sudden stop or collision.

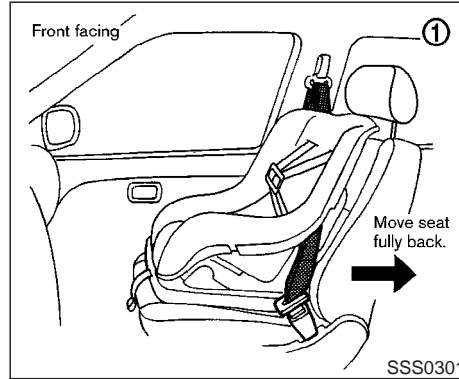

Front facing

If you must install a child restraint in the front seat, follow these steps:

1. Position the child restraint on the front passenger seat. **It should be placed in a front facing direction only.** Move the seat to the rearmost position. Adjust the head restraint to its highest position. Always follow the child restraint manufacturer's instructions. **Child restraints for infants must be used in the rear facing direction and therefore must not be used in the front seat.**

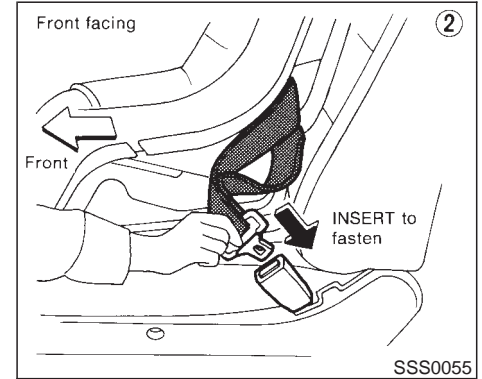

2. Route the seat belt tongue through the child restraint and insert it into the buckle until you hear and feel the latch engage. Be sure to follow the child restraint manufacturer's instructions for belt routing.

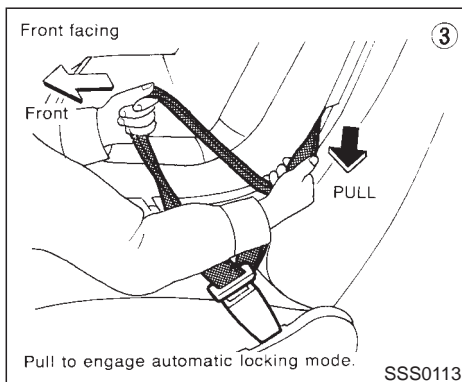

3. Pull on the shoulder belt until all of the belt is fully extended. At this time, the belt retractor is in the automatic locking mode (child restraint mode). It reverts back to emergency locking mode when the belt is fully retracted.

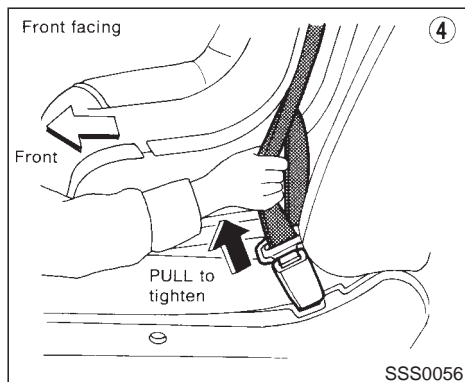

4. Allow the belt to retract. Pull up on the belt to remove any slack in the belt.

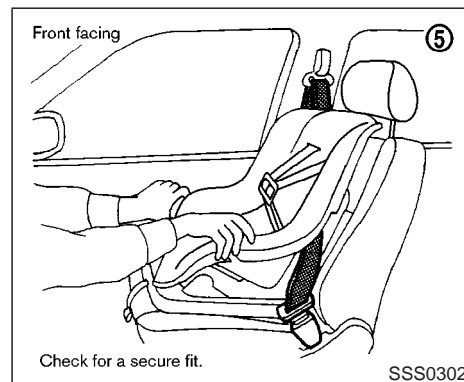

5. Before placing the child in the child restraint, use force to tilt the child restraint from side to side, and tug it forward to make sure that it is securely held in place. It should not move more than 1 inch (25 mm).

6. Check that the retractor is in the automatic locking mode by trying to pull more belt out of the retractor. If you cannot pull any more belt webbing out of the retractor, the belt is in the automatic locking mode.

7. Check to make sure that the child restraint is properly secured prior to each use. If the lap belt is not locked, repeat steps 3 through 6.

After the child restraint is removed and the seat belt is allowed to wind back into the retractor, the automatic locking mode (child restraint mode) is canceled; the seat belt only locks during a sudden stop or impact.

MEMO

2 Instruments and controls

Instrument panel	2-2	Turn signal switch	2-25
Meters and gauges	2-3	Fog light switch (if so equipped)	2-25
Speedometer and odometer	2-4	Hazard warning flasher switch	2-25
Tachometer	2-4	Horn	2-26
Engine coolant temperature gauge	2-5	Heated seats (if so equipped)	2-26
Fuel gauge	2-5	Snow mode switch	2-27
Compass display	2-6	Vehicle dynamic control (VDC) off switch	2-28
Warning/indicator lights and audible reminders	2-9	Clock	2-28
Checking bulbs	2-9	Adjusting the time	2-28
Warning lights	2-9	Power outlet	2-29
Indicator lights	2-14	Cigarette lighter and ashtray	2-30
Audible reminders	2-15	Storage	2-31
Security systems	2-16	Sunglasses holder	2-31
Vehicle security system	2-16	Cup holders	2-31
Infiniti Vehicle Immobilizer System	2-17	Glove box	2-32
Windshield wiper and washer switch	2-19	Console box	2-33
Rear window wiper and washer switch	2-19	Card holder	2-34
Rear window and outside mirror defroster switch	2-20	Cargo net (if so equipped)	2-34
Headlight and turn signal switch	2-20	Windows	2-35
Xenon headlights	2-20	Power windows	2-35
Headlight switch	2-21	Sunroof (if so equipped)	2-36
Daytime running light system (Canada only)	2-24	Automatic sunroof	2-36
Instrument brightness control	2-24	Interior light	2-38
		Interior light	2-38

Map lights	2-38
Rear personal light	2-39
Vanity mirror light	2-40
HomeLink® universal transceiver (if so equipped)	2-40
Programming HomeLink®	2-41
Programming HomeLink® for Canadian customers	2-42

Operating the HomeLink® Universal transceiver	2-42
Programming trouble-diagnosis	2-42
Clearing the programmed information	2-43
Reprogramming a single HomeLink® button	2-43
If your vehicle is stolen	2-43



INSTRUMENT PANEL

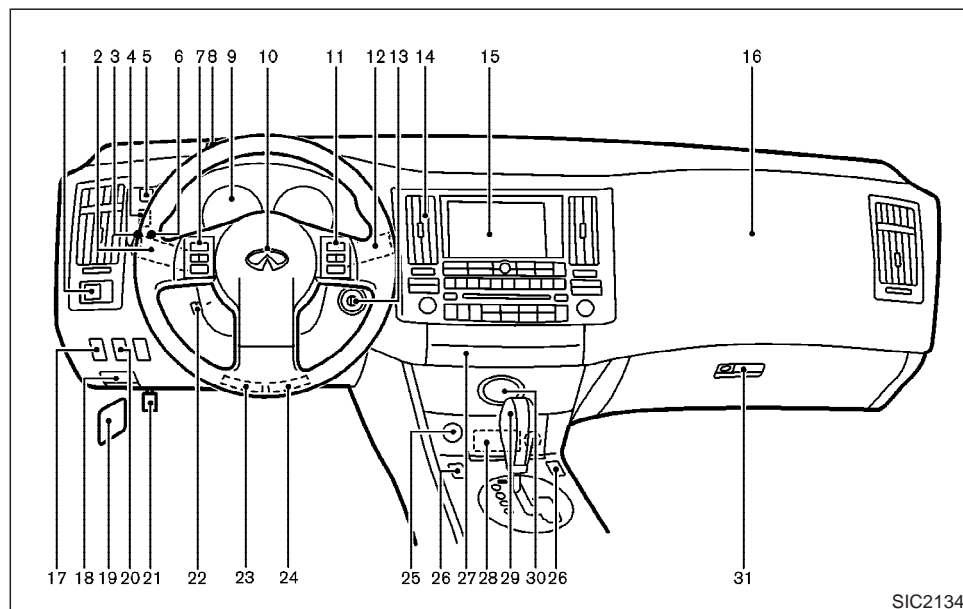

1. Outside mirror remote control (P.3-32)
2. Headlight, fog light and turn signal switch (P.2-20)
3. Trip odometer reset knob (P.2-4)
4. Instrument brightness control switch (P.2-24)

5. Headlight aiming control switch (P.2-23)
6. Trip odometer select knob (P.2-4)
7. Steering switch for Audio (P.4-33)
8. Security indicator light (P.2-18)
9. Meters and gauges (P.2-3)
10. Driver supplemental air bag (P.1-19)

11. Cruise control main/set switch (P.5-16) or Intelligent cruise control switch (if so equipped) (P.5-18)
12. Windshield wiper/washer switch (P.2-19)
13. Ignition switch (P.5-8)/Ignition knob (P.3-13)
14. Center ventilator (P.4-16)
15. Display, Climate and Audio control switches/buttons (P.4-2)/Navigation system*
16. Front passenger supplemental air bag (P.1-19)
17. Snow mode switch (P.2-27)
18. Hood release handle (P.3-25)
19. Fuse box (P.8-23)
20. VDC OFF switch (P.2-28)
21. Parking brake pedal/parking brake release pedal (P.5-15)
22. Tilting/telescopic steering wheel switch (if so equipped) (P.3-29)
23. Tilting steering wheel lock lever (if so equipped) (P.3-29)
24. Telescopic steering wheel lock lever (P.3-29)
25. Hazard warning flasher switch (P.2-25)
26. Heated seat switch (if so equipped) (P.2-26)
27. Cassette player (P.4-26)
28. Cigarette lighter and ashtray (P.2-30)

2-2 Instruments and controls

SIC2134

METERS AND GAUGES

- 29. Automatic transmission selector lever (P.5-12)
- 30. Clock (P.2-28)
- 31. Glove box (P.2-32)

See the page indicated in parentheses for operating details.

*: Refer to the separate Navigation System Owner's Manual. (if so equipped)

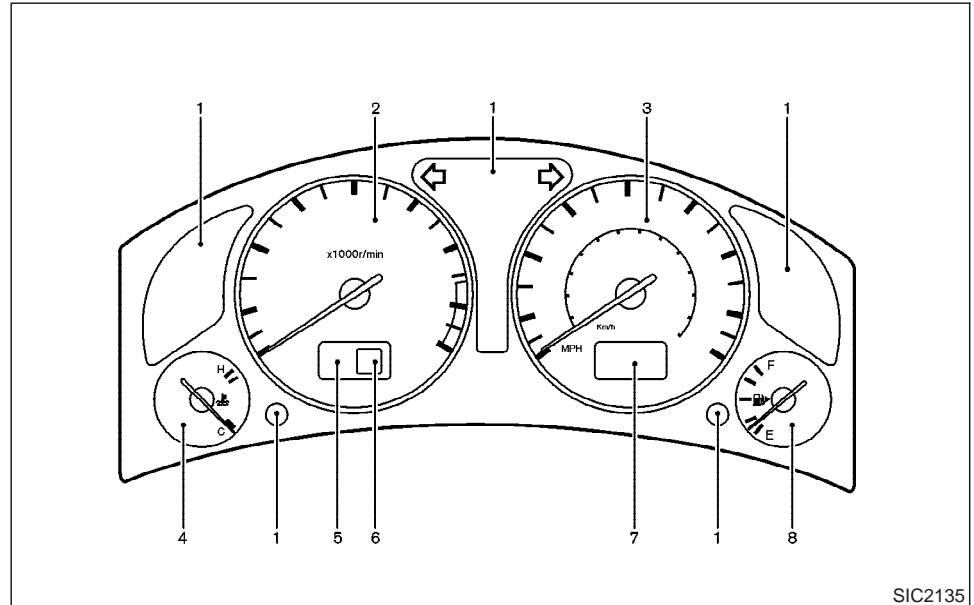

SIC2135

- 1. Warning/Indicator lights
- 2. Tachometer
- 3. Speedometer
- 4. Engine coolant temperature gauge
- 5. Intelligent cruise control system display (if so equipped)
- 6. Automatic transmission position indicator
- 7. Odometer (Total/Twin trip)
- 8. Fuel gauge

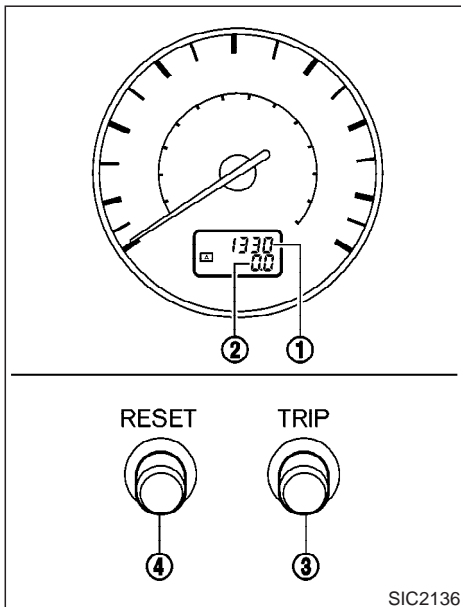

SPEEDOMETER AND ODOMETER

Speedometer

The speedometer indicates vehicle speed (MPH and km/h).

2-4 Instruments and controls

Odometer/Twin trip odometer

The odometer/twin trip odometer are displayed when the ignition key is in the ON position.

The odometer ① records the total distance the vehicle has been driven.

The twin trip odometer ② records the distance of individual trips.

Changing the display:

Pushing the trip knob ③ changes the display as follows:

TRIP A → TRIP B → TRIP A

Resetting the trip odometer:

Pushing the reset knob ④ resets the trip odometer to zero.

Elapsed time, driving distance and average speed information is also available, refer to "trip computer information" in the "Monitor, climate, audio and voice-activated control systems" section later in this manual.

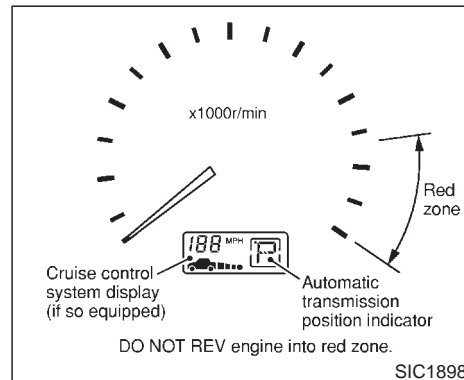

TACHOMETER

The tachometer indicates engine speed in revolutions per minute (r/min).



CAUTION

When engine speed approaches the red zone, shift to a higher gear. Operating the engine in the red zone may cause serious engine damage.

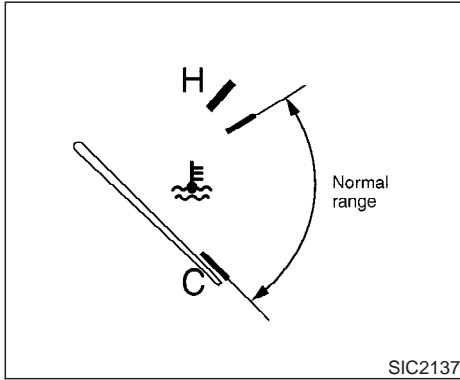

ENGINE COOLANT TEMPERATURE GAUGE

The gauge indicates the engine coolant temperature.

The engine coolant temperature will vary with the outside air temperature and driving conditions.

CAUTION

If the gauge indicates engine coolant temperature over the normal range, stop the vehicle as soon as safely possible. If the engine is overheated, continued operation of the vehicle may seriously damage the engine. See “If your vehicle overheats” in the “6. In case of emergency” section for immediate action required.

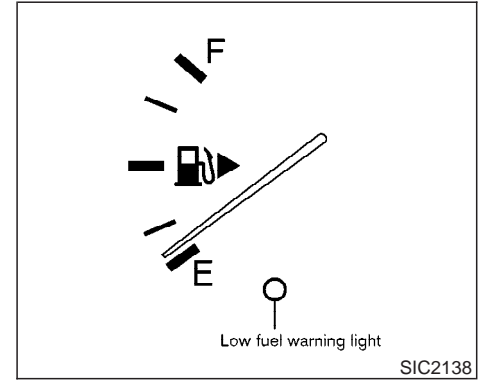

FUEL GAUGE

The gauge indicates the approximate fuel level in the tank.

The gauge may move slightly during braking, turning, acceleration, or going up or down hill.

The gauge needle is designed to move to the E (Empty) position when the ignition switch is turned to the OFF position.

Refill the fuel tank before the gauge registers Empty.

The low fuel warning light comes on when the fuel tank is getting low. Refuel as soon as it is convenient, preferably before the gauge reaches E. There will be a small reserve of fuel in the tank when the fuel gauge needle reaches E.

The  indicates that the fuel filler lid is located on the passenger's side of the vehicle.



CAUTION

- If the vehicle runs out of fuel, the **malfunction indicator lamp (MIL)** may come on. Refuel as soon as possible. After a few driving trips, the **malfunction indicator lamp (MIL)** should turn off. If the lamp remains on after a few driving trips, have the vehicle inspected by an INFINITI dealer.
- For additional information, see the “Malfunction indicator lamp (MIL)” later in this section.

COMPASS DISPLAY

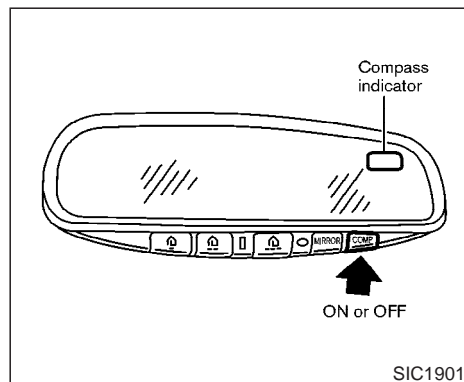

calibrated once it has tracked 3 complete circles.

When the COMPASS switch is in the ON position, the compass display will indicate the direction where the vehicle is heading.

- N: north
- E: east
- S: south
- W: west

If the display reads “C”, calibrate the compass by driving the vehicle in 3 complete circles at less than five mph (8 km/h). You can also calibrate the compass by driving your vehicle on your everyday route. The compass will be

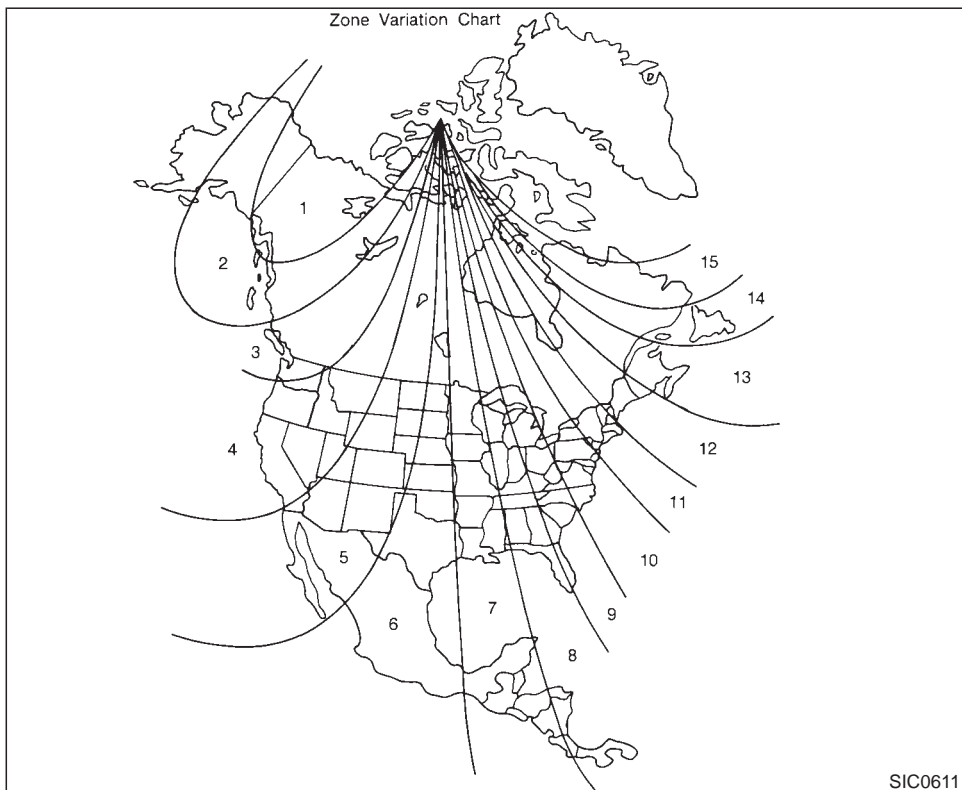

Zone variation change procedure

The difference between magnetic north and geographical north is known as variance. In some areas, this difference can sometimes be great enough to cause false compass readings. Follow these instructions to set the variance for your particular location if this happens:

1. Press the COMPASS switch for more than 3 seconds. The current zone number will appear in the display.
2. Find your current location and variance one number on the zone map.
3. Press the COMPASS switch until the new zone number appears in the display. After you stop pressing the switch in, the display will show a compass direction within a few seconds.

Inaccurate compass direction:

1. With the display turned on, push the COMPASS switch for 3 seconds, until the zone selection comes up (a number will be displayed in the mirror compass window).
2. Toggle until correct zone is found and release switch.
3. The display will show all segments, and return to the normal compass mode within

10 seconds of no switch activity.

4. If the vehicle changes zone, repeat steps 1 thru 3. See map.
 - If the compass deviates from the correct indication soon after repeated adjustment, have the compass checked at an INFINITI dealer.
 - The compass may not indicate the correct compass point in tunnels or while driving up or down a steep hill.
(The compass returns to the correct compass point when the vehicle moves to an area where the geomagnetism is stabilized.)























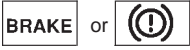





CAUTION

- **Do not install a ski rack, antenna, etc. which are attached to the vehicle by means of a magnet. They affect the operation of the compass.**
- **When cleaning the mirror, use a paper towel or similar material dampened with glass cleaner. Do not spray glass cleaner directly on the mirror as it may cause the liquid cleaner to**







enter the mirror housing.

WARNING/INDICATOR LIGHTS AND AUDIBLE REMINDERS





 ABS or 	Anti-lock brake warning light		Intelligent Cruise Control system warning light (Orange; if so equipped)		High beam indicator light (Blue)
	Automatic transmission check warning light		Low tire pressure warning light (if so equipped)		Intelligent Cruise Control system ON/OFF switch indicator light (Green; if so equipped)
	AWD (All wheel drive) warning light (AWD models)		Low washer fluid warning light		Intelligent Cruise Control system set switch indicator light (if so equipped)
	Preview Function warning light (Orange; if so equipped)		Seat belt warning light		Malfunction indicator lamp (MIL)
	Brake warning light		Supplemental air bag warning light		Slip indicator light
	Charge warning light		Intelligent Key warning light (if so equipped)		Snow mode indicator light
	Door open warning light		Automatic transmission position indicator light		Turn signal/hazard indicator lights
	Engine oil pressure warning light		Cruise main switch indicator light (Green)		Vehicle dynamic control off indicator light
	P position selecting warning light and chime (if so equipped)		Cruise set switch indicator light		

CHECKING BULBS

Apply the parking brake and turn the ignition switch to ON without starting the engine. The following lights will come on:

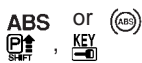
 , BRAKE OR  ,  ,  , **AWD** ,  , 

The following lights come on briefly and then go off:

 ,  ,  ,  ,  ,

If any light fails to come on, it may indicate a burned-out bulb or an open circuit in the electrical system. Have the system repaired promptly.

WARNING LIGHTS

 or  Anti-lock brake warning light

If the light comes on while the engine is running, it may indicate the anti-lock brake system is not functioning properly. Have the system checked by your INFINITI dealer.

If an abnormality occurs in the system, the anti-lock function will cease but the ordinary brakes will continue to operate normally.

If the light comes on while you are driving, contact your INFINITI dealer for repair.

**AT
CHECK**

Automatic transmission check warning light

When the ignition switch is turned ON, the light comes on for 2 seconds. If the light blinks for approximately 8 seconds, it may indicate the automatic transmission system is not functioning properly. Have your INFINITI dealer check and repair the transmission.

AWD

AWD (All wheel drive) warning light (AWD models)

The **AWD** warning light comes on when the ignition switch is turned to ON. It turns off soon after the engine is started.

If the AWD system malfunctions or the revolution, or radius of the front and the rear wheel are different, the warning light will either remain illuminated or blink. See "Using all wheel drive (AWD)" in the "5. Starting and driving" section.



CAUTION

- If the warning light comes on while driving there may be a malfunction in the AWD system even if the driving mode is in the AUTO or LOCK position. Reduce the vehicle speed and have your vehicle checked by an INFINITI dealer as soon as possible.
- Do not drive on dry hard surface roads in the LOCK mode.
- If the AWD warning light blinks on when you are driving:
 - blinks rapidly (about twice a second):
Pull off the road in a safe area, and idle the engine. The driving mode will change to 2WD to prevent the AWD system from malfunctioning. If the warning light turns off, you can drive again.
 - blinks slowly (about once every 2 seconds):
Pull off the road in a safe area, and

idle the engine. Check that all tire sizes are the same, tire pressure is correct and tires are not worn.

If the warning light is still on after the above operation, have your vehicle checked by an INFINITI dealer as soon as possible.

CRUISE

Preview Function warning light (Orange: if so equipped)

The light comes on if there is a malfunction in the Brake Assist (with Preview Function) system.

BRAKE



or Brake warning light

This light functions for both the parking brake and the foot brake systems.

Parking brake indicator:

When the ignition switch is in the ON position, the light comes on when the parking brake is applied.

Low brake fluid warning light:

The light warns of a low brake fluid level. If the light comes on while the engine is running with the parking brake not applied, stop the vehicle

and perform the following:

1. Check the brake fluid level. Add brake fluid as necessary. See “Brake fluid” in the “8. Maintenance and do-it-yourself” section.



WARNING

- **Your brake system may not be working properly if the warning light is on. Driving could be dangerous. If you judge it to be safe, drive carefully to the nearest service station for repairs. Otherwise, have your vehicle towed because driving it could be dangerous.**
- **Pressing the brake pedal with the engine stopped and/or low brake fluid level may increase your stopping distance and braking will require greater pedal effort as well as greater pedal travel.**
- **If the brake fluid level is below the MIN mark on the brake fluid reservoir, do not drive until the brake system has been checked at an INFINITI dealer.**

2. If the brake fluid level is correct, have the warning system checked by an INFINITI dealer.



Charge warning light

If the light comes on while the engine is running, it may indicate that the charging system is not functioning properly. Turn the engine off and check the alternator belt. If the belt is loose, broken, missing or if the light remains on, see your INFINITI dealer immediately.



CAUTION

Do not continue driving if the belt is loose, broken or missing.



Door open warning light

This light comes on when any of the doors are not closed securely while the ignition switch is ON.



Engine oil pressure warning light

This light warns of low engine oil pressure. If the light flickers or comes on during normal driving, pull off the road in a safe area, stop the engine **immediately** and call an INFINITI dealer or other authorized repair shop.

The engine oil pressure warning light is not designed to indicate a low oil level. Use the dipstick to check the oil level. See “Engine oil” in the “8. Maintenance and do-it-yourself” section.



CAUTION

Running the engine with the engine oil pressure warning light on could cause serious damage to the engine almost immediately. Turn off the engine as soon as it is safe to do so.



P position selecting warning light and chime (for Intelligent Key system) (if so equipped)

The light blinks in red and warning buzzer beeps when the selector lever is not in the P position and you are out with the Intelligent Key.

When the warning light blinks, move the selector lever to P position and return the ignition knob to the LOCK position.

CRUISE Intelligent Cruise Control system warning light (Orange; if so equipped)

The light comes on if there is a malfunction in the Intelligent Cruise Control system.

 Low tire pressure warning light (if so equipped)

After the ignition switch is turned ON, this light comes on for about 1 second and turns off.

This light warns of low tire pressure.

INFINITI's low tire pressure warning system is a tire pressure monitoring system. It monitors tire pressure of all tires except the spare. When the tire pressure monitoring system warning light is lit, one or more of your tires is significantly under-inflated. You should stop and check your tires as soon as possible, and inflate them to the proper pressure as indicated on the vehicle's tire information placard. Driving on a significantly under-inflated tire causes the tire to overheat and can lead to tire failure.

Under-inflation also reduces fuel efficiency and tire tread life, and may affect the vehicle's handling and stopping ability. Each tire, including the spare, should be checked monthly when cold and set to the recommended infla-

tion pressure as specified in the vehicle placard and Owner's Manual.

The recommended inflation pressure may also be found on the Tire and Loading Information label.

Low tire pressure warning:

If the vehicle is being driven with low tire pressure (lower than 26 psi, 180 kPa), the light will illuminate and the chime will sound for about 10 seconds. If you select the tire pressure information in the display, the FLAT TIRE warning message will be displayed.

For additional information, see "Low tire pressure warning system" in the "5. Starting and driving" section and "Flat tire" in the "6. In case of emergency" section.

Also, you can check the pressure of all 4 tires on the display screen. See "Tire pressure information" in the "4. Display screen, heater, air conditioner and audio systems" section.



WARNING

- If the light does not come on with the key switch turned ON, have the vehicle checked by an INFINITI dealer

as soon as possible.

- If the light comes on while driving, avoid sudden steering maneuvers or abrupt braking, reduce vehicle speed, pull off the road to a safe location and stop the vehicle as soon as possible. Serious vehicle damage could occur and may lead to an accident and could result in serious personal injury. Check the tire pressure for all four tires. Adjust the tire pressure to the recommended COLD tire pressure shown on the Tire and Loading Information label to turn the low tire pressure warning light OFF. If the light still comes on while driving after adjusting the tire pressure, a tire may be flat. If you have a flat tire, replace it with a spare tire as soon as possible.
- When a spare tire is mounted or a wheel is replaced, tire pressure will not be indicated and the low tire pressure warning system will not function. Contact your INFINITI dealer as soon as possible for tire replacement and/or system resetting.



CAUTION

- **The low tire pressure warning is not a substitute for the regular tire pressure check. Be sure to check the tire pressure regularly.**
- **If the vehicle is being driven at speeds of less than 20 MPH (32 km/h), the low tire pressure warning system may not operate correctly.**
- **Be sure to install the specified size of tires to the four wheels correctly.**



Low washer fluid warning light

This light comes on when the washer tank fluid is at a low level. Add washer fluid as necessary. See “Window washer fluid” in the “8. Maintenance and do-it-yourself” section.



Seat belt warning light and chime

The light and chime remind you to fasten seat belts. The light illuminates whenever the ignition switch is turned to ON, and will remain

illuminated until the driver’s seat belt is fastened. At the same time, the chime will sound for about 6 seconds unless the driver’s seat belt is securely fastened.

See “Seat belts” in the “1. Seats, restraints and supplemental air bag systems” section for precautions on seat belt usage.



Supplemental air bag warning light

After turning the ignition switch to the ON position, the supplemental air bag warning light will illuminate. The supplemental air bag warning light will turn off after about 7 seconds if the system is operational.

If any of the following conditions occur, the supplemental front air bag, supplemental side air bag and curtain side-impact air bag systems, and pre-tensioner seat belt need servicing and your vehicle must be taken to your nearest authorized INFINITI dealer.

- The supplemental air bag warning light remains on after approximately 7 seconds.
- The supplemental air bag warning light flashes intermittently.
- The supplemental air bag warning light does not come on at all.

Unless checked and repaired, the Supplemental Restraint Systems and/or the pre-tensioner seat belt may not function properly. For additional information, see “Supplemental restraint system” in the “1. Seats, restraints and supplemental air bag systems” section.



WARNING

If the supplemental air bag warning light is on, it could mean that the supplemental front air bag, supplemental side air bag and curtain side-impact air bag systems and/or pre-tensioner seat belt system will not operate in an accident. To help avoid injury to yourself or others, have your vehicle checked by an INFINITI dealer as soon as possible.



Intelligent Key warning light (for Intelligent Key system) (if so equipped)

This light comes on in green when it is possible to turn the ignition knob.

When the light comes on in red, it is not possible to turn the knob.

- The warning light blinks in red when the

Intelligent Key is outside the vehicle with the ignition knob in the ACC or ON position. Confirm the location of the key as soon as possible when the warning light blinks in red.

Be sure to carry the Intelligent Key with you while driving the vehicle.

- The warning light goes off about 10 seconds after the Intelligent Key is brought inside the vehicle.

INDICATOR LIGHTS

Automatic transmission position indicator light

When the ignition switch is turned to the ON position, the indicator in the tachometer shows the automatic transmission selector lever position. See "Driving with automatic transmission" in the "5. Starting and driving" section.

Cruise main switch indicator light (Green)

The light comes on when the cruise control main switch is pushed. The light goes out when the main switch is pushed again. When the cruise main switch indicator light comes on, the cruise control system is operational.

Cruise set switch indicator light

The light comes on while the vehicle speed is controlled by the cruise control system. If the light blinks while the engine is running, it may indicate the cruise control system is not functioning properly. Have the system checked by your INFINITI dealer.

High beam indicator light (Blue)

This light comes on when the headlight high beam is on and goes out when the low beam is selected.

Intelligent Cruise Control system ON/OFF switch indicator light (Green; if so equipped)

The light comes on when the ICC system ON/OFF switch is pushed. The light goes out when the ON/OFF switch is pushed again. While the ON/OFF switch indicator light comes on, the ICC system is operational.

Intelligent Cruise Control system set switch indicator light (if so equipped)

The light comes on while the vehicle speed is controlled by the Intelligent Cruise Control system. If the light blinks while the engine is running, it may indicate the Intelligent Cruise Control system is not functioning properly. Have the system checked by your INFINITI dealer.

Malfunction indicator lamp (MIL)

If the malfunction indicator lamp comes on steady or blinks while the engine is running, it may indicate a potential emission control malfunction.

The malfunction indicator lamp may also come on steady if the fuel filler cap is loose or missing, or if the vehicle runs out of fuel. Check to make sure the fuel filler cap is installed and closed tightly, and that the vehicle has at least three gallons of fuel in the fuel tank.

After a few driving trips, the  lamp should turn off if no other potential emission control system malfunction exists.

Operation

The malfunction indicator lamp will come on in one of two ways:

- Malfunction indicator lamp on steady — An emission control system malfunction has been detected. Check the fuel filler cap. If the fuel filler cap is loose or missing, tighten or install the cap and continue to drive the vehicle. The **ENGINE SERVICE SOON** lamp should turn off after a few driving trips. If the **ENGINE SERVICE SOON** lamp does not turn off after a few driving trips, have the vehicle inspected by an INFINITI dealer. You do not need to have your vehicle towed to the dealer.
- Malfunction indicator lamp blinking — An engine misfire has been detected which may damage the emission control system. To reduce or avoid emission control system damage:
 - a) Do not drive at speeds above 45 MPH (72 km/h).
 - b) Avoid hard acceleration or deceleration.
 - c) Avoid steep uphill grades.
 - d) If possible, reduce the amount of cargo being hauled or towed.

The malfunction indicator lamp may stop blinking and come on steady.

Have the vehicle inspected by an INFINITI

dealer. You do not need to have your vehicle towed to the dealer.



CAUTION

Continued vehicle operation without having the emission control system checked and repaired as necessary could lead to poor driveability, reduced fuel economy, and possible damage to the emission control system.

SLIP Slip indicator light

This indicator will blink when the VDC system or the traction control system is operating, thus alerting the driver to the fact that the road surface is slippery and the vehicle is nearing its traction limits.

SNOW Snow mode switch indicator light

When selecting SNOW mode while the engine is running, this light will illuminate. See “SNOW MODE SWITCH” in the “2. Instruments and controls” section.



Turn signal/hazard indicator lights

The light flashes when the turn signal switch lever or hazard switch is turned on.



Vehicle dynamic control off indicator light

The light comes on when the vehicle dynamic control (VDC) off switch is pushed to OFF. This indicates the VDC system and traction control system are not operating. When the VDC off indicator light and slip indicator light come on with the VDC system turned on, this light alerts the driver to the fact that the VDC system's fail-safe mode is operating, i.e. the VDC system may not be functioning properly. Have the system checked by your INFINITI dealer. If an abnormality occurs in the system, the VDC system function will be canceled but the vehicle is still driveable. For additional information, see “Vehicle dynamic control (VDC) system” in the “5. Starting and driving” section of this manual.

AUDIBLE REMINDERS

Key reminder chime

The chime will sound if the driver's side door is opened while the key is left in the ignition switch (ignition switch is turned off). Remove

SECURITY SYSTEMS

the key and take it with you when leaving the vehicle.

Light reminder chime

The headlights will turn off when the front door is opened with the light switch on unless the ignition switch is in the ON position, or in the case of a model with the Intelligent Key, when the ignition knob is not in the LOCK position.

When you turn the headlight switch ON again after the lights automatically turn off and when you open the driver's door, the lights will not turn off automatically and a chime will sound instead. See the battery saver system under "Headlight switch" in this section for details. Make sure to turn the light switch off when you leave the vehicle.

Brake pad wear warning

The disc brake pads have audible wear warnings. When a brake pad requires replacement, it will make a high pitched scraping sound when the vehicle is in motion whether or not the brake pedal is depressed. Have the brakes checked as soon as possible if the warning sound is heard.

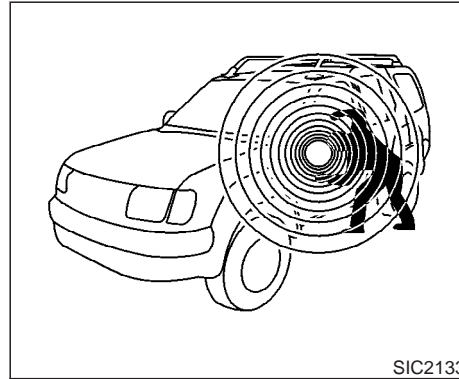

Your vehicle has two types of security systems, as follows:

- Vehicle Security System
- INFINITI Vehicle Immobilizer System

The security condition will be shown by the security indicator light.

VEHICLE SECURITY SYSTEM

The vehicle security system provides visual and audio alarm signals if parts of the vehicle are disturbed.

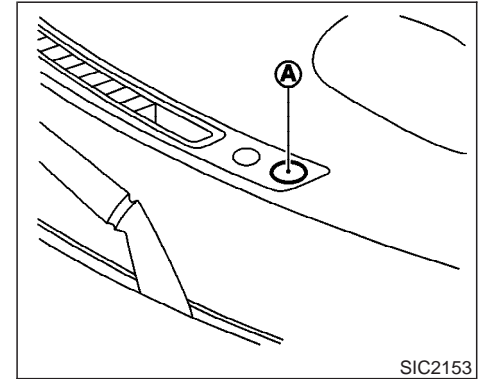

How to activate the vehicle security system

1. Close all windows.

The system can be activated even if the windows are open.

2. Remove the key from the ignition switch.
3. Close and lock all doors and the hood.

Lock all doors by pressing the LOCK button on the keyfob, the Intelligent Key or pressing the front door handle request switch or turning the door key. When using the remote keyless entry, the hazard indicators

will operate as shown in “Remote keyless entry system” in the “3. Pre-driving checks and adjustments” section.

4. Confirm that the SECURITY indicator light (A) comes on. The SECURITY indicator light (A) glows for about 30 seconds and then blinks. The system is now activated. If, during this 30 second time period, the door is unlocked by the key or the remote keyless entry, or the ignition key is turned to ACC or ON, the system will not activate.

- **Even when the driver and/or passengers are in the vehicle, the system will activate with all doors and the hood locked and ignition key off. Turn the ignition key to ACC to turn the system off.**

Vehicle security system operation

The security system will give the following alarm:

- The headlights blink and the horn sounds intermittently.
- The alarm automatically turns off after approximately 1 minute. However, the alarm reactivates if the vehicle is tampered with again. The alarm can be shut off by unlocking a door with the key, or by pressing the UNLOCK button on the electronic ignition key.

The alarm is activated by:

- Opening the door without using the key or remote keyless entry.
- Opening the back door without using the key or remote keyless entry.
- Opening the hood.

How to stop alarm

The alarm will stop only by unlocking a door with the key, or by pressing the UNLOCK button on the keyfob or Intelligent Key. The alarm will not stop if the ignition switch is turned to ACC or ON.

If the system does not operate as described above, have it checked by your INFINITI dealer.

INFINITI VEHICLE IMMOBILIZER SYSTEM

The INFINITI Vehicle Immobilizer System will not allow the engine to start without the use of the registered INFINITI Vehicle Immobilizer System key.

If the engine fails to start using the registered INFINITI Vehicle Immobilizer System key, it may be due to interference caused by another INFINITI Vehicle Immobilizer System key, an automated toll road device or automated pay-

ment device on the key ring. Restart the engine using the following procedures:

1. Leave the ignition switch in the ON position for approximately 5 seconds.
2. Turn the ignition switch to the OFF or LOCK position and wait approximately 10 seconds.
3. Repeat step 1 and 2 again.
4. Restart the engine while holding the device (which may have caused the interference) separate from the registered INFINITI Vehicle Immobilizer System key.

If this procedure allows the engine to start, INFINITI recommends placing the registered INFINITI Vehicle Immobilizer System key on a separate key ring to avoid interference from other devices.

Statement related to section 15 of FCC rules for INFINITI Vehicle Immobilizer System (CONT ASSY-BCM, ANT ASSY-IMMOBILIZER)

This device complies with part 15 of the FCC Rules and RSS-210 of Industry Canada. Operation is subject to the following two conditions;

(1) This device may not cause harmful interference, and (2) this device must ac-

cept any interference received, including interference that may cause undesired operation of the device.

CHANGES OR MODIFICATIONS NOT EXPRESSLY APPROVED BY THE MANUFACTURER RESPONSIBLE FOR COMPLIANCE COULD VOID THE USER'S AUTHORITY TO OPERATE THE EQUIPMENT.

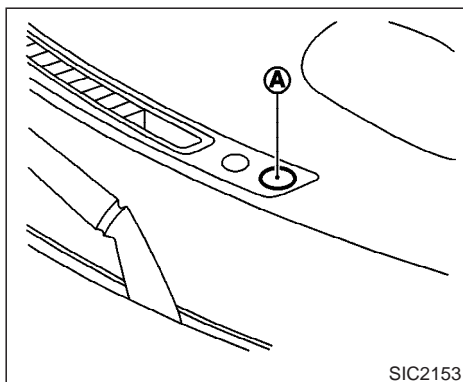

SIC2153

If the light still remains on and/or the engine will not start, see your INFINITI dealer for INFINITI Vehicle Immobilizer System service as soon as possible. Please bring all electronic ignition keys that you have when visiting your INFINITI dealer for service.

Security indicator light **A**

This light **A** blinks whenever the ignition key is removed for 5 seconds after the ignition switch is in the OFF position (mechanical key) or the ignition switch is in the Lock position (intelligent key). This function indicates the security systems equipped on the vehicle are operational.

If a non-registered key is in the ignition switch, the indicator light comes on.

If INFINITI Vehicle Immobilizer System is malfunctioning, this light will remain on while the ignition key is in the ON position.

WINDSHIELD WIPER AND WASHER SWITCH

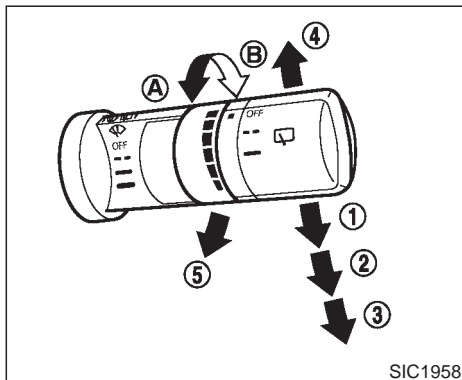

The windshield wiper and washer operates when the ignition switch is in the ON position.

Push the lever down to operate the wiper at the following speed:

- ① Intermittent — intermittent operation can be adjusted by turning the knob toward **A** (Slower) or **B** (Faster). Also, the intermittent operation speed varies in accordance with the vehicle speed. (For example, when the vehicle speed is high, the intermittent operation speed will be faster.)
- ② Low — continuous low speed operation
- ③ High — continuous high speed operation

Push the lever up ④ to have one sweep operation of the wiper.

Pull the lever toward you ⑤ to operate the washer. Then the wiper will also operate several times.



WARNING

In freezing temperatures the washer solution may freeze on the windshield and obscure your vision which may lead to an accident. Warm the windshield with the defroster before you wash the windshield.



CAUTION

The following could damage the washer system:

- Do not operate the washer continuously for more than 30 seconds.
- Do not operate the washer if the reservoir tank is empty.

REAR WINDOW WIPER AND WASHER SWITCH

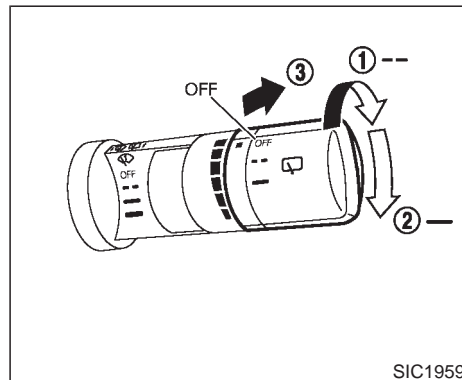

The rear window wiper and washer operate when the ignition switch is in the ON position.

Turn the switch clockwise from the OFF position to operate the wiper.

- ① Intermittent — intermittent operation (not adjustable)
- ② Low — continuous low speed operation

Push the switch forward ③ to operate the washer. Then the wiper will also operate several times.



CAUTION

- If the rear window wiper operation is interrupted by snow etc., the wiper may stop moving to protect its motor. If this occurs, turn the wiper switch to OFF and remove the snow etc. on and around the wiper arms. After about 1 minute, turn the switch ON again to operate the wiper.
- Do not operate the washer continuously for more than 30 seconds.
- Do not operate the washer if reservoir tank is empty.



WARNING

In freezing temperatures the washer solution may freeze on the rear window glass and obscure your vision. Warm the rear window glass with the defroster before you wash.

REAR WINDOW AND OUTSIDE MIRROR DEFROSTER SWITCH

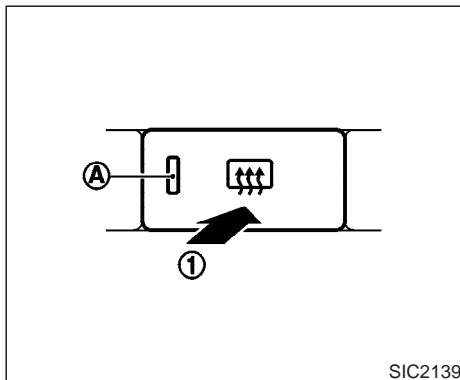

To defog/defrost the rear window glass and outside mirrors, start the engine and push the switch on ①. The indicator light (A) will come on. Push the switch again to turn the defroster off.

It will automatically turn off in approximately 15 minutes.



CAUTION

When cleaning the inner side of the rear window, be careful not to scratch or damage the rear window defroster.

HEADLIGHT AND TURN SIGNAL SWITCH

XENON HEADLIGHTS



WARNING



HIGH VOLTAGE

- When xenon headlights are on, they produce a high voltage. To prevent an electric shock, never attempt to modify or disassemble. Always have your xenon headlights replaced at an INFINITI dealer.
- Xenon headlights provide considerably more light than conventional headlights. If they are not correctly aimed, they might temporarily blind an oncoming driver or the driver ahead of you and cause a serious accident. If headlights are not aimed correctly, immediately take your vehicle to an INFINITI dealer and have the headlights adjusted correctly.

When the xenon headlight is initially turned on, its brightness or color varies slightly. However, the color and brightness will soon stabilize.

- The life of xenon headlights will be shortened by frequent on-off operation. It is generally desirable not to turn off the headlights for short intervals (for example, when the vehicle stops at a traffic signal). Even when the daytime running lights are active (Canada only), the xenon headlights do not turn on. This way the life of the xenon headlights is not reduced.
- If the xenon headlight bulb is close to burning out, the brightness will drastically decrease, the light will start blinking, or the color of the light will become reddish. If one or more of the above signs appear, contact an INFINITI dealer.

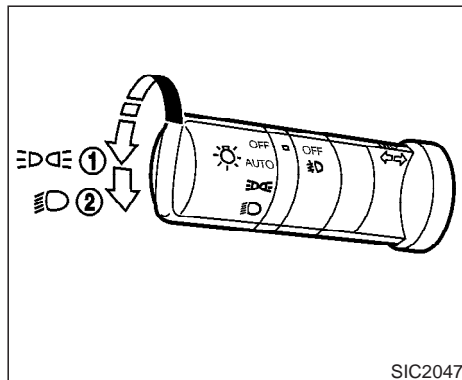

Type A

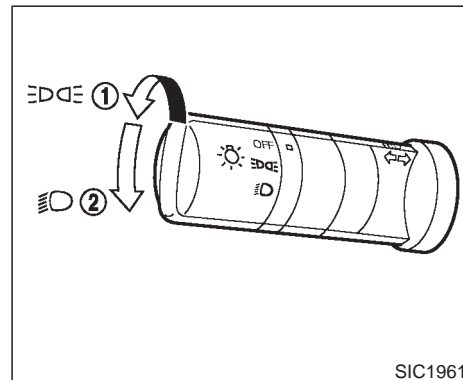

Type B

HEADLIGHT SWITCH

Lighting

- ① Turn the switch to the **EDGE** position:
The front park, side marker, tail, license plate and instrument lights will come on.
- ② Turn the switch to the **D** position:
Headlights will come on and all the other lights remain on.

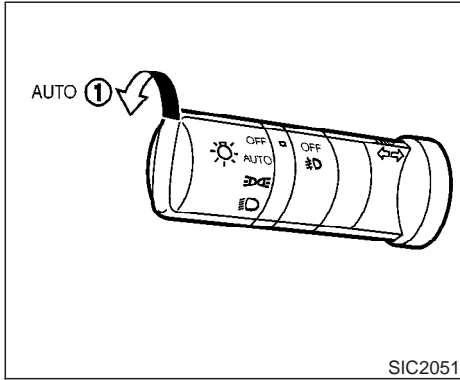

The autolight system can turn on the headlights automatically when it is dark, turn off the headlights when it is light, and keep the headlights on for up to 45 seconds after you turn the switch to OFF and open any door then close all the doors.



If the ignition switch is turned OFF and one of the doors is opened and this condition is continued, the headlights remain ON for five minutes.

Autolight system (if so equipped)

The autolight system allows the headlights to be set so they turn on and off automatically.

To set the autolight system:

1. Make sure the headlight switch is in the AUTO position.
2. Turn the ignition switch to ON.
3. The autolight system automatically turns the headlights on and off.

To turn the autolight system off, turn the switch to the OFF, , or  position.

2-22 Instruments and controls

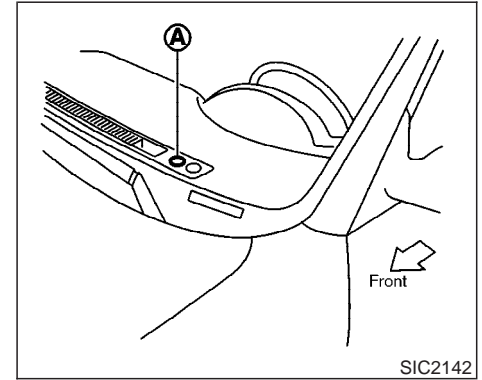

Be sure not to put anything on top of the photo sensor  located on the top left-hand side of the instrument panel. The photo sensor controls the autolamp; if it is covered, the photo sensor reacts as if it is dark and the headlights will illuminate.

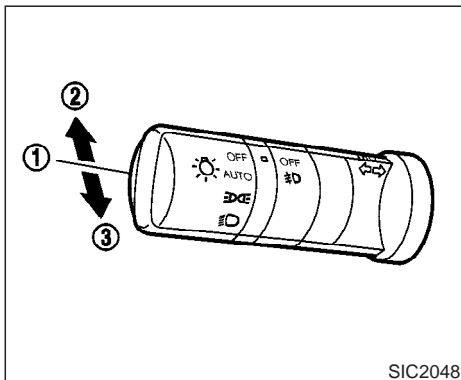

Headlight beam select

- ① To select the low beam, put the lever in the neutral position as shown.
- ② To select the high beam, push the lever forward. Pull it back to select the low beam.
- ③ Pulling the lever toward you will flash the headlight high beam.

Battery saver system

- When the headlight switch is in the OFF or D position while the ignition switch is in the ON position, the lights will automatically turn off 5 minutes after the ignition switch has been turned to the OFF position.
- When the headlight switch remains in the OFF or D position after the lights automatically turn off, the lights will turn on for 5 minutes when the headlight switch is turned to the OFF position and then turn to the OFF or D position.



CAUTION

- **Be sure to turn the light switch to the OFF position when you leave the vehicle for extended periods of time, otherwise the battery will go dead.**
- **Never leave the light switch on when the engine is not running for extended periods of time even if the headlights turn off automatically.**

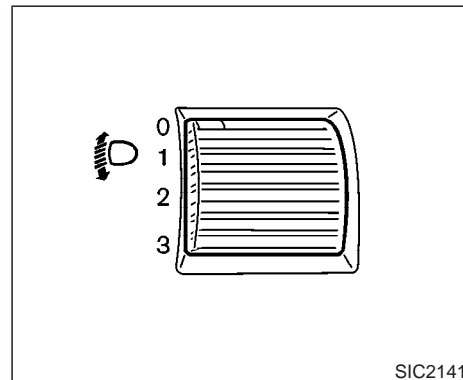

Headlight aiming control (if so equipped)

Depending on the number of occupants in the vehicle and the load it is carrying, the headlight axis may be higher than desired. If the vehicle is traveling on a hilly road, the headlights may directly hit the rearview mirror of the vehicle ahead or the windshield of the oncoming vehicle. The light axis can be lowered with the operation of the switch.

The larger the number designated on the switch, the lower the axis.

When traveling with no heavy load or on a flat road, select position 0.



WARNING

Xenon headlights are extremely bright compared to conventional headlights. If the xenon headlights hit the rearview mirror of the vehicle ahead or the windshield of the oncoming vehicle, the driver of these vehicles may have difficulty driving because of the brightness. Use the headlight aiming control switch to lower the light axis. See earlier in this section for information on xenon headlights.

DAYTIME RUNNING LIGHT SYSTEM (CANADA ONLY)

The daytime running lights automatically illuminate when the engine is started with the parking brake released. The daytime running lights operate with the headlight switch in the OFF position or in the $\equiv \square \equiv$ position.

If the parking brake is applied before the engine is started, the daytime running lights do not illuminate. The daytime running lights illu-

minate once the parking brake is released. The daytime running lights will remain on until the ignition switch is turned off.

The daytime running light may come on after turning the key to the OFF position and immediately turning it to the ON position. This is not a malfunction.

The daytime running light will be turned off when the headlight switch is turned to the AUTO or $\equiv \square \equiv$ position.

The daytime running light will remain on until the ignition switch is turned to the ACC or OFF position.

Turn the fog light switch to the $\equiv \square \equiv$ position to turn the fog light ON when driving at night if necessary.



WARNING

When the daytime running light system is active, tail lights on your vehicle are not on. It is necessary at dusk to turn on your headlights. Failure to do so could cause an accident injuring yourself and others.

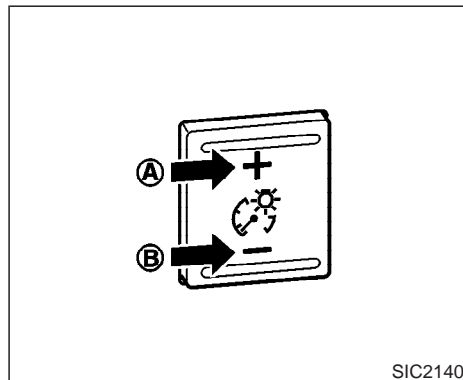

INSTRUMENT BRIGHTNESS CONTROL

The instrument brightness control operates when the light switch is in the $\equiv \square \equiv$ or $\equiv \square \equiv$ position.

To adjust the brightness of instrument panel lights, press the control switches located on the left side of the meter panel. Pressing the upper switch (A) will brighten the lights. The lower switch (B) dims the lights. Repeatedly pressing the lower switch will turn the lights off.

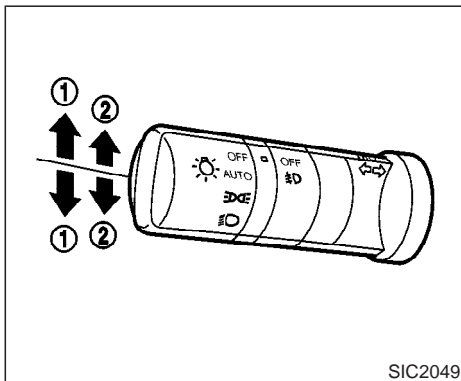

TURN SIGNAL SWITCH

① Turn signal

Move the lever up or down to signal the turning direction. When the turn is completed, the turn signals cancel automatically.

② Lane change signal

To indicate a lane change, move the lever up or down to the point where lights begin flashing.

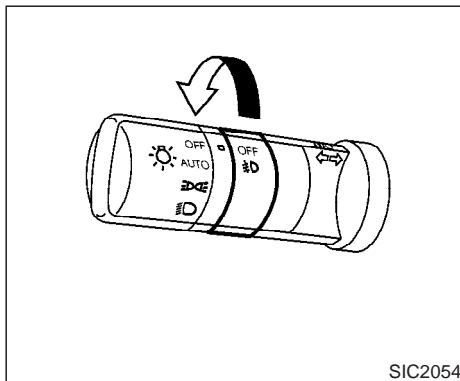

FOG LIGHT SWITCH (if so equipped)

To turn the fog lights on, turn the headlight switch to the ☀️ position, then turn the switch to the ☁️ position. To turn them off, turn the switch to the OFF position.

The headlights must be on and the low beams selected for the fog lights to operate. The fog lights automatically turn off when the high beam headlights are selected.

HAZARD WARNING FLASHER SWITCH

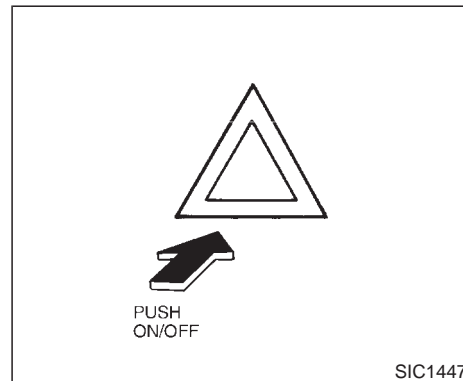

Push the switch on to warn other drivers when you must stop or park under emergency conditions. All turn signal lights will flash.

Some state laws may prohibit the use of the hazard warning flasher switch while driving.



WARNING

- If stopping for an emergency, be sure to move the vehicle well off the road.

- Do not use the hazard warning flashers while moving on the highway unless unusual circumstances force you to drive so slowly that your vehicle might become a hazard to other traffic.
- Turn signals do not work when the hazard warning flasher lights are on.

The flasher can be actuated with the ignition switch either off or on.

HORN

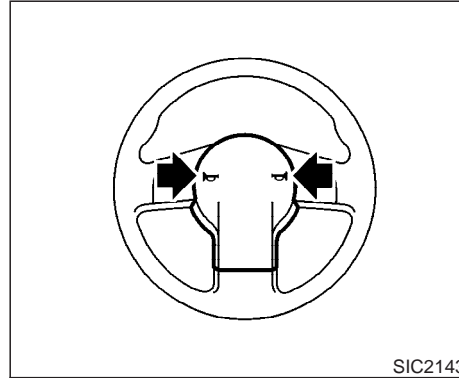

To sound the horn, push around the horn marks of the steering wheel.



WARNING

Do not disassemble the horn. Doing so could affect proper operation of the supplemental front air bag system. Tampering with the supplemental front air bag system may result in serious personal injury.

HEATED SEATS (if so equipped)

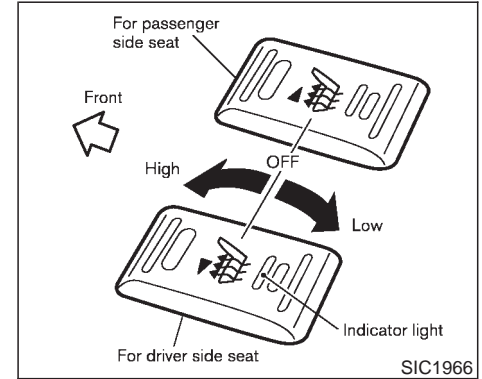

The front seats are warmed by built-in heaters. The switches located on the center console can be operated independently of each other.

1. Start the engine.
2. Select heat range.
 - For low heat, press the (Low) side of the switch.
 - For high heat, press the (High) side of the switch.
 - For no heat, the switch has a center OFF position between low and high.

The indicator light in the switch will illumi-

nate when low or high is selected.

The heater is controlled by a thermostat, automatically turning the heater on and off. The indicator light will remain on as long as the switch is on.

3. When the vehicle's interior is warmed, or before you leave the vehicle, be sure to turn the switch to the off position (center).



CAUTION

- The battery could run down if the seat heater is operated while the engine is not running.
- Do not use the seat heater for extended periods or when no one is using the seat.
- Do not put anything on the seat which insulates heat, such as a blanket, cushion, seat cover, etc. Otherwise, the seat may become overheated.
- Do not place anything hard or heavy on the seat or pierce it with a pin or similar object. This may result in damage to the heater.

- Any liquid spilled on the heated seat should be removed immediately with a dry cloth.
- When cleaning the seat, never use gasoline, thinner, or any similar materials.
- If any abnormalities are found or the heated seat does not operate, turn the switch off and have the system checked by your INFINITI dealer.

SNOW MODE SWITCH

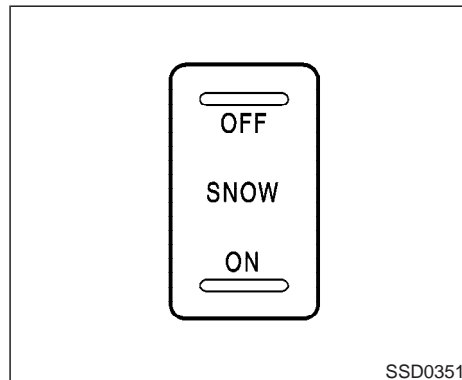

For driving or starting the vehicle on snowy roads or slippery areas, turn on the SNOW mode switch and the SNOW indicator light on the meter panel will illuminate. When the Snow mode is activated, engine output is controlled to avoid wheel spin.

VEHICLE DYNAMIC CONTROL (VDC) OFF SWITCH

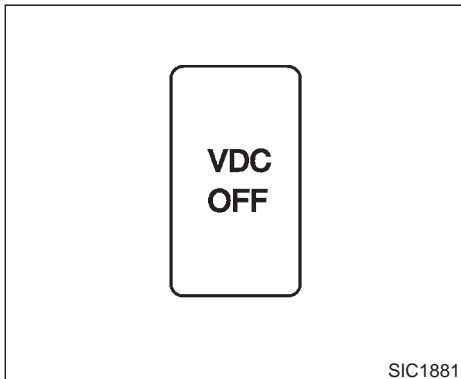

The vehicle should be driven with the Vehicle Dynamic Control (VDC) System on for most driving conditions.

If the vehicle is stuck in mud or snow, the VDC system reduces the engine output to reduce wheel spin. The engine RPM will be reduced even if the accelerator is depressed to the floor. If maximum engine power is needed to free a stuck vehicle, turn the VDC system off.

To cancel the VDC system, push the VDC OFF switch to turn off the system. The **VDC OFF** indicator will come ON.

Push the VDC OFF switch again or restart the

engine to turn ON the system. See "Vehicle dynamic control (VDC) system" in the "5. Starting and driving" section.

CLOCK

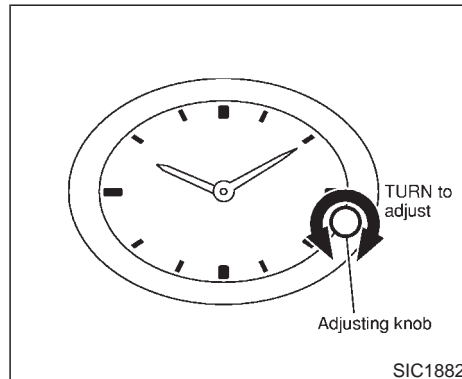

If the power supply is disconnected, the clock will not indicate the correct time. Readjust the time.

ADJUSTING THE TIME

To adjust the time, turn the adjusting knob.

POWER OUTLET



CAUTION

- The outlet and plug may be hot during or immediately after use.
- This power outlet is not designed for use with a cigarette lighter unit.
- Do not use with accessories that exceed a 12 volt, 120W (10A) power draw. Do not use double adapters or more than one electrical accessory.
- Use power outlets with the engine running to avoid discharging the vehicle battery.
- Avoid using power outlets when the air conditioner, climate controlled seat, headlights or rear window defroster is on.
- Before inserting or disconnecting a plug, be sure to turn off the power switch of electrical accessory being used or the ACC power of the vehicle.
- Push the plug in as far as it will go. If

good contact is not made, the plug may overheat or the internal temperature fuse may blow.

- When not in use, be sure to close the cap. Do not allow water to contact the socket.

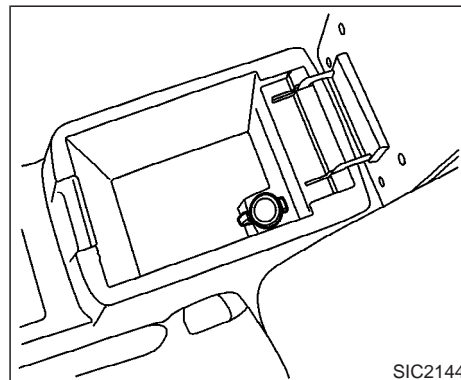

Console

The power outlet is for powering electrical accessories such as cellular telephones.

CIGARETTE LIGHTER AND ASHTRAY

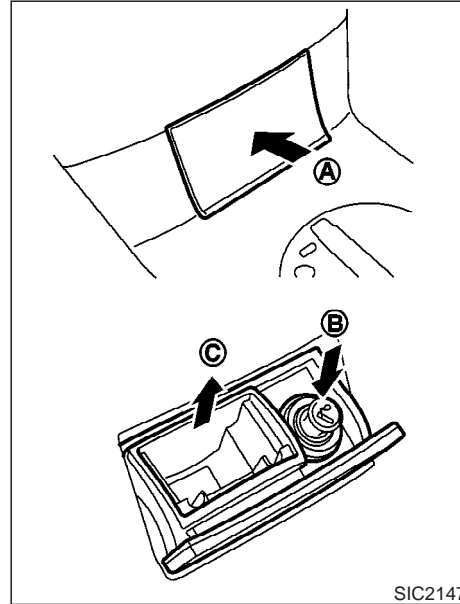
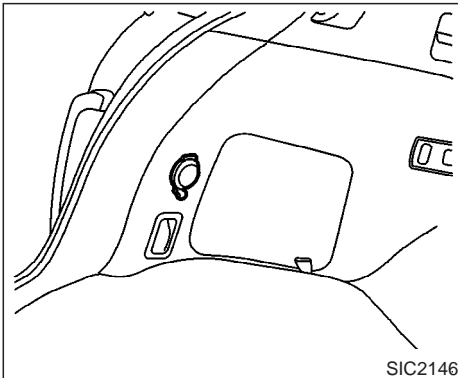
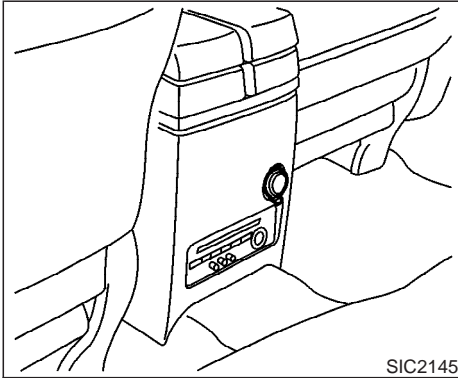

The cigarette lighter operates when the ignition switch is in the ACC or ON position.

Push the lid (A) to open.

Push the lighter (B) in all the way. When the lighter is heated, it will spring out.

Return the lighter to its original position after use.

Pull up the ashtray (C) to remove it.



WARNING

The cigarette lighter should not be used while driving so full attention may be given to vehicle operation.



CAUTION

The cigarette lighter socket is a power source for the cigarette lighter element only. The use of the cigarette lighter socket as a power source for any other accessory is not recommended.

Do not use any other power outlet for an accessory lighter.

STORAGE

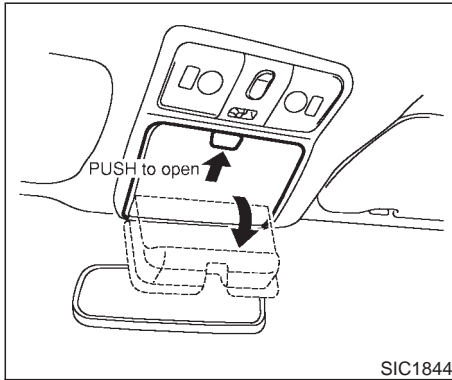

SUNGLASSES HOLDER

The sunglasses holder can be opened by pushing the button.



WARNING

The sunglasses holder should not be used while driving so full attention may be given to vehicle operation.



CAUTION

- Do not use for anything other than glasses.
- Do not leave glasses in the sunglasses holder while parking in direct sunlight. The heat may damage the glasses.

CUP HOLDERS



WARNING

The cup holder should not be used while driving so full attention may be given to vehicle operation.



CAUTION

- Avoid abrupt starting and braking when the cup holder is being used to prevent spilling the drink. If the liquid is hot, it can scald you or your passenger.
- Use only soft cups in the cup holder. Hard objects can injure you in an accident.

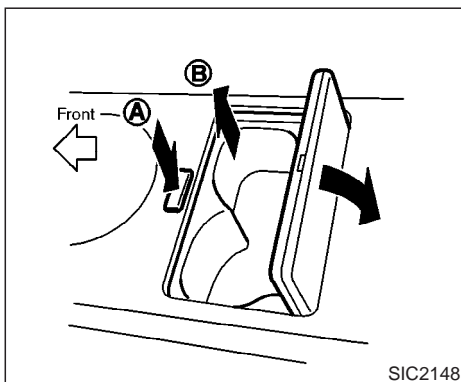

Front cup holder

To open, push (A) the cup holder opener switch.

To close, lower the cup holder lid and push down lightly.

Use the cup holder properly and according to the size of the cups.

To clean the front cup holder, pull up the inside tray (B) and remove it.

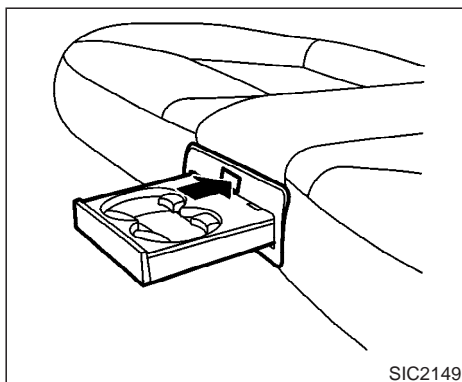

Rear cup holder

Push the cup holder opener switch to draw out the rear cup holder.

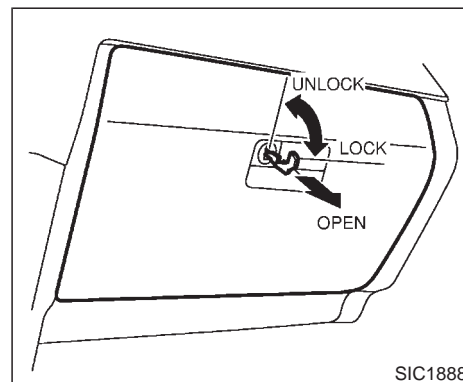

GLOVE BOX

When locking or unlocking the glove box, use the master key, mechanical key or wallet key.

The glove box may be opened by pulling the handle.



WARNING

Keep glove box lid closed while driving to help prevent injury in an accident or a sudden stop.

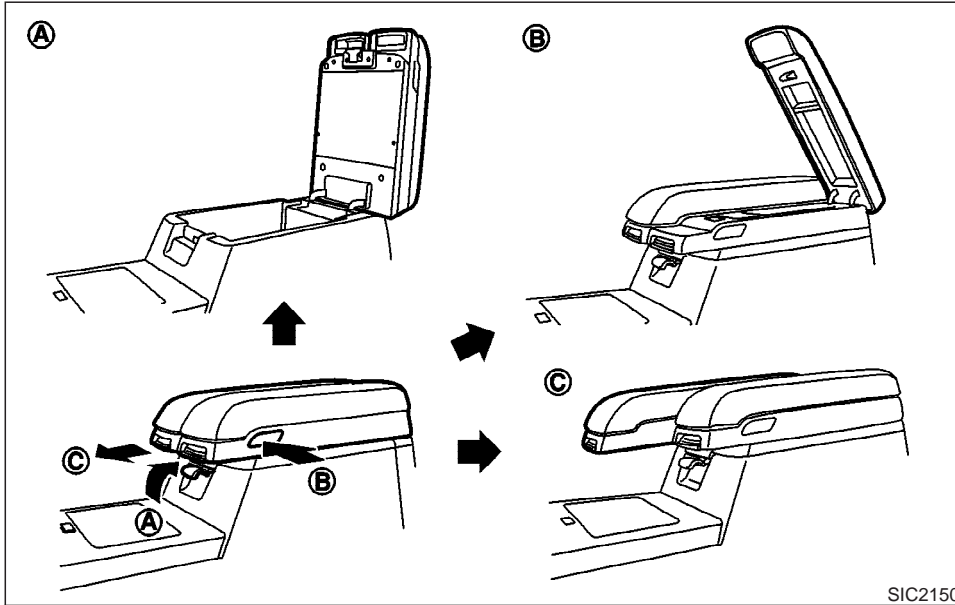

CONSOLE BOX

WARNING

The center console box should not be used while driving so full attention may be given to vehicle operation.

To open the console box, pull up (A).

To use the trays, push (B) and open the covers.

Pull (C) forward, then the lid covers slide to be used as armrests.

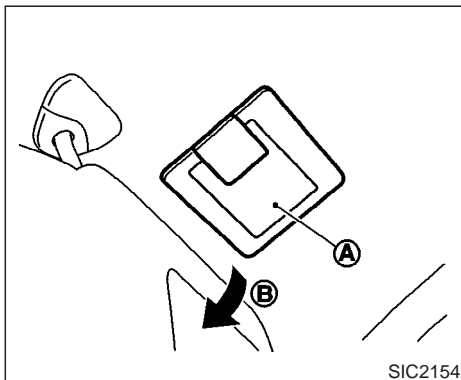

CARD HOLDER

To use the card holder, slide your card (A) in after lowering the sun visor (B).

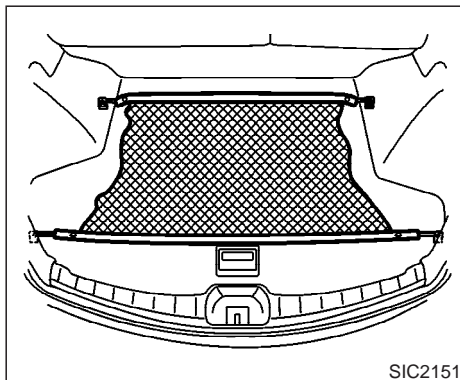

CARGO NET (if so equipped)

The cargo net helps keep packages in the cargo area from moving around while your vehicle is driven.

To install the cargo net, attach the hooks to the retainers.

- Be sure to secure hooks into the retainers. The cargo restrained in the net must not exceed 30 lb (13.6 kg) or the net may not stay secured.



WARNING

- Properly secure all cargo to help prevent it from sliding or shifting.

WINDOWS

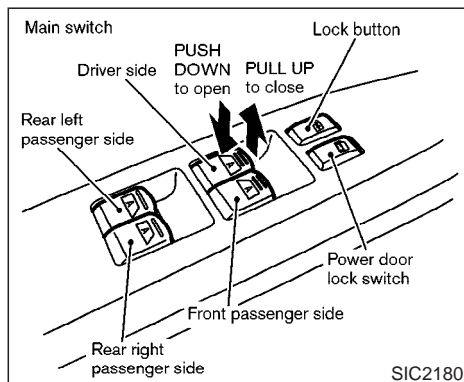

Do not accidentally activate switches or controls and become trapped in a window. Unattended children could become involved in serious accidents.

The power windows operate when the ignition switch is in the ON position and for about 45 seconds, after the ignition switch is turned to the OFF position. If the driver's door or the front passenger's door is opened during this period of about 45 seconds, power to the windows is canceled.

To open or close the window, push down or pull up the switch and hold it. The main switch (driver side switches) will open or close all the windows.

POWER WINDOWS



WARNING

- Make sure that all passengers have their hands, etc. inside the vehicle while it is in motion and before closing the windows. Use the window lock switch to prevent unexpected use of the power windows.
- Do not leave children unattended inside the vehicle. They could unknow-

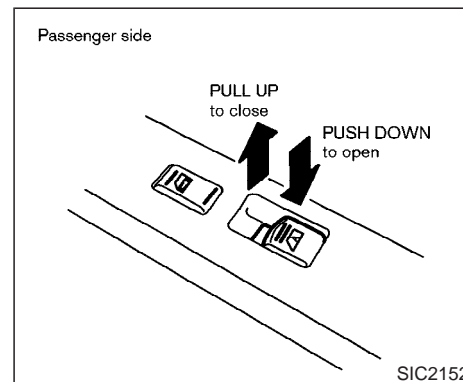

The passenger side switch will open or close only the corresponding window. To open or close the window, hold the switch down or up.

Locking passenger's windows

When the lock button is pushed in, only the driver side window can be opened or closed. Push it in again to cancel.

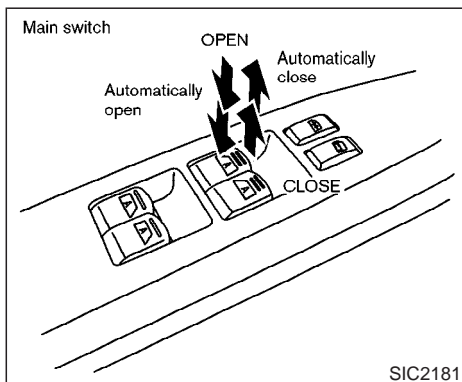

Automatic operation (For front door windows or for all doors' windows)

To fully open or close the window, completely press or lift the switch and release it; it need not be held. The window will automatically open or close all the way. To stop the window, just press or lift the switch on the opposite side.

Auto reverse function (For front door windows or for all doors' windows)

If the control unit detects something caught in a window as it moves up, the window will be immediately lowered.

The auto reverse function can be activated when a window is closed by automatic operation when the ignition switch is in the ON position or for about 45 seconds after the ignition switch is turned to the OFF position.

Depending on the environment or driving conditions, the auto reverse function may be activated if an impact or load similar to something being caught in the window occurs.



WARNING

There are some small distances immediately before the closed position which cannot be detected. Make sure that all passengers have their hands, etc., inside the vehicle before closing the window.

SUNROOF (if so equipped)

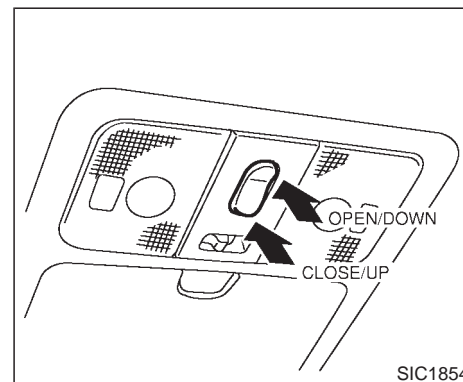

AUTOMATIC SUNROOF

The sunroof will only operate when the ignition switch is in the ON position.

The automatic sunroof is operational for about 45 seconds, even if the ignition switch is turned to the OFF position. If the driver's door or the front passenger's door is opened during this period of about 45 seconds, power to the sunroof is canceled.

Sliding the sunroof

To fully open or close the sunroof, press the switch to the CLOSE or OPEN side for less than 1 second and release it; it need not be

held. The roof will automatically open or close all the way. To stop the roof, press the switch once more while it is opening or closing.

To open or close the sunroof and stop on the way, press the switch to the CLOSE or OPEN side. The roof will stop when releasing the switch.

Tilting the sunroof

To tilt up, first close the sunroof, then press the UP side of the switch and release it; it need not be held. To tilt down the sunroof, press the DOWN side.

Sun shade

Open or close the sun shade by sliding it backward or forward.

The shade will open automatically when the sunroof is opened. However, it must be closed manually.

Auto reverse function (When closing or tilting down the sunroof)

The auto reverse function can be activated when the sunroof is closed or tilted down by automatic operation when the ignition key is in the ON position or for about 45 seconds after the ignition key is turned to the OFF position.

Depending on the environment or driving conditions, the auto reverse function may be activated if an impact or load similar to something being caught in the sunroof occurs.



WARNING

There are some small distances immediately before the closed position which cannot be detected. Make sure that all passengers have their hands, etc., inside the vehicle before closing the sunroof.

When closing:

If the control unit detects something caught in the sunroof as it moves to the front, the sunroof will immediately open backward.

When tilting down:

If the control unit detects something caught in the sunroof as it tilts down, the sunroof will immediately tilt up.



WARNING

- In an accident you could be thrown from the vehicle through an open sunroof. Always use seat belts and child restraints.
- Do not allow anyone to stand up or extend any portion of their body out of the opening while the vehicle is in motion or while the sunroof is closing.



CAUTION

- Remove water drops, snow, ice or sand from the sunroof before opening.
- Do not place any heavy object on the sunroof or surrounding area.

INTERIOR LIGHT

If the sunroof does not close

If the sunroof does not close or open automatically, use the following procedure to return sunroof operation to normal.

1. Press the switch to the CLOSE/UP side to tilt up the sunroof.
2. Press and hold the switch to the CLOSE/UP side for approximately 3 seconds while the sunroof is tilted up.
3. Release the switch once, then press and hold the switch to the CLOSE/UP side again for approximately 10 seconds until the sunroof moves automatically.
4. The sunroof will automatically open and then close all the way.

If you failed at procedure 3. repeat all the procedures from No. 1.

If the sunroof still does not close, have your INFINITI dealer check and repair the sunroof.

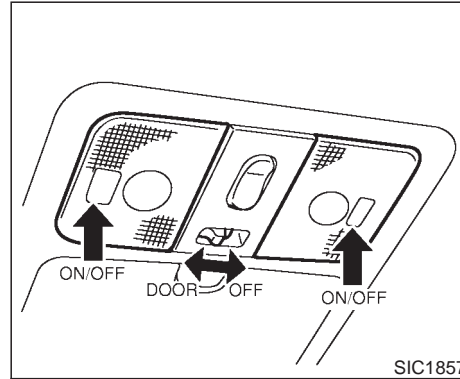

INTERIOR LIGHT

The interior light has a two-position switch.

When the switch is in the door position, the light will illuminate when a door is opened.

The light will stay on for about 30 seconds when:

- The doors are unlocked by the keyfob, a key, the power door lock switch or using the Intelligent Key system while all doors are closed.
- The driver's door is opened and then closed

while the key is removed from the ignition switch.

- The key is removed from the ignition switch while all doors are closed.

The light will turn off while the 30 second timer is activated, when:

- The driver's door is locked either with the keyfob, a key, the power door lock switch or using the Intelligent Key system.
- The ignition switch is turned ON.

MAP LIGHTS

When the switch is pushed in, the light will turn on. When the switch is pushed again, the light will turn off.

When the map light switch is in the ON position, it will automatically turn off 30 minutes after the ignition switch has been turned to the OFF position. To turn on the light again, turn the ignition switch to the ON position.

The map, personal, and vanity mirror lights will automatically turn off 30 minutes after the latest operation of the following with the ignition switch in the ACC or OFF position:

- Opening or closing any door
- Locking or unlocking with the keyfob, a key

or the power door lock switch.

- Inserting or removing a key from the ignition switch

These lights will turn on again when any of the above operations is performed after the lights have turned off automatically. (The lights will turn off 30 minutes after the latest operation of the above as well.)



CAUTION

- Turn off the map, personal and vanity mirror lights when you leave the vehicle.
- Do not use for extended periods of time with the engine stopped. This could result in a discharged battery.

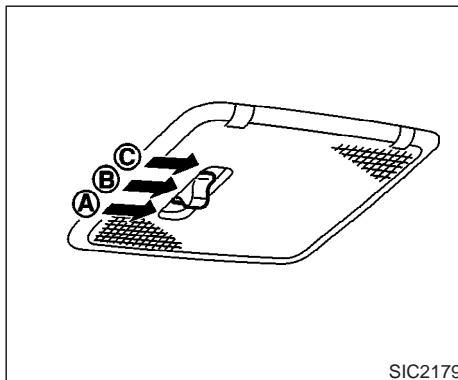

SIC2179

Ceiling light (if so equipped)

The ceiling light has a three-position switch.

When the switch is in the door position (B), the light will illuminate when the door is opened. Same as the door position of the interior light.

When the personal light switch is in the ON position (A), it will automatically turn off 30 minutes after the ignition switch has been turned to the OFF position (C). To turn on the light again, turn the ignition switch to the ON position.

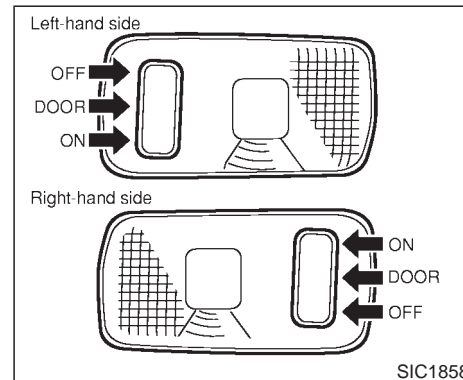

SIC1858

REAR PERSONAL LIGHT

The rear personal light has a three-position switch.

When the switch is in the door position, the light will illuminate when the door is opened.

When the personal light switch is in the ON position, it will automatically turn off 30 minutes after the ignition switch has been turned to the OFF position. To turn on the light again, turn the ignition switch to the ON position.

VANITY MIRROR LIGHT

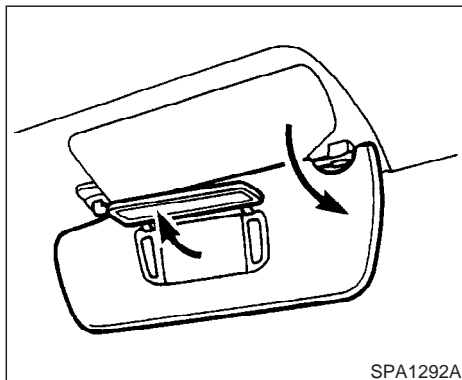

The light on the vanity mirror will turn on when the cover on the vanity mirror is opened.

When the vanity mirror light stays on, it will automatically turn off 30 minutes after the ignition switch has been turned to the OFF position. To turn on the light again, turn the ignition switch to the ON position.

HomeLink[®] UNIVERSAL TRANSCEIVER (if so equipped)

The HomeLink[®] Universal Transceiver provides a convenient way to consolidate the functions of up to three individual hand-held transmitters into one built-in device.

The HomeLink[®] Universal Transceiver power will automatically turn off 30 minutes after the ignition switch has been turned to the off position.

HomeLink[®] Universal Transceiver:

- Will operate most Radio Frequency (RF) devices such as garage doors, gates, home and office lighting, entry door locks and security systems.
- Is powered by your vehicle's battery. No separate batteries are required. If the vehicle's battery is discharged or is disconnected, HomeLink[®] will retain all programming.

Once the HomeLink[®] Universal Transceiver is programmed, retain the original transmitter for future programming procedures (i.e., new vehicle purchases). Upon sale of the vehicle, the programmed HomeLink[®] Universal Transceiver buttons should be erased for security purposes. For additional information, refer to "Programming HomeLink[®]" later in this section.



WARNING

- Do not use the HomeLink[®] Universal Transceiver with any garage door opener that lacks safety stop and reverse features as required by federal safety standards. (These standards became effective for opener models manufactured after April 1, 1982). A garage door opener which cannot detect an object in the path of a closing garage door and then automatically stop and reverse, does not meet current federal safety standards. Using a garage door opener without these features increases the risk of serious injury or death.
- During programming, your garage door or gate may open or close. Make sure that people and objects are clear of the garage door or gate that you are programming.
- Your vehicle's engine should be turned off while programming the HomeLink[®] Universal Transceiver.

PROGRAMMING HomeLink®

To program your HomeLink Transceiver to operate a garage door, gate, or entry door opener, home or office lighting, you need to be at the same location as the device. Note: Garage door openers (manufactured after 1996) have “rolling code protection”. To program a garage door opener equipped with “rolling code protection”; you will need to use a ladder to get up to the garage door opener motor to be able to access the “smart or learn” program button.

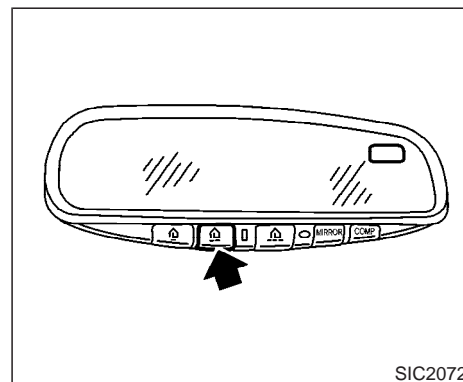
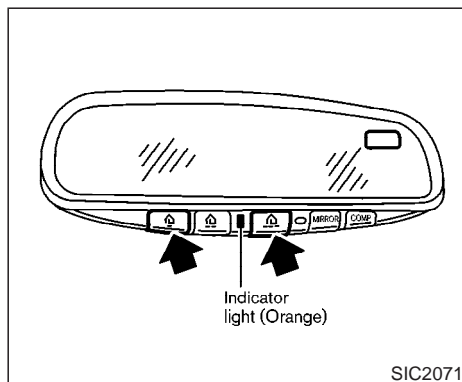

1. To begin, press and hold the 2 outer HomeLink® buttons (to clear the memory) until the indicator light blinks slowly (after 20 seconds). Release both buttons.
2. Position the end of the hand-held transmitter 1-3 inches away from the HomeLink® surface.
3. Using both hands, simultaneously press and hold both the HomeLink® button you want to program and the hand-held transmitter button.
DO NOT release the buttons until step 4 has been completed.
4. Hold down both buttons until the indicator light on the HomeLink® flashes, changing from a “slow blink” to a “rapidly flashing blink”. This could take up to 90 seconds. When the indicator light flashes rapidly, both buttons may be released. The rapidly flashing light indicates successful programming. To activate the garage door or other programmed device, press and hold the

programmed HomeLink® button - releasing when the device begins to activate.

5. If the indicator light on the HomeLink® blinks rapidly for two seconds and then turns solid, HomeLink® has picked up a “rolling code” garage door opener signal. You will need to proceed with the next steps to train the HomeLink® to complete the programming which may require a ladder and another person for convenience.
6. Press and release the “smart” or “learn” program button located on the garage door opener’s motor to activate the “training mode”. This button is usually located near the antenna wire that hangs down from the motor. If the wire originates from under a light lens, you will need to remove the lens to access the program button.

NOTE:

Once you have pressed and released the program button on the garage door opener’s motor and the “training light” is lit, you have 30 seconds in which to perform step 7. Use the help of a second person for convenience to assist when performing this step.

7. Quickly within 30 seconds of pressing and releasing the garage door opener program

button, firmly press and release the HomeLink® button you’ve just programmed. Press and release the HomeLink® button up to three times to complete the training.

8. Your HomeLink® button should now be programmed. (To program the remaining HomeLink® buttons for additional door or gate openers, follow steps 2-8 only.

NOTE:

Do not repeat step one unless you want to “clear” all previously programmed HomeLink® buttons).

If you have any questions or are having difficulty programming your HomeLink® buttons, please refer to the HomeLink® web site at: www.homelink.com or call 1-800-662-6200.

PROGRAMMING HomeLink® FOR CANADIAN CUSTOMERS

Prior to 1992, D.O.C. regulations required hand-held transmitters to stop transmitting after 2 seconds. To program your hand-held transmitter to HomeLink®, continue to press and hold the HomeLink® button (note steps 2 through 4 under “Programming HomeLink®”) while you press and re-press (“cycle”) your hand-held transmitter every 2 seconds until

the indicator light flashes rapidly (indicating successful programming).

NOTE:

If programming a garage door opener, etc., it is advised to unplug the device during the “cycling” process to prevent possible damage to the garage door opener components.

OPERATING THE HomeLink® UNIVERSAL TRANSCEIVER

The HomeLink® Universal Transceiver (once programmed) may now be used to activate the garage door, etc. To operate, simply press the appropriate programmed HomeLink® Universal Transceiver button. The red indicator light will illuminate while the signal is being transmitted.

PROGRAMMING TROUBLE-DIAGNOSIS

If the HomeLink® does not quickly learn the hand-held transmitter information:

- replace the hand-held transmitter batteries with new batteries.
- position the hand-held transmitter with its battery area facing away from the HomeLink® surface.

- press and hold both the HomeLink[®] and hand-held transmitter buttons without interruption.
- position the hand-held transmitter 2 to 5 inches (50 to 127 mm) away from the HomeLink[®] surface. Hold the transmitter in that position for up to 15 seconds. If HomeLink[®] is not programmed within that time, try holding the transmitter in another position - keeping the indicator light in view at all times.

If you continue to have programming difficulties, please contact the INFINITI Consumer Affairs Department. The phone numbers are located in the Foreword of this Owner's Manual.

CLEARING THE PROGRAMMED INFORMATION

Individual buttons cannot be cleared, however to clear all programming, press and hold the two outside buttons and release when the indicator light begins to flash (approximately 20 seconds).

REPROGRAMMING A SINGLE HomeLink[®] BUTTON

To reprogram a HomeLink[®] Universal Transceiver button, complete the following.

1. Press and hold the desired HomeLink[®] button. **Do not** release the button until step 4 has been completed.
2. When the indicator light begins to flash slowly (after 20 seconds), position the hand-held transmitter 2 to 5 inches (50 to 127 mm) away from the HomeLink[®] surface.
3. Press and hold the hand-held transmitter button.
4. The HomeLink[®] indicator light will flash, first slowly and then rapidly. When the indicator light begins to flash rapidly, release both buttons.

The HomeLink[®] Universal Transceiver button has now been reprogrammed. The new device can be activated by pushing the HomeLink[®] button that was just programmed. This procedure will not affect any other programmed HomeLink[®] buttons.

IF YOUR VEHICLE IS STOLEN

If your vehicle is stolen, you should change the codes of any non-rolling code device that has been programmed into HomeLink[®]. Consult the Owner's Manual of each device or call the manufacturer or dealer of those devices for additional information.

When your vehicle is recovered, you will need to reprogram the HomeLink[®] Universal Transceiver with your new transmitter information.

FCC Notice:

This device complies with FCC rules part 15. Operation is subject to the following two conditions: (1) This device may not cause harmful interference and (2) This device must accept any interference that may be received, including interference that may cause undesired operation.

The transmitter has been tested and complies with FCC and DOC/MDC rules. Changes or modifications not expressly approved by the party responsible for compliance could void the user's authority to operate the device.

DOC: ISTC 1763K1313

FCC I.D.: CB2V67690

MEMO

3 Pre-driving checks and adjustments

Keys (except Intelligent Key)	3-2	Hood	3-25
Infiniti vehicle immobilizer system (IVIS) keys	3-2	Back door	3-25
Doors	3-3	Auto closure	3-26
Locking with key (Driver's door only)	3-3	Fuel filler lid	3-27
Locking with inside lock knob	3-4	Open the filler lid	3-27
Locking with power door lock switch	3-4	Fuel filler cap	3-28
Child safety rear door lock	3-5	Tilting telescopic steering column	3-29
Remote keyless entry system (models without Intelligent Key system)	3-5	Automatic operation	3-29
How to use remote keyless entry system	3-5	Manual operation	3-30
Battery replacement	3-8	Sun visors	3-31
Intelligent Key system (if so equipped)	3-9	Mirrors	3-31
Door locks/unlocks precaution	3-11	Inside mirror	3-31
Intelligent Key operation	3-12	Automatic anti-glare inside mirror (if so equipped)	3-32
Opening and closing windows	3-13	Outside mirrors	3-32
Operating the engine	3-13	Automatic drive positioner (if so equipped)	3-33
Intelligent Key operating range	3-15	Memory storage function	3-33
Warning signals	3-17	Entry/exit function	3-35
Trouble-shooting guide	3-19		
Battery replacement	3-20		
Operation with intelligent remote keyless entry system	3-21		
Operation with the mechanical key and valet key	3-24		

KEYS (except Intelligent Key)

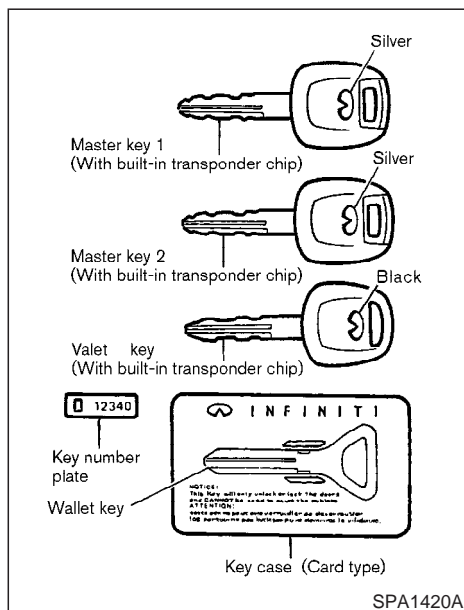

A key number plate is supplied with your keys. Record the key number and keep it in a safe place (such as your wallet), not in the vehicle. If you lose your keys, see an INFINITI dealer for duplicates by using the key number.

A key number is necessary when you have lost

3-2 Pre-driving checks and adjustments

all keys and do not have one to duplicate from. If you still have a key, your INFINITI dealer can duplicate it.

INFINITI VEHICLE IMMOBILIZER SYSTEM (IVIS) KEYS

You can only drive your vehicle using the master or valet keys which are registered to the INFINITI Vehicle Immobilizer System components in your vehicle. These keys have a transponder chip in the key head.

The master key can be used for all the locks.

The valet key cannot be used for glove box lock.

To protect belongings when you leave a key with someone, give them the valet key only.

Never leave these keys in the vehicle.

INFINITI Vehicle Immobilizer System KEY — Master and Valet keys:

If you still have a key, the key number is not necessary when you need extra INFINITI Vehicle Immobilizer System keys. Your INFINITI dealer can duplicate it. As many as 5 IVIS keys can be used with one vehicle. You should bring all IVIS keys that you have to your INFINITI dealer for registration. This is because the registration process will erase the memory of all key codes previously registered

into the INFINITI Vehicle Immobilizer System. After the registration process, these components will only recognize keys coded into the INFINITI Vehicle Immobilizer System (IVIS) during registration. Any key that is not given to your dealer at the time of registration will no longer be able to start your vehicle.

Do not allow the immobilizer system key, which contains an electrical transponder, to come into contact with salt water. This could affect system function.

DOORS



WARNING

- Always have the doors locked while driving. Along with the use of seat belts, this provides greater safety in the event of an accident by helping to prevent persons from being thrown from the vehicle. This also helps keep children and others from unintentionally opening the doors, and will help keep out intruders.
- Before opening any door, always look for and avoid oncoming traffic.
- Do not leave children unattended inside the vehicle. They could unknowingly activate switches or controls. Unattended children could become involved in serious accidents.

If your vehicle is equipped with a Intelligent Key system, please refer to “Intelligent Key system” later in this section.

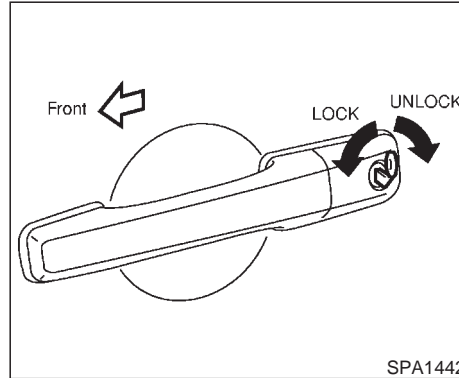

LOCKING WITH KEY (Driver's door only)

The power door lock system allows you to lock or unlock all doors simultaneously.

- Turning the driver's door key with the metal key (master key, mechanical key, valet key and wallet key) toward the front of the vehicle will lock all doors.
- Turning the driver's door key one time to the rear of the vehicle will unlock the corresponding door. From that position, returning the key to neutral (where the key can only be removed and inserted.) and turning

it to the rear again within 5 seconds will unlock all doors. (including the back door) and fuel filler lid.

Opening and closing windows

The driver's door key operation allows you to open and close the front door windows simultaneously.

- To open the windows, turn the driver's door key to the rear of the vehicle for **longer than 1 second** after the door is unlocked.
- To close the windows, turn the driver's door key to the front of the vehicle for **longer than 1 second** after the door is locked.

The door windows will open or close while turning the driver's door key. This function will operate after the ignition switch is off and 45 seconds have passed or till either of the front doors is opened.

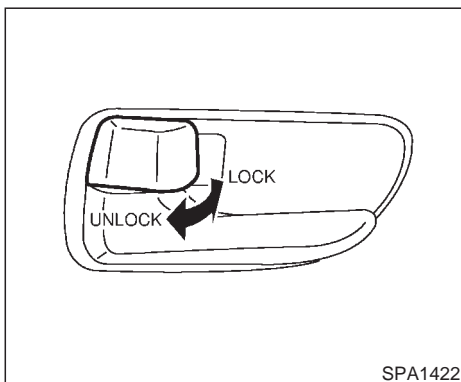

LOCKING WITH INSIDE LOCK KNOB

To individually lock the doors, move the inside lock knob to the LOCK position, then close the door. To unlock, pull up the inside lock knob to the UNLOCK position.

When locking the door without a key, be sure not to leave the key inside the vehicle.

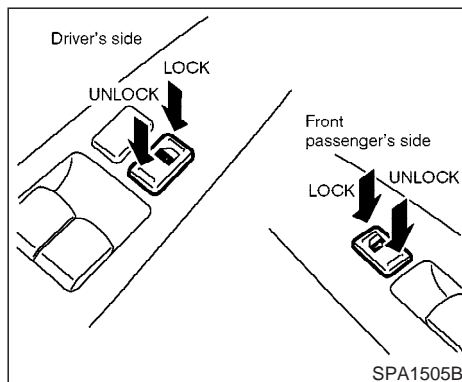

LOCKING WITH POWER DOOR LOCK SWITCH

All door locks will be engaged when the power door lock switch is moved to the LOCK position with the driver's or front passenger's door open. Then close the door and all doors will be locked.

Lockout protection

When the power door lock switch (driver or front passenger) is moved to the lock position with the key in the ignition and any door open, all doors will lock and unlock automatically. This helps to prevent the keys from being

accidentally locked inside the vehicle.

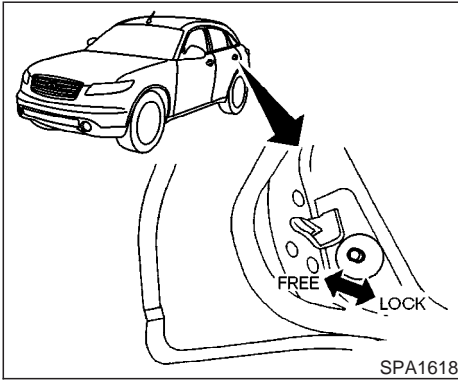

CHILD SAFETY REAR DOOR LOCK

Child safety locking helps prevent doors from being opened accidentally, especially when small children are in the vehicle.

When the lever is in the LOCK position, the rear door can be opened only from the outside.

REMOTE KEYLESS ENTRY SYSTEM (models without Intelligent Key system)

It is possible to lock/unlock all doors (including the back door) and fuel filler lid and activate the panic alarm by using the keyfob from outside the vehicle.

Before locking the doors, make sure the key is not left in the vehicle.

The keyfob can operate at a distance of approximately 33 ft (10 m) from the vehicle. (The effective distance depends upon the conditions around the vehicle.)

As many as 4 keyfobs can be used with one vehicle. For information concerning the purchase and use of additional keyfob, contact your INFINITI dealer.

The keyfob will not function when:

- the battery is completely discharged,
- the distance between the vehicle and the keyfob is over 33 ft (10 m).

The panic alarm will not activate when the key is in the ignition switch.



CAUTION

The following conditions or occurrences will damage the keyfob.

- Do not allow the keyfob to become wet.
- Do not drop the keyfob.
- Do not strike the keyfob sharply against another object.
- Do not place the keyfob for an extended period in an area where temperatures exceed 140°F (60°C).

If a keyfob is lost or stolen, INFINITI recommends erasing the ID code of that keyfob. This will prevent the keyfob from unauthorized use to unlock the vehicle. For information regarding the erasing procedure, please contact an INFINITI dealer.

HOW TO USE REMOTE KEYLESS ENTRY SYSTEM

Setting hazard indicator and horn mode

This vehicle is set in hazard indicator and horn mode when you first receive the vehicle.

In hazard indicator and horn mode, when the

LOCK button is pushed, the hazard indicator flashes twice and the horn chirps once. When the UNLOCK button is pushed, the hazard indicator flashes once.

If hazard indicator and horn mode is not necessary, you can switch to hazard indicator only mode by following the switching procedure.

In hazard indicator only mode, when the LOCK button is pushed, the hazard indicator flashes twice. When the UNLOCK button is pushed, neither the hazard indicator nor the horn operates.

(Switching procedure)

Push the LOCK and UNLOCK buttons on the keyfob simultaneously for more than 2 seconds to switch from one mode to the other.

When pushing the buttons to set hazard indicator only mode, the hazard indicator flashes 3 times.

When pushing the buttons to set hazard indicator and horn mode, the hazard indicator flashes once and the horn chirps once.

OPERATION GUIDE			
MODE (Push "LOCK" and "UNLOCK" buttons for more than 2 seconds to switch)	Switching indicator	LOCK	UNLOCK
Hazard indicator and horn → HAZARD INDICATOR ONLY	HAZARD – 3 times	HAZARD – twice	No operation
Hazard indicator only → HAZARD INDICATOR AND HORN	HAZARD – once HORN – once	HAZARD – twice HORN – once	HAZARD – once

SPA1260

The hazard indicator and horn mode also can be changed with vehicle electronic systems on the monitor. See "4. Display screen, heater, air conditioner and audio systems".

Locking doors and fuel filler lid

1. Remove the ignition key.*1,*2
2. Close all the doors.*3
3. Push the LOCK button on the keyfob.
4. All the doors and fuel filler lid will lock.

All of the doors will lock when the LOCK button on the keyfob is pushed even though a door remains open and/or the

ignition key is in the ON position.

5. The hazard indicator flashes twice and the horn chirps once.
 - When the LOCK button is pushed with all doors locked, the hazard indicator flashes twice and the horn chirps once as a reminder that the doors are already locked.

*1: Doors lock with the keyfob while a key is in the ignition switch. However, the panic alarm will not activate when the key is in the ignition switch.

*2: Doors lock with the keyfob while the igni-

tion switch is in the ON position. However, the hazard indicator and horn will not function.

*3: Doors lock with the keyfob while any door is open. However, the hazard indicator and horn will not function.

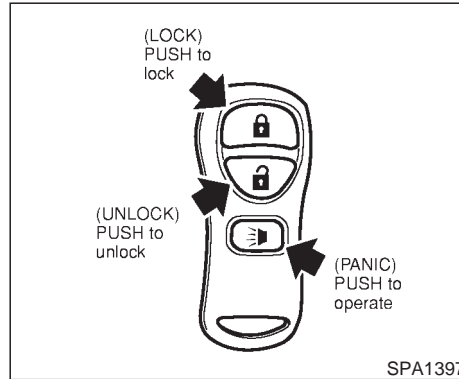

Unlocking doors and fuel filler lid

1. Push the UNLOCK button on the keyfob once.
 - The driver's door and fuel filler lid unlock
 - The hazard indicator flashes once if all doors are completely closed with the ignition key in any position except the ON position.
 - The interior light turns on and the light timer activates for 30 seconds when the switch is in the DOOR position with the ignition key in any position except the ON position.

2. Push the UNLOCK button on the keyfob again within 5 seconds.

- All doors unlock
- The hazard indicator flashes once if all doors are completely closed.

All doors will be locked automatically unless one of the following operations is performed within 1 minute of pressing the UNLOCK button.

- any door is opened
- the ignition switch is turned to the ON position

The interior light can be turned off without waiting for 30 seconds by turning the ignition switch to the ON position or by locking the doors with the keyfob.

Opening the windows

Push the UNLOCK button on the keyfob.

The driver's door will unlock.

Continue to press the UNLOCK button for 3 seconds. The door windows will be lowered.

Continue to press the UNLOCK button until windows are fully open.

To stop lowering the windows, release the UNLOCK button.

To start lowering the windows, press the UNLOCK button again for more than 3 seconds.

The rear door windows will operate 0.5 seconds after the front windows' operation. (if so equipped)

Using the panic alarm

If you are near your vehicle and feel threatened, you may activate the alarm to call attention as follows:

1. Push the PANIC button on the keyfob for **longer than 0.5 seconds** with the key removed from the ignition key cylinder.
2. The theft warning alarm and headlights will stay on for 30 seconds.
3. The panic alarm stops when:
 - It has run for 30 seconds, or
 - The LOCK or the UNLOCK button is pressed, or
 - The PANIC button is pushed on the keyfob for longer than 0.5 seconds.

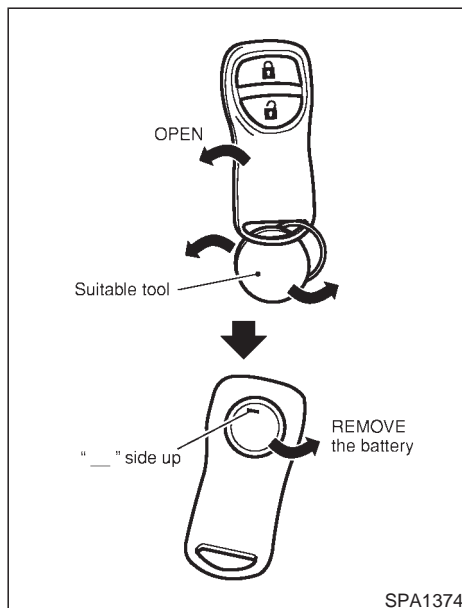

BATTERY REPLACEMENT

Replace the battery as follows:

1. Open the lid using a suitable tool.
2. Replace the battery with a new one.

Recommended battery: CR2025 or equivalent

Make sure that the ⊕ side faces the bottom case.

3. Close the lid securely.
4. Push the keyfob button two or three times to check its operation.

See your INFINITI dealer if you need any assistance for replacement.

If the battery is removed for any reason other than replacement, perform step 4 above.

- Be careful not to touch the circuit board and the battery terminal.
- An improperly disposed battery can harm the environment. Always confirm local regulations for battery disposal.
- The keyfob is water-resistant; however, if it gets wet, immediately wipe it completely dry.
- When changing batteries, do not let dust or oil get on the keyfob.

FCC Notice:

Changes or modifications not expressly approved by the manufacturer compliance

could void the user's authority to operate the equipment. This device complies with Part 15 of the FCC Rules and RSS-210 of Industry Canada. Operation is subject to the following two conditions: (1) This device may not cause harmful interference, and (2) this device must accept any interference received, including interference that may cause undesired operation of the device.

INTELLIGENT KEY SYSTEM (if so equipped)

The Intelligent Key uses coded radio signals to communicate with the vehicle. When the Intelligent Key is near the vehicle, such as in your pocket or purse, it allows the vehicle to be locked, unlocked, or started without inserting the ignition key. It is also possible to use the remote control entry function.



CAUTION

- Be sure to carry the Intelligent Key with you.
 - Do not leave the vehicle with the Intelligent Key inside.
-
- The Intelligent Key may not function correctly depending on the environment or operating conditions. It could also malfunction if you do not use it correctly.
 - The Intelligent Key transmits faint radio waves.
- In the following situations, the Intelligent Key and remote control entry functions may not operate correctly, and you may have to use the metal key (mechanical key, valet key or wallet key):

- when there are strong signals coming from a television tower, power station or broadcasting station.
 - when you have wireless equipment or a cellular phone with you.
 - when the Intelligent Key is in contact with or covered by a metallic material.
 - when radio wave-type remote control entry is used nearby.
 - when the Intelligent Key is placed near an electric appliance such as a personal computer.
-
- The Intelligent Key continually consumes battery power as the key receives a signal to communicate with the vehicle. Battery life is about 2 years, although it varies depending on the operating conditions. When the battery of the Intelligent Key is low, the green blinking key warning light goes out about 30 seconds after the ignition knob is turned to ON. If the battery runs down, replace it with a new one.
 - If the Intelligent Key receives strong signal over an extended period of time, the battery could quickly run down. Do not place the Intelligent Key near an electric appliance such as a television

set or personal computer.

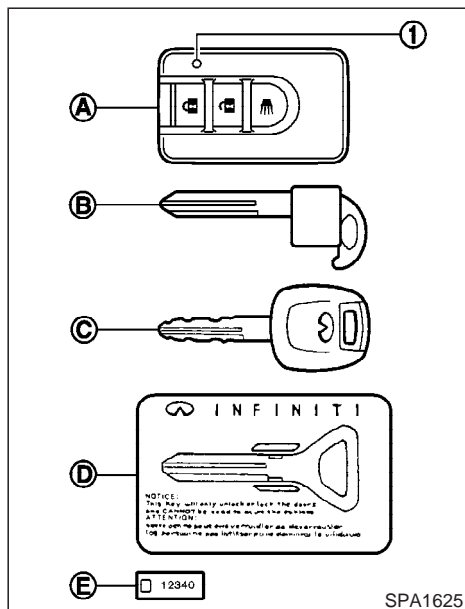

- (A) Intelligent Key 2 sets
- (B) Mechanical key (metal key) 2 sets
- (C) Valet key (metal key) 1 set
- (D) Wallet key and key case (card type)
(metal key) 1 set
- (E) Key number plate 1 set



WARNING

- The Intelligent Key transmits radio waves that can adversely affect medical electric equipment.
- If you have a pacemaker, you should contact the medical equipment manufacturer to ask if it will be affected by the Intelligent Key signal.

The valet key cannot be used for the glove box lock.

To protect belongings when you leave a key with someone, give them the valet key only.

Record the key number on the key number plate/metal tag and keep it in a safe place (such as your wallet), NOT IN THE VEHICLE. A key number plate is supplied with your key. Keep the plate in a safe place. INFINITI does not record key numbers so it is very important to keep track of your key number plate.

As many as 4 Intelligent Key can be used with one vehicle. For information concerning the purchase and use of additional remote controllers, contact your INFINITI dealer.

If the indicator light ① does not come on after

pushing the Intelligent Key lock or unlock button, the battery may be run down or malfunctioning. Contact your INFINITI dealer.

It is possible that the Intelligent Key functions can become cancelled.



CAUTION

Be sure to carry the Intelligent Key with you when driving. The Intelligent Key is a precision device with a built-in transmitter. To avoid damaging it, please note the following.

- The Intelligent Key is water resistant, wetting may damage the Intelligent Key. If the Intelligent Key gets wet, immediately wipe until it is completely dry.
- Do not bend, drop or strike it against another object.
- Do not place the Intelligent Key for an extended period in a place where temperatures exceed 140°F (60°C).
- Do not change or modify the Intelligent Key.

- Do not use a magnet key holder.
- Do not place the Intelligent Key near an electric appliance such as a television set or personal computer.

If an Intelligent Key is lost or stolen, INFINITI recommends erasing the ID code of that Intelligent Key. This will prevent the Intelligent Key from unauthorized use to unlock the vehicle. For information regarding the erasing procedure, please contact an INFINITI dealer.

DOOR LOCKS/UNLOCKS PRECAUTION

- After locking with the door handle request switch, make sure the doors are securely locked.
- To prevent the Intelligent Key from being left inside the vehicle, make sure you carry the key with you and then lock the doors.
- You can lock or unlock the doors using only the door handle, which detects the Intelligent Key.

- It is not possible to lock the doors with the lock knob when the driver's door is open, the ignition knob is pushed in or the metal key is in the ignition knob.
- When you try to unlock the door while pulling the door handle, the door may not unlock. In this case, release the door handle and the door will unlock. Pull the door handle again and the door will open.
- The outside beep, which indicates the lock and unlock functions, can be canceled with the LOCK/UNLOCK button on the Intelligent Key and the vehicle electronic system on the monitor. See "4. Display screen, heater, air conditioner and audio systems".

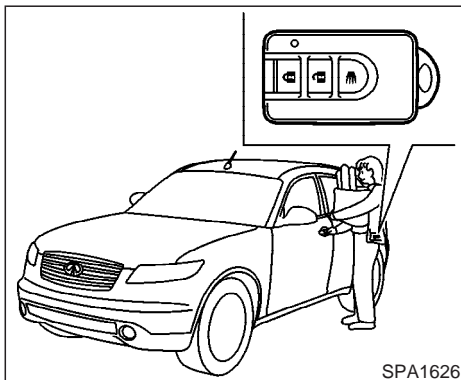

INTELLIGENT KEY OPERATION

You can lock or unlock the doors without taking the key out from your pocket or purse.

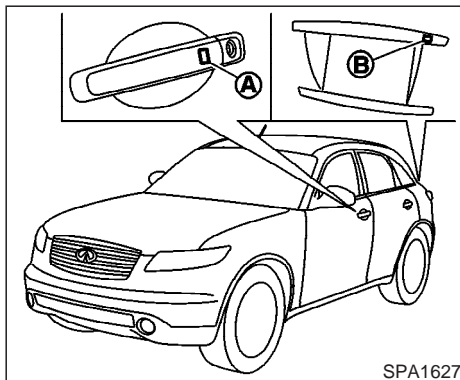

When you carry the Intelligent Key with you, you can lock or unlock all doors by pushing the door handle request switch (A) or back door handle request switch (B) within the range of operation.

Locking doors

1. Turn the ignition knob to the LOCK position and remove the ignition key if any metal key is in the ignition knob.*1, *2
2. Close all the doors.*3
3. Push any front door or the back door handle request switch while carrying the Intelligent Key with you.*4

4. All the doors, back door and fuel filler lid will lock.
5. The hazard indicator flashes twice and door buzzer sounds twice.

The hazard indicator and horn mode also can be changed with vehicle electronic systems on the monitor. See “4. Display screen, heater, air conditioner and audio systems”.

- *1: Doors lock with the Intelligent Key while a mechanical key or valet key is in the ignition switch.
- *2: Doors lock with the Intelligent Key while the ignition switch is not in the LOCK position.
- *3: Doors do not lock with the door handle request switch or the LOCK button on the Intelligent Key while any door is open. A beep sounds to warn you. However, doors lock with the metal key even if any door is open.
- *4: Doors do not lock with door handle request switch with the Intelligent Key inside the vehicle and a beep sounds to warn you. However, when an Intelligent Key is inside the vehicle, doors can be locked with another Intelligent Key.

Unlocking doors

1. Push the door handle request switch once.

Driver's side:

- The driver door and fuel filler lid unlock.

Front passenger side or back door:

- Only corresponding door unlocks.
2. The hazard indicator flashes once and door buzzer sounds once if all doors are completely closed with the ignition key in any position except the ON position.
3. Push the door handle request switch again within 5 seconds.
- All doors and the fuel filler lid unlock.
 - The hazard indicator flashes once and door buzzer sounds once if all doors are completely closed.

All doors will be locked automatically after pressing the unlocking button unless one of the following operations is performed within 1 minute.

- any door is opened
- the ignition knob is pushed
- the mechanical key or the valet key is inserted into the ignition knob

The interior light, ceiling light (if so equipped) and step light can be turned off without waiting for 30 seconds by turning the ignition switch to the ON position or by locking the doors.

OPENING AND CLOSING WINDOWS

- To open the windows, push the UNLOCK button on the Intelligent Key for about 3 seconds or turn the driver's door key lock with the metal key to the rear of the vehicle for **about 2 seconds** after the door is unlocked.

To stop opening, release the UNLOCK button or turn the key to the neutral position.

- To close the windows turn the driver's door key lock to the front of the vehicle for **about 2 seconds** after the door is locked.

To stop closing, turn the key to the neutral position.

The door windows will open or close while turning the metal key. This function will operate after the ignition switch is off and 45 seconds have passed or till either of the front doors is opened.

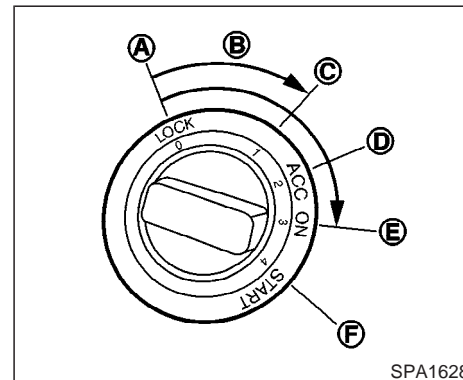

SPA1628

OPERATING THE ENGINE

Ignition knob positions

Push in the ignition knob in the (B) range when you turn it.

LOCK (Normal parking position) (A):

The ignition knob can only be locked in the (A) position.

The ignition knob will be unlocked when it is pushed in, and turned to the ACC position (D) while carrying the Intelligent Key.

ACC (Accessories) (D):

This position activates electrical accessories such as the radio, when the engine is not running.

ON (Normal operating position) (E):

This position turns on the ignition system and electrical accessories.

START (F):

This position starts the engine. As soon as the engine has started, release the knob immediately. It will automatically return to the ON position.

For important safety information, see “Ignition knob” in the “5. Starting and driving” section.

The ignition knob cannot be turned back to the LOCK position unless the shift lever is in P position. (It can be turned to only (C))



CAUTION

Do not leave the vehicle with the ignition knob in ACC or ON positions when the engine is not running for an extended period. This can discharge the battery.

Starting the engine

When driving the vehicle, be sure to carry the Intelligent Key with you.

1. Securely depress the brake pedal.

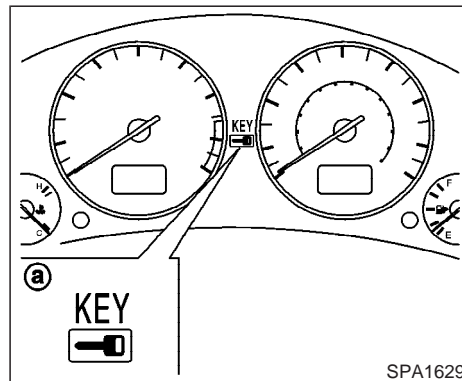

2. Slowly push the ignition knob in. When the Intelligent Key warning light (a) in the instrument panel comes on in green, the ignition knob can be turned.
3. Turn the ignition knob to START and the engine will be started.
4. When the engine starts, release the ignition knob.



WARNING

Do not start the engine from outside the

vehicle through the window. Doing so could lead to an accident and injury. Be sure to sit in the driver's seat to use the key.

For important safety information, see “Starting the engine” in the “Starting and driving” section.

- When the ignition knob is pushed under the following conditions, the key warning light in the instrument panel comes on in red. It is not possible to turn the ignition knob when:
 - you do not have the Intelligent Key with you
 - the Intelligent Key battery has run down
 - you have a Intelligent Key for another vehicle with you
- Slowly turn the ignition knob after the key warning light comes on in green. If it is turned quickly, it may stick and be difficult to turn.
- The engine may not start if the Intelligent Key is placed:
 - inside the glove box or the door pocket
 - on the instrument panel

- in the corner of interior compartment.
- If it is difficult to turn the ignition knob, perform the following:
 - Push the ignition knob again and slowly turn it.
 - Turn the ignition knob while gently turning the steering wheel to the left or right.

Stopping the engine

1. Shift the selector lever to the P position.
2. Turn the ignition knob to ACC.



WARNING

When you leave the vehicle, be sure to observe the following:

- **Shift the selector lever to P. (In other positions, the ignition knob will not return to LOCK.)**
- **Securely return the ignition knob to LOCK.**
- **Set the parking brake. Failure to do so could result in unexpected vehicle**

movement and could lead to severe injury.

INTELLIGENT KEY OPERATING RANGE

The Intelligent Key functions can be used only when you carry the key with you and operate as specified in the operating range inside or outside the vehicle.

When the Intelligent Key battery runs down or where there are strong radio waves or noise, the operating range may be narrower or the key may be inoperative.

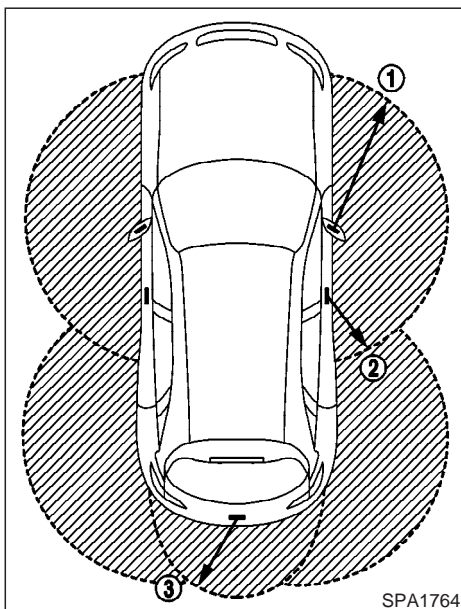

Operating range of the door lock/unlock function

The outside sensors are in the outside mirrors and the back door.

The operating range of the door lock/unlock function is shown in the illustration.

Front door:

- ① 39.4 in (1 m) from the outside mirror
- ② 15.75 in (40 cm) from the door handle

Back door:

- ③ 31.5 in (80 cm) from the door handle
- If you are too close to the door glass, the Intelligent Key may not operate.
- If the Intelligent Key is in the operating range, it is possible for anyone who does not carry the Intelligent Key to lock/unlock the doors by pushing the door handle request switch.

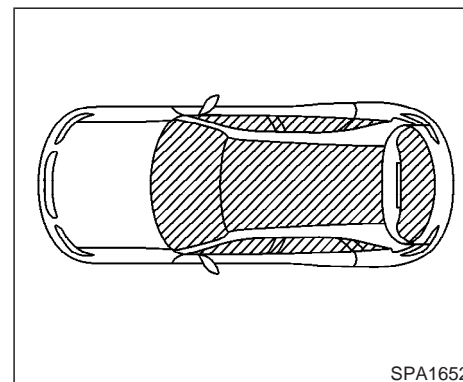

Operating range for engine start function

The operating range for starting the engine is inside the vehicle.

- If the Intelligent Key is on the instrument panel, inside the glove box or door pocket, or the corner of interior compartment, it may not be possible to start the engine.
- If the Intelligent Key is near the door or door glass outside the vehicle, it may be possible to start the engine.

WARNING SIGNALS

To help prevent the vehicle from moving unexpectedly by erroneous operation of the Intelligent Key or to help prevent the vehicle from being stolen, chime or beep sounds inside and outside the vehicle and a warning light comes on in the instrument panel.

When a chime or beep sounds or the warning light comes on, be sure to check the vehicle and Intelligent Key.

Alarm and warning when locking the doors

When the front door warning chime or beep sounds, check for the following:

- The ignition knob is turned to LOCK.
- The Intelligent Key is not left inside the vehicle.
- Doors are closed securely.
- The selector lever is in the P position.

The door beep sounds for about 2 seconds.

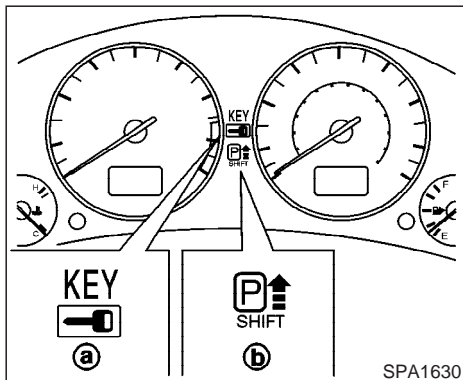

Alarm and warning when the engine stops

When the P position selecting warning light (b) in the instrument panel blinks in red:

- Make sure the selector lever is in the P position.

When the chime sounds intermittently:

- Make sure the selector lever is in the P position and the ignition knob is turned to LOCK.

If the chime sounds continuously when the driver's door is opened, check the following:

- The selector lever is in the P position and the ignition knob is turned to LOCK.
- The mechanical key or the valet key is not inserted into the ignition knob.
- The inside warning chime may stop when one of the following is performed.
 - Returning the ignition knob to LOCK.
 - Removing the mechanical key or the valet key.
 - Closing the doors.

Alarm and warning when the engine starts

When the key warning light (a) is blinking in red and the outside buzzer sounds, make sure the Intelligent Key is inside the vehicle.

The buzzer will stop 3 seconds after the Intelligent Key is returned to the vehicle.

Warning for low battery power

- This warning is to let you know that the battery of the Intelligent Key will run down soon. Replace it with a new one.
 - The green blinking key warning light (a) goes out about 30 seconds after the ignition knob is turned to ON.

- We recommend replacing the battery at your INFINITI dealer.

Preventing the Intelligent Key from being left in the vehicle

If you lock all doors using the power door lock switch with the Intelligent Key in the vehicle, all of the doors unlock immediately and the beep sounds to warn you when the door is closed.

TROUBLE-SHOOTING GUIDE

Symptom		Possible Cause	Remedy
When pushing the door handle request switch	The front door beep sounds for approximately 2 seconds	The doors cannot be locked.	Take out the Intelligent Key from the vehicle and push the door handle request switch.
			Turn the ignition knob to LOCK and push the door handle request switch carrying the Intelligent Key with you.
			Close all doors securely and push the door handle request switch carrying the Intelligent Key with you.
When closing the doors	The front door beep sounds for approximately 10 seconds	The ignition knob is not turned to LOCK position.	Turn the ignition knob to LOCK.
	The key warning light in the instrument panel blinks in red and the front door warning beep sounds for approximately 3 seconds.	The Intelligent Key is taken out from the vehicle.	Be sure to carry the Intelligent Key with you.
	The front door beep sounds for approximately 3 seconds and all doors unlock.	The Intelligent Key is left in the vehicle.	Take out the Intelligent Key from the vehicle and close the door.
When opening the driver's door	A warning chime sounds continuously	The ignition knob is not in LOCK position, or the mechanical key or valet key is inserted into the ignition knob.	Turn the ignition knob to LOCK. Remove the mechanical key or valet key from the ignition knob.
		The selector lever is not in the P position.	Make sure that the selector lever is in the P position.
When stopping the engine	The P position warning light in the instrument panel blinks in red.	The selector lever is not in the P position.	Make sure that the selector lever is in the P position.
	The warning chime sounds	The ignition knob is not turned to LOCK.	Turn the ignition knob to LOCK.
When starting the engine	The key warning light in the instrument panel blinks in green.	The battery charge is low.	Replace the battery to new one. See "BATTERY REPLACEMENT" on page 3-20.

Trouble-shooting examples

When it is difficult to turn the ignition knob

- Push the ignition knob again and turn it slowly.
- While gently turning the steering wheel to the left or right, turn the ignition knob.

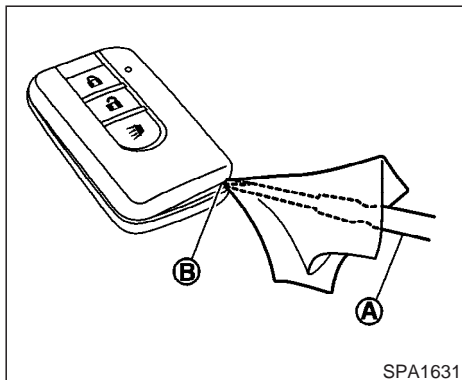

BATTERY REPLACEMENT



CAUTION

Be careful not to allow children to swallow the battery and removed parts.

Replace the battery as follows:

1. Insert a flat-blade screwdriver (A) wrapped with a cloth into the slit (B) of the corner and twist it to separate the upper part from the lower part.

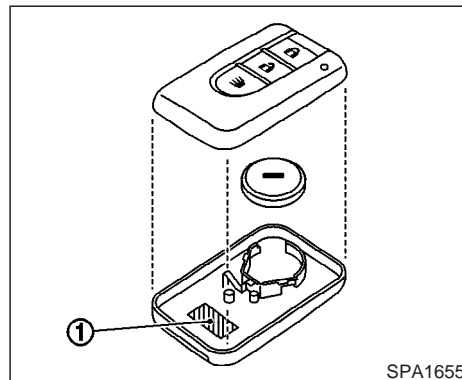

2. Replace the battery with a new one.

- Do not touch the internal circuit and electric terminals as it could cause a malfunction.

Recommended battery: CR2032 or equivalent

Make sure that the ⊕ side faces the bottom of the case.

3. Close the lid securely.
4. Push the buttons two or three times to check its operation.

See your INFINITI dealer if you need any assistance for replacement.

If the battery is removed for any reason other than replacement, perform step 3 above.

- Be careful not to touch the circuit board and the battery terminal.
- An improperly disposed battery can harm the environment. Always confirm local regulations for battery disposal.
- When changing batteries, do not let dust or oil get on the Intelligent Key.

FCC Notice:

This equipment has been tested and found to comply with the limits for a Class B digital device pursuant to part 15 of the FCC Rules (①: the certification number). These limits are designed to provide reasonable protection against harmful interference in a residential installation. This equipment generates, uses and can radiate radio frequency energy and, if not installed and used in accordance with the instructions, may cause harmful interference to radio communications. However, there is no guarantee that interference will not occur in a particular installation. If this equipment does cause harmful interference to radio or television reception, which can be determined by turning the equipment off

and on, the user is encouraged to try to correct the interference by one or more of the following measures:

- Reorient or relocate the receiving antenna
- Increase the separation between the equipment and the receiver
- Connect the equipment into an outlet on a circuit different from that to which the receiver is connected.
- Consult the dealer or an experienced radio/TV technician for help.

OPERATION WITH INTELLIGENT REMOTE KEYLESS ENTRY SYSTEM

It is possible to lock/unlock all doors, fuel filler lid, activate the panic alarm and open the windows by pushing the buttons on the Intelligent Key from outside the vehicle.

Before locking the doors, make sure the key is not left in the vehicle.

The LOCK/UNLOCK button on the Intelligent Key can operate at a distance of approximately 33 ft (10 m) from the vehicle. (The effective distance depends upon the conditions around the vehicle.)

As many as 4 Intelligent Key can be used with one vehicle. For information concerning the purchase and use of additional Intelligent Key, contact your INFINITI dealer.

The lock and unlock buttons on the Intelligent Key will not operate when:

- the Intelligent Key is too far away from the vehicle
- the Intelligent Key battery runs down

After locking with the remote control entry function, pull the door handle to make sure the doors are securely locked.

The operating range varies depending on the environment. To securely operate the lock and unlock buttons, approach the vehicle to about 1 m (3 ft) from the door.

The panic alarm will not activate when the mechanical key or the valet key is in the ignition knob.

How to use remote keyless entry system

Setting hazard indicator and horn mode:

This vehicle is set in hazard indicator and horn mode when you first receive the vehicle.

The hazard indicator and horn mode also

can be changed with vehicle electronic systems on the monitor. See “4. Display screen, heater, air conditioner and audio systems”.

In hazard indicator and horn mode, when the LOCK button is pushed, the hazard indicator flashes twice and the horn chirps once. When the UNLOCK button is pushed, the hazard indicator flashes once.

If hazard indicator and horn mode is not necessary, you can switch to hazard indicator only mode by following the switching procedure.

In hazard indicator only mode, when the LOCK button is pushed, the hazard indicator flashes twice. When the UNLOCK button is pushed, neither the hazard indicator nor the horn operates.

(Switching procedure)

Push the LOCK and UNLOCK buttons on the keyfob simultaneously for more than 2 seconds to switch from one mode to the other.

When pushing the buttons to set hazard indicator only mode, the hazard indicator flashes 3 times.

When pushing the buttons to set hazard indicator and horn mode, the hazard indicator flashes once and the horn chirps once.

3-22 Pre-driving checks and adjustments

OPERATION GUIDE			
MODE (Push "LOCK" and "UNLOCK" buttons for more than 2 seconds to switch)	Switching indicator	LOCK	UNLOCK
Hazard indicator and horn → HAZARD INDICATOR ONLY	HAZARD – 3 times	HAZARD – twice	No operation
Hazard indicator only → HAZARD INDICATOR AND HORN	HAZARD – once HORN – once	HAZARD – twice HORN – once	HAZARD – once

SPA1260

Locking doors and fuel filler lid:

1. Remove the mechanical key or the valet key if any key is in the ignition knob.*1
2. Close all the doors.*2
3. Push the LOCK button (A) on the Intelligent Key.
4. All the doors (including back door) and fuel filler lid will lock.

All of the doors will lock when the LOCK button on the Intelligent Key is pushed even though the ignition knob is in the ON position.

5. The hazard indicator flashes twice and the horn chirps once.
 - When the LOCK button is pushed with all doors locked, the hazard indicator flashes twice and the horn chirps once as a reminder that the doors are already locked.

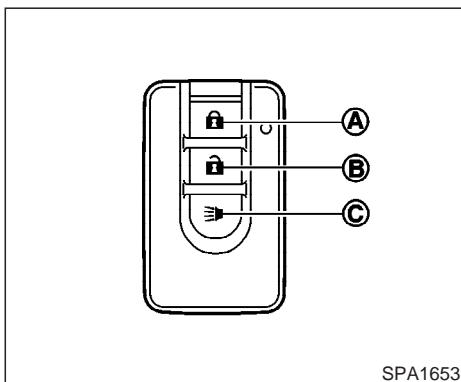

*1: Doors lock with the Intelligent Key while the mechanical key or the valet key is in the ignition knob or the ignition knob is pushed in.

*2: Doors do not lock with the Intelligent Key while any door is open.

Unlocking doors and fuel filler lid:

1. Push the UNLOCK button (B) on the Intelligent Key once.
 - The driver's door and fuel filler lid unlock
 - The hazard indicator flashes once if all doors are completely closed with the igni-

tion knob in any position except the ON position.

- The interior light turns on and the light timer activates for 30 seconds when the switch is in the DOOR position with the ignition knob in any position except the ON position.
2. Push the UNLOCK button on the Intelligent Key again within 5 seconds.
 - All doors unlock.
 - Back door unlocks.
 - The hazard indicator flashes once if all doors are completely closed.

All doors will be locked automatically unless one of the following operations is performed within 1 minute of pressing the UNLOCK button.

- any door is open
- the ignition knob is pushed
- the mechanical key or the valet key is inserted into the ignition knob

The interior light can be turned off without waiting for 30 seconds by turning the ignition switch to the ON position or by locking the doors with the Intelligent Key.

Opening the windows:

See "Opening and closing windows" on the previous page.

Using the panic alarm:

If you are near your vehicle and feel threatened, you may activate the alarm to call attention as follows:

1. Push the PANIC button (C) on the Intelligent Key for **longer than 0.5 seconds** with the metal key removed from the ignition key cylinder or the ignition knob pushed in.
2. The theft warning alarm and headlights will stay on for 25 seconds.
3. The panic alarm stops when:
 - It has run for 25 seconds, or
 - The LOCK or the UNLOCK button is pressed, or
 - The PANIC button is pushed on the Intelligent Key for longer than 0.5 seconds.

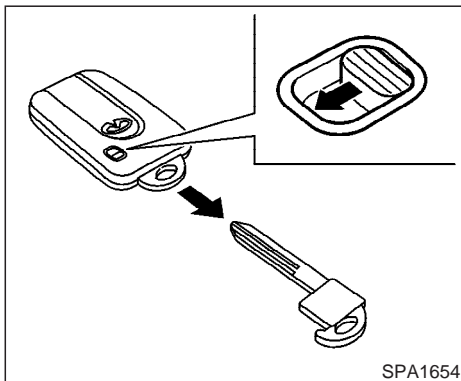

OPERATION WITH THE MECHANICAL KEY AND VALET KEY

If the Intelligent Key cannot be used because its battery is discharged, use the metal key to lock or unlock the doors and use the mechanical key or the valet key, which is registered to the INFINITI Vehicle Immobilizer System components, to start the engine.

Removing the mechanical key

- Release the lock knob at the back of the intelligent key and remove the mechanical key.

3-24 Pre-driving checks and adjustments

- To install the mechanical key to the intelligent key, securely lock the lock knob and then check that the mechanical key will not move.



CAUTION

Be sure to carry the Intelligent Key with the mechanical key installed in it.

Locking/unlocking the doors with the metal key (mechanical key, valet key and wallet key)

The doors can be locked/unlocked by inserting the metal key into the key cylinder in the driver's door in the same way as the ordinary key.

Starting the engine with the mechanical key

1. Securely depress the brake pedal.
2. Insert the mechanical key or the valet key into the ignition knob.

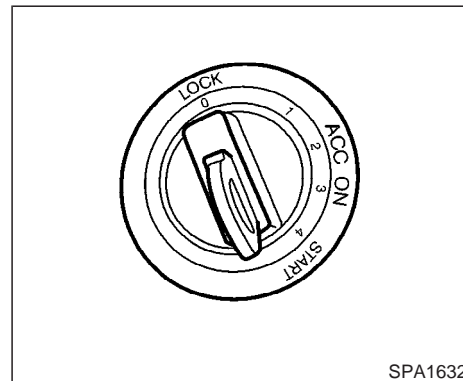

3. Turn the ignition knob to START and start the engine.
4. After starting the engine, release the knob.

When the engine is off, the steering wheel lock cannot be unlocked.

For important safety information, see the "5. Starting and driving" section.

Windows open/close with the mechanical key

See "Opening and closing windows" on the previous page.

HOOD

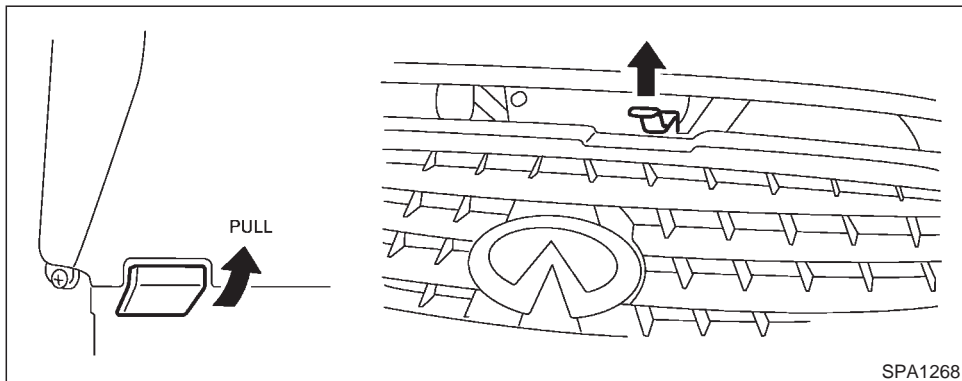

1. Pull the hood lock release handle located below the instrument panel; the hood will then spring up slightly.
2. Pull the lever at the front of the hood with your fingertips and raise the hood.
3. When closing the hood, lower it slowly and make sure it locks into place.



WARNING

- **Make sure the hood is completely closed and latched before driving. Failure to do so could cause the hood to fly open and result in an accident.**
- **If you see steam or smoke coming from the engine compartment, to avoid injury do not open the hood.**

BACK DOOR

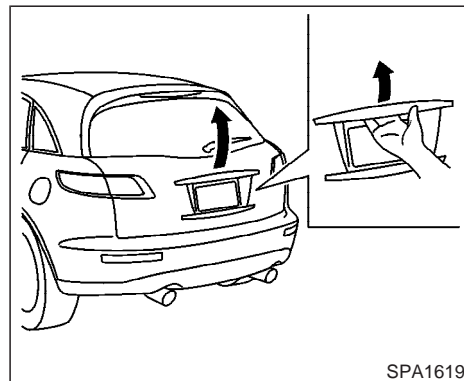

- The power door lock system allows you to lock or unlock all doors including the back door simultaneously.
- Push the opener switch and pull the opener handle to open the back door.



WARNING

Do not drive with the back door open. This could allow dangerous exhaust gases to be drawn into the vehicle. See “Precautions when starting and driving”

in the “5. Starting and driving” section for exhaust gas.

AUTO CLOSURE

If the back door is pulled down to a partly open position, the back door will pull itself to the closed position.

Do not apply excessive force when the auto closure is operating. Excessive force applied may cause the mechanism to malfunction.



CAUTION

- **The back door will automatically close from a partly open position. To avoid pinching, keep hands and fingers away from back door opening.**
- **Do not let children operate the back door.**

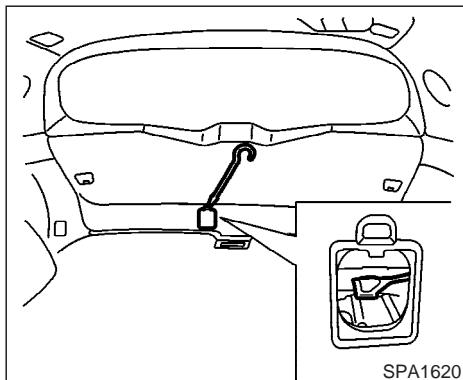

Back door release lever

If the back door cannot be opened with the door lock switch due to a discharged battery, follow the these steps.

1. Remove the cover inside of the back door with a suitable tool.
2. Move the lever as illustrated to open the door.

Contact your INFINITI dealer as soon as possible for repair.



WARNING

- **Always check to be sure the back door has been closed securely to prevent it from opening while driving.**
- **Do not drive with the back door open. This could allow dangerous exhaust gases to be drawn into the vehicle.**

FUEL FILLER LID

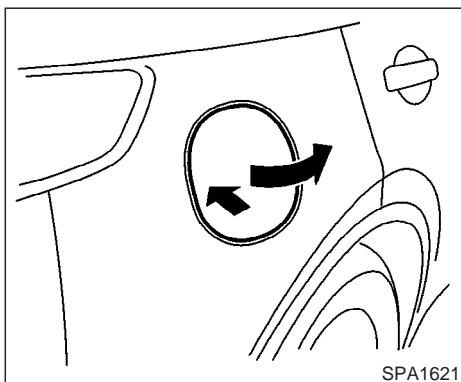

- Press the power door lock switch to the unlock side.

To lock, close the fuel filler lid and lock the doors.

OPEN THE FILLER LID

To open the fuel filler lid, unlock it using one of the following operations, then push the left-hand side of the lid.

- Press the unlock button on the keyfob or Intelligent Key twice.
- Press the driver's door handle request switch once.
- Insert the metal key into the door lock cylinder and turn the door key clockwise twice.

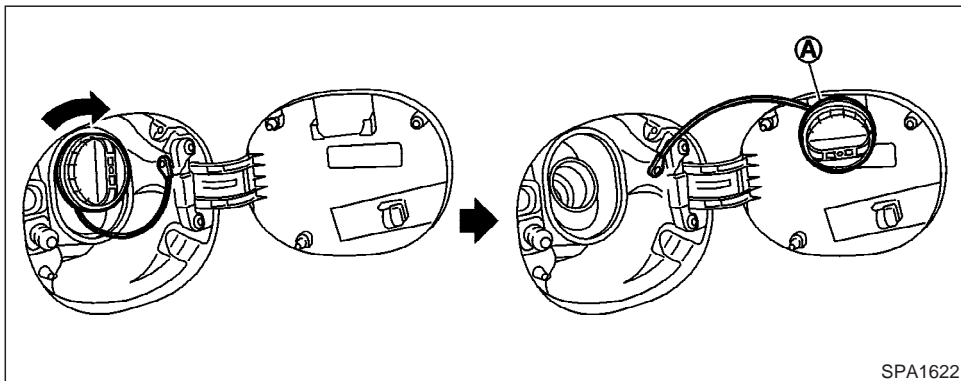

FUEL FILLER CAP

The fuel filler cap is a ratcheting type. Tighten the cap clockwise until ratcheting clicks are heard.

Put the fuel filler cap (A) on the cap holder while refueling.



WARNING

- Gasoline is extremely flammable and highly explosive under certain conditions. You could be burned or seri-

ously injured if it is misused or mishandled. Always stop the engine and do not smoke or allow open flames or sparks near the vehicle when refueling.

- Fuel may be under pressure. Turn the cap a third of a turn, and wait for any hissing sound to stop to prevent fuel from spraying out and possible personal injury. Then remove the cap.
- Do not attempt to top off the fuel tank

after the fuel pump nozzle shuts off automatically. Continued refueling may cause fuel overflow, resulting in fuel spray and possibly a fire.

- Use only an original equipment type fuel filler cap as a replacement. It has a built-in safety valve needed for proper operation of the fuel system and emission control system. An incorrect cap can result in a serious malfunction and possible injury. It could also cause the malfunction indicator lamp to come on.
- Never pour fuel into the throttle body to attempt to start your vehicle.
- Do not fill a portable fuel container in the vehicle or trailer. Static electricity can cause an explosion of flammable liquid, vapor or gas in any vehicle or trailer. To reduce the risk of serious injury or death when filling portable fuel containers:
 - Always place the container on the ground when filling.

SERVICE
ENGINE
SOON

- Do not use electronic devices while filling.
- Keep the pump nozzle in contact with the container while you are filling it.
- Use only approved portable fuel containers for flammable liquid.



CAUTION

- If fuel is spilled on the car body, flush it away with water to avoid paint damage.
- Tighten until the fuel filler cap clicks. Failure to tighten the fuel filler cap properly may cause the malfunction indicator lamp (MIL) to illuminate. If the lamp illuminates because the fuel filler cap is loose or missing, tighten or install the cap and continue to drive the vehicle. The lamp should turn off after a few driving trips. If the lamp does not turn off after a few driving trips, have the vehicle inspected by an au-

thorized INFINITI dealer.

- For additional information, see the “Malfunction indicator lamp (MIL)” in the “2. Instruments and controls” section.

TILTING TELESCOPIC STEERING COLUMN

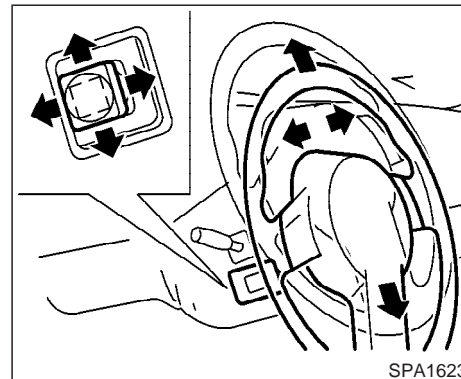

AUTOMATIC OPERATION



WARNING

Do not adjust the steering wheel while driving. You could lose control of your vehicle and cause an accident.

Tilt operation

Push the lever to adjust the steering wheel up or down to the desired position.

Jump up operation

The automatic drive positioner system will make the steering wheel jump up automatically. This lets the driver get into and out of the seat more easily.

Telescopic operation

Push the lever to adjust the steering wheel forward or backward to the desired position.

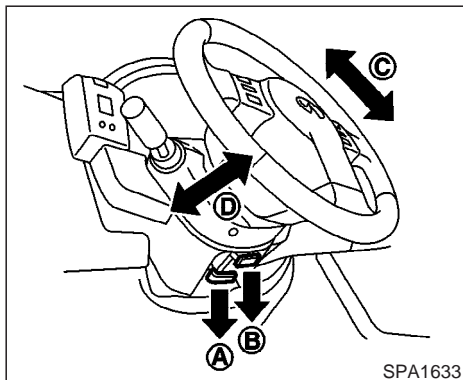

Telescopic operation

Push the lever (B) to adjust the steering wheel forward or backward to the desired position (D).

MANUAL OPERATION



WARNING

Do not adjust the steering wheel while driving. You could lose control of your vehicle and cause an accident.

Tilt operation

Push the lever (A) to adjust the steering wheel up or down to the desired position (C).

SUN VISORS

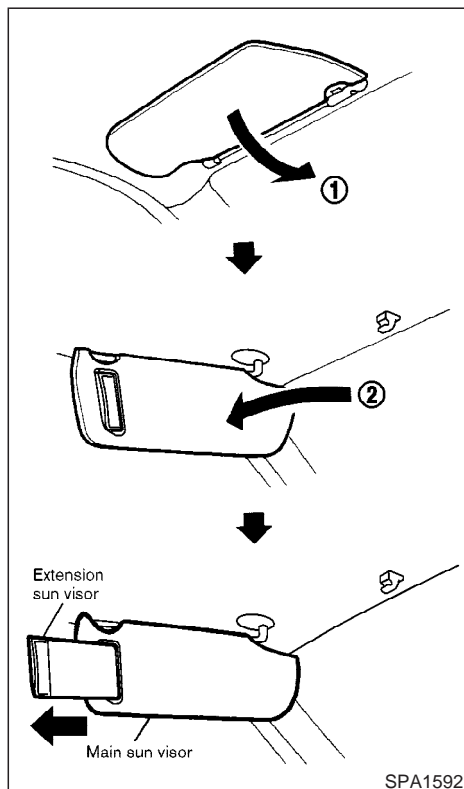

CAUTION

- Store the main sun visor after storing the extension sun visor and sub-sun visor.
- Do not pull the extension sun visor forcibly downward.

1. To block out glare from the front, swing down the main sun visor.
2. To block glare from the side, remove the main sun visor from the center mount and swing it to the side.
3. Draw out the extension sun visor to block from farther glare.

MIRRORS

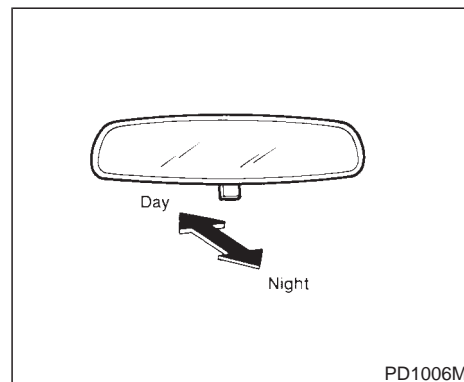

INSIDE MIRROR

The night position will reduce glare from the headlights of vehicles behind you at night.

WARNING

Use the night position only when necessary, because it reduces rear view clarity.

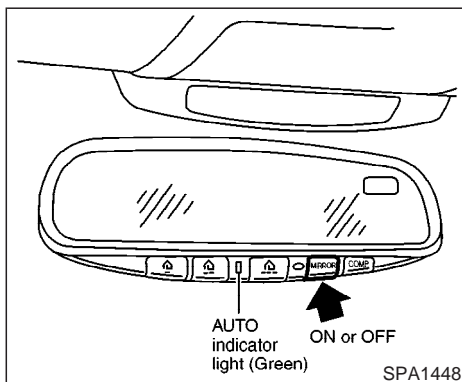

When the inside MIRROR switch is in the ON position (The Auto indicator light will illuminate), excessive glare from the headlights of the vehicle behind you will be reduced. When the switch of the inside mirror is in the OFF position, the inside mirror will operate normally.

For the HomeLink[®] Universal Transceiver and the compass display, see the description in the “2. Instruments and controls” section.

AUTOMATIC ANTI-GLARE INSIDE MIRROR (if so equipped)

WARNING

Use Automatic Anti-glare only when necessary, because it reduces rear view clarity.

The inside mirror is designed so that it automatically changes reflection according to the intensity of the headlights of the vehicle following you.

3-32 Pre-driving checks and adjustments

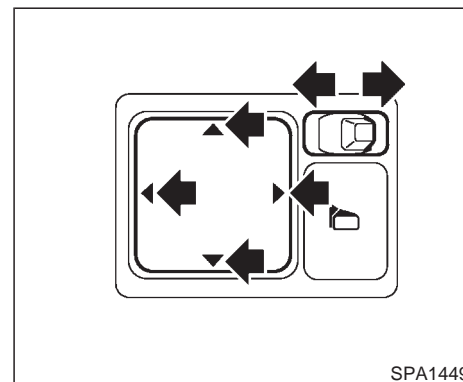

OUTSIDE MIRRORS

WARNING

Objects viewed in the outside mirror on the passenger side are closer than they appear. Be careful when moving to the right. Using only this mirror could cause an accident. Use inside mirror or glance over your shoulder to properly judge distances to other objects.

The outside mirror will operate only when the

ignition switch is in the ACC or ON position.

Move the switch to right or left to select the right or left outside mirror, then adjust.

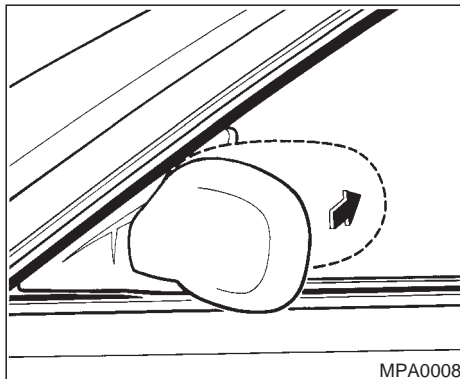

Foldable outside mirrors

Fold the outside mirrors by pushing them towards the rear of the vehicle.

AUTOMATIC DRIVE POSITIONER (if so equipped)

The automatic drive positioner system has two features:

- Memory storage function
- Entry/exit function

MEMORY STORAGE FUNCTION

Two positions for the driver's seat, steering column, and outside mirrors can be stored in the automatic drive positioner memory. Follow these procedures to use the memory system.

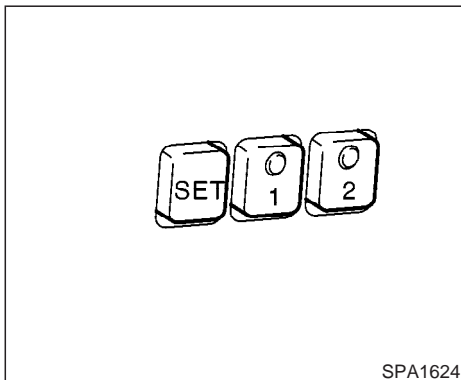

1. Apply the parking brake, and set the selector lever to the P (Park) position.
2. Turn the ignition ON.
3. Adjust the driver's seat, steering column and outside mirrors to the desired positions by manually operating each adjusting switch. For additional information, see "seats" in the "Safety — Seats, seat belts and supplemental air bags" section and "Steering wheel" and "Outside mirrors" earlier in this section.
During this step, do not turn the ignition to any positions other than ON.

3-34 Pre-driving checks and adjustments

4. Push the SET switch and, within 5 seconds, push the memory switch (1 or 2) fully for at least 1 second.

The indicator light for the pushed memory switch will come on and stay on for approximately 5 seconds after pushing the switch. After the indicator light goes off, the selected positions are stored in the selected memory (1 or 2).

If a new memory is stored in the same memory switch, the previous memory will be deleted.

Linking a keyfob or Intelligent Key to a stored memory position

A keyfob or Intelligent Key can be linked to a stored memory position with the following procedure.

1. Follow the steps for storing a memory position.
2. While the indicator light for the memory switch being set is illuminated for 5 seconds, press the  button on the keyfob or Intelligent Key. The indicator light will blink. After the indicator light goes off, the keyfob or Intelligent Key is linked to that memory setting.

With the key removed from the ignition switch, press the  button on the keyfob or Intelli-

gent Key. The driver's seat, steering wheel and outside mirrors will move to the memorized position.

Confirming memory storage

- Turn the ignition ON and push the SET switch. If the main memory has not been stored, the indicator light will come on for approximately 0.5 seconds. When the memory has stored the position, the indicator light will stay on for approximately 5 seconds.
- If the battery cable is disconnected, or if the fuse opens, the memory will be canceled. In such a case, reset the desired positions using the following procedures.

1. Open and close the driver's door more than two times with the ignition key in the LOCK position.
2. Reset the desired position using the previous procedure.

Selecting the memorized position

1. Set the selector lever to the P (Park) position.
2. Turn the ignition ON.
3. Push the memory switch (1 or 2) fully for at least 1 second.

The driver's seat, steering column and outside mirrors will move to the memorized position with the indicator light flashing, and then the light will stay on for approximately 5 seconds.

ENTRY/EXIT FUNCTION

This system is designed so that the driver's seat, steering column and door mirrors will automatically move when the automatic transmission selector lever is in the P (Park) position. This allows the driver to get into and out of the driver's seat more easily.

The driver's seat will slide backward and the steering wheel will move up:

- When the driver's door is opened after removing the key from the ignition switch or the ignition knob (if so equipped), or returning the ignition knob to lock position.
- When the driver's door is opened with the key turned to LOCK.
- When the key is turned from ACC to LOCK or returning the ignition knob to lock position with the driver's door open.

The driver's seat and steering wheel will return to the previous position:

- When the key is inserted into the ignition switch or the ignition knob (if so equipped) is pushed in after closing the door.

- When the driver's door is closed with the key turned to LOCK.
- When the key or the ignition knob is turned from ACC to ON with the driver's door open.

The entry/exit feature can be adjusted or canceled. See "Vehicle electronic systems" in the "4. Display screen, heater, air conditioner and audio systems" section of this manual.

System operation

The automatic drive positioner system will not work or will stop operating under the following conditions:

- when the vehicle speed is above 4 MPH (7 km/h).
- when any two or more of the memory switches are simultaneously pushed while the automatic drive positioner is operating.
- when the adjusting switch for the driver's seat is turned on while the automatic drive positioner is operating.
- when the memory switch 1 or 2 is not pushed for at least 1 second.
- when the seat has been already moved to the memorized position.

- when no seat position is stored in the memory switch.

The automatic drive positioner system can be adjusted and canceled. See "Automatic seat slide in getting off" and "Lift steering column when exiting vehicle" in the "4. Display screen, heater, air conditioner and audio systems" section.

4 Display screen, heater, air conditioner and audio systems

Safety note	4-2	Adjusting the screen	4-16
Control panel buttons — without navigation system	4-2	Operating tips	4-16
Name of components	4-3	Ventilators	4-16
How to use joystick and “ENTER” button	4-3	Heater and air conditioner (automatic)	4-18
How to use “PREV” button	4-3	Automatic operation	4-19
How to use “DISP” brightness control button	4-3	Manual operation	4-20
“DAY/NIGHT” button	4-3	Operating tips	4-20
How to use “SETTING” button	4-3	In-cabin microfilter (if so equipped)	4-21
How to use “MAINT” (maintenance) button	4-5	Servicing air conditioner	4-21
How to use “TRIP” button	4-6	Audio system	4-22
How to use “FUEL ECON” button	4-6	FM radio reception	4-22
How to use “E/M” button	4-7	AM radio reception	4-23
Outside air temperature	4-7	Satellite radio reception	4-23
Control panel buttons — with navigation system	4-7	Audio operation precautions	4-23
Name of components	4-8	FM-AM-SAT radio with cassette player and compact disc (CD) changer	4-26
How to use joystick and “ENTER” button	4-8	CD care and cleaning	4-32
How to use “PREV” button	4-8	Steering switch for audio control (if so equipped)	4-33
Setting up start-up screen	4-8	INFINITI mobile entertainment system (MES) (if so equipped)	4-34
How to use “SETTING” button	4-9	Digital video disc (DVD) player controls	4-35
“DAY/NIGHT” button	4-12	Remote control	4-35
How to use the “TRIP” button	4-12	Remote control holder	4-36
Rearview monitor (if so equipped)	4-15		
How to read the displayed lines	4-15		

Flip-down screen	4-36
Playing a digital video disc.....	4-37
Care and maintenance.....	4-40

How to handle the DVD	4-41
Antenna	4-43
Car phone or CB radio	4-43

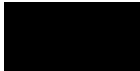

SAFETY NOTE



WARNING

- Positioning of the heating or air conditioning controls and display controls should not be done while driving, so that full attention may be given to vehicle operation.
- Do not disassemble or modify this system. If you do, it may result in accidents, fire, or electrical shock.
- Do not use this system if you notice any abnormality, such as a frozen screen or lack of sound. Continued use of the system may result in an accident, fire or electric shock.
- In case you notice any foreign objects in the system hardware, spill liquid on it, or notice smoke or smell coming from it, stop using the system immediately and contact your nearest INFINITI dealer. Ignoring such conditions may lead to an accident, fire, or electric shock.

CONTROL PANEL BUTTONS — WITHOUT NAVIGATION SYSTEM

Model without Navigation system

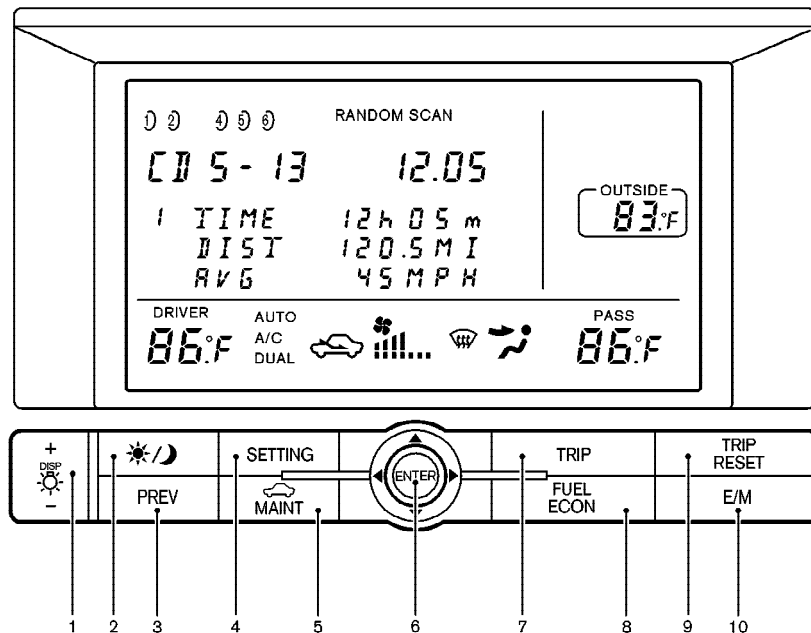

SAA0715

When you use this system, make sure the engine is running.

If you use the system with the engine not running (ignition ON or ACC) for a long time, it will use up all the battery power, and the engine will not start.

Reference symbols:

“ENTER” button

This is a button on the control panel.

“Display” key

This is a select key on the screen. By selecting this key you can proceed to the next function.

NAME OF COMPONENTS

1. “DISP” brightness control button; refer to the right column.
2. “DAY/NIGHT” brightness control button; refer to page 4-3.
3. “PREV” previous button; refer to page 4-3.
4. “SETTING” button; refer to page 4-3.
5. “MAINT” maintenance button; refer to page 4-5.
6. Joystick and “ENTER” push button; refer to page 4-3.

7. “TRIP” drive computer button; refer to page 4-6.

8. “FUEL ECON” button; refer to page 4-6.

9. “TRIP RESET” button; refer to page 4-6.

10. “E/M” button; refer to page 4-7.

To turn off the screen, push the “DAY/NIGHT” button for more than approximately 1.5 seconds. The screen will change to “CONFIRM DISPLAY OFF YES or NO”.

HOW TO USE JOYSTICK AND “ENTER” BUTTON

Choose an item on the display using the joystick. Push the **“ENTER”** button only when the use of it is instructed on the display.

HOW TO USE “PREV” BUTTON

Finish setup:

If you touch **“PREV”** button after the setup is completed, the setup will start over.

HOW TO USE “DISP” BRIGHTNESS CONTROL BUTTON

The display brightness control operates when the ignition switch is in the ACC or ON position. To brighten the display, push the “+” side

of the button. To darken the display, push the “-” side of the button.

“DAY/NIGHT” BUTTON

To change the display brightness, push the “DAY/NIGHT” button. Pushing the button again will change the display to DAY or NIGHT display. Then, adjust the brightness pushing the brightness control button.

If no operation is done within 10 seconds, or if the “PREV” button is pushed, the display will return to the previous display.

HOW TO USE “SETTING” BUTTON

Pushing the “SETTING” button will change the settings menu as follows:

- ① DISPLAY ON/OFF
- ② LANGUAGE
- ③ BEEP SET
- ④ SERVICE ALERT
- ⑤ PERSONALIZED SETTINGS MENU

Display ON/OFF

To turn off the screen, select the OFF key of the “Display ON/OFF” using the joystick.

The screen will change to “CONFIRM DISPLAY OFF YES or NO”.

If YES key is selected using the joystick, the screen will turn off after 2 beep sound and approximately 1 second.

To turn on the screen, push any button of CONTROL PANEL, air conditioner (except rear window defroster button) or audio button.

Language

The language can be changed to “English” or “Français” using the joystick.

Beep set

If the beep set “OFF” key is selected using the joystick, the beep sound will not operate. (except some caution beep sounds)

Service alert

If the service alert “ON” key is selected, the information will be displayed when the engine oil and the tire rotation reaches the preset driving distance.

Personalized setting menu

You can set the electronic systems as follows using the joystick.

Slide back DR seat when on exit (if so equipped):

The driver’s seat automatically moves back and returns to the original position for exceptional ease of exit and entry.

4-4 Display screen, heater, air conditioner and audio systems

Lift steering column on exit (if so equipped):

The steering column automatically tilts up and returns to the original position for exceptional ease of entry and exit.

Remote unlock door logic:

This key can switch the unlock doors of the 1st unlocking operation as follows:

Only the driver side door ←→ All the doors

Horn chirp with remote*:

This key changes the horn chirp mode occurring when pressing the LOCK button on the keyfob.

Lamps flash with remote*:

This key changes the hazard indicator flash mode occurring when pressing the LOCK or UNLOCK button on the keyfob.

* **If you change the horn chirp or the lamp flash with the keyfob or the Intelligent Key, the mode may not be changed with the display. Use the keyfob or the Intelligent Key to return the mode.**

Auto re-lock time:

The length of auto door re-lock time can be set. Select the “**Auto Re-Lock time**” key, then

move the joystick to adjust the time.

Auto headlamp sensitivity (if so equipped):

Automatic light illumination can be set as desired.

Select the “**Sensitivity of Automatic Headlights**” key, then move the joystick to the left (lower) or right (higher).

Auto headlamp off delay (if so equipped):

You can control how long it takes the automatic turn off timer to extinguish the headlights in AUTO position.

Select the “**Automatic Headlamp Off Delay**” key, then move the joystick to the left or right to adjust the timer.

Speed sensing wiper interval:

This key turns on and off the driving speed dependent intermittent wiper function.

Confirm reset settings:

To display the “Confirm Reset Settings”, push the “Reset All Settings” key.

When this key is selected and turned on using the “ENTER” button, all settings made by PERSONALIZED SETTINGS will return to the initial conditions.

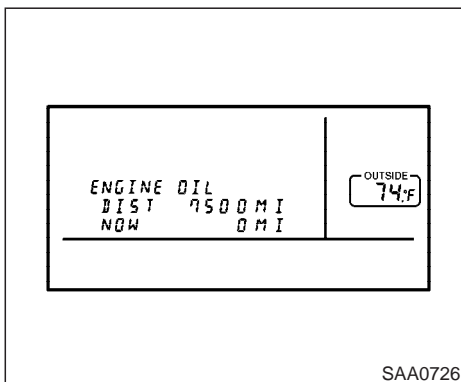

HOW TO USE “MAINT” (Maintenance) BUTTON

Pushing the “MAINT” button will change the maintenance menu as follows:

ENGINE OIL → TIRE ROTATION → TIRE PRESSURE (if so equipped)

To reset the driving distance, push the “MAINT” button or “TRIP RESET” button for more than approximately 1.5 seconds.

To set the distance, push the joystick to left or right.

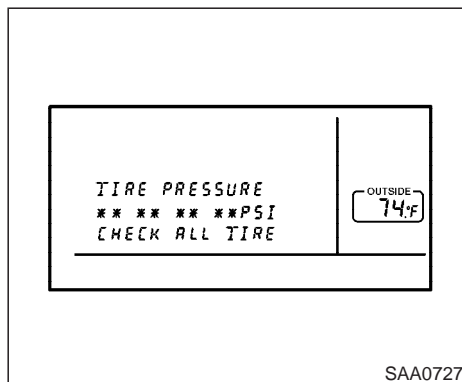

Tire pressure information (if so equipped)

Pressure indication in ** psi on the screen indicates that the pressure is being measured. After a few driving trips, the pressure for each tire will be displayed randomly.

The order of tire pressure figures displayed on the screen does not correspond with the actual order of the tire position.

Tire pressure rises and falls depending on the heat caused by the vehicle's traveling condition and the temperature.

In case of low tire pressure, a message (FLAT

TIRE or CHECK ALL TIRE) is displayed on the screen:

FLAT TIRE — very low tire air pressure.



WARNING

When a spare tire is mounted or a wheel is replaced, the pressure of that tire will not be indicated and not be monitored by the low tire pressure warning system. Contact your INFINITI dealer as soon as possible for tire replacement and/or system resetting.

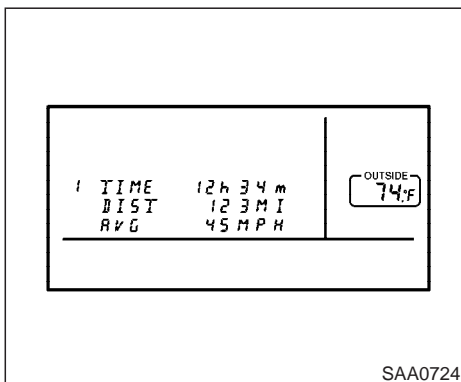

HOW TO USE “TRIP” BUTTON

When the “TRIP” button is pushed, the following modes will display on the screen.

TRIP 1 (TIME, DIST, AVG) → TRIP 2 (TIME, DIST, AVG) → OFF

You can set the two kinds of journey time (TIME — max 99 hours 59 minutes), trip odometer (DIST — mile or km) and average speed (AVG — MPH or km/h).

To reset the TRIP 1 or TRIP 2, push the “TRIP” button or the “TRIP RESET” button for more than approximately 1.5 seconds.

4-6 Display screen, heater, air conditioner and audio systems

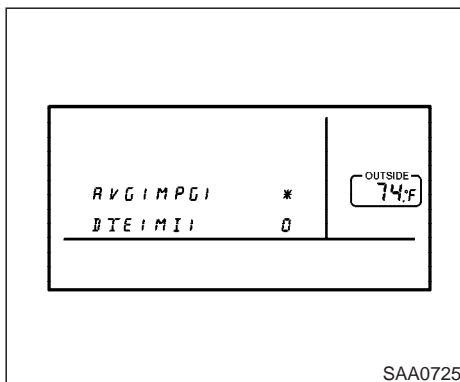

HOW TO USE “FUEL ECON” BUTTON

The average fuel consumption (MPG or L/100 km) and the distance to empty (dte — MI or km) will appear on the screen when the “FUEL ECON” button is pushed.

Average fuel consumption (Mpg or L/100 km)

The average fuel consumption mode shows the average fuel consumption since the last reset. Resetting is done by pressing the “TRIP RESET” or “FUEL ECON” button for more than approximately 1.5 seconds.

The display is updated every 30 seconds. At about the first 30 seconds and 1/3 miles (500 m) after a reset or connecting battery cable, the display will show (----).

Distance to empty (dte — mile or km)

The distance to empty (dte) mode provides you with an estimation of the distance that can be driven before refueling. The dte is constantly being calculated, based on the amount of fuel in the fuel tank and the actual fuel consumption.

The display is updated every 30 seconds.

When the fuel level drops even lower, the dte display will change to (*).

NOTE:

- If the amount of fuel added while the ignition switch is OFF is small, the display just before the ignition switch is turned OFF may continue to be displayed.
- When driving uphill or rounding curves, the fuel in the tank shifts, which may momentarily change the display.

CONTROL PANEL BUTTONS — WITH NAVIGATION SYSTEM

HOW TO USE “E/M” BUTTON

You can change the unit as follows using the “E/M” (English/Metric) button.

Unit: US — Mile, °F, MPG

Metric — km, °C, L/100 km

OUTSIDE AIR TEMPERATURE

The outside air temperature is displayed in °F or °C.

It may differ from the actual outside air temperature due to the sensor location.

Model with Navigation system

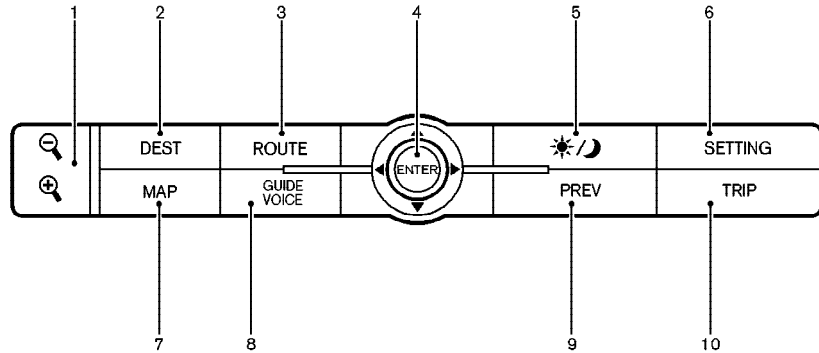

SAA0712

When you use this system, make sure the engine is running.

If you use the system with the engine not running (ignition ON or ACC) for a long time, it will use up all the battery power, and the engine will not start.

Reference symbols:

“ENTER” button

This is a button on the control panel.

“Display” key

This is a select key on the screen. By selecting this key you can proceed to the next function.

NAME OF COMPONENTS

1., 2., 3., 7. and 8

For Navigation system control buttons; refer to the separate Navigation Owner’s Manual.

4. Joystick and “ENTER” push button; refer to page 4-8.
5. “DAY/NIGHT” brightness control button; refer to page 4-12.
6. “SETTING” button; refer to page 4-9.
9. “PREV” previous button; refer to page 4-8.

4-8 Display screen, heater, air conditioner and audio systems

10. “TRIP” drive computer button; refer to page 4-12.

HOW TO USE JOYSTICK AND “ENTER” BUTTON

Choose an item on the display using the joystick and push the “ENTER” button for operation.

HOW TO USE “PREV” BUTTON

This has two functions.

- Go back to the previous display (cancel).

If you touch “PREV” button during setup, the setup will be canceled and/or the display will return to the previous screen.

- Finish setup.

If you touch this button after the setup is completed, the setup will start over, and the display will return to the climate control or Audio mode, and Navigation screen.

SETTING UP START-UP SCREEN

When you turn the ignition switch to ACC, the SYSTEM START-UP warning is displayed on the screen. Read the warning and select the “I AGREE” (English) or “ENTER” (Français) key then push the “ENTER” button.

If you do not push the “ENTER” button, this system will not proceed to the next step display.

If you do not touch the button or screen key for more than 1 minute on the TRIP, SETTING or START-UP screen, the screen will change to TRIP screen automatically.

To proceed to the next step, refer to the separate Navigation system Owner’s Manual.

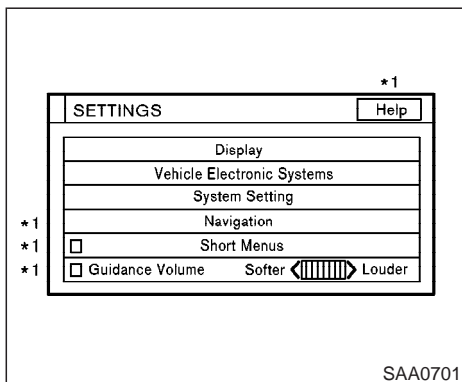

For models with navigation system:

*1 — Please refer to the separate Navigation system Owner's Manual.

HOW TO USE "SETTING" BUTTON

The SETTING screen will appear when the "SETTING" button is pushed.

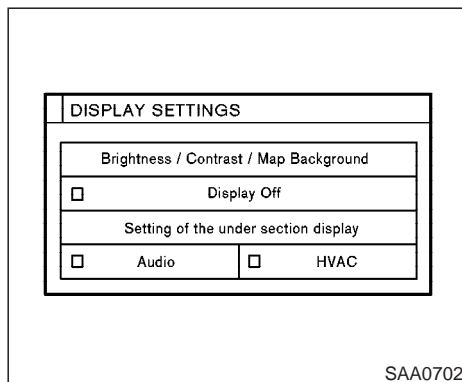

"DISPLAY" settings

The DISPLAY SETTINGS screen will appear when pushing the "SETTING" button, selecting "Display" key and pushing the "ENTER" button.

Brightness/Contrast/Map Background:

To adjust the brightness and contrast of the screen, select the "Brightness/contrast" key and push the "ENTER" button. Then you can adjust the brightness to Darker or Brighter, the contrast to Lower or Higher using the joystick.

The Map Background is for models with navigation system. Please refer to the separate

navigation system Owner's Manual.

Display Off:

To turn off the screen, push the "SETTING" button and select the "Display" key and "Display Off" key. The indicator of the "Display Off" will turn on to amber. When any mode button is pushed with the screen off, the screen turns on for further operation. The screen will turn off automatically 5 seconds after the operation is finished on the map display in the Audio, HVAC (Heater and air conditioner), SETTING or VEHICLE INFO. modes.

To turn on the screen, push the "SETTING" button and select the "Display" key and "Display Off" key, then set the screen to on by pushing the "ENTER" button.

Setting Audio or HVAC display:

Choose the "Audio" or "HVAC" (Heater and air conditioner) key to be displayed at the bottom, by using the joystick. The audio or HVAC (heater, air conditioner) setting condition will normally appear on the screen.

To return to the setting screen, push the "SETTING" button or "PREV" button.

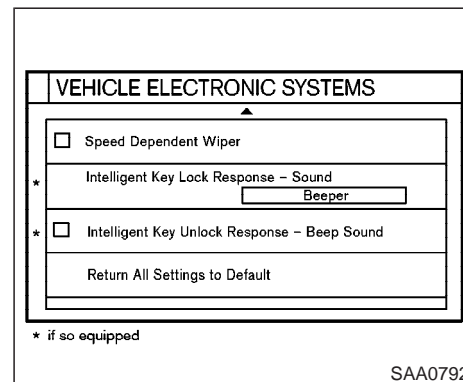
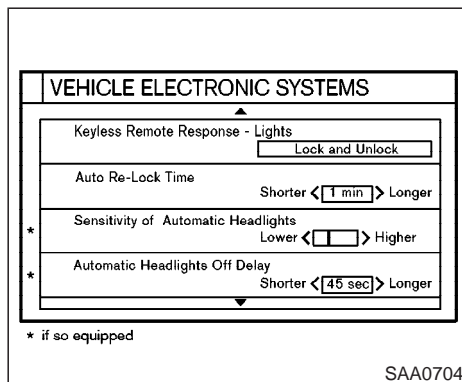
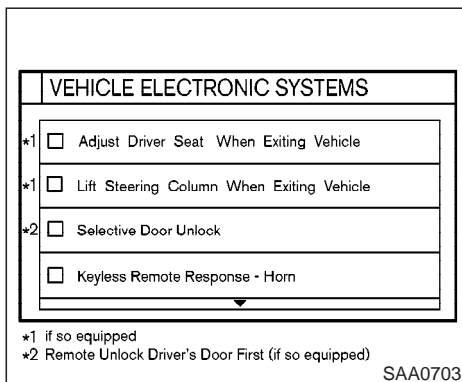

Vehicle electronic systems

You can only get this menu if the ignition switch is ON. If the ignition switch or ignition knob is set to ACC, you will not get this menu to come up.

The VEHICLE ELECTRONIC SYSTEMS screen will appear when selecting the “Vehicle Electronic Systems” key with the joystick and pushing the “ENTER” button.

You can set the various electronic systems operating conditions.

To set an operating condition, select the appli-

cable item using the joystick, and push the “ENTER” button.

The indicator light alternately turns on and off each time the “ENTER” button is pressed.

Indicator light is illuminated. — ON
Indicator light is not illuminated. — OFF

Adjust driver seat when exiting vehicle (if so equipped):

The driver’s seat automatically moves back and returns to the original position for exceptional ease of exit and entry.

Lift steering column when exiting vehicle (if so equipped):

The steering column automatically tilts up and returns to the original position for exceptional ease of entry and exit.

Selective door unlock (if Intelligent Key is equipped)/Remote unlock driver’s door first:

This key can switch the unlock doors of the 1st unlocking operation as follows:

ON (Only the driver side door) ↔ OFF (All the doors)

ON (Only the request switch pressed door)
←→ OFF (All the doors)

Keyless remote response — Horn*:

This key changes the horn chirp mode occurring when pressing the LOCK button on the Intelligent Key or keyfob.

Keyless remote response — Lights*:

*** If you change the horn chirp or the lamp flash with the keyfob or the Intelligent Key, the mode may not be changed with the display. Use the keyfob or the Intelligent Key to return the mode.**

This key changes the hazard indicator flash mode occurring when pressing the LOCK or UNLOCK button on the Intelligent Key or keyfob.

Auto re-lock time:

The length of auto door re-lock time can be set. Select the **"Auto Re-Lock time"** key, then move the joystick and push the ENTER button to adjust the time.

Sensitivity of automatic headlights (if so equipped):

Automatic light illumination can be set as desired.

Select the **"Sensitivity of Automatic Head-**

lights" key, then move the joystick to the left (lower) or right (higher).

Automatic headlights off delay (if so equipped):

You can control how long it takes the automatic turn off timer to extinguish the headlights in AUTO position.

Select the **"Automatic Headlights Off Delay"** key, then move the joystick to the left or right to adjust the timer.

Speed dependent wiper:

This key turns on and off the driving speed dependent intermittent wiper function.

Intelligent Key lock response — Sound (if so equipped):

The sound pattern of the Intelligent request switch operation can be set as desired. Select the **"Intelligent Key lock response — Sound"** key, then push the ENTER button to change the sound pattern.

Intelligent Key unlock response — Sound (if so equipped):

The beep sounds when unlocking door with the Intelligent request switch can be turned on or off.

Return all settings to default:

When this key is selected and turned on using the "ENTER" button, all settings made by VEHICLE ELECTRONIC SYSTEMS will return to the initial conditions.

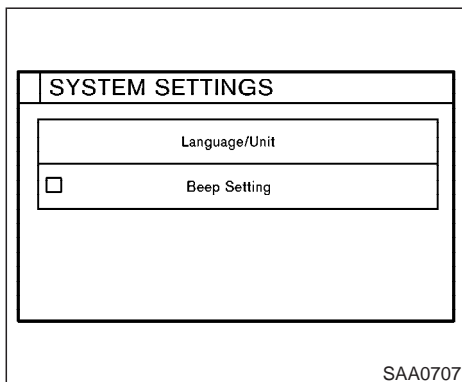

System settings

Language/Unit:

The LANGUAGE/UNIT screen will appear when selecting the “Language/Unit” key and pushing the “ENTER” button.

Language: English or French

Unit: US — Mile, °F, MPG
Metric — km, °C, L/100 km

You can select the language and unit using the joystick and “ENTER” button.

Beep setting:

When Beep setting is on (indicator light on), a beep will sound if the any audio button is pushed.

“DAY/NIGHT” BUTTON

To change the display brightness, push the “DAY/NIGHT” button. Pushing the button again will change the display to DAY or NIGHT display. Then, adjust the brightness moving the joystick right or left.

If no operation is done within 10 seconds, or if the “PREV” button is pushed, the display will return to the previous display.

HOW TO USE THE “TRIP” BUTTON

When the “TRIP” button is pushed, the following models will display on the screen.

Warning message (if there are any) → TRIP 1 (Elapsed Time, Driving Distance, Average Speed) → TRIP 2 (Elapsed Time, Driving Distance, Average Speed) → FUEL ECONOMY (Average Fuel Economy, Distance to Empty) → MAINTENANCE (Engine Oil, The Rotation and Tire Pressure — if so equipped) → OFF.

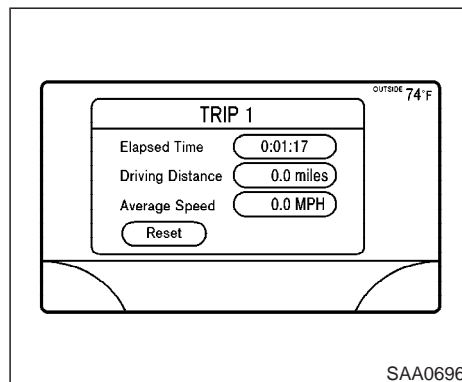

Trip 1, trip 2 and fuel economy items

To reset the TRIP 1, TRIP 2 and FUEL ECONOMY, select the “RESET” key using the joystick and push the “ENTER” button or push the “TRIP” button for more than approximately 1.5 seconds.

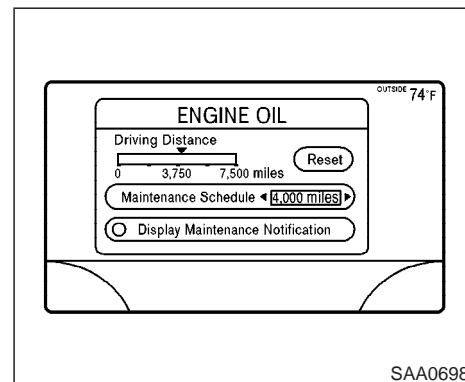
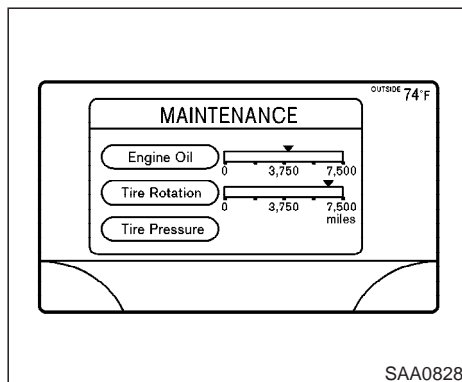
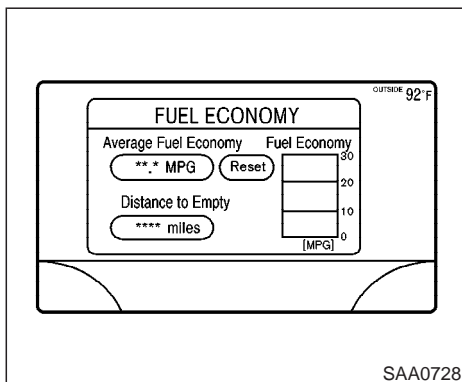

Maintenance items

You can set the engine oil and the tire rotation interval.

And the tire pressure will appear on the screen (if the tire pressure system is equipped).

To display the setting of the maintenance interval, select the "Engine Oil" or "Tire Rotation" key using the joystick and push the "ENTER" button.

To set the maintenance interval, select the "Maintenance Schedule" key by using the joystick and move the joystick to right or left.

To reset the maintenance interval, select the "RESET" key using the joystick and push the "ENTER" button.

To display the MAINTENANCE INFORMATION, automatically when setting trip distance is reached, select the "Display Maintenance Notification" key and push the "ENTER" button.

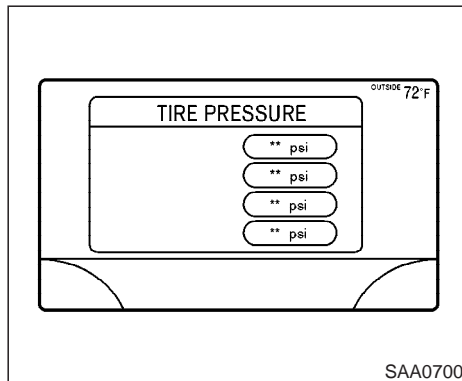
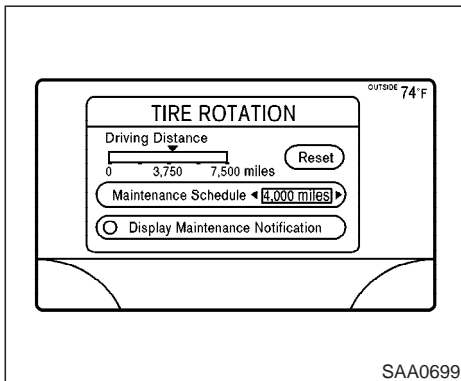

displayed on the screen:
 FLAT TIRE — low tire air pressure.



WARNING

When a spare tire is mounted or a wheel is replaced, the pressure of that tire will not be indicated and not be monitored by the low tire pressure warning system. Contact your INFINITI dealer as soon as possible for tire replacement and/or system resetting.

Tire pressure information (if so equipped)

Pressure indication in ** psi on the screen indicates that the pressure is being measured. After a few driving trips, the pressure for each tire will be displayed randomly.

The order of tire pressure figures displayed on the screen does not correspond with the actual order of the tire position.

Tire pressure rises and falls depending on the heat caused by the vehicle's traveling condition and the temperature.

In case of low tire pressure, a message is

REARVIEW MONITOR (if so equipped)

When the selector lever is shifted into the R (Reverse) position, the monitor display shows view to the rear of the vehicle.



CAUTION

- The rearview camera is a convenience but it is not a substitute for proper backing and should not be used for lane changes. Always turn and check that it is safe to do so before backing up or changing lanes. Always back up slowly.
- The system is designed as an aid to the driver in detecting large stationary objects to help avoid damaging the vehicle. The system will not detect small objects below the bumper and may not detect objects close to the bumper or on the ground.
- Objects viewed in the rearview monitor differ from actual distance because a wide-angle lens is used. Objects in the rearview monitor will appear visually opposite than when viewed in the rearview and outside mirrors.

- Make sure that the trunk is securely closed when backing up.
- Do not put anything on the rearview camera. The rearview camera is installed beside the license plate light.
- When washing the vehicle with high-pressure water, be sure not to spray it around the camera. Otherwise, water may enter the camera unit causing water condensation on the lens, a malfunction, fire or an electric shock.
- Do not strike the camera. It is a precision instrument. Otherwise, it may malfunction or cause damage resulting in a fire or an electric shock.
- Do not use alcohol, benzine or thinner to clean the camera. This will cause discoloration.
- There is a plastic cover over the camera. Do not scratch the cover when cleaning dirt or snow from the cover.

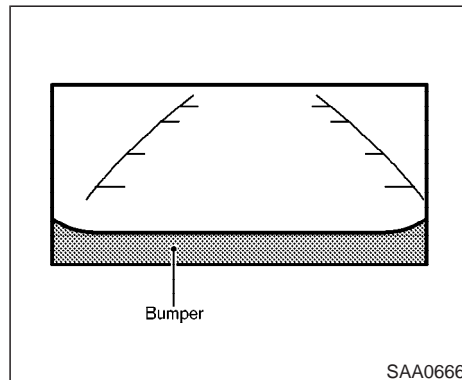

HOW TO READ THE DISPLAYED LINES

Lines which indicate the vehicle clearance and distances to objects with reference to the bumper line are displayed on the monitor.

They are indicated as reference distances to objects. Displayed lines indicate distances 1.5 feet (red), 3 feet (yellow), 7 feet (green) and 10 feet (green) [0.5 m (red), 1 m (yellow), 2 m (green) and 3 m (green)] from the lower part of the bumper line.

The vehicle clearance lines are wider than the actual clearance.

ADJUSTING THE SCREEN

To adjust the quality of the screen, refer to HOW TO USE THE “**SETTING**” BUTTON in this section.

- When it is difficult to see in the rearward direction due to shady conditions, press the “**ENTER**” button to make objects in the monitor brighter.
- To change the brightness, press the “**ENTER**” button again, turn the key switch OFF or shift the reverse and wait for 10 seconds.

OPERATING TIPS

- When the selector lever is shifted to R, the display screen automatically changes to the rear view monitor mode. However, the radio can be heard.
- It may take some time for the rear view monitor to display after the selector lever has been shifted to R. Objects may be distorted momentarily. When the selector lever is returned to a position other than R, it may take some time for the screen to change. Objects on the screen may be distorted until they are completely displayed.
- When the temperature is extremely high or low, the screen may not clearly display

objects. This is not a malfunction.

- When strong light directly enters the camera, objects may not be displayed clearly.
- Vertical lines may be seen in objects on the screen. This is due to strong reflected light from the bumper. This is not a malfunction.
- The screen may flicker under fluorescent light. This is not a malfunction.
- The colors of objects on the rear view monitor may differ somewhat from those of the actual object.
- When the contrast of objects is low at night, pushing the “**ENTER**” button may not change the brightness.
- Objects on the monitor may not be clear in a dark place or at night.
- If dirt, rain or snow attaches to the camera, the rear view monitor may not clearly display objects. Clean the camera.
- To clean the camera, wipe with a cloth dampened with diluted mild cleaning agent and then wipe with a dry cloth.
- Do not use body wax on the camera window. Wipe off the wax with a clean cloth dampened with mild detergent diluted with water.

VENTILATORS

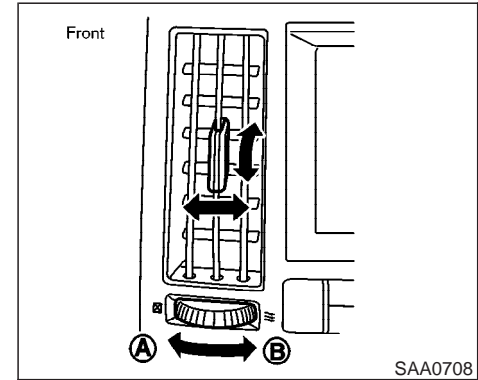

Open or close, and adjust the air flow direction of ventilators.

Ⓐ: This symbol indicates that the vents are closed when the vent switch is moved to the left.

Ⓑ: This symbol indicates that the vents are open when the vent switch is moved to the right.

Rear - Side

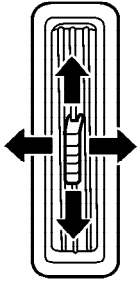

SAA0709

HEATER AND AIR CONDITIONER (Automatic)

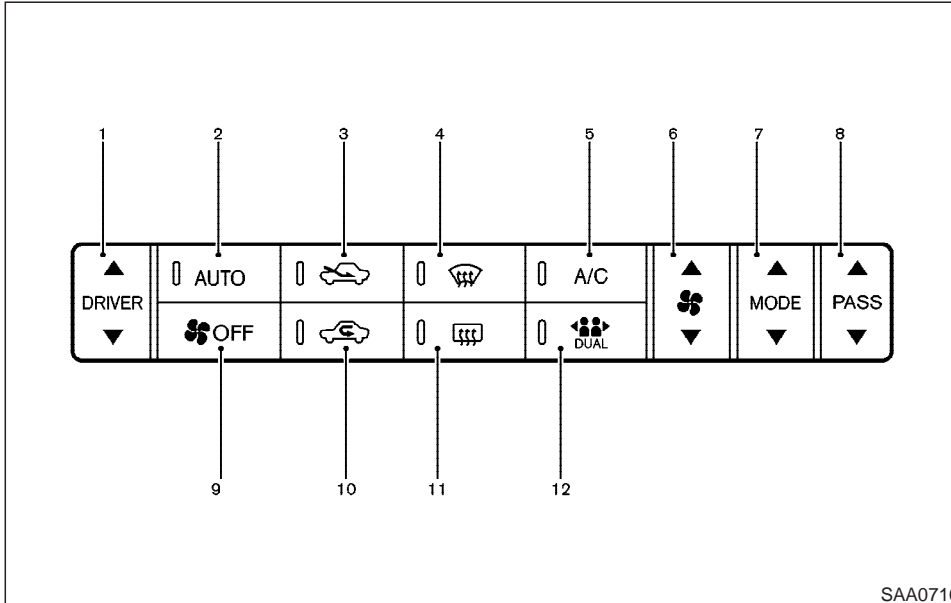

1. Temperature control button (driver only, or driver and passenger)
2. "AUTO" climate control ON button
3. "Air Fresh" button
4. "Front Defroster" button
5. "A/C" air conditioner ON/OFF button
6. Fan speed control button
7. "MODE" manual air flow control button

8. Temperature control button (passenger side)
9. "OFF" button for climate control system
10. "Air Recirculation" button
11. "Rear Window Defroster" button; refer to the "2. Instrument and controls" section.
12. "DUAL" passenger side temperature control ON/OFF button



WARNING

- **The air conditioner cooling function operates only when the engine is running.**
- **Do not leave children or adults who would normally require the support of others alone in your vehicle. Pets should not be left alone either. On hot, sunny days, temperatures in a closed vehicle could quickly become high enough to cause severe or possibly fatal injuries to people or animals.**
- **Do not use the recirculation mode for long periods as it may cause the interior air to become stale and the windows to fog up.**
- **Positioning of the heating or air conditioning controls should not be done while driving, so full attention may be given to vehicle operation.**

Start the engine and operate the controls to activate the air conditioner.

AUTOMATIC OPERATION

Cooling and/or dehumidified heating (AUTO)

This mode may be normally used all year round as the system automatically works to keep a constant temperature. Air flow distribution and fan speed are also controlled automatically.

1. Push the AUTO button on. (AUTO will be displayed.)
2. Push the temperature set button to set the desired temperature.
 - Adjust the temperature to about 75°F (24°C) for normal operation.
 - The temperature of the passenger compartment will be maintained automatically. Air flow distribution and fan speed are also controlled automatically.
3. You can individually set driver and front passenger side temperature using each temperature control button. When the DUAL button is pushed or passenger side temperature control button is turned, the DUAL indicator will come on. To turn off the passenger side temperature control, push the DUAL button.

Heating (A/C OFF)

The air conditioner does not activate. When you need to heat only, use this mode.

1. Push the A/C button. (A/C OFF will be displayed and A/C indicator will turn off.)
2. Turn the temperature set button to set the desired temperature.
 - The temperature of the passenger compartment will be maintained automatically. Air flow distribution and fan speed are also controlled automatically.
 - Do not set the temperature lower than the outside air temperature. Otherwise the system may not work properly.
 - Not recommended if windows fog up.

Dehumidified defrosting or defogging

1. Push the  FRONT defroster button on. (The indicator light on the button will come on.)
2. Push the temperature set button to set the desired temperature.
 - To quickly remove ice from the outside of the windows, push the fan speed control button ▲ and set to the maximum position.

- As soon as possible after the windshield is clean, push the AUTO button to return to the auto mode.
- When the  front defroster button is pushed, the air conditioner will automatically be turned on at outside temperatures above 23°F (-5°C) to defog the windshield, and the air recirculate mode will automatically be turned off.

Outside air is drawn into the passenger compartment to improve the defogging performance.



MANUAL OPERATION



Fan speed control

Push the fan control button  to manually control the fan speed.



Push the AUTO button to return to automatic control of the fan speed.

Air recirculation



Push the air recirculation button  to recirculate interior air inside the vehicle. The indicator light on the  button will come on.

The air recirculation  button cannot be activated when the air conditioner is in the front defrosting mode  .

Fresh air





Push the button  to draw outside air into the passenger compartment. The indicator light on the  button will come on.

Automatic intake air control

In the AUTO mode, the intake air will be controlled automatically. To manually control the intake air, push the air recirculate  or fresh air  button. To return to the automatic control mode, push the indicator-illuminated button for about 2 seconds. The indicator lights (both air recirculate and fresh air buttons) will flash twice, and then the intake air will be controlled automatically.

Air flow control

Pushing the MODE manual air flow control button selects the air outlet to:

-  : Air flows from center and side ventilators.
-  : Air flows from center and side ventilators and foot outlets.
-  : Air flows mainly from foot outlets.
-  : Air flows from defroster and foot outlets.

To turn the system off

Push the OFF button.

OPERATING TIPS

When the engine coolant temperature and outside air temperature are low, the air flow from the foot outlets may not operate for a maximum of 150 seconds. However, this is not a malfunction. After the coolant temperature warms up, the air flow from the foot outlets will operate normally.

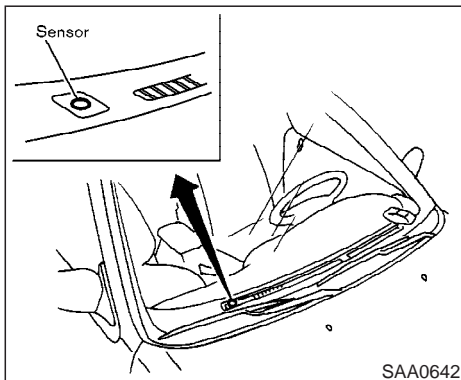

The sensor on the instrument panel helps maintain a constant temperature; do not put anything on or around this sensor.

IN-CABIN MICROFILTER (if so equipped)

The air conditioning system is equipped with an in-cabin microfilter which collects dirt, pollen, dust, etc. To make sure the air conditioner heats, defogs, and ventilates efficiently, replace the filter in accordance with the maintenance schedule in this manual. To replace the filter, contact your INFINITI dealer.

The filter should be replaced if the air flow

decreases significantly or if windows fog up easily when operating the heater or air conditioning system.

SERVICING AIR CONDITIONER

The air conditioning system in your INFINITI vehicle is charged with a refrigerant designed with the environment in mind. **This refrigerant will not harm the earth's ozone layer.** However, special charging equipment and lubricants are required when servicing your INFINITI air conditioner. Using improper refrigerants or lubricants will cause severe damage to your air conditioning system. See "Capacities and recommended fuel/lubricants" in the "9. Technical and consumer information" section for air conditioning system refrigerant and lubricant recommendations.

Your INFINITI dealer will be able to service your environmentally friendly air conditioning system.



WARNING

The air conditioner system contains refrigerant under high pressure. To avoid personal injury, any air conditioner service should be done only by an experienced technician with proper equipment.

AUDIO SYSTEM

Turn the ignition key to ACC or ON and press the power on switch to turn on the radio. If you listen to the radio with the engine not running, the key should be turned to the ACC position.

Radio reception is affected by station signal strength, distance from radio transmitter, buildings, bridges, mountains and other external influences. Intermittent changes in reception quality normally are caused by these external influences.

Using a cellular phone in or near the vehicle may influence radio reception quality.

Radio reception

Your radio system is equipped with state-of-the-art electronic circuits to enhance radio reception. These circuits are designed to extend reception range, and to enhance the quality of that reception.

However there are some general characteristics of FM, AM and satellite radio signals that can affect radio reception quality in a moving vehicle, even when the finest equipment is used. These characteristics are completely normal in a given reception area, and do not indicate any malfunction in your radio system.

Remember that a moving vehicle is not the ideal place to listen to a radio. Because of the movement, reception conditions will constantly

change. Buildings, terrain, signal distance and interference from other vehicles can work against ideal reception. Described below are some of the factors that can affect your radio reception.

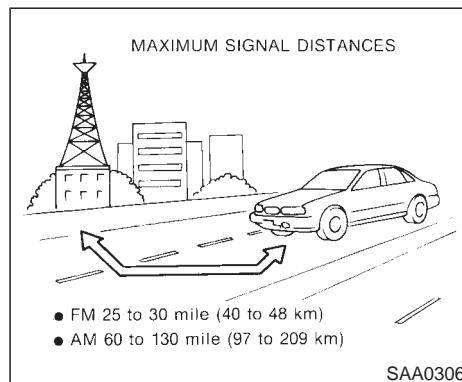

FM RADIO RECEPTION

Range: FM range is normally limited to 25 to 30 miles (40 to 48 km), with monaural (single channel) FM having slightly more range than stereo FM. External influences may sometimes interfere with FM station reception even if the FM station is within 25 miles (40 km). The strength of the FM signal is directly related to the distance between the transmitter and receiver. FM signals follow a line-of-sight path, exhibiting many of the same characteristics as light. For example they will reflect off objects.

Fade and drift: As your vehicle moves away

from a station transmitter, the signals will tend to fade and/or drift.

Static and flutter: During signal interference from buildings, large hills or due to antenna position, usually in conjunction with increased distance from the station transmitter, static or flutter can be heard. This can be reduced by adjusting the treble control counterclockwise to reduce treble response.

Multipath reception: Because of the reflective characteristics of FM signals, direct and reflected signals reach the receiver at the same time. The signals may cancel each other, resulting in momentary flutter or loss of sound.

AM RADIO RECEPTION

AM signals, because of their low frequency, can bend around objects and skip along the ground. In addition, the signals can be bounced off the ionosphere and bent back to earth. Because of these characteristics, AM signals are also subject to interference as they travel from transmitter to receiver.

Fading: Occurs while the vehicle is passing through freeway underpasses or in areas with many tall buildings. It can also occur for several seconds during ionospheric turbulence even in areas where no obstacles exist.

Static: Caused by thunderstorms, electrical

power lines, electric signs and even traffic lights.

SATELLITE RADIO RECEPTION

You must have a contract with a satellite radio provider to receive satellite radio programming.

When the satellite radio is first installed or the battery has been replaced, the satellite radio may not work properly. This is not a malfunction. Wait more than 10 minutes with satellite radio ON for satellite radio to receive all of the necessary data.

Satellite radio performance may be effected if cargo carried on the roof rack blocks the satellite radio signal.

If possible, do not put cargo over the satellite radio antenna.

AUDIO OPERATION PRECAUTIONS

Cassette player

- **To maintain good quality sound, INFINITI recommends using cassette tapes of 60 minutes or shorter in length.**
- **Cassette tapes should be removed from the player when not in use. Store cas-**

ettes in their protective cases and away from direct sunlight, heat, dust, moisture and magnetic sources.

- **Direct sunlight can cause the cassette to become deformed. The use of deformed cassettes may cause the cassette to jam in the player.**
- **Do not use cassettes with labels which are peeling and loose. If used, the label could jam in the player.**
- **If a cassette has loose tape, insert a pencil through one of the cassette hubs and rewind the tape firmly around the hubs. Loose tape may cause tape jamming and wavering sound quality.**
- **Over a period of time, the playback head, capstan and pinch roller may collect a tape coating residue as the tape is played. This residue accumulation can cause weak or wavering sound, and should be removed periodically with a head cleaning tape. If the residue is not removed periodically, the player may need to be disassembled for cleaning.**

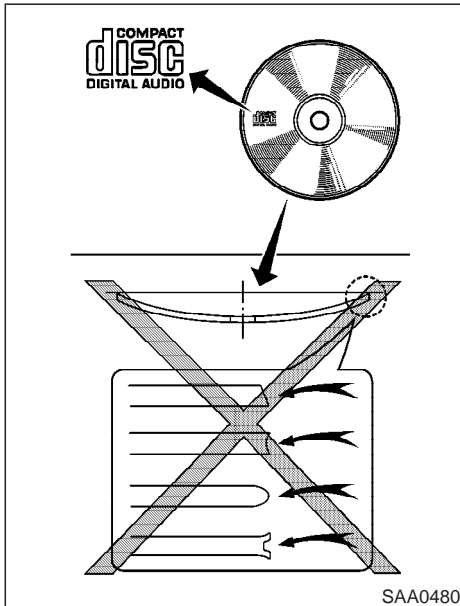

Compact Disc (CD) player

- Only use high quality 4.7 inches (12 cm) round discs that have the “COMPACT disc DIGITAL AUDIO” logo on the disc or packaging.

- During cold weather or rainy days, the player may malfunction due to the humidity. If this occurs, remove the CD and dehumidify or ventilate the player completely.
- The player may skip while driving on rough roads.
- The CD player sometimes cannot function when the compartment temperature is extremely high. Decrease the temperature before use.
- Do not expose the CD to direct sunlight.
- CDs that are of poor quality, dirty, scratched, covered with fingerprints, or that have pin holes may not work properly.
- The following CDs may not work properly:
 - Copy control compact discs (CCCD)
 - Recordable compact discs (CD-R)
 - Rewritable compact discs (CD-RW)
- Do not use the following CDs as they may cause the CD player to malfunction.
 - 3.1 in (8 cm) discs with an adapter
 - CDs that are not round

- CDs with a paper label
- CDs that are warped, scratched, or have abnormal edges

FM-AM-SAT RADIO WITH CASSETTE PLAYER
AND COMPACT DISC (CD) CHANGER

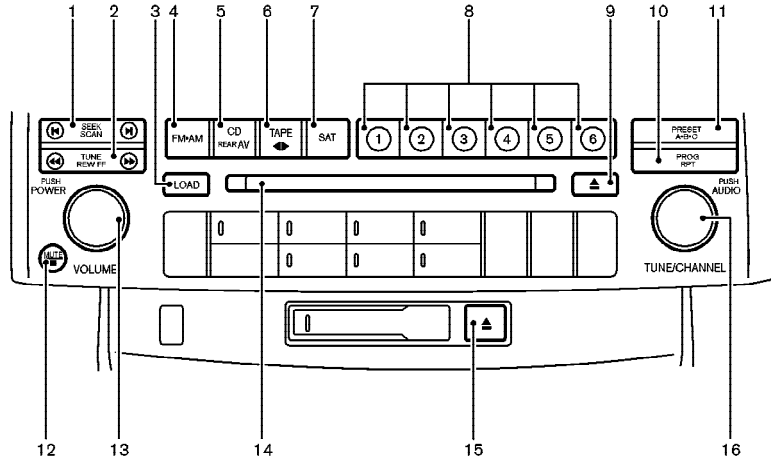

SAA0711

1. SEEK/APS REW, APS FF/TRACK CHANGE button
2. RADIO TUNE/FF·REW button
3. CD LOAD button

4. FM-AM band select button
5. CD/REAR AV play button
6. TAPE play button

7. "SAT" satellite band select button — if so equipped
8. Station and preset (FM/AM/SAT)/CD insert/eject or CD play select button
9. CD EJECT button
10. PROG (program)/RPT (repeat) play button
11. A.B.C. preset select button
12. "PAUSE/MUTE" button
13. ON-OFF/VOLUME control knob
14. CD slot
15. TAPE EJECT button
16. Tuning up/down knob and AUDIO (BASS, TREBLE, FADE, and BALANCE, SSV and NR (Dolby)) knob

FM-AM-SAT RADIO WITH CASSETTE PLAYER AND COMPACT DISC (CD) CHANGER

Audio main operation

The tape deck employs a permalloy head which allows for improved reproduction of high frequency ranges. Noise is also greatly reduced by the combined use of the Dolby NR (Noise Reduction) system. The auto loudness circuit enhances the low frequency range automatically in both radio reception and tape and CD playback.

ON-OFF/Volume control:

Turn the ignition switch to ACC or ON, and then push the ON-OFF/Volume control knob while the system is off to call up the mode (radio, tape or CD) which was playing immediately before the system was turned off. When no CD or tape is loaded, the radio will come on. While the system is on, pushing the ON-OFF/Volume control knob turns the system off.

To turn the radio off, press the Power/Volume control knob.

Turn the ON-OFF/Volume control knob to adjust the volume.

This vehicle has **Speed Sensitive control**

Volume (SSV) for audio. The audio volume changes as the driving speed changes.

AUDIO knob (BASS, TREBLE, FADE, BALANCE, (SSV and NR (Dolby))):

Press the AUDIO knob to change the selecting mode as follows.

BASS → TREBLE → FADE → BALANCE → SSV → NR (when cassette playing)

To adjust BASS, Treble, Fader and Balance, press the AUDIO knob until the desired mode BASS, TREBLE, FADE or BALANCE appears in the display. Turn the Tuning knob to adjust Bass and Treble to the desired level. Use the Tuning knob also to adjust Fader or Balance modes. Fader adjusts the sound level between the front and rear speakers and Balance adjusts the sound between the right and left speakers.

To change the SSV mode to OFF, LOW, MID or HIGH, turn the Tuning knob to right or left.

To change the NR (Dolby) mode to OFF or ON, turn the Tuning knob to right or left while cassette tape is playing. When Dolby is ON, the display indicates the **DD** mark.

Dolby noise reduction manufactured under license from Dolby Laboratories Licensing Corporation. Dolby NR and the double-D symbol

“ **DD** ” are trademarks of Dolby Laboratories Licensing Corporation.

After 10 seconds, the radio, cassette tape or CD display reappears. Once the sound quality is set to the desired level, press the AUDIO button repeatedly until the radio, cassette tape or CD display appears.

Display CD text:

To indicate the CD mode text, push the AUDIO knob during CD playing.

Track title → Disc title → BASS → TREBLE → FADE → BALANCE → SSV → Display mode

To change the indicated text in display mode, turn the tuning knob within 10 seconds.

The text will change as follows:

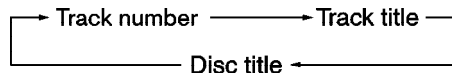

Display satellite radio text:

To indicate the satellite mode text, push the AUDIO knob during satellite radio play.

Artist → Title → BASS → TREBLE → FADE → BALANCE → SSV → Display mode

To change the indicated text in display mode, turn the tuning knob within 2 seconds.

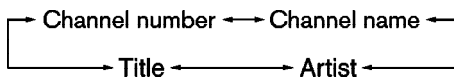

PAUSE MUTE **Pause/mute button:**

To mute or pause the audio sound, push the PAUSE/MUTE button.

To release the mute or pause, push the button again.

FM-AM-SAT radio operation

FM / AM or **SAT** **FM/AM/SAT band select:**

Pushing the FM/AM or SAT band select button will change the band as follows:

AM ↔ FM or SAT (Satellite)

When FM/AM/SAT band select button is pushed while the ignition switch is in the ACC or ON, the radio will come on at the station last played.

The last station played will also come on when the power knob is turned to ON.

If you have not separately contracted for satellite radio, "NO SAT" will be shown on the display.

If a compact disc or tape is playing when the FM/AM/SAT band select button is turned to

ON, the compact disc or tape will automatically be turned off and the last radio station played will come on.

The FM stereo indicator ST will glow during FM stereo reception. When the stereo broadcast signal is weak, the radio will automatically change from stereo to monaural reception.

TUNE (Tuning):

 **WARNING**

The radio should not be tuned while driving so full attention may be given to vehicle operation.

To tune the radio, push the RADIO TUNE button (▶▶ or ◀◀) or turn the Tuning knob to right or left.

Use these buttons for manual tuning. To move quickly through the channels, hold either of the RADIO TUNE buttons down for more than 1.5 seconds.

  **SEEK/SCAN tuning:**

Push the SEEK button ▶| or |◀ for less than 1.5 seconds, to tune from high to low or

low to high frequencies and stops at the next broadcasting station.

Push the ▶| or |◀ SEEK button for more than 1.5 seconds to tune from low to high frequencies and stops at each broadcasting station for 5 seconds. Pushing the button again during this 5 seconds period will stop SCAN tuning and the radio will remain tuned to that station.

If the SEEK button is not pushed within 5 seconds, SCAN tuning moves to the next station.

Station memory operations:

Eighteen (18) stations can be set for the FM, AM and SAT band to the A, B and C preset button.

1. Choose preset channel A, B or C using the preset select button.
2. Tune to the desired station using the SEEK, SCAN or TUNE button.
3. Push and hold any of the desired station memory buttons (1 to 6) until a beep sound is heard. (The radio mutes when the select button is pushed.)
4. The channel indicator will then come on and the sound will resume. Memorizing is now complete.

5. Other buttons can be set in the same manner.

If the battery cable is disconnected, or if the fuse blows, the radio memory will be erased. In that case, reset the desired stations.

Radio data system (RDS):

RDS stands for Radio Data System, and is a data information service transmitted by some radio stations on the FM band (not AM band) and/or SATELLITE band encoded within a regular radio broadcast. Currently, most RDS stations are in large cities, but many stations are now considering broadcasting RDS data.

RDS can display:

- Station call sign, such as "WHFR 98.3".
- Station name, such as "The Groove".
- Music or programming type such as "Classical", "Country", or "Rock".
- Traffic reports about delays or construction.

If the station broadcasts RDS information, the RDS icon is displayed.



Program type (PTY) (Category (CAT)):

When PROG/RPT button is pressed for more than 1.5 seconds during FM (SAT) mode, the PTY (CAT) name of the current tuned station is displayed. During this time if the PTY (CAT) data code is zero, or the data is unreadable; the display will show NONE.

1. PTY (CAT) selection mode

PTY (CAT) name selection can be done by the up/down TUNE button ►► or ◀◀ in the PTY (CAT) selection mode.

It is possible to shift the PTY (CAT) name by one step, with one push of the up/down tuning button ►► or ◀◀ .

PTY name selection can also be achieved by pressing the preset buttons.

Initial PTY names are stored in the preset buttons; but these can be changed by pressing the preset buttons for less than 1.5 seconds when the desired PTY name is in the display.

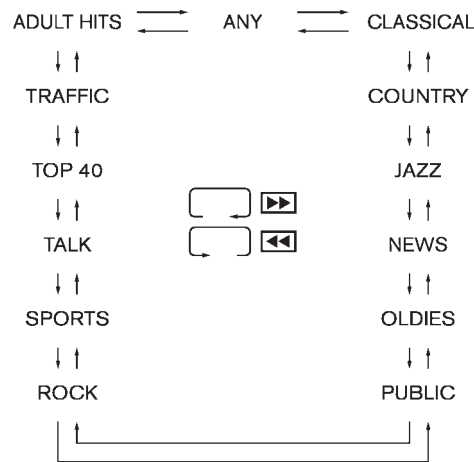

2. PTY SEEK tuning

After selecting a PTY name, push the SEEK button ►| or |◀ for less than 0.5 seconds within 10 seconds. Tuning to the PTY station will start. If you do not push the SEEK button within the 10 second period, the PTY mode will be canceled.

Push the SEEK button for more than 1.5 seconds to tune the PTY name station, and stop at each broadcasting station for 5

seconds. Pushing the button again during this 5 second period will stop SCAN tuning and the radio will remain tuned to that station. If the SEEK button is not pushed within 5 seconds, SCAN tuning moves to the next station.

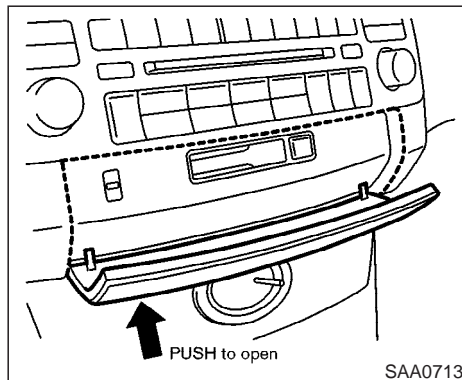

Cassette tape player operation

Turn the ignition switch to ACC or ON, and then lightly insert the cassette tape into the tape door. The cassette tape will be automatically pulled into the player.

The radio or CD will turn off (if it is on) and the cassette tape will begin to play.



CAUTION

Do not force the cassette tape into the tape door. This could cause player

damage.

If the system is turned off by pushing the ON-OFF/VOL control knob with the cassette tape still in the player, the tape will resume playing when the system is turned back on.

TAPE **PLAY:**

- When the TAPE button is pushed with the system turned off and a tape loaded, the system will come on and the tape will play.
- When the TAPE button is pushed with either the radio or compact disc turned on and the tape loaded, the compact disc or the radio will automatically be turned off and the tape will play.
- When the TAPE button is pushed with the TAPE playing, the tape will play the program recorded on the reverse side.



FF (Fast Forward), REW (Rewind):

Push the **▶▶** (fast forward) button to fast forward the tape. To rewind the tape, push the **◀◀** (rewind) button. Either the FF or REW symbol illuminates on the display window. To stop the FF or REW function, press the

▶▶ (fast forward) or ◀◀ (rewind) again, or the TAPE button.



APS (Automatic Program Search) FF, APS REW:

When the ▶| (APS FF) button is pushed for less than 1.5 seconds while the tape is being played, the next program will start to play from the beginning. Push the ▶| (APS FF) button several times to skip through programs. The tape will advance the number of times the button is pushed (up to nine programs).

When the |◀ (APS REW) button is pushed for less than 1.5 seconds once, the program being played starts over from the beginning. Push the |◀ (APS REW) button several times to skip back several selections. The tape will go back the number of times the button is pushed. Either the FF or REW symbol flashes on the display window while searching for the selection.

When pushing the ▶| (APS FF) or |◀ (APS REW) button for more than 1.5 seconds, each program will play for about 10 seconds. To stop playing, push the ▶| button again.

This system searches for the blank intervals between selections. If there is a blank interval within one program or there is no interval

between programs, the system may not stop in the desired or expected location.



REPEAT (RPT):

When the PROG/RPT play button is pushed while the tape is played, pattern can be changed as follows:

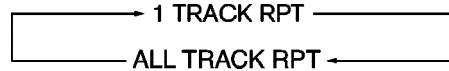

Metal or chrome tape usage:

The cassette player will be automatically set to high performance play when playing a metal or chrome cassette tape.



TAPE EJECT:

When this button is pushed with the tape loaded, the tape will be ejected.

When the tape is ejected while it is being played, the system will be turned off.

Compact disc (CD) changer operation

Turn the ignition switch to the ACC or ON position and insert the compact disc into the slot with the label side facing up. The compact disc will be guided automatically into the slot

and start playing. To insert the disc, first push the LOAD button.

After loading the disc, the number of tracks on the disc and the play time will appear on the display.

If the radio or tape is already operating, it will automatically turn off and the compact disc will play.



CAUTION

Do not force the compact disc into the slot. This could damage the player.

If the system has been turned off while the compact disc was playing, pushing the ON-OFF/VOL control knob will start the compact disc.

LOAD button:

To insert a CD in the CD changer, push the LOAD button for less than 1.5 seconds. Select the loading slot by pushing the CD insert select button (1 to 6), then insert the CD.

To insert 6 CDs to the CD changer, push the LOAD button for more than 1.5 seconds.

The inserted slot numbers will illuminate on the display.

PLAY:

When the CD/REAR AV button is pushed with the system off and the CD loaded in the CD changer, the CD changer or the rear INFINITI mobile entertainment system (if so equipped) will start to play.

Pushing the CD/REAR AV button changes operations alternately as follows:



CD → DVD → CD

When the CD/REAR AV button is pushed with the CD loaded with another audio source playing, the other source will automatically be turned off and

- the CD will start to play if the last play was a CD.
- the DVD will start to play if the last play was a DVD.

FF (Fast Forward), REW (Rewind):



The following functions are available only for CD changer, not available for family entertainment system.



When the  (fast forward) or  (rewind) button is pushed while the compact disc is being played, the compact disc will play while fast forwarding or rewinding. When the button

is released, the compact disc will return to normal play speed.



APS (Automatic Program Search) FF, APS REW:

When the  (APS FF) button is pushed for less than 1.5 seconds while the compact disc is being played, the program next to the present one will start to play from its beginning. Push several times to skip through programs. The compact disc will advance the number of times the button is pushed. (When the last program on the compact disc is skipped through, the first program will be played.) When the  (APS REW) button is pushed for less than 1.5 seconds, the program being played returns to its beginning. Push several times to skip back through programs. The compact disc will go back the number of times the button is pushed.

When pushing the  (APS FF) or  (APS REW) button for more than 1.5 seconds, each track will play for about 10 seconds. To stop playing, push the  button again.

CD PLAY button:

To change CD, push the CD play select button (1 to 6). You can select if the CD is inserted.

REPEAT (RPT):

When the PROG/RPT play button is pushed while the compact disc is played, the play pattern can be changed as follows:

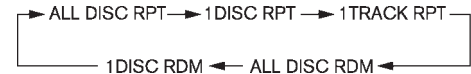

CD EJECT:

When the CD EJECT button is pushed with the compact disc loaded, the compact disc will be ejected.

To eject the discs selected by the EJECT button, push it for less than 1.5 seconds.

To eject all the discs, push the EJECT button for more than 1.5 seconds.

When this button is pushed while the compact disc is being played, the compact disc will come out and the system will turn off.

If the compact disc comes out and is not removed, it will be pulled back into the slot to protect it. (except 8 cm diameter compact discs)

CD IN indicator:

CD IN indicator appears on the display when the CD is loaded with the system on.

DVD OFF function:

It is possible to turn off the INFINITI Mobile Entertainment System (MES) from the front seat. When the ON-OFF switch is turned off when the DVD is being played from the speakers (with DVD displayed), the MES is turned off. (The audio system will not turn off. If a CD is loaded, the CD will be played.) Pushing the CD/REAR AV button with no DVD discs loaded will turn on the MES (mute).

The sound resumes when a DVD disc is loaded or another audio source is connected to the auxiliary input jacks.

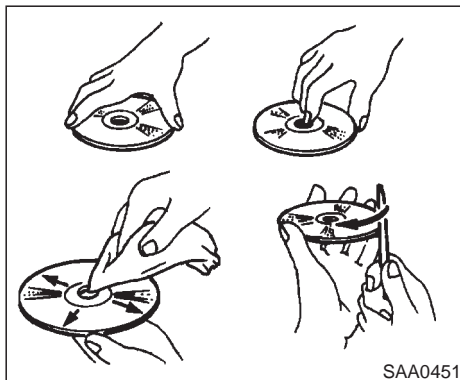

ing the side of a pen or pencil as illustrated.

CD CARE AND CLEANING

- Handle a CD by its edges. Never touch the surface of the disc. Do not bend the disc.
- Always place the discs in the storage case when they are not being used.
- To clean a disc, wipe the surface from the center to the outer edge using a clean, soft cloth. Do not wipe the disc using a circular motion.
Do not use a conventional record cleaner or alcohol intended for industrial use.
- A new disc may be rough on its inner and outer edges. Remove the rough edges us-

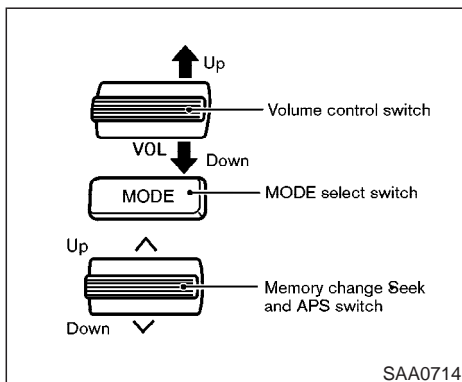

STEERING SWITCH FOR AUDIO CONTROL (if so equipped)

The audio system can be operated using the controls on the steering wheel.

MODE select switch

Push the mode select switch to change the mode in the sequence of FM, AM, SAT, CD and Tape.

This mode switch will not change the DVD (MES).

Volume control switches

Push the volume control switch to increase or decrease the volume.



Memory change (radio):

Push the tuning switch or for less than 1.5 seconds to change the radio frequency.

Seek tuning (radio):

Push the tuning switch or for more than 1.5 seconds to seek the next or previous radio station.

APS (Automatic Program Search) FF, APS REW (tape and CD):

Push the tuning switch or for less than 1.5 seconds to return to the beginning of the present program or skip to the next program. Push several times to skip back or skip through programs.

This system searches for the blank intervals between selections. If there is a blank interval within one program or there is no interval between programs, the system may not stop in the desired or expected location.

FF REW (tape or CD):

Push the tuning switch or for more than 1.5 seconds to rewind or fast forward the tape or to change the playing disc up or down.

To stop the FF or REW function, press the or button for less than 1.5 seconds again.

**INFINITI MOBILE
ENTERTAINMENT SYSTEM (MES)
(if so equipped)**

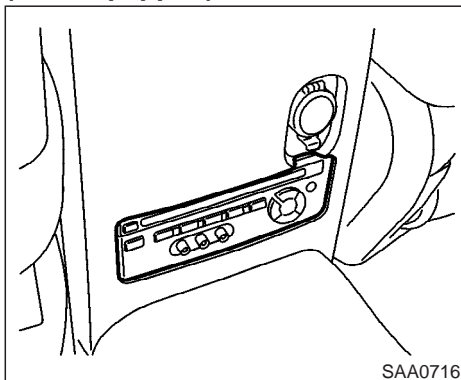

WARNING

- The Mobile Entertainment System (MES) is designed for rear seat passenger viewing only.
- The driver must not attempt to operate the MES while the vehicle is in motion so that full attention may be given to vehicle operation.



CAUTION

- The glass screen on the liquid crystal display may break if hit with a hard or sharp object. If the glass breaks, do not touch the liquid crystalline material, which contains a small amount of mercury. In case of contact with skin, wash immediately with soap and water.
- Use a damp, soft cloth when cleaning the Mobile Entertainment System components. Do not use solvents or cleaning solutions.
- Do not attempt to use the system in extreme temperature conditions [below -4°F (-20°C) or above 158°F (70°C)].
- To avoid draining the vehicle battery, do not operate the system more than 15 minutes without starting the engine.

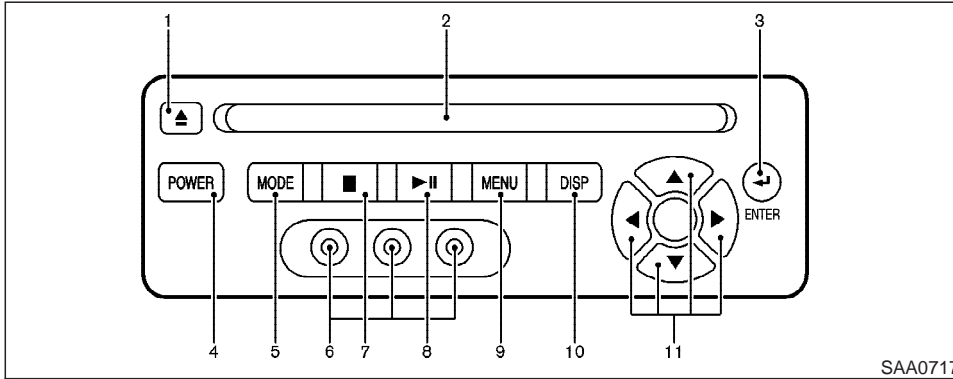

SAA0717

DIGITAL VIDEO DISC (DVD) PLAYER CONTROLS

The DVD player has the following controls:

1. EJECT button
2. DVD slot
3. ENTER button
4. POWER on/off switch
5. MODE button
6. Input jacks
7. STOP button
8. PLAY/PAUSE button
9. MENU button
10. DISPLAY button
11. NAVIGATION KEYS

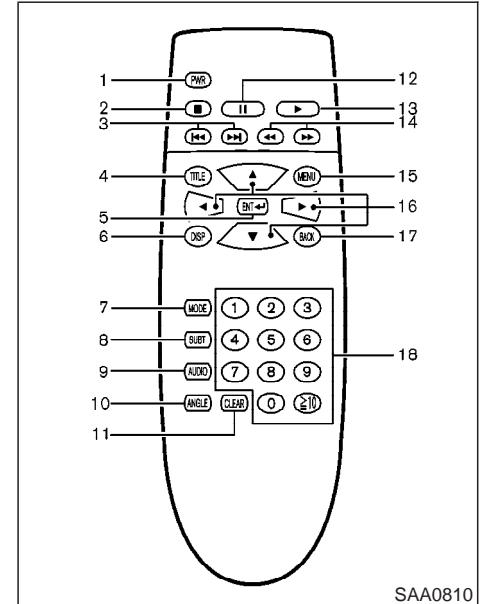

SAA0810

REMOTE CONTROL

The remote control has the following controls:

1. ON-OFF button
2. STOP button

3. NEXT TRACK/CHAPTER and PREVIOUS TRACK/CHAPTER button
4. TITLE button
5. ENTER button
6. DISPLAY button
7. MODE button
8. SUBTITLE button
9. AUDIO button
10. ANGLE button
11. CLEAR button
12. PAUSE button
13. PLAY button
14. FAST FORWARD/FAST REVERSE button
15. MENU button
16. NAVIGATION KEYS
17. RETURN button
18. NUMERIC KEYPAD

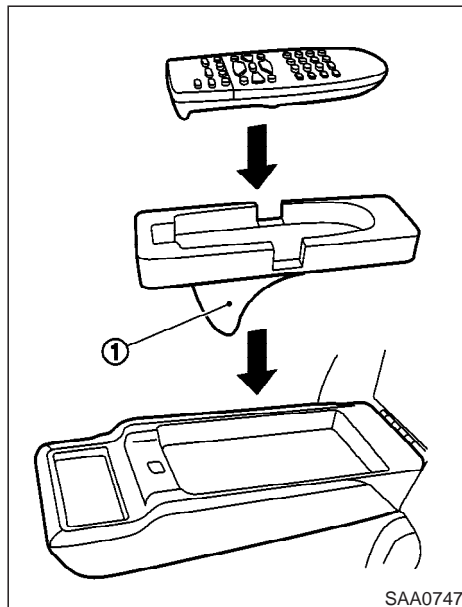

REMOTE CONTROL HOLDER

Peel the sheet ① of the holder off, then put the remote control holder to the desired position in the rear armrest.

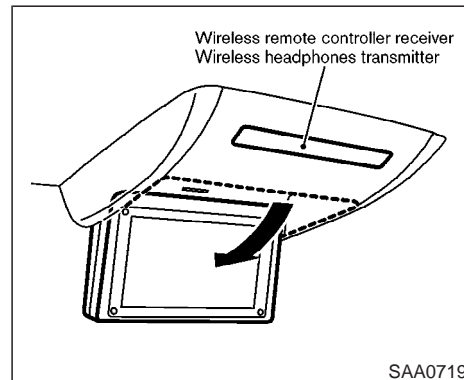

FLIP-DOWN SCREEN



CAUTION

- The glass screen on the liquid crystal display may break if hit with a hard or sharp object. If the glass breaks, do not touch the liquid crystalline material, which contains a small amount of mercury. In case of contact with skin, wash immediately with soap and water.

- The screen rotates down to view and up into the housing to store when not in use. Ensure that the screen is latched securely into the housing when stored.

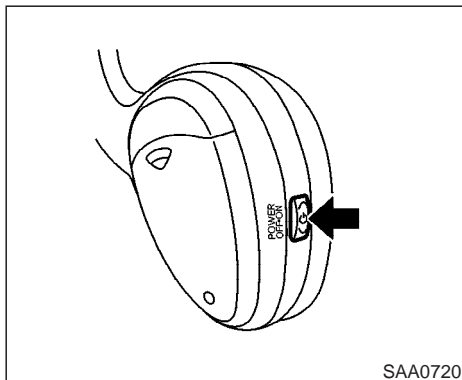

Headphones

Power ON/OFF:

Push the POWER button to turn the headphones on or off.

Volume control:

Turn the volume control knob to adjust the volume.

The headphones will automatically be turned off in 30 seconds if there is no sound during that period. To prevent the battery from being discharged, keep the power supply turned off when not in use.

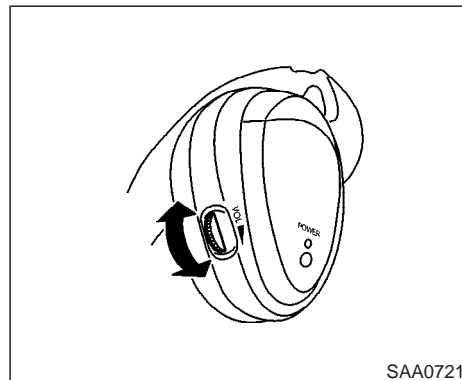

PLAYING A DIGITAL VIDEO DISC (DVD)



CAUTION

- Only operate the DVD while the vehicle engine is running. Operating the DVD for extended periods of time with the engine OFF can discharge the vehicle battery.
- Do not allow the system to get wet. Excessive moisture such as spilled

liquids may cause the system to malfunction.

- The driver must not attempt to wear the headphones while the vehicle is in motion so that full attention may be given to vehicle operation.
- While playing video CD media, this DVD player does not guarantee complete functionality of all video CD formats.

With the DVD player, you can hear DVD videos, video CDs and CDs using headphones. Passengers in the rear seat can enjoy the sound independently of the front seat.

Using the CD/rear AV button located on the front seat, you can also hear the sound of the DVD player through the speakers in the vehicle.

It is possible to operate the DVD player by remote control.

Headphones are a wireless type and no cables are necessary. You can use them in almost all the ranges in the rear seat. (It is not possible to use the headphones in the front seat.)

POWER on/off button:

With the ignition switch turned to the ACC or ON position, push the POWER button to turn the DVD player on or off.

Insert the compact disc into the slot with the label side facing up. The digital video disc will be guided automatically into the slot.



CAUTION

Do not force the compact disc into the slot. This could damage the player.

MODE select switch:

Push the Mode button to select Audio/Video source between DVD and AUX input (input jacks on the faceplate, Red = right channel audio input, White = left channel audio input, and Yellow = Video input).

The display will show the "AUX" in the upper left corner of the display for 4 seconds once the Mode is changed to AUX.

To use the input jacks, refer to "Auxiliary input jacks" in this section.



When the PLAY/PAUSE button on the player

or the PLAY button on the remote control is pushed, the player will play.

In play mode, the display will show ► on the upper left corner of the display.



FF (Fast Forward), REW (Rewind) (Remote control only):

Push FAST FORWARD/FAST REVERSE buttons to carry out the fast forward or fast reverse presentation at 5 times normal play speed.

Push FAST FORWARD/FAST REVERSE buttons again or PLAY button to resume the normal play speed.



**NEXT CHAPTER/
PREVIOUS CHAPTER:**

When the ►► (NEXT CHAPTER) button is pushed while the digital video disc is being played, the program next to the present one will start to play from its beginning. Push several times to skip through programs. The digital video disc will advance the number of times the button is pushed. When the ◀◀ (PREVIOUS CHAPTER) button is pushed, the program being played returns to its beginning. Push several times to skip back through programs. The digital video disc will

go back the number of times the button is pushed.



When the PLAY/PAUSE button on the player or the PAUSE button on the remote control is pushed, the player will pause playing of the media. In pause mode, the player will show

⏸ on the upper left corner of the display until the player is changed to another mode.

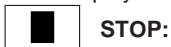

Push the STOP button once to stop playing the media. The display will show ■ in the upper left corner of the display for 4 seconds, and the last disc position will be stored. When the PLAY button is pushed again, it will resume at the stored disc track and time position.

If the STOP button is pushed again when the player is already in Stop mode, it will reinitialize the pointer to the beginning of the disc. In effect it will ignore the last stored disc position and upon receipt of the next play message it will begin at the Title Menu, or at “the beginning of the disc”.



When the EJECT button is pushed with the digital video disc loaded, it will be ejected.

The display will show the EJECT symbol

⏏ in the upper left corner of the display for 4 seconds once the EJECT button is pushed.

If the digital video disc is not loaded, the display will show “NO DISC”.

If the digital video disc comes out and is not removed within 25 seconds, it will be pulled back into the slot to protect it.

DISPLAY:

If the DISPLAY control is pushed for less than 2 seconds, the display menu will appear on the screen.

- The display menu will remain on the screen for 10 seconds if no subsequent control activations occur.
- Use NAVIGATION KEYS to navigate within the display menu, and use ENTER to select the item.
- Holding the DISPLAY control on the faceplate for longer than approximately 2 seconds while in the display menu will reset the display characteristics to their nominal values. (Faceplate feature only)

If the DISPLAY control button on the faceplate is pushed for more than 2 seconds, the media track/time information will be displayed along the bottom of the display. Pushing the DISPLAY control for more than 2 seconds will

remove the media track/time information from the display. (Faceplate feature only)

NAVIGATION KEYS:

If media is in PLAY mode, activation of the NAVIGATION KEYS (Up, Down, Left, and Right) will perform the following functions: next chapter/track, previous chapter/track, fast reverse and fast forward, and the display will show ▶|, |◀ and ◀◀, ▶▶ respectively in the upper left corner of the display for 4 seconds. (Faceplate feature only)

If media is in PAUSE mode, activation of the NAVIGATION KEYS (Up, down and Right) will perform the following functions: next chapter/track, previous chapter/track and slow forward, and the display will show ▶|, |◀ and |▶ respectively in the upper left corner of the display for 4 seconds. (Faceplate feature only)

If media is in activated MENU mode, the NAVIGATION KEYS will be used to navigate Up, Down, Left, and Right within the menu.

If display control menu is on, the NAVIGATION KEYS will be used to navigate Up, Down, Left, and Right within the menu.

ENTER:

In MENU mode, push the ENTER button to select MENU items.

In the display menu, push the ENTER button to select items for modification, as per the on-screen instructions.

MENU:

If the media is in PLAY mode and the MENU button is pressed, the DVD menu will appear on the screen. Use Navigation Keys to navigate within the menu, and use ENTER to select the item.

Push the MENU button again to return to PLAY mode.

TITLE (Remote control only):

Push TITLE button to return the DVD media to the "title" of the DVD.

Push TITLE button again to return to the previous stop point and play.

RETURN (Remote control only):

Push RETURN function to exit the current active menu and return to the previous menu.

SUBTITLES (Remote control only):

Push the SUBTITLES button to call-up subtitle selection menu.

Repeatedly press the SUBTITLE button to cycle through each available subtitle.

AUDIO (Remote control only):

Push the AUDIO button to call-up audio menu.

Repeatedly press the AUDIO button to cycle through each available audio track.

ANGLE (Remote control only):

Push the ANGLE button to call-up camera angle menu.

Repeatedly press the ANGLE button to cycle through each available angle.

CLEAR (Remote control only):

Push the CLEAR button to clear all numeric inputs, if actuated prior to expiration of the 3-second timer.

NUMERIC KEYPAD (0-9 & ≥ 10) (Remote control only):

Push the NUMERIC KEYPAD to directly access disc chapters, titles or tracks by inputting their numeric value.

The " ≥ 10 " button input numbers greater than or equal to 10, allowing up three digits to be input for selecting chapter/title/track number.

The subsequent actuation of numeric buttons will continuously shift the previously input number to the "left".

The chapter/title/track number will be auto-

matically selected (if valid, based on media content) if 3 seconds expire without any keypad inputs.

The operator can cancel the input chapter/title/track number by actuating the CLEAR control prior to the expiration of the 3-second timer.

These functions can be used only for the DVD discs which correspond to them.

Auxiliary input jacks

The auxiliary input jacks are located on the control panel. Compatible devices such as video games camcorders and portable video players can be connected to the auxiliary jacks.

The auxiliary jacks are color coded for identification purposes.

- Yellow - video input
- White - left channel audio input
- Red - right channel audio input

CARE AND MAINTENANCE

Use a lightly dampened, lint free cloth to clean the surfaces of your Mobile Entertainment System. (DVD player face, screen, remote control, etc.)

HOW TO HANDLE THE DVD



CAUTION

- Do not use any solvents or cleaning solutions when cleaning the video system.
- Do not use excessive force on the monitor screen.
- Avoid touching or scratching the monitor screen as it may become dirty or damaged.
- Do not attempt to operate the system in extreme temperature conditions [below -4°F (-20°C) and above 158°F (70°C)].
- Do not attempt to operate the system in extreme humidity conditions (less than 10% or more than 75%).

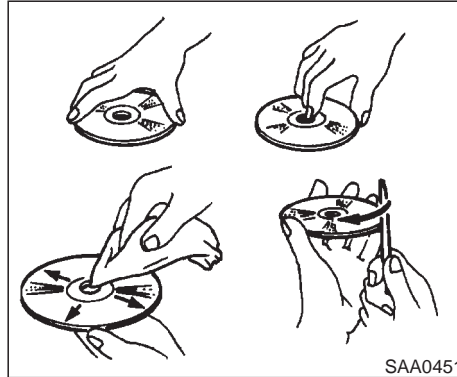

CAUTION

- Handle a DVD by its edges. Never touch the surface of the disc.
- To clean a disc, wipe the surface from the center to the outer edge using a clean, soft cloth. Do not wipe the disc using a circular motion.
- Do not use a conventional record cleaner, benzine, thinner or alcohol intended for industrial use.

- A new disc may be rough on its inner and outer edges. Remove the rough edges using the side of a pen or pencil as illustrated.
- Never attempt to use a DVD that has been cracked, deformed, or repaired using adhesive. Doing so may cause damage to the equipment.

- Handle the DVD carefully to avoid contamination or flaws. Otherwise, signals may not be read properly.
- Do not write, draw or attach anything on any side of the DVD.
- Do not store the DVD in locations with direct sunlight or in high temperatures or humidity.
- Always place discs in the storage case when they are not being used.
- Do not put on any sticker or write anything on either surface of the DVD.

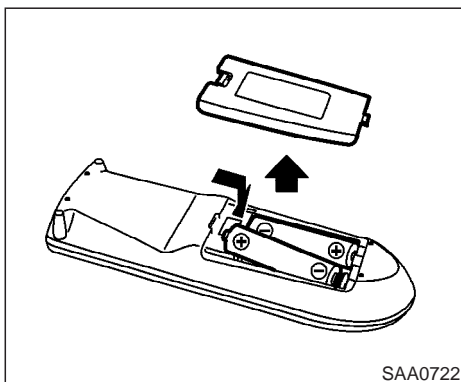

Remote control and headphones battery replacement

Replace the battery as follows:

1. Open the lid.
2. Replace both batteries with new ones.
 - Size AA (remote control)
 - Size AAA (headphones)

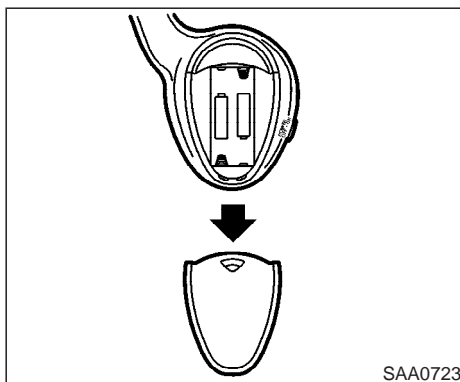

Make sure that the \oplus and \ominus ends on the batteries match the markings inside the compartment.

3. Close the lid securely.

If the battery is removed for any reason other than replacement, perform step 3 above.

- If you will not be using the remote control for long periods of time, remove the batteries.
- Replacement of the batteries is needed when the remote control only functions

at extremely close distances to the MES or not at all.

- Be careful not to touch the battery terminal.
- An improperly disposed battery can harm the environment. Always confirm local regulations for battery disposal.
- When changing batteries, do not let dust or oil get on the remote control and headphones.

FCC Notice:

Changes or modifications not expressly approved by the manufacturer compliance could void the user's authority to operate the equipment. This device complies with Part 15 of the FCC Rules and RSS-210 of Industry Canada. Operation is subject to the following two conditions: (1) This device may not cause harmful interference, and (2) this device must accept any interference received, including interference that may cause undesired operation of the device.

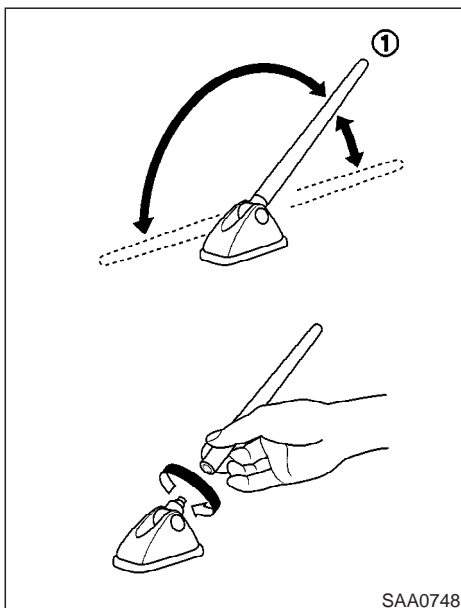

ANTENNA

Placing the antenna

You can adjust the antenna to three different positions manually.

INFINITI recommends position ① for the best radio reception

Removing the antenna

You can remove the antenna if necessary.

Hold the bottom of the antenna and remove by turning counterclockwise.



CAUTION

- Be sure that antenna is removed before the vehicle enters an automatic car wash.
- Be sure to fold down the antenna before the vehicle enters a garage with a low ceiling.

CAR PHONE OR CB RADIO

When installing a CB, ham radio or car phone in your INFINITI, be sure to observe the following cautions, otherwise the new equipment may adversely affect the Engine control system and other electronic parts.



WARNING

- A cellular telephone should not be used while driving so full attention may be given to vehicle operation. Some jurisdictions prohibit the use of cellular telephones while driving.
- If you must make a call while your vehicle is in motion, the hands free cellular phone operational mode (if so equipped) is highly recommended. Exercise extreme caution at all times so full attention may be given to vehicle operation.
- If a conversation in a moving vehicle requires you to take notes, pull off the road to a safe location and stop your vehicle before doing so.



CAUTION

- Keep the antenna as far as possible away from the electronic control modules.
- Keep the antenna wire more than 8 in (20 cm) away from the electronic control system harnesses. Do not route the antenna wire next to any harness.
- Adjust the antenna standing-wave ratio as recommended by the manufacturer.
- Connect the ground wire from the CB radio chassis to the body.
- For details, consult an INFINITI dealer.

MEMO

5 Starting and driving

Precautions when starting and driving.....	5-2	Intelligent Cruise Control system	
Exhaust gas (Carbon monoxide).....	5-2	(if so equipped)	5-18
Three way catalyst	5-3	How to change the intelligent cruise control	
On-pavement and offroad driving precautions	5-3	mode.....	5-19
Low tire pressure warning system (if so		Vehicle-to-vehicle distance control mode.....	5-19
equipped).....	5-3	Conventional (fixed speed) cruise control	
Avoiding collision and rollover.....	5-5	mode.....	5-34
Drinking alcohol/drugs and driving.....	5-5	Brake assist (with preview function) (for Intelligent	
Driving safety precautions	5-5	Cruise Control system equipped models).....	5-37
Ignition switch (except Intelligent Key system)	5-8	Brake assist.....	5-37
Key positions	5-8	Preview function	5-37
Infiniti Vehicle Immobilizer System.....	5-9	Break-in schedule	5-40
Ignition knob (models with the Intelligent Key		Increasing fuel economy	5-40
System)	5-9	AWD warning light	5-41
Ignition knob positions.....	5-10	Parking/parking on hills.....	5-42
Infiniti Vehicle Immobilizer System.....	5-10	Power steering	5-43
Before starting the engine.....	5-11	Brake system	5-44
Starting the engine.....	5-11	Braking precautions.....	5-44
Driving the vehicle.....	5-12	Preview function (for Intelligent Cruise Control	
Automatic transmission	5-12	system equipped models)	5-44
Parking brake	5-15	Anti-lock brake system (ABS)	5-44
Cruise control	5-16	Vehicle dynamic control (VDC) system	5-46
Precautions on cruise control.....	5-16	Cold weather driving	5-47
Cruise control operations	5-17	Freeing a frozen door lock	5-47

Anti-freeze	5-47
Battery	5-47
Draining of coolant water	5-47
Tire equipment	5-47

Special winter equipment	5-48
Driving on snow or ice	5-48
Engine block heater (if so equipped)	5-49



PRECAUTIONS WHEN STARTING AND DRIVING



WARNING

- Do not leave children or adults who would normally require the support of others alone in your vehicle. Pets should not be left alone either. They could accidentally injure themselves or others through inadvertent operation of the vehicle. Also, on hot, sunny days, temperatures in a closed vehicle could quickly become high enough to cause severe or possibly fatal injuries to people or animals.
- Properly secure all cargo to help prevent it from sliding or shifting. Do not place cargo higher than the seat-backs. In a sudden stop or collision, unsecured cargo could cause personal injury.

EXHAUST GAS (Carbon monoxide)



WARNING

Do not breathe exhaust gases; they con-

tain colorless and odorless carbon monoxide. Carbon monoxide is dangerous. It can cause unconsciousness or death.

- If you suspect that exhaust fumes are entering the vehicle, drive with all windows fully open, and have the vehicle inspected immediately.
- Do not run the engine in closed spaces such as a garage.
- Do not park the vehicle with the engine running for any extended length of time.
- Keep the back door closed while driving, otherwise exhaust gases could be drawn into the passenger compartment. If you must drive with the back door open, follow these precautions:
 1. Open all the windows.
 2. Set the air recirculation switch OFF and the fan control at maximum position to circulate the air.
- If electrical wiring or other cable con-

nections must pass to a trailer through the seal on the back door or the body, follow the manufacturer's recommendation to prevent carbon monoxide entry into the vehicle.

- If a special body or other equipment is added for recreational or other usage, follow the manufacturer's recommendation to prevent carbon monoxide entry into the vehicle. (Some recreational vehicle appliances such as stoves, refrigerator, heaters, etc. may also generate carbon monoxide.)
- The exhaust system and body should be inspected by a qualified mechanic whenever:
 - a. The vehicle is raised for service.
 - b. You suspect that exhaust fumes are entering into the passenger compartment.
 - c. You notice a change in the sound of the exhaust system.

- d. You have had an accident involving damage to the exhaust system, underbody, or rear of the vehicle.

THREE WAY CATALYST

The three way catalyst is an emission control device installed in the exhaust system. Exhaust gases in the converter are burned at high temperatures to help reduce pollutants.



WARNING

- The exhaust gas and the exhaust system are very hot. Keep people, animals or flammable materials away from the exhaust system components.
- Do not stop or park the vehicle over flammable materials such as dry grass, waste paper or rags. They may ignite and cause a fire.



CAUTION

- Do not use leaded gasoline. Deposits from leaded gasoline seriously reduce the three way catalyst's ability to help reduce exhaust pollutants.
- Keep your engine tuned up. Malfunctions in the ignition, fuel injection, or electrical systems can cause over-rich fuel flow into the three way catalyst, causing it to overheat. Do not keep driving if the engine misfires, or if noticeable loss of performance or other unusual operating conditions are detected. Have the vehicle inspected promptly by an INFINITI dealer.
- Avoid driving with an extremely low fuel level. Running out of fuel could cause the engine to misfire, damaging the three way catalyst.
- Do not race the engine while warming it up.
- Do not push or tow your vehicle to start the engine.

ON-PAVEMENT AND OFFROAD DRIVING PRECAUTIONS

Utility vehicles have a significantly higher rollover rate than other types of vehicles.

They have higher ground clearance than passenger cars to make them capable of performing in a variety of on-pavement and offroad applications. This gives them a higher center of gravity than ordinary cars. An advantage of higher ground clearance is a better view of the road, allowing you to anticipate problems. However, they are not designed for cornering at the same speeds as conventional two-wheel drive vehicles any more than low-slung sports cars are designed to perform satisfactorily under offroad conditions. If at all possible, avoid sharp turns or abrupt maneuvers particularly at high speeds. As with other vehicles of this type, failure to operate this vehicle correctly may result in loss of control or vehicle rollover.

LOW TIRE PRESSURE WARNING SYSTEM (if so equipped)

This vehicle is equipped with the low tire pressure warning system. It monitors tire pressure of all tires except the spare. When the low tire pressure warning light is lit, one or more of

your tires is significantly under-inflated. The system also displays pressure of all tires (except the spare tire) on the display screen by sending a signal from a sensor that is installed in each wheel.

The low tire pressure warning system will activate only when the vehicle is driven at speeds above 20 MPH (32 km/h). Also, this system may not detect a sudden drop in tire pressure (e.g. a flat tire while driving).

Frequently check the tire pressure information display on the display screen and adjust pressure of each tire properly. (The order of the tire pressure figures displayed on the screen does not correspond with the actual order of the tire position.) See "Tire pressure information" in the "4. Display screen, heater, air conditioner and audio systems" section for tire pressure monitor. If you select the tire pressure information in the display (if so equipped), the FLAT TIRE warning message will be displayed.

Low tire pressure warning system

If the vehicle is being driven with low tire pressure (lower than 26 psi, 180 kPa). The low tire pressure warning light comes on, and the chime sounds for about 10 seconds. If you select the tire pressure information in the display, the FLAT TIRE warning message will be displayed.

5-4 Starting and driving



WARNING

- If the low tire pressure warning light comes ON and/or FLAT TIRE warning is displayed on the display screen while driving, avoid sudden steering maneuvers or abrupt braking, reduce vehicle speed, pull off the road to a safe location and stop the vehicle as soon as possible. Serious vehicle damage could occur and may lead to an accident and could result in serious personal injury. Check the pressure for all four tires. Adjust the tire pressure to the COLD tire pressure shown on the Tire and Loading Information label to turn the low tire pressure warning light OFF. If you have a flat tire, replace it with a spare tire as soon as possible. (See "Flat tire" in the "6. In case of emergency" section for changing a flat tire.)
- When a spare tire is mounted or a wheel is replaced, the tire pressure will not be indicated and the low tire

pressure warning system will not function. Contact your INFINITI dealer as soon as possible for tire replacement and/or system resetting.

- Do not inject any tire liquid or aerosol tire sealant into the tires, as this may cause a malfunction of the tire pressure sensors.



CAUTION

Do not place metalized film or any metal parts (antenna, etc.) on the windows. This may cause poor reception of the signals from the tire pressure sensors, and the low tire pressure warning system will not function properly.

FCC Notice:

Changes or modifications not expressly approved by the manufacturer compliance could void the user's authority to operate the equipment.

This device complies with Part 15 of the FCC Rules and RSS-210 of Industry Canada.

Operation is subject to the following two conditions: (1) This device may not cause harmful interference, and (2) this device must accept any interference received, including interference that may cause undesired operation of the device.

AVOIDING COLLISION AND ROLLOVER



WARNING

Failure to operate this vehicle in a safe and prudent manner may result in loss of control or an accident.

Be alert and drive defensively at all times. Obey all traffic regulations. Avoid excessive speed, high speed cornering, or sudden steering maneuvers, because these driving practices could cause you to lose control of your vehicle. **As with any vehicle, a loss of control could result in a collision with other vehicles or objects, or cause the vehicle to rollover, particularly if the loss of control causes the vehicle to slide sideways.** Be attentive at all times, and avoid driving when tired. Never drive when under the influence of alcohol or drugs (including prescription or over-the-counter drugs which may cause

drowsiness). Always wear your seat belt. See “Seat belts” in the “1. Seats, restraints and supplemental air bag systems” section. Also instruct your passengers to do so.

Seat belts help reduce the risk of injury in collisions and rollovers. **In a rollover crash, an unbelted person is significantly more likely to be injured or killed than a person properly wearing a seat belt.**

DRINKING ALCOHOL/DRUGS AND DRIVING



WARNING

Never drive under the influence of alcohol or drugs. Alcohol in the bloodstream reduces coordination, delays reaction time and impairs judgment. Driving after drinking alcohol increases the likelihood of being involved in an accident injuring yourself and others. Additionally, if you are injured in the accident, alcohol can increase the severity of the injury.

INFINITI is committed to safe driving. You must not drive under the influence of alcohol.

Every year thousands of people are injured or killed in alcohol related accidents. Although the local laws vary on what is considered to be legally intoxicated, the fact is that alcohol affects all people differently and most people underestimate the effects of alcohol.

Remember, drinking and driving don't mix!

And that's true for drugs too (over the counter, prescription, and illegal drugs). Don't drive if your ability to operate your vehicle is impaired by alcohol, drugs, or some other physical condition.

DRIVING SAFETY PRECAUTIONS

Please observe the following precautions:



WARNING

- **Drive carefully when off the road and avoid dangerous areas. Every person who drives or rides in this vehicle should be seated with their seat belt fastened. Keep you and your passengers in position when driving over rough terrain.**

- Before driving up or down grades, check the road surface for bumps or potholes. Be sure to climb a gentle slope and descend a gentle slope.
- Do not drive across steep slopes. Instead drive either straight up or straight down the slopes. Off-road vehicles can tip over sideways much more easily than they can forward or backward.
- Many hills are too steep for any vehicle. If you drive up them, you may stall. If you drive down them, you may not be able to control your speed. If you drive across them, you may roll over.
- Do not move selector lever while driving on downhill grades as this could cause loss of control of the vehicle.
- Be sure to use the engine brake. The foot brake performance may be reduced, resulting in a possible accident.
- Stay alert when driving to the top of a

hill. At the top there could be a drop-off or other hazard that could cause an accident.

- If your engine stalls or you cannot make it to the top of a steep hill, never attempt to turn around. Your vehicle could tip or roll over. Always back straight down in R (Reverse) range. Never back down in N (Neutral), using only the brake, as this could cause loss of control.
- Heavy braking going down a hill could cause your brakes to overheat and fade, resulting in loss of control and an accident. Apply brakes lightly and use a low range to control your speed.
- Unsecured cargo can be thrown around when driving over rough terrain. Properly secure all cargo so it will not be thrown forward and cause injury to you or your passengers.
- To avoid raising the center of gravity excessively, do not exceed the rated

capacity of the roof rack (if so equipped) and evenly distribute the load. Secure heavy loads in the cargo area as far forward and as low as possible. Do not equip the vehicle with tires larger than specified in this manual. This could cause your vehicle to roll over.

- Do not grip the inside or spokes of the steering wheel when driving off-road. The steering wheel could move suddenly and injure your hands. Instead drive with your fingers and thumbs on the outside of the rim.
- Before operating the vehicle, ensure that the driver and all passengers have their seat belts fastened.
- Always drive with the floor mats in place as the floor may become hot.
- Lower your speed when encountering strong crosswinds. With a higher center of gravity, your INFINITI is more affected by strong side winds. Slower speeds ensure better vehicle control.

- Do not drive beyond the performance of the tires, even with AWD engaged. Accelerating quickly, sharp steering maneuvers or sudden braking may cause loss of control.
- If at all possible, avoid sharp turning maneuvers, particularly at high speeds. Your INFINITI all-wheel drive vehicle has a higher center of gravity than a two-wheel drive vehicle. The vehicle is not designed for cornering at the same speeds as conventional two-wheel drive vehicles. Failure to operate this vehicle correctly could result in loss of control and/or a roll over accident.
- Always use tires of the same type, size, brand, construction (bias, bias-belted or radial), and tread pattern on all four wheels. Install tire chains on the rear wheels when driving on slippery roads and drive carefully.
- Be sure to check the brakes immediately after driving in mud or water. See “Brake system” later in this section for “wet brakes”.

- Avoid parking your vehicle on steep hills. If you get out of the vehicle and it rolls forward, backward or sideways, you could be injured.
- Whenever you drive off-road through sand, mud or water as deep as the wheel hub, more frequent maintenance may be required. See the maintenance schedule in the INFINITI Service and Maintenance Guide.
- Do not drive continuously on sandy or muddy roads with the rear wheels spinning. The AWD warning light blinks and the driving mode changes to 2WD. This could reduce traction force remarkably. Be especially careful when towing a trailer. (AWD models)
- A vehicle equipped with AWD (All-Wheel Drive) should never be tested using a two wheel dynamometer (such as the dynamometers used by some states for emissions testing), or

similar equipment. Make sure you inform test facility personnel that your vehicle is equipped with AWD before it is placed on a dynamometer. Using the wrong test equipment may result in transmission damage or unexpected vehicle movement which could result in serious vehicle damage or personal injury.

- Never operate the accelerator pedal with any wheels raised and the other wheels on the ground while jacking up or with any wheels on a roller and the other wheels on the ground. Otherwise, the vehicle could lurch forward or backward. (AWD models)
- When a wheel is off the ground due to an unlevel surface, do not spin the wheel excessively. (AWD models)
- When the vehicle is on a free roller or the front or rear wheels are jacked up, do not start the engine. The vehicle could lurch forward. (AWD models)

IGNITION SWITCH (except Intelligent Key system)

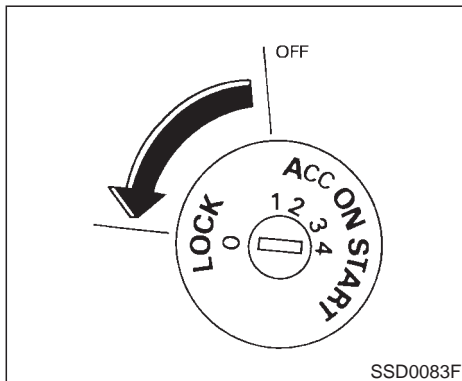

The ignition lock is designed so that the key cannot be turned to LOCK and removed until the selector lever is moved to the P (Park) position.

When removing the key from the ignition, make sure the selector lever is in the P (Park) position.

If the selector lever is not returned to P (Park) position, the key cannot be moved toward LOCK.

When the key cannot be turned toward the LOCK position, proceed as follows to remove the key:

5-8 Starting and driving

1. Move the selector lever into the P (Park) position.
2. Turn the ignition key slightly in the ON direction.
3. Turn the key toward the LOCK position.
4. Remove the key.

If the key is removed from the ignition switch, the selector lever cannot be moved from P (Park) position. **The selector lever can be moved if the ignition switch is in the ON position and the foot brake pedal is depressed.**

There is an OFF position in between LOCK and ACC, although it does not show on the lock cylinder. When the ignition is in OFF the steering wheel is not locked.

In order for the steering wheel to be locked, it must be turned about 1/6 of a turn clockwise from the straight up position.

To lock the steering wheel, turn the key to the LOCK position. Remove the key. To unlock the steering wheel, insert the key and turn it gently while rotating the steering wheel slightly right and left.



WARNING

Never remove or turn the key to the LOCK position while driving. The steering wheel will lock. This may cause the driver to lose control of the vehicle and could result in serious vehicle damage and/or personal injury.

KEY POSITIONS

The switch includes an anti-theft steering lock device.

LOCK (Normal parking position) (0)

The ignition key can only be removed when the switch is in this position.

OFF (1)

The engine can be turned off without locking the steering wheel.

The ignition lock is designed so that the key cannot be turned to LOCK and removed until the selector lever is moved to the P (Park) position.

ACC (Accessories) (2)

This position activates electrical accessories

such as the radio when the engine is not running.

ON (Normal operating position) (3)

This position turns on the ignition system and the electrical accessories.

START (4)

This position activates the starter motor, starting the engine.

INFINITI VEHICLE IMMOBILIZER SYSTEM

The INFINITI Vehicle Immobilizer System will not allow the engine to start without the use of the registered INFINITI Vehicle Immobilizer System key.

If the engine fails to start using the registered INFINITI Vehicle Immobilizer System key, it may be due to interference caused by another INFINITI Vehicle Immobilizer System key, an automated toll road device or an automated payment device on the key ring. Restart the engine using the following procedures:

1. Leave the ignition switch in the ON position for approximately 5 seconds.
2. Turn the ignition switch to the OFF or LOCK position and wait approximately 10 seconds.

3. Repeat step 1 and 2 again.

4. Restart the engine while holding the device (which may have caused the interference) separate from the registered INFINITI Vehicle Immobilizer System key.

If this procedure allows the engine to start, INFINITI recommends placing the registered INFINITI Vehicle Immobilizer System key on a separate key ring to avoid interference from other devices.

IGNITION KNOB (models with the Intelligent Key System)

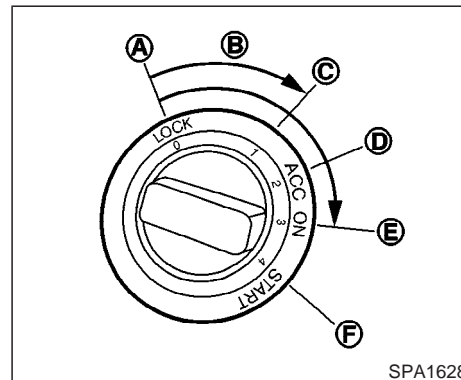

The ignition lock is designed so that the ignition knob cannot be turned to LOCK and removed until the selector lever is moved to the P (Park) position.

When turning the ignition knob, make sure the selector lever is in the P position.

If the selector lever is not returned to the P position, the ignition knob cannot be moved toward LOCK.

When the ignition knob cannot be turned toward the LOCK position while keeping the Intelligent Key, proceed as follows:

1. Move the selector lever into the P position.

2. Turn the ignition knob slightly in the ON direction.
3. Turn the key toward the LOCK position.

The selector lever can be moved from P position if the ignition knob is in the ON position and the foot brake pedal is depressed.

There is an OFF position in between LOCK and ACC, although it does not show on the lock cylinder. When the ignition is in OFF the steering wheel is not locked.

In order for the steering wheel to be locked, it must be turned about 1/6 of a turn counter-clockwise from the straight up position.

To lock the steering wheel, turn the ignition knob to the LOCK position. To unlock the steering wheel, push the ignition knob in and turn it gently while rotating the steering wheel slightly right and left.

If the battery of the vehicle equipped with the Intelligent Key system is discharged, the ignition knob cannot be turned from the LOCK position, even using the mechanical key or valet key.



WARNING

Never turn the ignition knob to the LOCK position while driving. The steering wheel will lock. This may cause the driver to lose control of the vehicle and could result in serious vehicle damage and/or personal injury.

IGNITION KNOB POSITIONS

Push in the ignition knob to the (B) range when you turn it.

LOCK (Normal parking position):

The ignition knob can only be locked in the (A) position.

The ignition knob will be unlocked when it is pushed in, and turned to the ACC position (D) while carrying the Intelligent Key.

ACC (Accessories) (D):

This position activates electrical accessories such as the radio, when the engine is not running.

ON (Normal operating position) (E):

This position turns on the ignition system and electrical accessories.

START (F):

This position starts the engine. As soon as the engine has started, release the knob immediately. It will automatically return to the ON position.

For important safety information, see “Ignition switch” in the “Starting and driving” section.

The ignition knob cannot be turned back to the LOCK position unless the shift lever is in P position. (It can be turned to only (C))



CAUTION

Do not leave the vehicle with the ignition knob in ACC or ON positions when the engine is not running for an extended period. This can discharge the battery.

INFINITI VEHICLE IMMOBILIZER SYSTEM

The INFINITI Vehicle Immobilizer System will not allow the engine to start without the use of

the registered INFINITI Vehicle Immobilizer System key.

If the engine fails to start using the registered INFINITI Vehicle Immobilizer System key, it may be due to interference caused by another INFINITI Vehicle Immobilizer System key, an automated toll road device or an automated payment device on the key ring. Restart the engine using the following procedures:

1. Leave the ignition switch in the ON position for approximately 5 seconds.
2. Turn the ignition switch to the OFF or LOCK position and wait approximately 10 seconds.
3. Repeat step 1 and 2 again.
4. Restart the engine while holding the device (which may have caused the interference) separate from the registered INFINITI Vehicle Immobilizer System key.

If this procedure allows the engine to start, INFINITI recommends placing the registered INFINITI Vehicle Immobilizer System key on a separate key ring to avoid interference from other devices.

BEFORE STARTING THE ENGINE

- Make sure the area around the vehicle is clear.
- Maintenance items should be checked periodically, e.g., each time you check engine oil.
- Check that all windows and lights are clean.
- Visually inspect tires for their appearance and condition. Also, check tires for proper inflation.
- Lock all doors.
- Position seat and adjust head restraints.
- Adjust inside and outside mirrors.
- Fasten seat belts and ask all passengers to do likewise.
- Check the operation of warning lights when key is turned to the ON (3) position.

STARTING THE ENGINE

1. Apply the parking brake.
2. Move the selector lever to P (Park) or N (Neutral). (P preferred.)

The starter is designed not to operate if the selector lever is in one of the driving positions.

3. Crank the engine **with your foot off the accelerator pedal** by turning the ignition key to START. Release the key when the engine starts. If the engine starts, but fails to run, repeat the above procedure.
- If the engine is very hard to start in extremely cold weather or when restarting, depress the accelerator pedal a little (approximately 1/3 to the floor) and hold it then crank the engine. Release the key and the accelerator pedal when the engine starts.
 - If the engine is very hard to start because it is flooded, depress the accelerator pedal all the way to the floor and hold it. Crank the engine for 5 to 6 seconds. After cranking the engine, release the accelerator pedal. Crank the engine **with your foot off the accelerator pedal** by turning the ignition key to START. Release the key when the engine starts. If the engine starts, but fails to run, repeat the above procedure.



CAUTION

Do not operate the starter for more than 15 seconds at a time. If the engine does not start, turn the key off and wait 10 seconds before cranking again, otherwise the starter could be damaged.

4. Warm-up

Allow the engine to idle for at least 30 seconds after starting. Do not race the engine while warming it up. Drive at moderate speed for a short distance first, especially in cold weather.

In cold weather, keep the engine running for a minimum of 2 to 3 minutes before shutting it off. Starting and stopping the engine over a short period of time may make the vehicle more difficult to start.

DRIVING THE VEHICLE

AUTOMATIC TRANSMISSION

5-speed automatic transmission

The automatic transmission in your vehicle is electronically controlled by a transmission control module to produce maximum power and smooth operation.

Shown on the following pages are the recommended operating procedures for this transmission. Follow these procedures for maximum vehicle performance and driving enjoyment.

Starting the vehicle

After starting the engine, fully depress the foot brake pedal and push the selector lever button before shifting the selector lever to the R (Reverse), N (Neutral), D (Drive) or Manual shift mode position. Be sure the vehicle is fully stopped before attempting to shift the selector lever.

This automatic transmission model is designed so that the foot brake pedal must be depressed before shifting from P (Park) to any drive position while the ignition switch is ON.

The selector lever cannot be moved out of P (Park) position and into any of the other gear positions if the ignition key is turned

to the LOCK, OFF or ACC position or if the key is removed from the switch.

1. Keep the foot brake pedal depressed and push the selector lever button to shift into a driving gear.
2. Release the parking brake and foot brake, then gradually start the vehicle in motion.



WARNING

- **Do not depress the accelerator pedal while shifting from P (Park) or N (Neutral) to R (Reverse), D (Drive) or manual shift mode. Always depress the brake pedal until shifting is completed. Failure to do so could cause you to lose control and have an accident.**
- **Cold engine idle speed is high, so use caution when shifting into a forward or reverse gear before the engine has warmed up.**
- **On slippery roads, do not downshift. This may cause a loss of control.**
- **Never shift to P (Park) or R (Reverse)**



while vehicle is moving forward. Never shift to P (Park) or D (Drive) while vehicle is moving rearward. These could cause an accident.

CAUTION

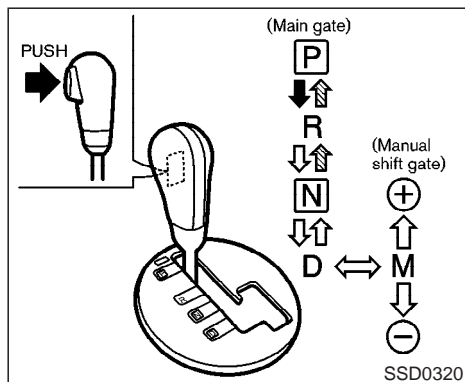
When stopping the vehicle on an uphill grade, do not hold the vehicle by depressing the accelerator pedal. The foot brakes should be used for this purpose.



To move the selector lever,

-  : Push the button while depressing the brake pedal,
-  : Push the button,
-  : Just move the selector lever.

Shifting

After starting the engine, fully depress the brake pedal and shift the selector lever from P (Park) to R (Reverse), N (Neutral), D (Drive), or Manual shift mode position.

Push the button to shift into P (Park) or R (Reverse). All other positions can be selected without pushing the button.

WARNING

Apply the parking brake if the selector lever is in any position while the engine is not running. Failure to do so could cause the vehicle to move unexpectedly or roll away and result in serious personal injury and/or property damage.

If the key is turned to OFF or ACC for any reason while the vehicle is in R (Reverse), N (Neutral), or any D (Drive) position, the key cannot be turned to LOCK and be removed from the ignition switch. Move the selector lever to P (Park) position, then the key can be turned to LOCK.

P (Park):

Use this selector position when the vehicle is parked or when starting the engine. Make sure the vehicle is completely stopped. **The brake pedal must be depressed and the selector lever button pushed in to move the selector lever from N (Neutral) or any drive position to P (Park).** Apply the parking brake. When parking on a hill, apply the parking brake first, then move the lever to the P (Park) position.



CAUTION

Use this position only when the vehicle is completely stopped.

R (Reverse):

Use this position to back up. Always be sure the vehicle is completely stopped before selecting R (Reverse). **The brake pedal must be depressed and the selector lever button pushed in to move the selector lever from P (Park), N (Neutral) or any drive position to R (Reverse).**

N (Neutral):

Neither forward nor reverse gear is engaged. The engine can be started in this position. You may shift to N (Neutral) and restart a stalled engine while the vehicle is moving.

D (Drive):

Use this position for all normal forward driving.

Manual shift mode

When the selector lever is shifted from D to the manual shift gate with the vehicle stopped or while driving, the transmission enters the

5-14 Starting and driving

manual shift mode. Shift range can be selected manually.

In the manual shift mode, the shift range is displayed on the position indicator in the meter.

Shift ranges up or down one by one as follows:

$M_1 \begin{matrix} \rightarrow \\ \leftarrow \end{matrix} M_2 \begin{matrix} \rightarrow \\ \leftarrow \end{matrix} M_3 \begin{matrix} \rightarrow \\ \leftarrow \end{matrix} M_4 \begin{matrix} \rightarrow \\ \leftarrow \end{matrix} M_5$

M_5 (5th):

Use this position for all normal forward driving.

M_4 (4th):

For driving up or down long slopes where engine braking would be advantageous.

M_3 (3rd) and M_2 (2nd):

Use for hill climbing or engine braking on downhill grades.

M_1 (1st):

Use this position when climbing steep hills slowly or driving slowly through deep snow, sand or mud, or for maximum engine braking on steep downhill grades.

- Remember not to drive at high speeds for extended periods of time in lower than M_4 range. This reduces fuel economy.
- When shifting up, move the selector lever to

the + (up) side. (Shifts to higher range.)

- When shifting down, move the selector lever to the – (down) side. (Shifts to lower range.)
- Moving the selector lever to the same side twice will shift the ranges in succession. However, if this motion is rapidly done, the second shifting may not be completed properly.
- **In the manual shift mode, the transmission automatically shifts down to 1st gear before the vehicle comes to a stop. When accelerating again, it is necessary to shift up to the desired range.**
- When canceling the manual shift mode, return the selector lever to the D position. The transmission returns to the normal driving mode.
- **In the manual shift mode, the transmission may not shift to the selected gear. This helps maintain driving performance and reduces the chance of vehicle damage or loss of control.**

Accelerator downshift

— In D position —

For passing or hill climbing, fully depress the accelerator pedal to the floor. This shifts the

transmission down into the lower gear, depending on the vehicle speed.

Fail-safe

When the fail-safe operation occurs, the next time the key is turned to the ON position, the ^{AT} _{CHECK} light will blink for approximately 8 seconds after coming on for 2 seconds. While the vehicle can be driven under these circumstances please note that the gears in the automatic transmission will be locked in 4th gear.

If the vehicle is driven under extreme conditions, such as excessive wheel spinning and subsequent hard braking, the fail-safe system may be activated. This will occur even if all electrical circuits are functioning properly. In this case, turn the ignition key OFF and wait for 3 seconds. Then turn the key back to the ON position. The vehicle should return to its normal operating condition. If it does not return to its normal operating condition, have your INFINITI dealer check the transmission and repair if necessary.

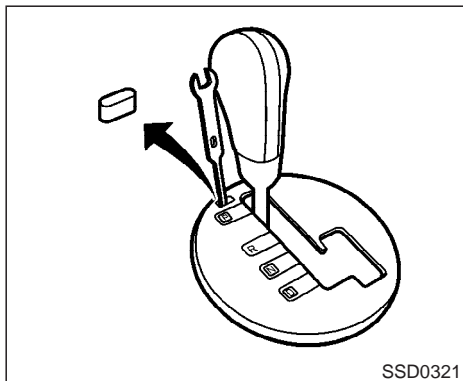

Shift lock release

If the battery charge is low or discharged, the selector lever may not be moved from the P (Park) position even with the brake pedal depressed.

To move the selector lever, apply the parking brake, depress the brake pedal, and push the shift lock release button. The selector lever can be moved to N (Neutral). This allows the vehicle to be moved if the battery is discharged.

If the lever cannot be moved out of P (Park), have your INFINITI dealer check the automatic transmission system as soon as possible.

PARKING BRAKE

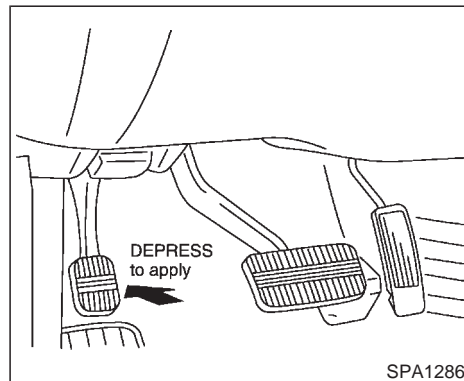

To apply: Fully depress the parking brake pedal.

To release:

1. Firmly apply the foot brake.
2. Depress the parking brake pedal and the parking brake will be released.
3. Before driving, be sure the brake warning light goes out.

CRUISE CONTROL



WARNING

- Be sure the parking brake is fully released before driving. Failure to do so can cause brake failure and lead to an accident.
- Do not release the parking brake from outside the vehicle.
- Do not use the gear shift in place of the parking brake. When parking, be sure the parking brake is fully engaged.
- Do not leave children unattended in a vehicle. They could release the parking brake and cause an accident.



WARNING

Do not use the cruise control when driving under the following conditions:

- it is not possible to keep the vehicle at a set speed.
- in heavy traffic or in traffic that varies in speed.
- on winding or hilly roads.
- on slippery roads (rain, snow, ice, etc.).
- in very windy areas.

Doing so could cause a loss of vehicle control and result in an accident.

- If the SET indicator light blinks, turn the cruise control main switch off and have the system checked by your INFINITI dealer.
- The SET indicator light may blink when the cruise control main switch is turned on while pushing the RES/ACCEL, COAST/SET, or CANCEL switch (located on the steering wheel). To properly set the cruise control system, perform the preceding steps in the order indicated.

PRECAUTIONS ON CRUISE CONTROL

- If the cruise control system malfunctions, it cancels automatically. The SET indicator light on the meter panel then blinks to warn the driver.
- If the engine coolant temperature becomes excessively high, the cruise control system will be canceled automatically.

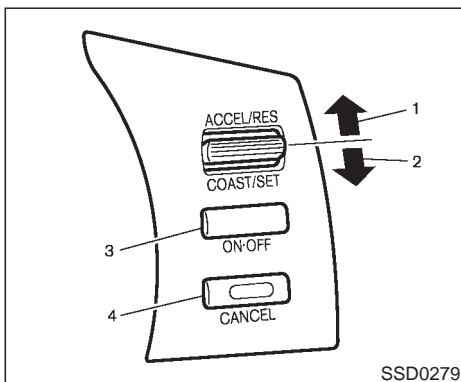

1. RESUME or ACCEL switch
2. COAST or SET switch
3. ON/OFF switch
4. CANCEL switch

CRUISE CONTROL OPERATIONS

The cruise control allows driving at a speed between 25 to 89 MPH (40 to 144 km/h) without keeping your foot on the accelerator pedal.

To turn on the cruise control, push the main switch on. The CRUISE indicator light on the meter panel will come on.

To set at cruising speed, accelerate your vehicle to the desired speed, push the COAST/SET switch and release it. (The SET indicator light will come on.) Take your foot off the accelerator pedal. Your vehicle will maintain the set speed.

- **To pass another vehicle,** depress the accelerator pedal. When you release the pedal, the vehicle will return to the previously set speed.
- The vehicle may not maintain the set speed when going up or down steep hills. If this happens, drive without the cruise control.

To cancel the preset speed, follow either of these three methods:

- a) Push the cancel switch; The SET indicator light will go out.
 - b) Tap the brake pedal; The SET indicator light will go out.
 - c) Turn the main switch off. Both the CRUISE indicator and SET indicator lights will go out.
- If you depress the brake pedal while pushing the RES/ACCEL set switch and reset at the cruising speed, turn the main switch off once and then turn it on again.
 - The cruise control will automatically be can-

celled if the vehicle slows down below approximately 8 MPH (13 km/h).

- Move the selector lever to N (Neutral) position. The SET indicator light will go out.

To reset at a faster cruising speed, use one of the following three methods:

- a) Depress the accelerator pedal. When the vehicle attains the desired speed, push and release the COAST/SET switch.
- b) Push and hold the RES/ACCEL set switch. When the vehicle attains the speed you desire, release the switch.
- c) Push, then quickly release the RES/ACCEL set switch. Each time you do this, the set speed will increase by about 1 MPH (1.6 km/h).

To reset at a slower cruising speed, use one of the following three methods:

- a) Lightly tap the brake pedal. When the vehicle attains the desired speed, push the COAST/SET switch and release it.
- b) Push and hold the COAST/SET switch. Release the switch when the vehicle slows down to the desired speed.
- c) Push, then quickly release the COAST/SET switch. Each time you do this, the set

speed will decrease by about 1 MPH (1.6 km/h).

To resume the preset speed, push and release the RES/ACCEL set switch. The vehicle will resume the last set cruising speed when the vehicle speed is over 25 MPH (40 km/h).

INTELLIGENT CRUISE CONTROL SYSTEM (if so equipped)

The Intelligent Cruise Control (ICC) system automatically maintains a selected distance from the vehicle in front of you according to that vehicle's speed, or at the set speed, if the road ahead is clear.

The ICC function has two cruise control modes: Vehicle-to-vehicle distance control mode for maintaining a selected distance between a vehicle, and a conventional (fixed speed) cruise control mode for cruising at preset speeds.



WARNING

Always drive carefully and attentively when using either cruise control mode. Read and understand the Owner's Manual thoroughly before using the cruise control. To avoid serious injury or death, do not rely on the system to prevent accidents or to control the vehicle's speed in emergency situations. Do not use cruise control except in appropriate road and traffic conditions.

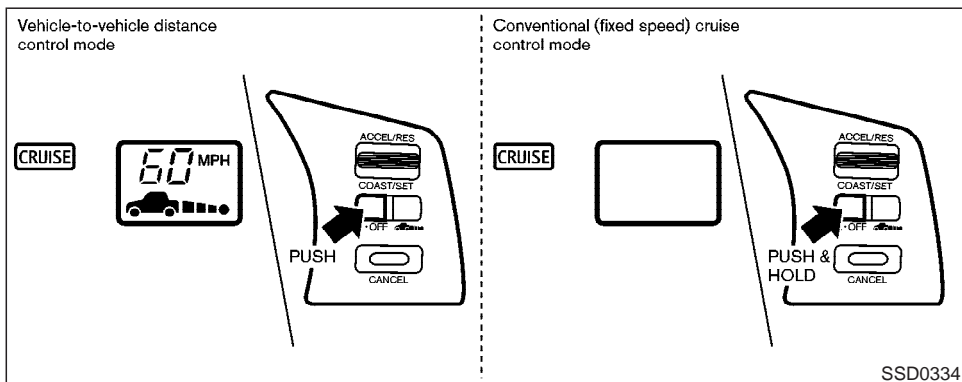

SSD0334

HOW TO CHANGE THE INTELLIGENT CRUISE CONTROL MODE

When you push the ON/OFF switch, you can choose the cruise control mode between the vehicle-to-vehicle distance control mode and the conventional (fixed speed) cruise control mode.

When you push the ON/OFF switch quickly, the vehicle-to-vehicle distance control mode is activated.

To choose the conventional (fixed speed) cruise control mode, push and hold the

ON/OFF switch for longer than about 1.5 seconds.

Once a control mode is chosen and activates, it cannot be changed to the other cruise control mode. To change the mode, push the ON/OFF switch once, then turn on the system again.



WARNING

- In the conventional (fixed speed) cruise control mode, a warning buzzer does not sound to warn you if

you are too close to the vehicle ahead, as neither the presence of the vehicle ahead nor the vehicle-to-vehicle distance is detected.

- Pay special attention to the distance between your vehicle and the vehicle ahead of you or a collision could occur.
- Always confirm the setting in the Intelligent Cruise Control system display.

For the vehicle-to-vehicle distance control mode, see the following description. For the conventional (fixed speed) cruise control mode, see page 5-33.

VEHICLE-TO-VEHICLE DISTANCE CONTROL MODE

In the vehicle-to-vehicle distance control mode, the Intelligent Cruise Control (ICC) system automatically maintains a selected distance from the vehicle in front of you according to that vehicle's speed, or at the set speed, if the road ahead is clear.

With ICC, the driver can maintain the same

speed as other vehicles without the constant need to adjust the speed as you would with a normal cruise control system.

The system is intended to enhance the operation of the vehicle when following another vehicle traveling in the same lane and direction. If the distance sensor detects a slower moving vehicle ahead of you, the system will reduce your speed so that you follow the vehicle in front of you at the selected distance. The system automatically controls the throttle and applies the brakes (up to 25% of vehicle braking power) if necessary.

The detection range of the sensor is approximately 390 ft (120 m) ahead.



WARNING

- **This system is only an aid to assist the driver and is not a collision warning or avoidance device. It is the driver's responsibility to stay alert, drive safely and be in control of the vehicle at all times.**
- **The system is primarily intended for use on straight, dry, open roads with light traffic. It is not advisable to use**

the system in city traffic or congested areas.

- **This system will not adapt automatically to road conditions. This system should be used in evenly flowing traffic. Do not use the system on roads with sharp curves, or on icy roads, in heavy rain or in fog.**

The distance sensor will not detect under most conditions:

- Stationary and slow moving vehicles
- Pedestrians or objects in the roadway
- Oncoming vehicles in the same lane
- Motorcycles or scooters traveling offset in the travel lane

This system will not automatically brake the vehicle to a stop.

The system will cancel and a warning buzzer will sound if the speed falls below approximately 20 MPH (32 km/h). Also, the system will be disengaged below the 20 MPH (32 km/h) cut-off speed or over the maximum set speed.

The following items are controlled when the selector lever is in the D (Drive) position except in the manual shift mode.

- When there are no vehicles ahead, the vehicle with this system maintains the speed set by the driver. The driver can set the speed between approximately 25 and 90 MPH (40 and 144 km/h).
- When there is a vehicle ahead, the ICC system changes vehicle speed between approximately 20 MPH (32 km/h) and the set speed to match the speed of the vehicle ahead and maintain the driver selected distance between vehicles.
- When the vehicle ahead disappears, the vehicle with this system accelerates up to and maintains the set speed.



WARNING

- **As there is a performance limit to the distance control function, never rely solely on the Intelligent Cruise Control system. This system does not correct careless, inattentive or absent-minded driving, or overcome poor visibility in rain, fog, or other**

bad weather. Decelerate the vehicle speed by depressing the brake pedal, depending on the distance to the vehicle ahead and the surrounding circumstances in order to maintain a safe distance between vehicles.

- Although the brake operation is controlled by the system, the system does not automatically stop the vehicle. If the vehicle speed falls below approximately 20 MPH (32 km/h), the Intelligent Cruise Control system is automatically canceled and a warning buzzer sounds. (The brake control is also canceled.)
- The system may not detect the vehicle in front of you in certain road or weather conditions. To avoid accidents, never use the Intelligent Cruise Control system under the following conditions:
 - On roads where the traffic is heavy or there are sharp curves
 - On slippery road surfaces such as on ice or snow, etc.

- During bad weather (rain, fog, snow, etc.)
(When the windshield wiper is operated at the low speed (LO) or high speed (HI) position, the Intelligent Cruise Control system is automatically canceled.)
- When strong light (for example, at sunrise or sunset) is directly shining on the front of the vehicle.
- When rain, snow or dirt adhere to the system sensor.
- On steep downhill roads (the vehicle may go beyond the set vehicle speed and frequent braking may result in overheating the brakes).
- On repeated uphill and downhill roads.
- When traffic conditions make it difficult to keep a proper distance between vehicles because of frequent acceleration or deceleration.

- If you are towing a trailer, the system may not detect a vehicle ahead. Do not use the Intelligent Cruise Control system.
- In some road or traffic conditions, a vehicle or object can unexpectedly come into the sensor detection zone and cause automatic braking. You may need to control the distance from other vehicles using the accelerator pedal. Always stay alert and avoid using the ICC system when it is not recommended in this section.

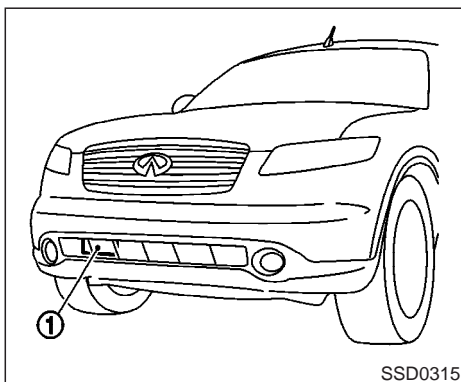

Driving with intelligent cruise control system

Always pay attention to the operation of the vehicle and be ready to manually control the proper following distance. The Intelligent Cruise Control (ICC) system may not be able to maintain the selected distance between vehicles (following distance) or selected vehicle speed under some circumstances.

The ICC system uses a sensor ① located on the front of the vehicle to detect vehicles ahead. The sensor generally detects the signals returned from the reflectors on a vehicle ahead. The ICC system may not be able to

maintain the selected distance if the sensor cannot detect the reflector from the vehicle ahead when:

- the reflector is positioned high on the vehicle (trailer, etc.).
- the reflector is covered with dirt, snow and road spray.
- snow or road spray from other vehicles reduces the sensor's visibility.
- dense exhaust or other smoke (black smoke) from other vehicles reduces the sensor's visibility.
- if the reflector on the vehicle ahead is missing, damaged or covered.
- if excessively heavy baggage is loaded in the rear seat or the trunk of your vehicle.
- if your vehicle tows a trailer, etc..

The ICC system is designed to automatically detect when the sensor is dirty or obstructed. If dirt is detected on the sensor, the system is automatically canceled. If the sensor is covered with ice, a transparent or translucent vinyl bag, etc., the ICC system may not detect them. If so, the ICC system may not cancel and may not be able to maintain the selected following distance. Clean the sensor regularly.

The ICC system is designed to maintain a selected distance and match the speed of a slower vehicle ahead; the system decelerates the vehicle as necessary. However, the ICC system can only apply up to 25% of the vehicles total braking power. Because of this, the ICC system should only be used when traffic conditions allow vehicle speeds to remain fairly constant or vehicle speeds change gradually. If a vehicle moves into the lane ahead or if a vehicle ahead rapidly decelerates, the distance between vehicles may become closer because the ICC system cannot decelerate the vehicle quickly enough. If this occurs, the ICC system will sound a warning buzzer and blink the system display to notify the driver to take necessary action. Refer to "Approach warning" later in this section.

The ICC system does not control vehicle speed or warn you when you approach stationary and slow moving vehicles. You must pay attention to vehicle operation to maintain proper distance from vehicles ahead when approaching toll gates or traffic jams.

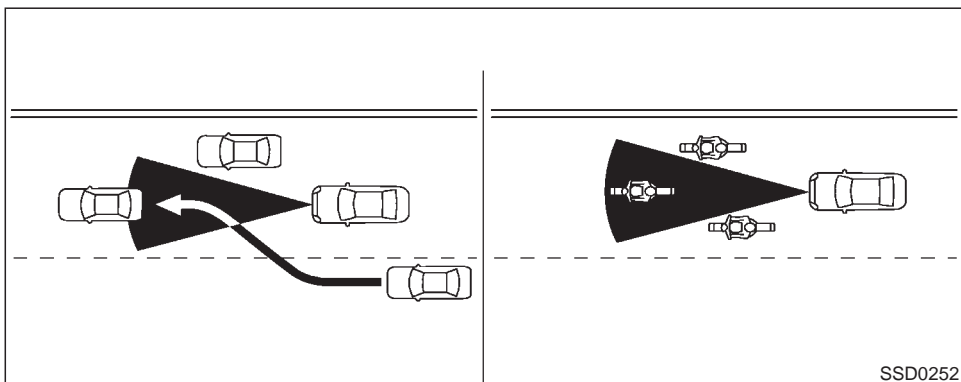

The detection zone of the ICC sensor is limited. A vehicle ahead must be in the detection zone for the ICC to maintain the selected distance and to match the speed of a vehicle ahead.

A vehicle ahead may be outside the detection zone due to its position in the lane. Motorcycles and scooters may not be detected in the lane ahead if they are traveling offset from the centerline of the lane. A vehicle that is changing lanes ahead may be outside the detection zone until it is almost completely in the lane. **If this occurs, the ICC system may warn you by blinking the system indicator and sounding the buzzer. The driver may have**

to manually control the proper following distance.

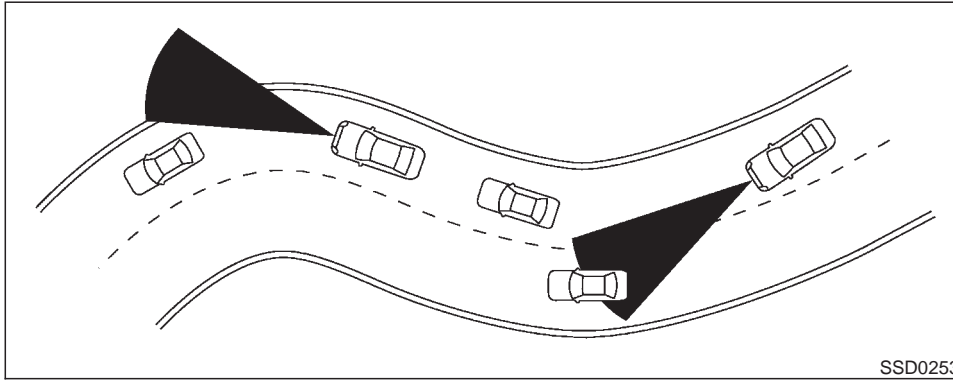

When driving on some roads, the ICC sensor may detect vehicles in a different lane, or may temporarily not detect a vehicle ahead. This may cause the ICC system to decelerate or accelerate the vehicle. These conditions could happen on winding roads, hilly roads, entering or exiting a curve, narrow roads or in road construction areas. Additionally, the detection of vehicles can be affected by vehicle operation (steering maneuver or driving position in the lane) or vehicle condition (for example, if a vehicle is being driven with some damage). **In such situations the ICC system indicator and buzzer may warn you unexpectedly. You will then have to manually control the**

proper distance ahead of your vehicle.

5-24 Starting and driving

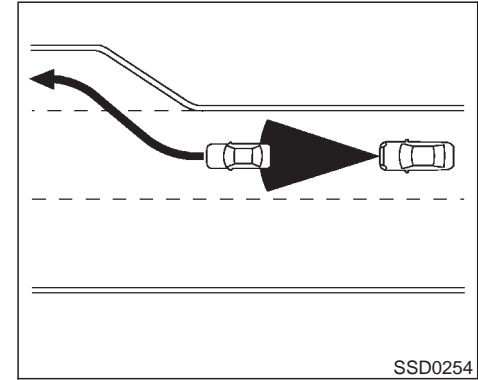

If you are driving on the freeway at a set speed and come upon a slower vehicle ahead, the ICC will attempt to match that vehicle's speed and maintain a selected following distance. If the vehicle ahead changes lanes or exits the freeway, the ICC system will accelerate the vehicle to match the set speed. Pay attention to the driving operation to maintain control of the vehicle as it accelerates to the set speed.

The vehicle may not maintain the set speed on winding or hilly roads. If this happens, drive without the ICC system.

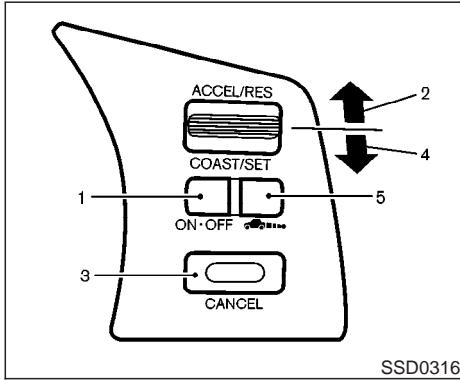

Intelligent cruise control switch

The system is operated by a master ON/OFF switch and four control switches, all mounted on the steering wheel.

1. ON/OFF switch:
Master switch to activate the system
2. ACCELERATE/RESUME switch:
Resumes set speed or increases speed incrementally.
3. CANCEL switch:
Deactivates the system without erasing the set speed.

4. COAST/SET switch:
Sets desired cruise speed, reduces speed incrementally.
5. DISTANCE switch:
Changes the following distance from; Maximum, Intermediate, Minimum.

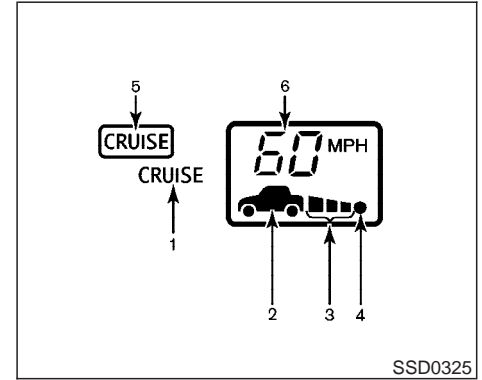

Intelligent cruise control system display

The display is located under the tachometer.

1. Intelligent Cruise Control system warning light (Orange)

The light comes on if there is a malfunction in the ICC system.

2. Vehicle ahead detection indicator

Indicates whether it detects a vehicle in front of you.

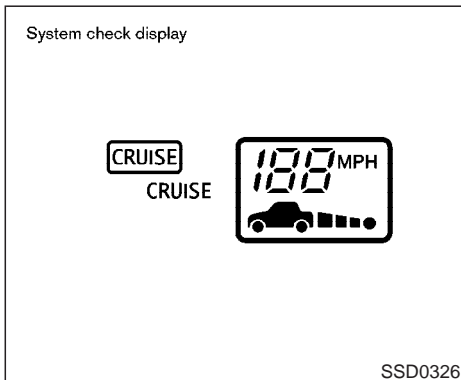

comes on as illustrated to check for a burned-out bulb, and it turns off when the engine is started.

3. Set distance indicator

Displays the selected distance between vehicles set with the DISTANCE switch.

4. Indicates your vehicle

5. ON/OFF switch indicator light (Green)

Indicates that the ON/OFF switch is ON.

6. Set vehicle speed indicator

Indicates the set vehicle speed.

For Canadian models, the speed will be indicated by km/h.

When the key switch is turned ON, the display

5-26 Starting and driving

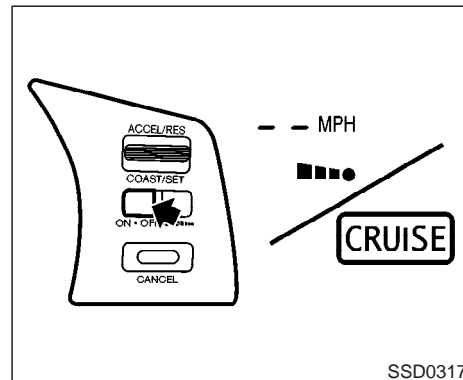

Operating vehicle-to-vehicle distance control mode

To turn on the cruise control, push the ON/OFF switch on. The cruise indicator light, set distance indicator and set vehicle speed indicator come on, and they are on a standby state for setting.



CAUTION

To avoid accidentally engaging cruise control, make sure to turn the ON/OFF

switch is off when not using the Intelligent Cruise Control.

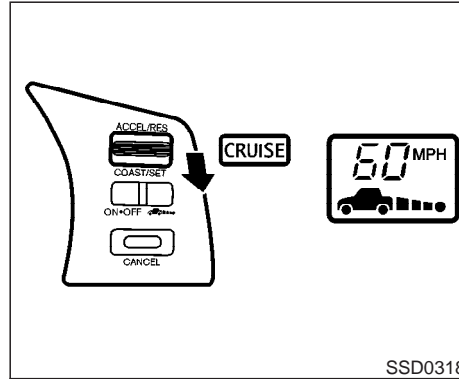

To set cruising speed, accelerate your vehicle to the desired speed, push the COAST/SET switch and release it. (Vehicle ahead detection indicator, set distance indicator and set vehicle speed indicator come on.) Take your foot off the accelerator pedal. Your vehicle will maintain the set speed.

The Intelligent Cruise Control system cannot be set under the following conditions even if the COAST/SET switch is pushed.

- When traveling outside the 25 to 90 MPH (40 to 144 km/h) speed range
- When the selector lever is not in the D

(Drive) position, including the manual shift mode.

- While the vehicle is being braked by the driver
- When pressing the ACCEL/RES switch without there being a set speed in memory
- When the windshield wipers are switched to Low or High
- When the parking brake is applied.
- When the Vehicle Dynamic Control (VDC) system is switched off.

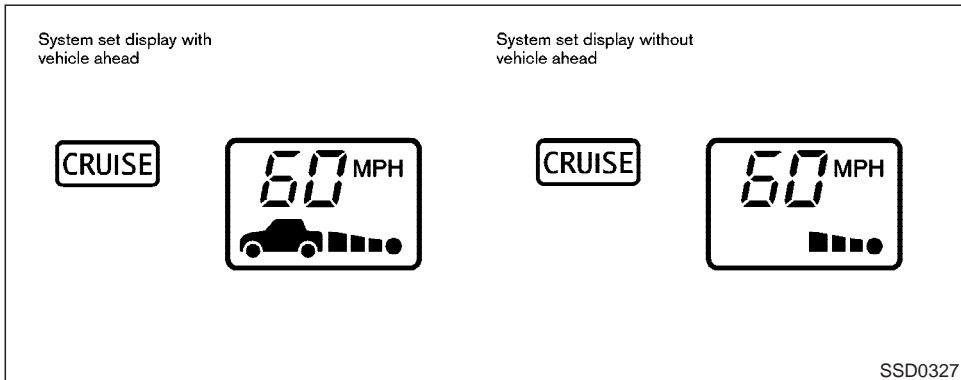

System operation



WARNING

Normally when controlling the distance to a vehicle ahead, this system automatically accelerates or decelerates your vehicle according to the speed of the vehicle ahead. Depress the accelerator or brake pedal, however, to properly accelerate or decelerate your vehicle when acceleration is required for a

lane change or when deceleration is required to maintain a safe distance to the vehicle ahead due to its sudden deceleration or if a vehicle cuts in. Always stay alert when using the ICC system.

The driver sets the desired vehicle speed based on the road conditions. The ICC system maintains the set vehicle speed, similar to standard cruise control, as long as no vehicle is detected in the lane ahead.

The ICC system displays the set speed.

Vehicle detected ahead:

When a vehicle is detected in the lane ahead, the ICC system decelerates the vehicle by controlling the throttle and applying the brakes to match the speed of a slower vehicle ahead. The system then controls the vehicle speed based on the speed of the vehicle ahead to maintain a driver selected distance.

The stoplights of the vehicle come on and the brake pedal depresses when braking is performed by the ICC system.



CAUTION

Never place your foot under the brake pedal, when the brake is operated by the Intelligent Cruise Control system. You may get your foot caught in the pedal.

When a vehicle ahead is detected, the vehicle ahead detection indicator comes on. The ICC system will also display the set speed and selected distance.

Vehicle ahead not detected:

When a vehicle is not longer detected ahead, the ICC system gradually accelerates your vehicle to resume the previously set vehicle

speed. The ICC system then maintains the set speed.

When a vehicle is no longer detected the vehicle ahead detection indicator turns off.

If a vehicle ahead appears during acceleration to the set vehicle speed or any time the ICC system is in operation, the system recontrols the distance to the vehicle.

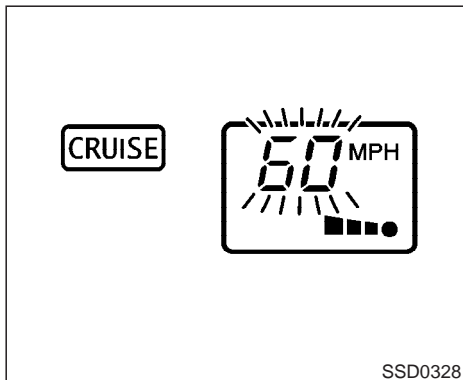

To pass another vehicle, depress the accelerator pedal and steer the vehicle around the vehicle ahead. The set speed indicator will flash when the vehicle speed exceeds the set speed. The vehicle detect indicator will turn off when the area ahead of the vehicle is open. When the pedal is released, the vehicle will return to the previously set speed.

Although your vehicle may be at the set vehicle speed based on ICC system control, depress the accelerator pedal when it is necessary to accelerate your vehicle rapidly.

How to change the set vehicle speed

To cancel the preset speed, use any of these methods:

- Push the CANCEL switch. The set vehicle speed indicator will go out.
- Tap the brake pedal. The set vehicle speed indicator will go out.
- Turn the ON/OFF switch off. Both the ON/OFF switch indicator and set vehicle speed indicator will go out.

To reset at a faster cruising speed, use one of the following methods:

- Depress the accelerator pedal. When the vehicle attains the desired speed, push and release the COAST/SET switch.
- Push and hold the ACCEL/RES switch. The set vehicle speed will increase by approximately 5 MPH (5 km/h for Canada).
- Push, then quickly release the ACCEL/RES switch. Each time you do this, the set speed will increase by approximately 1 MPH (1 km/h for Canada).

To reset at a slower cruising speed, use one of the following methods:

- Lightly tap the brake pedal. When the vehicle attains the desired speed, push the COAST/SET switch and release it.
- Push and hold the COAST/SET switch. The set vehicle speed will decrease by approximately 5 MPH (5 km/h for Canada).
- Push, then quickly release the COAST/SET switch. Each time you do this, the set speed will decrease by approximately 1 MPH (1 km/h for Canada).

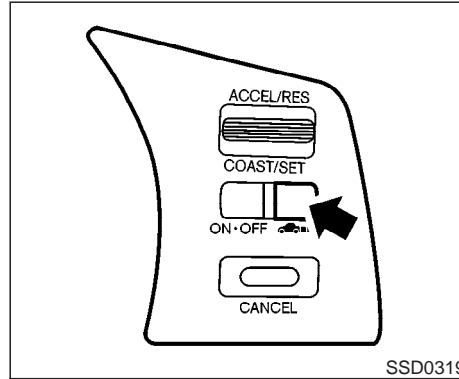

To resume the preset speed, push and release the ACCEL/RES switch. The vehicle will resume the last set cruising speed when the vehicle speed is over 25 MPH (40 km/h).



How to change the set distance to the vehicle ahead

The distance to the vehicle ahead can be selected at any time depending on the traffic conditions.

Each time the DISTANCE switch is pressed, the set distance will change to long, medium, short and back to long again in that sequence.

Distance	Display	Approximate distance at 60 MPH (100 km/h) [ft (m)]
Long		195 (60)
Middle		130 (40)
Short		90 (30)

SSD0329

- The distance to the vehicle ahead will change according to the vehicle speed. The higher the vehicle speed, the longer the distance.
- If the engine is stopped, the set distance becomes “long”. (Each time the engine is

started, the initial setting becomes long.)

Approach warning

If your vehicle comes closer to the vehicle ahead due to large deceleration of that vehicle or if another vehicle cuts in, the system warns

the driver with the buzzer and ICC system display. Decelerate by depressing the brake pedal to maintain a safe vehicle distance if:

- The buzzer sounds.
- The vehicle ahead detection and set distance indicator blink.



WARNING

Do not use the Intelligent Cruise Control system when traffic conditions cause the buzzer to sound frequently.

The warning buzzer may not sound in some cases when there is a short distance between vehicles. Some examples are:

- When the vehicles are traveling at the same speed and the distance between vehicles is not changing.
- When the vehicle ahead is traveling faster and the distance between vehicles is increasing.
- When the accelerator pedal is depressed, overriding the system.
- When a vehicle cuts in near your vehicle.

The warning buzzer will not sound when your

vehicle approaches vehicles that are parked or moving slowly.

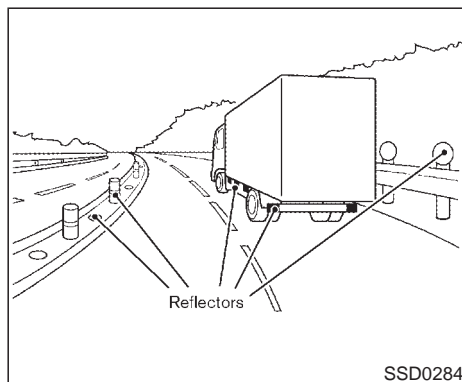

NOTE:

The approach warning chime may sound and the system display may blink when the ICC sensor detects some reflectors which are fitted on vehicles in other lanes or on the side of the road. This may cause the ICC system to decelerate or accelerate the vehicle. The ICC sensor may detect these reflectors when the vehicle is driven on winding roads, hilly roads or when entering or exiting a curve. The ICC sensor may also detect reflectors on narrow roads or in road construction zones. In these cases you will have to manually control the proper distance ahead of your vehicle.

Also, the sensor sensitivity can be affected by the vehicle operation (steering maneuver or driving position in the lane) or the traffic condition (for example, if a vehicle is being driven with same damage).

Automatic cancellation

A buzzer sounds under the following conditions and the control is automatically canceled.

- When the vehicle speed falls below approximately 20 MPH (32 km/h)
- When the selector lever is shifted to a position other than D (Drive), including the manual shift mode
- When the wiper is operated at low speed (LO) or high speed (HI)
- When the parking brake is applied
- When the VDC is turned off
- When the VDC operates

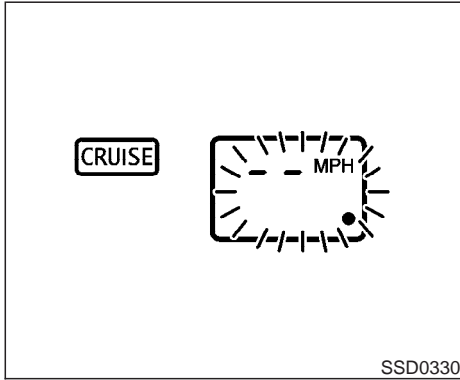

shining on the front of the vehicle

Action to take:

When the conditions listed above are no longer present, turn the system off using the Intelligent Cruise Control ON/OFF Switch. Turn the ICC system back on to use the system.

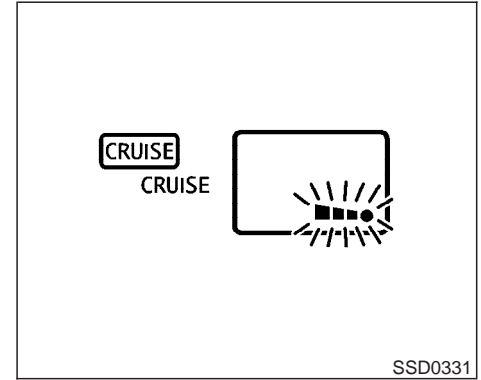

Warning light and display

Condition A

The buzzer sounds and the Intelligent Cruise Control system is canceled automatically in the conditions described below. Part of the system display will come on or blink, making it impossible to set.

- When the VDC is turned off.
- When the VDC operates
- When a tire slips
- When strong light (sunlight, etc.) is directly

Condition B

When the sensor window is dirty, making it impossible to detect a vehicle ahead, the ICC system is automatically canceled.

The buzzer sounds and the system warning light (Orange) will come on and the set distance indicators will blink.

Action to take:

If the warning light comes on, park the vehicle in a safe place, turn the engine off. Clean the dirty parts with a soft cloth and then perform the settings again.

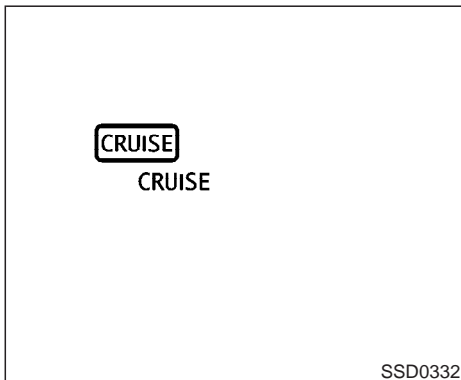

Condition C

When the ICC system is not operating properly, the buzzer sounds and the system warning light (Orange) will come on.

Action to take:

If the warning light comes on, park the vehicle in a safe place. Turn the engine off and then perform the settings again.

If it is not possible to set or the indicator stays on, it may indicate that the system is malfunctioning. Although the vehicle is still driveable under normal conditions, have the vehicle checked at an INFINITI dealer.

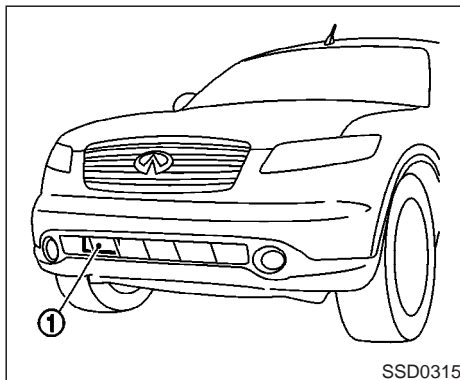

How to handle the sensor

The sensor for the ICC system ① is located below the front bumper.

To keep the ICC system operating properly, be sure to observe the following:

- Always keep the sensor clean. Wipe dirty parts with a soft cloth carefully so as not to damage them.
- Do not impact the areas around the sensor. Do not touch or disassemble the screw located on the sensor. Doing so could cause failure or malfunction. If the sensor installation part is deformed due to an ac-

cident, contact an INFINITI dealer.

- Do not attach a sticker (including transparent material) or install an accessory near the sensor. This could cause failure or malfunction.

CONVENTIONAL (FIXED SPEED) CRUISE CONTROL MODE

This mode allows driving at a speed between 25 to 90 MPH (40 to 144 km/h) without keeping your foot on the accelerator pedal.



WARNING

- **In the conventional (fixed speed) cruise control mode, a warning buzzer does not sound to warn you if you are too close to the vehicle ahead, as neither the presence of the vehicle ahead nor the vehicle-to-vehicle distance is detected.**
- **Pay special attention to the distance between your vehicle and the vehicle ahead of you or a collision could occur.**

- Always confirm the setting in the Intelligent Cruise Control system display.
- Do not use the conventional (fixed speed) cruise control mode when driving under the following conditions:
 - when it is not possible to keep the vehicle at set speed.
 - in heavy traffic or in traffic that varies in speed.
 - on winding or hilly roads.
 - on slippery roads (rain, snow, ice, etc.)
 - in very windy areas.
- Doing so could cause a loss of vehicle control and result in an accident.

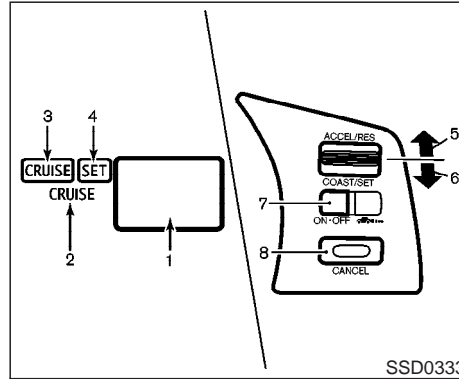

Conventional (fixed speed) cruise control mode display and switch

The display is located under the tachometer.

1. Intelligent Cruise Control system display
2. ICC system warning light (Orange)
The light comes on if there is a malfunction in the ICC system.
3. ON/OFF switch indicator light (Green)
Indicates that the ON/OFF switch is ON.
4. Cruise set switch indicator light
The light comes on while the vehicle speed is controlled by the conventional (fixed

speed) cruise control mode of the ICC system.

5. ACCELERATE/RESUME switch:
Resumes set speed or increases speed incrementally.
6. COAST/SET switch:
Sets the desired cruise speed, reduces speed incrementally.
7. ON/OFF switch:
Master switch to activate the system
8. CANCEL switch:
Deactivates the system without erasing the set speed.

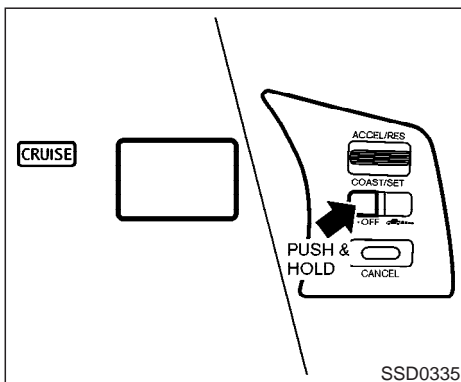

Operating conventional (fixed speed) cruise control mode

To turn on the conventional (fixed speed) cruise control mode, push and hold the ON/OFF switch for longer than about 1.5 seconds.

When pushing the ON/OFF switch on, the Intelligent Cruise Control system display and the CRUISE indicator light (Green) in the instrument cluster come on. After you hold the ON/OFF switch on for longer than about 1.5 seconds, the Intelligent Cruise Control system display goes out. The CRUISE indicator keeps lighting. You can now set your desired cruising

speed. Pushing the ON/OFF switch again will turn the system completely off.

When the ignition switch is turned off, the system is also automatically turned off. To use the Intelligent Cruise Control again, push the ON/OFF switch (vehicle-to-vehicle distance control mode) or push and hold it (conventional cruise control mode) again to turn it on.



CAUTION

To avoid accidentally engaging cruise control, make sure to turn the ON/OFF switch off when not using the Intelligent Cruise Control.

To set cruising speed, accelerate your vehicle to the desired speed, push the COAST/SET switch and release it. (The SET indicator light will come on.) Take your foot off the accelerator pedal. Your vehicle will maintain the set speed.

- **To pass another vehicle**, depress the accelerator pedal. When you release the pedal, the vehicle will return to the previously set speed.
- The vehicle may not maintain the set speed when going up or down steep hills. If this

happens, drive without the Intelligent Cruise Control.

To cancel the preset speed, follow either three of these methods:

- Push the CANCEL button. The SET indicator light will go out.
- Tap the brake pedal. The SET indicator light will go out.
- Turn the ON/OFF switch off. Both the CRUISE indicator and SET indicator lights will go out.

To reset at a faster cruising speed, use one of the following three methods:

- Depress the accelerator pedal. When the vehicle attains the desired speed, push and release the COAST/SET switch.
- Push and hold the ACCEL/RES set switch. When the vehicle attains the speed you desire, release the switch.
- Push, then quickly release the ACCEL/RES switch. Each time you do this, the set speed will increase by about 1 MPH (1.6 km/h).

To reset at a slower cruising speed, use one of the following three methods:

- Lightly tap the brake pedal. When the vehicle attains the desired speed, push the

COAST/SET switch and release it.

- b) Push and hold the COAST/SET switch. Release the switch when the vehicle slows down to the desired speed.
- c) Push, then quickly release the COAST/SET switch. Each time you do this, the set speed will decrease by about 1 MPH (1.6 km/h).

To resume the preset speed, push and release the ACCEL/RES switch. The vehicle will resume the last set cruising speed when the vehicle speed is over 25 MPH (40 km/h).

Automatic cancellation

A buzzer sounds under the following conditions and the control is automatically canceled.

- When the vehicle slows down over 8 MPH (13 km/h) than the set speed.
- When the vehicle speed falls below approximately 20 MPH (32 km/h).
- When the selector lever is shifted to a position other than D (Drive), including the manual shift mode.
- When the parking brake is applied.
- When the VDC operates (except ABS, which is functional with ICC system operation).

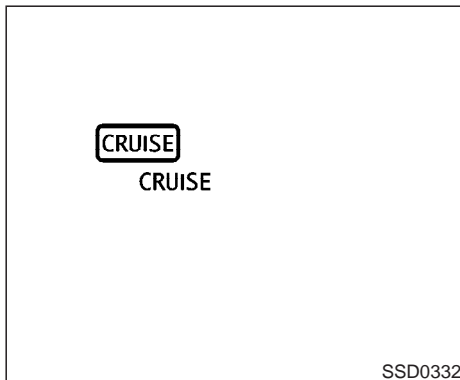

Warning light

When the system is not operating properly, the buzzer sounds and the system warning light (Orange) will come on.

Action to take:

If the warning light comes on, park the vehicle in a safe place. Turn the engine off and then perform the setting again.

If it is not possible to set or the indicator stays on, it may indicate that the system is malfunctioning. Although the vehicle is still driveable under normal conditions, have the vehicle checked at an INFINITI dealer.

BRAKE ASSIST (WITH PREVIEW FUNCTION) (for Intelligent Cruise Control System equipped models) BRAKE ASSIST

When the force applied to the brake pedal exceeds a certain level, the Brake Assist is activated and generates a greater braking force than that of a conventional brake booster even with light pedal force.



WARNING

The Brake Assist is only an aid to assist braking operation and is not a collision warning or avoidance device. It is the driver's responsibility to stay alert, drive safely and be in control of the vehicle at all times.

PREVIEW FUNCTION

When the Preview Function identifies the need to apply emergency braking by sensing the vehicle ahead in the same lane and the distance and relative speed from it, it applies the brake pre-pressure before the driver depresses the brake pedal and helps improve brake response by reducing pedal free play clearances.

- This system will not operate when the ve-

hicle is moving at approximately 20 MPH (32 km/h) or less.

- The pre-pressure function ceases when the following conditions are met:
 - a) When the driver depresses the accelerator pedal or the brake pedal.
 - b) If the driver does not operate the accelerator or brake pedal within approximately 1 second.

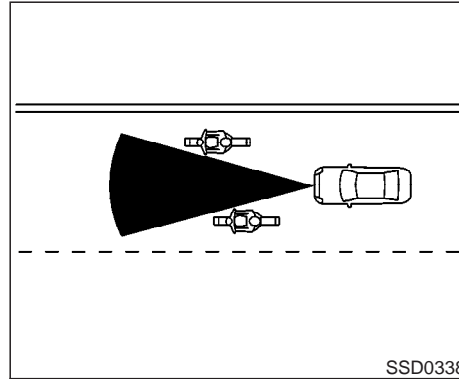

- The sensor will not detect:
 - a) Pedestrians or objects in the roadway
 - b) Oncoming vehicles in the same lane
 - c) Motorcycles or scooters traveling offset in the travel lane as illustrated



WARNING

- The Preview Function is only an aid to assist the driver and is not a collision warning or avoidance device.

Although the brake operation is controlled by the system, it does not automatically decelerate the vehicle speed.

It is the driver's responsibility to stay alert, drive safely and be in control of the vehicle at all times.

- As there is a performance limit to the Preview Function, never rely solely on this system. This system does not correct careless inattentive or absent-minded driving, or overcome poor visibility in rain, fog, or other bad weather. Reduce vehicle speed by depressing the brake pedal, in order to maintain a safe distance between vehicles.
- The system may not detect the vehicle in front of you in certain road or weather conditions. The Preview Function may not operate properly under the following conditions. The vehicle is still drivable under normal conditions and the Brake Assist will operate.

- When rain, snow or dirt adhere to the system sensor.
- When strong light (for example, at sunrise or sunset) is directly shining on the front of the vehicle.
- Winding or hilly roads may cause the sensor to temporarily not detect a vehicle in the same lane or may detect objects or vehicles in other lanes.
- Vehicle position in the lane may cause the sensor to temporarily not detect a vehicle in the same lane or may detect objects or vehicles in other lanes.

- When the Preview Function operates, the brake pedal may move slightly and may make a small noise. This is not a system malfunction.

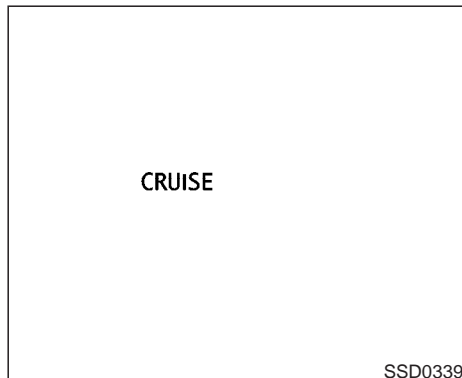

Warning light and display

When the Preview Function is not operating properly, the buzzer sounds and the system warning light (Orange) will come on.

Action to take:

If the warning light comes on, park the vehicle in a safe place. Turn the engine off and then perform the settings again.

If the indicator stays on, it may indicate that the Preview Function is malfunctioning (the brake is operative). Although the Vehicle is still driveable under normal condi-

tions, have the vehicle checked at an INFINITI dealer.

How to handle the sensor

The sensor for the Preview Function, that is common with Intelligent Cruise Control, is located below the front bumper.

To keep the Preview Function operating properly, be sure to observe the following:

- Always keep the sensor clean. Wipe dirty parts with a soft cloth carefully so as not to damage them.
- Do not impact the areas around the sensor. Do not touch or disassemble the screw located on the sensor. Doing so could cause failure or malfunction. If the sensor installation part is deformed due to an accident, contact an INFINITI dealer.
- Do not attach a sticker (including transparent material) or install an accessory near the sensor. This could cause failure or malfunction.

BREAK-IN SCHEDULE



During the first 1,200 miles (2,000 km), follow these recommendations to obtain maximum engine performance and ensure the future reliability and economy of your new vehicle. Failure to follow these recommendations may result in shortened engine life and reduced engine performance.

- Avoid driving for long periods at constant speed, either fast or slow. Do not run the engine over 4,000 rpm.
- Do not accelerate at full throttle in any gear.
- Avoid quick starts.
- Avoid hard braking as much as possible.
- Do not tow a trailer for the first 500 miles (800 km).

INCREASING FUEL ECONOMY

- Accelerate slowly and smoothly. Maintain cruising speeds with a constant accelerator position.
 - Drive at moderate speeds on the highway. Driving at high speed will lower fuel economy.
 - Avoid unnecessary stopping and braking. Maintain a safe distance behind other vehicles.
 - Use a proper gear range which suits road conditions. On level roads, shift into high gear as soon as possible.
 - Avoid unnecessary engine idling.
 - Keep your engine tuned up.
 - Follow the recommended periodic maintenance schedule.
 - Keep the tires inflated at the correct pressure. Low pressure will increase tire wear and waste fuel.
 - Keep the front wheels in correct alignment. Improper alignment will cause not only tire wear but also lower fuel economy.
 - Air conditioner operation lowers fuel economy. Use the air conditioner only when necessary.
- When cruising at highway speeds, it is more economical to use the air conditioner and leave the windows closed to reduce drag.

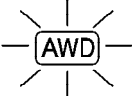
AWD WARNING LIGHT

Warning light	Comes on or blinks when
 Comes on	There is a malfunction in the all wheel drive system.
 Blinks rapidly	The power-train oil temperature rises abnormally.
 Blinks slowly	The difference in wheel rotation is large.

SSD0336

The AWD warning light is located in the meter.

The AWD warning light comes on when the key switch is turned to ON. It turns off soon after the engine is started.

If any malfunction occurs in the AWD system,

the warning light comes on while engine is running.

The warning light may blink rapidly (about twice per second) while trying to free a stuck vehicle due to high power train oil temperature. The driving mode may change to 2 wheel drive. If the warning light blinks rapidly, stop the vehicle with the engine idling in a safe place immediately. Then if the light goes off after a while, you can continue driving.

A large difference between the diameters of front and rear wheels will make the warning light blink slowly (about once per two seconds). Pull off the road in a safe area, and idle the engine. Check that all tire sizes are the same, tire pressure is correct and tires are not worn.

If the warning light is blinking after the above operation, have your vehicle checked by an INFINITI dealer as soon as possible.



CAUTION

- Do not place an AWD equipped vehicle on a two wheel dynamometer or raise two wheels off the ground and shift the transmission to any D (drive) or R (reverse) position. Doing so may result in transmission damage or unexpected vehicle movement which could result in serious vehicle damage or personal injury.
- Do not attempt to test an AWD equipped vehicle with two wheels on a two wheel dynamometer and the other two wheels raised. Doing so may result in transmission damage or unexpected vehicle movement which could result in serious vehicle damage or personal injury.
- If the warning light comes on while driving, there may be a malfunction in the AWD system. Reduce the vehicle speed and have your vehicle checked by an INFINITI dealer as soon as possible.

PARKING/PARKING ON HILLS

- If the warning light is still on after the above operation, have your vehicle checked by an INFINITI dealer as soon as possible.
- The power train may be damaged if you continue driving with the warning light blinking rapidly.

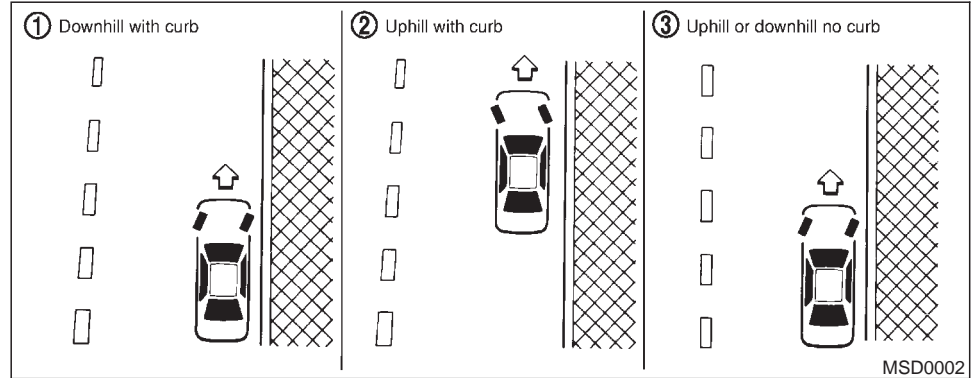

WARNING

- Do not stop or park the vehicle over flammable materials such as dry grass, waste paper or rags. They may ignite and cause a fire.
- Never leave the engine running while the vehicle is unattended.
- Never leave children unattended in the vehicle.

1. Firmly apply the parking brake.
2. Move the selector lever to the P (Park) position.



WARNING

- Safe parking procedures require that both the parking brake be set and the transmission placed into P (Park) for automatic transmission models. Failure to do so could cause the vehicle to move unexpectedly or roll away.

and result in an accident.

- **Make sure the automatic transmission selector lever has been pushed as far forward as it can go and cannot be moved without depressing the button at the end of the lever.**

3. To help prevent the vehicle from rolling into the street when parked on a sloping drive way, it is a good practice to turn the wheels as illustrated.

- **HEADED DOWNHILL WITH CURB: ①**

Turn the wheels into the curb and move the vehicle forward until the curb side wheel gently touches the curb.

- **HEADED UPHILL WITH CURB: ②**

Turn the wheels away from the curb and move the vehicle back until the curb side wheel gently touches the curb.

- **HEADED UPHILL OR DOWNHILL, NO CURB: ③**

Turn the wheels toward the side of the road so the vehicle will move away from the center of the road if it moves.

4. Turn the ignition switch to the LOCK position and remove the key (if a metal key is used).

POWER STEERING

The power assisted steering is designed to use a hydraulic pump, driven by the engine, to assist steering.

If the engine stops or the drive belt breaks, you will still have control of the vehicle. However, much greater steering effort is needed, especially in sharp turns or at low speeds.



WARNING

If the engine is not running or is turned off while driving, the power assist for the steering will not work. Steering will be much harder to operate.

BRAKE SYSTEM

BRAKING PRECAUTIONS

The brake system has two separate hydraulic circuits. If one circuit malfunctions, you will still have braking at two wheels.

Vacuum assisted brake

The brake booster aids braking by using engine vacuum. If the engine stops, you can stop the vehicle by depressing the brake pedal. However, greater foot pressure on the brake pedal will be required to stop the vehicle and the stopping distance will be longer.

Wet brakes

When the vehicle is washed or driven through water, the brakes may get wet. As a result, your braking distance will be longer and the vehicle may pull to one side during braking.

To dry brakes, drive the vehicle at a safe speed while lightly pressing the brake pedal to heat-up the brakes. Do this until the brakes return to normal. Avoid driving the vehicle at high speeds until the brakes function correctly.

Using the brakes

Avoid resting your foot on the brake pedal while driving. This overheats the brakes, increases wear on the brake linings and pads, and reduces gas mileage.

5-44 Starting and driving

To help save the brakes and to prevent the brakes from overheating, reduce speed and downshift to a lower gear before going down a slope or long grade. Overheated brakes may reduce braking performance and could result in loss of vehicle control.



WARNING

- **While driving on a slippery surface, be careful when braking, accelerating or downshifting. Abrupt braking or accelerating could cause the wheels to skid and result in an accident.**
- **If the engine is not running or is turned off while driving, the power assist for the brakes will not work. Braking will be harder.**

PREVIEW FUNCTION (for Intelligent Cruise Control system equipped models)

When the Preview Function equipped with Intelligent Cruise Control system identifies the need to apply emergency braking by sensing the vehicle ahead in the same lane and the distance and relative speed from it, it applies

the brake pre-pressure before the driver depresses the brake pedal and helps improve brake response by reducing pedal free play clearances.

For more details, please refer to “Brake assist (with preview function)” in this section.

ANTI-LOCK BRAKE SYSTEM (ABS)

The anti-lock brake system controls the brakes so the wheels will not lock when braking abruptly or when braking on slippery surfaces. The system detects the rotation speed at each wheel and varies the brake fluid pressure to prevent each wheel from locking and sliding. By preventing wheel lockup, the system helps the driver maintain steering control and helps to minimize swerving and spinning on slippery surfaces.

Using the system

Depress the brake pedal and hold it down.



WARNING

Do not pump the brake pedal. Doing so may result in increased stopping distances.

Normal operation

The anti-lock brake system will not operate at speeds below 3 to 6 MPH (5 to 10 km/h) to completely stop the vehicle. (The speeds will vary according to road conditions.) When the anti-lock system senses that one or more wheels are close to locking up, the actuator (under the hood) rapidly applies and releases hydraulic pressure (like pumping the brakes very quickly). While the actuator is working, you may feel a pulsation in the brake pedal and hear a noise or vibration from the actuator under the hood. This is normal and indicates that the anti-lock system is working properly. However, the pulsation may indicate that road conditions are hazardous and extra care is required while driving.

Self-test feature

The anti-lock brake system consists of electronic sensors, electric pumps, and hydraulic solenoids controlled by a computer. The computer has a built-in diagnostic feature that tests the system each time you start the engine and move the vehicle at a low speed in forward or reverse. When the self-test occurs, you may hear a clunk noise and/or feel a pulsation in the brake pedal. This is normal and is not an indication of any malfunction. If the computer senses any malfunction, it switches the anti-

lock brake system OFF and turns on the ABS warning light in the dashboard. The brake system will then behave normally, but without anti-lock assistance.

If the light comes on during the self check, or while you are driving, you should take your vehicle to your INFINITI dealer for repair at your earliest convenience.



WARNING

The anti-lock brake system is a sophisticated device, but it cannot prevent accidents resulting from careless or dangerous driving techniques. It can help maintain vehicle control during braking on slippery surfaces, but remember that the stopping distance on slippery surfaces will be longer than on normal surfaces, even with the anti-lock system. Stopping distances may also be longer on rough, gravel or snow covered roads, or if you are using tire chains. Always maintain a safe distance from the vehicle in front of you. Ultimately, the responsibility for safety of yourself and others rests in the hands of the

driver.

Tire type and condition of tires may also affect braking effectiveness.

- **When replacing tires, install the specified size of tires on all four wheels.**
- **When installing a spare tire, make sure it is the proper size and type as specified on the tire placard. See “Vehicle identification” in the “9. Technical and consumer information” section for tire placard location.**

VEHICLE DYNAMIC CONTROL (VDC) SYSTEM

When accelerating or driving on slippery surfaces, the tires may spin or slide. With the vehicle dynamic control (VDC) system, sensors detect these movements and control the braking and engine output to help improve vehicle stability.

- When the vehicle dynamic control (VDC) system is operating, the slip indicator in the instrument panel blinks.
- When only the traction control (TCS) system portion of the vehicle dynamic control system is operating, the slip indicator will also blink.
- If the slip indicator blinks, the road conditions are slippery. Be sure to adjust your speed and driving to these conditions. Be sure to drive carefully. See “Slip indicator light”, and “Vehicle dynamic control off indicator light” in the “2. Instruments and controls” section.
- Indicator light
If a malfunction occurs in the system, the SLIP and $\frac{\text{VDC}}{\text{OFF}}$ indicator lights come on in the meter panel.
As long as these indicator lights are on, the traction control function is canceled.

The VDC system uses a Brake Limited Slip Differential (LSD) system to improve vehicle

traction. The brake LSD system works when one of the driving wheels is spinning on a slippery surface. The brake LSD system brakes the spinning wheel which distributes the driving power to the other drive wheel. If the vehicle is operated with the vehicle dynamic control system turned off, all VDC and TCS functions will be turned off. The brake LSD system and ABS will still operate with the VDC system off. If the brake LSD system or the ABS is activated, the slip indicator light will blink and you may hear a clunk noise and/or feel a pulsation in the brake pedal. This is also normal and indicates the brake fluid pressure is controlled properly.

While the VDC system is operating, you may feel a pulsation in the brake pedal and hear a noise or vibration from under the hood. This is normal and indicates that the VDC system is working properly.

The computer has a built in diagnostic feature that tests the system each time you start the engine and move the vehicle forward or in reverse at a slow speed. When the self-test occurs, you may hear a clunk noise and/or feel a pulsation in the brake pedal. This is normal and is not an indication of a malfunction.



WARNING

- The vehicle dynamic control system is designed to help improve driving stability but does not prevent accidents due to abrupt steering operation at high speeds or by careless or dangerous driving techniques. Reduce vehicle speed and be especially careful when driving and cornering on slippery surfaces and always drive carefully.
- If engine related parts such as muffler are not standard equipment or are extremely deteriorated, the vehicle dynamic control off indicator light and slip indicator light may come on.
- Do not modify the vehicle's suspension. If suspension parts such as shock absorbers, struts, springs, stabilizer bars and bushings are not INFINITI-approved for your vehicle or are extremely deteriorated, the vehicle dynamic control system may not operate properly. This could adversely affect vehicle handling performance, and the vehicle dynamic control off indicator light may come on.

- If brake related parts such as brake pads, rotors and calipers are not standard equipment or are extremely deteriorated, the vehicle dynamic control off indicator light may illuminate.
- When driving on extremely inclined surfaces such as higher banked corners, the vehicle dynamic control system may not operate properly and the vehicle dynamic control off indicator light may come on. Do not drive on these types of roads.
- If wheels or tires other than the recommended ones are used, the vehicle dynamic control system may not operate properly and the vehicle dynamic control off indicator light may come on.
- The vehicle dynamic control system is not a substitute for winter tires or tire chains on a snow covered road.
- When driving on unstable surfaces such as a turntable, ferry, elevator or ramp, the vehicle dynamic control off indicator light may illuminate. This is not a malfunction. Restart the engine after driving onto a stable surface.

COLD WEATHER DRIVING

FREEING A FROZEN DOOR LOCK

To prevent a door lock from freezing, apply de-icer or glycerin to it through the key hole. If the lock becomes frozen, heat the key before inserting it into the key hole.

ANTI-FREEZE

In the winter when it is anticipated that the temperature will drop below 32°F (0°C), check anti-freeze to assure proper winter protection. For additional information, see “Engine cooling system” in the “8. Maintenance and do-it-yourself” section.

BATTERY

If the battery is not fully charged during extremely cold weather conditions, the battery fluid may freeze and damage the battery. To maintain maximum efficiency, the battery should be checked regularly. For additional information, see “Battery” in the “8. Maintenance and do-it-yourself” section.

DRAINING OF COOLANT WATER

If the vehicle is to be left outside without anti-freeze, drain the cooling system by opening the drain plug located under the radiator. Refill before operating the vehicle. See “Engine cooling system” in the “8. Maintenance

and do-it-yourself” section for changing engine coolant.

TIRE EQUIPMENT

1. SUMMER tires are of a tread design to provide superior performance on dry pavement. However, the performance of these tires will be substantially reduced in snowy and icy conditions. If you operate your vehicle on snowy or icy roads, INFINITI recommends the use of MUD & SNOW or ALL SEASON tires on all four wheels. Please consult your INFINITI dealer for the tire type, size, speed rating and availability information.
2. For additional traction on icy roads, studded tires may be used. However, some provinces and states prohibit their use. Check local, state and provincial laws before installing studded tires.

Skid and traction capabilities of studded snow tires, on wet or dry surfaces, may be poorer than that of non-studded snow tires.

3. Tire chains may be used if desired. Make sure they are of proper size for the tires on your vehicle and are installed according to the chain manufacturer’s suggestions. Use of tire chains may be prohibited according to location. Check the local laws before

installing tire chains. When installing tire chains, make sure they are of proper size for the tires on your vehicle and are installed according to the chain manufacturer's suggestions. **Use only SAE Class S chains.** Class "S" chains are used on vehicles with restricted tire to vehicle clearance. Vehicles that can use Class "S" chains are designed to meet the SAE standard minimum clearances between the tire and the closest vehicle suspension or body component required to accommodate the use of a winter traction device (tire chains or cables). The minimum clearances are determined using the factory equipped tire size. Other types may damage your vehicle. Use chain tensioners when recommended by the tire chain manufacturer to ensure a tight fit. Loose end links of the tire chain must be secured or removed to prevent the possibility of whipping action damage to the fenders or underbody. If possible, avoid fully loading your vehicle when using tire chains. In addition, drive at a reduced speed. Otherwise, your vehicle may be damaged and/or vehicle handling and performance may be adversely affected.

- **Never install tire chains on TEMPORARY USE ONLY spare tires.**

5-48 Starting and driving

- **Do not use tire chains on dry roads.**
- **Tire chains must be installed only on the rear wheels and not on the front wheels.**

Do not drive with tire chains on paved roads which are clear of snow. Driving with chains in such conditions can cause damage to the various mechanisms of the vehicle due to some overstress.

4. For all wheel drive:
If you install snow tires, they must also be the same size, brand, construction and tread pattern on all four wheels.

SPECIAL WINTER EQUIPMENT

It is recommended that the following items be carried in the vehicle during winter:

- a scraper and stiff-bristled brush to remove ice and snow from the windows and wiper blades.
- a sturdy, flat board to be placed under the jack to give it firm support.
- a shovel to dig the vehicle out of snow-drifts.
- extra window washer fluid to refill the reservoir tank.

DRIVING ON SNOW OR ICE



WARNING

- Wet ice (32°F, 0°C and freezing rain), very cold snow or ice can be slick and very hard to drive on. The vehicle will have a lot less traction or grip under these conditions. Try to avoid driving on wet ice until the road is salted or sanded.
- Whatever the condition, drive with caution. Accelerate and slow down with care. If accelerating or downshifting too fast, the drive wheels will lose even more traction.
- Allow more stopping distance under these conditions. Braking should be started sooner than on dry pavement.
- Allow greater following distances on slippery roads.
- Watch for slippery spots (glare ice). These may appear on an otherwise clear road in shaded areas. If a patch of ice is seen ahead, brake before

reaching it. Try not to brake while actually on the ice, and avoid any sudden steering maneuvers.

- Do not use cruise control on slippery roads.
- Snow can trap dangerous exhaust gases under your vehicle. Keep snow clear of the exhaust pipe and from around your vehicle.

ENGINE BLOCK HEATER (if so equipped)

An engine block heater to assist extreme cold temperature starting is available through your INFINITI dealer.



WARNING

Do not use your heater with an ungrounded electrical system or two-pronged (cheater) adapters. You can be injured by an electrical shock if you use an ungrounded connection.

MEMO

6 In case of emergency

Roadside assistance program.....	6-2
Flat tire	6-2
Low tire pressure warning system (if so equipped)	6-2
Changing a flat tire	6-3
Jump starting.....	6-8
Push starting	6-11
If your vehicle overheats	6-11
Towing your vehicle	6-12
Towing recommended by INFINITI	6-13
Vehicle recovery (freeing a stuck vehicle)	6-14

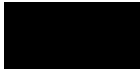

ROADSIDE ASSISTANCE PROGRAM

Every new INFINITI comes with a 4 year, unlimited mileage Roadside Assistance plan. In the event of a roadside emergency, Roadside Assistance Service is available to you. Please refer to your INFINITI Warranty Information Booklet for details. Both the Warranty Booklet and Roadside Assistance Calling Card in your Owner's Literature Portfolio provide the Toll-Free Number to call for assistance. Roadside Assistance is provided 24 hours a day, 365 days a year, for 4 years from the date sold to give emergency roadside help, in the event of mechanical or nonmechanical trouble(s) such as flat tires, out-of-gas, dead battery, lost keys, mechanical breakdown, accident, etc.

FLAT TIRE

LOW TIRE PRESSURE WARNING SYSTEM (if so equipped)

This vehicle is equipped with the low tire pressure warning system. It monitors tire pressure of all tires except the spare. When the low tire pressure warning light is lit, one or more of your tires is significantly under-inflated. If equipped, the system also displays pressure of all tires (except the spare tire) on the display screen by sending a signal from a sensor that is installed in each wheel. If the vehicle is being driven with low tire pressure (lower than 26 psi, 180 kPa), the low tire pressure warning system will activate and warn you of it by the low tire pressure warning light or if you select the tire pressure information in the display, a WARNING (FLAT TIRE) displayed on the screen. This system will activate only when the vehicle is driven at speeds above 20 MPH (32 km/h). For more details, please refer to "Warning/indicator lights and audible reminders" in the "2. Instruments and controls" section, "Tire pressure information" in the "4. Display screen, heater, air conditioner and audio systems" section and "Low tire pressure warning system" in the "5. Starting and driving" section.



WARNING

- If the low tire pressure warning light blinks or a **WARNING** is displayed on the display screen while driving, avoid sudden steering maneuvers or abrupt braking, reduce vehicle speed, pull off the road to a safe location and stop the vehicle as soon as possible. Serious vehicle damage could occur and may lead to an accident and could result in serious personal injury. Check the pressure for all four tires. Adjust the pressure to the **COLD** tire pressure shown on the Tire and Loading Information label to turn the low tire pressure warning light **OFF**. If you have a flat tire, replace it with a spare tire as soon as possible.
- When a spare tire is mounted or a wheel is replaced, the tire pressure and the low tire pressure warning system will not be functioning nor will their lights illuminate. Contact your INFINITI dealer as soon as pos-

sible for tire replacement and/or system resetting.

- Do not inject any tire liquid or aerosol tire sealant into the tires, as this may cause a malfunction of the tire pressure sensors.

CHANGING A FLAT TIRE

If you have a flat tire, follow the instructions below.

Stopping the vehicle

1. Safely move the vehicle off the road away from traffic.
2. Turn on the hazard warning flashers.
3. Park on a level surface and apply the parking brake. Shift the selector lever in P (Park) position.
4. Turn off the engine.
5. Raise the hood to warn other traffic, and to signal professional road assistance personnel that you need assistance.
6. Have all passengers get out of the vehicle and stand in a safe place, away from traffic and clear of the vehicle.



WARNING

- Make sure that the parking brake is securely applied and the automatic transmission into P (Park).
- Never change tires when the vehicle is on a slope, ice or slippery areas. This is hazardous.
- Never change tires if oncoming traffic is close to your vehicle. Wait for professional road assistance.
- When a spare tire is mounted or a wheel is replaced, the tire pressure of that tire will not be indicated and not be monitored by the low tire pressure warning system. Contact your INFINITI dealer as soon as possible for tire replacement and/or system resetting. (For models with the low tire pressure warning system)

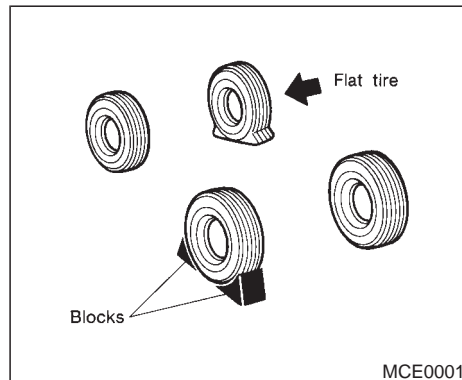

Blocking wheels

Place suitable blocks at both the front and back of the wheel diagonally opposite the flat tire to prevent the vehicle from rolling when it is jacked up.



WARNING

Be sure to block the wheel as the vehicle may move and could cause personal injury.

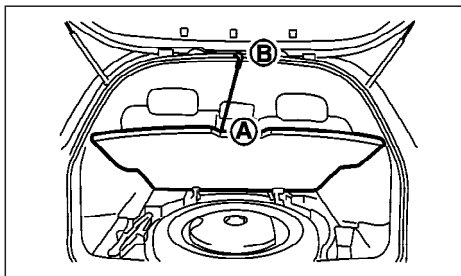

Type A

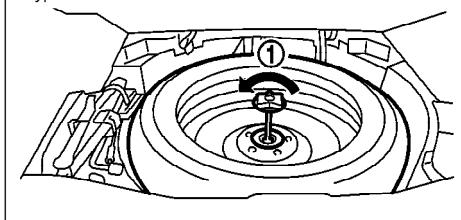

Type B

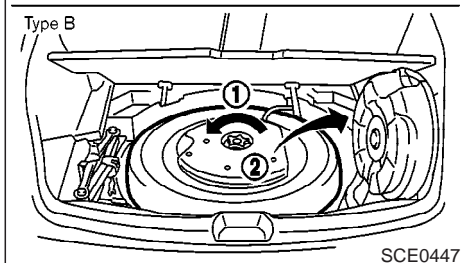

SCE0447

Getting the spare tire and tools

Pull up the floor cover (A) and hang the strap to upper body (B) as illustrated.

Type A:

Turn the retainer counterclockwise (1) and remove the spare tire.

Type B:

Turn the retainer counterclockwise (1), remove the subwoofer (2) and place it on the side of the luggage room (with the flat surface facing down), then remove the spare tire. Be careful not to let the subwoofer fall down.

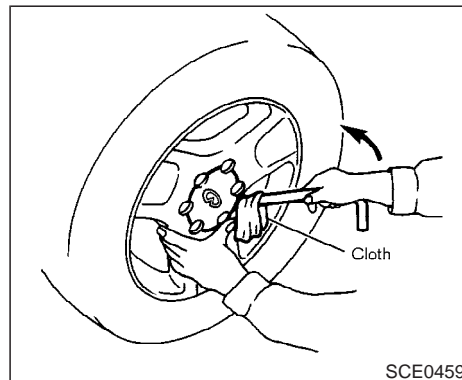

SCE0459

Removing wheel cap



CAUTION

Do not use your hands to pry off wheel caps. Doing so could result in personal injury.

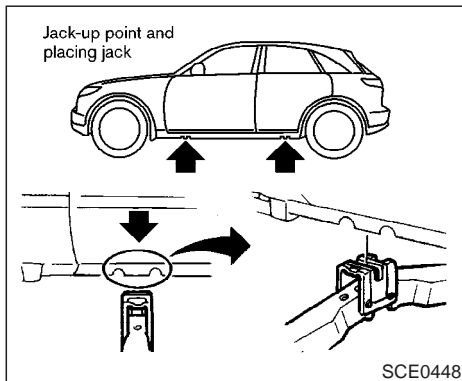

Jacking up the vehicle and removing the damaged tire

Carefully read the caution label attached to the jack body and the following instructions.

1. Remove the jack holder loosening the jack shaft.
2. Place the jack directly under the jack-up point as illustrated above so that top of the jack contacts the vehicle at the jack up point. Align the jack head between the two notches in the front or the rear as shown. Also fit the groove of the jack head between the notches as shown.

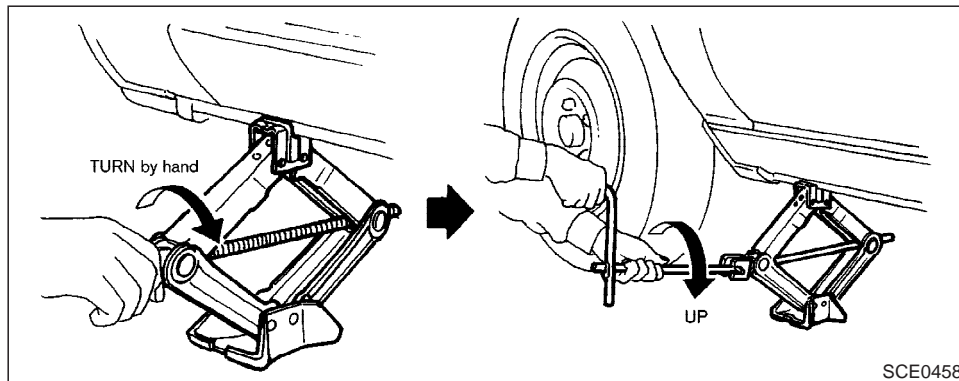

The jack should be used on level firm ground.

3. Loosen each wheel nut one or two turns by turning counterclockwise with the wheel nut wrench. **Do not remove the wheel nuts until the tire is off the ground.**
4. Carefully raise the vehicle until the tire clears the ground. To lift the vehicle, securely hold the jack lever and rod with both hands as shown above. Remove the wheel nuts, and then remove the tire.



WARNING

- Don't use the jack with the holder attached in case it breaks, or it could lead to a personal injury.
- Never get under the vehicle while it is supported only by the jack. If it is necessary to work under the vehicle, support it with safety stands.
- Use only the jack provided with your vehicle to lift the vehicle. Do not use

the jack provided with other vehicles to your vehicle.

The jack is designed only for lifting your vehicle during a tire change.

- Use the correct jack up points; never use any other part of the vehicle for jack support.
- Never jack up the vehicle more than necessary.
- Never use blocks on or under the jack.
- Do not start or run engine while vehicle is on the jack, as it may cause the vehicle to move. This is especially true for vehicles with limited slip differential carriers.
- Do not allow passengers to stay in the vehicle while it is on the jack.

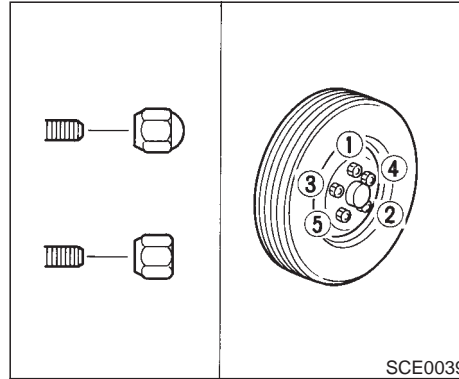

Installing the spare tire

The T-type spare tire is designed for emergency use. See specific instructions under the heading “Wheels and tires” in the “8. Maintenance and do-it-yourself” section.

1. Clean any mud or dirt from the surface between the wheel and hub.
2. Carefully put the spare tire on and tighten the wheel nuts finger tight.
3. With the wheel nut wrench, tighten wheel nuts alternately and evenly as illustrated until they are tight.

4. Lower the vehicle slowly until the tire touches the ground. Then, with the wheel nut wrench, tighten the wheel nuts securely in the sequence as illustrated. (①, ②, ③, ④, ⑤). Lower the vehicle completely.



WARNING

- Incorrect wheel nuts or improperly tightened wheel nuts can cause the wheel to become loose or come off. This could cause an accident.
- Do not use oil or grease on the wheel studs or nuts. This could cause the nuts to become loose.

Retighten the wheel nuts after the vehicle has been driven for 600 miles (1,000 km) (also in cases of a flat tire, etc.).

As soon as possible tighten the wheel nuts to the specified torque with a torque wrench.

Wheel nut tightening torque:

80 ft-lb (108 N-m)

The wheel nuts must be kept tightened to specifications at each lubrication interval.

Adjust tire pressure to the COLD pressure.

COLD pressure:

After vehicle has been parked for three hours or more or driven less than 1 mile (1.6 km).

COLD tire pressures are shown on the tire placard affixed to the inside of the driver side center pillar.

For models equipped with the low tire pressure warning system:

After adjusting tire pressure to the COLD tire pressure, the display of the tire pressure information may show higher pressure than the COLD tire pressure after the vehicle has been driven more than 1 mile (1.6 km). This is because the tire pressurizes as the tire temperature rises. This does not indicate a system malfunction.

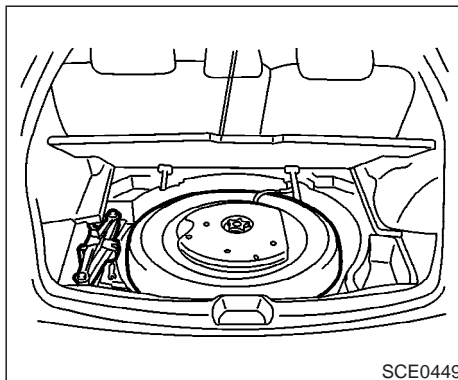

Stowing the damaged tire and tools

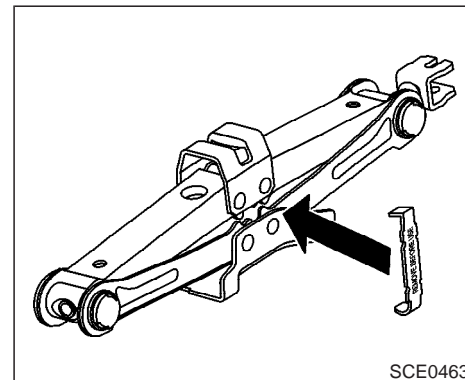

Install the jack holder in the correct direction. Refer to the illustration. Turn the jack handle to secure the jack holder to the jack.

Securely store the spare tire and jacking equipment in the vehicle.



WARNING

- Always make sure that the spare tire and jacking equipment are properly secured after use. Such items can become dangerous projectiles in an accident or sudden stop.

The T-type (temporary) spare tire and small size spare tire are designed for emergency use. See “Wheels and tires” in the “8. Maintenance and do-it-yourself” section.

If needed Roadside Assistance is available. Please see your INFINITI Warranty Information Booklet or Roadside Assistance I.D. Card for the toll-free number to call (U.S.) or Warranty Information Booklet (Canada).

JUMP STARTING

To start your engine with a booster battery, the instructions and precautions below must be followed.



WARNING

- If done incorrectly, jump starting can lead to a battery explosion, resulting in severe injury or death. It could also damage your vehicle.
- Explosive hydrogen gas is always present in the vicinity of the battery. Keep all sparks and flames away from the battery.
- Do not allow battery fluid to come into contact with eyes, skin, cloth or painted surfaces. Battery fluid is a corrosive sulphuric acid solution which can cause severe burns. If the fluid should come into contact with anything, immediately flush the contacted area with water.
- Keep battery out of the reach of children.
- The booster battery must be rated at

12 volts. Use of an improperly rated battery can damage your vehicle.

- Whenever working on or near a battery, always wear suitable eye protectors (for example, goggles or industrial safety spectacles) and remove rings, metal bands, or any other jewelry. Do not lean over the battery when jump starting.
- Do not attempt to jump start a frozen battery. It could explode and cause serious injury.
- Your vehicle has an automatic engine cooling fan. It could come on at any time. Keep hands and other objects away from it.
- If the battery of vehicle equipped with the Intelligent Key system is discharged, the ignition knob cannot be moved from the LOCK position, even using the mechanical key or the valet key. Connect the jumper cables to another vehicle, as in the case of a discharged battery, and then the

ignition knob can be moved from the LOCK position. Then, jump start the vehicle.

If needed Roadside Assistance is available. Please see your INFINITI Warranty Information Booklet or Roadside Assistance I.D. Card for the toll-free number to call (U.S.) or INFINITI Warranty Information Booklet (Canada).

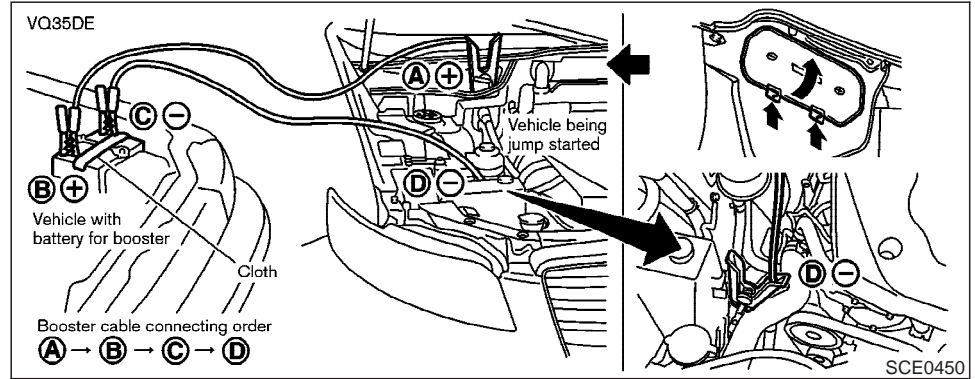

WARNING

Always follow the instructions below. Failure to do so could result in damage to the charging system and cause personal injury.

1. If the booster battery is in another vehicle, position the two vehicles to bring their batteries into close proximity to each other.

Do not allow the two vehicles to touch.

2. Apply parking brake. Move the selector lever to the P (Park) position. Switch off all unnecessary electrical systems (light, heater, air conditioner, etc.).
3. Remove vent caps on the battery (if so equipped). Cover the battery with an old cloth to reduce explosion hazard.
4. Connect jumper cables in the sequence as illustrated (A → B → C → D).



CAUTION

- Always connect positive (+) to positive (+) and negative (-) to body ground (for example, strut mounting bolt, etc. — not to the battery).
- Make sure that cables do not touch moving parts in the engine compartment and that clamps do not contact any other metal.

5. Start the engine of the other vehicle and let it run for a few minutes.
6. Keep the engine speed of the other vehicle at about 2,000 rpm, and start your engine in the normal manner.



CAUTION

Do not keep starter motor engaged for more than 10 seconds. If the engine does not start right away, turn the key off and wait 3 to 4 seconds before trying again.

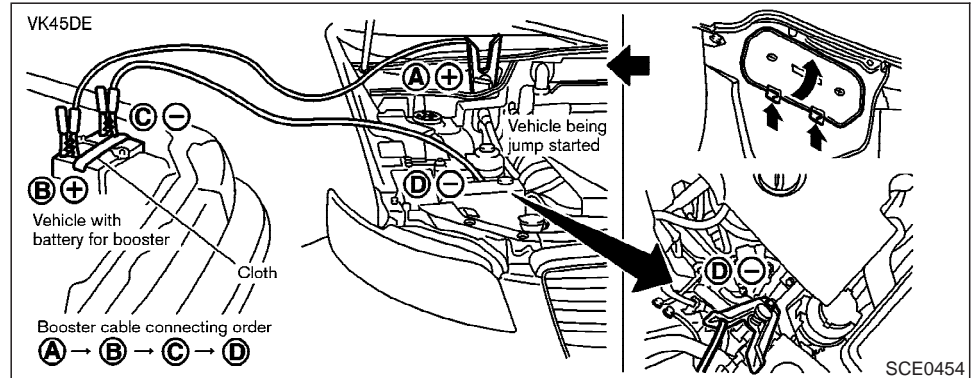

7. After starting your engine, carefully disconnect the negative cable and then the positive cable.
8. Replace the vent caps (if so equipped). Be sure to dispose of the cloth used to cover the vent holes as it may be contaminated with corrosive acid.

PUSH STARTING

Do not attempt to start the engine by pushing.



CAUTION

- **Automatic transmission models cannot be push started. Attempting to do so may cause transmission damage.**

If needed Roadside Assistance is available. Please see your INFINITI Warranty Information Booklet or Roadside Assistance I.D. Card for the toll-free number to call (U.S.) or INFINITI Warranty Information Booklet (Canada).

IF YOUR VEHICLE OVERHEATS



WARNING

- **Do not continue to drive if your vehicle overheats. Doing so could cause a vehicle fire.**
- **To avoid the danger of being scalded, never remove the radiator cap while the engine is still hot. When the radiator cap is removed, pressurized hot water will spurt out, possibly causing serious injury.**
- **Do not open the hood if steam is coming out.**

If your vehicle is overheating (indicated by an extremely high temperature gauge reading), or if you feel a lack of engine power, detect abnormal noise, etc., take the following steps:

1. Move the vehicle safely off the road, apply the parking brake and move the selector lever to the P (Park) position.

Do not stop the engine.

2. Turn off the air conditioner switch. Open all the windows, move the heater or air conditioner temperature control to maximum hot

and fan control to high speed.

3. If engine overheating is caused by climbing a long hill on a hot day, run the engine at a fast idle (approximately 1,500 rpm) until the temperature gauge indication returns to normal.
4. Get out of the vehicle. Look and listen for steam or coolant escaping from the radiator before opening the hood. (If steam or coolant is escaping, turn off the engine.) Do not open the hood further until no steam or coolant can be seen.
5. Open the engine hood.



WARNING

If steam or water is coming from the engine, stand clear to prevent getting burned.

6. Visually check if the cooling fan is running. The radiator hoses and radiator should not leak water.

If coolant is leaking or the cooling fan does not run, stop the engine.



WARNING

- **Be careful not to allow your hands, hair, jewelry or clothing to come into contact with, or to get caught in the cooling fan, or drive belt.**
- **The engine cooling fan can start at any time when the coolant temperature is high.**

7. After the engine cools down, check the coolant level in the reservoir tank with the engine running. Add coolant to the reservoir tank if necessary. Have your vehicle repaired at the nearest INFINITI dealer.

If needed, Roadside Assistance is available. Please see your INFINITI Warranty Information Booklet or Roadside Assistance I.D. Card for the toll-free number to call (U.S.) or INFINITI Warranty Information Booklet (Canada).

TOWING YOUR VEHICLE

When towing your vehicle, all State (Provincial in Canada) and local regulations for towing must be followed. Incorrect towing equipment could damage your vehicle. Towing instructions are available from an INFINITI dealer. Local service operators are generally familiar with the applicable laws and procedures for towing. To assure proper towing and to prevent accidental damage to your vehicle, INFINITI recommends having a service operator tow your vehicle. It is advisable to have the service operator carefully read the following precautions.



WARNING

- **Never ride in a vehicle that is being towed.**
- **Never get under your vehicle after it has been lifted by a tow truck.**



CAUTION

- **When towing, make sure that the transmission, axles, steering system**

and power train are in working condition. If any unit is damaged, dollies must be used.

- **Always attach safety chains before towing.**

If needed, Roadside Assistance is available. Please see your INFINITI Warranty Information Booklet or Roadside Assistance I.D. Card for the toll-free number to call (U.S.) or INFINITI Warranty Information Booklet (Canada).

For information about towing your vehicle behind a recreational vehicle (RV), refer to "Flat towing" in the "9. Technical and consumer information" section of this manual.

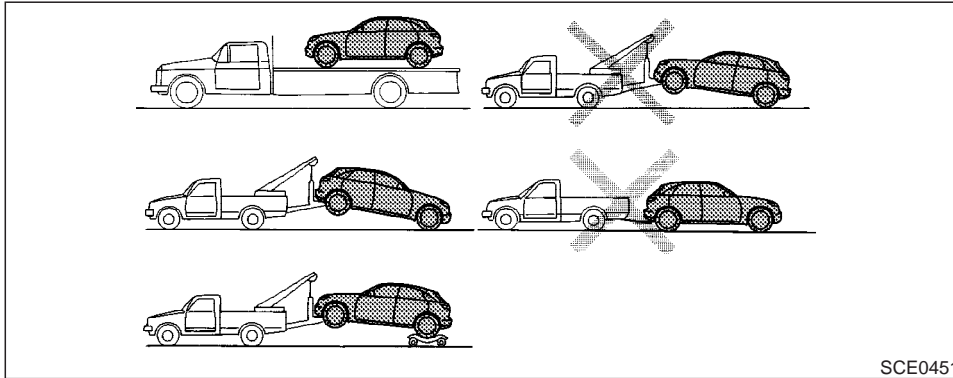

Two wheel drive models

SCE0451

TOWING RECOMMENDED BY INFINITI

Two wheel drive models

INFINITI recommends that your vehicle be towed with the driving (rear) wheels off the ground or place the vehicle on a flat bed truck as illustrated.



CAUTION

- Never tow automatic transmission models with the rear wheels on the

ground or four wheels on the ground (forward or backward) as this may cause serious and expensive damage to the transmission.

If it is necessary to tow the vehicle with the front wheels raised, always use towing dollies under the rear wheels.

- When towing rear wheel drive models with the front wheels on the ground or on towing dollies:

Turn the ignition key to the OFF position, and secure the steering wheel in a straight ahead position with a rope or similar device. Never secure the steering wheel by turning the ignition key to the LOCK position. This may damage the steering lock mechanism.

Move the selector lever to the N (Neutral) position.

- When the battery of vehicle equipped with the Intelligent Key system is discharged, your vehicle should be towed with the front wheels on towing dollies or place the vehicle on a flat bed truck.

If the speed or distance must necessarily be greater, remove the propeller shaft before towing to prevent damage to the transmission.

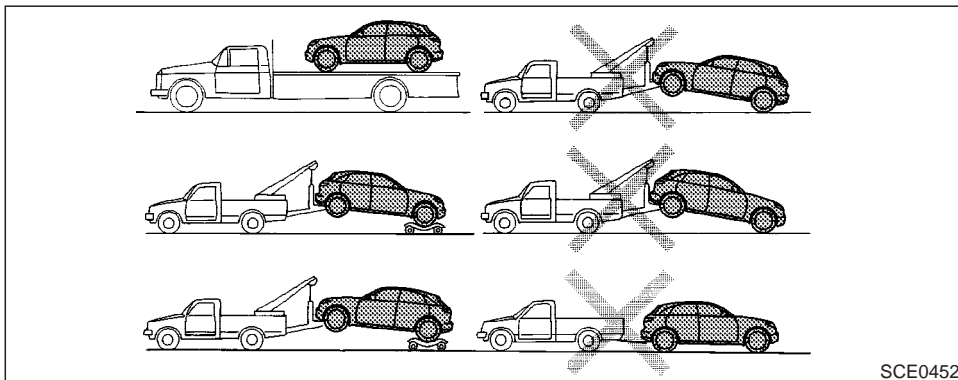

All wheel drive models

SCE0452

All wheel drive models

INFINITI recommends that towing dollies be used when towing your vehicle or the vehicle be placed on a flat bed truck as illustrated.



CAUTION

Never tow AWD models with any of the wheels on the ground as this may cause serious and expensive damage to the power train.

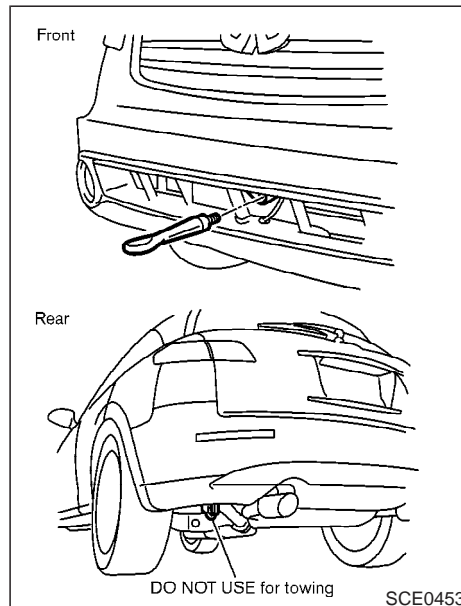

VEHICLE RECOVERY (Freeing a stuck vehicle)

Securely install the vehicle recovery hook stored with jacking tools.

Make sure that the hook is properly secured in

the stored place after use.



WARNING

- Stand clear of a stuck vehicle.
- Do not spin your tires at high speed. This could cause them to explode and result in serious injury. Parts of your vehicle could also overheat and be damaged.



CAUTION

- Tow chains or cables must be attached only to the vehicle recovery hooks or main structural members of the vehicle. Otherwise, the vehicle body will be damaged.
- Do not use the vehicle tie downs to free a vehicle stuck in sand, snow, mud, etc. Never tow the vehicle using the vehicle tie downs or recovery hooks.
- Always pull the cable straight out from the front of the vehicle.

Never pull on the hook at an angle.

- Pulling devices should be routed so they do not touch any part of the suspension, steering, brake or cooling systems.
- Pulling devices such as ropes or canvas straps are not recommended for use in vehicle towing or recovery.

Automatic transmission

To tow a vehicle equipped with an automatic transmission, an appropriate vehicle dolly **MUST** be placed under the towed vehicle's drive wheels. **Always** follow the dolly manufacturer's recommendations when using their product.

If your vehicle is stuck in sand, snow, mud, etc., use the following procedure:

1. Turn off the Vehicle Dynamic Control System.
2. Make sure the area in front and behind the vehicle is clear of obstructions.
3. Turn the steering wheel right and left to clear an area around the front tires.

4. Slowly rock the vehicle forward and backward.

Shift back and forth between R (reverse) and D (drive).

Apply the accelerator as little as possible to maintain the rocking motion.

Release the accelerator pedal before shifting between R and D.

Do not spin the tires above 35 mph (55k mh).

5. If the vehicle can not be freed after a few tries, contact a professional towing service to remove the vehicle.

MEMO

7 Appearance and care

Cleaning exterior	7-2	Floor mats	7-4
Washing.....	7-2	Seat belts	7-4
Waxing.....	7-2	Corrosion protection.....	7-5
Removing spots.....	7-3	Most common factors contributing to vehicle	
Underbody	7-3	corrosion.....	7-5
Glass	7-3	Environmental factors influence the rate of	
Aluminum alloy wheels.....	7-3	corrosion.....	7-5
Chrome parts.....	7-3	To protect your vehicle from corrosion	7-5
Cleaning interior	7-3		

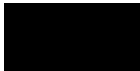

CLEANING EXTERIOR

In order to maintain the appearance of your vehicle, it is important to take proper care of it.

In the following cases, please wash your vehicle as soon as possible to protect the paint surface.

- After a rainfall to prevent possible damage from acid rain
- After driving on coastal roads
- When contaminants such as soot, bird droppings, tree sap, metal particles or bugs get on the paint surface
- When dust or mud builds up on the surface

Whenever possible, store or park your vehicle inside a garage or in a covered area.

When it is necessary to park outside, park in a shady area or protect the vehicle with a body cover.

Be careful not to scratch the paint surface when putting on or removing the body cover.

WASHING

Thoroughly rinse surface dirt off the vehicle with a wet sponge and plenty of clean water. Clean the vehicle thoroughly using a mild soap such as Nissan Car Wash, or a general purpose dishwashing liquid mixed with clean,

lukewarm (never hot) water.



CAUTION

- **Do not use strong household soap, strong chemical detergents, gasoline or solvents.**
- **Do not wash the vehicle in direct sunlight or while the vehicle body is hot, as the surface may become water-spotted.**
- **Avoid using tight-napped or rough cloths, such as washing mitts. Care must be taken when removing caked-on dirt or other foreign substances so that the paint surface is not scratched or damaged.**

Rinse the vehicle again with plenty of clean water.

Inside flanges, seams and folds on the doors, hatches and hood are particularly vulnerable to the effects of road salt. Therefore, these areas must be regularly cleaned. Make sure that the drain holes in the lower edge of the door are open. Spray water under the body

and in the wheel wells to loosen the dirt and wash away road salt.

Avoid leaving water spots on the paint surface by using a damp chamois to dry the vehicle.

WAXING

Regular waxing protects the paint surface and helps retain new vehicle appearance. After waxing, polishing is recommended to remove built-up residue and to avoid a weathered appearance.

If you wish to wax your vehicle, only use a wax specified for use over clear coats, such as Nissan Liquid or Spray Wax. Your INFINITI dealer can assist you in choosing the proper product.

- Wax your vehicle only after a thorough washing. Follow the instructions supplied with the wax.
- Do not use a wax containing any abrasives, cutting compounds or cleaners that may damage the vehicle finish.
- If the surface does not polish easily, use a road tar remover and wax again.

Machine compounding or aggressive polishing on a base coat/clear coat paint finish may dull the finish or leave swirl marks.

REMOVING SPOTS

Remove tar and oil spots, industrial dust, insects, and tree sap as quickly as possible from the surface of the paint to avoid lasting damage or staining. Special cleaning products are available at your INFINITI dealer or any automotive accessory store.

UNDERBODY

In areas where road salt is used in winter, the underbody must be cleaned regularly. This will prevent dirt and salt from building up and causing underbody and suspension corrosion. Before the winter period and again in the spring, the underseal must be checked and, if necessary, re-treated.

GLASS

Use glass cleaner to remove smoke and dust film from the glass surfaces. It is normal for glass to become coated with a film after the vehicle is parked in the hot sun. Glass cleaner and a soft cloth will easily remove this film.



CAUTION

When cleaning the inside of the window, do not use sharp-edged tools, abrasive

cleaners or chlorine based disinfectant cleaners. They could damage the electrical conductors, radio antenna elements or rear window defogger elements.

ALUMINUM ALLOY WHEELS

Wash regularly, especially during winter months in areas where road salt is used. Salt could discolor the wheel if not removed.

CHROME PARTS

Clean all chrome parts regularly with a non-abrasive chrome polish to maintain the finish.

CLEANING INTERIOR

Occasionally remove loose dust from the interior trim, plastic parts and seats using a vacuum cleaner or soft brush. Wipe the vinyl and leather surfaces with a clean, soft cloth dampened in mild soap solution, then wipe clean with a dry soft cloth. Before using any fabric protector, read the manufacturer's recommendations. Some fabric protectors contain chemicals that may stain or bleach the seat material.

Use a cloth dampened only with water, to clean the meter and gauge lens.



CAUTION

- **Never use gasoline, thinner, or any similar material.**
- **The leather seats should be regularly coated with a leather wax like saddle soap. Never use car wax.**
- **Never use fabric protectors unless recommended by the manufacturer.**
- **Do not use glass or plastic cleaner on meter or gauge lens covers. It may damage the lens cover.**

FLOOR MATS

The use of Genuine INFINITI floor mats can extend the life of your vehicle carpet and make it easier to clean the interior. **No matter what mats are used, be sure they are fitted for your vehicle and are properly positioned in the footwell to prevent interference with pedal operation.** Mats should be maintained with regular cleaning and replaced if they become excessively worn.

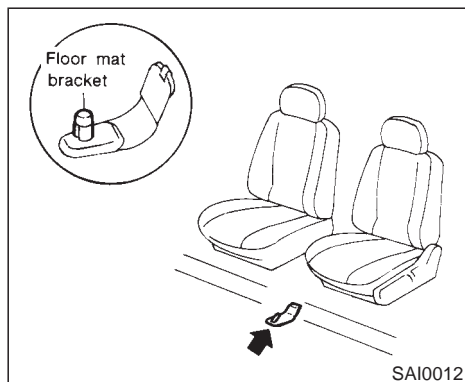

Floor mat positioning aid (Driver side only)

This model includes a front floor mat bracket to act as a floor mat positioning aid. INFINITI floor mats have been specially designed for your vehicle model. The driver's side floor mat has a grommet hole incorporated in it. Simply position the mat by placing the floor mat bracket through the floor mat grommet hole while centering the mat in the floorpan contour.

Periodically check to make certain that the mats are properly positioned.

SEAT BELTS

The seat belts can be cleaned by wiping them with a sponge dampened in a mild soap solution. Allow the belts to dry completely before using them.



WARNING

Do not allow wet belts to roll up in the retractor. NEVER use bleach, dye, or chemical solvents since these may severely weaken the seat belt webbing.

CORROSION PROTECTION

MOST COMMON FACTORS CONTRIBUTING TO VEHICLE CORROSION:

- The accumulation of moisture-retaining dirt and debris in body panel sections, cavities, and other areas.
- Damage to paint and other protective coatings caused by gravel and stone chips or minor traffic accidents.

ENVIRONMENTAL FACTORS INFLUENCE THE RATE OF CORROSION:

Moisture

Accumulation of sand, dirt and water on the vehicle body underside can accelerate corrosion. Wet floor coverings will not dry completely inside the vehicle, and should be removed for drying to avoid floor panel corrosion.

Relative humidity

Corrosion will be accelerated in areas of high relative humidity, especially those areas where the temperatures stay above freezing and where atmospheric pollution exists and road salt is used.

Temperature

A temperature increase will accelerate the rate of corrosion to those parts which are not well ventilated.

Air pollution

Industrial pollution, the presence of salt in the air in coastal areas, or heavy road salt use will accelerate the corrosion process. Road salt will also accelerate the disintegration of paint surfaces.

TO PROTECT YOUR VEHICLE FROM CORROSION:

- Wash and wax your vehicle often to keep the vehicle clean.
- Always check for minor damage to the paint and repair it as soon as possible.
- Keep drain holes at the bottom of the doors open to avoid water accumulation.
- Check the underbody for accumulation of sand, dirt or salt. If present, wash with water as soon as possible.



CAUTION

- **NEVER** remove dirt, sand or other debris from the passenger compartment by washing it out with a hose. Remove dirt with a vacuum cleaner or broom.
- **Never** allow water or other liquids to come in contact with electronic components inside the vehicle as this may damage them.

Chemicals used for road surface de-icing are extremely corrosive. They accelerate corrosion and deterioration of underbody components such as the exhaust system, fuel and brake lines, brake cables, floor pan and fenders.

In winter, the underbody must be cleaned periodically.

For additional protection against rust and corrosion, which may be required in some areas, consult your local INFINITI dealer.

MEMO

8 Maintenance and do-it-yourself

Maintenance requirements.....	8-2	Windshield wiper blades	8-20
General maintenance.....	8-2	Cleaning	8-20
Explanation of general maintenance items	8-3	Replacing.....	8-21
Maintenance precautions	8-5	Rear window wiper blade.....	8-22
Engine compartment check locations	8-7	Parking brake and brake pedal.....	8-22
Engine cooling system	8-9	Checking parking brake	8-22
Checking engine coolant level	8-9	Checking brake pedal	8-22
Changing engine coolant	8-10	Brake booster	8-23
Engine oil	8-11	Fuses.....	8-23
Checking engine oil level	8-11	Engine compartment	8-24
Changing engine oil and filter	8-12	Passenger compartment	8-25
Automatic transmission fluid	8-15	Keyfob battery replacement	8-26
Power steering fluid	8-15	Lights.....	8-27
Brake fluid	8-15	Headlights.....	8-28
Window washer fluid	8-16	Exterior and interior lights	8-28
Battery	8-17	Wheels and tires	8-32
Jump starting.....	8-18	Tire pressure	8-32
Drive belts	8-18	Tire labeling.....	8-34
Spark plugs	8-19	Types of tires.....	8-36
Replacing spark plugs.....	8-19	Tire chains.....	8-37
Air cleaner	8-20	Changing wheels and tires.....	8-38

MAINTENANCE REQUIREMENTS

Your new INFINITI has been designed to have minimum maintenance requirements with longer service intervals to save you both time and money. However, some day-to-day and regular maintenance is essential to maintain your INFINITI's good mechanical condition, as well as its emission and engine performance.

It is the owner's responsibility to make sure that the specified maintenance and the general maintenance are performed.

As the vehicle owner, you are the only one who can ensure that your vehicle receives the proper maintenance care. You are a vital link in the maintenance chain.

Scheduled maintenance:

For your convenience, both required and optional scheduled maintenance items are described and listed in your "INFINITI Service and Maintenance Guide". You must refer to that guide to ensure that necessary maintenance is performed on your INFINITI at regular intervals.

General maintenance:

General maintenance includes those items which should be checked during normal day-to-day operation. They are essential for proper vehicle operation. It is your responsibility to

perform these maintenance procedures regularly as prescribed.

Performing general maintenance checks requires minimal mechanical skill and only a few general automotive tools.

These checks or inspections can be done by you, a qualified technician, or, if you prefer, an INFINITI dealer.

Where to go for service:

If maintenance service is required or your vehicle appears to malfunction, have the systems checked and serviced by an INFINITI dealer.

INFINITI technicians are well-trained specialists and are kept up to date with the latest service information through technical bulletins, service tips, and in-dealership information systems. They are completely qualified to work on INFINITI vehicles **before** work begins.

You can be confident that your INFINITI dealer's service department performs the best job to meet the maintenance requirements on your vehicle — in a reliable and economic way.

GENERAL MAINTENANCE

During the normal day-to-day operation of the vehicle, general maintenance should be performed regularly as prescribed in this section. If you detect any unusual sounds, vibrations or smell, be sure to check for the cause or have your INFINITI dealer perform it promptly. In addition, you should notify your INFINITI dealer if you think the repairs are required.

When performing any checks or maintenance work, closely observe the "Maintenance precautions" later in this section.

EXPLANATION OF GENERAL MAINTENANCE ITEMS

Additional information on the following items with “*” is found later in this section.

Outside the vehicle

The maintenance items listed here should be performed from time to time, unless otherwise specified.

Doors and engine hood: Check that all doors and the engine hood operate properly. Also ensure that all latches lock securely. Lubricate hinges and latches if necessary. Make sure that the secondary latch keeps the hood from opening when the primary latch is released.

When driving in areas using road salt or other corrosive materials, check lubrication frequently.

Lights*: Clean the headlights on a regular basis. Make sure that the headlights, stop lights, tail lights, turn signal lights, and other lights are all operating properly and installed securely. Also check headlight aim.

Road wheel nuts (lug nuts): When checking the tires, make sure no wheel nuts are missing, and check for any loose wheel nuts. Tighten if necessary.

Tires*: Check the pressure with a gauge often and always prior to long distance trips. If necessary, adjust the pressure in all tires, including the spare, to the specified pressure. Check carefully for damage, cuts or excessive wear.

Tire rotation*:

Sedan: The tires should be rotated every 7,500 miles (12,000 km) to minimize tire wear variation.

Coupe: The tires cannot be rotated.

Tire, wheel alignment and balance: If the vehicle should pull to either side while driving on a straight and level road, or if you detect uneven or abnormal tire wear, there may be a need for wheel alignment.

If the steering wheel or seat vibrates at normal highway speeds, wheel balancing may be needed.

- For additional information regarding tires, refer to “Important Tire Safety Information” (US) or “Tire Safety Information” (Canada) in the Warranty Information Booklet.

Windshield: Clean the windshield on a regular basis. Check the windshield at least every six months for cracks or other damage. Have a damaged windshield repaired by a qualified repair facility.

Windshield wiper blades*: Check for cracks or wear if they do not wipe properly.

Inside the vehicle

The maintenance items listed here should be checked on a regular basis, such as when performing periodic maintenance, cleaning the vehicle, etc.

Accelerator pedal: Check the pedal for smooth operation and make sure the pedal does not catch or require uneven effort. Keep the floor mat away from the pedal.

Automatic transmission P (Park) mechanism: On a fairly steep hill check that your vehicle is held securely with the selector lever in the P (Park) position without applying any brakes.

Brake pedal*: Check the pedal for smooth operation and make sure it has the proper distance under it when depressed fully. Check the brake booster function. Be sure to keep the floor mat away from the pedal.

Brakes: Check that the brakes do not pull the vehicle to one side when applied.

Clutch pedal*: Make sure the pedal operates smoothly and check that it has the proper free play.

Parking brake*: Check that the lever has the proper travel and confirm that your vehicle is

held securely on a fairly steep hill with only the parking brake applied.

Seats: Check seat position controls such as seat adjusters, seatback recliner, etc. to ensure they operate smoothly and that all latches lock securely in every position. Check that the head restraints move up and down smoothly and that the locks (if so equipped) hold securely in all latched positions.

Seat belts: Check that all parts of the seat belt system (For example, buckles, anchors, adjusters and retractors) operate properly and smoothly, and are installed securely. Check the belt webbing for cuts, fraying, wear or damage.

Steering wheel: Check for changes in the steering conditions, such as excessive free play, hard steering or strange noises.

Warning lights and chimes: Make sure that all warning lights and chimes are operating properly.

Windshield defroster: Check that the air comes out of the defroster outlets properly and in sufficient quantity when operating the heater or air conditioner.

Windshield wiper and washer*: Check that the wipers and washer operate properly and that the wipers do not streak.

Under the hood and the vehicle

The maintenance items listed here should be checked periodically (For example, each time you check the engine oil or refuel).

Battery*: Check the fluid level in each cell. It should be between the MAX and MIN lines. Vehicles operated in high temperatures or under severe conditions require frequent checks of the battery fluid level.

Brake and clutch fluid level*: Make sure that the brake and clutch fluid levels are between the MAX and MIN lines on the reservoir.

Engine coolant level*: Check the coolant level when the engine is cold.

Engine drive belts*: Make sure that no belt is frayed, worn, cracked or oily.

Engine oil level*: Check the level after parking the vehicle on a level location and turning off the engine. (Wait at least 10 minutes for the oil to drain back into the oil pan.)

Exhaust system: Make sure there are no loose supports, cracks or holes. If the sound of the exhaust seems unusual or there is a smell of exhaust fumes, immediately locate the trouble and correct it. See “Precautions when starting and driving” in the “5. Starting and

driving” section for exhaust gas (Carbon monoxide).

Fluid leaks: Check under the vehicle for fuel, oil, water or other fluid leaks after the vehicle has been parked for a while. Water dripping from the air conditioner after use is normal. If you should notice any leaks or if gasoline fumes are evident, check for the cause and have it corrected immediately.

Power steering fluid level* and lines: Check the level when the fluid is cold and the engine is turned off. Check the lines for proper attachment, leaks, cracks, etc.

Radiator and hoses: Check the front of the radiator and clean off any dirt, insects, leaves, etc., that may have accumulated. Make sure the hoses have no cracks, deformation, deterioration or loose connections.

Underbody: The underbody is frequently exposed to corrosive substances such as those used on icy roads or to control dust. It is very important to remove these substances, otherwise rust will form on the floor pan, frame, fuel lines and around the exhaust system. At the end of winter, the underbody should be thoroughly flushed with plain water, being careful to clean those areas where mud and dirt may accumulate. For additional information, see

“Cleaning exterior” in the “7. Appearance and care” section.

Windshield washer fluid*: Check that there is adequate fluid in the tank.

MAINTENANCE PRECAUTIONS

When performing any inspection or maintenance work on your vehicle, always take care to prevent serious accidental injury to yourself or damage to the vehicle. The following are general precautions which should be closely observed.



WARNING

- **Park the vehicle on a level surface, apply the parking brake securely and block the wheels to prevent the vehicle from moving. Move the selector lever to P (Park) position.**
- **Be sure the ignition key is OFF or LOCK when performing any parts replacement or repairs.**
- **Your vehicle is equipped with an automatic engine cooling fan. It may come on at any time without warning, even if the ignition key is in the OFF position and the engine is not running. To avoid injury, always disconnect the negative battery cable before working near the fan.**
- **If you must work with the engine**

running, keep your hands, clothing, hair and tools away from moving fans, belts and any other moving parts.

- It is advised to secure or remove any loose clothing and any jewelry, such as rings, watches, etc. before working on your vehicle.
- Always wear eye protection whenever you work on your vehicle.
- If you must run the engine in an enclosed space such as a garage, be sure there is proper ventilation for exhaust gases to escape.
- Never get under the vehicle while it is supported only by a jack. If it is necessary to work under the vehicle, support it with safety stands.
- Keep smoking materials, flame and sparks away from fuel and the battery.
- On gasoline engine models with the Multiport Fuel Injection (MFI) System,

the fuel filter or fuel lines should be serviced by an INFINITI dealer because the fuel lines are under high pressure even when the engine is off.



CAUTION

- Do not work under the hood while the engine is hot. Turn off the engine and wait until it cools down.
- Never connect or disconnect either the battery or any transistorized component connector while the ignition key is on.
- Never leave any engine or automatic transmission related component harness connector disconnected while the ignition key is on.
- Avoid direct contact with used engine oil and coolant. Improperly disposed engine oil, engine coolant and/or other vehicle fluids can hurt the environment. Always conform to local

regulations for disposal of vehicle fluid.

This “8. Maintenance and do-it-yourself” section gives instructions regarding only those items which are relatively easy for an owner to perform.

A genuine INFINITI Service Manual is also available. See “Owner’s Manual/Service Manual order information” in the “9. Technical and consumer information” section.

You should be aware that incomplete or improper servicing may result in operating difficulties or excessive emissions, and could affect your warranty coverage. **If in doubt about any servicing, have it done by your INFINITI dealer.**

ENGINE COMPARTMENT CHECK LOCATIONS

VQ35DE engine

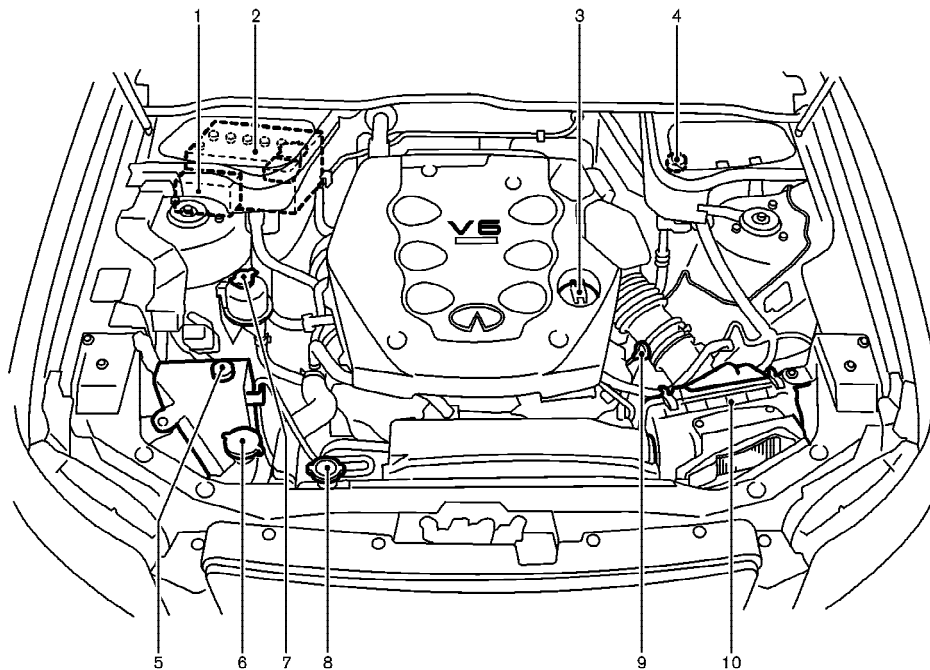

SDI1524

VK45DE engine

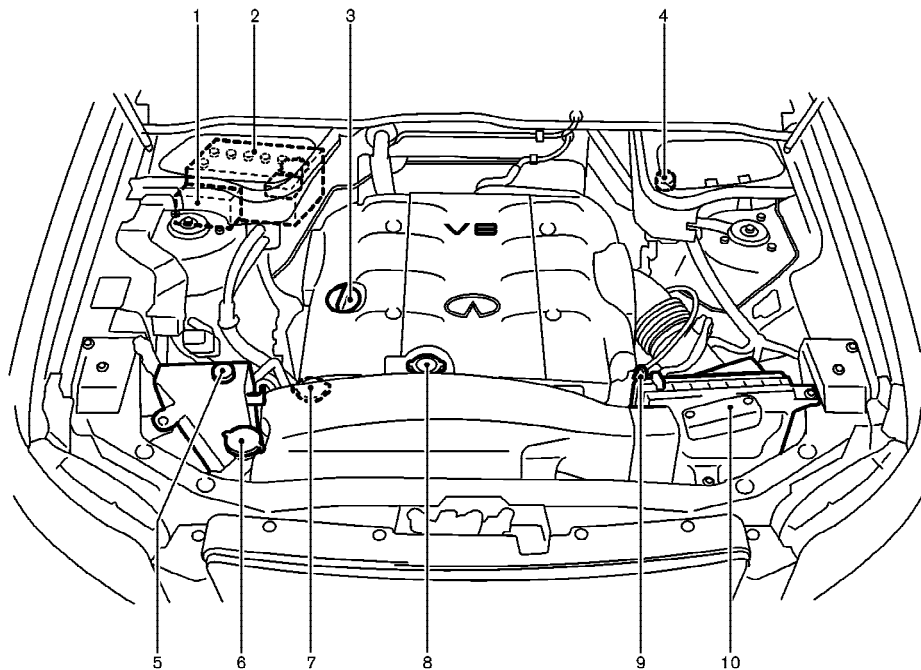

1. Fuse/fusible link holder
2. Battery
3. Engine oil filler cap
4. Brake fluid reservoir
5. Engine coolant reservoir
6. Windshield washer fluid reservoir
7. Power steering fluid reservoir
8. Radiator filler cap
9. Engine oil dipstick
10. Air cleaner

SDI1531

ENGINE COOLING SYSTEM

The engine cooling system is filled at the factory with a high-quality, year-round, anti-freeze coolant solution. The anti-freeze solution contains rust and corrosion inhibitors, therefore additional cooling system additives are not necessary.

CAUTION

When adding or replacing coolant, be sure to use only a Genuine NISSAN Long Life Antifreeze/Coolant or equivalent with the proper mixture ratio of 50% anti-freeze and 50% demineralized water/distilled water. The use of other types of coolant solutions may damage your engine cooling system.

Outside temperature down to		Anti-freeze	Demineralized water/ distilled water
°C	°F		
-35	-30	50%	50%

WARNING

- Never remove the radiator cap when the engine is hot. Serious burns could be caused by high pressure fluid escaping from the radiator. Wait until the engine and radiator cool down.
- See “If your vehicle overheats” in the “6. In case of emergency” section.
- The radiator is equipped with a pressure cap. To prevent engine damage, use only a genuine NISSAN radiator cap.

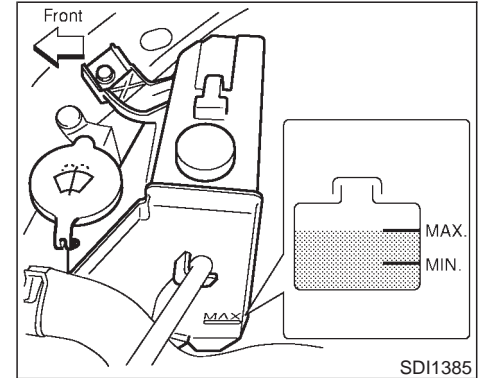

CHECKING ENGINE COOLANT LEVEL

Check the coolant level in the reservoir tank when the engine is cold. If the coolant level is below MIN, add coolant up to the MAX level. If the reservoir tank is empty, check the coolant level in the radiator **when the engine is cold**. If there is insufficient coolant in the radiator, fill the radiator with coolant up to the filler opening and also add it to the reservoir tank up to the MAX level.

If the engine cooling system frequently requires coolant, have it checked by your INFINITI dealer.

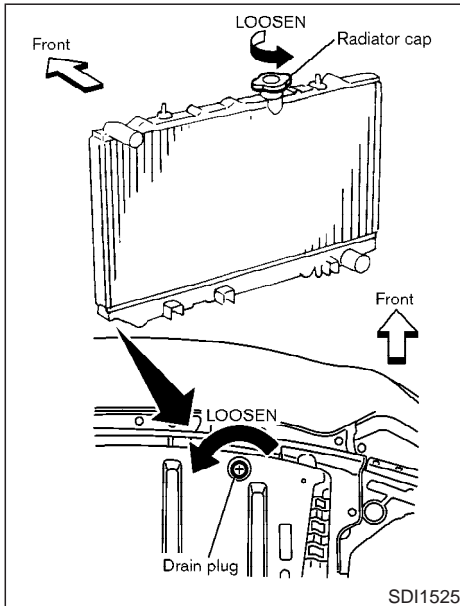

CHANGING ENGINE COOLANT

- Major cooling system repairs should be performed by your INFINITI dealer. The service procedures can be found in the appropriate INFINITI Service Manual.

8-10 Maintenance and do-it-yourself

- Improper servicing can result in reduced heater performance and engine overheating.



WARNING

- **To avoid being scalded, never change the coolant when the engine is hot.**
 - **Never remove the radiator cap when the engine is hot. Serious burns could be caused by high pressure fluid escaping from the radiator.**
 - **Avoid direct skin contact with used coolant. If skin contact is made, wash thoroughly with soap or hand cleaner as soon as possible.**
 - **Keep coolant out of reach of children and pets.**
1. Open radiator drain plug at the bottom of radiator, and remove radiator filler cap.

3. Fill the radiator slowly with the proper mixture of anti-freeze solution and demineralized water/distilled water. Fill the reservoir tank up to the MAX level. Then install the radiator filler cap.
4. Start the engine and warm it up until it reaches normal operating temperature. Then race the engine 2 or 3 times under no load. Watch the engine coolant temperature gauge for signs of overheating.
5. Stop the engine. After it completely cools down, refill the radiator up to the filler opening. Fill the reservoir tank up to the MAX level. Check the drain plug for any sign of leakage.
6. Recheck the coolant level after the vehicle has been driven for a day.

ENGINE OIL

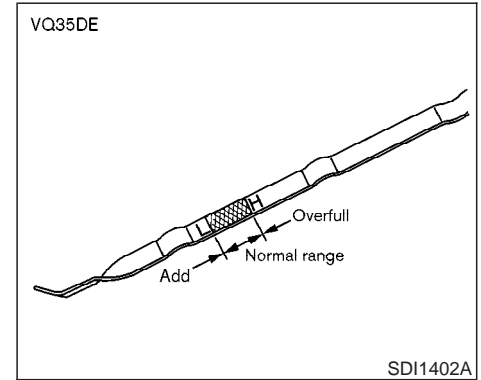
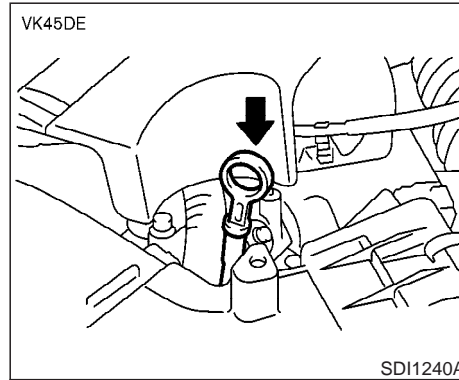
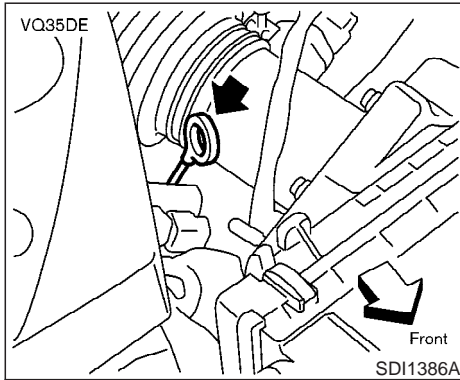

CHECKING ENGINE OIL LEVEL

1. Park the vehicle on a level surface and apply parking brake.
2. Run the engine until it reaches operating temperature.
3. Turn off the engine. **Wait more than 15 minutes for the oil to drain back into the oil pan.**
4. Remove the dipstick and wipe it clean. Reinsert it all the way.

5. Remove the dipstick again and check the oil level. It should be between the H and L marks. If the oil level is below the L mark, remove the oil filler cap and pour recommended oil through the opening. **Do not overfill.**
6. Recheck oil level with dipstick.

It is normal to add some oil between oil maintenance intervals or during the break-in period, depending on the severity of operating conditions.



CAUTION

Oil level should be checked regularly. Operating with insufficient amount of oil can damage the engine, and such damage is not covered by warranty.

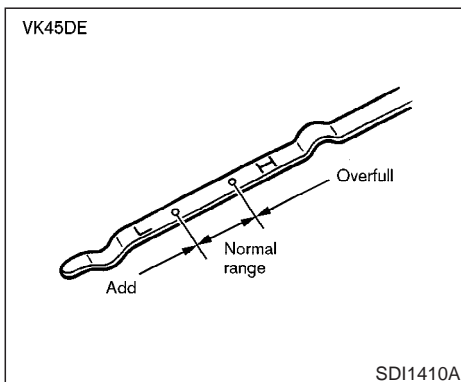

CHANGING ENGINE OIL AND FILTER

Change the engine oil and filter according to the maintenance intervals shown in the INFINITI Service and Maintenance Guide.

Vehicle set-up

1. Park the vehicle on a level surface and apply the parking brake.
2. Run the engine until it reaches operating temperature.
3. Turn the engine off and wait more than 15 minutes.
4. Raise and support the vehicle using a suitable floor jack and safety jack stands.
 - Place the safety jack stands under the vehicle jack-up points.
 - A suitable adapter should be attached to the jack stand saddle.
5. Remove the plastic engine undercover.
 - a. Remove the small plastic clips at the rear side of the undercover.
 - b. Then remove the other bolts that hold the undercover in place.



CAUTION

Make sure the correct lifting and support points are used to avoid vehicle damage.

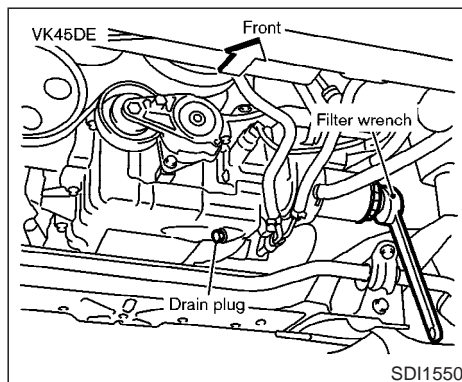
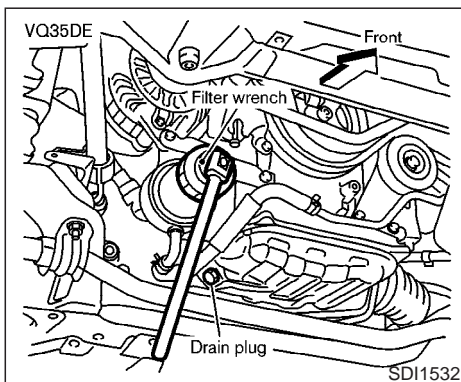

Engine oil and filter

1. Place a large drain pan under the drain plug.
2. Remove the oil filler cap.
3. Remove the drain plug with a wrench and completely drain the oil.



CAUTION

Be careful not to burn yourself, as the engine oil is hot.

- Waste oil must be disposed of properly.

- **Check your local regulations.**
4. Loosen the oil filter with an oil filter wrench. Remove the oil filter by turning it by hand.
 5. Wipe the engine oil filter mounting surface with a clean rag.

Be sure to remove any old rubber gasket remaining on the mounting surface of the engine.
 6. Coat the gasket on the new filter with clean engine oil.
 7. Screw in the oil filter clockwise until a slight resistance is felt, then tighten additionally more than 2/3 turn.

Oil filter tightening torque:

**11 to 15 ft-lb
(14.7 to 20.5 N-m)**

8. Clean and re-install the drain plug with a new washer. Securely tighten the drain plug with a wrench.

Drain plug tightening torque:

**22 to 29 ft-lb
(29 to 39 N-m)**

Do not use excessive force.

9. Refill engine with recommended oil and install the cap securely.



CAUTION

The dipstick must be inserted in place to prevent oil spillage from the dipstick hole while filling the engine with oil.

See “Capacities and recommended fuel/lubricants” in the “9. Technical and consumer information” section for drain and refill capacity. The drain and refill capacity depends on the oil temperature and drain time. Use these specifications for reference only. Always use the dipstick to determine the proper amount of oil in the engine.



CAUTION

When filling oil, do not pull out the dipstick.

10. Start the engine and check for leakage around the drain plug and the oil filter. Correct as required.
11. Turn the engine off and wait more than 10 minutes. Check the oil level with the dipstick. Add engine oil if necessary.

8-14 Maintenance and do-it-yourself

After the operation

1. Install the engine undercover into position as the following steps.
 - a. Pull the center of the small plastic clip out.
 - b. Hold the engine undercover into position.
 - c. Insert the clips through the undercover into the hole in the frame, then push the center of the clip in to lock the clip in place.
 - d. Install the other bolts that hold the undercover in place. Be careful not to strip the bolts or over-tighten them.
2. Lower the vehicle carefully to the ground.
3. Dispose of waste oil and filter properly.



WARNING

- **Prolonged and repeated contact with used engine oil may cause skin cancer.**
- **Try to avoid direct skin contact with used oil. If skin contact is made, wash thoroughly with soap or hand cleaner as soon as possible.**

- **Keep used engine oil out of reach of children.**

AUTOMATIC TRANSMISSION FLUID

If checking or replacement is required, we recommend your INFINITI dealer for servicing.

CAUTION

- Use only Genuine Nissan Matic J ATF. Do not mix with other fluids.
- Using automatic transmission fluid other than Genuine Nissan Matic J ATF will cause deterioration in driveability and automatic transmission durability, and may damage the automatic transmission, which is not covered by the INFINITI new vehicle limited warranty.

The specified automatic transmission fluid is also described on caution labels located in the engine compartment.

POWER STEERING FLUID

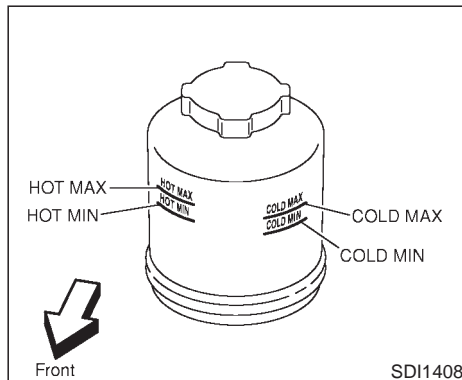

Check the fluid level in the reservoir tank.

The fluid level should be checked using the HOT range at fluid temperatures of 122 to 176°F (50 to 80°C) or using the COLD range at fluid temperatures of 32 to 86°F (0 to 30°C).

CAUTION

- Do not overfill.
- Use Genuine NISSAN PSF or equivalent.

BRAKE FLUID

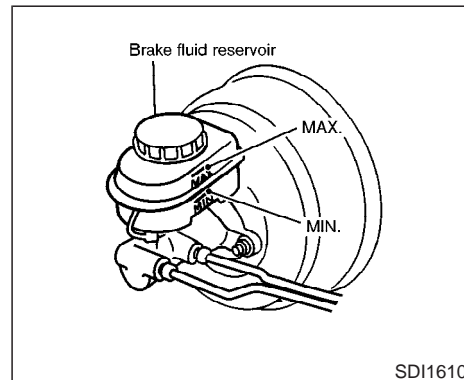

Check the fluid level in the reservoir. If the fluid is below the MIN line or the brake warning light comes on, add Genuine NISSAN Super Heavy Duty Brake Fluid or equivalent to **DOT 3** fluid up to the MAX line. If fluid must be added frequently, the system should be thoroughly checked by your INFINITI dealer.

WARNING

Use only new fluid. Old, inferior, or contaminated fluid may damage the brake

system. Do not add synthetic brake fluid. The use of improper fluids can damage the brake system and affect the vehicle's stopping ability.

CAUTION

Do not spill the fluid on painted surfaces. This will damage the paint. If fluid is spilled, wash with water.

WINDOW WASHER FLUID

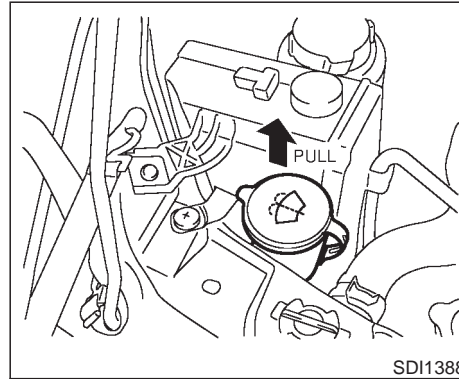

Add fluid when the low washer fluid warning light comes on. Add a washer solvent to the water for better cleaning. In the winter season, add a windshield washer anti-freeze. Follow the manufacturer's instructions for the mixture ratio.

WARNING

Anti-freeze is poisonous and should be stored carefully in marked containers out of the reach of children.

CAUTION

Do not substitute engine anti-freeze coolant for window washer solution. This may result in damage to the paint.

BATTERY

- Keep the battery surface clean and dry. Any corrosion should be washed off with a solution of baking soda and water.
- Make certain the terminal connections are clean and securely tightened.
- If the vehicle is not to be used for 30 days or longer, disconnect the (—) negative battery terminal cable to prevent discharging it.



WARNING

- Do not expose the battery to flames or electrical sparks. Hydrogen gas generated by battery action is explosive. Do not allow battery fluid to contact your skin, eyes, fabrics, or painted surfaces. After touching a battery or battery cap, do not touch or rub your eyes. Thoroughly wash your hands. If you get acid on your eyes, skin or clothing, immediately flush with water for at least 15 minutes and seek medical attention.
- Do not operate the vehicle if the battery fluid is low. Low battery fluid can cause a higher load on the battery

which can generate heat, reduce battery life, and in some cases lead to an explosion.

- **When working on or near a battery, always wear suitable eye protection and remove all jewelry.**
- **Battery posts, terminals and related accessories contain lead and lead compounds. Wash hands after handling.**
- **Keep the battery out of the reach of children.**

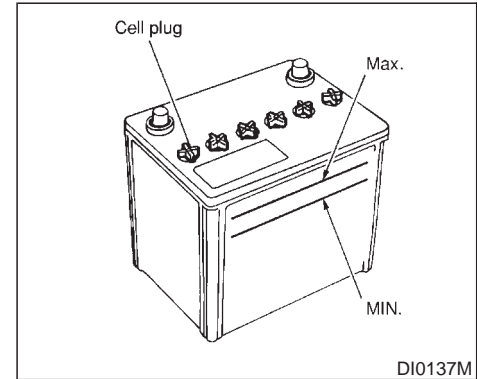

Check the fluid level in each cell. It should be between the MAX and MIN lines.

If it is necessary to add fluid, add only distilled water to bring the level to the indicator in each filler opening. **Do not overfill.**

Vehicles operated in high temperatures or under severe conditions require frequent checks of the battery fluid level.

1. Remove the cell plugs.
2. Add distilled water up to the MAX level.
3. Tighten cell plugs.

DRIVE BELTS

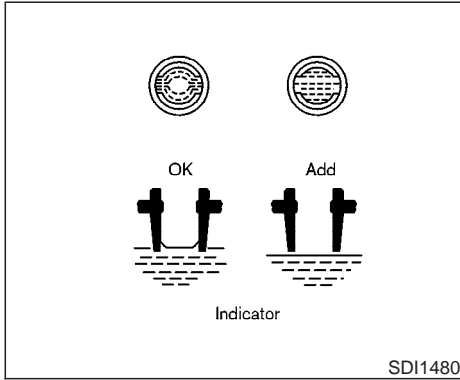

JUMP STARTING

If jump starting is necessary, see “Jump starting” in the “6. In case of emergency” section. If the engine does not start by jump starting, the battery may have to be replaced. Contact your INFINITI dealer.

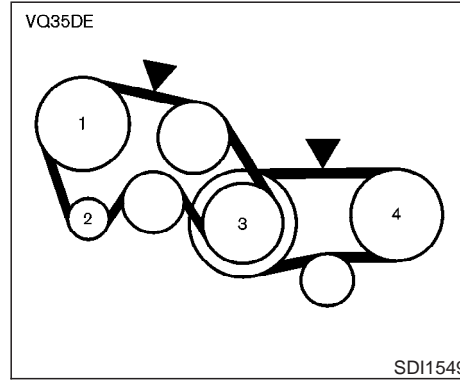

1. Power steering fluid pump
 2. Alternator
 3. Crankshaft pulley
 4. Air conditioner compressor
- ▼: Tension checking points

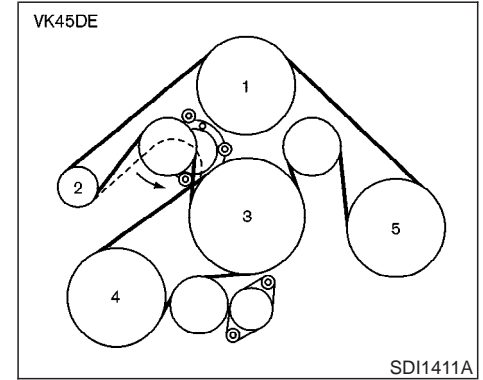

1. Water pump
2. Alternator
3. Crankshaft pulley
4. Power steering fluid pump
5. Air conditioner compressor

SPARK PLUGS



WARNING

Be sure the ignition key is in the **OFF** or **LOCK** position. The engine could rotate unexpectedly.



WARNING

Be sure the engine and ignition switch are off and that the parking brake is engaged securely.



CAUTION

Be sure to use the correct socket to remove the spark plugs. An incorrect socket can damage the spark plugs.

1. Visually inspect each belt for signs of unusual wear, cuts, fraying, oil adhesion or looseness. If the belt is in poor condition or loose, have it replaced or adjusted by your INFINITI dealer.
2. Have the belts checked regularly for condition and tension in accordance with the maintenance schedule in the INFINITI service and maintenance guide.

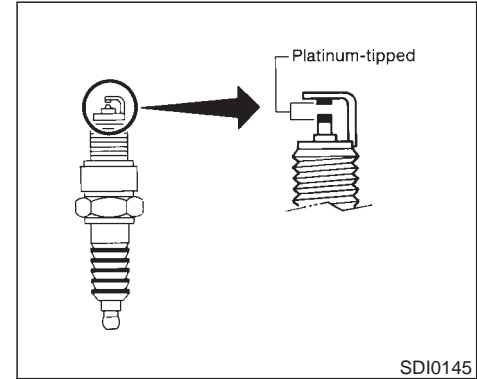

REPLACING SPARK PLUGS

If replacement is required, see your INFINITI dealer for servicing.

Platinum-tipped spark plugs

It is not necessary to replace the platinum-tipped spark plugs as frequently as the conventional type spark plugs since they will last much longer. Follow the maintenance schedule but, do not reuse them by cleaning or regapping.

Always replace with recommended platinum-tipped spark plugs.

AIR CLEANER

If maintenance is required, see your INFINITI dealer for servicing.

The filter element should not be cleaned and reused. Replace it according to the maintenance intervals. See the INFINITI Service and Maintenance Guide for maintenance intervals. When replacing the filter, wipe the inside of the air cleaner housing and the cover with a damp cloth.



WARNING

- **Operating the engine with the air cleaner removed can cause you or others to be burned. The air cleaner not only cleans the air, it stops flame if the engine backfires. If it is not there, and the engine backfires, you could be burned. Do not drive with the air cleaner removed and be careful when working on the engine with the air cleaner removed.**
- **Never pour fuel into the throttle body or attempt to start the engine with the air cleaner removed. Doing so could result in serious injury.**

WINDSHIELD WIPER BLADES



CAUTION

- **After wiper blade replacement, return the wiper arm to its original position. Otherwise it may be damaged when the engine hood is opened.**
- **Make sure the wiper blade contacts the glass, otherwise the arm may be damaged from wind pressure.**
- **Worn windshield wiper blades can damage the windshield and impair driver vision.**

gent. Then rinse the blade with clear water. If your windshield is still not clear after cleaning the blades and using the wiper, replace the blades.

CLEANING

If your windshield is not clear after using the windshield washer or if a wiper blade chatters when running, wax or other material may be on the blade or windshield.

Clean the outside of the windshield with a washer solution or a mild detergent. Your windshield is clean if beads do not form when rinsing with clear water.

Clean the blade by wiping it with a cloth soaked in a washer solution or a mild deter-

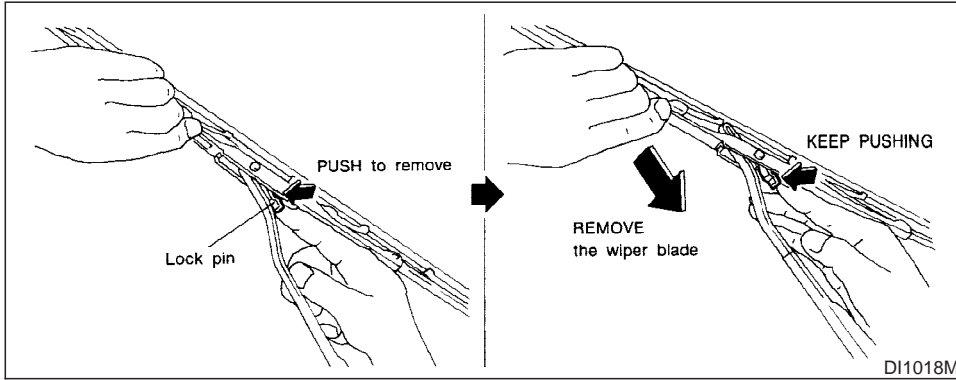

REPLACING

Replace the wiper blades if they are worn.

1. Pull the wiper arm.
2. Push the lock pin, then remove the wiper blade.
3. Insert the new wiper blade to the wiper arm until a click sounds.

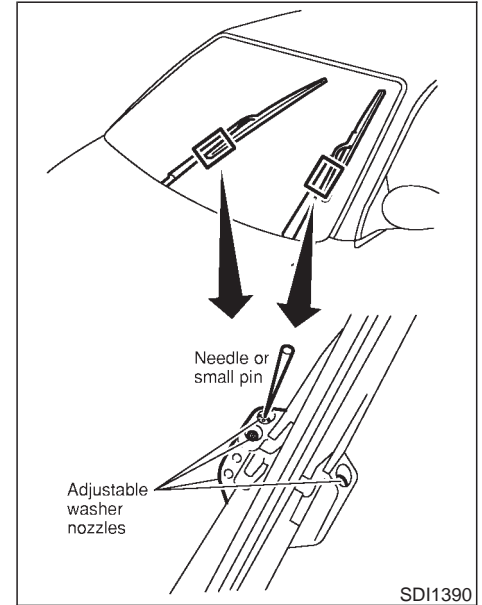

If necessary, clean the windshield washer nozzle with a needle or small pin.

REAR WINDOW WIPER BLADE

Contact your INFINITI dealer if checking or replacement is required.

PARKING BRAKE AND BRAKE PEDAL

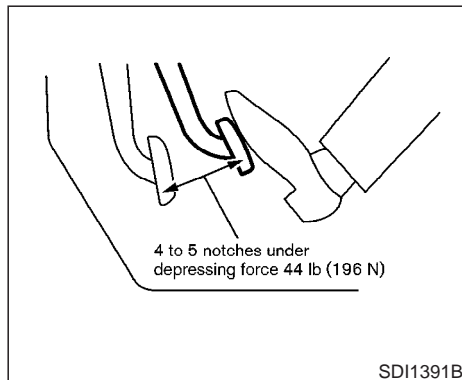

CHECKING PARKING BRAKE

From the released position, depress the parking brake pedal slowly and firmly, and check the distance between the initial and final position of the pedal. If it is out of the range shown above, see your INFINITI dealer.

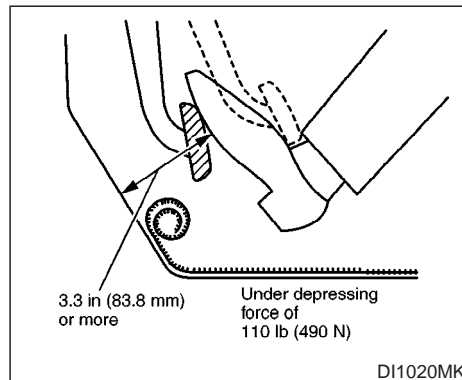

CHECKING BRAKE PEDAL

With the engine running, check the distance between the upper surface of the pedal and the metal floor. If it is out of the range shown above, see your INFINITI dealer.

Self-adjusting brakes

Your vehicle is equipped with self-adjusting brakes.

The disc-type brakes self-adjust every time the brake pedal is applied.



WARNING

See your INFINITI dealer and have it checked if the brake pedal height does not return to normal.

Brake pad wear indicators

The disc brake pads on your vehicle have audible wear indicators. When a brake pad requires replacement, it will make a high pitched scraping or screeching sound when the vehicle is in motion whether or not the brake pedal is depressed. Have the brakes checked as soon as possible if the wear indicator sound is heard.

Under some driving or climate conditions, occasional brake squeak, squeal or other noise may be heard. Occasional brake noise during light to moderate stops is normal and does not affect the function or performance of the brake system.

Proper brake inspection intervals should be followed. For additional information, see the appropriate maintenance log shown in the INFINITI Service and Maintenance Guide.

BRAKE BOOSTER

Check the brake booster function as follows:

1. With the engine off, press and release the brake pedal several times. When brake pedal movement (distance of travel) remains the same from one pedal application to the next, continue on to the next step.
2. While depressing the brake pedal, start the engine. The pedal height should drop a little.
3. With the brake pedal depressed, stop the engine. Keeping the pedal depressed for about 30 seconds, the pedal height should not change.
4. Run the engine for one minute without depressing the brake pedal, then turn it off. Depress the brake pedal several times. The pedal travel distance will decrease gradually with each depression as the vacuum is released from the booster.

If the brakes do not operate properly, see your INFINITI dealer.

FUSES



CAUTION

Never use a fuse of higher or lower amperage rating than that specified on the fuse box cover. This could damage the electrical system or cause a fire.

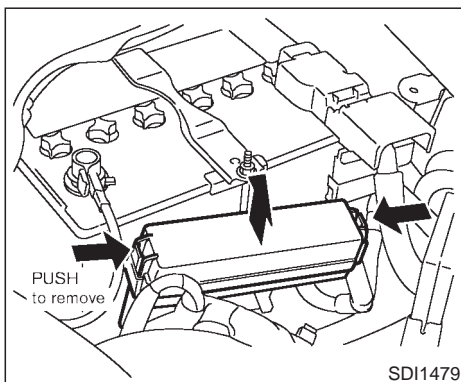

6. If a new fuse also opens, have the electrical system checked and repaired by your INFINITI dealer.

Fusible links

If any electrical equipment does not operate and fuses are in good condition, check the fusible links. If any of these fusible links are melted, replace only with genuine NISSAN parts.

ENGINE COMPARTMENT

If any electrical equipment does not operate, check for an open fuse.

1. Be sure the ignition key and headlight switch are OFF.
2. Open the engine hood and remove the cover on the battery and the fuse/fusible link holder.
3. Remove the fuse/fusible link holder cover.
4. Remove the fuse with the fuse puller.
5. If the fuse is open, replace it with a new fuse.

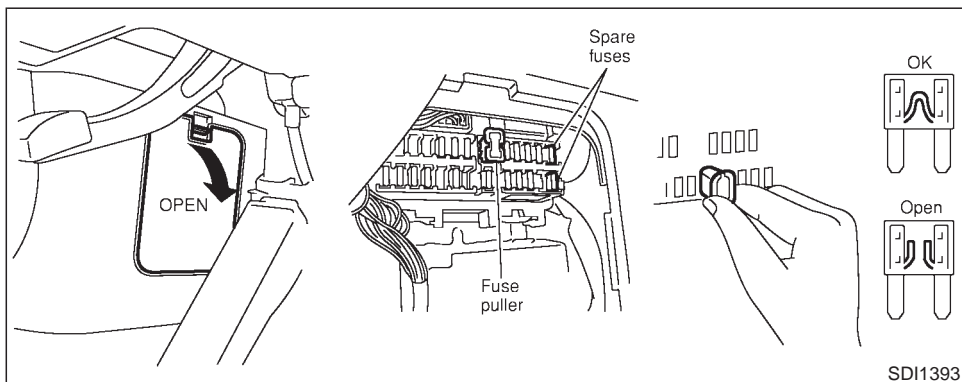

PASSENGER COMPARTMENT

INFINITI dealer.

If any electrical equipment does not operate, check for an open fuse.

1. Be sure the ignition key and the headlight switch are OFF.
2. Open the fuse box lid.
3. Pinch the fuse perpendicularly with the fuse puller and pull it out.
4. If the fuse is open, replace it with a new fuse.
5. If a new fuse also opens, have the electrical system checked and repaired by your

KEYFOB BATTERY REPLACEMENT

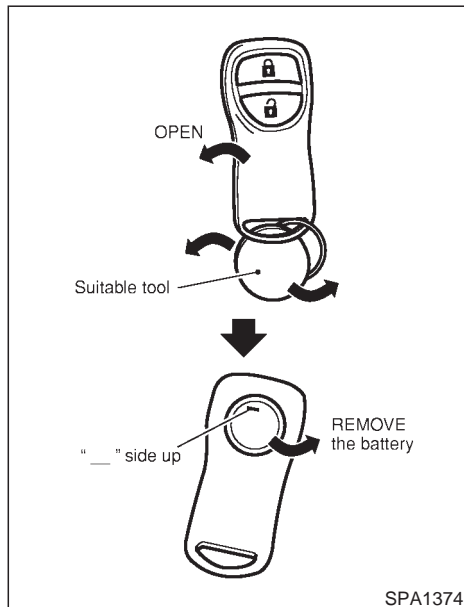

Replace the battery as follows:

1. Open the lid using a suitable tool.
2. Replace the battery with a new one.
Recommended battery: CR2025 or equivalent

Make sure that the ⊕ side faces the bottom case.

3. Close the lid securely.
4. Push the keyfob button two or three times to check its operation.

See your INFINITI dealer if you need any assistance for replacement.

If the battery is removed for any reason other than replacement, perform step 4 above.

- Be careful not to touch the circuit board and the battery terminal.
- An improperly disposed battery can harm the environment. Always confirm local regulations for battery disposal.
- The keyfob is water-resistant; however, if it gets wet, immediately wipe it completely dry.
- When changing batteries, do not let dust or oil get on the keyfob.

FCC Notice:

Changes or modifications not expressly approved by the manufacturer compliance could void the user's authority to operate the equipment. This device complies with Part 15 of the FCC Rules and RSS-210 of

Industry Canada. Operation is subject to the following two conditions: (1) This device may not cause harmful interference, and (2) this device must accept any interference received, including interference that may cause undesired operation of the device.

LIGHTS

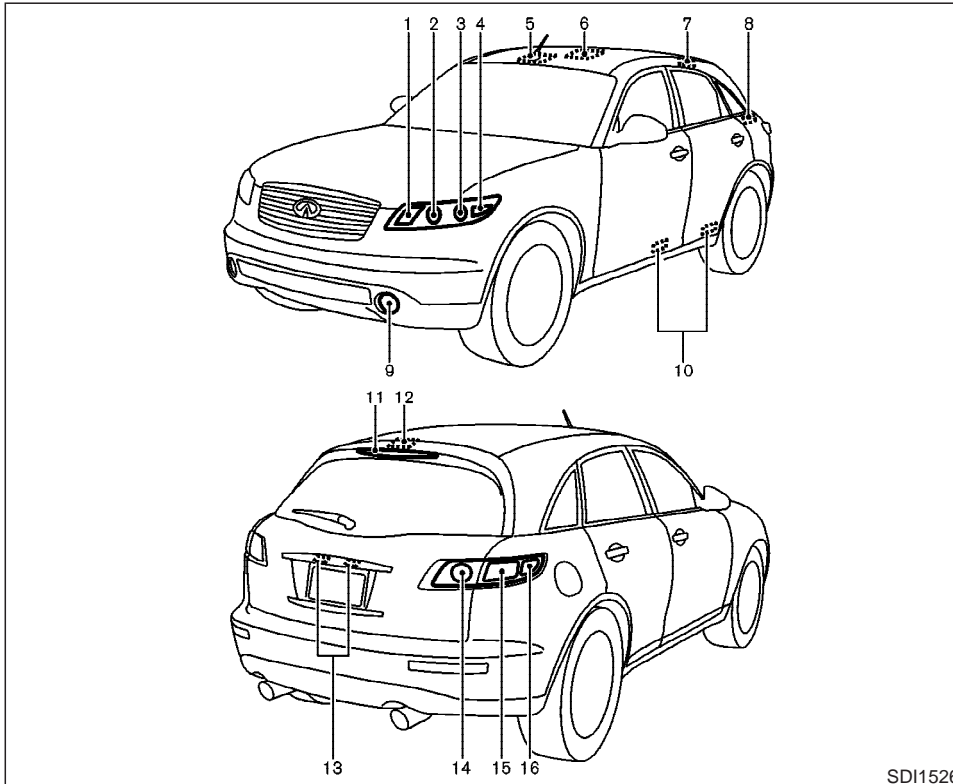

1. Clearance light/Daytime running light (Canada)
2. Headlight (low-beam, high-beam)
3. Front turn signal light
4. Front side marker light
5. Interior light/Map light
6. Ceiling light (if so equipped)
7. Rear personal light
8. Luggage light (side)
9. Front fog light
10. Step light
11. High-mounted stop light
12. Luggage light (roof)
13. License plate light
14. Back-up light
15. Tail/Stop/Turning signal lights
16. Rear side marker light

SDI1526

HEADLIGHTS

Replacing

If replacement is required, see an INFINITI dealer.

Xenon headlight bulb:



WARNING



HIGH VOLTAGE

When xenon headlights are on, they produce a high voltage. To prevent an electric shock, never attempt to modify or disassemble the headlight assembly. Always have your xenon headlights replaced at an INFINITI dealer. For additional information, see “Headlight and turn signal switch” in the “2. Instruments and controls” section.

EXTERIOR AND INTERIOR LIGHTS

Item	Wattage (W)	Bulb No.
Front turn signal	21	T20
Clearance/Daytime running light	5/21	T20
Front side marker light	3.8	T10
Front fog light*	51	HB4
Rear combination light		
Tail/Stop/Turn signal lights*	(LED)	—
Side marker light	3.8	T10
Back-up light	18	T16
License plate light	5	T10
High-mounted stop light*	(LED)	—
Map light	8	—
Ceiling light (if so equipped)	8	—
Rear personal light	8	—
Step light*	5	—
Luggage (roof, side) light	8	—
Vanity mirror light (if so equipped)	1.32	—

*: See an INFINITI dealer for replacement.

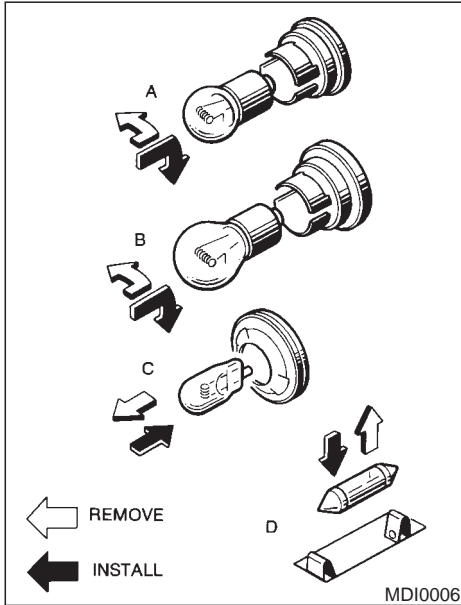

Replacement procedures

All other lights are either type A, B, C or D. When replacing a bulb, first remove the lens and/or cover.

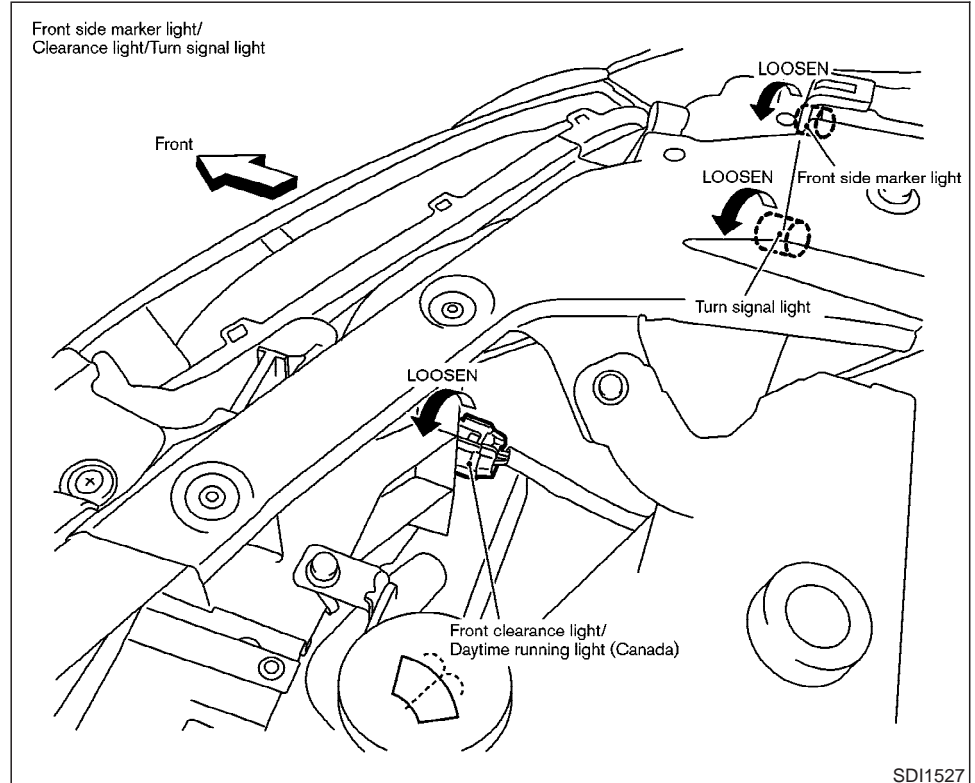

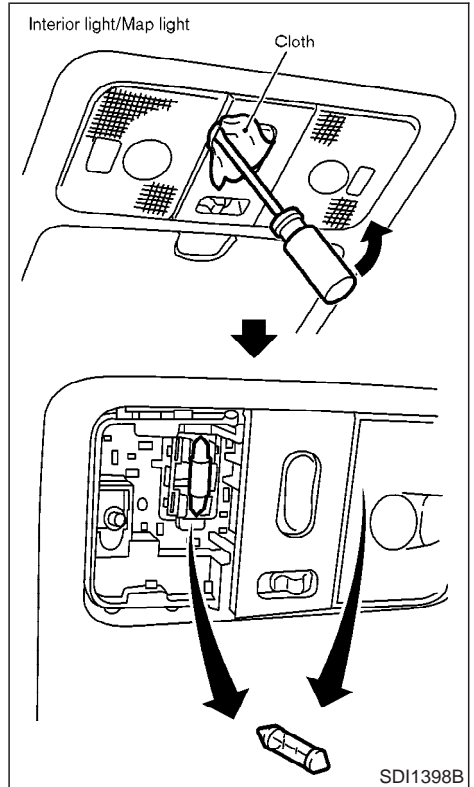
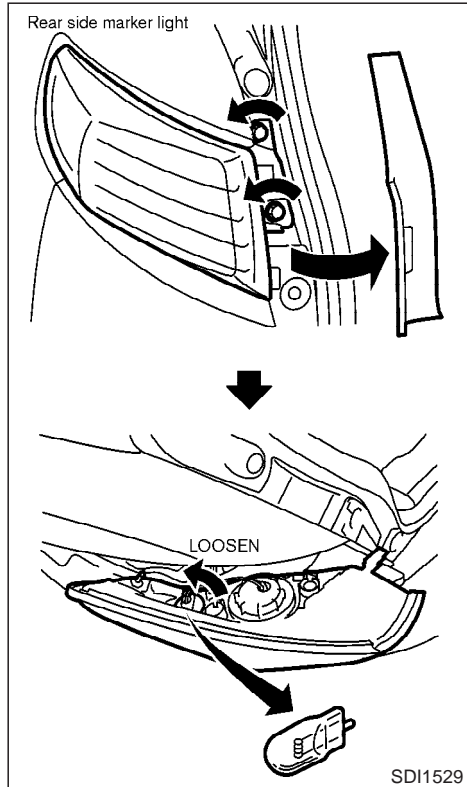
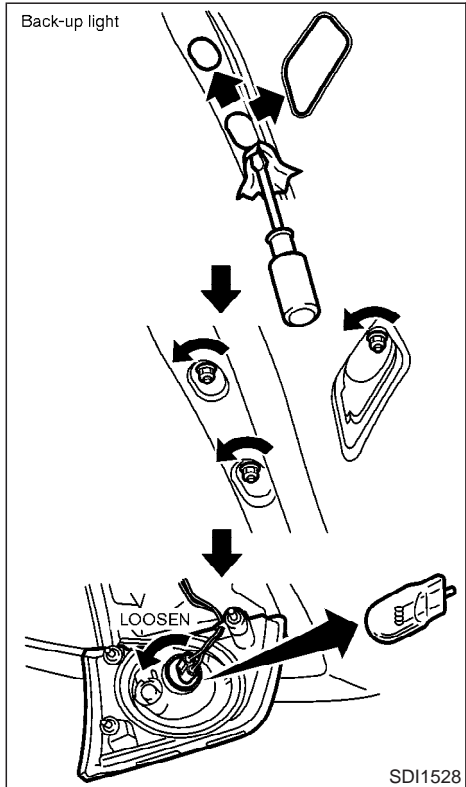

Rear personal light/Luggage (roof, side) light

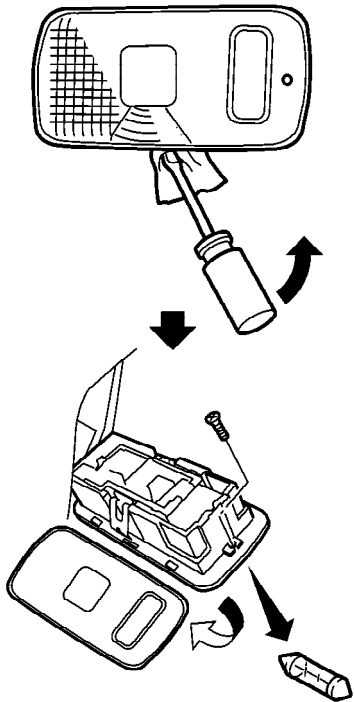

SDI1399B

Vanity mirror light

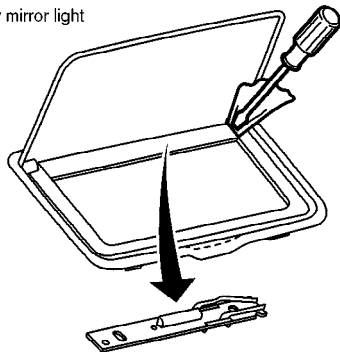

SDI1407A

Ceiling light

Cloth

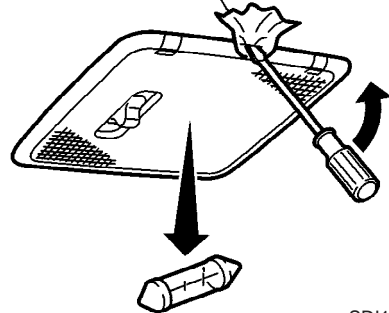

SDI1548

License plate light

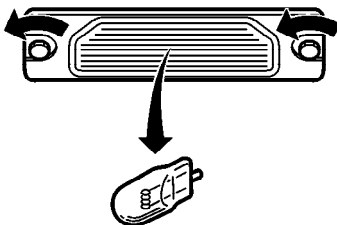

SDI1530

WHEELS AND TIRES

Tire inflation pressure

Check the tire pressure (including the spare) often and always prior to long distance trips. The recommended tire pressure specifications are shown on the Tire and Loading Information label under the “Recommended Cold Tire Inflation Pressure” heading. The Tire and Loading Information label is affixed to the driver side center pillar. Tire pressures should be checked regularly because:

- Most tires naturally lose air over time.
- Tires can lose air suddenly when driven over potholes or other objects or if the vehicle strikes a curb while parking.

The tire pressures should be checked when the tires are cold. The tires are considered COLD after the vehicle has been parked for 3 or more hours, or driven less than 1 mile (1.6 km) at moderate speeds.

Incorrect tire pressure, including underinflation, may adversely affect tire life and vehicle handling.

TIRE PRESSURE



WARNING

- **Improperly inflated tires can fail suddenly and cause an accident.**
- **The vehicle capacity weight is indicated on the Tire and Loading Information label. Do not load your vehicle beyond this capacity. Overloading your vehicle may result in reduced tire life, unsafe operating conditions due to premature tire failure, or unfavorable handling characteristics and could also lead to a serious accident. Loading beyond the specified capacity may also result in failure of other vehicle components.**
- **Before taking a long trip, or whenever you have loaded your vehicle heavily, use a tire pressure gauge to ensure that the tire pressure is at the specified level.**
- **Do not drive your vehicle over 85 MPH (140 km/h) unless it is equipped**

with high speed capability tires. Driving faster than 85 MPH (140 km/h) may result in tire failure, loss of control and possible injury.

- **For additional information regarding tires, refer to “Important Tire Safety Information” (US) or “Tire Safety Information” (Canada) in the INFINITI Warranty Information Booklet.**

Low tire pressure warning system

This vehicle is equipped with the low tire pressure warning system. It monitors tire pressure of all tires except the spare. When the low tire pressure warning light is lit, one or more of your tires is significantly under-inflated. The system also displays pressure of all tires (except the spare tire) on the display screen by sending a signal from a sensor that is installed in each wheel.

The low tire pressure warning system will activate only when the vehicle is driven at speeds above 20 MPH (32 km/h). Also, this system may not detect a sudden drop in tire pressure (for example a flat tire while driving).

For more details, refer to “Low tire pressure

warning light” in the “2. Instruments and controls” section, “Tire pressure information” in the “4. Display screen, heater, air conditioner and audio systems” section, “Low tire pressure warning system” in the “5. Starting and driving” section, and “Flat tire” in the “6. In case of emergency” section.

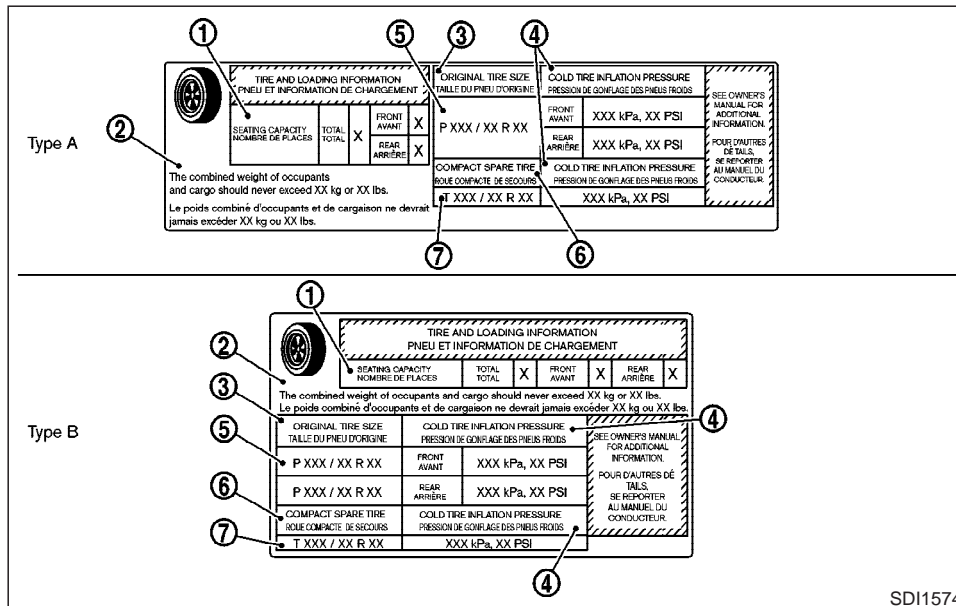

Tire and loading information label

① Seating capacity: The maximum number of occupants that can be seated in the vehicle.

② Vehicle load limit: See loading information in the Technical and consumer information section.

③ Original tire size: The size of the tires originally installed on the vehicle at the factory.

- ④ Recommended cold tire inflation pressure: Inflate the tires to this pressure when the tires are cold. Tires are considered COLD after the vehicle has been parked for 3 or more hours, or driven less than 1 mile (1.6 km) at moderate speeds. The recommended cold tire inflation is set by the manufacturer to provide the best balance of tire wear, vehicle handling driveability, tire noise, etc., up to the vehicle's GVWR.
- ⑤ Tire size — refer to "Tire labeling" later in this section.
- ⑥ and ⑦ Spare tire size or compact spare tire size (if so equipped)

Checking the tire pressure

1. Remove the valve stem cap from the tire.
2. Press the pressure gauge squarely onto the valve stem. Do not press too hard or force the valve stem sideways, or air will escape. If the hissing sound of air escaping from the tire is heard while checking the pressure, reposition the gauge to eliminate this leakage.
3. Remove the gauge.
4. Read the tire pressure on the gauge stem and compare it to the specification shown on the Tire and Loading Information label.

5. Add air to the tire as needed. If too much air is added, press the core of the valve stem briefly with the tip of the gauge stem to release pressure. Recheck the pressure and add or release air as needed.
6. Install the valve stem cap.
7. Check the pressure of all other tires, including the spare. (Refer to the "Wheels and tires" section)

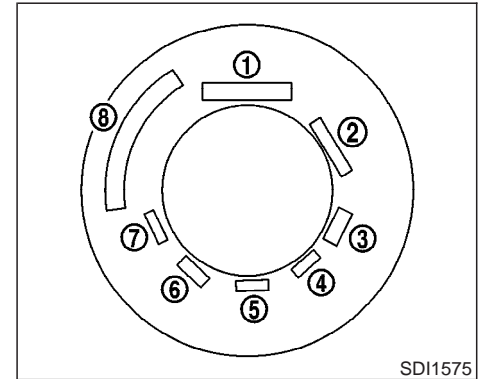

TIRE LABELING

Federal law requires tire manufacturers to place standardized information on the sidewall of all tires. This information identifies and describes the fundamental characteristics of the tire and also provides the tire identification number (TIN) for safety standard certification. The TIN can be used to identify the tire in case of a recall.

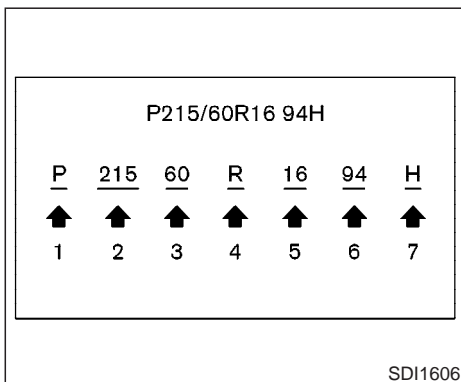

① Tire size (example: P215/60R16 94H)

1. P: The “P” indicates the tire is designed for passenger vehicles. (Not all tires have this information.)
2. Three-digit number (215): This number gives the width in millimeters of the tire from sidewall edge to sidewall edge.
3. Two-digit number (60): This number, known as the aspect ratio, gives the tire’s ratio of height to width.
4. R: The “R” stands for radial.

5. Two-digit number (16): This number is the wheel or rim diameter in inches.
6. Two- or three-digit number (94): This number is the tire’s load index. It is a measurement of how much weight each tire can support. You may not find this information on all tires because it is not required by law.
7. H: Speed Rating. The speed rating denotes the speed at which a tire is designed to be driven for extended periods of time. The ratings range from 98 miles per hour (MPH) to 186 MPH. (You may not find this information on all tires because it is not required by law.)

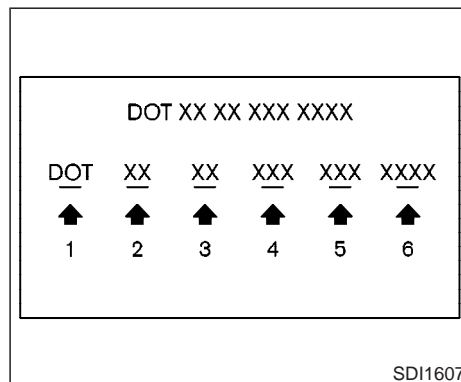

② TIN (Tire Identification Number) for new tire (example: DOT XX XX XXX XXXX)

1. DOT: Abbreviation for the “Department of Transportation”. The symbol can be placed above, below or to the left or right of the Tire Identification Number.
2. Two-digit code: Manufacturer’s identification mark
3. Two-digit code: Tire size
4. Three-digit code: Tire type code (Optional)

5. Four-digit code: Date of Manufacture
Four numbers represent the week and year the tire was built. For example, the numbers 3103 means the 31st week of 2003.

- ③ Tire ply composition and material
The number of layers or plies of rubber-coated fabric in the tire.
Tire manufacturers also must indicate the materials in the tire, which include steel, nylon, polyester, and others.

- ④ Maximum permissible inflation pressure
This number is the greatest amount of air pressure that should be put in the tire. Do not exceed the maximum permissible inflation pressure.

- ⑤ Maximum load rating
This number indicates the maximum load in kilograms and pounds that can be carried by the tire. When replacing the tires on the vehicle, always use a tire that has the same load rating as the factory installed tire.

- ⑥ Term of “tubeless” or “tube type”
Indicates that the tire requires an inner tube (“tube type”) or not (“tubeless”).

- ⑦ The word “radial”
The word “radial” is shown, if the tire has radial structure.

- ⑧ Manufacturer or Brand name
Manufacturer or Brand name is shown.

Other tire-related terminology

In addition to the many terms that are defined throughout this section, Intended Outboard Sidewall is (1) the sidewall that contains a whitewall, bears white lettering or bears manufacturer, brand and/or model name molding that is higher or deeper than the same molding on the other sidewall of the tire, or (2) the outward facing sidewall of an asymmetrical tire that has a particular side that must always face outward when mounted on a vehicle.

TYPES OF TIRES



WARNING

- **When changing or replacing tires, be sure all four tires are of the same type (i.e., summer, all season or snow) and construction. Your INFINITI dealer may be able to help you with information about tire type, size, speed rating and availability.**
- **Replacement tires may have a lower speed rating than the factory**

equipped tires, and may not match the potential maximum vehicle speed. Never exceed the maximum speed rating of the tire.

- **For additional information regarding tires, refer to “Important Tire Safety Information” (US) or “Tire Safety Information” (Canada) in the INFINITI Warranty Information Booklet.**

All season tires

INFINITI specifies all season tires on some models to provide good performance for use all year around, including snowy and icy road conditions. All season tires are identified by ALL SEASON and/or M&S on the tire sidewall. Snow tires have better snow traction than all season tires and may be more appropriate in some areas.

Summer tires

INFINITI specifies summer tires on some models to provide superior performance on dry roads. Summer tire performance is substantially reduced in snow and ice. Summer tires do not have the tire traction rating M&S (Mud and Snow) on the tire sidewall.

If you plan to operate your vehicle in snowy or icy conditions, INFINITI recommends the use of snow or all season tires on all four wheels.

Snow tires

If snow tires are needed, it is necessary to select tires equivalent in size and load rating to the original equipment tires. If you do not, it can adversely affect the safety and handling of your vehicle.

Generally, snow tires will have lower speed ratings than factory equipped tires and may not match the potential maximum vehicle speed. Never exceed the maximum speed rating of the tire.

If you operate your vehicle in snowy or icy conditions, INFINITI recommends the use of snow or all season tires on all four wheels.

For additional traction on icy roads, studded tires may be used. However, some provinces and states prohibit their use. Check local, state and provincial laws before installing studded tires. Skid and traction capabilities of studded snow tires, on wet or dry surfaces, may be poorer than that of non-studded snow tires.

All wheel drive models



CAUTION

- **Always use tires of the same size, brand, construction (bias, bias-belted or radial), and tread pattern on all four wheels. Failure to do so may result in a circumference difference between tires on the front and rear axles which will cause excessive tire wear and may damage the transmission, transfer case and differential gears.**
- **ONLY use spare tires specified for each 4-wheel drive model.**

If excessive tire wear is found, it is recommended that all four tires be replaced with tires of the same size, brand, construction and tread pattern. The tire pressure and wheel alignment should also be checked and corrected as necessary. Contact your INFINITI dealer.

Tire chains must be installed only on the rear wheels and not on the front wheels.

Do not drive with tire chains on paved roads which are clear of snow. Driving with chains in

such conditions can cause damage to the various mechanisms of the vehicle due to some overstress.

TIRE CHAINS

Use of tire chains may be prohibited according to location. Check the local laws before installing tire chains. When installing tire chains, make sure they are of proper size for the tires on your vehicle and are installed according to the chain manufacturer instructions. **Use only SAE class S chains.** Class “S” chains are used on vehicles with restricted tire to vehicle clearance. Vehicles that can use Class “S” chains are designed to meet the SAE standard minimum clearances between the tire and the closest vehicle suspension or body component required to accommodate the use of a winter traction device (tire chains or cables). The minimum clearances are determined using the factory equipped tire size. Other types may damage your vehicle. Use chain tensioners when recommended by the tire chain manufacturer to ensure a tight fit. Loose end links of the tire chain must be secured or removed to prevent the possibility of whipping action damage to the fenders or undercarriage. If possible, avoid fully loading your vehicle when using tire chains. In addition, drive at a reduced speed. Otherwise, your vehicle may be damaged and/or vehicle handling and performance may be adversely affected.

Tire chains must be installed only on the rear wheels and not on the front wheels.

Never install tire chains on a T-type spare tire (TEMPORARY USE ONLY). Do not use the chains on dry roads.

Driving with chains in such conditions can cause damage to the various mechanisms of the vehicle due to some overstress.

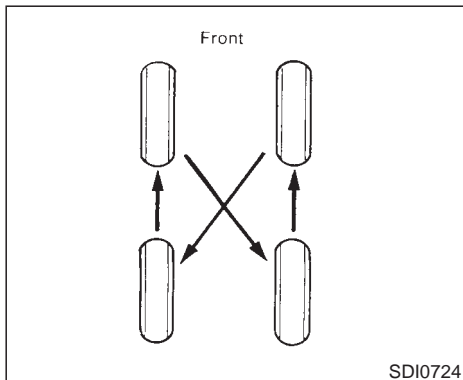

CHANGING WHEELS AND TIRES

Tire rotation

INFINITI recommends that tires be rotated every 7,500 miles (12,000 km).

**Wheel nut tightening torque:
80 ft-lb (108 N·m)**

See “Flat tire” in the “6. In case of emergency” section for tire replacing procedures.



WARNING

- After rotating the tires, adjust the tire pressure.
- Retighten the wheel nuts when the vehicle has been driven for 600 miles (1,000 km) (also in cases of a flat tire, etc.).
- Do not include the T-type spare tire or any other small size spare tire in the tire rotation.
- For additional information regarding tires, refer to “Important Tire Safety Information” (US) or “Tire Safety Information” (Canada) in the INFINITI Warranty Information Booklet.

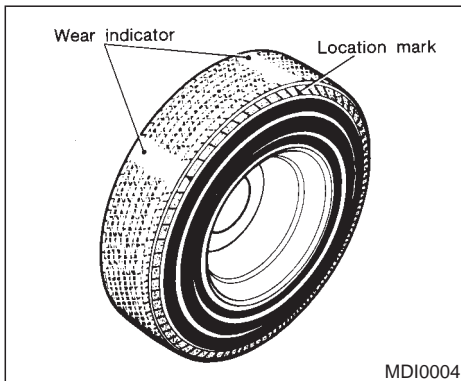

Tire wear and damage



WARNING

- Tires should be periodically inspected for wear, cracking, bulging, or objects caught in the tread. If excessive wear, cracks, bulging, or deep cuts are found, the tire should be replaced.
- The original tires have a built-in tread wear indicator. When the wear indica-

tor is visible, the tire should be replaced.

- Improper service for a spare tire may result in serious personal injury. If it is necessary to repair the spare tire, contact your INFINITI dealer.
- For additional information regarding tires, refer to “Important Tire Safety Information” (US) or “Tire Safety Information” (Canada) in the INFINITI Warranty Information Booklet.

Replacing wheels and tires

When replacing a tire, use the same size, speed rating and load carrying capacity as originally equipped. See “Specifications” in the “9. Technical and consumer information” section for recommended types and sizes of tires and wheels.



WARNING

- The use of tires other than those recommended or the mixed use of

tires of different brands, construction (bias, bias-belted or radial), or tread patterns can adversely affect the ride, braking, handling, ground clearance, body-to-tire clearance, tire chain clearance, speedometer calibration, headlight aim and bumper height. Some of these effects may lead to accidents and could result in serious personal injury.

- If the wheels are changed for any reason, always replace with wheels which have the same offset dimension. Wheels of a different offset could cause early tire wear, possibly degraded vehicle handling characteristics and/or interference with the brake discs. Such interference can lead to decreased braking efficiency and/or early brake pad wear.
- When a spare tire is mounted or a wheel is replaced, tire pressure will not be indicated and the low tire pressure warning system will not function. Contact your INFINITI dealer as

soon as possible for tire replacement and/or system resetting. (For models with the low tire pressure warning system)

- **Do not install a deformed wheel or tire even if it has been repaired. Such wheels or tires could have structural damage and could fail without warning.**
- **The use of retread tires is not recommended.**
- **For additional information regarding tires, refer to “Important Tire Safety Information” (US) or “Tire Safety Information” (Canada) in the Warranty Information Booklet.**

Wheel balance

Unbalanced wheels may affect vehicle handling and tire life. Even with regular use, wheels can get out of balance. Therefore, they should be balanced as required.

Wheel balance service should be performed with the wheels off the vehicle. Spin balancing

the rear wheels on the vehicle could lead to mechanical damage.

For additional information regarding tires, refer to “Important Tire Safety Information” (US) or “Tire Safety Information” (Canada) in the INFINITI Warranty Information Booklet.

Care of wheels

- Wash the wheels when washing the vehicle to maintain their appearance.
- Clean the inner side of the wheels when the wheel is changed or the underside of the vehicle is washed.
- Do not use abrasive cleaners when washing the wheels.
- Inspect wheel rims regularly for dents or corrosion. Such damage may cause loss of pressure or poor seal at the tire bead.
- INFINITI recommends that the side walls of road wheels be waxed to protect against road salt in areas where it is used during winter.

Spare tire (TEMPORARY USE ONLY spare tire (T-type))

Observe the following precautions if the T-type spare tire must be used, otherwise your ve-

hicle could be damaged or involved in an accident.



CAUTION

- **The T-type spare tire should be used only for emergency. It should be replaced by the standard tire at the first opportunity.**
- **Drive carefully while the T-type spare tire is installed.**
- **Avoid sharp turns and abrupt braking while driving.**
- **Periodically check the T-type spare tire inflation pressure, and always keep it at 60 psi (420 kPa, 4.2 bar).**
- **Always keep the pressure of the full size spare tire (if so equipped) at the recommended pressure for standard tires, as indicated on the Tire and Loading Information label. For the label location, see “Tire and Loading Information label” in the “9. Technical and consumer information”.**

- Do not drive your vehicle at speeds faster than 50 MPH (80 km/h).
- Do not use tire chains on a T-type spare tire. Tire chains will not fit properly on the T-type spare tire and may cause damage to the vehicle.
- When driving on roads covered with snow or ice, the T-type spare tire should be used on the front wheel and the original tire used on the rear wheels (drive wheels). Use tire chains only on the rear two original tires.
- Tire tread of the T-type spare tire will wear at a faster rate than the original tire. Replace the T-type spare tire as soon as the tread wear indicators appear.
- Because the T-type spare tire is smaller than the original tire, ground clearance is reduced. To avoid damage to the vehicle do not drive over obstacles. Also do not drive the vehicle through an automatic car wash since it may get caught.

- Do not use the T-type spare tire on other vehicles.
- Do not use more than one T-type spare tire at the same time.
- Do not tow a trailer while the T-type spare tire is installed.

MEMO

9 Technical and consumer information

Capacities and recommended fuel/lubricants	9-2	Air conditioner specification label.....	9-13
Fuel recommendation.....	9-3	Installing front license plate.....	9-14
Engine oil and oil filter recommendation.....	9-5	Vehicle loading information.....	9-15
Recommended SAE viscosity number.....	9-6	Terms	9-15
Air conditioning system refrigerant and lubricant recommendations	9-7	Vehicle load capacity	9-16
Specifications	9-8	Loading tips	9-16
Engine	9-8	Towing a trailer	9-17
Wheels and tires	9-10	Maximum load limits.....	9-17
Dimensions and weights	9-10	Towing load/specification chart	9-19
When traveling or registering your vehicle in another country.....	9-11	Towing safety	9-19
Vehicle identification	9-11	Flat towing	9-21
Vehicle identification number (VIN) plate.....	9-11	Uniform tire quality grading.....	9-22
Vehicle identification number (Chassis number)	9-11	Emission control system warranty	9-23
Engine serial number	9-12	Reporting safety defects (US only).....	9-23
F.M.V.S.S. certification label	9-12	Readiness for inspection/maintenance (I/M) test (US only)	9-24
Emission control information label	9-13	Event Data Recorders.....	9-25
Tire placard	9-13	Owner's Manual/Service Manual order information.....	9-25
		In the event of a collision	9-25

CAPACITIES AND RECOMMENDED FUEL/LUBRICANTS

The following are approximate capacities. The actual refill capacities may be a little different. When refilling, follow the procedure instructed in the “8. Maintenance and do-it-yourself” section to determine the proper refill capacity.

	Capacity (Approximate)			Recommended specifications
	US measure	Imp measure	Liter	
Fuel	23-3/4 gal	19-3/4 gal	90	Unleaded gasoline with an octane rating of at least 91 AKI (RON 96)*1
Engine oil*6 Drain and refill				
With oil filter change	VK45DE	6-3/4 qt	5-5/8 qt	6.4 For VK45DE engine • API Certification Mark*2, *3 • API grade SJ or SL, Energy Conserving*2, *3 • ILSAC grade GF-II & GF-III*2, *3
	VQ35DE	5 qt	4-1/8 qt	
Without oil filter change	VK45DE	6-1/8 qt	5-1/8 qt	5.8 For VQ35DE engine • API Certification Mark*2, *3 • API grade SG/SH, Energy Conserving I & II or API grade SJ or SL, Energy Conserving*3 • ILSAC grade GF-I, GF-II & GF-III*3
	VQ35DE	4-5/8 qt	3-7/8 qt	
Cooling system				
With reservoir	VK45DE	10-5/8 qt	8-3/4 qt	10.0 Genuine NISSAN Long Life Antifreeze/Coolant or equivalent
	VQ35DE	9-1/8 qt	7-5/8 qt	
Reservoir	VK45DE	7/8 qt	3/4 qt	0.8
	VQ35DE	7/8 qt	3/4 qt	
Automatic transmission fluid	—	—	—	Genuine Nissan Matic J ATF*4
Differential gear oil	—	—	—	API GL-5 Viscosity SAE 80W-90*7
Transfer fluid	—	—	—	Genuine Nissan Matic D ATF (Continental U.S. and Alaska) or Canada NISSAN Automatic Transmission Fluid*8
Power steering fluid (PSF)	Refill to the proper oil level according to the instructions in the “8. Maintenance and do-it-yourself” section.	—	—	Genuine NISSAN PSF or equivalent*10
Brake fluid	—	—	—	Genuine NISSAN Super Heavy Duty Brake Fluid*5 or equivalent DOT 3 (U.S. FMVSS No. 116)
Multi-purpose grease	—	—	—	NLGI No. 2 (Lithium soap base)
Air conditioning system refrigerant	—	—	—	HFC-134a (R-134a)*9
Air conditioning system lubricants	—	—	—	Nissan A/C System Oil Type S or exact equivalent
Windshield washer fluid	—	—	—	Genuine NISSAN Windshield Washer Concentrate Cleaner & Antifreeze or equivalent

*1: For additional information, see later in this paragraph for fuel recommendation.

*2: For additional information, see later in this paragraph for engine oil and oil filter recommendation.

*3: For additional information, see later in this paragraph for recommended SAE viscosity number.

*4: **Using automatic transmission fluid other than Genuine Nissan Matic J ATF will cause deterioration in driveability and automatic transmission durability, and may damage the automatic transmission, which is not covered by the INFINITI new vehicle limited warranty.**

*5: Available in mainland US through your INFINITI dealer.

*6: For additional information, see “Engine oil” in the “8. Maintenance and do-it-yourself” section for changing engine oil.

*7: For hot climates, viscosity SAE 90 is suitable for ambient temperatures above 0°C (32°F).

*8: DEXRONTMIII/MERCONTM or equivalent may also be used. Outside the continental United States and Alaska contact an INFINITI dealer for more information regarding suitable fluids, including recommended brand(s) of DEXRONTMIII/MERCONTM automatic transmission fluid.

*9: For additional information, see “Vehicle identification” in this section for air conditioner specification label.

*10: For Canada, Nissan Automatic Transmission Fluid (ATF), DEXRONTMIII/MERCONTM or equivalent ATF may also be used.

9-2 Technical and consumer information

FUEL RECOMMENDATION

VK45DE engine

In order to maintain engine and exhaust system durability and performance, unleaded premium gasoline with an octane rating of at least 91 AKI (Anti-Knock Index) number (Research octane number 96) must be used.

If premium gasoline is not available, unleaded regular gasoline with an octane rating of 87 AKI number (Research octane number 91) may be temporarily used, but only under the following precautions:

- Have the fuel tank filled only partially with unleaded regular gasoline, and fill up with unleaded premium gasoline as soon as possible.
- Avoid full throttle driving and abrupt acceleration

VQ35DE engine

Use unleaded regular gasoline with an octane rating of at least 87 AKI (Anti-Knock Index) number (Research octane number 91).

For improved vehicle performance, INFINITI recommends the use of unleaded premium gasoline with an octane rating of at least 91 AKI number (Research octane number 96).



CAUTION

Using a fuel other than that specified could adversely affect the emission control devices and systems, and could also affect the warranty coverage.

Under no circumstances should a leaded gasoline be used, since this will damage the three-way catalyst.

Reformulated gasoline

Some fuel suppliers are now producing reformulated gasolines. These gasolines are specially designed to reduce vehicle emissions. INFINITI supports efforts towards cleaner air and suggests that you use reformulated gasoline when available.

Gasoline containing oxygenates

Some fuel suppliers sell gasoline containing oxygenates such as ethanol, MTBE and methanol with or without advertising their presence. INFINITI does not recommend the use of fuels of which the oxygenate content and the fuel compatibility for your INFINITI cannot be readily determined. If in doubt, ask your service station manager.

If you use oxygenate-blend gasoline, please take the following precautions as the usage of such fuels may cause vehicle performance problems and/or fuel system damage.

- **The fuel should be unleaded and have an octane rating no lower than that recommended for unleaded gasoline.**
- **If an oxygenate-blend, excepting a methanol blend, is used, it should contain no more than 10% oxygenate. (MTBE may, however, be added up to 15%).**
- **If a methanol blend is used, it should contain no more than 5% methanol (methyl alcohol, wood alcohol). It should also contain a suitable amount of appropriate cosolvents and corrosion inhibitors. If not properly formulated with appropriate cosolvents and corrosion inhibitors, such methanol blends may cause fuel system damage and/or vehicle performance problems. At this time, sufficient data is not available to ensure that all methanol blends are suitable for use in INFINITI vehicles.**

If any undesirable driveability problems such as engine stalling and hard hot starting are experienced after using oxygenate-blend fuels, immediately change to a non-oxygenate

fuel or a fuel with a low blend of MTBE.

Take care not to spill gasoline during refueling. Gasoline containing oxygenates can cause paint damage.

Aftermarket fuel additives

INFINITI does not recommend the use of any fuel additives (i.e. fuel injector cleaner, octane booster, intake valve deposit removers, etc.) which are sold commercially. Many of these additives intended for gum, varnish or deposit removal may contain active solvent or similar ingredients that can be harmful to the fuel system and engine.

Octane rating tips

In most parts of North America, you should use unleaded gasoline with an octane rating of at least 87 or 91 AKI (Anti-Knock Index) number. However, you may use unleaded gasoline with an octane rating as low as 85 AKI number in these high altitude areas [over 4,000 ft (1,219 m)] such as: Colorado, Montana, New Mexico, Utah, Wyoming, northeastern Nevada, southern Idaho, western South Dakota, western Nebraska, and that part of Texas which is directly south of New Mexico.

Using unleaded gasoline with an octane rating lower than stated above can cause

persistent, heavy spark knock. (Spark knock is a metallic rapping noise.) If severe, this can lead to engine damage. If you detect a persistent heavy spark knock even when using gasoline of the stated octane rating, or if you hear steady spark knock while holding a steady speed on level roads, have your dealer correct the condition. Failure to correct the condition is misuse of the vehicle, for which INFINITI is not responsible.

Incorrect ignition timing will result in knocking, after-run or overheating. This in turn may cause excessive fuel consumption or damage to the engine. If any of the above symptoms are encountered, have your vehicle checked at an INFINITI dealer or other competent service facility.

However, now and then you may notice light spark knock for a short time while accelerating or driving up hills. This is no cause for concern, because you get the greatest fuel benefit when there is light spark knock for a short time under heavy engine load.

API certification mark



API service symbol

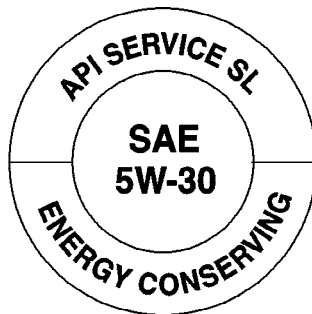

STI0367

ENGINE OIL AND OIL FILTER RECOMMENDATION

Selecting the correct oil

It is essential to choose the correct quality, and viscosity oil to ensure satisfactory engine life and performance. INFINITI recommends the use of a low friction oil (energy conserving oil) in order to improve fuel economy and conserve energy. Oils which do not have the specified quality label should not be used as they could cause engine damage.

Only those engine oils with the American Petroleum Institute (API) certification mark on the

front of the container should be used. This type of oil supersedes the existing API SG, SH, or SJ and Energy Conserving I & II categories.

If you cannot find engine oil with the API certification mark, use an API grade SJ or SL, Energy conserving oil. An ILSAC grade GF-II & GF-III oil can also be used.

INFINITI recommends mineral based oils. These oils must however, meet the API quality and SAE viscosity ratings specified for your vehicle.

Oil additives

INFINITI does not recommend the use of oil additives. The use of an oil additive is not necessary when the proper oil type is used and maintenance intervals are followed.

Oil which may contain foreign matter or has been previously used should not be used.

Oil viscosity

The engine oil viscosity or thickness changes with temperature. Because of this, it is important that the engine oil viscosity be selected based on the temperatures at which the vehicle will be operated before the next oil change. The recommended SAE viscosity number chart shows the recommended oil viscosities for the expected ambient temperatures. Choosing an oil viscosity other than that recommended could cause serious engine damage.

Selecting the correct oil filter

Your new vehicle is equipped with a high-quality genuine NISSAN oil filter. When replacing, use the genuine oil filter or its equivalent for the reason described in change intervals.

Change intervals

The oil and oil filter change intervals for your

Technical and consumer information 9-5

engine are based on the use of the specified quality oils and filters. Oil and filter other than the specified quality, or oil and filter change intervals longer than recommended could reduce engine life. Damage to engines caused by improper maintenance or use of incorrect oil and filter quality and/or viscosity is not covered by the new INFINITI vehicle warranties.

Your engine was filled with a high quality engine oil when it was built. You do not have to change the oil before the first recommended change interval. Oil and filter change intervals depend upon how you use your vehicle. Operation under the following conditions may require more frequent oil and filter changes.

- repeated short distance driving at cold outside temperatures,
- driving in dusty conditions,
- extensive idling,
- towing a trailer.
- Operating in hot weather in stop-and-go rush hour traffic.

RECOMMENDED SAE VISCOSITY NUMBER

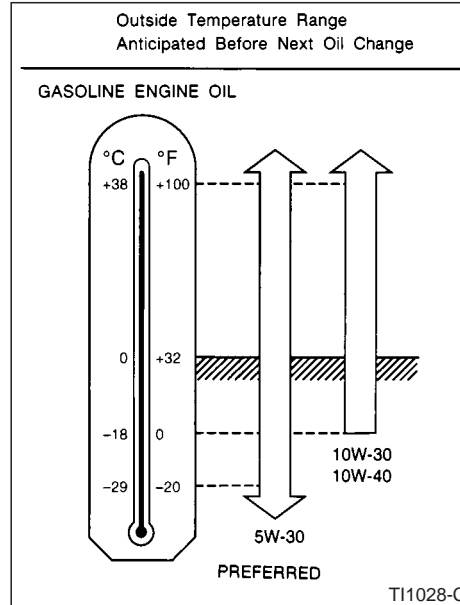

5W-30 will positively improve fuel economy.

SAE 5W-30 viscosity oil is preferred for all ambient temperatures. SAE 10W-30, 10W-40 viscosity oil may be used if the ambient temperature is above 0°F (-18°C).

AIR CONDITIONING SYSTEM REFRIGERANT AND LUBRICANT RECOMMENDATIONS

The air conditioning system in this INFINITI vehicle must be charged with the refrigerant HFC-134a (R-134a) and the lubricant, Nissan A/C System Oil Type S or the exact equivalents.



CAUTION

The use of any other refrigerant or lubricant will cause severe damage to the air conditioning system and will require the replacement of all air conditioner system components.

The refrigerant HFC-134a (R-134a) in your INFINITI vehicle will not harm the earth's ozone layer. Although this refrigerant does not affect the earth's atmosphere, certain governmental regulations require the recovery and recycling of any refrigerant during automotive air conditioning system service. Your INFINITI dealer has the trained technicians and equipment needed to recover and recycle your air conditioning system refrigerant.

Contact your INFINITI dealer when servicing your air conditioning system.

SPECIFICATIONS

ENGINE

Model		VQ35DE	VK45DE
Type		Gasoline, 4-cycle	Gasoline, 4-cycle
Cylinder arrangement		6-cylinder, V-slanted at 60°	8-cylinder, V-slanted at 90°
Bore × Stroke	in (mm)	3.760 × 3.205 (95.5 × 81.4)	3.661 × 3.256 (93.0 × 82.7)
Displacement	cu in (cm ³)	213.45 (3,498)	274.2 (4,494)
Firing order		1-2-3-4-5-6*	1-8-7-3-6-5-4-2*1
Idle speed	rpm	See the emission control information label on the under- side of the hood.	See the emission control label on the underside of the hood.
Ignition timing (B.T.D.C.)	degree/rpm		
CO percentage at idle speed	[No air] %		
Spark plug	Standard	PLFR5A-11	PLFR5A-11
	Service option	Hot type	PLFR4A-11
		Cold type	PLFR6A-11
Spark plug gap (Normal)	in (mm)	0.043 (1.1)	0.043 (1.1)
Camshaft operation		Timing chain	Timing chain

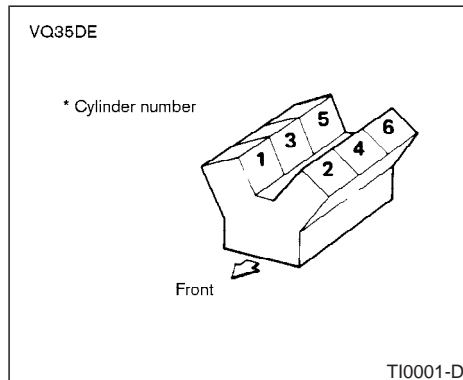

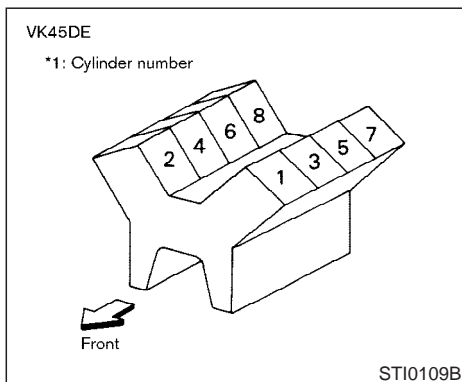

The spark ignition system of this vehicle meets all requirements of the Canadian Interference-Causing Equipment Regulations.

WHEELS AND TIRES

Road wheel

Type	Size	Offset	in (mm)
Aluminum	18 x 8JJ 20 x 8JJ	1.57	(40)

*: Option for Canada

Tire

Type	Size	Pressure (Cold)
Conventional	P265/60R18	220 kPa, 32 psi
	P265/50R20	
Spare	T175/90D18	420 kPa, 60 psi
	Conventional	—

DIMENSIONS AND WEIGHTS

MPV		
Overall length	in (mm)	189.1 (4,803)
Overall width	in (mm)	75.8 (1,925)
Overall height	in (mm)	65.0 (1,652)
		65.9 (1,672.6)*
Front tread	in (mm)	62.7 (1,592)
Rear tread	in (mm)	64.6 (1,642)
Wheelbase	in (mm)	112.2 (2,850)
Gross vehicle weight rating	See the F.M.V.S.S. certification label on the driver's side lock pillar.	
Gross axle weight rating	See the F.M.V.S.S. certification label on the driver's side lock pillar.	

*: Roof rail equipped models

WHEN TRAVELING OR REGISTERING YOUR VEHICLE IN ANOTHER COUNTRY

When planning to travel in another country, you should first find out if the fuel available is suitable for your vehicle's engine.

Using fuel with too low an octane rating may cause engine damage. All gasoline vehicles must be operated with unleaded engine gasoline. Therefore, avoid taking your vehicle to areas where appropriate fuel is not available.

When transferring the registration of your vehicle to another country, state, province or district, it may be necessary to modify the vehicle to meet local laws and regulations.

The laws and regulations for motor vehicle emission control and safety standards vary according to the country, state, province or district; therefore, vehicle specifications may differ.

When any vehicle is to be taken into another country, state, province or district and registered, its modifications, transportation, and registration are the responsibility of the user. INFINITI is not responsible for any inconvenience that may result.

VEHICLE IDENTIFICATION

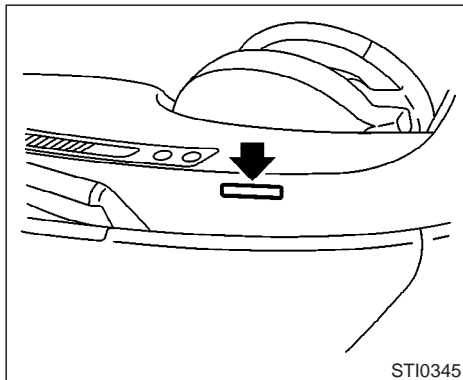

VEHICLE IDENTIFICATION NUMBER (VIN) PLATE

The vehicle identification number plate is attached as shown. This number is the identification for your vehicle and is used in the vehicle registration.

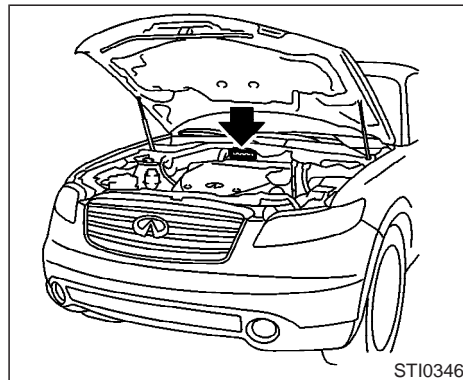

VEHICLE IDENTIFICATION NUMBER (Chassis number)

The number is stamped as shown.

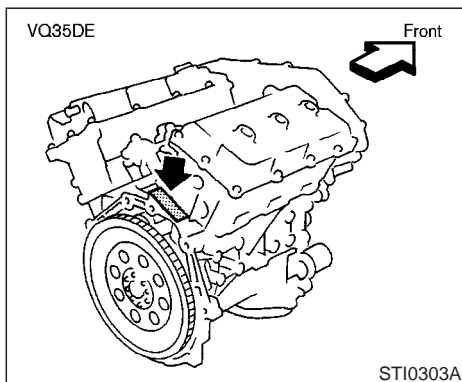

ENGINE SERIAL NUMBER

The number is stamped on the engine as shown.

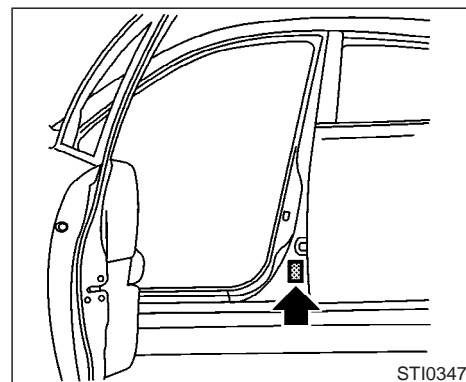
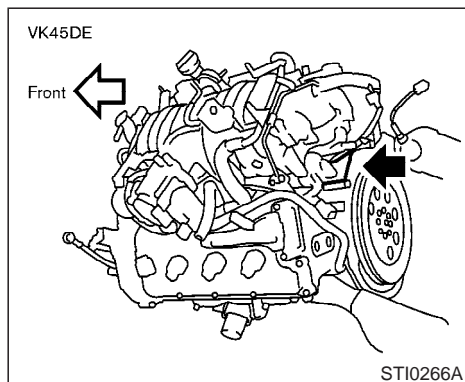

F.M.V.S.S. CERTIFICATION LABEL

The Federal Motor Vehicle Safety Standards (F.M.V.S.S.) certification label is affixed as shown. This label contains valuable vehicle information, such as: Gross Vehicle Weight Ratings (GVWR), Gross Axle Weight Rating (GAWR), month and year of manufacture, Vehicle Identification Number, (VIN), etc. Review it carefully.

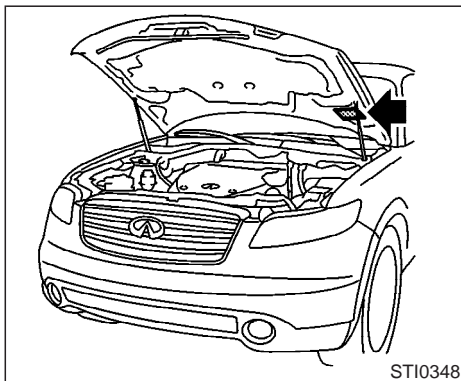

EMISSION CONTROL INFORMATION LABEL

The emission control information label is attached as shown.

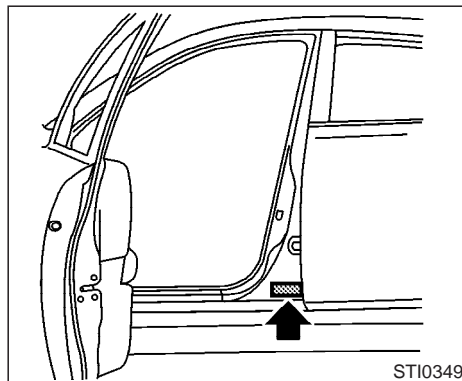

TIRE AND LOADING INFORMATION LABEL

The cold tire pressure is shown on the tire placard affixed as shown.

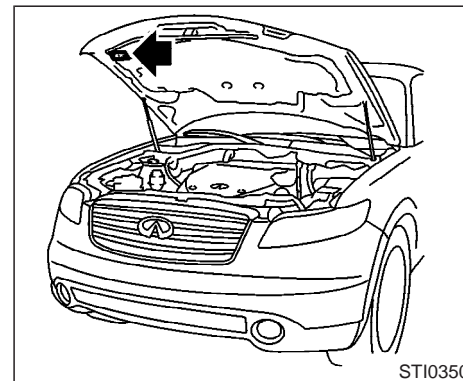

AIR CONDITIONER SPECIFICATION LABEL

The air conditioner specification label is affixed inside of the hood as shown.

INSTALLING FRONT LICENSE PLATE

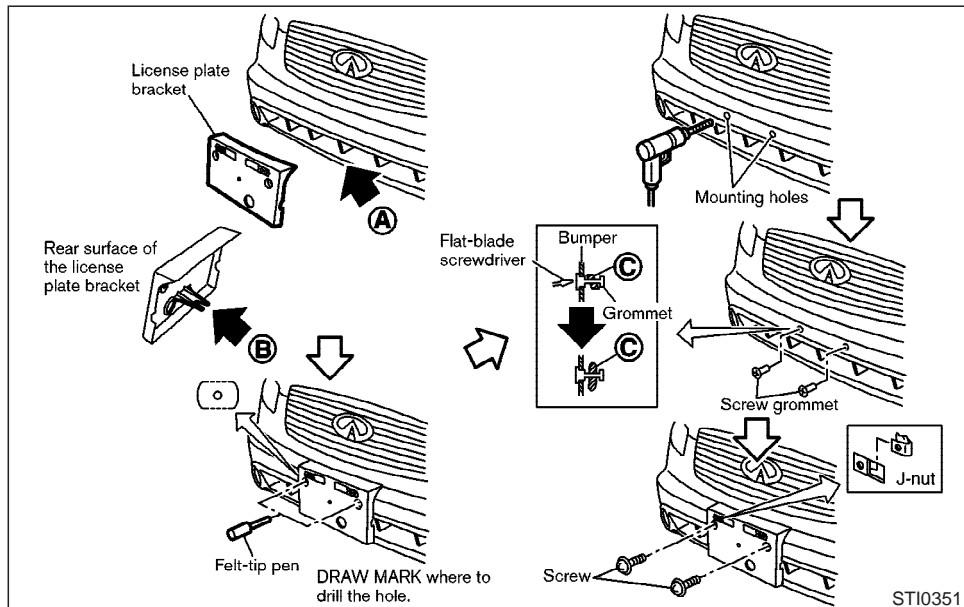

Use the following steps to mount the license plate:

Before mounting the license plate, confirm that the following parts are enclosed in the vinyl bag.

- License plate bracket
- J-nut x 2
- Screw x 2
- Screw grommet x 2

1. Temporarily place the license plate bracket while aligning part (A) of the front bumper with part (B) of the rear surface of the license plate bracket.
2. To determine where to drill the hole, mark along both sides of the mounting hole by using a felt-tip pen.
3. Remove the license plate bracket and connect the arcs to form ovals. Mark the point in the center of each oval. These are the pilot drilling locations.
4. Carefully drill two pilot holes using a 0.39 inch (10 mm) drill bit at the marked locations. **(Be sure that the drill only goes through the fascia, or damage to the nut may occur.)**
5. Insert grommets into the hole on the fascia.
6. Insert a flat-blade screwdriver into the grommet hole to add 90° turn onto the part (C).
7. Insert a J-nut into the license plate bracket before placing the license plate bracket on the fascia.
8. Install the license plate bracket with screws.
9. Install the license plate with bolts that are no longer than 0.55 inch (14 mm).

VEHICLE LOADING INFORMATION



WARNING

- **It is extremely dangerous to ride in a cargo area inside of a vehicle. In a collision, people riding in these areas are more likely to be seriously injured or killed**
- **Do not allow people to ride in any area of your vehicle that is not equipped with seats and seat belts.**
- **Be sure everyone in your vehicle is in a seat and using a seat belt properly.**

TERMS

It is important to familiarize yourself with the following terms before loading your vehicle:

- **Curb Weight** (actual weight of your vehicle) - vehicle weight including: standard and optional equipment, fluids, emergency tools, and spare tire assembly. This weight **does not** include passengers and cargo.
- **GVW** (Gross Vehicle Weight) - curb weight plus the combined weight of passengers and cargo.
- **GVWR** (Gross Vehicle Weight Rating) - maximum total combined weight of the unloaded vehicle, passengers, luggage, hitch, trailer tongue load and any other optional equipment. This information is located on the F.M.V.S.S. label.
- **GAWR** (Gross Axle Weight Rating) - maximum weight (load) limit specified for the front or rear axle. This information is located on the F.M.V.S.S. label.
- **GCWR** (Gross Combined Weight Rating) - The maximum total weight rating of the vehicle, passengers, cargo, and trailer.
- **Vehicle Capacity Weight, Load limit, Total load capacity** - maximum total weight limit specified of the load (passengers and cargo) for the vehicle. This is the maximum combined weight of occupants and cargo that can be loaded into the vehicle. If the vehicle is used to tow a trailer, the trailer tongue weight must be included as part of the cargo load. This information is located on the Tire and Loading Information label.
- **Cargo capacity** - permissible weight of cargo, the subtracted weight of occupants from the load limit.

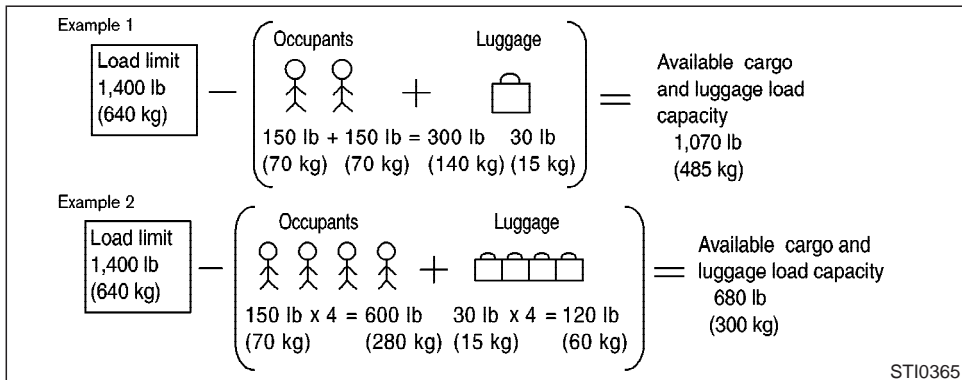

VEHICLE LOAD CAPACITY

Do not exceed the load limit of your vehicle shown as “The combined weight of occupants and cargo” on the Tire and Loading Information label. Do not exceed the number of occupants shown as “Seating Capacity” on the Tire and Loading Information label.

To get “the combined weight of occupants and cargo”, add the weight of all occupants, then add the total luggage weight to the value. Examples are shown in the illustration.

Steps for determining correct load limit

- (1) Locate the statement “The combined weight of occupants and cargo should never exceed XXX kilograms or XXX pounds” on your vehicle’s placard.
- (2) Determine the combined weight of the driver and passengers that will be riding in your vehicle.
- (3) Subtract the combined weight of the driver and passengers from XXX kilograms or XXX pounds.

(4) The resulting figure equals the available amount of cargo and luggage load capacity. For example, if the “XXX” amount equals 1,400 lbs. and there will be five 150 lb. passengers in your vehicle, the amount of available cargo and luggage load capacity is 650 lbs. [1,400 – 750 (5 x 150) = 650 lbs.]

(5) Determine the combined weight of luggage and cargo being loaded on the vehicle. For safety, that weight must not exceed the available cargo and luggage load capacity calculated in Step 4.

(6) If your vehicle will be towing a trailer, load from your trailer will be transferred to your vehicle. Consult this manual to determine how this reduces the available cargo and luggage load capacity of your vehicle.

LOADING TIPS

- The GVW must not exceed GVWR or GAWR as specified on the F.M.V.S.S. certification label.
- Do not load the front and rear axle to the GAWR. Doing so will exceed the GVWR.



WARNING

- Properly secure all cargo to help prevent it from sliding or shifting. Do not place cargo higher than the seat-backs. In a sudden stop or collision, unsecured cargo could cause personal injury.
- Do not load your vehicle any heavier than the GVWR or the maximum front and rear GAWRs. If you do, parts on your vehicle can break, or it can change the way your vehicle handles. This could result in loss of control and cause personal injury.
- Overloading not only could shorten the life of your vehicle and the tires, but also could lead to hazardous vehicle handling and long braking distance. This may cause a premature tire malfunction, which could result in a serious accident and personal injury. Failures caused by overloading are not covered by your warranty.

TOWING A TRAILER

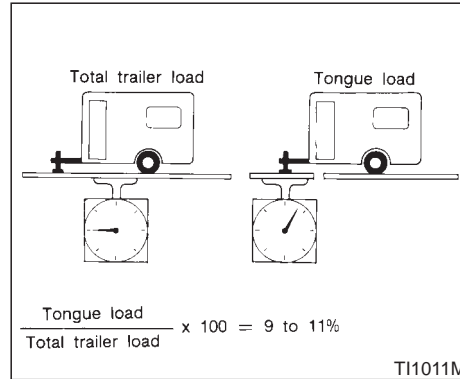

Your new vehicle was designed to be used primarily to carry passengers and cargo. Remember that towing a trailer will place additional loads on your vehicle's engine, drive train, steering, braking and other systems.

Information on trailer towing ability and the special equipment required should be obtained from your INFINITI dealer. He can obtain an **INFINITI Trailer Towing Guide** for you.

MAXIMUM LOAD LIMITS

Maximum trailer loads

Never allow the total trailer load to exceed the value specified in the following Towing Load/Specification Chart. The total trailer load equals trailer weight plus its cargo weight.

- When towing a trailer load of 1,000 lbs. (454 kg) or more, trailers with a brake system **MUST** be used.

The maximum GCWR (Gross Combined Weight Rating) should not exceed the value specified in the following Towing Load/Specification Chart.

The GCWR equals the combined weight of the towing vehicle (including passengers and cargo) plus the total trailer load. Towing loads greater than these or using improper towing equipment could adversely affect vehicle handling, braking and performance.

The ability of your vehicle to tow a trailer is not only related to the maximum trailer loads, but also the places you plan to tow. Tow weights appropriate for level highway driving may have to be reduced on very steep grades or in low traction situations (for example, on slippery boat ramps).



CAUTION

Vehicle damage resulting from improper towing procedures are not covered by INFINITI warranties. An INFINITI Trailer Towing Guide (U.S. only) containing information on trailer towing ability and the special equipment required may be obtained from an INFINITI dealer.

Tongue load

Keep the tongue load between 9 to 11% of the total trailer load within the maximum tongue load limits shown in the following Towing Load/Specifications Chart. If the tongue load becomes excessive, rearrange cargo to allow for proper tongue load.

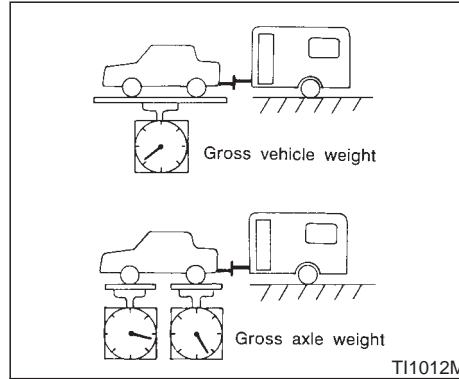

Maximum gross vehicle weight/ maximum gross axle weight

The gross vehicle weight of the towing vehicle must not exceed. GVWR shown on the F.M.V.S.S. certification label. The gross vehicle weight equals the combined weight of the unloaded vehicle, passengers, luggage, hitch, trailer tongue load and any other optional equipment. In addition, front or rear gross axle weight must not exceed GAWR shown on the F.M.V.S.S. certification label.

TOWING LOAD/SPECIFICATION CHART

TOWING LOAD/SPECIFICATION CHART		Unit: lb (kg)
WEIGHT	MODEL	VQ35DE, VK45DE
		A/T
MAXIMUM TRAILER WEIGHT*1		3,500 (1,588)
MAXIMUM TONGUE LOAD		350 (159)
GROSS COMBINED WEIGHT RATING	VQ35DE	8,000 (3,629)
	VK45DE	8,100 (3,674)
RECOMMENDED EQUIPMENT*2		Sway Control Device (SCD)

*1: All towing above 1,000 lb (454 kg) requires the use of trailer brakes. INFINITI recommends the use of a tandem axle trailer whenever towing above 3,000 lb (1,361 kg).

*2: A sway control device is recommended for all towing above 2,000 lb (907 kg). Sway control devices are not offered by INFINITI. See a professional trailer/hitch outlet for a properly designed sway control device for your trailer.

TOWING SAFETY

Trailer hitch

Check the towing capacity of your receiver type frame mounted hitch. Choose a proper hitch for your vehicle and trailer. A genuine INFINITI trailer hitch is available from your INFINITI dealer (US only). Make sure the trailer hitch is securely attached to the vehicle, to help avoid personal injury or property damage due to sway caused by crosswinds, rough road surfaces or passing trucks.



CAUTION

- **Special hitches which include frame reinforcements are required for towing above 2,000 lb (907 kg). Suitable Genuine INFINITI hitches for pickup truck and sport utility vehicles are available at a INFINITI dealer.**
- **Do not use axle-mounted hitches.**
- **Do not modify the vehicle exhaust system, brake system, etc. to install a trailer hitch.**

- **After the hitch is removed, seal the bolt holes to prevent exhaust fumes, water or dust from entering the passenger compartment.**
- **Regularly check all hitch mounting bolts are securely mounted.**
- **To reduce the possibility of additional damage if your vehicle is struck from the rear, where practical, remove the hitch and/or receiver when not in use.**
- **Never connect a trailer brake system directly to the vehicle brake system.**

Tire pressures

- When towing a trailer, inflate the vehicle tires to the recommended cold tire pressure indicated on the tire placard (located on the driver side center pillar).
- Trailer tire condition, size, load rating and proper inflation pressure should be in accordance with the trailer and tire manufacturers' specifications.

Safety chains

Always use a suitable chain between your

vehicle and the trailer. The safety chain should be crossed and should be attached to the hitch, not to the vehicle bumper or axle. Be sure to leave enough slack in the chain to permit turning corners.

Trailer lights

Trailer lights should comply with federal and/or local regulations. When wiring the vehicle for towing, connect the stop and tail light pickup into the vehicle electrical circuit at a point between the sensor and stop light or light switch.

Trailer brakes

If your trailer is equipped with a braking system, make sure it conforms to federal and/or local regulations and that it is properly installed.



WARNING

Never connect a trailer brake system directly to the vehicle brake system.

Pre-towing tips

- Be certain your vehicle maintains a level position when a loaded and/or unloaded

trailer is hitched. Do not drive the vehicle if it has an abnormal nose-up or nose-down condition; check for improper tongue load, overload, worn suspension or other possible causes of either condition.

- Always secure items in the trailer to prevent load shifts while driving.
- Be certain your rear view mirrors conform to all federal, state or local regulations. If not, install any mirrors required for towing before driving the vehicle.

Trailer towing tips

In order to gain skill and an understanding of the vehicle's behavior, you should practice turning, stopping and backing up in an area which is free from traffic. Steering stability, and braking performance will be somewhat different than under normal driving conditions.

- Always secure items in the trailer to prevent load shift while driving.
- Avoid abrupt starts, acceleration or stops.
- Avoid sharp turns or lane changes.
- Always drive your vehicle at a moderate speed.
- Always block the wheels on both vehicle and trailer when parking. Parking on a

slope is not recommended; however, if you must do so, first apply the parking brake and block the wheels, and then move the transmission selector lever into the P (Park) position. If you move the selector lever to the P (Park) position before blocking the wheels and applying the parking brake, the transmission may get damaged.

- When going down a hill, shift into a lower gear and use the engine braking effect. When ascending on a long grade, downshift the transmission to a lower gear and reduce speed to reduce chances of engine overloading and/or overheating.
- If the engine coolant rises to an extremely high temperature when the air conditioning system is on, turn off the air conditioner. Coolant heat can be additionally vented by opening the windows, switching the fan control to high and setting the temperature control to the HOT position.
- Trailer towing consumes more fuel than normal circumstances.
- Avoid towing a trailer for the first 500 miles (800 km).
- Have your vehicle serviced more often than at intervals specified in the recommended maintenance schedule.

- When making a turn, your trailer wheels will be closer to the inside of the turn than your vehicle wheels. To compensate for this, make a larger than normal turning radius during the turn.
- Crosswinds and rough roads will adversely affect vehicle/trailer handling, possibly causing vehicle sway. When being passed by larger vehicles, be prepared for possible changes in crosswinds that could affect vehicle handling. If swaying does occur, firmly grip the steering wheel, steer straight ahead, and immediately (but gradually) reduce vehicle speed. This combination will help stabilize the vehicle. Never increase speed.
- Be careful when passing other vehicles. Passing while towing a trailer requires considerably more distance than normal passing. Remember the length of the trailer must also pass the other vehicle before you can safely change lanes.
- To maintain engine braking efficiency and electrical charging performance, do not use or overdrive (automatic transmission).
- Avoid holding the brake pedal down too long or too frequently. This could cause the brakes to overheat, resulting in reduced braking efficiency.

When towing a trailer, change transmission oil more frequently.

FLAT TOWING

Towing your vehicle with all four wheels on the ground is sometimes called flat towing. This method is sometimes used when towing a vehicle behind a recreational vehicle, such as a motor home.



CAUTION

- **Failure to follow these guidelines can result in severe transmission damage.**
- **Whenever flat towing your vehicle, always tow forward, never backward.**
- **DO NOT tow any automatic transmission vehicle with all four wheels on the ground (flat towing). Doing so WILL DAMAGE internal transmission parts due to lack of transmission lubrication.**

- For emergency towing procedures see “Towing recommended by INFINITI” in the “6. In case of emergency” section of this manual. Refer to “Towing recommended by INFINITI” earlier in this chapter.

To tow a vehicle equipped with an automatic transmission, an appropriate vehicle dolly **MUST** be placed under the towed vehicle’s drive wheels. **Always** follow the dolly manufacturer’s recommendations when using their product.

UNIFORM TIRE QUALITY GRADING

DOT (Department Of Transportation) Quality Grades: All passenger car tires must conform to federal safety requirements in addition to these grades.

Quality grades can be found where applicable on the tire sidewall between tread shoulder and maximum section width. For example:

Treadwear 200 Traction AA Temperature A

Treadwear

Treadwear grade is a comparative rating based on tire wear rate when tested under controlled conditions on specified government test courses. For example, a tire graded 150 would wear one and a half (1-1/2) times as well on the government course as a tire graded 100. However, relative tire performance depends on actual driving conditions, and may vary significantly from the norm due to variations in driving habits, service practices and differences in road characteristics and climate.

Traction AA, A, B and C

The traction grades, from highest to lowest, are AA, A, B, and C. Those grades represent the tire’s ability to stop on wet pavement as measured under controlled conditions on specified government test surfaces of asphalt

and concrete. A tire marked C may have poor traction performance.



WARNING

The traction grade assigned to your vehicle tires is based on straight-ahead braking traction tests, and does not include acceleration, cornering, hydroplaning, or peak traction characteristics.

Temperature A, B and C

Temperature grades are A (the highest), B, and C. They represent a tire’s resistance to heat build-up, and its ability to dissipate heat when tested under controlled conditions on a specified indoor laboratory test wheel. Sustained high temperature can cause tire material to degenerate, reducing tire life. Excessive temperatures can lead to sudden tire failure. Grade C corresponds to a performance level which all passenger car tires must meet under the Federal Motor Vehicle Safety Standard No. 109. Grades A and B represent higher levels of performance on laboratory test wheels than the minimum required by law.



WARNING

The temperature grade for this tire is established for a tire that is properly inflated and not overloaded. Excessive speed, underinflation, or excessive loading, either separately or in combination, can cause heat buildup and possible tire failure.

EMISSION CONTROL SYSTEM WARRANTY

Your INFINITI is covered by the following emission warranties.

For US:

- Emission Defects Warranty
- Emissions Performance Warranty (See Warranty Information Booklet for details.)

For Canada:

Emission Control System Warranty

Details of these warranties may be found with other vehicle warranties in your Warranty Information Booklet (Warranty and Roadside Assistance Information (Canada only)) that comes with your INFINITI. If you did not receive a Warranty Information Booklet (Warranty and Roadside Assistance Information (Canada only)), or it has become lost, you may obtain a replacement by writing to:

- INFINITI Division
Nissan North America, Inc.
Consumer Affairs Department
P.O. Box 47038, Gardena, CA 90247-6838
- Nissan Canada Inc.
5290 Orbitor Drive
Mississauga, Ontario, L4W 4Z5

REPORTING SAFETY DEFECTS (US only)

If you believe that your vehicle has a defect which could cause a crash or could cause injury or death, you should immediately inform the National Highway Traffic Safety Administration (NHTSA) in addition to notifying INFINITI.

If NHTSA receives similar complaints, it may open an investigation, and if it finds that a safety defect exists in a group of vehicles, it may order a recall and remedy campaign. However, NHTSA cannot become involved in individual problems between you, your dealer, or INFINITI.

To contact NHTSA, you may call the Auto Safety Hotline toll-free at 1-888-327-4236. You may also write to: NHTSA, U.S. Department of Transportation, Washington, D.C. 20590. You can also obtain other information about motor vehicle safety from the Hotline.

You may notify INFINITI by contacting our Consumer Affairs Department, toll-free, at 1-800-662-6200.

READINESS FOR INSPECTION/ MAINTENANCE (I/M) TEST (US only)

Due to legal requirements in some states/ areas, your vehicle may be required to be in what is called the “ready condition” for an Inspection/Maintenance (I/M) test of the emission control system.

The vehicle is set to the “ready condition” when it is driven through certain driving patterns. Usually, the “ready condition” can be obtained by ordinary usage of the vehicle.

If a powertrain system component is repaired or the battery is disconnected, the vehicle may be reset to a not “ready condition”. Before taking the I/M test, drive the vehicle through the following pattern to set the vehicle to the ready condition. If you cannot or do not want to perform the driving pattern, an INFINITI dealer can conduct it for you.



WARNING

Always drive the vehicle in a safe and prudent manner according to traffic conditions, and obey all traffic laws.

1. Start the engine. Allow the engine to idle until the engine coolant temperature gauge needle points between the C and H (normal operating temperature).

2. Accelerate the vehicle to 55 MPH (88 km/h), then quickly release the accelerator pedal completely and keep it released for at least 6 seconds.

3. Quickly depress the accelerator pedal for a moment, then drive the vehicle at a speed of 53 to 60 MPH (86 to 96 km/h) for at least 5 minutes.

4. Stop the vehicle. Leave the engine running.

5. Accelerate the vehicle to 35 MPH (55 km/h) and maintain the speed for 20 seconds.

6. Repeat steps 4 and 5 at least 3 times.

7. Accelerate the vehicle to 55 MPH (88 km/h) and maintain the speed for at least 3 minutes.

8. Stop the vehicle. Place the transmission gear selector lever in the “P” or “N” position.

9. Rev the engine up between 2,500 and 3,500 rpm and hold it there for 3 consecutive minutes, then release the accelerator pedal completely.

10. Wait 5 seconds with the engine at idle.

11. Rev the engine up between 2,000 and 3,000 rpm and maintain that speed for 5 consecutive minutes.

12. Turn the engine off.

13. Repeat steps 1 through 8 at least one more time.

If step 1 through 7 is interrupted, repeat the preceding step. Any safe driving mode is acceptable between steps. Do not stop the engine until step 7 is completed.

EVENT DATA RECORDERS

Your vehicle is equipped with a variety of computers that monitor and control a number of systems to optimize performance and help service technicians with diagnosis and repair. Depending on the equipment on your vehicle, some of the computers monitor emission control systems, braking systems and air bag systems, just to name a few. Some data about vehicle operation may be stored in the computers for use during servicing. Other data may be stored if a crash event occurs. For example, air bag readiness, air bag performance, and seat belt use by the driver or passenger may be recorded, depending on vehicle equipment. These types of systems are sometimes called Event Data Recorders.

Special equipment can be used to access the electronic data that may be stored in the vehicle's computers (sounds are not recorded). INFINITI and INFINITI dealers have equipment to access some of this data; others may also have this equipment. The data may be retrieved during routine vehicle servicing or for special research. It might also be accessed with the consent of the vehicle owner or lessee in response to a request by law enforcement, or as otherwise required or permitted by law.

OWNER'S MANUAL/SERVICE MANUAL ORDER INFORMATION

A genuine INFINITI Service Manual is the best source of service and repair information for your vehicle. Filled with wiring diagrams, illustrations and step-by-step diagnostic and adjustment procedures, this manual is the same one used by the factory trained technicians working at authorized INFINITI dealerships. Also available are genuine INFINITI Owner's Manuals, and genuine INFINITI Service and Owner's Manuals for older INFINITI models.

In the USA:

For current pricing and availability of genuine **INFINITI Service Manuals** for the 2000 model year and later, contact:

Tweddle Litho Company
1-800-450-9491
www.nissan-techinfo.com

For current pricing and availability of genuine **INFINITI Service Manuals** for the 1999 model year and prior, see an INFINITI dealer, or contact:

DDS Distribution Services, Ltd.
20770 Westwood Road
Strongsville, OH 44136
1-800-247-5321

For current pricing and availability of genuine **INFINITI Owner's Manuals** for the 2004

model year and prior, see an INFINITI dealer, or contact:

DDS Distribution Services, Ltd.
20770 Westwood Road
Strongsville, OH 44136
1-800-247-5321

In Canada:

To purchase a copy of a genuine INFINITI Service Manual or Owner's Manual please contact your nearest INFINITI dealer. For the phone number and location of an INFINITI dealer in your area call the INFINITI Satisfaction Center at 1-800-361-4792 and a bilingual INFINITI representative will assist you.

Also available are genuine INFINITI Service and Owner's Manuals for older INFINITI models.

IN THE EVENT OF A COLLISION

Unfortunately, accidents do occur. In this unlikely event, there is some important information you should know. Many insurance companies routinely authorize the use of non-genuine collision parts in order to cut costs, among other reasons.

Insist on the use of Genuine INFINITI Collision Parts!

If you want your vehicle to be restored using parts made to INFINITI's original exacting specifications — if you want to help it to last and hold its resale value, the solution is simple. **Tell your insurance agent and your repair shop to only use Genuine INFINITI Collision Parts.** INFINITI does not warrant non-INFINITI parts, nor does INFINITI's warranty apply to damage caused by a non-genuine parts.

Using Genuine INFINITI Parts can help protect your personal safety, preserve your warranty protection and maintain the resale value of your vehicle. And if your vehicle was leased, using Genuine INFINITI Parts may prevent or limit unnecessary excess wear and tear expenses at the end of your lease.

INFINITI designs its hoods with crumple zones to minimize the risk that the hood will penetrate the windshield of your vehicle in an accident. Non-genuine (imitation) parts may not provide such built in safety features. Also, non-genuine parts often show premature wear, rust and corrosion.

Why should you take a chance?

In over 40 states and certain territories/provinces, the law says you must be advised if non-genuine parts are used to repair your vehicle. And some states and provinces have enacted laws that restrict insurance companies from authorizing the use of non-genuine collision parts during the new vehicle warranty. These laws help protect you, so you can take action to protect yourself.

It's your right!

10 Index

A

ABS (Anti-lock brake system).....	5-44
Aiming control, Headlights.....	2-23
Air bag system, Side and curtain (See supplemental side air bag and curtain side-impact air bag system).....	1-16
Air bag warning labels.....	1-19
Air bag warning light.....	1-19, 2-13
Air cleaner housing filter.....	8-20
Air conditioner	
Air conditioner operation.....	4-18
Air conditioner service.....	4-18, 4-21
Air conditioner specification label.....	9-13
Air conditioning system refrigerant and lubricant recommendations.....	4-21, 9-7
Heater and air conditioner (automatic).....	4-18
In-cabin microfilter.....	4-21
Alcohol, drugs and driving.....	5-5
Anchor point locations, Top tether strap.....	1-41
Antenna.....	4-43
Anti-lock Brake System (ABS).....	5-44
Anti-lock brake warning light.....	2-9
Appearance care	
Exterior appearance care.....	7-2
Interior appearance care.....	7-3
Armrest.....	1-7
Ashtray (See cigarette lighter and ashtray)....	2-30
Audible reminders.....	2-15
Audio operation precautions.....	4-23
Audio system.....	4-22
Autochanger	
Compact Disc (CD).....	4-30
Autolight system.....	2-22
Automatic	
Anti-glare inside mirror.....	3-32
Automatic sunroof.....	2-36
Automatic transmission fluid (ATF).....	8-15
Automatic transmission position indicator light.....	2-14
Drive positioner.....	3-33
Driving with automatic transmission.....	5-12
Seat positioner, seat.....	3-33
Transmission selector lever lock release.....	5-15
Avoiding collision and rollover.....	5-5
AWD (all wheel drive) warning light.....	2-10

B

Back door.....	3-25
Battery.....	8-17
Battery saver system.....	2-23
Battery replacement	
Intelligent Key system.....	3-8, 3-20
Remote keyless entry system.....	3-8, 3-20
Before starting the engine.....	5-11
Belts (See drive belts).....	8-18

Brake

Anti-lock brake system (ABS).....	5-44
Brake assist (for Intelligent cruise control system).....	5-37
Brake booster.....	8-23
Brake fluid.....	8-15
Brake pedal.....	8-22
Brake pedal check.....	8-22
Brake system.....	5-44
Parking brake check.....	5-15, 8-22
Parking brake operation.....	5-15
Warning light.....	2-10
Break-in schedule.....	5-40
Brightness control, Instrument panel.....	2-24
Bulb check/instrument panel.....	2-9
Bulb replacement.....	8-27

C

Cabin air filter.....	4-21
Capacities and recommended fuel/lubricants...	9-2
Car phone or CB radio.....	4-43
Card holder.....	2-34
Cargo (See vehicle loading information).....	2-34
Cargo net.....	2-34
Cassette player (See audio system).....	4-29
Catalytic converter, Three way catalyst.....	5-3
CD care and cleaning.....	4-32
Child restraints.....	1-32

Installation on front passenger seat.....	1-41
Installation on rear seat outboard or center positions	1-34
Precautions on child restraints.....	1-32
Top tether strap anchor point locations	1-41
With top tether strap.....	1-40
Child safety	1-24
Child safety rear door lock.....	3-5
Chimes	
Audible reminders	2-15
Seat belt warning light and chime.....	2-13
Cigarette lighter and ashtray	2-30
Circuit breaker, Fusible link	8-24
Cleaning exterior and interior	7-2, 7-3
Clock	2-28
Cold weather driving.....	5-47
Compact Disc (CD) changer operation	4-30
Compact spare tire	8-40
Compass display	2-6
Console box.....	2-33
Control panel buttons (models with navigation system)	4-7
Control panel buttons (models without navigation system)	4-2
Controls	
Control panel buttons (display with navigation system)	4-7
Control panel buttons (display without navigation system)	4-2
Heater and air conditioner controls (automatic).....	4-18
Coolant	
Capacities and recommended fuel/lubricants	9-2
Changing engine coolant	8-10

Checking engine coolant level	8-9
Corrosion protection	7-5
Cruise control.....	5-16
Cruise control, Fixed speed cruise control (on ICC system).....	5-34
Cruise control, Intelligent cruise control system.....	5-18
Cup holders	2-31
Curtain side-impact air bag system (See supplemental side air bag and curtain side-impact air bag system).....	1-16
CVT, Transmission selector lever lock release	5-15

D

Daytime running light system	2-24
Defroster switch, Rear window and outside mirror defroster switch.....	2-20
Dimensions and weights.....	9-10
Display controls (See control panel buttons), With navigation system	4-7
Display controls (See control panel buttons), Without navigation system.....	4-2
Door open warning light	2-11
Drive belts.....	8-18
Drive positioner, Automatic.....	3-33
Driving	
Cold weather driving	5-47
Driving with automatic transmission.....	5-12
On-pavement and offroad driving	5-3
Precautions when starting and driving.....	5-2
Safety precautions.....	5-5

DVD player, Infiniti mobile entertainment system.....	4-34
---	------

E

Economy, Fuel.....	5-40
Emission control information label.....	9-13
Emission control system warranty	9-23
Engine	
Before starting the engine.....	5-11
Break-in schedule.....	5-40
Capacities and recommended fuel/lubricants	9-2
Changing engine coolant	8-10
Changing engine oil and filter	8-12
Checking engine coolant level	8-9
Checking engine oil level	8-11
Coolant temperature gauge	2-5
Engine block heater	5-49
Engine compartment check locations	8-7
Engine cooling system	8-9
Engine oil.....	8-11
Engine oil and oil filter recommendation.....	9-5
Engine oil viscosity	9-5
Engine serial number	9-12
Engine specifications.....	9-8
If your vehicle overheats	6-11
Starting the engine	5-11
Event Data Recorders	9-25
Exhaust gas (Carbon monoxide).....	5-2

F

F.M.V.S.S. certification label.....	9-12
-------------------------------------	------

Filter	
Air cleaner housing filter	8-20
Changing engine oil and filter	8-12
Flashers (See hazard warning flasher switch)	2-25
Flat tire	6-2
Flat tire, Low tire pressure warning system	5-3, 5-4
Flat towing	9-21
Floor mat cleaning	7-4
Fluid	
Automatic transmission fluid (ATF)	8-15
Brake fluid	8-15
Capacities and recommended fuel/lubricants	9-2
Engine coolant	8-9
Engine oil	8-11
Power steering fluid	8-15
Window washer fluid	8-16
FM-AM-SAT radio with cassette player and Compact Disc (CD) changer	4-26
Fog light switch	2-25
Front power seat adjustment	1-2
Fuel	
Capacities and recommended fuel/lubricants	9-2
filler cap	3-27
filler lid	3-27
Fuel economy	5-40
Fuel octane rating	9-3
Fuel recommendation	9-3
Gauge	2-5
Fuses	8-23
Fusible links	8-24

G

Garage door opener, HomeLink® Universal Transceiver	2-40
Gas cap	3-27
Gauge	2-3
Engine coolant temperature gauge	2-5
Fuel gauge	2-5
Odometer	2-4
Speedometer	2-4
Tachometer	2-4
General maintenance	8-2
Glove box	2-32
Glove box lock	2-32

H

Hazard warning flasher switch	2-25
Head restraints	1-6
Headlights	
Aiming control	2-23
Bulb replacement	8-28
Headlight switch	2-21
Xenon headlights	2-20
Headphones (See Infiniti mobile entertainment system)	4-37
Heated seats	2-26
Heater	
Engine coolant heater	5-49
Heater and air conditioner (automatic)	4-18
HomeLink® Universal Transceiver	2-40
Hood release	3-25
Horn	2-26

How to stop alarm, Vehicle security systems	2-17
---	------

I

Ignition knob (Intelligent Key system)	3-13, 5-9
Ignition knob positions	5-10
Ignition switch	
(except Intelligent Key system)	5-8
Automatic transmission models	5-12
Key positions	5-8
Immobilizer system	2-17
In-cabin microfilter	4-21
Indicator lights	2-14
Infiniti mobile entertainment system (MES)	4-34
Infiniti Vehicle Immobilizer System	
Engine start	5-9, 5-10
Inside	
Automatic anti-glare mirror	3-32
Mirror	3-31
Inspection/maintenance (I/M) test	9-24
Instrument brightness control	2-24
Instrument panel	2-2
Intelligent cruise control (ICC) system	5-18
Intelligent cruise control (ICC) system, Brake assist	5-37
Intelligent cruise control (ICC) system, Preview function	5-44
Intelligent Key system	3-9
Intelligent Key system, Engine starting	3-13
Intelligent Key system, Key operating range	3-15
Intelligent Key system, Key operation	3-12

Intelligent Key system, Mechanical key and valet key	3-24
Intelligent Key system, Operating the engine	3-13
Intelligent Key system, Remote keyless operation	3-21
Intelligent Key system, Trouble-shooting guide	3-19
Intelligent Key system, Warning light	2-13
Intelligent Key system, Warning signals.....	3-17
Intelligent key warning light	2-13
Interior light.....	2-38, 2-39
Interior light replacement	8-28
ISOFIX child restraint	1-39

J

Jump starting	6-8
---------------------	-----

K

Keyless entry	
With Intelligent Key system (See Intelligent Key system).....	3-21
Without Intelligent Key system (See remote keyless entry system).....	3-5
Keys, Except Intelligent Key	3-2
Keys, For Intelligent Key system	3-9
Knob, Ignition knob (Intelligent Key system)....	5-9

L

Label, Air conditioner specification label	9-13
Label, Emission control information label.....	9-13

Label, F.M.V.S.S. certification label.....	9-12
Labels	
Air bag warning labels.....	1-19
Engine serial number	9-12
Vehicle identification number (VIN).....	9-11
LATCH system.....	1-39
License plate, Installing front license plate.....	9-14
Light	
Air bag warning light	1-19
Bulb replacement	8-27
Fog light switch	2-25
Headlight switch	2-21
Headlights Bulb replacement	8-28
Interior light.....	2-38
Map lights	2-38
Personal light.....	2-39
Replacement	8-27
Vanity mirror light	2-40
Warning/indicator lights and audible reminders	2-9, 2-14
Xenon headlights.....	2-20
Lights, Exterior and interior light replacement	8-28
Loading information (See vehicle loading information)	9-15
Lock	
Back door lock.....	3-25
Door locks	3-3
Glove box lock.....	2-32
Power door lock	3-3
Low tire pressure warning light.....	2-12
Low tire pressure warning system	5-3, 5-4, 6-2

M

Maintenance	
Battery	8-17
General maintenance	8-2
Inside the vehicle	8-4
Maintenance precautions	8-5
Maintenance requirements	8-2
Outside the vehicle.....	8-3
Seat belt maintenance	1-31
Under the hood and vehicle.....	8-4
Malfunction indicator lamp (MIL)	2-14
Map lights	2-38
Mechanical key (for Intelligent Key system)...	3-24
Meters and gauges.....	2-3
Meters and gauges, Instrument brightness control	2-24
Mirror	
Automatic anti-glare inside mirror	3-32
Inside mirror	3-31
Outside mirror control.....	3-32
Outside mirrors.....	3-32
Mobile entertainment system (MES)	4-34

N

Net, Cargo net	2-34
New vehicle break-in	5-40
Nissan Vehicle Immobilizer System	2-16

O

Odometer	2-4
----------------	-----

Oil	
Capacities and recommended fuel/lubricants	9-2
Changing engine oil and filter	8-12
Checking engine oil level	8-11
Engine oil	8-11
Engine oil viscosity	9-5
Operating the engine (Intelligent Key system)	3-13
Outside mirror control	3-32
Outside mirrors	3-32
Overheat, If your vehicle overheats.....	6-11
Owner's Manual/Service Manual order information	9-25

P

Parking	
Brake check.....	8-22
Parking brake check.....	5-15
Parking brake operation	5-15
Parking on hills.....	5-15
Parking/parking on hills	5-42
Personal light	2-39
Phone, Car phone or CB radio.....	4-43
Power	
Front seat adjustment	1-2
Power door lock	3-3
Power outlet	2-29
Power steering fluid.....	8-15
Power steering system.....	5-43
Power windows	2-35
Pre-tensioner seat belt system.....	1-18

Precautions	
Audio operation	4-23
Braking precautions.....	5-44
Child restraints	1-32
Cruise control	5-16
Driving safety.....	5-5
Maintenance	8-5
On-pavement and offroad driving	5-3
Seat belt usage	1-21
Supplemental restraint system.....	1-8
When starting and driving	5-2
Preview function (for Intelligent cruise control system)	5-44
Push starting.....	6-11

R

Radio	
Car phone or CB radio.....	4-43
FM-AM radio with cassette player and Compact Disc (CD) changer.....	4-26
Readiness for inspection/maintenance (I/M) test (US only)	9-24
Rear center seat belt	1-28
Rear door lock, Child safety rear door lock.....	3-5
Rear power point	2-29
Rear seat adjustment	1-4
Rear window and outside mirror defroster switch	2-20
Rear window wiper and washer switch	2-19
Rearview monitor.....	4-15
Registering your vehicle in another country ...	9-11
Remote controller (See Infiniti mobile entertainment system)	4-35

Remote keyless entry	
System, Except Intelligent Key system.....	3-5
System, For Intelligent Key system	3-21
Reporting safety defects (US only).....	9-23
Roadside assistance program	6-2
Rollover.....	5-5

S

Safety	
Child seat belts.....	1-24
Reporting safety defects (US only)	9-23
Towing safety	9-19, 9-21
Screen (See Infiniti mobile entertainment system)	4-36
Seat	
Belt warning light.....	1-21
Belt warning light and chime	2-13
Seat adjustment	
Front power seat adjustment	1-2
Rear seat adjustment.....	1-4
Seat belt(s)	
Child safety.....	1-24
Infants and small children	1-24
Injured persons.....	1-25
Larger children	1-24
Pre-tensioner seat belt system	1-18
Precautions on seat belt usage	1-21
Pregnant women	1-25
Rear center seat belt.....	1-28
Seat belt cleaning.....	7-4
Seat belt extenders	1-31
Seat belt maintenance	1-31
Seat belts	1-21

Transmission	
Automatic transmission fluid (ATF)	8-15
Driving with automatic transmission.....	5-12
Transmission selector lever lock release.....	5-15
Transmitter, With Intelligent Key system (See Intelligent Key system).....	3-21
Transmitter, Without Intelligent Key system (See remote keyless entry system).....	3-5
Traveling or registering your vehicle in another country	9-11
Trouble-shooting guide (for Intelligent Key system)	3-19
Turn signal switch.....	2-25

U

Underbody cleaning.....	7-3
Uniform tire quality grading.....	9-22

V

Valet key (for Intelligent Key system).....	3-24
Vanity mirror light.....	2-40
Vehicle	
Dimensions and weights	9-10
Identification number (VIN)	9-11
Loading information.....	9-15
Recovery (freeing a stuck vehicle).....	6-14
Security system	2-16
Vehicle dynamic control (VDC) off switch.....	2-28
Vehicle dynamic control (VDC) system	5-46
Vehicle electronic systems	4-10

Vehicle load capacity	9-16
Ventilators	4-16

W

Warning labels, Air bag warning labels.....	1-19
Warning light	
Air bag warning light	1-19, 2-13
Anti-lock brake warning light.....	2-9
AWD (all wheel drive) warning light.....	2-10
AWD warning light.....	5-41
Brake warning light.....	2-10
Door open warning light.....	2-11
Intelligent Key warning light	2-13
Low tire pressure warning light.....	2-12
Seat belt warning light and chime.....	2-13
Warning lights	2-9
Warning, Hazard warning flasher switch.....	2-25
Warning, Low tire pressure warning system.....	5-3, 5-4, 6-2
Warning, Warning/indicator lights and audible reminders	2-9
Warranty, Emission control system warranty	9-23
Washer switch	
Rear window wiper and washer switch.....	2-19
Windshield wiper and washer switch	2-19
Washing	7-2
Waxing	7-2
Weights (See dimensions and weights)	9-10
Wheel/tire size	9-10
Wheels and tires.....	8-32
Cleaning aluminum alloy wheels.....	7-3
Window washer fluid.....	8-16

Window(s)	
Cleaning	7-3
Power windows	2-35
Windshield wiper and washer switch.....	2-19
Wiper	
Rear window wiper and washer switch.....	2-19
Rear window wiper blade.....	8-22
Windshield wiper and washer switch	2-19
Wiper blades	8-20

X

Xenon headlights	2-20
------------------------	------

MEMO

10-8

MEMO

MEMO

10-10

MEMO

MEMO

10-12

GAS STATION INFORMATION

FUEL RECOMMENDATION:

VK45 engine

In order to maintain engine and exhaust system durability and performance, unleaded premium gasoline with an octane rating of at least 91 AKI (Anti-Knock Index) number (Research octane number 96) must be used.

If premium gasoline is not available, unleaded regular gasoline with an octane rating of 87 AKI number (Research octane number 91) may be temporarily used, but only under the following precautions:

- Have the fuel tank filled only partially with unleaded regular gasoline, and fill up with unleaded premium gasoline as soon as possible.
- Avoid full throttle driving and abrupt acceleration

VQ35 engine

Use unleaded regular gasoline with an octane rating of at least 87 AKI (Anti-Knock Index) number (Research octane number 91).

For improved vehicle performance, INFINITI recommends the use of unleaded premium gasoline with an octane rating of at least 91 AKI number (Research octane number 96).



CAUTION

Using a fuel other than that specified could adversely affect the emission control systems, and may also affect warranty coverage.

Under no circumstances should a leaded gasoline be used, since this will damage the three way catalyst.

For additional information, see “Capacities and recommended fuel/lubricants” in the “9. Technical and consumer information” section.

ENGINE OIL RECOMMENDATION:

For VK45DE engine

- API Certification Mark
- API grade SJ or SL, Energy Conserving
- ILSAC grade GF-II & GF-III
- SAE 5W-30 viscosity oil is preferred for all ambient temperatures. SAE 10W-30, 10W-40 viscosity oil may be used for ambient temperatures above 0°F (–18°C).

For VQ35DE engine

- API Certification Mark

- API grade SG/SH, Energy Conserving I & II or API grade SJ or SL, Energy Conserving
- ILSAC grade GF-I, GF-II & GF-III
- SAE 5W-30 viscosity oil is preferred for all ambient temperatures. SAE 10W-30, 10W-40 viscosity oil may be used for ambient temperatures above 0°F (–18°C).

See “Capacities and recommended fuel/lubricants” in the “9. Technical and consumer information” section for engine oil and oil filter recommendation.

COLD TIRE PRESSURES:

See tire placard affixed to the inside of the rear left door opening.

NEW VEHICLE BREAK-IN PROCEDURES RECOMMENDATION:

During the first 1,000 miles (1,600 km) of vehicle use, follow the recommendations outlined in the “Break-in schedule” Information found in the “5. Starting and driving” section of this Owner’s Manual. Follow these recommendations for the future reliability and economy of your new vehicle.

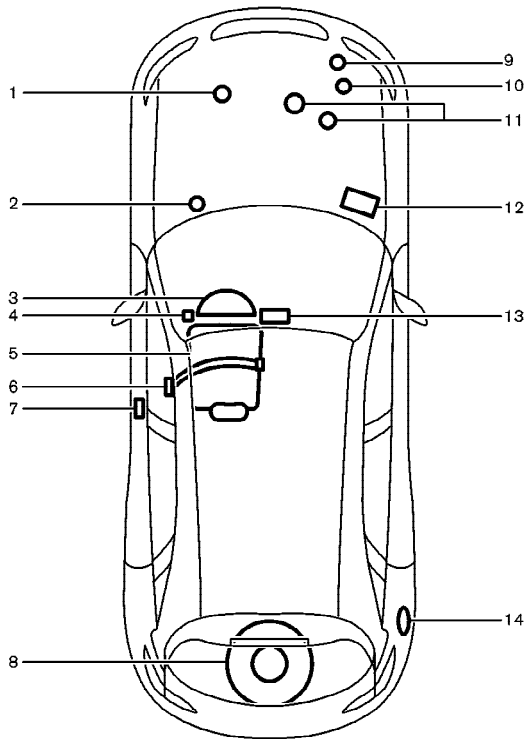

1. Engine oil (P.8-11)
2. Brake fluid (P.8-15)
3. Meters and gauges (P.2-3)
4. Hood release (P.3-25)
5. Trunk release (P.3-25)/Fuel filler lid release (P.3-27)
6. Seat belt (P.1-21)
7. Door lock/key (P.3-3)
8. Spare tire (P.6-4, P.8-40)
9. Windshield washer fluid (P.8-16)
10. Engine coolant (P.8-9)
11. Power steering fluid (P.8-15)
12. Battery (P.8-17)
13. Audio system (P.4-22)/Heater and air conditioner (P.4-18)
14. Fuel (P.3-27, P.9-2)