

## Foreword

Your INFINITI represents a new way of thinking about vehicle design. It integrates advanced engineering and superior craftsmanship with a simple, refined aesthetic sensitivity associated with traditional Japanese culture.

The result is a different notion of luxury and beauty. The car itself is important, but so is the sense of harmony that the vehicle evokes in its driver, and the sense of satisfaction you feel with the INFINITI — from the way it looks and drives to the high level of dealer service.

To ensure that you enjoy your INFINITI to the fullest, we encourage you to read this Owner's Manual immediately. It explains all of the features, controls and performance characteristics of your INFINITI; it also provides important instructions and safety information.

**A separate Warranty Information Booklet can be found in your Owner's literature portfolio. The INFINITI Service and Maintenance Guide explains details about maintaining and servicing your vehicle. Always carry it with you when you take your INFINITI to an authorized dealer. The portfolio contents provide complete information about all warranties covering this vehicle, the periodic maintenance required to keep the warranties in effect as**

**well as the INFINITI Roadside Assistance program.**

**Additionally, a separate Customer Care and Lemon Law Information Booklet will explain how to resolve any concerns you may have with your vehicle, as well as clarify your rights under your state's lemon law.**

INFINITI is dedicated to providing a satisfying ownership experience for as long as you own your car. Should you have any questions regarding your INFINITI or an INFINITI dealer, please contact our Consumer Affairs department at:  
In U.S. 1-800-662-6200  
In Canada 1-800-361-4792

### **READ FIRST — THEN DRIVE SAFELY**

**Before driving your vehicle please read your Owner's Manual carefully. This will ensure familiarity with controls and maintenance requirements, assisting you in the safe operation of your vehicle.**



## **WARNING**

### **IMPORTANT SAFETY INFORMATION REMINDERS FOR SAFETY!**

Follow these important driving rules to help ensure a safe and comfortable trip for you and your passengers!

- **NEVER** drive under the influence of alcohol or drugs.
- **ALWAYS** observe posted speed limits and never drive too fast for conditions.
- **ALWAYS** use your seat belts and appropriate child restraint systems. Preteen children should be seated in the rear seat.
- **ALWAYS** provide information about the proper use of vehicle safety features to all occupants of the vehicle.
- **ALWAYS** review this Owner's Manual for important safety information.

### **MODIFICATION OF YOUR VEHICLE**

This vehicle should not be modified. Modification could affect its performance, safety or durability, and may even violate governmental regulations. In addition, damage or performance problems resulting from modifications may not be covered under INFINITI warranties.

## WHEN READING THE MANUAL

This manual includes information for all options available on this model. Therefore, you may find some information that does not apply to your vehicle.

All information, specifications and illustrations in this manual are those in effect at the time of printing. INFINITI reserves the right to change specifications or design at any time without notice.

## IMPORTANT INFORMATION ABOUT THIS MANUAL

You will see various symbols in this manual. They are used in the following ways:



### WARNING

This is used to indicate the presence of a hazard that could cause death or serious personal injury. To avoid or reduce the risk, the procedures must be followed precisely.



### CAUTION

This is used to indicate the presence of a hazard that could cause minor or moderate personal injury or damage to your vehicle. To avoid or reduce the risk, the procedures must be followed carefully.

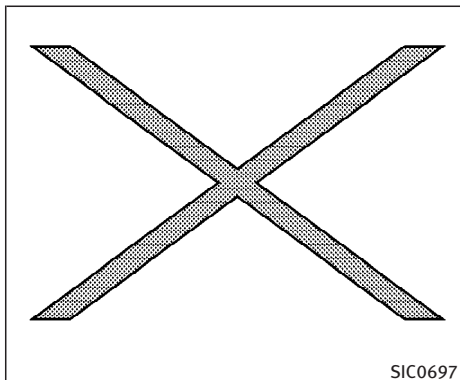

SIC0697

If you see this symbol, it means **Do not do this** or **Do not let this happen**.



If you see a symbol similar to these in an illustration, it means the arrow points to the front of the vehicle.



Arrows in an illustration that are similar to these indicate movement or action.



Arrows in an illustration that are similar to these call attention to an item in the illustration.

## CALIFORNIA PROPOSITION 65 WARNING



### WARNING

Engine exhaust, some of its constituents, and certain vehicle components contain or emit chemicals known to the State of California to cause cancer and birth defects or other reproductive harm. In addition, certain fluids contained in vehicles and certain products of component wear contain or emit chemicals known to the State of California to cause cancer and birth defects or other reproductive harm.



BLUETOOTH® is a trademark owned by Bluetooth SIG, Inc., U.S.A. and licenced to Xanavi Informatics Corporation.



INFINITI®

© 2005 NISSAN MOTOR CO., LTD.  
TOKYO, JAPAN

All rights reserved. No part of this Owner's Manual may be reproduced or stored in a retrieval system, or transmitted in any form, or by any means, electronic, mechanical, photocopying, recording or otherwise, without the prior written permission of Nissan Motor Co., Ltd.

# Table of Contents

Illustrated table of contents	0
Safety – Seats, seat belts and supplemental restraint system	1
Instruments and controls	2
Pre-driving checks and adjustments	3
Display screen, heater, air conditioner and audio systems	4
Starting and driving	5
In case of emergency	6
Appearance and care	7
Maintenance and do-it-yourself	8
Technical and consumer information	9
Index	10



# 0 Illustrated table of contents

Exterior .....	0-2	Engine compartment .....	0-5
Instrument panel.....	0-3	VQ35DE engine .....	0-5
Meters and gauges .....	0-4	VK45DE engine .....	0-6

## EXTERIOR

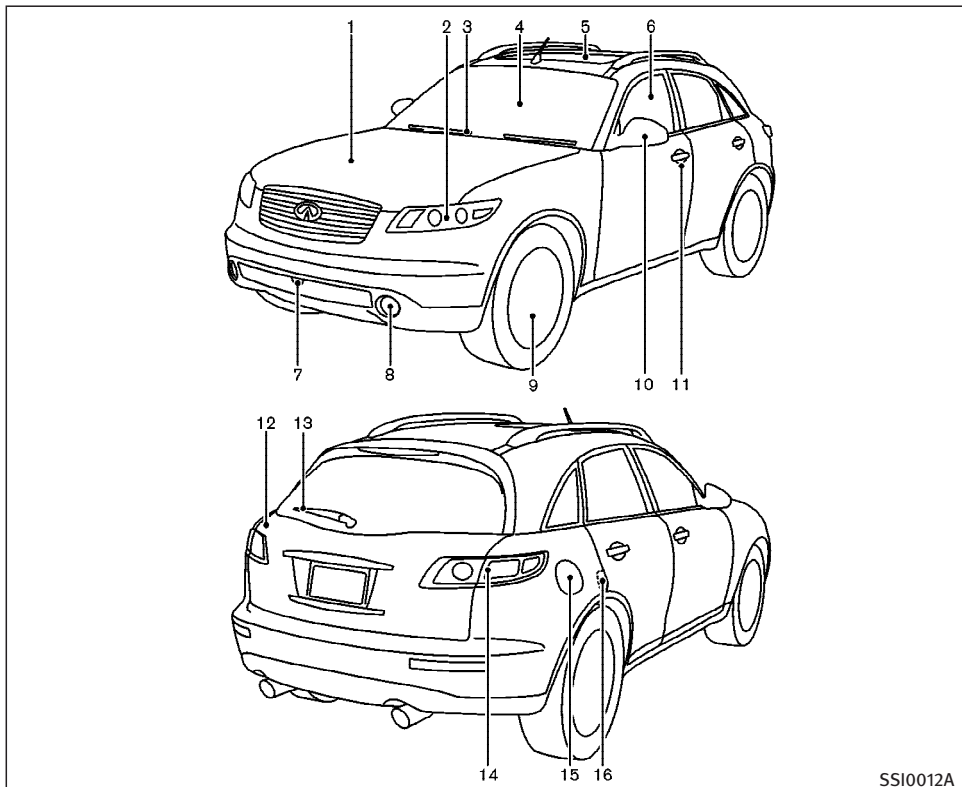

1. Hood (Page 3-24)
2. Headlight and turn signal switch (P.2-21)
3. Wiper and washer switch (P.2-21)
4. Windshield (P.8-21)
5. Sunroof (if so equipped) (P.2-43)
6. Power windows (P.2-41)
7. Recovery hook (P.6-16)
8. Fog light and switch (P.2-28)
9. Tires
  - Wheel and tires (P.8-35, 9-10)
  - Flat tire (P.6-2)
10. Mirrors (P.3-30)
11. Doors (P.3-3)
  - Keys
  - Door locks
  - Remote keyless entry system
  - Intelligent Key (if so equipped)
12. Lift gate (P.3-24)
13. Rear window wiper (P.8-23)
14. Rear combination light (P.8-33)
15. Fuel-filler door (P.3-26)
16. Child safety locks (P.3-5)

SSI0012A

## INSTRUMENT PANEL

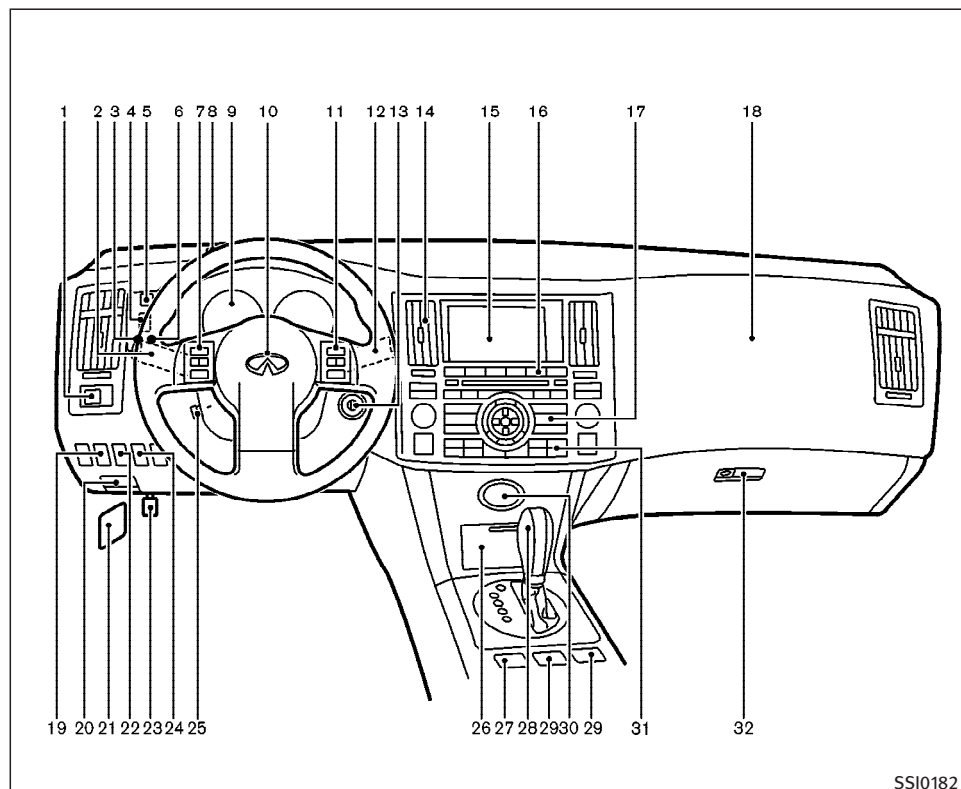

1. Outside mirror remote control (P.3-31)
2. Headlight, fog light and turn signal switch (P.2-23)
3. Trip odometer reset knob (P.2-4)
4. Instrument brightness control switch (P.2-25)
5. Headlight aiming control switch (P.2-26)
6. Trip odometer select knob (P.2-4)
7. Steering switch for Audio (P.4-40)/ Bluetooth<sup>®</sup> Hands-Free Phone System (if so equipped) (P.4-41)
8. Security indicator light (P.2-18)
9. Meters and gauges (P.2-3)
10. Driver supplemental air bag (P.1-37)
11. Cruise control main/set switch (P.5-22) or Intelligent cruise control switch (if so equipped) (P.5-24)
12. Windshield wiper/washer switch (P.2-21)
13. Ignition switch (P.3-14)
14. Center ventilator (P.4-20)
15. Display (P.4-4)/Navigation system (if so equipped)\*
16. Audio system (P.4-25)
17. Center multi-function control panel (P.4-2)
18. Front passenger supplemental air bag (P.1-37)

SSI0182

## METERS AND GAUGES

19. Lane departure warning (LDW) switch (if so equipped) (P.2-30)
20. Hood release handle (P.3-24)
21. Fuse box (P.8-24)
22. SNOW mode switch (P.2-31)
23. Parking brake (P.5-18)
24. Vehicle dynamic control (VDC) OFF switch (P.2-31)
25. Tilting/telescopic steering wheel switch (P.3-28)
26. Storage box and power outlet (P.2-33, P.2-35)
27. Hazard warning flasher switch (P.2-28)
28. Automatic transmission selector lever (P.5-14)
29. Heated seat switch (P.2-29)
30. Clock (P.2-32)
31. Automatic climate control system (P.4-21)
32. Glove box (P.2-36)

\*: Refer to the separate Navigation System Owner's Manual. (if so equipped)

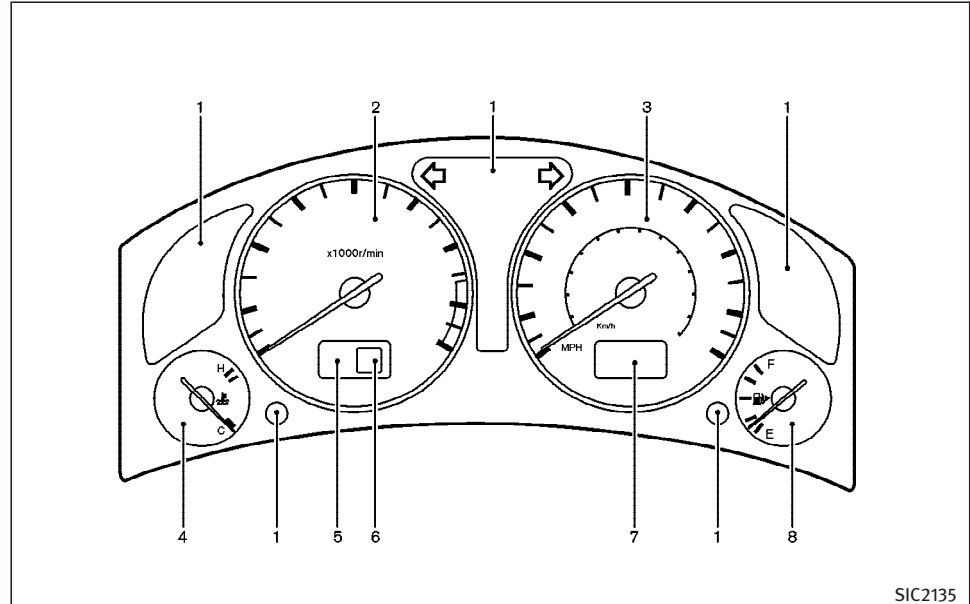

1. Warning/Indicator lights (P.2-9)
2. Tachometer (P.2-4)
3. Speedometer (P.2-4)
4. Engine coolant temperature gauge (P.2-5)
5. Intelligent cruise control system display (if so equipped) (P.5-24)
6. Automatic transmission position indicator (P.5-14)
7. Odometer (Total/Twin trip) (P.2-4)
8. Fuel gauge (P.2-5)



## ENGINE COMPARTMENT

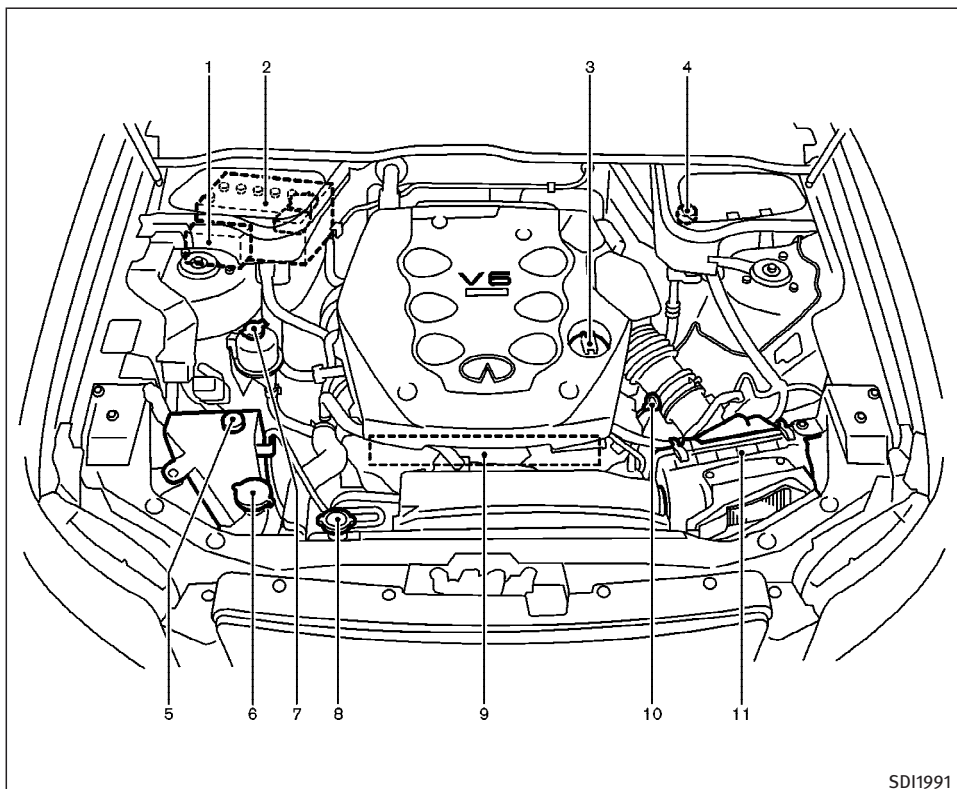

SD11991

## VQ35DE ENGINE

1. Fuse/fusible link holder (P.8-24)
2. Battery (P.8-17)
3. Engine oil filler cap (P.8-11)
4. Brake fluid reservoir (P.8-16)
5. Engine coolant reservoir (P.8-9)
6. Window washer fluid reservoir (P.8-16)
7. Power steering fluid reservoir (P.8-15)
8. Radiator filler cap (P.8-9)
9. Drive belts (P.8-19)
10. Engine oil dipstick (P.8-11)
11. Air cleaner (P.8-20)

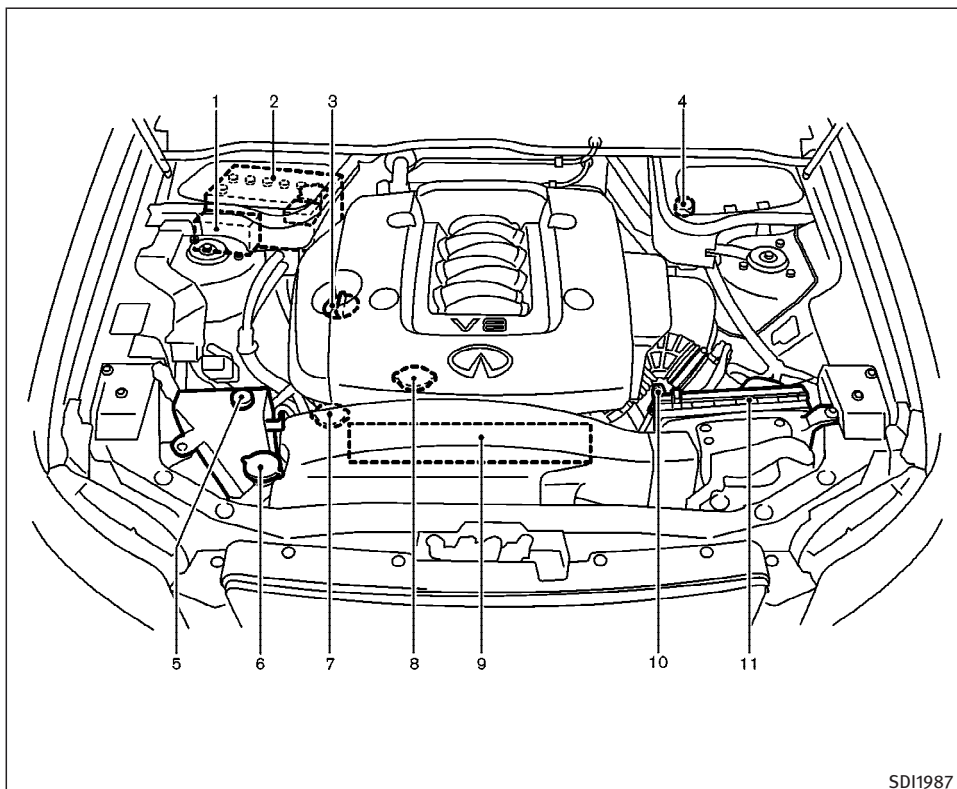

SD11987

## VK45DE ENGINE

1. Fuse/fusible link holder (P.8-24)
2. Battery (P.8-17)
3. Engine oil filler cap (P.8-11)
4. Brake fluid reservoir (P.8-16)
5. Engine coolant reservoir (P.8-9)
6. Window washer fluid reservoir (P.8-16)
7. Power steering fluid reservoir (P.8-15)
8. Radiator filler cap (P.8-9)
9. Drive belts (P.8-19)
10. Engine oil dipstick (P.8-11)
11. Air cleaner (P.8-20)

# 1 Safety – Seats, seat belts and supplemental restraint system

Seats.....	1-2	LATCH (Lower Anchors and Tethers for Children) system .....	1-26
Front power seat adjustment.....	1-2	Top tether strap child restraint.....	1-27
Rear seat adjustment.....	1-4	Child restraint installation on front passenger seat.....	1-29
Head restraint adjustment .....	1-6	Booster seats .....	1-32
Active head restraint (front seats).....	1-7	Precautions on booster seats .....	1-32
Armrest.....	1-7	Booster seat installation on rear seat outboard or center positions.....	1-35
Seat belts.....	1-8	Booster seat installation on front passenger seat.....	1-36
Precautions on seat belt usage .....	1-8	Supplemental restraint system.....	1-37
Child safety.....	1-11	Precautions on supplemental restraint system .....	1-37
Pregnant women .....	1-12	INFINITI advanced air bag system (front seats).....	1-43
Injured persons.....	1-12	Supplemental air bag warning labels.....	1-51
Three-point type seat belt with retractor .....	1-12	Supplemental air bag warning light.....	1-52
Rear center seat belt.....	1-15		
Seat belt extenders.....	1-18		
Seat belt maintenance .....	1-18		
Child restraints .....	1-19		
Precautions on child restraints.....	1-19		
Child restraint installation on rear seat outboard or center positions .....	1-21		

## SEATS

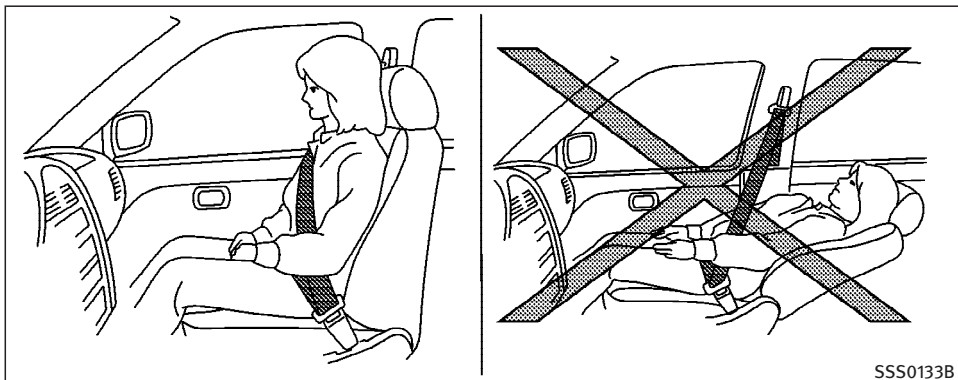

### WARNING

- Do not ride in a moving vehicle when the seatback is reclined. This can be dangerous. The shoulder belt will not be against your body. In an accident, you could be thrown into it and receive neck or other serious injuries. You could also slide under the lap belt and receive serious internal injuries.

- For the most effective protection when the vehicle is in motion, the seat should be upright. Always sit well back in the seat and adjust the seat belt properly. See “Precautions on seat belt usage” later in this section.

## FRONT POWER SEAT ADJUSTMENT



### WARNING

- Do not adjust the driver’s seat while driving so full attention may be given to vehicle operation. The seat may move suddenly and could cause loss of control of the vehicle.
- Do not leave children unattended inside the vehicle. They could unknowingly activate switches or controls. Unattended children could become involved in serious accidents.

### Operating tips

- The seat motor has an auto-reset overload protection circuit. If the motor stops during operation, wait 30 seconds, then reactivate the switch.
- Do not operate the power support seat for a long period of time when the engine is off. This will discharge the battery.

See “Automatic drive positioner” in the “3. Pre-driving checks and adjustments” section for automatic drive positioner operation.

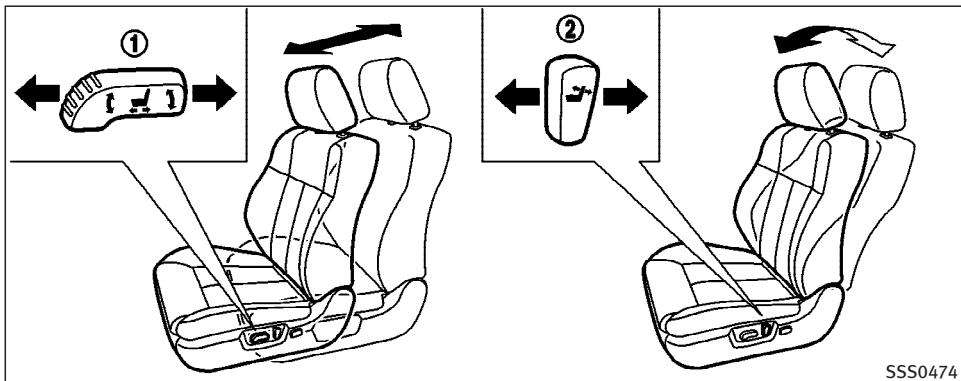

SS50474

### Forward and backward

Moving the switch ① forward or backward will slide the seat forward or backward to the desired position.

### Reclining

Move the recline switch ② backward until the desired angle is obtained. To bring the seatback forward again, move the switch ② forward.

The reclining feature allows adjustment of the seatback for occupants of different sizes for added comfort and to help obtain proper seat belt fit. See “Precautions on seat belt usage” later in this section. The seatback may be reclined to allow occupants to rest when the vehicle is parked.

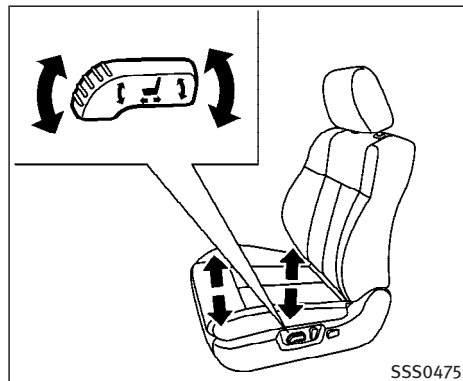

SS50475

### Seat lifter

Push the front or rear end of the switch up or down to adjust the height and angle of the seat.

For the front passenger’s seat, only the angle of the seat can be adjusted.

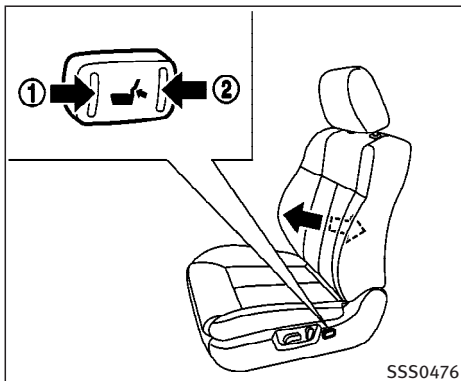

### Lumbar support (if so equipped for driver's seat)

The lumbar support feature provides lower back support to the driver. Push the front ① or back ② end of the switch to adjust the seat lumbar area.

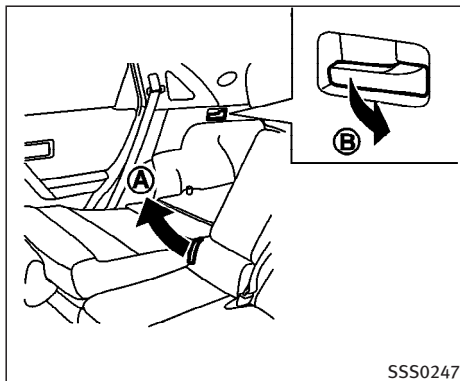

### REAR SEAT ADJUSTMENT

#### Folding

1. Store the center seat belts in the proper position. (See "REAR CENTER SEAT BELT" later in this section.)
2. Slide the front seat forward if necessary. (See "FRONT POWER SEAT ADJUSTMENT" earlier in this section.)
3. Pull the seat belt to side.
4. After removing the tonneau cover (if so equipped), pull the lever on the rear seat ① or pull the lever on both sides of

the luggage room ② and fold the seat-back.

5. When resetting the seat, be sure to install the head restraints.



### WARNING

- Never allow anyone to ride in the cargo area or on the rear seat when it is in the fold-down position. Use of these areas by passengers without proper restraints could result in serious injury in an accident or sudden stop.
- It is extremely dangerous to ride in a cargo area inside a vehicle. In a collision, people riding in these areas are more likely to be seriously injured or killed.
- Do not allow people to ride in any area of your vehicle that is not equipped with seats and seat belts. Be sure everyone in your vehicle is in a seat and using a seat belt properly.
- Do not fold down the rear seats when occupants are in the rear seat area, any

luggage is on the rear seat or any cup is in the cup holder.

- Head restraints should be adjusted properly as they may provide significant protection against injury in an accident. Always replace and adjust them properly if they have been removed for any reason.
- If the head restraints are removed for any reason, they should be securely stored to prevent them from causing injury to passengers or damage to the vehicle in case of sudden braking or an accident.
- Properly secure all cargo to help prevent it from sliding or shifting. Do not place cargo higher than the seatbacks. In a sudden stop or collision, unsecured cargo could cause personal injury.
- When returning the seatbacks to the upright position, be certain they are completely secured in the latched position. If they are not completely secured, passengers may be injured in an accident or sudden stop.

- When returning the seatbacks, be sure to attach the rear center seat belt connector.
- Do not unfasten the rear center seat belt connector except when folding down the rear seat.
- When attaching the rear center seat belt connector, be certain that the seatbacks are completely secured in the latched position and the rear center seat belt connector is completely secured.
- If the rear center seat belt connector and the seatbacks are not secured in the correct position, serious personal injury may result in an accident or sudden stop.

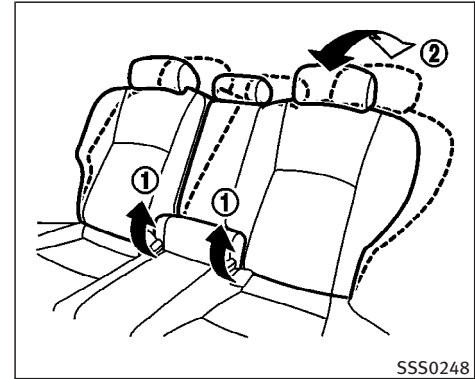

## Reclining

Pull the reclining lever (1) and position the seat back at the desired angle (2). Release the reclining lever (1) after positioning the seat at the desired angle (2).



## WARNING

- Do not ride in a moving vehicle when the seatback is reclined. This can be dangerous. The shoulder belt will not be against your body. In an accident,

you could be thrown into it and receive neck or other serious injuries. You could also slide under the lap belt and receive serious internal injuries.

- For the most effective protection when the vehicle is in motion, the seat should be upright. Always sit well back in the seat and adjust the seat belt properly. See “Precautions on seat belt usage” later in this section.
- After adjustment, gently rock in the seat to make sure it is securely locked.

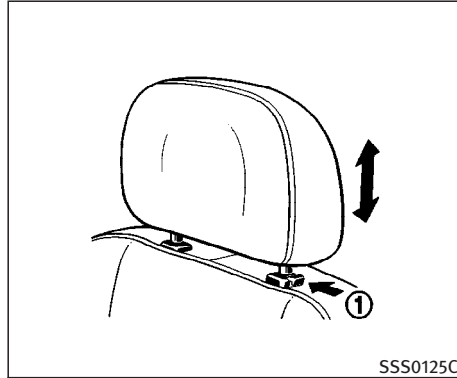

### HEAD RESTRAINT ADJUSTMENT

To raise the head restraint, just pull it up. To lower, push the lock knob ① and push the head restraint down.

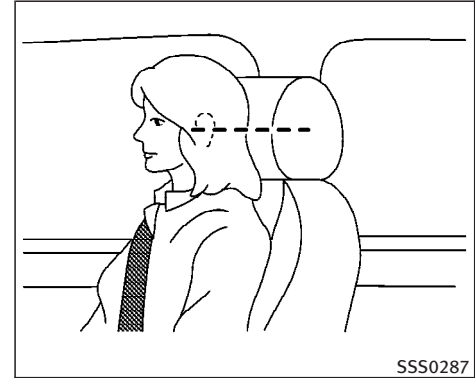

Adjust the head restraints so the center is level with the center of your ears.



### WARNING

Head restraints should be adjusted properly as they may provide significant protection against injury in an accident. Do not remove them. Check the adjustment after someone else uses the seat.



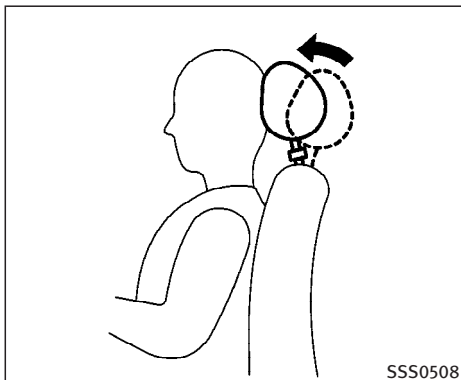

## ACTIVE HEAD RESTRAINT (front seats)



### WARNING

- Always adjust the head restraints properly as specified in the previous section. Failure to do so can reduce the effectiveness of the active head restraint.

- Active head restraints are designed to supplement other safety systems. Always wear seat belts. No system can prevent all injuries in any accident.
- Do not attach anything to the head restraint stalks. Doing so could impair active head restraint function.

The active head restraint moves forward utilizing the force that the seatback receives from the occupant in a rear-end collision. The movement of the head restraint helps support the occupant's head by reducing its backward movement and helping absorb some of the forces that may lead to whiplash type injuries.

Active head restraints are effective for collisions at low to medium speeds in which it is said that whiplash injury occurs most.

Active head restraints operate only in certain rear-end collisions. After the collision, the head restraints return to their original positions.

Properly adjust the active head restraints as described in the previous section.

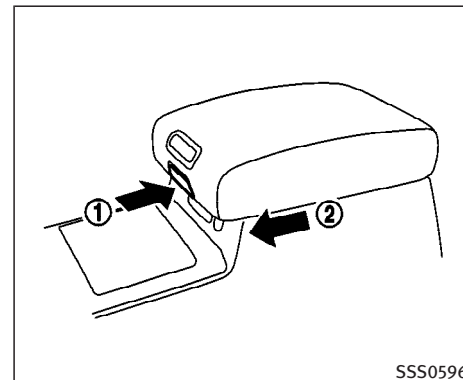

Front

## ARMREST

### Front

Push the button ① while sliding the armrest ② to the desired position.

To use the console box, see “Console box” in the “2. Instruments and controls” section.

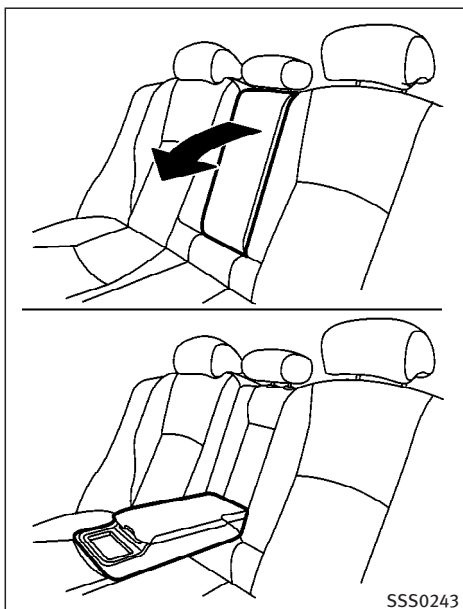

Rear

## Rear

Pull the armrest forward until it is horizontal.

## SEAT BELTS

### PRECAUTIONS ON SEAT BELT USAGE

If you are wearing your seat belt properly adjusted, and you are sitting upright and well back in your seat, your chances of being injured or killed in an accident and/or the severity of injury may be greatly reduced. INFINITI strongly encourages you and all of your passengers to buckle up every time you drive, even if your seating position includes a supplemental air bag.

**Most states, provinces or territories require that seat belts be worn at all times when a vehicle is being driven.**

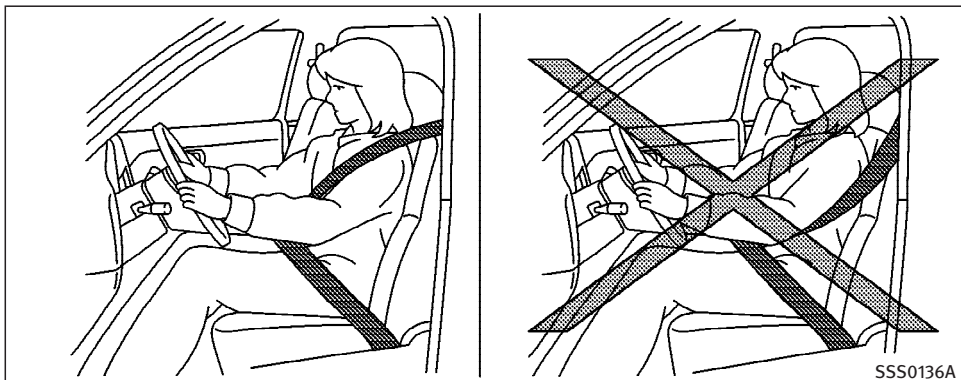

## WARNING

- Every person who drives or rides in this vehicle should use a seat belt at all times. Children should be properly restrained in the rear seat and, if appropriate, in a child restraint.
- The seat belt should be properly adjusted to a snug fit. Failure to do so may reduce the effectiveness of the entire restraint system and increase the chance

or severity of injury in an accident. Serious injury or death can occur if the seat belt is not worn properly.

- Always route the shoulder belt over your shoulder and across your chest. Never run the belt behind your back, under your arm or across your neck. The belt should be away from your face and neck, but not falling off your shoulder.

- Position the lap belt as low and snug as possible **AROUND THE HIPS, NOT THE WAIST**. A lap belt worn too high could increase the risk of internal injuries in an accident.
- Be sure the seat belt tongue is securely fastened to the proper buckle.
- Do not wear the seat belt inside out or twisted. Doing so may reduce its effectiveness.
- Do not allow more than one person to use the same seat belt.
- Never carry more people in the vehicle than there are seat belts.
- If the seat belt warning light glows continuously while the ignition is turned ON with all doors closed and all seat belts fastened, it may indicate a malfunction in the system. Have the system checked by an INFINITI dealer.
- Once the pre-tensioner seat belt has activated, it cannot be reused and must be replaced together with the retractor. See an INFINITI dealer.

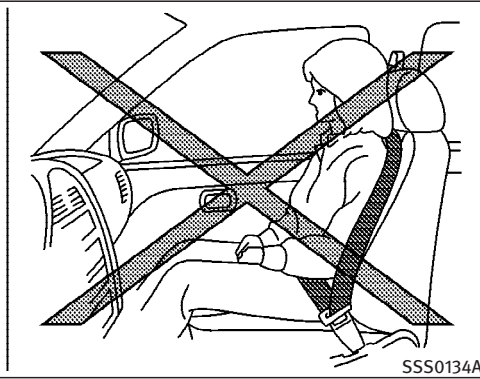
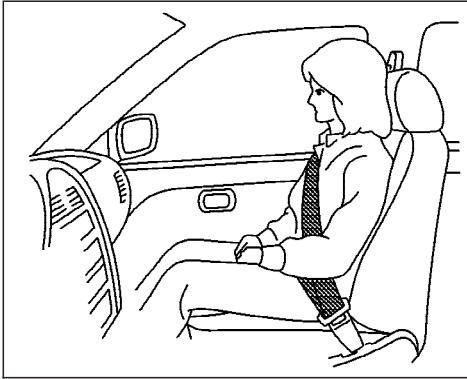

SSS0134A

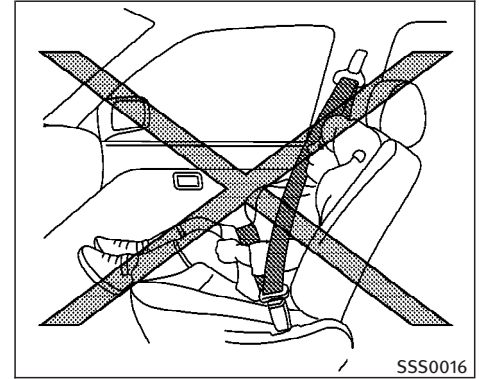

SSS0016

- Removal and installation of the pretensioner seat belt system components should be done by an INFINITI dealer.
- All seat belt assemblies, including retractors and attaching hardware, should be inspected after any collision by an INFINITI dealer. INFINITI recommends that all seat belt assemblies in use during a collision be replaced unless the collision was minor and the belts show no damage and continue to operate properly. Seat belt assemblies not in use during a collision should also be in-

spected and replaced if either damage or improper operation is noted.

- All child restraints and attaching hardware should be inspected after any collision. Always follow the restraint manufacturer's inspection instructions and replacement recommendations. The child restraints should be replaced if they are damaged.

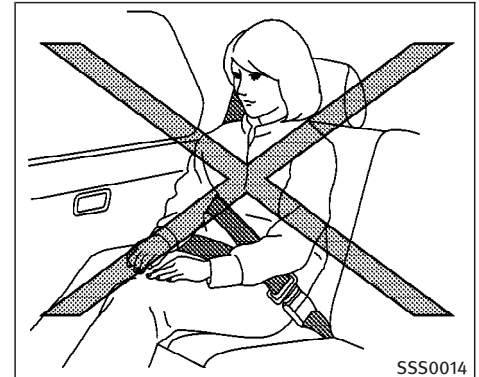

SSS0014

## CHILD SAFETY

**Children need adults to help protect them. They need to be properly restrained.**

In addition to the general information in this manual, child safety information is available from many other sources, including doctors, teachers, government traffic safety offices, and community organizations. Every child is different, so be sure to learn the best way to transport your child.

There are three basic types of child restraint systems:

- Rear facing child restraint
- Front facing child restraint
- Booster seat

The proper restraint depends on the child's size. Generally, infants (up to about 1 year and less than 20 lb (9 kg)) should be placed in rear facing child restraints. Front facing child restraints are available for children who outgrow rear facing child restraints and are at least 1 year old. Booster seats are used to help position a vehicle lap/shoulder belt on a child who can no longer use a front facing child restraint.



### WARNING

**Infants and children need special protection. The vehicle's seat belts may not fit them properly. The shoulder belt may come too close to the face or neck. The lap belt may not fit over their small hip bones. In an accident, an improperly fitting seat belt could cause serious or fatal injury. Always use appropriate child restraints.**

All U.S. states and Canadian provinces or territories require the use of approved child restraints for infants and small children. (See "Child restraints" later in this section.)

Also, there are other types of child restraints available for larger children for additional protection.

**INFINITI recommends that all pre-teens and children be restrained in the rear seat. According to accident statistics, children are safer when properly restrained in the rear seat than in the front seat.**

**This is especially important because your vehicle has a supplemental restraint**

**system (air bag system) for the front passenger. See "Supplemental restraint system" later in this section.**

### Infants

Infants up to at least one year old should be placed in a rear facing child restraint. INFINITI recommends that infants be placed in child restraints that comply with Federal Motor Vehicle Safety Standards or Canadian Motor Vehicle Safety Standards. You should choose a child restraint which fits your vehicle and always follow the manufacturer's instructions for installation and use.

### Small children

Children that are over one year old and weigh between 20 lb (9 kg) and 40 lb (18 kg) can be placed in a forward facing child restraint. Refer to the manufacturer's instructions for minimum and maximum weight and height recommendations. INFINITI recommends that small children be placed in child restraints that comply with Federal Motor Vehicle Safety Standards or Canadian Motor Vehicle Safety Standards. You should choose a child restraint that fits your vehicle and always follow the manufacturer's instructions for installation and use.

## Larger children

Children who are too large for child restraints should be seated and restrained by the seat belts which are provided. The seat belt may not fit properly if the child is less than 4 feet 9 inches (142.5 cm) tall and weighs between 40 lb (18 kg) and 80 lb (36 kg). A booster seat should be used to obtain proper seat belt fit.

INFINITI recommends that a child be placed in a commercially available booster seat if the shoulder belt in the child's seating position fits close to the face or neck or if the lap portion of the seat belt goes across the abdomen. The booster seat should raise the child so that the shoulder belt is properly positioned across the top, middle portion of the shoulder and the lap belt is low on the hips. A booster seat can only be used in seating positions that have a three-point type seat belt. The booster seat should fit the vehicle seat and have a label certifying that it complies with Federal Motor Vehicle Safety Standards or Canadian Motor Vehicle Safety Standards. Once the child has grown so the shoulder belt is no longer on or near the face and neck, use the shoulder belt without the booster seat.



## WARNING

**Never let a child stand or kneel on any seat and do not allow a child in the cargo areas while the vehicle is moving. The child could be seriously injured or killed in an accident or sudden stop.**

## PREGNANT WOMEN

INFINITI recommends that pregnant women use seat belts. The seat belt should be worn snug, and always position the lap belt as low as possible around the hips, not the waist, and place the shoulder belt over your shoulder and across your chest. Never run the lap/shoulder belt over your abdominal area. Contact your doctor for specific recommendations.

## INJURED PERSONS

INFINITI recommends that injured persons use seat belts, depending on the injury. Check with your doctor for specific recommendations.

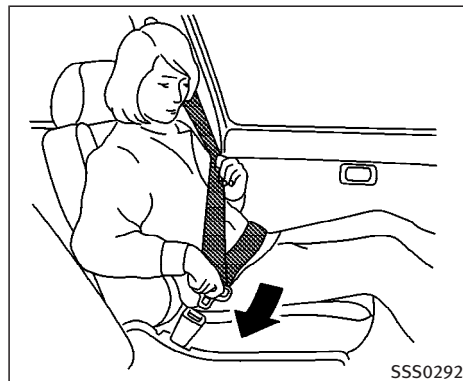

## Front seat THREE-POINT TYPE SEAT BELT WITH RETRACTOR



## WARNING

- Every person who drives or rides in this vehicle should use a seat belt at all times.
- Do not ride in a moving vehicle when the seatback is reclined. This can be dangerous. The shoulder belt will not be against your body. In an accident,



Rear seat

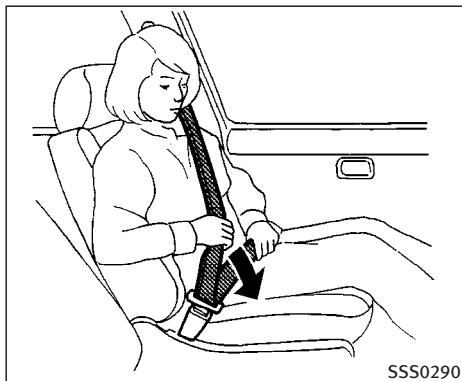

Front seat

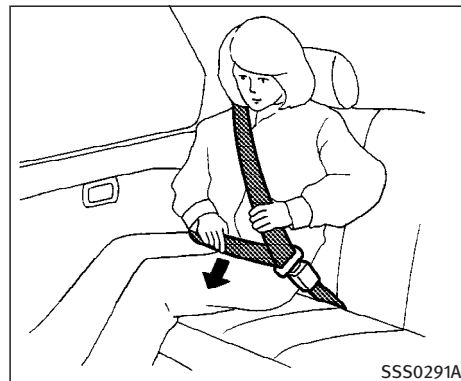

Rear seat

you could be thrown into it and receive neck or other serious injuries. You could also slide under the lap belt and receive serious internal injuries.

- For the most effective protection when the vehicle is in motion, the seat should be upright. Always sit well back in the seat and adjust the seat belt properly.

### Fastening the seat belts

1. Adjust the seat. See “Seats” earlier in this section.
2. Slowly pull the seat belt out of the retractor and insert the tongue into the buckle until it clicks. (For additional information regarding the rear center seat belt, see “Setting center seat belt”.)
- **The retractor is designed to lock during a sudden stop or on impact. A slow pulling motion will permit the belt to move, and allow you some freedom of movement in the seat.**

- **If the seat belt cannot be pulled from its fully retracted position, firmly pull the belt and release it. Then smoothly pull the belt out of the retractor.**
- 3. Position the lap belt portion **low and snug on the hips** as shown.
- 4. Pull the shoulder belt portion toward the retractor to take up extra slack. Be sure the shoulder belt is routed over your shoulder and across your chest.

The front passenger and rear seat belts have a locking mechanism for child re-

straint installation. It is referred to as the automatic locking mode.

When the locking mechanism is activated the seat belt cannot be extended again until the seat belt tongue is detached from the buckle and fully retracted. For additional information, see “Child restraints” later in this section.

**The automatic locking mode should be used only for child restraint installation. During normal seat belt use by a passenger, the locking mode should not be activated. If it is activated it may cause uncomfortable seat belt tension. It can also change the operation of the front passenger air bag. See “Front passenger air bag and status light” later in this section.**



## WARNING

When fastening the seat belts, be certain that the seatbacks are completely secured in the latched position. If they are not completely secured, passengers may be injured in an accident or sudden stop.

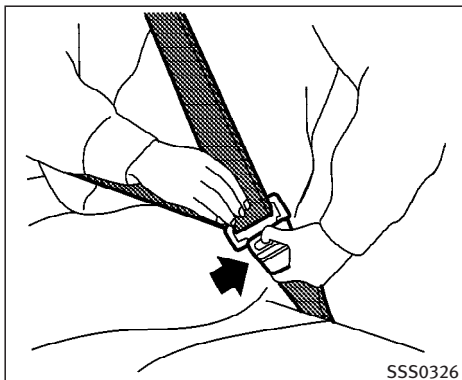

To increase your confidence in the seat belts, check the operation as follows:

- grasp the shoulder belt and pull quickly forward. The retractor should lock and restrict further belt movement.

If the retractor does not lock during this check or if you have any questions about belt operation, see an INFINITI dealer.

## Unfastening the seat belts

To unfasten the belt, press the button on the buckle. The seat belt will automatically retract.

## Checking seat belt operation

Your seat belt retractors are designed to lock belt movement using two separate methods:

- when the belt is pulled quickly from the retractor.
- when the vehicle slows down rapidly.



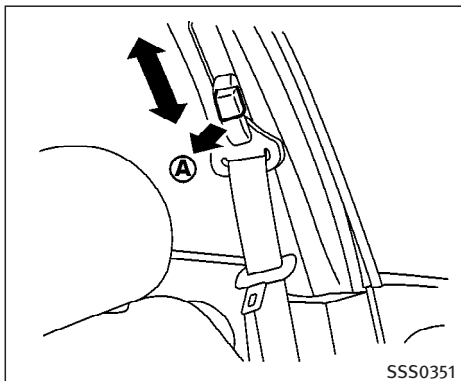

### Shoulder belt height adjustment (for front seats)

The shoulder belt anchor height should be adjusted to the position best suited for you. (See “Precautions on seat belt usage” earlier in this section.) To adjust, pull the release button (A), and then move the shoulder belt anchor to the desired position, so that the belt passes over the center of the shoulder. The belt should be away from your face and neck, but not falling off of your shoulder. Release the adjustment button to lock the shoulder belt anchor into position.

### WARNING

- After adjustment, release the adjustment button and try to move the shoulder belt anchor up and down to make sure it is securely fixed in position.
- The shoulder belt anchor height should be adjusted to the position best for you. Failure to do so may reduce the effectiveness of the entire restraint system and increase the chance or severity of injury in an accident.

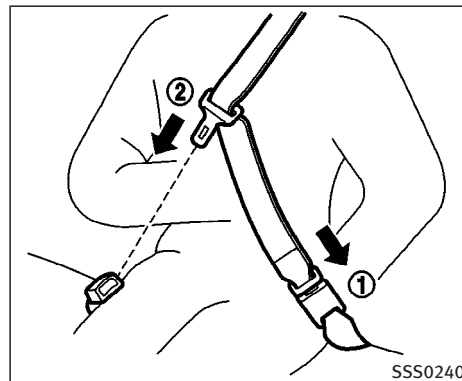

### REAR CENTER SEAT BELT

The rear center seat belt has a connector tongue (1) and a seat belt tongue (2). Both the connector tongue and the seat belt tongue must be securely latched for proper seat belt operation.

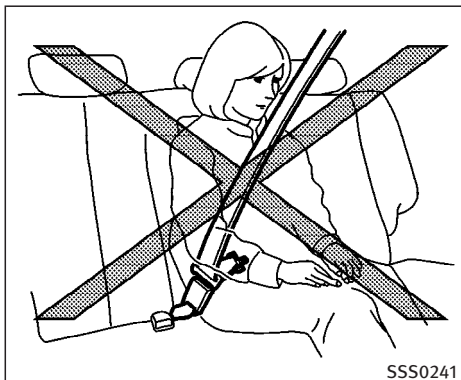

## WARNING

- Always fasten the connector tongue and the seat belt in the order shown.
- Always make sure both the connector tongue and the seat belt tongue are secured when using the seat belt. Do not use it with only the seat belt tongue attached. This could result in serious personal injury in case of an accident or a sudden stop.

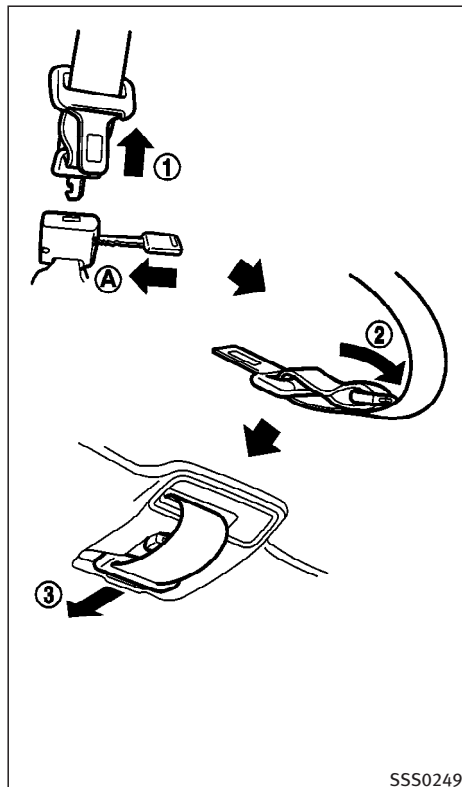

## Stowing rear center seat belt

When folding down the rear seat, the rear center seat belt can be retracted into a stowed position as follows:

1. Hold the connector tongue (1) so that the seat belt does not retract suddenly when the tongue is released from the connector buckle.
2. Insert a suitable tool such as a key (A) into the connector buckle and release the connector tongue.
3. Fold the connector as illustrated (2).
4. Then secure the connector tongue into the retractor base (3) in the ceiling.

## WARNING

- Do not unfasten the rear center seat belt connector except when folding down the rear seat.
- When attaching the rear center seat belt connector, be certain that the seatbacks are completely secured in the latched position and the rear center seat belt connector is completely secured.

- If the rear center seat belt connector and the seatbacks are not secured in the correct position, serious personal injury may result in an accident or sudden stop.

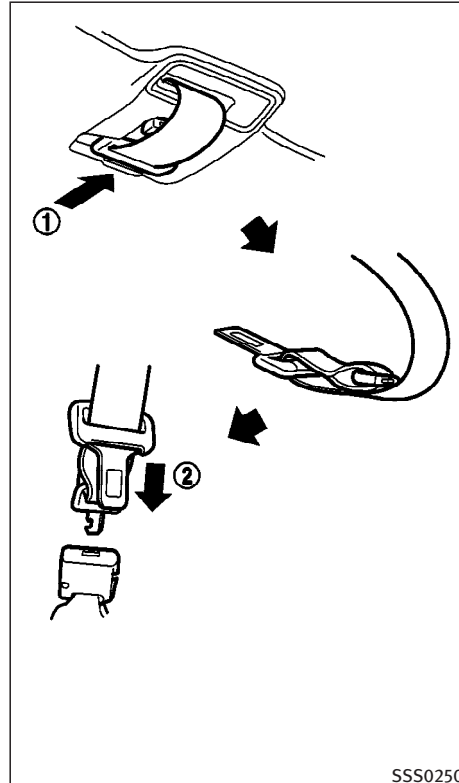

## Attaching rear center seat belt

Always be sure the rear center seat belt connector tongue and connector buckle are attached. Disconnect only when folding down the rear seat.

To connect the buckle:

1. Pull out the seat belt tongue from the retractor base (1) in the ceiling.
2. Pull the seat belt and secure the connector buckle until it clicks (2).

The center seat belt connector tongue and buckle are indicated by the “▼” and “▲” mark.

The center seat belt connector tongue can be attached only into the rear center seat belt connector buckle.

To fasten the seat belt, see “Fastening the seat belt” earlier in this section.



### WARNING

- Do not unfasten the rear center seat belt connector except when folding down the rear seat.

- When attaching the rear center seat belt connector, be certain that the seatbacks are completely secured in the latched position and the rear center seat belt connector is completely secured.
- If the rear center seat belt connector and the seatbacks are not secured in the correct position, serious personal injury may result in an accident or sudden stop.

## SEAT BELT EXTENDERS

If, because of body size or driving position, it is not possible to properly fit the lap-shoulder belt and fasten it, an extender is available. The extender adds approximately 8 inches (200 mm) of length and may be used for either the driver or front passenger seating position. See an INFINITI dealer for assistance if the extender is required.



## WARNING

- Only INFINITI seat belt extenders, made by the same company which made the original equipment seat belts, should be used with INFINITI seat belts.
- Adults and children who can use the standard seat belt should not use an extender. Such unnecessary use could result in serious personal injury in the event of an accident.
- Never use seat belt extenders to install child restraints. If the child restraint is not secured properly, the child could be seriously injured in a collision or a sudden stop.

## SEAT BELT MAINTENANCE

- To clean the seat belt webbings, apply a mild soap solution or any solution recommended for cleaning upholstery or carpets. Then brush the webbing, wipe it with a cloth and allow it to dry in the shade. Do not allow the seat belts to retract until they are completely dry.

- If dirt builds up in the shoulder belt guide of the seat belt anchors, the seat belts may retract slowly. Wipe the shoulder belt guide with a clean, dry cloth.
- Periodically check to see that the seat belt and the metal components such as buckles, tongues, retractors, flexible wires and anchors work properly. If loose parts, deterioration, cuts or other damage on the webbing is found, the entire belt assembly should be replaced.

## CHILD RESTRAINTS

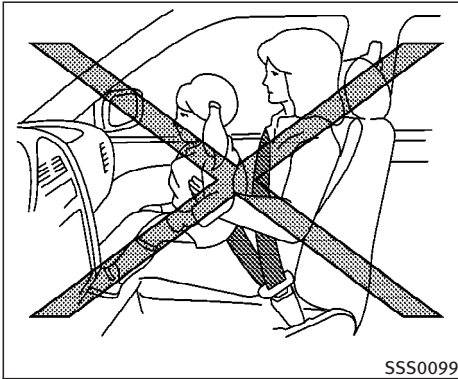

### PRECAUTIONS ON CHILD RESTRAINTS



#### WARNING

- Infants and small children should always be placed in an appropriate child restraint while riding in the vehicle. Failure to use a child restraint can result in serious injury or death.
- Infants and small children should never be carried on your lap. It is not possible

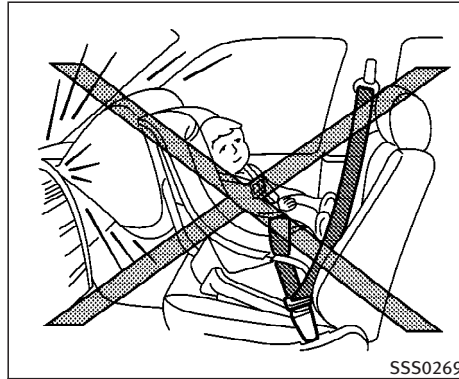

- for even the strongest adult to resist the forces of a severe accident. The child could be crushed between the adult and parts of the vehicle. Also, do not put the same seat belt around both your child and yourself.
- Never install a rear-facing child restraint in the front seat. An inflating supplemental front air bag could seriously injure or kill your child. A rear-facing child restraint must only be used in the rear seat.

- INFINITI recommends that the child restraint be installed in the rear seat. According to accident statistics, children are safer when properly restrained in the rear seat than in the front seat.
- An improperly installed child restraint could lead to serious injury or death in an accident.

In general, child restraints are designed to be installed with the lap/shoulder seat belt. In addition, this vehicle is equipped with a universal child restraint lower anchor system, referred to as the LATCH (Lower Anchors and Tethers for Children) system. Some child restraints include two rigid or webbing-mounted attachments that can be connected to these lower anchors. For details, see “LATCH (Lower Anchors and Tethers for Children) SYSTEM” later in this section.

Child restraints for infants and children of various sizes are offered by several manufacturers. When selecting any child restraint, keep the following points in mind:

- choose only a restraint with a label certifying that it complies with Federal Motor Vehicle Safety Standard 213 or

Canadian Motor Vehicle Safety Standard 213.

- check the child restraint in your vehicle to be sure it is compatible with the vehicle's seat and seat belt system.
- if the child restraint is compatible with your vehicle, place your child in the child restraint and check the various adjustments to be sure the child restraint is compatible with your child. Choose a child restraint that is designed for your child's height and weight. Always follow all recommended procedures.

**All U.S. states and Canadian provinces require that infants and small children be restrained in approved child restraints at all times while the vehicle is being operated.**



## **WARNING**

- Improper use of a child restraint can increase the risk or severity of injury for both the child and other occupants of the vehicle.

- Follow all of the child restraint manufacturer's instructions for installation and use. When purchasing a child restraint, be sure to select one which will fit your child and vehicle. It may not be possible to properly install some types of child restraints in your vehicle.
- If the child restraint is not anchored properly, the risk of a child being injured in a collision or a sudden stop greatly increases.
- Adjustable seatbacks should be positioned to fit the child restraint, but as upright as possible.
- After attaching the child restraint, test it before you place the child in it. Push it from side to side. Try to tug it forward and check to see if the belt holds the restraint in place. The child restraint should not move more than 1 inch (25 mm). If the restraint is not secure, tighten the belt as necessary, or put the restraint in another seat and test it again. You may need to try a different child restraint. Not all child restraints fit in all types of vehicles.

- If you must install a front facing child restraint in the front seat, see "Child restraint installation on front passenger seat" later in this section for details.
- When your child restraint is not in use, keep it secured with a seat belt to prevent it from being thrown around in case of a sudden stop or accident.



## **CAUTION**

Remember that a child restraint left in a closed vehicle can become very hot. Check the seating surface and buckles before placing your child in the child restraint.

## CHILD RESTRAINT INSTALLATION ON REAR SEAT OUTBOARD OR CENTER POSITIONS

### **WARNING**

- The three-point seat belt in your vehicle is equipped with an automatic locking mode retractor which must be used when installing a child restraint.
- Failure to use the automatic locking mode will result in the child restraint not being properly secured. The restraint could tip over or otherwise be unsecured and cause injury to the child in a sudden stop or collision.
- When installing a child restraint system in the rear center position both the center seat belt connector tongue and buckle tongue must be secured. See “Attaching rear center seat belt” earlier in this section.

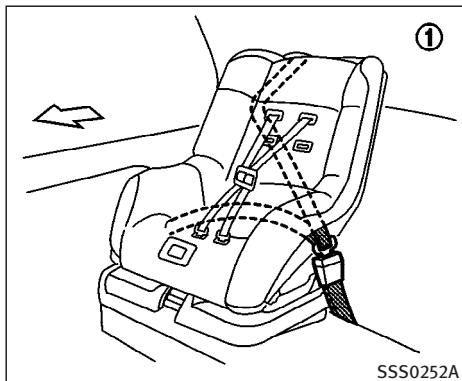

**Rear outboard seat**

### Front facing

When you install a child restraint in a rear outboard or center seat, follow these steps:

1. Position the child restraint on the seat. Always follow the child restraint manufacturer’s instructions. The back of the child restraint should be secured against the vehicle seatback. If necessary, adjust or remove the head restraint to obtain the correct child restraint fit. See “Head restraint adjustment” earlier in this section. If the head restraint is removed, store it in a

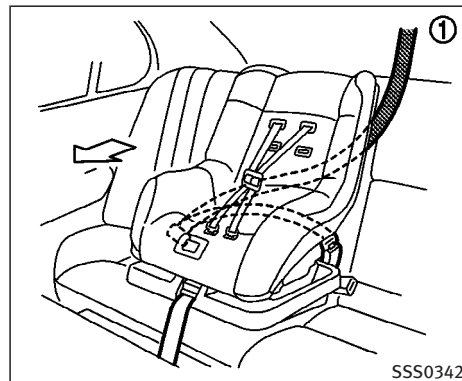

**Rear center seat**

secure place. Be sure to install the head restraint when the child restraint is removed. If the seating position does not have an adjustable head restraint and it is interfering with the proper child restraint fit, try another seating position or a different child restraint.

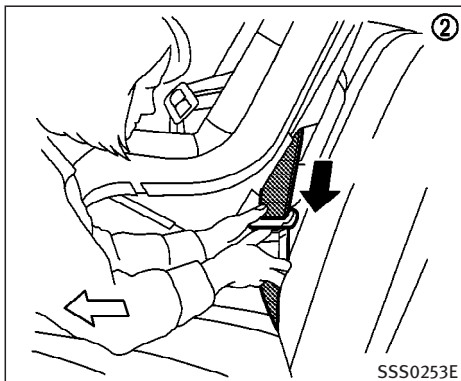

2. Route the seat belt tongue through the child restraint and insert it into the buckle until you hear and feel the latch engage. Be sure to follow the child restraint manufacturer's instructions for belt routing.

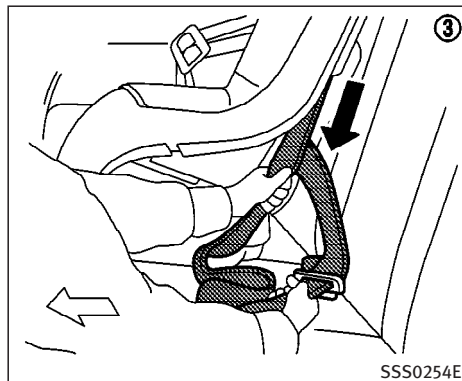

3. Pull on the shoulder belt until all of the belt is fully extended. At this time, the belt retractor is in the automatic locking mode (child restraint mode). It reverts back to emergency locking mode when the belt is fully retracted.

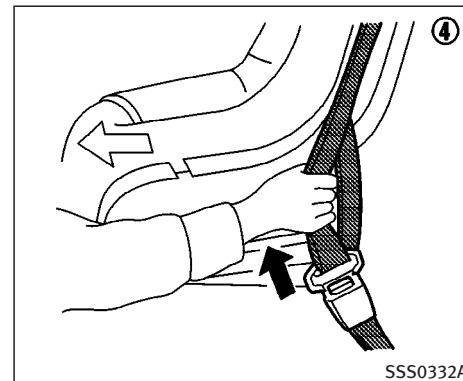

4. Allow the seat belt to retract. Pull up on the shoulder belt to remove any slack in the belt.



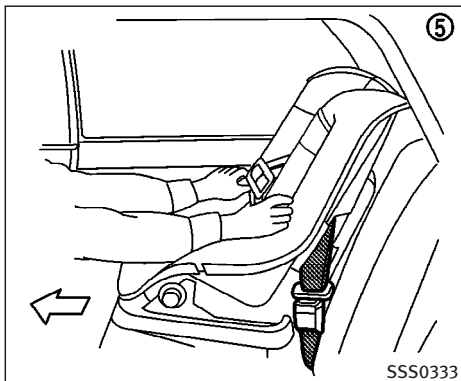

5. Before placing the child in the child restraint, use force to push the child restraint from side to side, and push it forward to make sure that it is securely held in place. It should not move more than 1 inch (25 mm). If it does move more than 1 inch (25 mm), pull again on the shoulder belt to further tighten the child restraint. If unable to properly secure the restraint, move the restraint to another rear seating position and try again, or try a different child restraint. Not all child restraints fit in all types of vehicles.

6. Check that the retractor is in the automatic locking mode by trying to pull more belt out of the retractor. If you cannot pull any more belt webbing out of the retractor, the belt is in the automatic locking mode.
7. Check to make sure that the child restraint is properly secured prior to each use. If the belt is not locked, repeat steps 3 through 6.

After the child restraint is removed and the seat belt is fully retracted, the automatic locking mode (child restraint mode) will be canceled.

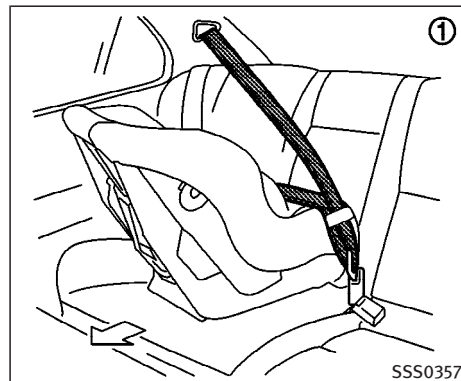

#### Rear outboard seat

#### Rear facing

When you install a child restraint in a rear outboard or center seat, follow these steps:

1. Position the child restraint on the seat. Always follow the restraint manufacturer's instructions.

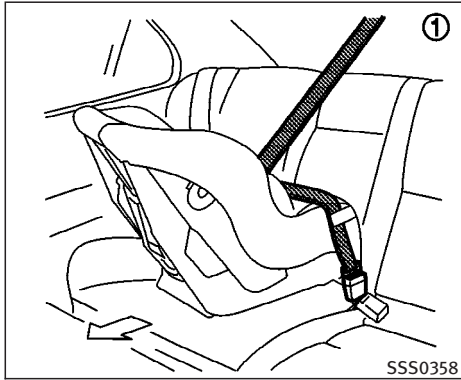

Rear center seat

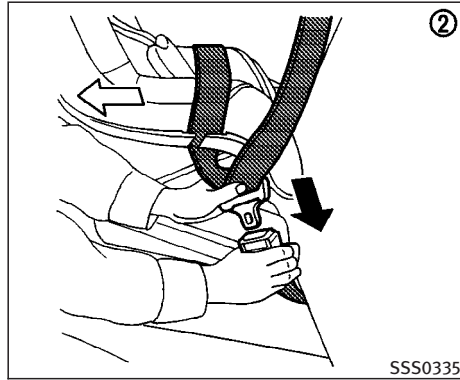

2. Route the seat belt tongue through the child restraint and insert it into the buckle until you hear and feel the latch engage. Be sure to follow the child restraint manufacturer's instructions for belt routing.

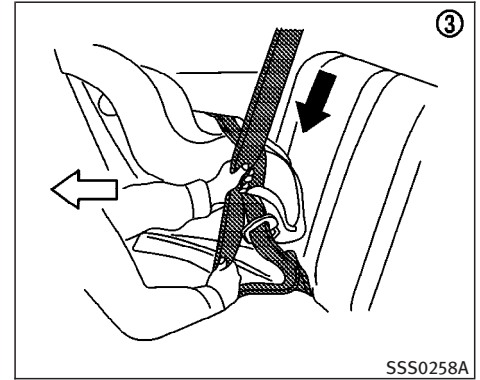

3. Pull on the shoulder belt until all of the belt is fully extended. At this time, the belt retractor is in the automatic locking mode (child restraint mode). It reverts back to emergency locking mode when the belt is fully retracted.

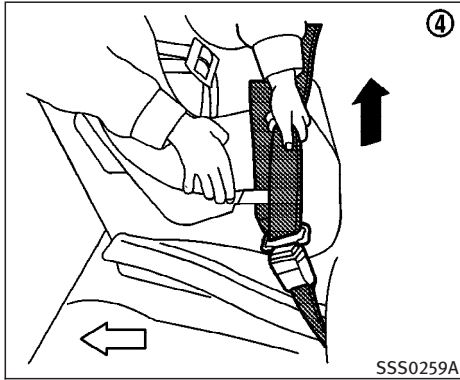

4. Allow the seat belt to retract. Pull up the shoulder belt to remove any slack in the belt.

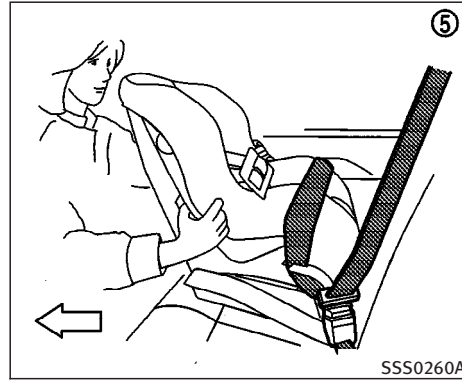

5. Before placing the child in the child restraint, use force to push the child restraint from side to side, and tug it forward to make sure that it is securely held in place. It should not move more than 1 inch (25 mm). If it does move more than 1 inch (25 mm), pull again on the shoulder belt to further tighten the child restraint. If unable to properly secure the restraint, move the restraint to another rear seating position and try again, or try a different child restraint. Not all child restraints fit in all types of vehicles.

6. Check that the retractor is in the automatic locking mode by trying to pull more belt out of the retractor. If you cannot pull any more belt webbing out of the retractor, the belt is in the automatic locking mode.
7. Check to make sure that the child restraint is properly secured prior to each use. If the belt is not locked, repeat steps 3 through 6.

After the child restraint is removed and the seat belt is allowed to wind back into the retractor, the automatic locking mode (child restraint mode) is canceled.

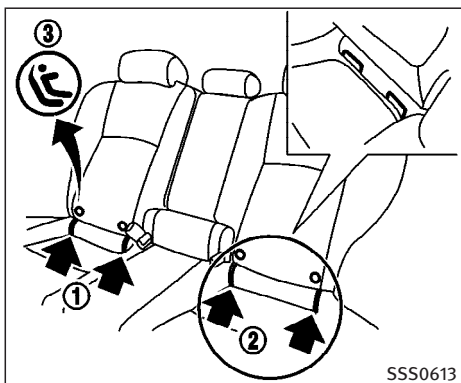

## LATCH (LOWER ANCHORS AND TETHERS FOR CHILDREN) SYSTEM

- ① LATCH lower anchor points (right)
- ② LATCH lower anchor points (left)
- ③ LATCH label

The LATCH (Lower Anchors and Tethers for Children) anchor points are located in the seat cushions of the rear outboard seating positions only. Do not attempt to install a child restraint in the center position using the LATCH anchors.

The LATCH system anchors are located at the rear of the seat cushion near the seat-

back. A label is attached to the seatback to help you locate the LATCH system anchors.

### **WARNING**

- **Attach LATCH system compatible child restraints only at the locations shown. If a child restraint is not secured properly, your child could be seriously injured or killed in an accident.**
- **Do not secure a child restraint in the rear center seating position using the LATCH system anchors. The child restraint will not be secured properly.**
- **The LATCH system anchors are designed to withstand only those loads imposed by correctly fitted child restraints. Under no circumstance are they to be used for adult seat belts or harnesses.**

Some child restraints include two rigid or webbing-mounted attachments that can be connected to two anchors located at certain seating positions in your vehicle. This system is known as the LATCH system. This system may also be referred to as the ISOFIX or ISOFIX compatible system. With

this system, you do not have to use a vehicle seat belt to secure the child restraint. Your vehicle is equipped with special anchor points that are used with LATCH system compatible child restraints. Check your child restraint for a label stating that it is compatible with the LATCH system. This information may also be in the instructions provided by the child restraint manufacturer. If you have such a child restraint, refer to the illustration for the rear seating positions equipped with LATCH system anchors which can be used to secure the child restraint.

Some child restraints may also require the use of a top tether strap. See “Top tether strap child restraint” later in this section for installation instructions.

When installing a child restraint, carefully read and follow the instructions in this manual and those supplied with the child restraint.

When you install a LATCH system compatible child restraint to the lower anchor attachments in the rear seat, follow these steps.



## WARNING

Inspect the lower anchors by inserting your fingers into the lower anchor area and feeling to make sure there are no obstructions over the LATCH system anchors, such as seat belt webbing or seat cushion material. The child restraint will not be secured properly if the LATCH system anchors are obstructed.

1. To install the LATCH system compatible child restraint, insert the child restraint LATCH system anchor attachments into the anchor points on the seat.

To assist in attaching the child restraint to the lower anchors, recline the seatback, latch the anchor attachments to the anchors, and then return the seatback to its normal, locked position. If the child restraint is equipped with a top tether, see “Top tether strap child restraint” later in this section for installation instructions.

2. After attaching the child restraint and before placing the child in it, use force to push the child restraint from side to

side and tug it forward to make sure that the child restraint is securely held in place. It should not move more than 1 inch (25 mm).

3. Check to make sure that the child restraint is properly secured prior to each use.

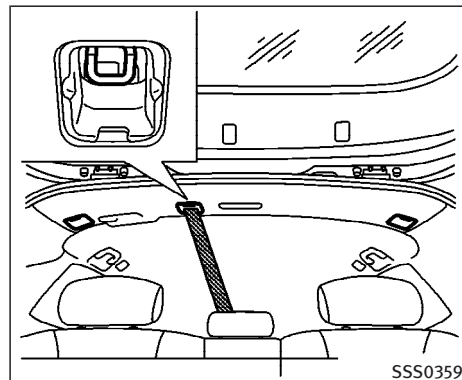

## TOP TETHER STRAP CHILD RESTRAINT



## WARNING

- Child restraint anchor points are designed to withstand only those loads imposed by correctly fitted child restraints. Under no circumstances are they to be used for adult seat belts or harnesses.

- **After removing a rear seat head restraint for top tether installation, store it securely to prevent it from causing injury to passengers or damage to the vehicle in case of sudden braking or an accident. Always replace it and adjust properly when top tether is no longer in use.**

If your child restraint has a top tether strap, it must be secured to the anchor point provided behind its position.

First, adjust the seatback so that it is upright. Then secure the child restraint with the rear seat belt or the LATCH system (outboard positions), as applicable. Remove the anchor cover from the anchor point as illustrated. Keep the removed cover in a secure place to prevent loss or damage.

Remove the head restraint from the seatback. Store it in a secure place. Position the top tether strap over the top of the seatback and secure it to the tether anchor bracket that provides the straightest installation. Tighten the tether strap according to the manufacturer's instruction to remove any slack.

For best child restraint fit, see the child restraint installation instructions in this section and the child restraint manufacturer's instructions.

### Anchor point locations

Anchor points are located on the ceiling above the luggage room.

**If you have any questions when installing a top strap child restraint on the rear seat, consult an INFINITI dealer for details.**

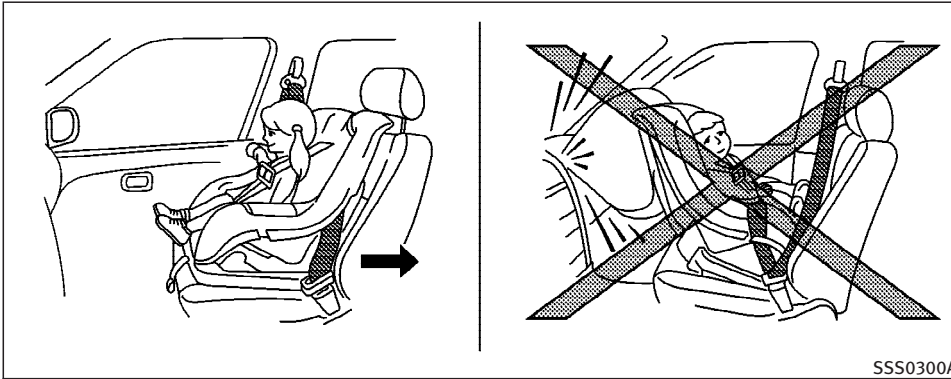

SSS0300A

## CHILD RESTRAINT INSTALLATION ON FRONT PASSENGER SEAT



### WARNING

- Never install a rear-facing child restraint in the front passenger seat. Supplemental front air bags inflate with great force. A rear-facing child restraint could be struck by the supplemental front air bag in a crash and could seriously injure or kill your child.

- INFINITI recommends that child restraints be installed in the rear seat. However, if you must install a forward-facing child restraint in the front passenger seat, move the passenger seat to the rearmost position. Also, be sure the front passenger air bag status light is illuminated to indicate the passenger air bag is OFF. See “Front passenger air bag and status light” later in this section for details.

- A child restraint with a top tether strap should not be used in the front passenger seat.
- The passenger three-point seat belt is equipped with an automatic locking mode retractor which must be used when installing a child restraint.
- Failure to use the automatic locking mode will result in the child restraint not being properly secured. The restraint could tip over or otherwise be unsecured and cause injury to the child in a sudden stop or collision. Also, it can change the operation of the front passenger air bag. See “Front passenger air bag and status light” later in this section.

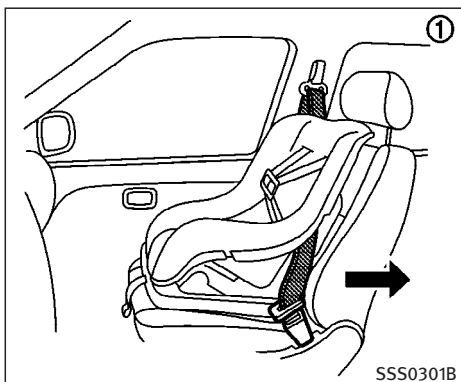

The back of the child restraint should be secured against the vehicle seatback. If necessary, adjust or remove the head restraint to obtain the correct child restraint fit. See “Head restraint adjustment” earlier in this section. If the head restraint is removed, store it in a secure place. Be sure to install the head restraint when the child restraint is removed. If the seating position does not have an adjustable head restraint and it is interfering with the proper child restraint fit, try another seating position or a different child restraint.

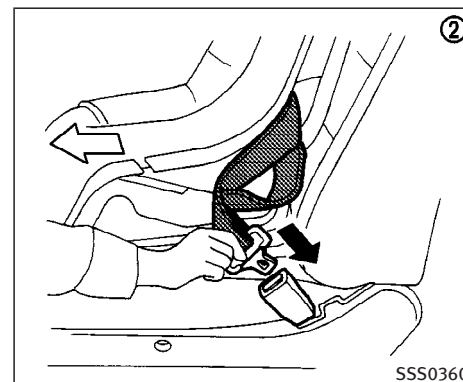

## Front facing

If you must install a child restraint in the front seat, follow these steps:

1. Position the child restraint on the front passenger seat. **It should be placed in a front facing direction only.** Move the seat to the rearmost position. Adjust the head restraint to its highest position. Always follow the child restraint manufacturer’s instructions. **Child restraints for infants must be used in the rear facing direction and therefore must not be used in the front seat.**

2. Route the seat belt tongue through the child restraint and insert it into the buckle until you hear and feel the latch engage. Be sure to follow the child restraint manufacturer’s instructions for belt routing.



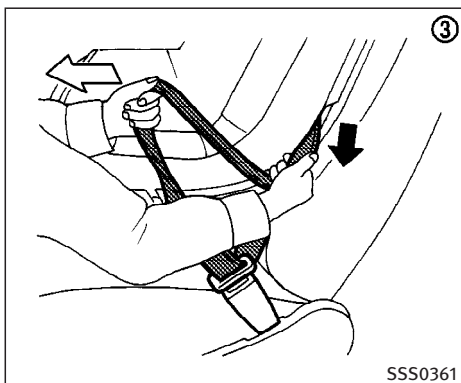

3. Pull on the shoulder belt until all of the belt is fully extended. At this time, the belt retractor is in the automatic locking mode (child restraint mode). It reverts back to emergency locking mode when the belt is fully retracted.

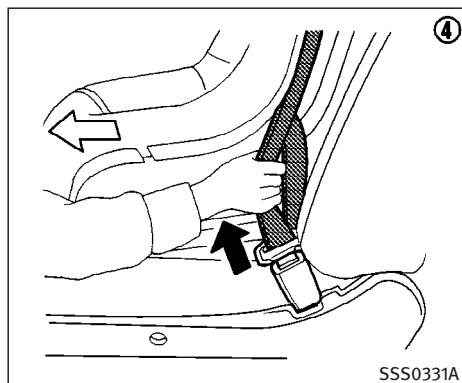

4. Allow the seat belt to retract. Pull up on the shoulder belt to remove any slack in the belt.

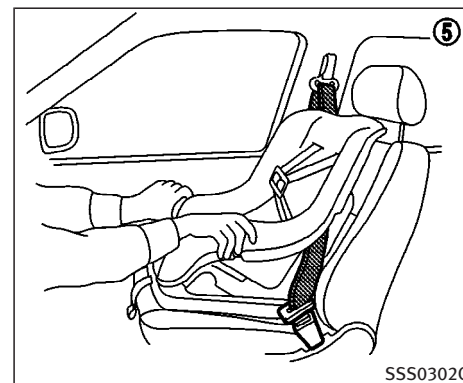

5. Before placing the child in the child restraint, use force to push the child restraint from side to side, and tug it forward to make sure that it is securely held in place. It should not move more than 1 inch (25 mm). Before placing the child in the child restraint, use force to tilt the child restraint from side to side, and tug it forward to make sure that it is securely held in place. It should not move more than 1 inch (25 mm). If it does move more than 1 inch (25 mm), pull again on the shoulder belt to further tighten the child restraint. If un-

able to properly secure the restraint, move the restraint to another rear seating position and try again, or try a different child restraint. Not all child restraints fit in all types of vehicles.

6. Check that the retractor is in the automatic locking mode by trying to pull more belt out of the retractor. If you cannot pull any more belt webbing out of the retractor, the belt is in the automatic locking mode.
7. Check to make sure that the child restraint is properly secured prior to each use. If the lap belt is not locked, repeat steps 3 through 6.
8. Turn the ignition switch to the ON position. The passenger air bag status light  should illuminate. If this light is not illuminated, see “Front passenger air bag and status light” later in this section. **Move the child restraint to another seating position.** Have the system checked by an INFINITI dealer.

After the child restraint is removed and the seat belt is fully retracted, the automatic locking mode (child restraint mode) will be canceled.

## BOOSTER SEATS

### PRECAUTIONS ON BOOSTER SEATS



#### WARNING

- Infants and small children should always be placed in an appropriate child restraint or booster seat while riding in the vehicle. Failure to use a child restraint or booster seat can result in serious injury or death.
- Infants and small children should never be carried on your lap. It is not possible for even the strongest adult to resist the forces of a severe accident. The child could be crushed between the adult and parts of the vehicle. Also, do not put the same seat belt around both your child and yourself.
- INFINITI recommends that the booster seat be installed in the rear seat. According to accident statistics, children are safer when properly restrained in the rear seat than in the front seat.

- A booster seat must only be installed in a seating position that has a lap/shoulder seat belt with a booster seat can result in a serious injury in sudden stop or collision.
- An improperly installed booster seat could lead to serious injury or death in an accident.

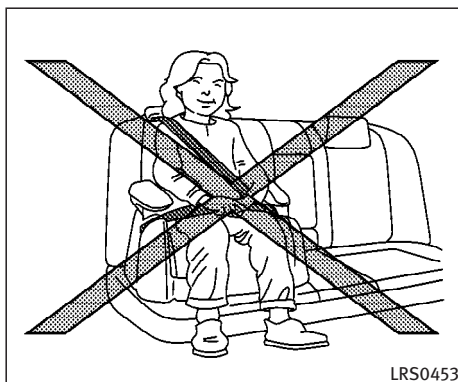
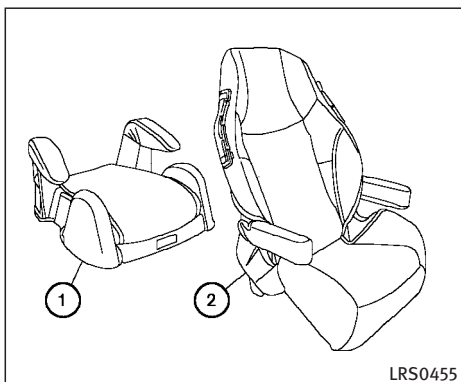

## WARNING

Do not use towels, books, pillows or other items in place of a booster seat. Items such as these may move during normal driving or a collision and result in serious injury or death. Booster seats are designed to be used with a lap/shoulder belt. Booster seats are designed to properly route the lap and shoulder portions of the seat belt over the strongest portions of a child's body to pro-

vide the maximum protection during a collision.

Booster seats of various sizes are offered by several manufacturers. When selecting any booster seat, keep the following points in mind:

- Choose only a booster seat with a label certifying that it complies with Federal Motor Vehicle Safety Standard 213 or Canadian Motor Vehicle Safety Standard 213.

- Check the booster seat in your vehicle to be sure it is compatible with the vehicle's seat and seat belt system.
- Make sure the child's head will be properly supported by the booster seat or vehicle seat. The seatback must be at or above the center of the child's ears. For example, if a low back booster seat ① is chosen, the vehicle seatback must be at or above the center of the child's ears. If the seatback is lower than the center of the child's ears, a high back booster seat ② should be used.

- If the booster seat is compatible with your vehicle, place your child in the booster seat and check the various adjustments to be sure the booster seat is compatible with your child. Always follow all recommended procedures.

**All U.S. states and Canadian provinces or territories require that infants and small children be restrained in an approved child restraint at all times while the vehicle is being operated.**



## WARNING

- Improper use of a booster seat can increase the risk or severity of injury for both the child and other occupants of the vehicle.
- Follow all of the booster seat manufacturer's instructions for installation and use. When purchasing a booster seat, be sure to select one which will fit your child and vehicle. It may not be possible to properly install some types of booster seats in your vehicle.

- If the booster seat and seat belt are not used properly, the risk of a child being injured in a collision or a sudden stop greatly increases.
- Adjustable seatbacks should be positioned to fit the booster seat, but as upright as possible.
- After placing the child in the booster seat and fastening the seat belt, make sure the shoulder portion of the belt is away from the child's face and neck and the lap portion of the belt does not cross the abdomen.
- Do not put the shoulder belt behind the child or under the child's arm. If you must install a booster seat in the front seat, see "Booster seat installation on front passenger seat" later in this section.
- When your booster seat is not in use, keep it secured with a seat belt to prevent it from being thrown around in case of a sudden stop or accident.



## CAUTION

Remember that a booster seat left in a closed vehicle can become very hot. Check the seating surface and buckles before placing your child in the booster seat.



**Outboard position**

## BOOSTER SEAT INSTALLATION ON REAR SEAT OUTBOARD OR CENTER POSITIONS



### CAUTION

Do not use the lap/shoulder belt automatic locking mode when using a booster seat with the seat belts. When you install a booster seat in the rear seat, follow these steps:

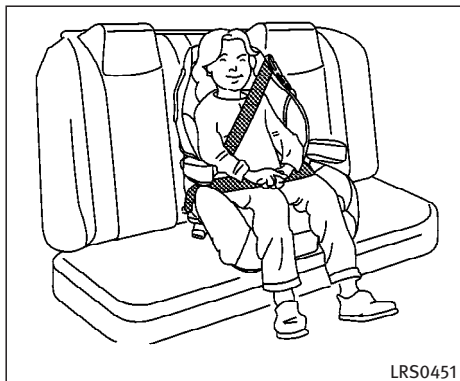

**Center position**

1. Position the booster seat on the seat. Only place it in a front facing direction. Always follow the booster seat manufacturer's instructions.
2. The booster seat should be positioned on the vehicle seat so that it is stable. If necessary, adjust or remove the head restraint to obtain the correct booster seat fit. See "Head restraint adjustment" earlier in this section. If the head restraint is removed, store it in a secure place. Be sure to install the head restraint when the booster seat is removed. If the seating position does not have an adjustable head restraint and it

is interfering with the proper booster seat fit, try another seating position or a different booster seat.

3. Position the lap portion of the seat belt low and snug on the child's hips. Be sure to follow the booster seat manufacturer's instructions for adjusting the belt routing.
4. Pull the shoulder belt portion of the seat belt toward the retractor to take up extra slack. Be sure the shoulder belt is positioned across the top, middle portion of the child's shoulder. Be sure to follow the booster seat manufacturer's instructions for adjusting the belt routing.
5. Follow the warnings, cautions and instructions for properly fastening a seat belt shown in the "Three-point seat belt with retractor" earlier in this section.

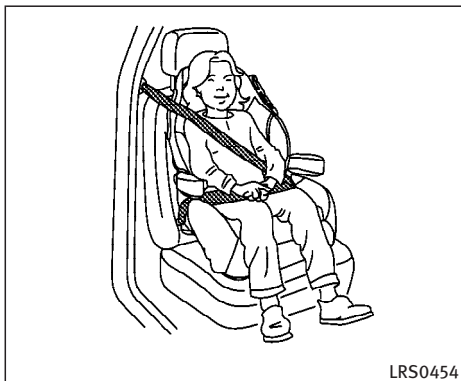

## BOOSTER SEAT INSTALLATION ON FRONT PASSENGER SEAT



### WARNING

INFINITI recommends that child restraints be installed in the rear seat. However, if you must install a booster seat in the front passenger seat, move the passenger seat to the rearmost position. Also, be sure the front passenger air bag status light is illuminated to indicate the passenger air bag is OFF. See

### “Front passenger air bag and status light” later in this section for details.

If you must install a booster seat in the front seat, follow these steps:

1. Move the seat to the rearmost position.
2. Position the booster seat on the seat. Only place it in a front facing direction. Always follow the booster seat manufacturer’s instructions.
3. The booster seat should be positioned on the vehicle seat so that it is stable. If necessary, adjust or remove the head restraint to obtain the correct booster seat fit. See “Head restraint adjustment” earlier in this section. If the head restraint is removed, store it in a secure place. Be sure to install the head restraint when the booster seat is removed. If the seating position does not have an adjustable head restraint and it is interfering with the proper booster seat fit, try another seating position or a different booster seat.
4. Position the lap portion of the seat belt low and snug on the child’s hips. Be sure to follow the booster seat manufacturer’s instructions for adjusting the belt routing.
5. Pull the shoulder belt portion of the seat belt toward the retractor to take up extra slack. Be sure the shoulder belt is positioned across the top, middle portion of the child’s shoulder. Be sure to follow the booster seat manufacturer’s instructions for adjusting the belt routing.
6. Follow the warnings, cautions and instructions for properly fastening a seat belt shown in the “Three-point seat belt with retractor” earlier in this section.
7. When the ignition switch is turned to the ON position, the passenger air bag status light  may or may not be illuminated, depending on the size of the child and the type of booster seat being used. See “Front passenger air bag and status light” later in this section.

## SUPPLEMENTAL RESTRAINT SYSTEM

### PRECAUTIONS ON SUPPLEMENTAL RESTRAINT SYSTEM

This Supplemental Restraint System (SRS) section contains important information concerning the driver and passenger front impact supplemental air bags (INFINITI advanced air bag system), front seat side-impact supplemental air bags, curtain side-impact and rollover air bags and front seat pre-tensioner seat belts.

**Supplemental front impact air bag system:**

The INFINITI advanced air bag system can help cushion the impact force to the head and chest of the driver and front passenger in certain frontal collisions.

**Supplemental side-impact air bag system:**

This system can help cushion the impact force to the chest area of the driver and front passenger in certain side impact collisions. The front seat side-impact supplemental air bags are designed to inflate on the side where the vehicle is impacted.

**Supplemental curtain side-impact and rollover air bag system:**

This system can help cushion the impact force to the head of occupants in front and rear outboard seating positions in certain side impact or rollover collisions. In a side impact, the curtain air bags are designed to inflate on the side where the vehicle is impacted. In a rollover both cur-

tain air bags are designed to inflate and remain inflated for a short period of time.

These supplemental restraint systems are designed to **supplement** the crash protection provided by the driver and passenger seat belts and are **not a substitute** for them. Seat belts should always be correctly worn and the occupant seated a suitable distance away from the steering wheel, instrument panel and door finishers. (See “Seat belts” earlier in this section for instructions and precautions on seat belt usage.)

**After turning the ignition switch to the ON position, the supplemental air bag warning light illuminates. The supplemental air bag warning light will turn off after about 7 seconds if the systems are operational.**

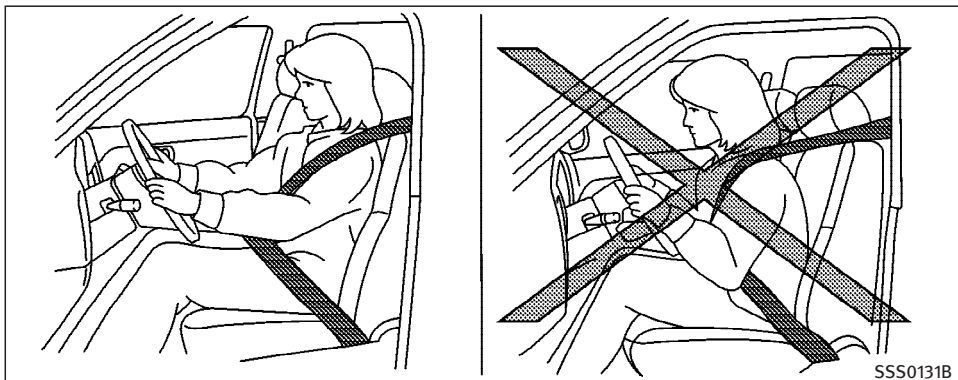

## WARNING

- The supplemental front air bags ordinarily will not inflate in the event of a side impact, rear impact, rollover, or lower severity frontal collision. Always wear your seat belts to help reduce the risk or severity of injury in various kinds of accidents.
- The front passenger air bag will not inflate if the passenger air bag status light

is lit or if the front passenger seat is unoccupied. See “Front passenger air bag and status light” later in this section.

- The seat belts and the supplemental front air bags are most effective when you are sitting well back and upright in the seat. The front air bags inflate with great force. Even with the INFINITI Advanced Air Bag System, if you are unrestrained, leaning forward, sitting sideways or out of position in any way, you

are at greater risk of injury or death in a crash. You may also receive serious or fatal injuries from the supplemental front air bag if you are up against it when it inflates. Always sit back against the seat-back and as far away as practical from the steering wheel or instrument panel. Always use the seat belts.

- The driver and front passenger seat belt buckles are equipped with sensors that detect if the seat belts are fastened. The advanced air bag system monitors the severity of a collision and seat belt usage then inflates the air bags. Failure to properly wear seat belts can increase the risk or severity of injury in an accident.
- The front passenger seat is equipped with an occupant classification sensor (pressure sensor) that turns the front passenger air bag OFF under some conditions. This sensor is only used in this seat. Failure to be properly seated and wearing the seat belt can increase the risk or severity of injury in an accident. See “Front Passenger air bag and status light” later in this section.



- Keep hands on the outside of the steering wheel. Placing them inside the steering wheel rim could increase the risk that they are injured when the supplemental front air bag inflates.

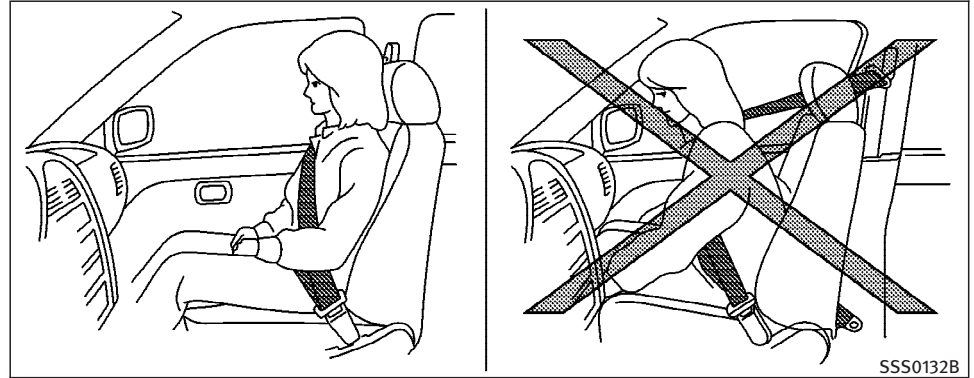

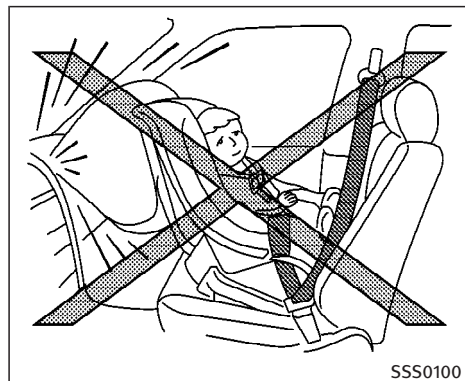
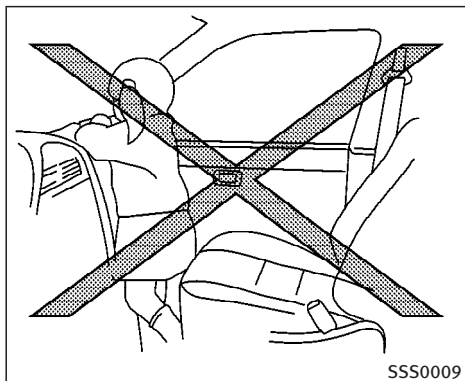
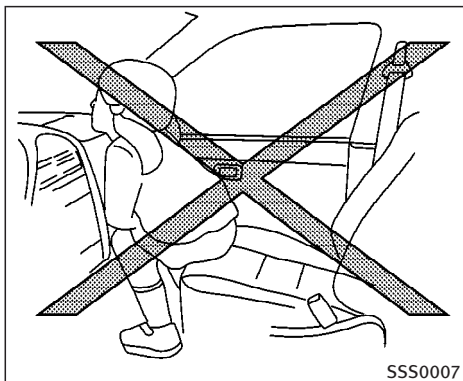
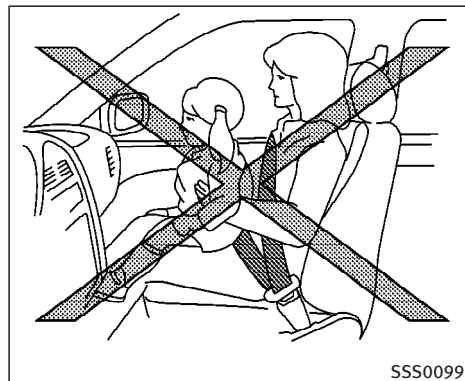
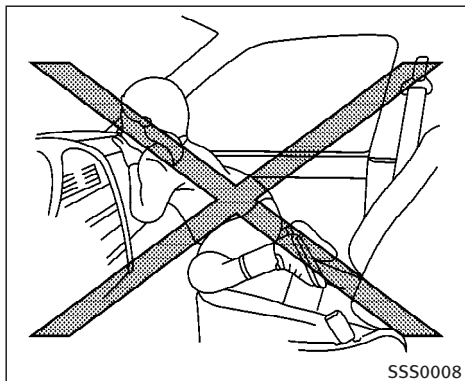
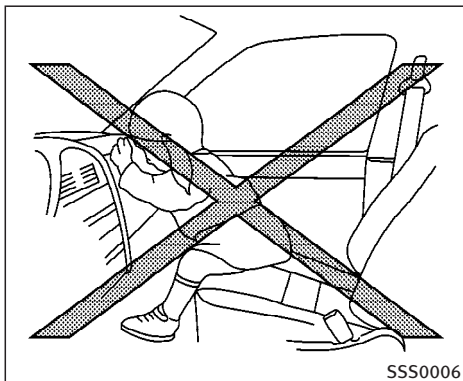



## WARNING

- Never let children ride unrestrained or extend their hands or face out of the window. Do not attempt to hold them in your lap or arms. Some examples of dangerous riding positions are shown in the previous illustrations.
- Children may be severely injured or killed when the supplemental front air bags, side air bags or curtain side-impact and rollover air bags inflate if they are not properly restrained. Pre-teens and children should be properly restrained in the rear seat, if possible.
- Even with the INFINITI Advanced Air Bag System, never install a rear-facing child restraint in the front seat. An inflating supplemental front air bag could seriously injure or kill your child. See “Child restraints” earlier in this section for details.

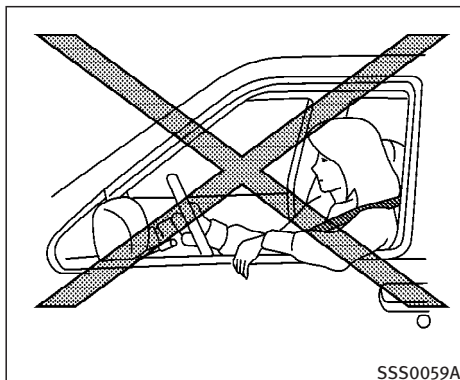

## WARNING

Supplemental side air bag and curtain side-impact and rollover air bag:

- The supplemental side air bag and curtain side-impact and rollover air bag ordinarily will not inflate in the event of a frontal impact, rear impact or lower severity side collision. Always wear your seat belts to help reduce the risk or severity of injury in various kinds of accidents.

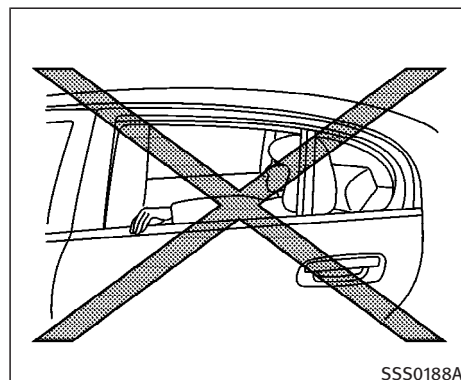

- The seat belts, the supplemental side air bags and curtain side-impact and rollover air bags are most effective when you are sitting well back and upright in the seat. The side air bag and curtain side-impact air bag inflate with great force. Do not allow anyone to place their hand, leg or face near the side air bag on the side of the seatback of the front seat or near the side roof rails. Do not allow anyone sitting in the front seats or rear outboard seats to extend their hand out of the

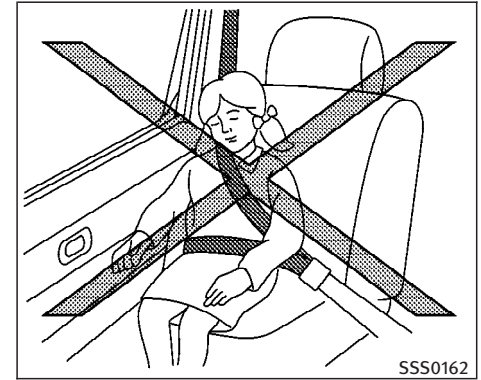
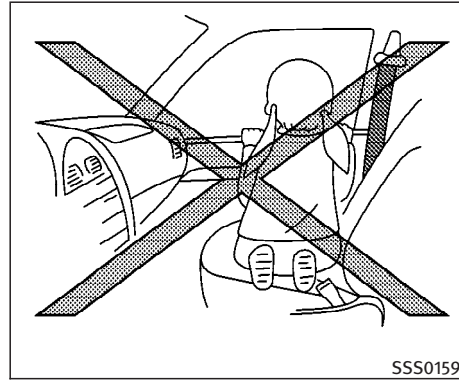
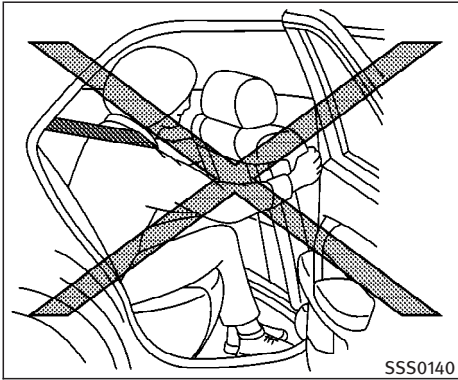

window or lean against the door. Some examples of dangerous riding positions are shown in the illustrations.

- When sitting in the rear seat, do not hold onto the seatback of the front seat. If the side air bag inflates, you may be seriously injured. Be especially careful with children, who should always be properly restrained.

- Do not use seat covers on the front seatbacks. They may interfere with supplemental side air bag inflation.

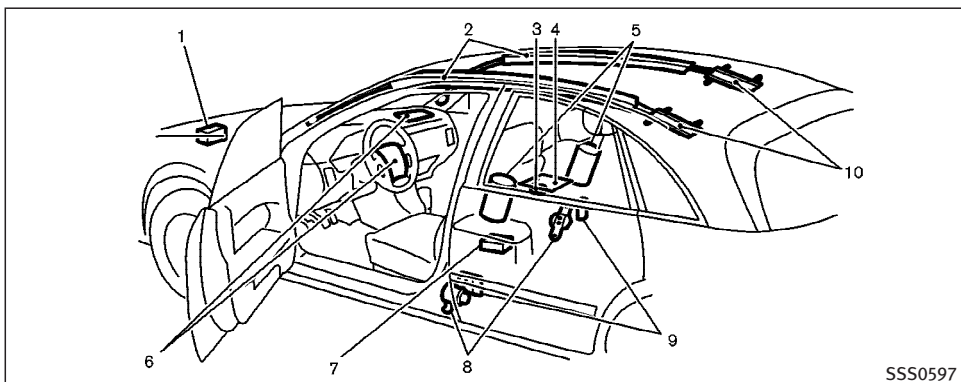

SSS0597

1. Crash zone sensor
2. Supplemental curtain side-impact and rollover air bags
3. Occupant classification system control unit
4. Occupant classification sensor (pressure sensor)
5. Supplemental side air bag modules
6. Supplemental front air bag modules
7. Diagnosis sensor unit
8. Seat belt pre-tensioner retractor

9. Satellite sensors
10. Supplemental curtain side-impact and rollover air bag modules

### INFINITI ADVANCED AIR BAG SYSTEM (front seats)

This vehicle is equipped with the INFINITI advanced air bag system for the driver and front passenger seats. This system is designed to meet certification requirements under U.S. regulations. It is also permitted in Canada. **However, all of the information, cautions and warnings in this manual still apply and must be followed.**

The driver supplemental front air bag is located in the center of the steering wheel. The front passenger supplemental front air bag is mounted in the instrument panel above the glove box. The supplemental front air bags are designed to inflate in higher severity frontal collisions, although they may inflate if the forces in another type of collision are similar to those of a higher severity frontal impact. They may not inflate in certain frontal collisions. Vehicle damage (or lack of it) is not always an indication of proper supplemental air bag system operation.

The INFINITI advanced air bag system has dual stage inflators. It also monitors information from the crash zone sensor, the diagnosis sensor unit, seat belt buckle switches, occupant classification sensor (pressure sensor) and passenger seat belt tension sensor. Inflator operation is based on the severity of a collision and seat belt usage of the driver. For the front passenger, it additionally monitors the weight of an occupant or object on the seat and seat belt tension. Based on information from the sensors, only one front air bag may inflate in a crash, depending on the crash severity and whether the front occupants are belted or unbelted. Additionally,

the front passenger air bag may be automatically turned OFF under some conditions, depending on the weight detected on the passenger seat and how the seat belt is used. If the front passenger air bag is OFF, the passenger air bag status light will be illuminated (if the seat is unoccupied, the light will not be illuminated, but the air bag will be off.). See “Front passenger air bag and status light” later in this section for further details. One front air bag inflating does not indicate improper performance of the system.

If you have any questions about your air bag system, contact an INFINITI dealer. If you are considering modifications of your vehicle due to a disability, you may also contact an INFINITI dealer. Contact information is contained in the front of this Owner’s Manual.

When a supplemental front air bag inflates, a fairly loud noise may be heard, followed by release of smoke. This smoke is not harmful and does not indicate a fire. Care should be taken to not inhale it, as it may cause irritation and choking. Those with a history of a breathing condition should get fresh air promptly.

Supplemental front air bags, along with the use of seat belts, help to cushion the impact force on the face and chest of the front occupants. They can help save lives and reduce serious injuries. However, an inflating front air bag may cause facial abrasions or other injuries. Front air bags do not provide restraint to the lower body.

Even with INFINITI advanced air bags, seat belts should be correctly worn and the driver and passenger seated upright as far as practical away from the steering wheel or instrument panel. The supplemental front air bags inflate quickly in order to help protect the front occupants. Because of this, the force of the front air bag inflating can increase the risk of injury if the occupant is too close to, or is against the front air bag module during inflation.

The front air bags deflate quickly after a collision.

**The supplemental front air bags operate only when the ignition switch is in the ON or START position.**

**After turning the ignition switch to the ON position, the supplemental air bag warning light illuminates. The supplemental air bag warning light will turn off after about 7 seconds if the system is operational.**



## Front passenger air bag and status light



### WARNING

The front passenger air bag is designed to automatically turn OFF under some conditions. Read this section carefully to learn how it operates. Proper use of the seat, seat belt and child restraints is necessary for most effective protection. Failure to follow

all instructions in this manual concerning the use of seats, seat belts and child restraints can increase the risk or severity of injury in an accident.

### Status light:

The front passenger air bag status light  is located on the map light cover. The light operates as follows:

- Unoccupied passenger seat: The  is OFF and the front passenger air bag is OFF and will not inflate in a crash.
- Passenger seat occupied by a small adult, child or child restraint as outlined in this section: The  illuminates to indicate that the front passenger air bag is OFF and will not inflate in a crash.
- Occupied passenger seat and the passenger meets the conditions outlined in this section: The light  is OFF to indicate that the front passenger air bag is operational.

### Front passenger air bag:

The front passenger air bag is designed to automatically turn OFF when the vehicle is operated under some conditions as described below in accordance with U.S. regulations. If the front passenger air bag is OFF, it will not inflate in a crash. The driver air bag and other air bags in your vehicle are not part of this system.

The purpose of the regulation is to help reduce the risk of injury or death from an inflating air bag to certain front passenger seat occupants, such as children, by requiring the air bag to be automatically turned OFF. Certain sensors are used to meet the requirements.

One sensor used is the occupant classification sensor (pressure sensor). It is in the bottom of the front passenger seat cushion and is designed to detect an occupant and objects on the seat by weight. It works together with seat belt sensors described later. For example, if a child is in the front passenger seat, the advanced air bag system is designed to turn the passenger air bag OFF in accordance with the regulations. Also, if a child restraint of the type specified in the regulations is on the seat, its weight and the child's weight can be de-

tected and cause the air bag to turn OFF. The occupant classification sensor operation can vary depending on the front passenger seat belt sensors.

The front passenger seat belt sensors are designed to detect if the seat belt is buckled and the amount of tension on the seat belt, such as when it is in the automatic locking mode (child restraint mode). Based on the weight on the seat detected by the occupant classification sensor and the belt tension detected on the seat belt, the advanced air bag system determines whether the front passenger air bag should be automatically turned OFF as required by the regulations.

Front passenger seat adult occupants who are properly seated and using the seat belt as outlined in this manual should not cause the passenger air bag to be automatically turned OFF. For small adults it may be turned OFF. However, if the occupant takes his/her weight off the seat cushion (for example, by not sitting upright, by sitting on an edge of the seat, or by otherwise being out of position), this could cause the sensor to turn the air bag OFF. In addition, if the occupant improperly uses the seat belt in the automatic locking mode (child restraint mode), this could

cause the air bag to be turned OFF. Always be sure to be seated and wearing the seat belt properly for the most effective protection by the seat belt and supplemental air bag.

INFINITI recommends that pre-teens and children be properly restrained in a rear seat. INFINITI also recommends that appropriate child restraints and booster seats be properly installed in a rear seat. If this is not possible, the occupant classification sensor and seat belt sensors are designed to operate as described above to turn the front passenger air bag OFF for specified child restraints as required by the regulations. Failing to properly secure child restraints and to use the automatic locking mode (child restraint mode) may allow the restraint to tip or move in an accident or sudden stop. This can also result in the passenger air bag inflating in a crash instead of being OFF. See “Child restraints” earlier in this section for proper use and installation.

If the front passenger seat is not occupied, the passenger air bag is designed not to inflate in a crash. However, heavy objects placed on the seat could result in air bag inflation, because of the object’s weight detected by the occupant classification

sensor. Other conditions could also result in air bag inflation, such as if a child is standing on the seat, or if two children are on the seat, contrary to the instructions in this manual. Always be sure that you and all vehicle occupants are seated and restrained properly.

Using the passenger air bag status light, you can monitor when the front passenger air bag is automatically turned OFF with the seat occupied. The light will not illuminate when the front passenger seat is unoccupied.

If an adult occupant is in the seat but the passenger air bag status light is illuminated (indicating that the air bag is OFF), it could be that the person is a small adult, or is not sitting on the seat properly or is not using the seat belt properly.

If a child restraint must be used in the front seat, the passenger air bag status light may or may not be illuminated, depending on the size of the child and the type of child restraint being used. If the passenger air bag status light is not illuminated (indicating that the air bag might inflate in a crash), it could be that the child restraint or seat belt is not being used properly. In rare cases, the passenger air bag status light



will not illuminate even though the air bag is OFF.

If such situations happen, properly position and restrain the occupant or child restraint. Otherwise reposition the occupant or child restraint in a rear seat. If you have any questions about whether your passenger air bag is working as designed, your INFINITI dealer can confirm that it is working properly by using a special tool.

The air bag system and passenger air bag status light will take a few seconds to register a change in the passenger seat status. For example, if a large adult who is sitting in the front passenger seat exits the vehicle, the passenger air bag status light will change from OFF to ON for a few seconds and then to OFF. This is normal system operation and does not indicate a malfunction.

If a malfunction occurs in the front passenger air bag system, the supplemental air bag warning light  , located in the meter and gauges area, will blink. Have the system checked by an INFINITI dealer.

## Other supplemental front air bag precautions



### WARNING

- Do not place any objects on the steering wheel pad or on the instrument panel. Also, do not place any objects between any occupant and the steering wheel or instrument panel. Such objects may become dangerous projectiles and cause injury if the supplemental front air bag inflates.
- Immediately after inflation, several front air bag system components will be hot. Do not touch them; you may severely burn yourself.
- No unauthorized changes should be made to any components or wiring of the supplemental air bag system. This is to prevent accidental inflation of the supplemental air bag or damage to the supplemental air bag system.
- Do not make unauthorized changes to your vehicle's electrical system, suspen-

sion system or front end structure. This could affect proper operation of the supplemental air bag system.

- Tampering with the supplemental front air bag system may result in serious personal injury. Tampering includes changes to the steering wheel and the instrument panel assembly by placing material over the steering wheel pad and above the instrument panel or by installing additional trim material around the air bag system.
- Modifying or tampering with the front passenger seat may result in serious personal injury. For example, do not change the front seats by placing material on the seat cushion or by installing additional trim material, such as seat covers, on the seat. Additionally, do not stow any objects under the front passenger seat or the seat cushion and seatback. Such objects may interfere with the proper operation of the occupant classification sensor (pressure sensor).

- No unauthorized changes should be made to any components or wiring of the seat belt system. This may affect the supplemental front air bag system. Tampering with the seat belt system may result in serious personal injury.
- Work on and around the supplemental front air bag system should be done by an INFINITI dealer. Installation of electrical equipment should also be done by an INFINITI dealer. The Supplemental Restraint System (SRS) wiring should not be modified or disconnected. Unauthorized electrical test equipment and probing devices should not be used on the air bag system.
- A cracked windshield should be replaced immediately by a qualified repair facility. A cracked windshield could affect the function of the supplemental air bag system.
- The SRS wiring harness connectors are yellow and orange for easy identification.

When selling your vehicle, we request that you inform the buyer about the supplemental front air bag system and guide the buyer to the appropriate sections in this Owner's Manual.

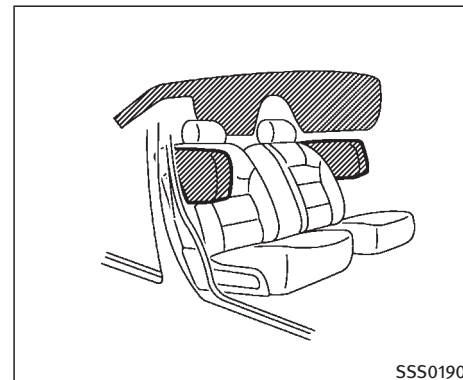

### Supplemental side air bag and curtain side-impact and rollover air bag system

The supplemental side air bags are located in the outside of the seatback of the front seats. The supplemental curtain side-impact and rollover air bags are located in the side roof rails. These systems are designed to meet voluntary guidelines to help reduce the risk of injury to out-of-position occupants. **However, all of the information, cautions and warnings in this manual still apply and must be followed.** The supplemental side air bags and curtain side-

impact and rollover air bags are designed to inflate in higher severity side collisions, although they may inflate if the forces in another type of collision are similar to those of a higher severity side impact. They are designed to inflate on the side where the vehicle is impacted. They may not inflate in certain side collisions.

Curtain side-impact and rollover air bags are also designed to inflate in certain types of rollover collisions or near rollovers. Vehicle damage (or lack of it) is not always an indication of proper supplemental side air bag and curtain side-impact and rollover air bag operation.

When the supplemental side air bag and curtain side-impact air bag inflate, a fairly loud noise may be heard, followed by release of smoke. This smoke is not harmful and does not indicate a fire. Care should be taken not to inhale it, as it may cause irritation and choking. Those with a history of a breathing condition should get fresh air promptly.

Supplemental side air bags, along with the use of seat belts, help to cushion the impact force on the chest of the front occupants. Curtain side-impact and rollover air bags help to cushion the impact force to

the head of occupants in the front and rear outboard seating positions. They can help save lives and reduce serious injuries. However, an inflating side air bag and curtain side-impact air bag may cause abrasions or other injuries. Supplemental side air bags and curtain side-impact and rollover air bags do not provide restraint to the lower body.

The seat belts should be correctly worn and the driver and passenger seated upright as far as practical away from the side air bag. Rear seat passengers should be seated as far away as practical from the door finishers and side roof rails. The side air bags and curtain side-impact air bag inflate quickly in order to help protect the front occupants and rear-outboard occupants. Because of this, the force of the side air bag and curtain air bag inflating can increase the risk of injury if the occupant is too close to, or is against, these air bag modules during inflation. The side air bag will deflate quickly after the collision is over.

The curtain side-impact and rollover air bag will remain inflated for a short time.

**The supplemental side air bags and curtain side-impact and rollover air bags operate only when the ignition switch is in the ON or START position.**

**After turning the ignition switch to the ON position, the supplemental air bag warning light illuminates. The supplemental air bag warning light will turn off after about 7 seconds if the systems are operational.**



## **WARNING**

- **Do not place any objects near the seat-back of the front seats. Also, do not place any objects (an umbrella, bag, etc.) between the front door finisher and the front seat. Such objects may become dangerous projectiles and cause injury if the side air bag or curtain side-impact air bag inflates.**
- **Immediately after inflation, several side air bag and curtain side-impact and rollover air bag system components will be hot. Do not touch them; you may severely burn yourself.**

- No unauthorized changes should be made to any components or wiring of this side air bag and curtain side-impact air bag system. This is to prevent accidental inflation of the side air bag and curtain side-impact air bag or damage to the side air bag and curtain side-impact air bag system.
- Do not make unauthorized changes to your vehicle's electrical system, suspension system or side panel. This could affect proper operation of the supplemental side air bag and curtain side-impact air bag system.
- Tampering with the supplemental system may result in serious personal injury. For example, do not change the front seat by placing material near the seatback or by installing additional trim material, such as seat covers, around the side air bag.
- Work around and on the side air bag and curtain side-impact air bag system should be done by an INFINITI dealer. Installation of electrical equipment

should also be done by an INFINITI dealer. The SRS wiring harnesses\* should not be modified or disconnected. Unauthorized electrical test equipment and probing devices should not be used on the side air bag system.

- \* The SRS wiring harnesses connectors are yellow for easy identification.

When selling your vehicle, we request that you inform the buyer about the side air bag and curtain side-impact air bag system and guide the buyer to the appropriate sections in this Owner's Manual.

Pre-tensioner seat belt system (For front seats)



## WARNING

- The pre-tensioner seat belt cannot be re-used after activation. It must be replaced together with the retractor and buckle as a unit.
- If the vehicle becomes involved in a frontal collision but the pre-tensioner is not

activated, be sure to have the pretensioner system checked and, if necessary, replaced by an INFINITI dealer.

- No unauthorized changes should be made to any components or wiring of the pre-tensioner seat belt system. This is to prevent accidental activation of the pre-tensioner seat belt or damage to the pre-tensioner seat belt operation. Tampering with the pre-tensioner seat belt system may result in serious personal injury.
- Work around and on the pre-tensioner system should be done by an INFINITI dealer. Installation of electrical equipment should also be done by an INFINITI dealer. Unauthorized electrical test equipment and probing devices should not be used on the pre-tensioner seat belt system.
- If you need to dispose of the pre-tensioner or scrap the vehicle, contact an INFINITI dealer. Correct pre-tensioner disposal procedures are set forth in the appropriate INFINITI Service Manual. Incorrect disposal procedures could cause personal injury.

The front seat pre-tensioner seat belt system activates in conjunction with the front supplemental air bag systems. Working with the seat belt retractor, it helps tighten the seat belt when the vehicle becomes involved in certain types of collisions, helping to restrain front seat occupants.

The pre-tensioner is encased with the seat belt's retractor. These seat belts are used in the same way as conventional seat belts.

When the pre-tensioner seat belt activates, smoke is released and a loud noise may be heard. The smoke is not harmful and does not indicate a fire. Care should be taken not to inhale it as it may cause irritation and choking. Those with a history of a breathing condition should get fresh air promptly.

If any abnormality occurs in the pre-tensioner system, the supplemental air bag warning light  will not come on, will flash intermittently or will turn on for 7 seconds and remain on after the ignition switch has been turned to the ON or START position. In this case, the pre-tensioner seat belt may not function properly. They must be checked and repaired. Take your vehicle to an INFINITI dealer.

When selling your vehicle, we request that you inform the buyer about the pre-tensioner seat belt system and guide the buyer to the appropriate sections in this Owner's Manual.

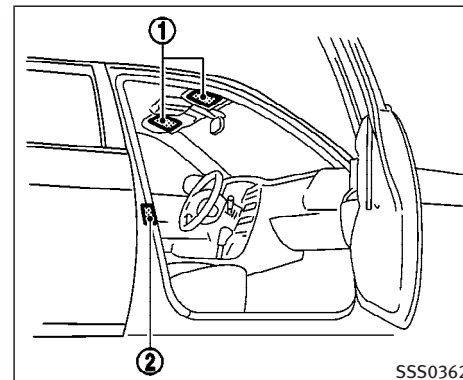

### ① SRS air bag

The warning labels are located on the surface of the sun visor.

### ② SRS side-impact air bag

The warning label is located on the side of the passenger's side center pillar.

## SUPPLEMENTAL AIR BAG WARNING LABELS

Warning labels about the supplemental front air bag and supplemental side-impact air bag systems are placed in the vehicle as shown in the illustration.



## SUPPLEMENTAL AIR BAG WARNING LIGHT

The supplemental air bag warning light, displaying  in the instrument panel, monitors the circuits of the supplemental front air bag, supplemental side air bag and curtain side-impact and rollover air bag systems, and pre-tensioner seat belt systems. The circuits monitored by the air bag warning light are the diagnosis sensor unit, crash zone sensor, rollover sensors, satellite sensors, front air bag modules, side air bag modules, curtain side-impact

air bag modules, pre-tensioner seat belts and all related wiring.

After turning the ignition switch to the ON or START position, the supplemental air bag warning light illuminates. The supplemental air bag warning light will turn off after about 7 seconds if the system is operational.

If any of the following conditions occur, the supplemental front air bag, supplemental side air bag and curtain side-impact air bag systems, and pre-tensioner seat belt systems need servicing:

- The supplemental air bag warning light remains on after approximately 7 seconds.
- The supplemental air bag warning light flashes intermittently.
- The supplemental air bag warning light does not come on at all.

Under these conditions, the supplemental front air bags, supplemental side air bags, curtain side-impact air bags and/or pre-tensioner seat belt may not operate properly. It must be checked and repaired. Take your vehicle to an INFINITI dealer.



## WARNING

**If the supplemental air bag warning light is on, it could mean that the supplemental front air bag, supplemental side air bag, curtain air bag systems and/or pre-tensioner seat belt system will not operate in an accident. To help avoid injury to yourself or others, have your vehicle checked by an INFINITI dealer as soon as possible.**

## Repair and replacement procedure

The supplemental front air bags, supplemental side air bags, curtain side-impact air bags and pre-tensioner seat belt are designed to inflate on a one-time-only basis. As a reminder, unless it is damaged, the supplemental air bag warning light will remain illuminated after inflation has occurred. Repair and replacement of these systems should be done only by an INFINITI dealer.

When maintenance work is required on the vehicle, the supplemental front air bags, side air bags, curtain air bags, related parts and pre-tensioner seat belt should be

pointed out to the person conducting the maintenance. The ignition switch should always be in the LOCK position when working under the hood or inside the vehicle.



## **WARNING**

- Once a supplemental front air bag, supplemental side air bag or curtain air bag has inflated, the air bag module will not function again and must be replaced. Additionally, if any of the supplemental front air bags inflate, the activated pretensioner seat belts must also be replaced. The air bag module and pretensioner seat belt system should be replaced by an INFINITI dealer. The air bag modules and pretensioner seat belt system cannot be repaired.
- The supplemental front air bag, side air bag and curtain side-impact/rollover air bag systems, and pretensioner seat belt system should be inspected by an INFINITI dealer if there is any damage to the front end or side portion of the vehicle.

- If you need to dispose of these supplemental systems or scrap the vehicle, contact an INFINITI dealer. Correct disposal procedures are set forth in the appropriate INFINITI Service Manual. Incorrect disposal procedures could cause personal injury.

## 2 Instruments and controls

Instrument panel.....	2-2	Daytime running light system (Canada only) .....	2-27
Meters and gauges .....	2-3	Instrument brightness control .....	2-27
Speedometer and odometer.....	2-4	Turn signal switch .....	2-28
Tachometer .....	2-4	Fog light switch .....	2-28
Engine coolant temperature gauge .....	2-5	Hazard warning flasher switch.....	2-28
Fuel gauge .....	2-5	Horn.....	2-29
Compass display .....	2-6	Heated seats (if so equipped) .....	2-29
Warning/indicator lights and audible reminders.....	2-9	Lane departure warning (LDW) switch (if so equipped) .....	2-30
Checking bulbs.....	2-9	SNOW mode switch.....	2-31
Warning lights .....	2-10	Vehicle dynamic control (VDC) off switch .....	2-31
Indicator lights .....	2-15	Clock.....	2-32
Audible reminders .....	2-17	Adjusting the time .....	2-32
Security systems .....	2-18	Power outlet .....	2-32
Vehicle security system .....	2-18	Storage .....	2-34
INFINITI Vehicle Immobilizer System .....	2-20	Sunglasses holder .....	2-34
Windshield wiper and washer switch .....	2-21	Storage box.....	2-35
Rear window wiper and washer switch .....	2-22	Cup holders.....	2-35
Rear window and outside mirror defroster switch .....	2-23	Glove box.....	2-36
Headlight and turn signal switch .....	2-23	Console box .....	2-38
Xenon headlights .....	2-23	Luggage floor boxes (if so equipped) .....	2-39
Headlight switch .....	2-24	Card holder (for driver's side).....	2-39
		Cargo net (if so equipped).....	2-39



Tonneau cover (if so equipped) .....	2-40
Windows .....	2-41
Power windows .....	2-41
Sunroof (if so equipped).....	2-43
Automatic sunroof .....	2-43
Interior light.....	2-45
Room light.....	2-45
Map light .....	2-45
Ceiling light (if so equipped) .....	2-46
Rear personal light .....	2-46
Luggage room light.....	2-47
Vanity mirror light.....	2-47

HomeLink <sup>®</sup> Universal Transceiver (if so equipped).....	2-47
Programming HomeLink <sup>®</sup> .....	2-48
Programming HomeLink <sup>®</sup> for Canadian customers .....	2-49
Operating the HomeLink <sup>®</sup> Universal Transceiver.....	2-50
Programming trouble-diagnosis .....	2-50
Clearing the programmed information .....	2-50
Reprogramming a single HomeLink <sup>®</sup> button .....	2-50
If your vehicle is stolen.....	2-51

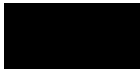

## INSTRUMENT PANEL

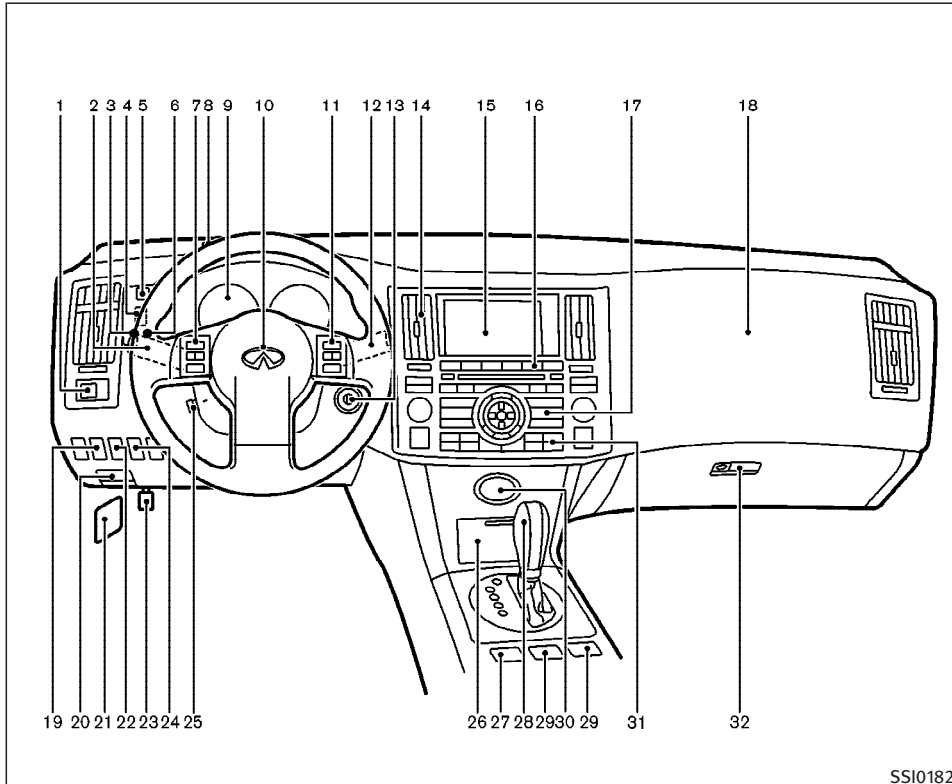

1. Outside mirror remote control
2. Headlight, fog light and turn signal switch
3. Trip odometer reset knob
4. Instrument brightness control switch
5. Headlight aiming control switch
6. Trip odometer select knob
7. Steering switch for Audio/Bluetooth® Hands-Free Phone System (if so equipped)
8. Security indicator light
9. Meters and gauges
10. Driver supplemental air bag
11. Cruise control main/set switch or Intelligent cruise control switch (if so equipped)
12. Windshield wiper/washer switch
13. Ignition switch
14. Center ventilator
15. Display/Navigation system (if so equipped)\*
16. Audio system
17. Center multi-function control panel
18. Front passenger supplemental air bag
19. Lane departure warning (LDW) switch (if so equipped)
20. Hood release handle
21. Fuse box
22. SNOW mode switch
23. Parking brake

SSI0182

## METERS AND GAUGES

- 24. Vehicle dynamic control (VDC) OFF switch
- 25. Tilting/telescopic steering wheel switch
- 26. Storage box and power outlet
- 27. Hazard warning flasher switch
- 28. Automatic transmission selector lever
- 29. Heated seat switch
- 30. Clock
- 31. Automatic climate control system
- 32. Glove box

\*: Refer to the separate Navigation System Owner's Manual. (if so equipped)

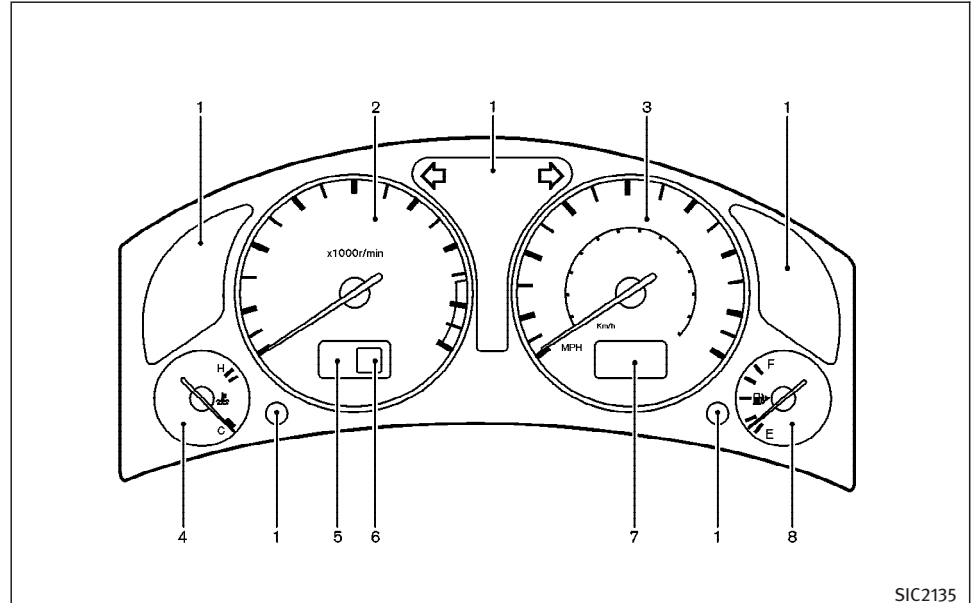

SIC2135

- 1. Warning/Indicator lights
- 2. Tachometer
- 3. Speedometer
- 4. Engine coolant temperature gauge
- 5. Intelligent cruise control system display (if so equipped)
- 6. Automatic transmission position indicator
- 7. Odometer (Total/Twin trip)
- 8. Fuel gauge

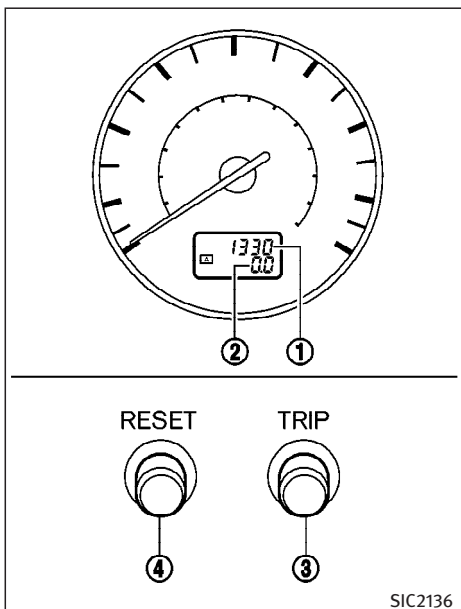

## SPEEDOMETER AND ODOMETER

### Speedometer

The speedometer indicates vehicle speed (MPH and km/h).

### 2-4 Instruments and controls

## Odometer/Twin trip odometer

The odometer/twin trip odometer are displayed when the ignition switch is in the ON position.

The odometer ① records the total distance the vehicle has been driven.

The twin trip odometer ② records the distance of individual trips.

### Changing the display:

Pushing the trip knob ③ changes the display as follows:

TRIP A → TRIP B → TRIP A

### Resetting the trip odometer:

Push and hold the reset knob ④ to reset the trip odometer to zero.

Elapsed time, driving distance and average speed information are also available. Refer to “How to use “TRIP” button” in the “4. Display screen, heater, air conditioner and audio systems” section.

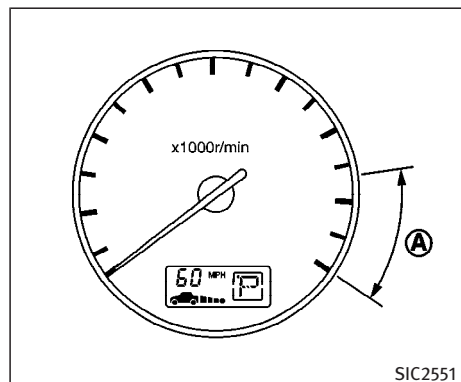

## TACHOMETER

The tachometer indicates engine speed in revolutions per minute (rpm).

Do not rev the engine into the red zone ①.



## CAUTION

When engine speed approaches the red zone, shift to a higher gear. Operating the engine in the red zone may cause serious engine damage.

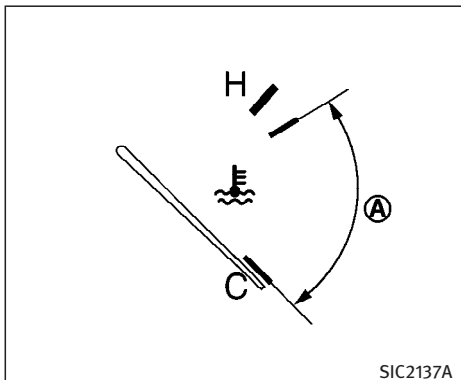

SIC2137A

## ENGINE COOLANT TEMPERATURE GAUGE

The gauge indicates the engine coolant temperature.

The engine coolant temperature is normal when the gauge indicates within the range **A**.

The engine coolant temperature will vary with the outside air temperature and driving conditions.



## CAUTION

If the gauge indicates engine coolant temperature near the hot (H) end of the normal range, reduce vehicle speed to decrease temperature. If the gauge is over the normal range **A**, stop the vehicle as soon as safely possible. If the engine is overheated, continued operation of the vehicle may seriously damage the engine. See “If your vehicle overheats” in the “6. In case of emergency” section for immediate action required.

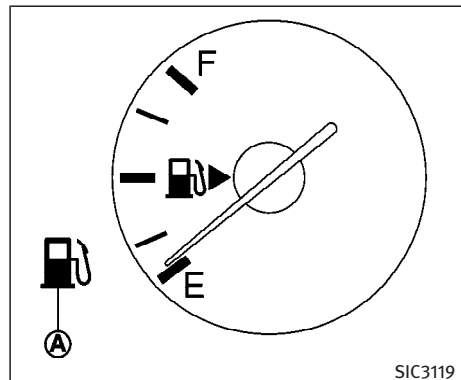

SIC3119

## FUEL GAUGE

The gauge indicates the approximate fuel level in the tank.

The gauge may move slightly during braking, turning, acceleration, or going up or down hill.

The gauge needle is designed to move to the E (Empty) position when the ignition switch is turned to the OFF position.

**Refill the fuel tank before the gauge registers Empty.**

## COMPASS DISPLAY

The low fuel warning light **(A)** comes on when the fuel tank is getting low. Refuel as soon as it is convenient, preferably before the gauge reaches E. There will be a small reserve of fuel in the tank when the fuel gauge needle reaches E.

The  indicates that the fuel-filler door is located on the passenger's side of the vehicle.



### CAUTION

- If the vehicle runs out of fuel, the **SERVICE ENGINE SOON** malfunction indicator lamp (MIL) may come on. Refuel as soon as possible. After a few driving trips, the **SERVICE ENGINE SOON** lamp should turn off. If the lamp remains on after a few driving trips, have the vehicle inspected by an INFINITI dealer.
- For additional information, see “Malfunction indicator lamp (MIL)” later in this section.

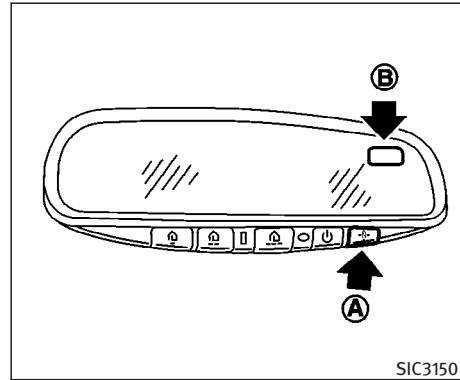

Type A

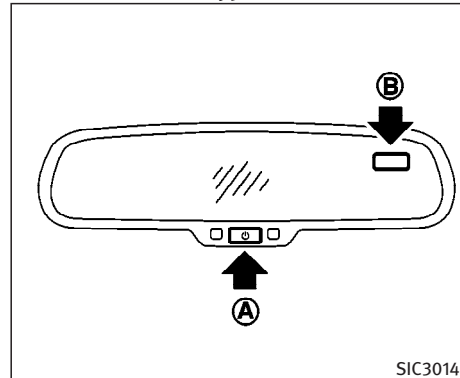

Type B

When the compass switch **(A)** is pushed, the compass display **(B)** will indicate the direction the vehicle is heading.

N: north

E: east

S: south

W: west

If the display reads “C” or compass switch **(A)** is pushed for 9 seconds (Type B), calibrate the compass by driving the vehicle in 3 complete circles at less than 5 MPH (8 km/h).

You can also calibrate the compass by driving your vehicle on your everyday route. The compass will be calibrated once it has tracked 3 complete circles.

To turn off the compass, push **(A)** again.

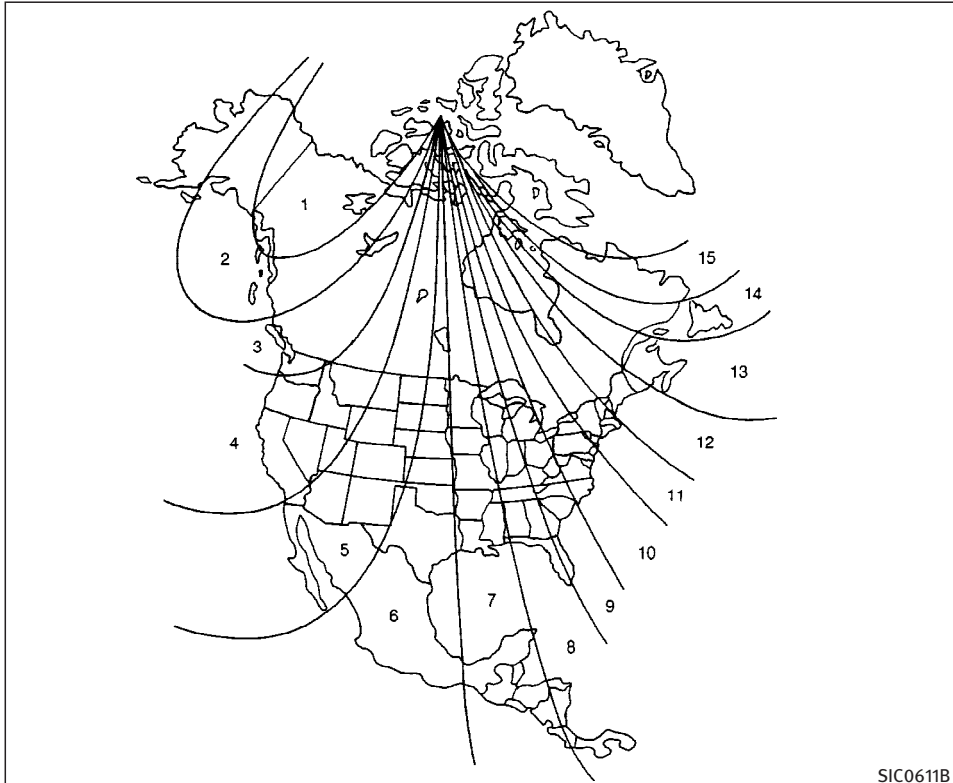

SIC0611B

## Zone variation change procedure

The difference between magnetic north and geographical north is known as variance. In some areas, this difference can sometimes be great enough to cause false compass readings. Follow these instructions to set the variance for your particular location if this happens:

1. Push the compass switch for more than 3 seconds. The current zone number will appear in the display.
2. Find your current location and variance number on the zone map.
3. Push and hold the compass switch until the new zone number appears in the display, then release the switch. After you release the switch, the display will show a compass direction within a few seconds.

### Inaccurate compass direction:

1. With the display turned on, push the compass switch for 3 seconds, until a zone selection number is displayed in the mirror compass window.
2. Push the compass switch repeatedly (toggle) until the correct zone is displayed, then release the switch.

3. The display returns to the normal compass mode within 10 seconds after the switch is released.
4. If the vehicle changes zone, repeat steps 1 thru 3. See map.
  - If the compass deviates from the correct direction after repeated adjustment, have the compass checked at an INFINITI dealer.
  - The compass may not indicate the correct compass point in tunnels or while driving up or down a steep hill. (The compass returns to the correct compass point when the vehicle moves to an area where the geomagnetism is stabilized.)

**cleaner directly on the mirror as it may cause the liquid cleaner to enter the mirror housing.**

































## **CAUTION**

- **Do not install a ski rack, antenna, etc. which are attached to the vehicle by means of a magnet. They affect the operation of the compass.**
- **When cleaning the mirror, use a paper towel or similar material dampened with glass cleaner. Do not spray glass**







## WARNING/INDICATOR LIGHTS AND AUDIBLE REMINDERS

	All-Wheel Drive (AWD) warning light (AWD models)		Intelligent Key warning light (if so equipped)		Front passenger air bag status light
	or  Anti-lock brake warning light		Lane Departure Warning (LDW) system indicator light (Orange; if so equipped)		High beam indicator light (Blue)
	Automatic transmission check warning light		Low fuel warning light		Intelligent Cruise Control system MAIN switch indicator light (Green; if so equipped)
	Preview Function warning light (Orange; if so equipped)		Low tire pressure warning light		Intelligent Cruise Control system set switch indicator light (if so equipped)
	or  Brake warning light		Low washer fluid warning light		Malfunction indicator lamp (MIL)
	Charge warning light		Seat belt warning light		Slip indicator light
	Door open warning light		Supplemental air bag warning light		Snow mode indicator light
	Engine oil pressure warning light		Automatic transmission position indicator light		Turn signal/hazard indicator lights
	P position selecting warning light and chime (if so equipped)		Cruise main switch indicator light (Green)		Vehicle Dynamic Control (VDC) off indicator light
	Intelligent Cruise Control system warning light (Orange; if so equipped)		Cruise set switch indicator light		

## CHECKING BULBS

Apply the parking brake and turn the ignition switch to ON without starting the engine. The following lights will come on:

 , BRAKE OR  ,  ,  ,  ,  
**AWD** , **CRUISE** , **SET**

The following lights come on briefly and then go off:

 , **ABS** , OR  , **SLIP** , **VDC OFF** , **AT CHECK** ,  
 ,  ,  , 

If any light fails to come on, it may indicate a burned-out bulb or an open circuit in the electrical system. Have the system repaired promptly.

## WARNING LIGHTS

### All-Wheel Drive (AWD) warning light (AWD models)

The **AWD** warning light comes on when the ignition switch is turned to ON. It turns off soon after the engine is started.

If the AWD system malfunctions or the revolution, or radius of the front and the rear wheel are different, the warning light will either remain illuminated or blink. See “All-Wheel Drive (AWD)” in the “5. Starting and driving” section.



### CAUTION

- If the warning light comes on while driving there may be a malfunction in the AWD system. Reduce the vehicle speed and have your vehicle checked by an INFINITI dealer as soon as possible.
- If the AWD warning light blinks on when you are driving:
  - **blinks rapidly (about twice a second):** Pull off the road in a safe area, and idle the engine. The driving mode will

change to 2WD to prevent the AWD system from malfunctioning.

If the warning light turns off, you can drive again.

- **blinks slowly (about once every 2 seconds):**

Pull off the road in a safe area, and idle the engine. Check that all tire sizes are the same, tire pressure is correct and tires are not worn.

If the warning light is still on after the above operation, have your vehicle checked by an INFINITI dealer as soon as possible.

 or



### Anti-lock brake warning light

When the ignition switch is turned to the ON position, the anti-lock brake warning light will illuminate and then turn off. This indicates the anti-lock brake system (ABS) is operational.

If the light comes on while the engine is running, it may indicate the anti-lock brake system is not functioning properly. Have the system checked by an INFINITI dealer.

If a malfunction occurs in the system, the anti-lock function of the brake will cease operation but the ordinary brakes will continue to operate. See “Anti-lock brake system (ABS)” in the “5. Starting and driving” section for further details.

**If the light comes on while you are driving, contact an INFINITI dealer for repair.**



### Automatic transmission check warning light

When the ignition switch is turned to the ON position, the automatic transmission check warning light comes on and then turns off. This indicates that the automatic transmission system is operational.

If the light comes on while the engine is running or while driving, it may indicate that the automatic transmission system is not functioning properly. Have an INFINITI dealer check and repair the transmission.

**CRUISE** Preview Function warning light (Orange: if so equipped)

The light comes on if there is a malfunction in the Brake Assist (with Preview Function) system.

**BRAKE** OR  Brake warning light

This light functions for both the parking brake and the foot brake systems.

**Parking brake indicator:**

When the ignition switch is in the ON position, the light comes on when the parking brake is applied.

**Low brake fluid warning light:**

The light warns of a low brake fluid level. If the light comes on while the engine is running with the parking brake not applied, stop the vehicle and perform the following:

1. Check the brake fluid level. Add brake fluid as necessary. See “Brake fluid” in the “8. Maintenance and do-it-yourself” section.

 **WARNING**

- Your brake system may not be working properly if the warning light is on. Driving could be dangerous. If you judge it to be safe, drive carefully to the nearest service station for repairs. Otherwise, have your vehicle towed because driving it could be dangerous.
- Pressing the brake pedal with the engine stopped and/or a low brake fluid level may increase your stopping distance and braking will require greater pedal effort as well as pedal travel.
- If the brake fluid level is below the MINIMUM or MIN mark on the brake fluid reservoir, do not drive until the brake system has been checked at an INFINITI dealer.

2. If the brake fluid level is correct, have the warning system checked by an INFINITI dealer.

**Anti-lock brake system warning indicator**

:

When the parking brake is released and the brake fluid level is sufficient, if both the brake warning light and the anti-lock brake warning light illuminate, it may indicate the anti-lock brake system is not functioning properly. Have the brake system checked by an INFINITI dealer. See “Anti-lock brake warning light” earlier in this section.

 **Charge warning light**

If the light comes on while the engine is running, it may indicate that the charging system is not functioning properly. Turn the engine off and check the alternator belt. If the belt is loose, broken, missing or if the light remains on, see an INFINITI dealer immediately.

 **CAUTION**

**Do not continue driving if the generator belt is loose, broken or missing.**

 **Door open warning light**

This light comes on when any of the doors and/or lift gate are not closed securely while the ignition switch is ON.



### Engine oil pressure warning light

This light warns of low engine oil pressure. If the light flickers or comes on during normal driving, pull off the road in a safe area, stop the engine **immediately** and call an INFINITI dealer or other authorized repair shop.

**The engine oil pressure warning light is not designed to indicate a low oil level. Use the dipstick to check the oil level.** See “Engine oil” in the “8. Maintenance and do-it-yourself” section.



### CAUTION

Running the engine with the engine oil pressure warning light on could cause serious damage to the engine almost immediately. Such damage is not covered by warranty. Turn off the engine as soon as it is safe to do so.Ⓔ



### P position selecting warning light and chime (if so equipped)

The light blinks in red and warning buzzer beeps when the selector lever is not in the P position and you are out with the Intelligent Key.

When the warning light blinks, move the selector lever to P position and return the ignition switch to the LOCK position.



### Intelligent Cruise Control system warning light (Orange; if so equipped)

The light comes on if there is a malfunction in the Intelligent Cruise Control system.



### Intelligent Key warning light (if so equipped)

This light comes on in green when it is possible to turn the ignition switch.

When the light comes on in red, it is not possible to turn the knob.

- The warning light blinks in red when the Intelligent Key is outside the vehicle with the ignition switch in the ACC or ON position. Confirm the location of the

key as soon as possible when the warning light blinks in red.

Be sure to carry the Intelligent Key with you while driving the vehicle.

- The warning light goes off about 10 seconds after the Intelligent Key is brought inside the vehicle.



### Lane Departure Warning (LDW) system indicator light (Orange; if so equipped)

The light will blink if the vehicle is traveling close to either the left or the right of the traveling lane.

The light illuminates if there is a malfunction in the Lane Departure Warning (LDW) system. See “Lane Departure Warning (LDW) system” in the “5. Starting and driving” section.



### Low fuel warning light

This light comes on when the fuel in the tank is getting low. Refuel as soon as it is convenient, preferably before the fuel gauge reaches E.

**There will be a small reserve of fuel remaining in the tank when the fuel gauge needle reaches E.**



## Low tire pressure warning light

Your vehicle is equipped with a tire pressure monitoring system (TPMS) that monitors the tire pressure of all tires except the spare.

The low tire pressure warning light warns of low tire pressure or indicates that the TPMS is not functioning properly.

After the ignition switch is turned ON, this light illuminates for about 1 second and turns off.

### **Low tire pressure warning (for models without run-flat tire only):**

If the vehicle is being driven with low tire pressure, the warning light will illuminate. If you select the tire pressure information in the display, the FLAT TIRE warning message will be displayed. The tire pressure for each tire will also be displayed.

When the low tire pressure warning light illuminates, you should stop and adjust the tire pressure to the recommended COLD tire pressure shown on the Tire and Loading Information label to turn the light OFF.

For additional information, see “Tire pressure monitoring system (TPMS)” in the “5.

Starting and driving” section and the “6. In case of emergency” section.

### **Low tire pressure warning (for models with run-flat tire only):**

If the vehicle is being driven with low tire pressure, the warning light will illuminate. If you select the tire pressure information in the display, the FLAT TIRE warning message will be displayed. The tire pressure for each tire will also be displayed.

When the low tire pressure warning light illuminates, you should stop and adjust the tire pressure to the recommended COLD tire pressure shown on the Tire and Loading Information label to turn the light OFF.

### **Flat tire warning (for models with run-flat tire only):**

If the vehicle is being driven with one or more flat tires, the warning light will flash continuously and a chime will sound for 10 seconds.

The chime will only sound at the first indication of a flat tire and the warning light will flash continuously. When the Flat tire warning is activated, have the system reset and the tire checked and replaced if necessary by an INFINITI dealer. Even if the tire

is inflated to the specified COLD tire pressure, the warning light will continue to flash until the system is reset by an INFINITI dealer.

If you select the tire pressure information in the display, the FLAT TIRE warning message will be displayed. The tire pressure for each tire will also be displayed.

Your vehicle can be driven for a limited time on a flat tire. See “Run-flat tires” in the “8. Maintenance and do-it-yourself” section.

For additional information, see “Tire pressure monitoring system (TPMS)” in the “5. Starting and driving” section and in the “6. In case of emergency” section.

### **TPMS malfunction:**

If the TPMS is not functioning properly, the low tire pressure warning light will flash for approximately 1 minute when the ignition switch is turned ON. The light will remain on after the 1 minute. Have the system checked by an INFINITI dealer.

For additional information, see “Tire pressure monitoring system (TPMS)” in the “5. Starting and driving” section.



## WARNING

- If the light does not illuminate with the ignition switch turned ON, have the vehicle checked by an INFINITI dealer as soon as possible.
- If the light illuminates while driving, avoid sudden steering maneuvers or abrupt braking, reduce vehicle speed, pull off the road to a safe location and stop the vehicle as soon as possible. Serious vehicle damage could occur and may lead to an accident and could result in serious personal injury. Check the tire pressure for all four tires. Adjust the tire pressure to the recommended COLD tire pressure shown on the Tire and Loading Information label to turn the low tire pressure warning light OFF. If the light still comes on while driving after adjusting the tire pressure, a tire may be flat. If you have a flat tire, replace it with a spare tire as soon as possible.
- Although you can continue driving with a punctured run-flat tire (if so equipped),

remember that vehicle handling stability is reduced, which could lead to an accident and personal injury. Also, driving a long distance at high speeds may damage the tires.

- Do not drive at speeds above 55 MPH (88 km/h) and do not drive more than 50 miles (80 km) with a punctured run-flat tire (if so equipped). The actual distance the vehicle can be driven on a flat tire depends on outside temperature, vehicle load, road conditions and other factors.
- Do not tow a trailer when a run-flat tire (if so equipped) is flat.
- When a spare tire is mounted or a wheel is replaced, tire pressure will not be indicated, the TPMS will not function and the low tire pressure warning light will flash. Contact your INFINITI dealer as soon as possible for tire replacement and/or system resetting.
- Replacing tires with those not originally specified by INFINITI could affect the proper operation of the TPMS.



## CAUTION

- The TPMS is not a substitute for the regular tire pressure check. Be sure to check the tire pressure regularly.
- If the vehicle is being driven at speeds of less than 16 MPH (25 km/h), the TPMS may not operate correctly.
- Be sure to install the specified size of tires to the 4 wheels correctly.



### Low washer fluid warning light

This light comes on when the washer fluid is at a low level. Add washer fluid as necessary. See “Window washer fluid” in the “8. Maintenance and do-it-yourself” section.



### Seat belt warning light and chime

The light and chime remind you to fasten seat belts. The light illuminates whenever the ignition switch is turned to ON, and will remain illuminated until the driver's seat belt is fastened. At the same time, the

chime will sound for about 6 seconds unless the driver's seat belt is securely fastened.

The seat belt warning light for the front passenger will illuminate if the seat belt is not fastened when the front passenger's seat is occupied (if so equipped). For 5 seconds after the ignition switch is in the ON position, the system does not activate the warning light for the front passenger.

See "Seat belts" in the "1. Safety — Seats, seat belts and supplemental restraint system" section for precautions on seat belt usage.



### Supplemental air bag warning light

After turning the ignition switch to the ON position, the supplemental air bag warning light will illuminate. The supplemental air bag warning light will turn off after about 7 seconds if the system is operational.

If any of the following conditions occur, the supplemental front air bag, supplemental side air bag and curtain side-impact air bag systems, and pre-tensioner seat belt need servicing and your vehicle must be taken to an INFINITI dealer.

- The supplemental air bag warning light remains on after approximately 7 seconds.
- The supplemental air bag warning light flashes intermittently.
- The supplemental air bag warning light does not come on at all.

Unless checked and repaired, the Supplemental Restraint Systems and/or the pre-tensioner seat belt may not function properly. For additional information, see "Supplemental restraint system" in the "1. Safety — Seats, seat belts and supplemental restraint system" section.



### WARNING

**If the supplemental air bag warning light is on, it could mean that the supplemental front air bag, supplemental side air bag, curtain side-impact air bag systems and/or pre-tensioner seat belt systems will not operate in an accident. To help avoid injury to yourself or others, have your vehicle checked by an INFINITI dealer as soon as possible.**

## INDICATOR LIGHTS



### Automatic transmission position indicator light

When the ignition switch is turned to the ON position, the indicator in the tachometer shows the automatic transmission selector lever position. See "Driving with automatic transmission" in the "5. Starting and driving" section.



### Cruise main switch indicator light (Green)

The light comes on when the cruise control is pushed. The light goes out when the main switch is pushed again. While the cruise control system main switch indicator light is on, the cruise control system is operational.



### Cruise set switch indicator light

The light comes on while the vehicle speed is controlled by the cruise control system. If the light blinks while the engine is running, it may indicate the cruise control system is not functioning properly. Have the system checked by an INFINITI dealer.



## Front passenger air bag status light

The front passenger air bag status light (PASS AIR BAG OFF ) will be lit and the passenger front air bag will be OFF depending on how the front passenger seat is being used.

For front passenger air bag status light operation, see “INFINITI advanced air bag system” in the “1. Safety — Seats, seat belts and supplemental restraint system” section of this manual.



## High beam indicator light (Blue)

This light comes on when the headlight high beam is on and goes out when the low beam is selected.



## Intelligent Cruise Control system MAIN switch indicator light (Green; if so equipped)

The light comes on when the ICC system MAIN switch is pushed. The light goes out when the MAIN switch is pushed again. While the MAIN switch indicator light comes on, the ICC system is operational.



## Intelligent Cruise Control system set switch indicator light (if so equipped)

The light comes on while the vehicle speed is controlled by the Intelligent Cruise Control system. If the light blinks while the engine is running, it may indicate the Intelligent Cruise Control system is not functioning properly. Have the system checked by an INFINITI dealer.



## Malfunction indicator lamp (MIL)

If the malfunction indicator lamp comes on steady or blinks while the engine is running, it may indicate a potential emission control malfunction.

The malfunction indicator lamp may also come on steady if the fuel-filler cap is loose or missing, or if the vehicle runs out of fuel. Check to make sure the fuel-filler cap is installed and closed tightly, and that the vehicle has at least three gallons of fuel in the fuel tank.



After a few driving trips, the  lamp should turn off if no other potential emission control system malfunction exists.

If this indicator lamp comes on steady for 20 seconds and then blinks for 10 seconds when

the engine is not running, it indicates that the vehicle is not ready for an emission control system inspection/maintenance test. See “Readiness for inspection/maintenance (I/M) test” in the “9. Technical and consumer information” section of this manual.

### Operation

The malfunction indicator lamp will come on in one of two ways:

- Malfunction indicator lamp on steady — An emission control system malfunction has been detected. Check the fuel-filler cap. If the fuel-filler cap is loose or missing, tighten or install the cap and continue to drive the vehicle. The  lamp should turn off after a few driving trips. If the  lamp does not turn off after a few driving trips, have the vehicle inspected by an INFINITI dealer. You do not need to have your vehicle towed to the dealer.
- Malfunction indicator lamp blinking — An engine misfire has been detected which may damage the emission control system. To reduce or avoid emission control system damage:

- Do not drive at speeds above 45 MPH (72 km/h).



- b) Avoid hard acceleration or deceleration.
- c) Avoid steep uphill grades.
- d) If possible, reduce the amount of cargo being hauled or towed.

The malfunction indicator lamp may stop blinking and come on steady.

Have the vehicle inspected by an INFINITI dealer. You do not need to have your vehicle towed to the dealer.



## CAUTION

**Continued vehicle operation without having the emission control system checked and repaired as necessary could lead to poor drivability, reduced fuel economy, and possible damage to the emission control system.**

## SLIP Slip indicator light

This indicator will blink when the VDC system or the traction control system is operating, thus alerting the driver to the fact that the road surface is slippery and the vehicle is nearing its traction limits.

## SNOW Snow mode switch indicator light

When selecting SNOW mode while the engine is running, this light will illuminate. See “Snow mode switch” in the “2. Instruments and controls” section.



## Turn signal/hazard indicator lights

The light flashes when the turn signal switch lever or hazard switch is turned on.



## Vehicle Dynamic Control (VDC) off indicator light

The light comes on when the vehicle dynamic control (VDC) off switch is pushed to OFF. This indicates the VDC system and traction control system are not operating. When the VDC off indicator light and slip indicator light come on with the VDC system turned on, this light alerts the driver to the fact that the VDC system’s fail-safe mode is operating, i.e. the VDC system may not be functioning properly. Have the system checked by an INFINITI dealer. If a malfunction occurs in the system, the VDC system function will be canceled but the vehicle is still driveable. For additional information, see “Vehicle dynamic control (VDC)

system” in the “5. Starting and driving” section of this manual.

## AUDIBLE REMINDERS

### Key reminder chime

The chime will sound if the driver’s side door is opened while the key is left in the ignition switch (ignition switch is turned off). Remove the key and take it with you when leaving the vehicle.

### Light reminder chime

The headlights will turn off when the front door is opened with the light switch on unless the ignition switch is in the ON position, or in the case of a model with the Intelligent Key, when the ignition switch is not in the LOCK position.

When you turn the headlight switch ON again after the lights automatically turn off and when you open the driver’s door, the lights will not turn off automatically and a chime will sound instead. See the battery saver system under “Headlight switch” in this section for details. Make sure to turn the light switch off when you leave the vehicle.

## SECURITY SYSTEMS

### Brake pad wear warning

The disc brake pads have audible wear warnings. When a brake pad requires replacement, it will make a high pitched scraping sound when the vehicle is in motion whether or not the brake pedal is depressed. Have the brakes checked as soon as possible if the warning sound is heard.

### Lane Departure Warning (LDW) chime (if so equipped)

If the vehicle is traveling close to either the left or the right of a traveling lane with detectable lane markers, the LDW system will blink the LDW indicator light and a chime sound.

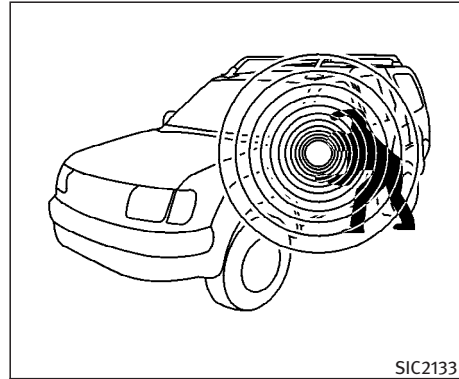

Your vehicle has two types of security systems:

- Vehicle security system
- INFINITI Vehicle Immobilizer System

The condition of the security indicator light shows the status of the Vehicle Security System and the INFINITI Vehicle Immobilizer System.

### VEHICLE SECURITY SYSTEM

The vehicle security system provides visual and audio alarm signals if someone opens the doors, hood, or lift gate when the

system is armed. It is not, however, a motion detection type system that activates when a vehicle is moved or when a vibration occurs.

The system helps deter vehicle theft but cannot prevent it, nor can it prevent the theft of interior or exterior vehicle components in all situations. Always secure your vehicle even if parking for a brief period. Never leave your keys in the vehicle, and always lock the vehicle when unattended. Be aware of your surroundings, and park in secure, well-lit areas whenever possible.

Many devices offering additional protection, such as component locks, identification markers, and tracking systems, are available at auto supply stores and specialty shops. Your INFINITI dealer may also offer such equipment. Check with your insurance company to see if you may be eligible for discounts for various theft protection features.

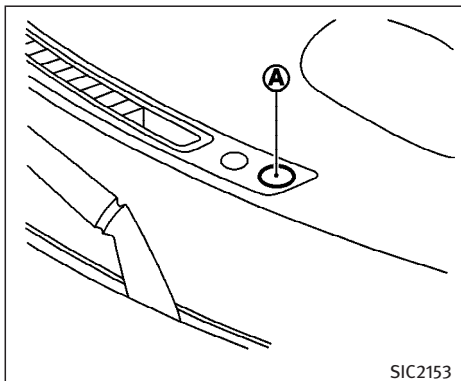

## How to arm the vehicle security system

1. Close all windows.

**The system can be armed even if the windows are open.**

2. Remove the key from the ignition switch.
3. Close and lock all doors and the hood.

Lock all doors by pushing the lock button on the keyfob, Intelligent Key or the front door handle request switch or by using the key.

When using the remote keyless entry, the hazard indicators will operate as shown in “Remote keyless entry system” or “Intelligent Key system” in the “3. Pre-driving checks and adjustments” section.

4. Confirm that the SECURITY indicator light (A) comes on. The SECURITY indicator light (A) glows for about 30 seconds and then blinks. The system is now activated. If, during this 30 second time period, the door is unlocked by the key or the remote keyless entry, or the ignition key is turned to ACC or ON, the system will not be armed.

**Even when the driver and/or passengers are in the vehicle, the system will activate with all doors and the hood locked and ignition key off. Turn the ignition key to ACC to turn the system off.**

## Vehicle security system activation

The security system will give the following alarm:

- The headlights blink and the horn sounds intermittently.
- The alarm automatically turns off after approximately 1 minute. However, the alarm reactivates if the vehicle is tampered with again. The alarm can be shut off by unlocking a door with the key, or by pressing the UNLOCK button on the electronic ignition key.

The alarm is activated by:

- Opening the door without using the key or remote keyless entry.
- Opening the lift gate without using the key or remote keyless entry.
- Opening the hood.

## How to stop an activated alarm

The alarm will stop only by unlocking a door with the key, by pressing the door handle request switch or by pressing the UNLOCK button on the keyfob or Intelligent Key. The alarm will not stop if the ignition switch is turned to ACC or ON.

If the system does not operate as described above, have it checked by an INFINITI dealer.

## INFINITI VEHICLE IMMOBILIZER SYSTEM

The INFINITI Vehicle Immobilizer System will not allow the engine to start without the use of the registered key.

If the engine fails to start using the registered key (for example, when interference is caused by another registered key, an automated toll road device or automated payment device on the key ring), restart the engine using the following procedures:

1. Leave the ignition switch in the ON position for approximately 5 seconds.
2. Turn the ignition switch to the OFF or LOCK position and wait approximately 10 seconds.
3. Repeat step 1 and 2.
4. Restart the engine while holding the device (which may have caused the interference) separate from the registered key.

If this procedure allows the engine to start, INFINITI recommends placing the registered key on a separate key ring to avoid interference from other devices.

**Statement related to section 15 of FCC rules for INFINITI Vehicle Immobilizer System (CONT ASSY-BCM, ANT ASSY-IMMOBILISER)**

**This device complies with part 15 of the FCC Rules and RSS-210 of Industry Canada. Operation is subject to the following two conditions;**

**(1) This device may not cause harmful interference, and (2) this device must accept any interference received, including interference that may cause undesired operation of the device.**

**CHANGES OR MODIFICATIONS NOT EXPRESSLY APPROVED BY THE PARTY RESPONSIBLE FOR COMPLIANCE COULD VOID THE USER'S AUTHORITY TO OPERATE THE EQUIPMENT.**

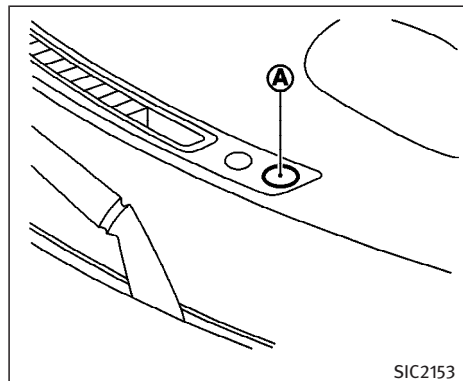

### Security indicator light

The security indicator light (A) blinks whenever the ignition key is removed for 5 seconds after the ignition switch is in the OFF position (mechanical key) or the ignition switch is in the LOCK position (Intelligent Key). This function indicates the security systems equipped on the vehicle are operational.

If a non-registered key is in the ignition switch, the indicator light comes on.

## WINDSHIELD WIPER AND WASHER SWITCH

If INFINITI Vehicle Immobilizer System is malfunctioning, this light will remain on while the ignition switch is in the ON position.

If the light still remains on and/or the engine will not start, see an INFINITI dealer for INFINITI Vehicle Immobilizer System service as soon as possible. Please bring all electronic ignition keys that you have when visiting an INFINITI dealer for service.

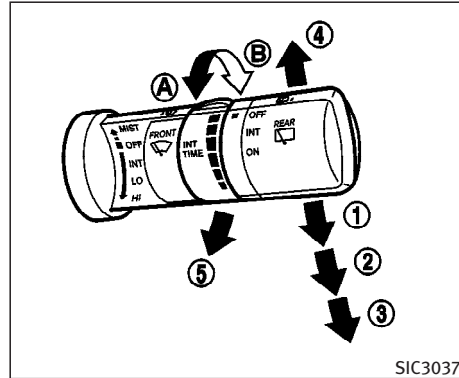

The windshield wiper and washer operates when the ignition switch is in the ON position.

Push the lever down to operate the wiper at the following speed:

- ① Intermittent (INT) — intermittent operation can be adjusted by turning the knob toward **A** (Slower) or **B** (Faster). Also, the intermittent operation speed varies in accordance with the vehicle speed. (For example, when the vehicle speed is high, the intermittent operation speed will be faster.) You can switch this function on and off manu-

ally. See “How to use the SETTING button” in the “4. Display screen, heater, air conditioner and audio systems” section.

- ② Low (LO) — continuous low speed operation
- ③ High (HI) — continuous high speed operation

Push the lever up **④** to have one sweep operation (MIST) of the wiper.

Pull the lever toward you **⑤** to operate the washer. Then the wiper will also operate several times.



### WARNING

In freezing temperatures the washer solution may freeze on the windshield and obscure your vision which may lead to an accident. Warm the windshield with the defroster before you wash the windshield.

## CAUTION

- Do not operate the washer continuously for more than 30 seconds.
- Do not operate the washer if the reservoir tank is empty.
- Do not fill the window washer reservoir tank with washer fluid concentrates at full strength. Some methyl alcohol based washer fluid concentrates may permanently stain the grille if spilled while filling the window washer reservoir tank.
- Pre-mix washer fluid concentrates with water to the manufacturer's recommended levels before pouring the fluid into the window washer reservoir tank. Do not use the window washer reservoir tank to mix the washer fluid concentrate and water.

## REAR WINDOW WIPER AND WASHER SWITCH

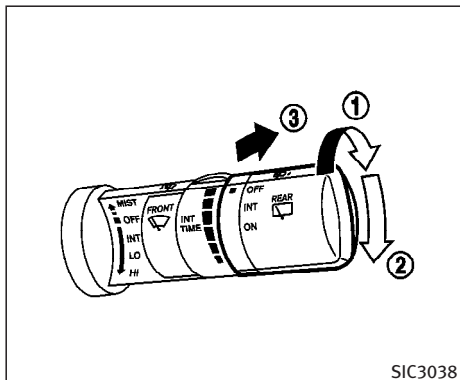

The rear window wiper and washer operate when the ignition switch is in the ON position.

Turn the switch clockwise from the OFF position to operate the wiper.

- ① Intermittent (INT) — intermittent operation (not adjustable)
- ② Low (ON) — continuous low speed operation

Push the switch forward ③ to operate the washer. Then the wiper will also operate several times.

## WARNING

In freezing temperatures the washer solution may freeze on the window and obscure your vision. Warm the rear window with the defroster before you wash the rear window.

## CAUTION

- If the rear window wiper operation is interrupted by snow etc., the wiper may stop moving to protect its motor. If this occurs, turn the wiper switch to OFF and remove the snow etc. on and around the wiper arms. After about 1 minute, turn the switch ON again to operate the wiper.
- Do not operate the washer continuously for more than 30 seconds.
- Do not operate the washer if reservoir tank is empty.
- Do not fill the window washer reservoir tank with washer fluid concentrates at full strength. Some methyl alcohol based

washer fluid concentrates may permanently stain the grille if spilled while filling the window washer reservoir tank.

- Pre-mix washer fluid concentrates with water to the manufacturer's recommended levels before pouring the fluid into the window washer reservoir tank. Do not use the window washer reservoir tank to mix the washer fluid concentrate and water.

## REAR WINDOW AND OUTSIDE MIRROR DEFROSTER SWITCH

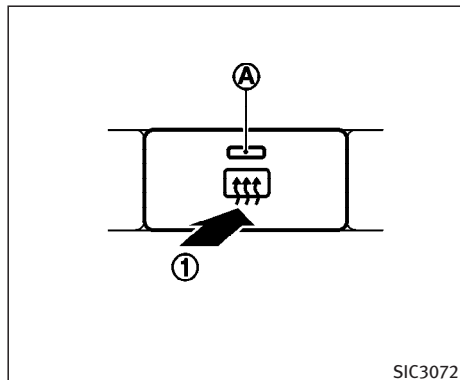

To defog/defrost the rear window glass and outside mirrors, start the engine and push the switch on ①. The indicator light Ⓐ will come on. Push the switch again to turn the defroster off.

It will automatically turn off in approximately 15 minutes.



### CAUTION

When cleaning the inner side of the rear window, be careful not to scratch or damage the rear window defroster.

## HEADLIGHT AND TURN SIGNAL SWITCH

### XENON HEADLIGHTS



### WARNING



### HIGH VOLTAGE

- When xenon headlights are on, they produce a high voltage. To prevent an electric shock, never attempt to modify or disassemble. Always have your xenon headlights replaced at an INFINITI dealer.
- Xenon headlights provide considerably more light than conventional headlights. If they are not correctly aimed, they might temporarily blind an oncoming driver or the driver ahead of you and cause a serious accident. If headlights are not aimed correctly, immediately take your vehicle to an INFINITI dealer and have the headlights adjusted correctly.

When the xenon headlight is initially turned on, its brightness or color varies slightly. However, the color and brightness will soon stabilize.

- The life of xenon headlights will be shortened by frequent on-off operation. It is generally desirable not to turn off the headlights for short intervals (for example, when the vehicle stops at a traffic signal). Even when the daytime running lights are active (Canada only), the xenon headlights do not turn on. This way the life of the xenon headlights is not reduced.
- If the xenon headlight bulb is close to burning out, the brightness will drastically decrease, the light will start blinking, or the color of the light will become reddish. If one or more of the above signs appear, contact an INFINITI dealer.

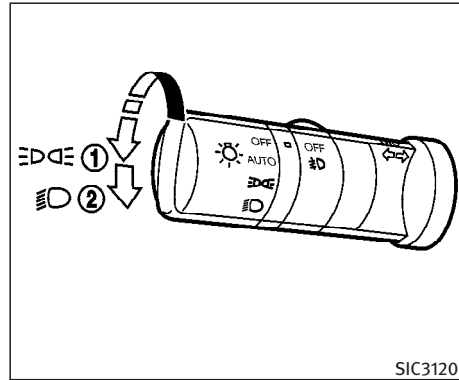



SIC3120

Type A

## HEADLIGHT SWITCH

### Lighting

- ① Turn the switch to the  position:  
The front park, side marker, tail, license plate and instrument lights will come on.
- ② Turn the switch to the  position:  
Headlights will come on and all the other lights remain on.

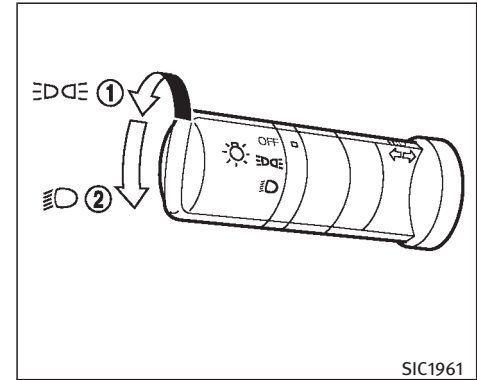

SIC1961

Type B



## CAUTION

Use the headlights with the engine running to avoid discharging the vehicle battery.



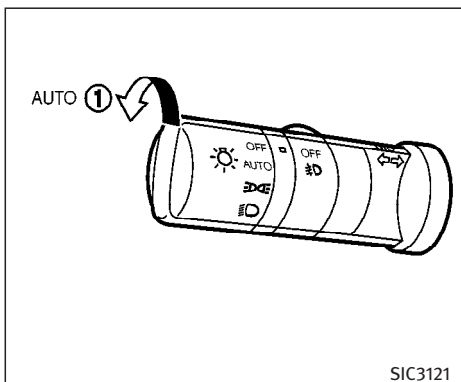

The autolight system can turn on the headlights automatically when it is dark, turn off the headlights when it is light, and keep the headlights on for up to 45 seconds after you turn the switch to OFF and open any door then close all the doors.



If the ignition switch is turned OFF and one of the doors is opened and this condition is continued, the headlights remain ON for 5 minutes.

### Autolight system (if so equipped)

The autolight system allows the headlights to be set so they turn on and off automatically.

To set the autolight system:

1. Make sure the headlight switch is in the AUTO position.
2. Turn the ignition switch to ON.
3. The autolight system automatically turns the headlights on and off.

To turn the autolight system off, turn the switch to the OFF, , or  position.

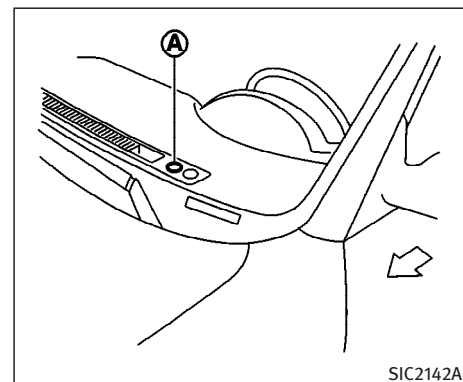

**Be sure not to put anything on top of the photo sensor  located on the top left-hand side of the instrument panel. The photo sensor controls the autolight; if it is covered, the photo sensor reacts as if it is dark and the headlights will illuminate.**

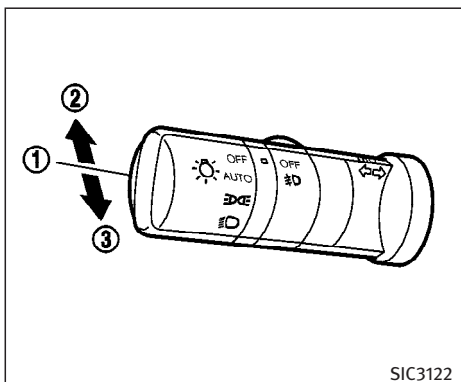

## Headlight beam select

- ① To select the low beam, put the lever in the neutral position as shown.
- ② To select the high beam, push the lever forward.
- ③ Pulling the lever toward you will flash the headlight high beam.

## Battery saver system

- When the headlight switch is in the or position while the ignition switch is in the ON position, the lights will automatically turn off 5 minutes after the ignition switch has been turned to the OFF position.
- When the headlight switch remains in the or position after the lights automatically turn off, the lights will turn on for 5 minutes when the headlight switch is turned to the OFF position and then turn to the or position.



## CAUTION

**Even though the battery saver feature automatically turns off the headlights after a period of time, you should turn the headlight switch to the OFF position when the engine is not running to avoid discharging the battery.**

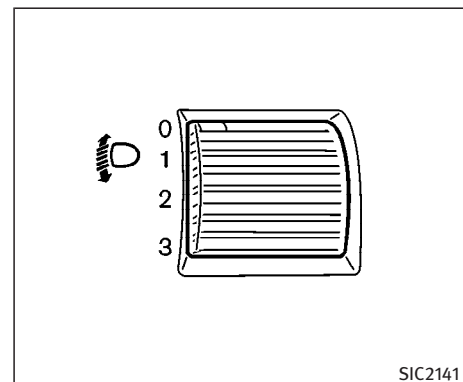

## Headlight aiming control

Depending on the number of occupants in the vehicle and the load it is carrying, the headlight axis may be higher than desired. If the vehicle is traveling on a hilly road, the headlights may directly hit the rearview mirror of the vehicle ahead or the windshield of the oncoming vehicle. The light axis can be lowered with the operation of the switch.

The larger the number designated on the switch, the lower the axis.

When traveling with no heavy load or on a flat road, select position 0.



## WARNING

Xenon headlights are extremely bright compared to conventional headlights. If the xenon headlights hit the rearview mirror of the vehicle ahead or the windshield of the oncoming vehicle, the driver of these vehicles may have difficulty driving because of the brightness. Use the headlight aiming control switch to lower the light axis. See “Xenon headlights” earlier in this section for additional information.

## DAYTIME RUNNING LIGHT SYSTEM (CANADA ONLY)

The daytime running lights automatically illuminate when the engine is started with the parking brake released. The daytime running lights operate with the headlight switch in the OFF position or in the  $\text{D}$  position.

If the parking brake is applied before the engine is started, the daytime running lights do not illuminate. The daytime run-

ning lights illuminate once the parking brake is released. The daytime running lights will remain on until the ignition switch is turned off.

The daytime running light may come on after turning the key to the OFF position and immediately turning it to the ON position. This is not a malfunction.

The daytime running light will be turned off when the headlight switch is turned to the AUTO or  $\text{D}$  position.

The daytime running light will remain on until the ignition switch is turned to the ACC or OFF position.

Turn the fog light switch to the  $\text{D}$  position to turn the fog light ON when driving at night if necessary.



## WARNING

**When the daytime running light system is active, tail lights on your vehicle are not on. It is necessary at dusk to turn on your headlights. Failure to do so could cause an accident injuring yourself and others.**

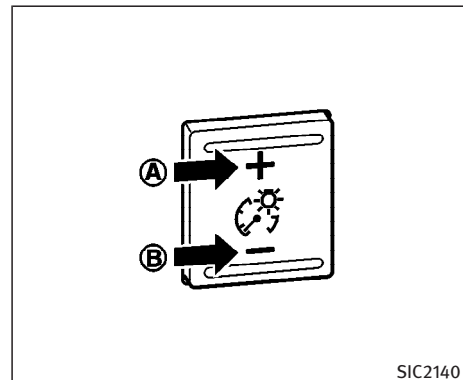

## INSTRUMENT BRIGHTNESS CONTROL

The instrument brightness control operates when the light switch is in the  $\text{D}$  or  $\text{D}$  position.

To adjust the brightness of instrument panel lights, press the control switches located on the left side of the meter panel. Pressing the upper switch (A) will brighten the lights. The lower switch (B) dims the lights. Repeatedly pressing the lower switch will turn the lights off.

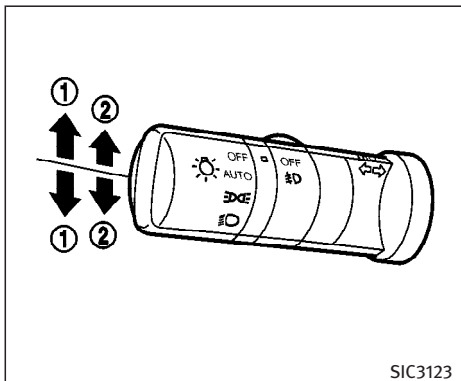

SIC3123

## TURN SIGNAL SWITCH

### ① Turn signal

Move the lever up or down to signal the turning direction. When the turn is completed, the turn signals cancel automatically.

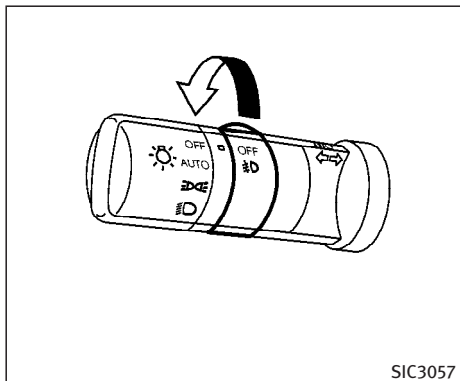

### ② Lane change signal

To indicate a lane change, move the lever up or down to the point where lights begin flashing.



SIC3057

## FOG LIGHT SWITCH

To turn the fog lights on, turn the headlight switch to the  position, then turn the switch to the  position. To turn them off, turn the switch to the OFF position.

The headlights must be on and the low beams selected for the fog lights to operate. The fog lights automatically turn off when the high beam headlights are selected.

## HAZARD WARNING FLASHER SWITCH

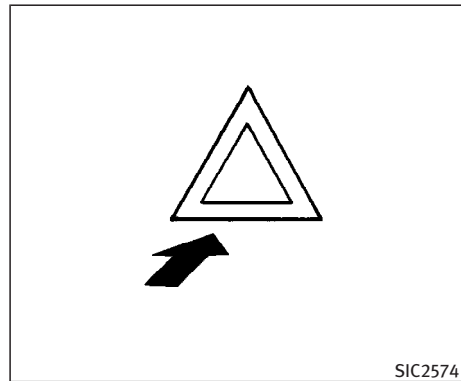

SIC2574

Push the switch on to warn other drivers when you must stop or park under emergency conditions. All turn signal lights will flash.

**Some state laws may prohibit the use of the hazard warning flasher switch while driving.**



## WARNING

- If stopping for an emergency, be sure to move the vehicle well off the road.

- Do not use the hazard warning flashers while moving on the highway unless unusual circumstances force you to drive so slowly that your vehicle might become a hazard to other traffic.
- Turn signals do not work when the hazard warning flasher lights are on.

The flasher can be actuated with the ignition switch either off or on.

## HORN

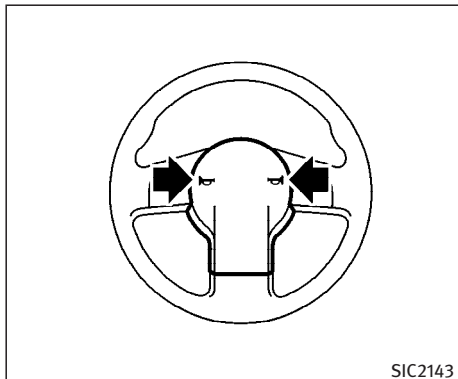

To sound the horn, push around the horn marks of the steering wheel.





### WARNING

Do not disassemble the horn. Doing so could affect proper operation of the supplemental front air bag system. Tampering with the supplemental front air bag system may result in serious personal injury.

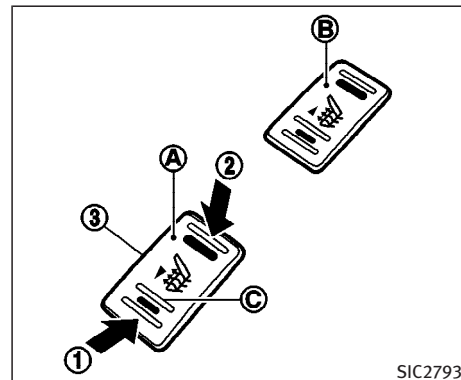
## HEATED SEATS (if so equipped)



The front seats are warmed by built-in heaters. The switches located on the center console can be operated independently (driver side seat **A** and front passenger seat **B**) of each other.

1. Start the engine.
2. Select heat range.
  - ① For low heat, push the  (Low) side of the switch.
  - ② For high heat, push the  (High) side of the switch.
  - ③ For no heat, the switch has a center OFF position between low and high.

The indicator light in the switch ③ will illuminate when low or high is selected.

The heater is controlled by a thermostat, automatically turning the heater on and off. The indicator light will remain on as long as the switch is on.

3. When the vehicle's interior is warmed, or before you leave the vehicle, be sure to turn the switch to the off position (center) ③.



## CAUTION

- The battery could run down if the seat heater is operated while the engine is not running.
- Do not use the seat heater for extended periods or when no one is using the seat.
- Do not put anything on the seat which insulates heat, such as a blanket, cushion, seat cover, etc. Otherwise, the seat may become overheated.

- Do not place anything hard or heavy on the seat or pierce it with a pin or similar object. This may result in damage to the heater.
- Any liquid spilled on the heated seat should be removed immediately with a dry cloth.
- When cleaning the seat, never use gasoline, benzene, thinner, or any similar materials.
- If any abnormalities are found or the heated seat does not operate, turn the switch off and have the system checked by an INFINITI dealer.

## LANE DEPARTURE WARNING (LDW) SWITCH (if so equipped)

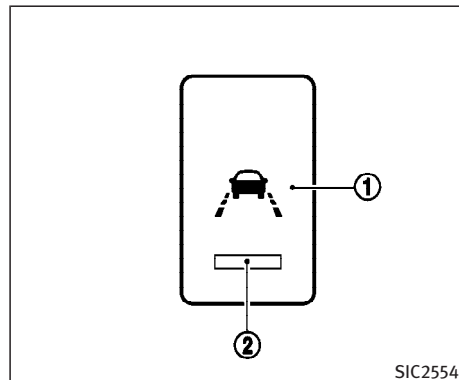

The Lane Departure Warning (LDW) system will blink an indicator light on the instrument panel and sound a chime to alert the driver if the vehicle is traveling close to either the left or the right of the traveling lane.

The system comes on automatically in its automatic mode when the ignition switch is turned on.

To cancel the LDW system, push the LDW switch ① to turn off the system. The LDW system ON indicator ② will go off.

Push the LDW switch again or restart the engine to turn the system on. Modes can be changed to automatic mode or manual mode by pushing and holding the LDW switch for more than 4 seconds while the LDW system ON indicator is off. See “Lane departure warning (LDW) system” in the “5. Starting and driving” section.

### SNOW MODE SWITCH

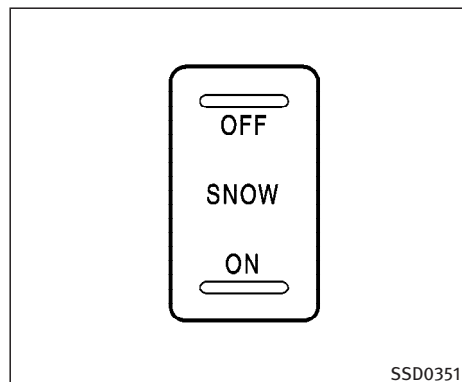

For driving or starting the vehicle on snowy roads or slippery areas, turn on the SNOW mode switch and the SNOW indicator light on the meter panel will illuminate. When the SNOW mode is activated, engine output is controlled to avoid wheel spin.

### VEHICLE DYNAMIC CONTROL (VDC) OFF SWITCH

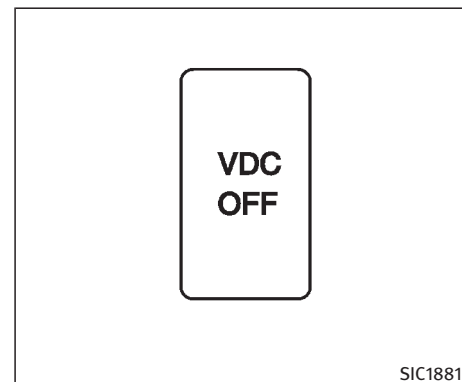

The vehicle should be driven with the Vehicle Dynamic Control (VDC) System on for most driving conditions.

If the vehicle is stuck in mud or snow, the VDC system reduces the engine output to reduce wheel spin. The engine RPM will be reduced even if the accelerator is depressed to the floor. If maximum engine power is needed to free a stuck vehicle, turn the VDC system off.

To turn off the VDC system, push the VDC OFF switch. The <sup>VDC</sup>OFF indicator will come on.

## CLOCK

Push the VDC OFF switch again or restart the engine to turn ON the system. See “Vehicle dynamic control (VDC) system” in the “5. Starting and driving” section.

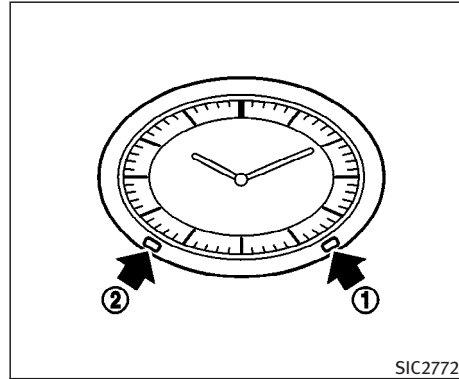

If the power supply is disconnected, the clock will not indicate the correct time. Re-adjust the time.

### ADJUSTING THE TIME

1. To set the clock forward, push the button ①.
2. To set the clock backward, push the button ②.
3. To move forward or backward faster, push and hold the button more than 5 seconds.

## POWER OUTLET



### CAUTION

- The outlet and plug may be hot during or immediately after use.
- This power outlet is not designed for use with a cigarette lighter unit.
- Do not use with accessories that exceed a 12 volt, 120W (10A) power draw. Do not use double adapters or more than one electrical accessory.
- Use power outlets with the engine running to avoid discharging the vehicle battery.
- Avoid using power outlets when the air conditioner, climate controlled seat, headlights or rear window defroster is on.
- Before inserting or disconnecting a plug, be sure to turn off the power switch of the electrical accessory being used or the ACC power of the vehicle.
- Push the plug in as far as it will go. If good contact is not made, the plug may



overheat or the internal temperature fuse may open.

- When not in use, be sure to close the cap. Do not allow water to contact the outlet.

The power outlet is for powering electrical accessories such as cellular telephones.

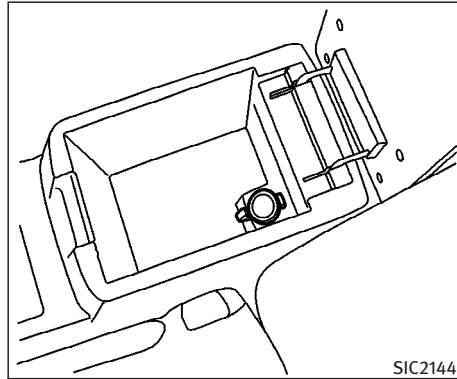

Console

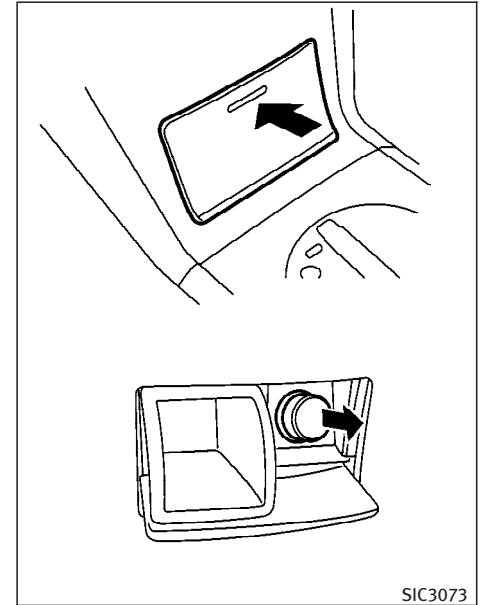

Front

## STORAGE

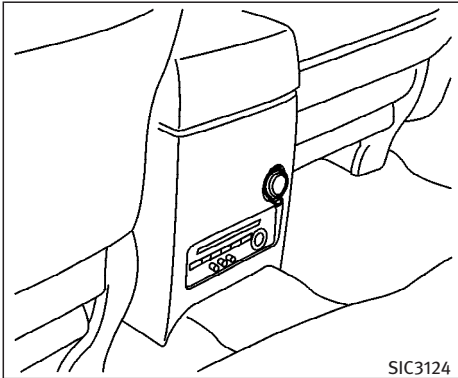

Rear

SIC3124

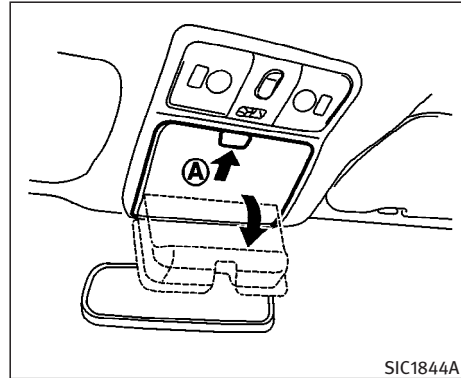

SIC1844A

## SUNGLASSES HOLDER

The sunglasses holder can be opened by pushing the button (A).



## WARNING

- The sunglasses holder should not be used while driving so full attention may be given to vehicle operation.
- Keep the sunglasses holder closed while driving to prevent an accident.

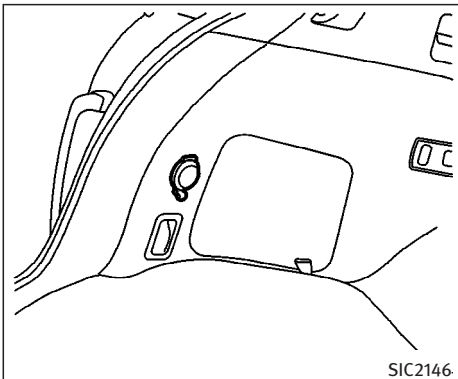

SIC2146

Luggage room



## CAUTION

- Do not use for anything other than sunglasses.
- Do not leave sunglasses in the sunglasses holder while parking in direct sunlight. The heat may damage the sunglasses.

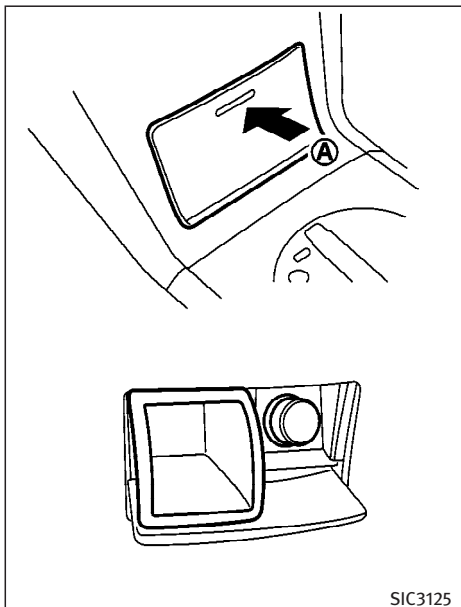

## STORAGE BOX



### WARNING

The storage box should not be used while driving so full attention may be given to vehicle operation.

To open, push the storage box lid **A** as illustrated.

**Do not place valuable items in the storage box.**

**Do not use the storage box as an ashtray.**

## CUP HOLDERS



### WARNING

The cup holder should not be used while driving so full attention may be given to vehicle operation.



### CAUTION

- Avoid abrupt starting and braking when the cup holder is being used to prevent spilling the drink. If the liquid is hot, it can scald you or your passenger.
- Use only soft cups in the cup holder. Hard objects can injure you in an accident.

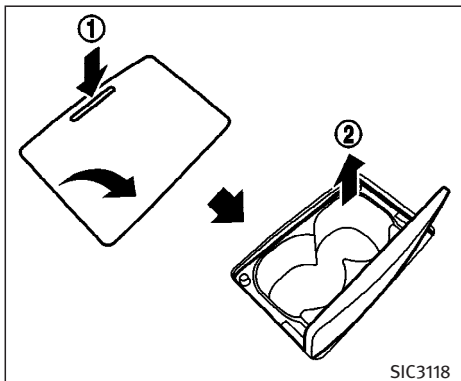

### Front cup holder

To open the cup holder, push the lid ①.

The flap will be folded down when inserting a large container.

To close, lower the cup holder lid and push it down lightly.

To clean the front cup holder, pull up the inside tray ② and remove it.

The cup holder is not designed to store personal effects.

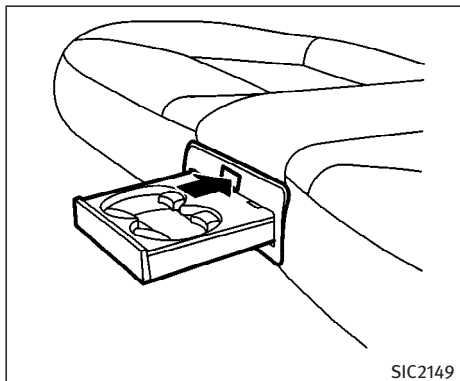

### Rear cup holder

Push the cup holder opener switch to draw out the rear cup holder.

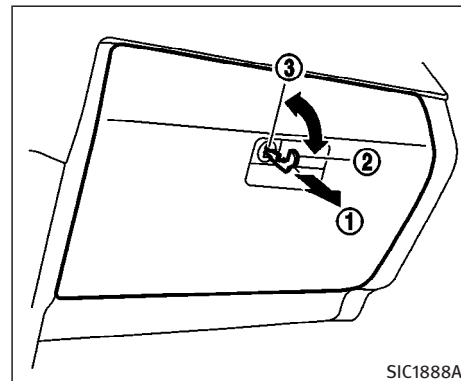

### GLOVE BOX

To open the glove box, pull the handle ①.

To close, push the lid in until the lock latches.

To lock ② or unlock ③ the glove box, use the master key, mechanical key or wallet key.



## **WARNING**

Keep glove box lid closed while driving to help prevent injury in an accident or a sudden stop.

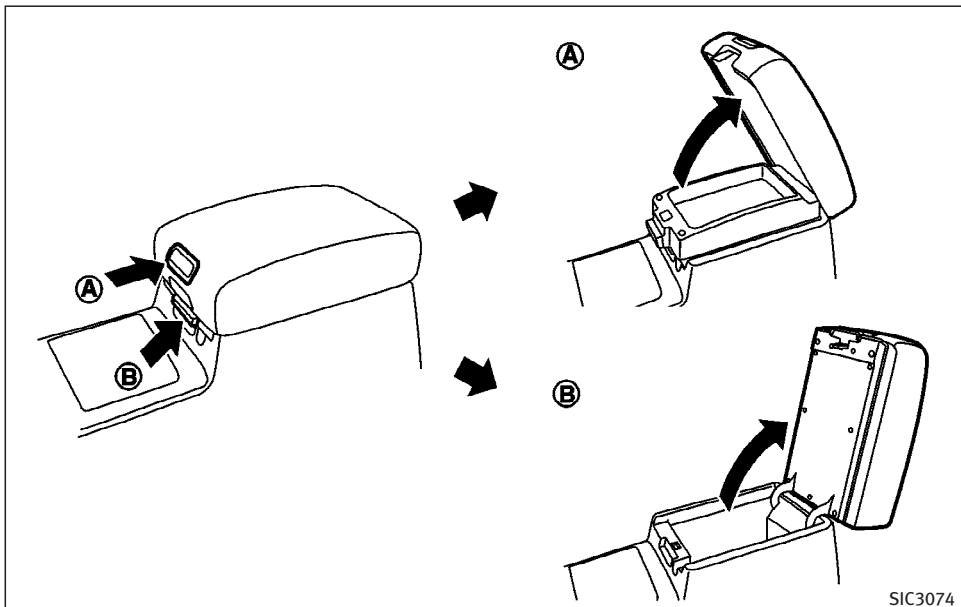

## CONSOLE BOX



### WARNING

The center console box should not be used while driving so full attention may be given to vehicle operation.



### CAUTION

To avoid being pinched, do not place your fingers near the hinge when opening/closing the console box.

When the button **(A)** is pushed, the upper case is available for storing some small items. When the lever **(B)** is pulled, the bottom case is available for storing some larger ones.

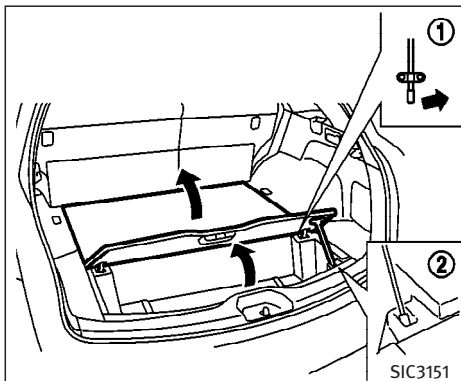

### LUGGAGE FLOOR BOXES (if so equipped)

To open the luggage floor boxes:

1. Raise the luggage box lid.
2. Remove the assist bar (1) and insert it into the slot (2).

To close, reset the assist bar to its original position.

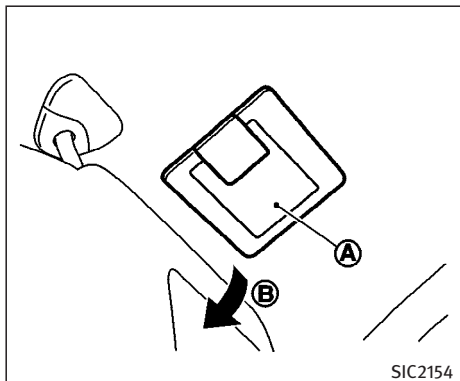

### CARD HOLDER (for driver's side)

To use the card holder, slide your card (A) in after lowering the sun visor (B).

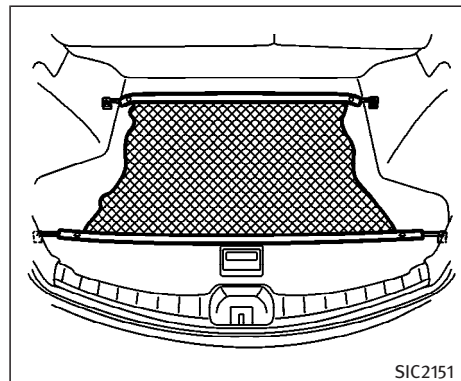

### CARGO NET (if so equipped)

The cargo net helps keep packages in the cargo area from moving around while your vehicle is driven.

To install the cargo net, attach the hooks to the retainers.



### WARNING

- Properly secure all cargo to help prevent it from sliding or shifting. Do not place cargo higher than the seatbacks.

In a sudden stop or collision, unsecured cargo could cause personal injury.

- Be sure to secure all four hooks into the retainers. The cargo restrained in the net must not exceed 30 lb (13.6 kg) or the net may not stay secured.

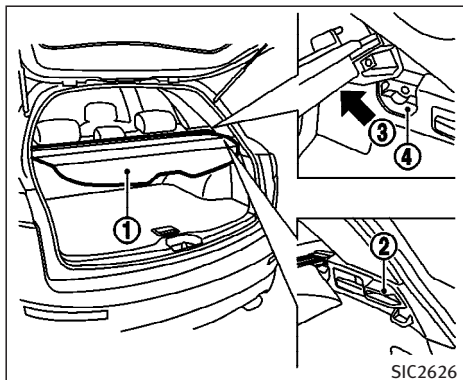

### TONNEAU COVER (if so equipped)

The tonneau cover ① keeps the luggage compartment contents hidden from the outside.

To open the tonneau cover, pull it out and hang both sides on the hooks ②. To close the tonneau cover, remove it from the hooks and then release it as illustrated.

To remove the tonneau cover, pat gently the bottom of the tonneau cover frame ③ upward and remove it from the holder ④ after closing the tonneau cover and folding the rear seatbacks forward.



### WARNING

- Never put anything on the tonneau cover, no matter how small. Any object on it could cause an injury in an accident or sudden stop.
- Do not leave the tonneau cover in the vehicle with it disengaged from the holder.
- Never remove the tonneau cover with the rear seatbacks reclined. The tonneau cover may jump up suddenly and could cause an injury in the removal procedure.
- Properly secure all cargo to help prevent it from sliding or shifting. Do not place cargo higher than the seatbacks. In a sudden stop or collision, unsecured cargo could cause personal injury.
- The child restraint top tether strap may be damaged by contact with the tonneau cover or items in the cargo area. Remove the tonneau cover from the vehicle or secure it and any cargo. Your child could be seriously injured or killed in a collision if the top tether strap is damaged.



## WINDOWS

### POWER WINDOWS



#### WARNING

- Make sure that all passengers have their hands, etc. inside the vehicle while it is in motion and before closing the windows. Use the window lock switch to prevent unexpected use of the power windows.
- Do not leave children unattended inside the vehicle. They could unknowingly activate switches or controls and become trapped in a window. Unattended children could become involved in serious accidents.

The power windows operate when the ignition switch is in the ON position and for about 45 seconds, after the ignition switch is turned to the OFF position. If the driver's door or the front passenger's door is opened during this period of about 45 seconds, power to the windows is canceled.

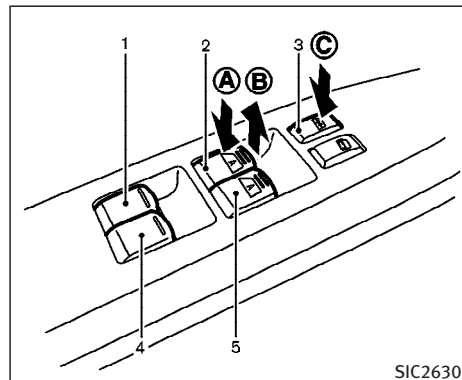

**Main switch**

**Main power window switch  
(driver's side)**

1. Rear left passenger side window
2. Driver side window
3. Window lock button
4. Rear right passenger side window
5. Front passenger side window

To open or close the window, push down **A** or pull up **B** the switch and hold it. The main switch (driver side switches) will open or close all the windows.

## Locking passenger's windows

When the lock button (C) is pushed in, only the driver side window can be opened or closed. Push it in again to cancel.

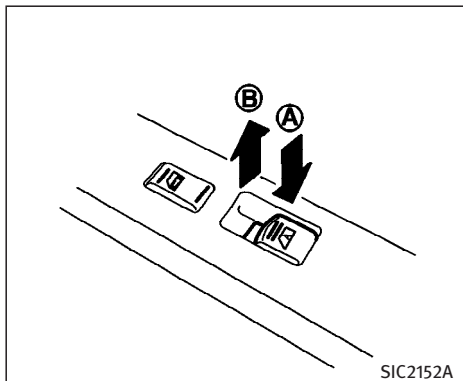

**Passenger side**

### Passenger side power window switch

The passenger side switch will open or close only the corresponding window. To open or close the window, hold the switch down (A) or up (B).

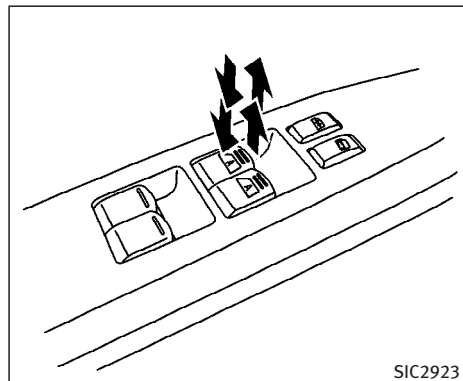

**Main switch**

### Automatic operation (For front door windows)

To fully open or close the window, completely press or lift the switch and release it; it need not be held. The window will automatically open or close all the way. To stop the window, just press or lift the switch on the opposite side.

### Auto reverse function

If the control unit detects something caught in a window as it moves up, the window will be immediately lowered.

The auto reverse function can be activated when a window is closed by automatic operation when the ignition switch is in the ON position or for about 45 seconds after the ignition switch is turned to the ACC, OFF or LOCK position.

**Depending on the environment or driving conditions, the auto reverse function may be activated if an impact or load similar to something being caught in the window occurs.**



## WARNING

There are some small distances immediately before the closed position which cannot be detected. Make sure that all passengers have their hands, etc., inside the vehicle before closing the window.

## SUNROOF (if so equipped)

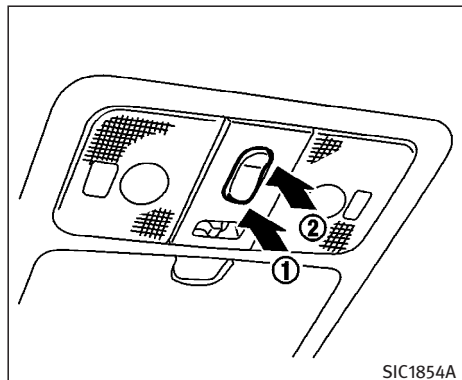

### AUTOMATIC SUNROOF

The sunroof will only operate when the ignition switch is in the ON position.

The automatic sunroof is operational for about 45 seconds, even if the ignition switch is turned to the OFF position. If the driver's door or the front passenger's door is opened during this period of about 45 seconds, power to the sunroof is canceled.

### Sliding the sunroof

To fully open or close the sunroof, press the switch to the CLOSE ① or OPEN ② side for less than 1 second and release it; it

need not be held. The roof will automatically open or close all the way. To stop the roof, press the switch once more while it is opening or closing.

To open or close the sunroof and stop on the way, press the switch to the CLOSE ① or OPEN ② side. The roof will stop when releasing the switch.

### Tilting the sunroof

To tilt up, first close the sunroof, then press the UP ② side of the switch and release it; it need not be held. To tilt down the sunroof, press the DOWN ① side.

### Sun shade

Open or close the sun shade by sliding it backward or forward.

The shade will open automatically when the sunroof is opened. However, it must be closed manually.

### Auto reverse function (When closing or tilting down the sunroof)

The auto reverse function can be activated when the sunroof is closed or tilted down by automatic operation when the ignition key is in the ON position or for about 45

seconds after the ignition key is turned to the OFF position.

**Depending on the environment or driving conditions, the auto reverse function may be activated if an impact or load similar to something being caught in the sunroof occurs.**



## WARNING

There are some small distances immediately before the closed position which cannot be detected. Make sure that all passengers have their hands, etc., inside the vehicle before closing the sunroof.

### When closing:

If the control unit detects something caught in the sunroof as it moves to the front, the sunroof will immediately open backward.

### When tilting down:

If the control unit detects something caught in the sunroof as it tilts down, the sunroof will immediately tilt up.



## WARNING

- In an accident you could be thrown from the vehicle through an open sunroof. Always use seat belts and child restraints.
- Do not allow anyone to stand up or extend any portion of their body out of the sunroof opening while the vehicle is in motion or while the sunroof is closing.



## CAUTION

- Remove water drops, snow, ice or sand from the sunroof before opening.
- Do not place any heavy object on the sunroof or surrounding area.

### If the sunroof does not close

If the sunroof does not close or open automatically, use the following procedure to return sunroof operation to normal.

1. Press the switch to the CLOSE/UP side to tilt up the sunroof.

2. Press and hold the switch to the CLOSE/UP side for approximately 3 seconds while the sunroof is tilted up.
3. Release the switch once, then press and hold the switch to the CLOSE/UP side again for approximately 10 seconds until the sunroof moves automatically.
4. The sunroof will automatically open and then close all the way.

If the sunroof does not operate properly after step 4, repeat the procedure starting with step 1.

If the sunroof still does not close, have an INFINITI dealer check and repair the sunroof.

## INTERIOR LIGHT

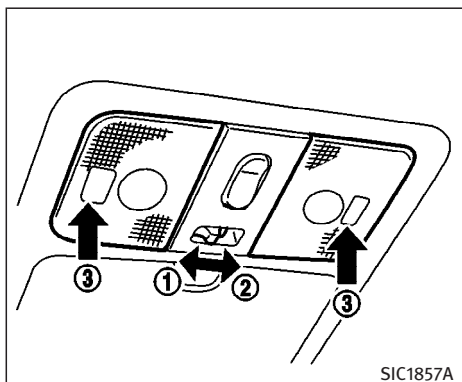

## ROOM LIGHT

The room light has a two-position switch; DOOR ① and OFF ②.

When the switch is in the door position ①, the light will illuminate when a door is opened.

The light will stay on for about 30 seconds when:

- The doors are unlocked by the keyfob, a key, the power door lock switch or using the Intelligent Key system while all doors are closed.

- The driver's door is opened and then closed while the key is removed from the ignition switch.
- The key is removed from the ignition switch while all doors are closed.

The light will turn off while the 30 second timer is activated, when:

- The driver's door is locked either with the keyfob, a key, the power door lock switch or using the Intelligent Key system.
- The ignition switch is turned ON.

## MAP LIGHT

When the switch ③ is pushed in, the light will turn on. When the switch ③ is pushed again, the light will turn off.

**When the map light switch is in the ON position, it will automatically turn off 30 minutes after the ignition switch has been turned to the OFF position. To turn on the light again, turn the ignition switch to the ON position.**

The map, personal, and vanity mirror lights will automatically turn off 30 minutes after the latest operation of the following with the ignition switch in the ACC or OFF position:

- Opening or closing any door
- Locking or unlocking with the keyfob, a key or the power door lock switch.
- Inserting or removing a key from the ignition switch

These lights will turn on again when any of the above operations is performed after the lights have turned off automatically. (The lights will turn off 30 minutes after the latest operation of the above as well.)



## CAUTION

- Turn off the map, personal and vanity mirror lights when you leave the vehicle.
- Do not use for extended periods of time with the engine stopped. This could result in a discharged battery.

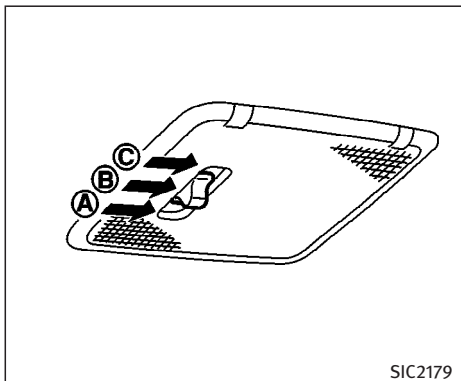

### CEILING LIGHT (if so equipped)

The ceiling light has a three-position switch.

When the switch is in the door position (B), the light will illuminate when the door is opened. Same as the door position of the interior light.

**When the personal light switch is in the ON position (A), it will automatically turn off 30 minutes after the ignition switch has been turned to the OFF position (C). To turn on the light again, turn the ignition switch to the ON position.**

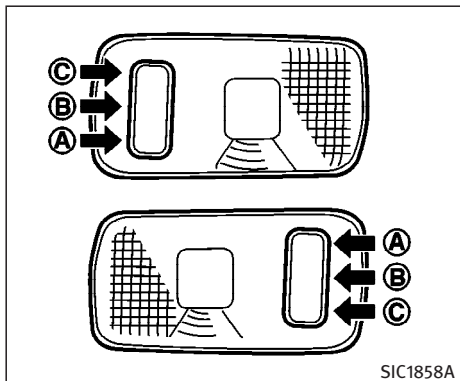

### REAR PERSONAL LIGHT

The rear personal light has a three-position switch.

When the switch is in the door position (B), the light will illuminate when the door is opened.

**When the personal light switch is in the ON position (A), it will automatically turn off 30 minutes after the ignition switch has been turned to the OFF position (C). To turn on the light again, turn the ignition switch to the ON position.**

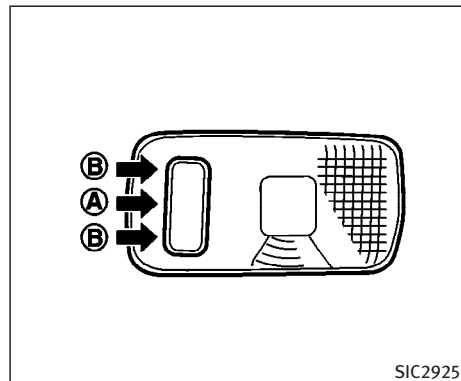

Body side

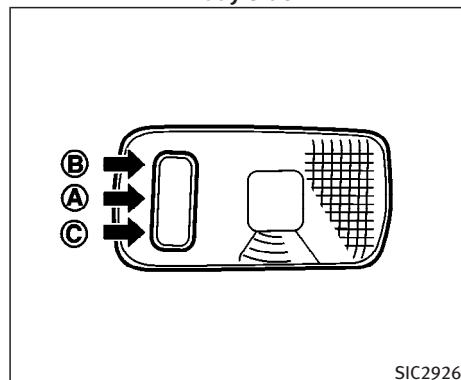

Door side

## LUGGAGE ROOM LIGHT

This luggage room light has a three-position switch.

When the switch is in the door position (A), the light illuminates while the lift gate is opened. When the lift gate is closed, the light will go off.

When the luggage room light switch is in the on position (C), the luggage room light illuminates, regardless of any condition.

When the switch is in the off position (B), the light will turn off.

## VANITY MIRROR LIGHT

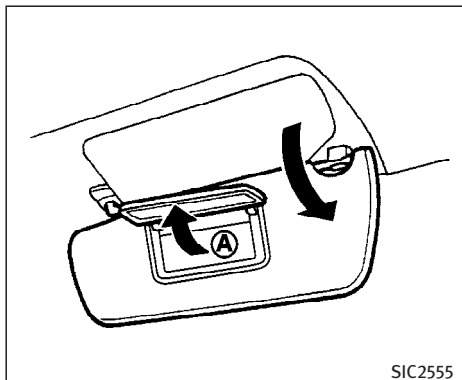

The light on the vanity mirror will turn on when the cover on the vanity mirror (A) is opened.

**When the vanity mirror light stays on, it will automatically turn off 30 minutes after the ignition switch has been turned to the OFF position. To turn on the light again, turn the ignition switch to the ON position.**

## HomeLink® UNIVERSAL TRANSCEIVER (if so equipped)

The HomeLink® Universal Transceiver provides a convenient way to consolidate the functions of up to three individual hand-held transmitters into one built-in device.

The HomeLink® Universal Transceiver power will automatically turn off 30 minutes after the ignition switch has been turned to the OFF position.

HomeLink® Universal Transceiver:

- Will operate most Radio Frequency (RF) devices such as garage doors, gates, home and office lighting, entry door locks and security systems.
- Is powered by your vehicle's battery. No separate batteries are required. If the vehicle's battery is discharged or is disconnected, HomeLink® will retain all programming.

**Once the HomeLink® Universal Transceiver is programmed, retain the original transmitter for future programming procedures (i.e., new vehicle purchases). Upon sale of the vehicle, the programmed HomeLink® Universal Transceiver buttons should be erased for security purposes. For additional information, refer to "Programming HomeLink®" later in this section.**



## WARNING

- Do not use the HomeLink<sup>®</sup> Universal Transceiver with any garage door opener that lacks safety stop and reverse features as required by federal safety standards. (These standards became effective for opener models manufactured after April 1, 1982). A garage door opener which cannot detect an object in the path of a closing garage door and then automatically stop and reverse, does not meet current federal safety standards. Using a garage door opener without these features increases the risk of serious injury or death.
- During the programming procedure, your garage door or security gate will open or close (if the transmitter is within range). Make sure that people and objects are clear of the garage door, gate, etc. that you are programming.

- Your vehicle's engine should be turned off while programming the HomeLink<sup>®</sup> Universal Transceiver.

## PROGRAMMING HomeLink<sup>®</sup>

To program your HomeLink<sup>®</sup> Universal Transceiver to operate a garage door, gate, or entry door opener, home or office lighting, you need to be at the same location as the device. Note: Garage door openers (manufactured after 1996) have “rolling code protection”. To program a garage door opener equipped with “rolling code protection”; you will need to use a ladder to get up to the garage door opener motor to be able to access the “smart or learn” program button.

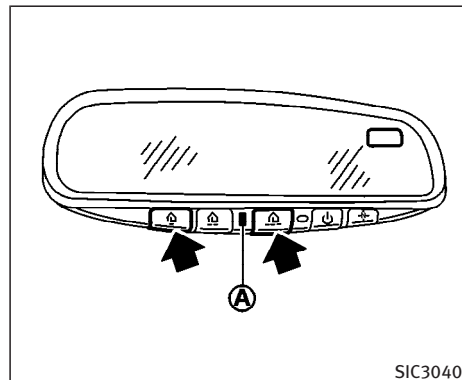

1. To begin, press and hold the 2 outer HomeLink<sup>®</sup> buttons (to clear the memory) until the indicator light (A) blinks (after 20 seconds). Release both buttons.
2. Position the end of the hand-held transmitter 1-3 inches away from the HomeLink<sup>®</sup> surface.



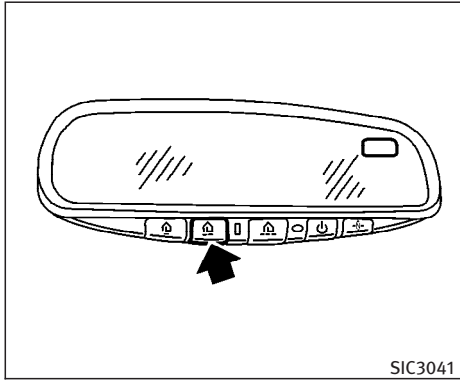

3. Using both hands, simultaneously press and hold both the HomeLink<sup>®</sup> button you want to program and the hand-held transmitter button. DO NOT release the buttons until step 4 has been completed.
4. Hold down both buttons until the indicator light on the HomeLink<sup>®</sup> flashes, changing from a “slow blink” to a “rapid blink”. When the indicator light blinks rapidly, both buttons may be released. The rapidly flashing light indicates successful programming. To activate the garage door or other programmed device, press and hold the

programmed HomeLink<sup>®</sup> button - releasing when the device begins to activate.

5. If the indicator light on the HomeLink<sup>®</sup> blinks rapidly for two seconds and then turns solid, HomeLink<sup>®</sup> has picked up a “rolling code” garage door opener signal. You will need to proceed with the next steps to train the HomeLink<sup>®</sup> to complete the programming which may require a ladder and another person for convenience.
6. Press and release the training button located on the garage door opener’s motor to activate the “training mode”. This button is usually located near the antenna wire that hangs down from the motor. If the wire originates from under a light lens, you will need to remove the lens to access the training button.

**NOTE:**

**Once you have pressed and released the training button on the garage door opener’s motor and the “training light” is lit, you have 30 seconds in which to perform step 7. Use the help of a second person for convenience to assist when performing this step.**

7. Quickly within 30 seconds of pressing and releasing the garage door opener program button, firmly press and release the HomeLink<sup>®</sup> button you have just programmed. Press and release the HomeLink<sup>®</sup> button up to three times to complete the training.
8. Your HomeLink<sup>®</sup> button should now be programmed. (To program the remaining HomeLink<sup>®</sup> buttons for additional door or gate openers, follow steps 2-8 only.)

**NOTE:**

**Do not repeat step one unless you want to “clear” all previously programmed HomeLink<sup>®</sup> buttons).**

If you have any questions or are having difficulty programming your HomeLink<sup>®</sup> buttons, please refer to the HomeLink<sup>®</sup> web site at: [www.homelink.com](http://www.homelink.com) or call 1-800-355-3515.

**PROGRAMMING HomeLink<sup>®</sup> FOR CANADIAN CUSTOMERS**

Prior to 1992, D.O.C. regulations required hand-held transmitters to stop transmitting after 2 seconds. To program your hand-held transmitter to HomeLink<sup>®</sup>, con-

tinue to press and hold the HomeLink<sup>®</sup> button (note steps 2 through 4 under “Programming HomeLink<sup>®</sup>”) while you press and re-press (“cycle”) your hand-held transmitter every 2 seconds until the indicator light flashes rapidly (indicating successful programming).

#### NOTE:

**If programming a garage door opener, etc., it is advised to unplug the device during the “cycling” process to prevent possible damage to the garage door opener components.**

### OPERATING THE HomeLink<sup>®</sup> UNIVERSAL TRANSCIVER

The HomeLink<sup>®</sup> Universal Transceiver (once programmed) may now be used to activate the garage door, etc. To operate, simply press the appropriate programmed HomeLink<sup>®</sup> Universal Transceiver button. The red indicator light will illuminate while the signal is being transmitted.

### PROGRAMMING TROUBLE-DIAGNOSIS

If the HomeLink<sup>®</sup> does not quickly learn the hand-held transmitter information:

- replace the hand-held transmitter batteries with new batteries.

- position the hand-held transmitter with its battery area facing away from the HomeLink<sup>®</sup> surface.
- press and hold both the HomeLink<sup>®</sup> and hand-held transmitter buttons without interruption.
- position the hand-held transmitter 2 to 5 inches (50 to 127 mm) away from the HomeLink<sup>®</sup> surface. Hold the transmitter in that position for up to 15 seconds. If HomeLink<sup>®</sup> is not programmed within that time, try holding the transmitter in another position - keeping the indicator light in view at all times.

If you continue to have programming difficulties, please contact the INFINITI Consumer Affairs Department. The phone numbers are located in the Foreword of this Owner’s Manual.

### CLEARING THE PROGRAMMED INFORMATION

Individual buttons cannot be cleared, however to clear all programming, press and hold the two outside buttons and release when the indicator light begins to flash (approximately 20 seconds).

### REPROGRAMMING A SINGLE HomeLink<sup>®</sup> BUTTON

To reprogram a HomeLink<sup>®</sup> Universal Transceiver button, complete the following.

1. Press and hold the desired HomeLink<sup>®</sup> button. **Do not** release the button until step 4 has been completed.
2. When the indicator light begins to flash slowly (after 20 seconds), position the hand-held transmitter 2 to 5 inches (50 to 127 mm) away from the HomeLink<sup>®</sup> surface.
3. Press and hold the hand-held transmitter button.
4. The HomeLink<sup>®</sup> indicator light will flash, first slowly and then rapidly. When the indicator light begins to flash rapidly, release both buttons.

The HomeLink<sup>®</sup> Universal Transceiver button has now been reprogrammed. The new device can be activated by pushing the HomeLink<sup>®</sup> button that was just programmed. This procedure will not affect any other programmed HomeLink<sup>®</sup> buttons.

## IF YOUR VEHICLE IS STOLEN

If your vehicle is stolen, you should change the codes of any non-rolling code device that has been programmed into HomeLink<sup>®</sup>. Consult the Owner's Manual of each device or call the manufacturer or dealer of those devices for additional information.

**When your vehicle is recovered, you will need to reprogram the HomeLink<sup>®</sup> Universal Transceiver with your new transmitter information.**

### **FCC Notice:**

**This device complies with FCC rules part 15. Operation is subject to the following two conditions: (1) This device may not cause harmful interference and (2) This device must accept any interference that may be received, including interference that may cause undesired operation.**

**The transmitter has been tested and complies with FCC and DOC/MDC rules. Changes or modifications not expressly approved by the party responsible for compliance could void the user's authority to operate the device.**

**DOC: ISTC 1763K1313**

**FCC I.D.: CB2V67690**

**MEMO**

# 3 Pre-driving checks and adjustments

Keys (except Intelligent Key) .....	3-2	Operation with intelligent remote keyless entry system .....	3-20
INFINITI Vehicle Immobilizer System keys...	3-2	Operation with the mechanical key and valet key .....	3-23
Doors .....	3-3	Hood .....	3-24
Locking with key (Driver's door only) .....	3-3	Lift gate .....	3-24
Opening and closing windows with the key...	3-4	Auto closure .....	3-25
Locking with inside lock knob .....	3-4	Fuel-filler door .....	3-26
Locking with power door lock switch .....	3-4	Open the fuel-filler door.....	3-26
Child safety rear door lock .....	3-5	Fuel-filler cap .....	3-27
Remote keyless entry system (models without Intelligent Key system) .....	3-5	Tilting telescopic steering column .....	3-28
How to use remote keyless entry system .....	3-6	Automatic operation .....	3-29
Intelligent Key system (if so equipped) .....	3-9	Sun visors .....	3-29
Door locks/unlocks precaution .....	3-11	Mirrors .....	3-30
Intelligent Key operation .....	3-12	Automatic anti-glare inside mirror .....	3-30
Opening and closing windows.....	3-13	Outside mirrors .....	3-31
Operating the engine .....	3-14	Automatic drive positioner .....	3-32
Intelligent Key operating range .....	3-16	Memory storage function .....	3-32
Warning signals.....	3-17	Entry/exit function .....	3-33
Trouble-shooting guide.....	3-19		

## KEYS (except Intelligent Key)

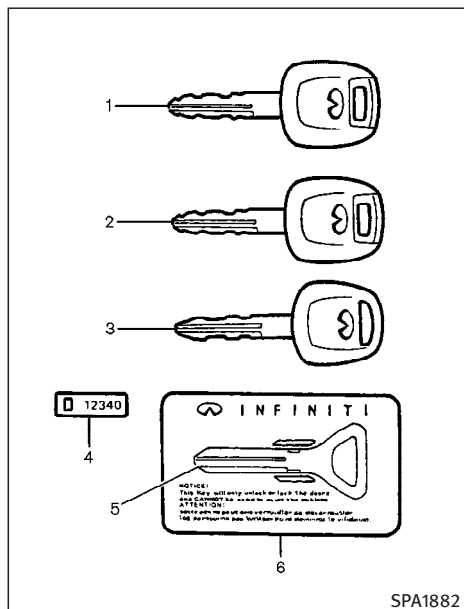

1. Master key 1 (With built-in transponder chip; INFINITI mark-silver)
2. Master key 2 (With built-in transponder chip; INFINITI mark-silver)

### 3-2 Pre-driving checks and adjustments

3. Valet key (With built-in transponder chip; INFINITI mark-black)
4. Key number plate
5. Wallet key
6. key case (Card type)

A key number plate is supplied with your keys. Record the key number and keep it in a safe place (such as your wallet), not in the vehicle. If you lose your keys, see an INFINITI dealer for duplicates by using the key number.

A key number is necessary when you have lost all keys and do not have one to duplicate from. If you still have a key, an INFINITI dealer can duplicate it.

### INFINITI VEHICLE IMMOBILIZER SYSTEM KEYS

You can only drive your vehicle using the master or valet keys which are registered to the INFINITI Vehicle Immobilizer System components in your vehicle. These keys have a transponder chip in the key head.

The master key can be used for all the locks.

The valet key cannot be used for glove box lock.

To protect belongings when you leave a key with someone, give them the valet key only.

### Never leave these keys in the vehicle.

Additional or replacement keys:

If you still have a key, the key number is not necessary when you need extra INFINITI Vehicle Immobilizer System keys. An INFINITI dealer can duplicate it. As many as 5 INFINITI Vehicle Immobilizer System keys can be used with one vehicle. You should bring all registered keys that you have to an INFINITI dealer for registration. This is because the registration process will erase the memory of all key codes previously registered into the INFINITI Vehicle Immobilizer System. After the registration process, these components will only recognize keys coded into the INFINITI Vehicle Immobilizer System during registration. Any key that is not given to your dealer at the time of registration will no longer be able to start your vehicle.

## DOORS

Do not allow the immobilizer system key, which contains an electrical transponder, to come into contact with salt water. This could affect system function.



### WARNING

- Always have the doors locked while driving. Along with the use of seat belts, this provides greater safety in the event of an accident by helping to prevent persons from being thrown from the vehicle. This also helps keep children and others from unintentionally opening the doors, and will help keep out intruders.
- Before opening any door, always look for and avoid oncoming traffic.
- Do not leave children unattended inside the vehicle. They could unknowingly activate switches or controls. Unattended children could become involved in serious accidents.

If your vehicle is equipped with a Intelligent Key system, refer to “Intelligent Key system” later in this section.

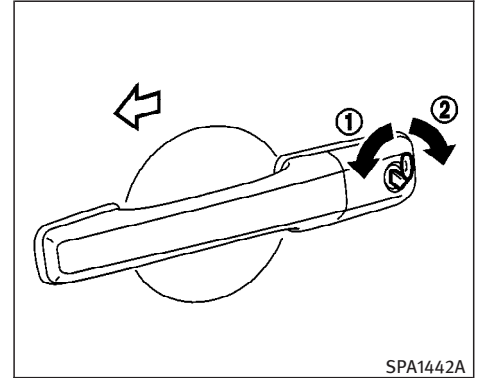

### LOCKING WITH KEY (Driver's door only)

The power door lock system allows you to lock or unlock all doors simultaneously.

- Turning the driver's door key lock with the metal key (master key, mechanical key, valet key and wallet key) toward the front of the vehicle ① will lock all doors.
- Turning the driver's door key one time to the rear of the vehicle ② will unlock the driver's door. From that position, returning the key to neutral (where the

key can only be removed and inserted) and turning it to the rear again within 5 seconds will unlock all doors. (including the lift gate) and fuel-filler door.

## OPENING AND CLOSING WINDOWS WITH THE KEY

The driver's door key operation allows you to open and close the front windows simultaneously.

To open the windows, turn the driver's door key cylinder to the rear of the vehicle for **longer than 1 second**. The door is unlocked and the window keeps opening while turning the key.

This function can also be performed by pushing and holding the door UNLOCK button of the Intelligent Key. Refer to "Intelligent remote keyless entry system" later in this section.

To close the windows, turn the driver's door key cylinder to the front of the vehicle for **longer than 1 second**. The door is locked and the window keeps closing while turning the key.

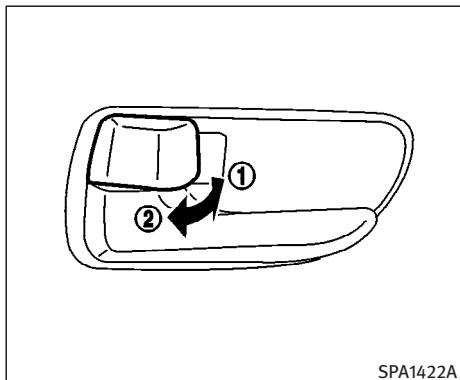

SPA1422A

## LOCKING WITH INSIDE LOCK KNOB

To individually lock the doors, move the inside lock knob to the LOCK position ①, then close the door. To unlock, pull up the inside lock knob to the UNLOCK position ②.

**When locking the door without a key, be sure not to leave the key inside the vehicle.**

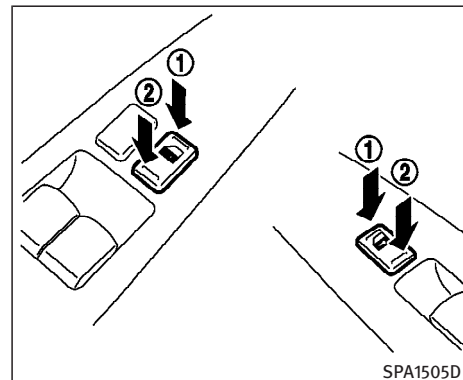

SPA1505D

## LOCKING WITH POWER DOOR LOCK SWITCH

Operating the power door lock switch located on the driver's or front passenger's armrest will lock or unlock all doors including the lift gate.

To lock the doors, push the power door lock switch to the lock position ① with the driver's or front passenger's door open, then close the door.

**When locking the door this way, be certain not to leave the key inside the vehicle.**



To unlock, push the power door lock switch to the unlock position ②.

### Lockout protection

When the power door lock switch (driver or front passenger) is moved to the lock position with the key in the ignition and any door open, all doors will lock and unlock automatically. This helps to prevent the keys from being accidentally locked inside the vehicle.

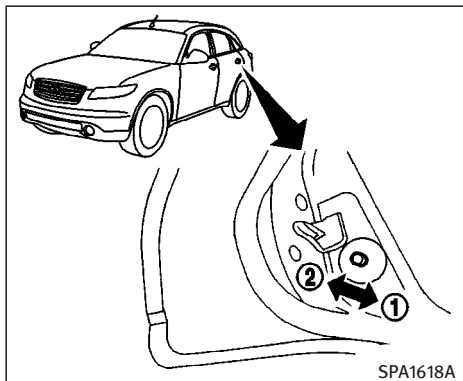

### CHILD SAFETY REAR DOOR LOCK

Child safety locking helps prevent doors from being opened accidentally, especially when small children are in the vehicle.

**When the lever is in the LOCK position ①, the rear door can be opened only from the outside.**

To disengage, move the lever to the FREE position ②.

### REMOTE KEYLESS ENTRY SYSTEM (models without Intelligent Key system)

It is possible to lock/unlock all doors (including the lift gate) and fuel-filler door and activate the panic alarm by using the keyfob from outside the vehicle.

**Before locking the doors, make sure the key is not left in the vehicle.**

The keyfob can operate at a distance of approximately 33 ft (10 m) from the vehicle. (The effective distance depends upon the conditions around the vehicle.)

As many as 4 keyfobs can be used with one vehicle. For information concerning the purchase and use of additional keyfob, contact an INFINITI dealer.

The keyfob will not function when:

- the battery is completely discharged,
- the distance between the vehicle and the keyfob is over 33 ft (10 m).

**The panic alarm will not activate when the key is in the ignition switch.**



### CAUTION

The following conditions or occurrences will damage the keyfob.

- Do not allow the keyfob to become wet.
- Do not drop the keyfob.
- Do not strike the keyfob sharply against another object.
- Do not place the keyfob for an extended period in an area where temperatures exceed 140°F (60°C).

If a keyfob is lost or stolen, INFINITI recommends erasing the ID code of that keyfob. This will prevent the keyfob from unauthorized use to unlock the vehicle. For information regarding the erasing procedure, please contact an INFINITI dealer.

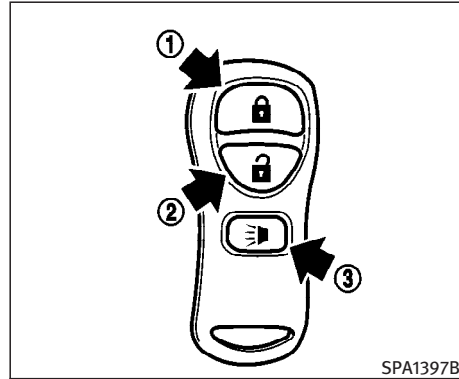

## HOW TO USE REMOTE KEYLESS ENTRY SYSTEM

### Setting hazard indicator and horn mode

This vehicle is set in hazard indicator and horn mode when you first receive the vehicle.

In hazard indicator and horn mode, when the LOCK button ① is pushed, the hazard indicator flashes twice and the horn chirps once. When the UNLOCK button ② is pushed, the hazard indicator flashes once.

OPERATION GUIDE			
MODE (Push "LOCK" and "UNLOCK" buttons for more than 2 seconds to switch)	Switching indicator	LOCK	UNLOCK
Hazard indicator and horn → <b>HAZARD INDICATOR ONLY</b>	HAZARD – 3 times	HAZARD – twice	No operation
Hazard indicator only → <b>HAZARD INDICATOR AND HORN</b>	HAZARD – once HORN – once	HAZARD – twice HORN – once	HAZARD – once

SPA1260

If hazard indicator and horn mode is not necessary, you can switch to hazard indicator only mode by following the switching procedure.

In hazard indicator only mode, when the LOCK button ① is pushed, the hazard indicator flashes twice. When the UNLOCK button ② is pushed, neither the hazard indicator nor the horn operates.

(Switching procedure)

Push the LOCK ① and UNLOCK ② buttons on the keyfob simultaneously for more

than 2 seconds to switch from one mode to the other.

When pushing the buttons to set hazard indicator only mode, the hazard indicator flashes 3 times.

When pushing the buttons to set hazard indicator and horn mode, the hazard indicator flashes once and the horn chirps once.

The hazard indicator and horn mode also can be changed with vehicle electronic systems on the monitor. See "4. Display

screen, heater, air conditioner and audio systems".

## Locking doors and fuel-filler door

1. Remove the ignition key.\*1,\*2
2. Close all the doors.\*3
3. Push the LOCK button ① on the keyfob.
4. All the doors and fuel-filler door will lock.

**All of the doors will lock when the LOCK button ① on the keyfob is pushed even though a door remains open and/or the ignition key is in the ON position.**

5. The hazard indicator flashes twice and the horn chirps once.
  - When the LOCK button ① is pushed with all doors locked, the hazard indicator flashes twice and the horn chirps once as a reminder that the doors are already locked.

\*1: Doors lock with the keyfob while a key is in the ignition switch. However, the panic alarm will not activate when the key is in the ignition switch.

\*2: Doors lock with the keyfob while the ignition switch is in the ON position. However, the hazard indicator and horn will not function.

\*3: Doors lock with the keyfob while any door is open. However, the hazard indicator and horn will not function.

### Unlocking doors and fuel-filler door

1. Push the UNLOCK button ② on the keyfob once.
  - The driver's door and fuel-filler door unlock
  - The hazard indicator flashes once if all doors are completely closed with the ignition key in any position except the ON position.
  - The interior light turns on and the light timer activates for 30 seconds when the switch is in the DOOR position with the ignition key in any position except the ON position.
2. Push the UNLOCK button ② on the keyfob again within 5 seconds.
  - All doors unlock
  - The hazard indicator flashes once if all doors are completely closed.

### 3-8 Pre-driving checks and adjustments

All doors will be locked automatically unless one of the following operations is performed within 1 minute of pushing the UNLOCK button ②.

- any door is opened
- the ignition switch is turned to the ON position

The interior light can be turned off without waiting for 30 seconds by turning the ignition switch to the ON position or by locking the doors with the keyfob.

### Opening the windows

Push the UNLOCK button ② on the keyfob.

The driver's door will unlock.

Continue to push the UNLOCK button ② for 3 seconds. The door windows will be lowered.

Continue to push the UNLOCK button ② until windows are fully open.

To stop lowering the windows, release the UNLOCK button ②.

To start lowering the windows, push the UNLOCK button ② again for more than 3 seconds.

The rear door windows will operate 0.5 seconds after the front windows' operation. (if so equipped)

### Using the panic alarm

If you are near your vehicle and feel threatened, you may activate the alarm to call attention as follows:

1. Push the PANIC button ③ on the keyfob for **longer than 0.5 seconds** with the key removed from the ignition switch.
2. The theft warning alarm and headlights will stay on for 30 seconds.
3. The panic alarm stops when:
  - It has run for 30 seconds, or
  - The LOCK ① or the UNLOCK ② button is pushed, or
  - The PANIC button ③ is pushed on the keyfob for longer than 0.5 seconds.

## INTELLIGENT KEY SYSTEM (if so equipped)

The Intelligent Key uses coded radio signals to communicate with the vehicle. When the Intelligent Key is near the vehicle, such as in your pocket or purse, it allows the vehicle to be locked, unlocked, or started without inserting the ignition key. It is also possible to use the remote control entry function.



### CAUTION

- Be sure to carry the Intelligent Key with you.
- Do not leave the vehicle with the Intelligent Key inside.
- The Intelligent Key may not function correctly depending on the environment or operating conditions. It could also malfunction if you do not use it correctly.
- The Intelligent Key transmits faint radio waves.

In the following situations, the Intelligent Key and remote control entry functions may not operate correctly, and you may have to use the metal key (mechanical key, valet key or wallet key):

- when there are strong signals coming from a television tower, power station or broadcasting station.
- when you have wireless equipment or a cellular phone with you.
- when the Intelligent Key is in contact with or covered by a metallic material.
- when radio wave-type remote control entry is used nearby.
- when the Intelligent Key is placed near an electric appliance such as a personal computer.
- The Intelligent Key continually consumes battery power as the key receives a signal to communicate with the vehicle. Battery life is about 2 years, although it varies depending on the operating conditions. When the battery of the Intelligent Key is low, the green blinking key warning light goes out about 30 seconds after the ignition switch is turned to ON. If the battery runs down, replace it with a new one.
- If the Intelligent Key receives strong signal over an extended period of time,

the battery could quickly run down. Do not place the Intelligent Key near an electric appliance such as a television set or personal computer.

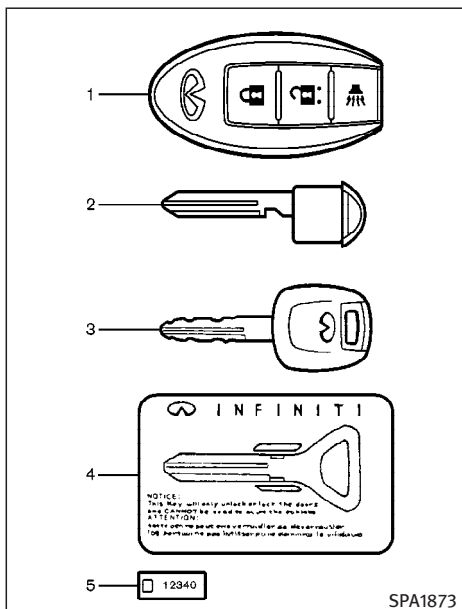

1. Intelligent Key 2 sets
2. Mechanical key (metal key)\* 2 sets
3. Valet key (metal key)\* 1 set
4. Wallet key and key case (card type) (metal key) 1 set
5. Key number plate 1 set

### 3-10 Pre-driving checks and adjustments

\*: Refer to “INFINITI Vehicle Immobilizer System keys” earlier in this section.

#### WARNING

- The Intelligent Key transmits radio waves that can adversely affect medical electric equipment.
- If you have a pacemaker, you should contact the medical equipment manufacturer to ask if it will be affected by the Intelligent Key signal.

The valet key cannot be used for the glove box lock.

To protect belongings when you leave a key with someone, give them the valet key only.

Record the key number on the key number plate/metal tag and keep it in a safe place (such as your wallet), NOT IN THE VEHICLE. A key number plate is supplied with your key. Keep the plate in a safe place. INFINITI does not record key numbers so it is very important to keep track of your key number plate.

As many as 4 Intelligent Keys can be used with one vehicle. For information concerning the purchase and use of additional Intelligent Keys, contact an INFINITI dealer.

It is possible that the Intelligent Key functions can become cancelled. Contact an INFINITI dealer.

#### CAUTION

Be sure to carry the Intelligent Key with you when driving. The Intelligent Key is a precision device with a built-in transmitter. To avoid damaging it, please note the following.

- Wetting may damage the Intelligent Key. If the Intelligent Key gets wet, immediately wipe until it is completely dry.
- Do not bend, drop or strike it against another object.
- Do not place the Intelligent Key for an extended period in a place where temperatures exceed 140°F (60°C).
- Do not change or modify the Intelligent Key.

- Do not use a magnet key holder.
- Do not place the Intelligent Key near an electric appliance such as a television set or personal computer.
- Do not place the Intelligent Key in a storage area (for example, a door pocket or glove box). It could be damaged or activated unexpectedly.
- Do not allow the Intelligent Key to come into contact with water or salt water, and be careful not to let the key be washed in a washing machine. This could affect the system function.
- If an Intelligent Key is lost or stolen, INFINITI recommends erasing the ID code of that Intelligent Key. This will prevent the Intelligent Key from unauthorized use to unlock the vehicle. For information regarding the erasing procedure, please contact an INFINITI dealer.

## DOOR LOCKS/UNLOCKS PRECAUTION

- After locking with the door handle request switch, make sure the doors are securely locked.
- To prevent the Intelligent Key from being left inside the vehicle, make sure you carry the key with you and then lock the doors.
- You can lock or unlock the doors using only the door handle, which detects the Intelligent Key.
- It is not possible to lock the doors with the lock knob when the driver's door is open, the ignition switch is pushed in or the metal key is in the ignition switch.
- When you try to unlock the door while pulling the door handle, the door may not unlock. In this case, release the door handle and the door will unlock. Pull the door handle again and the door will open.
- The outside beep, which indicates the lock and unlock functions, can be canceled with the LOCK/UNLOCK button on the Intelligent Key and the vehicle elec-

tronic system on the monitor. See “4. Display screen, heater, air conditioner and audio systems”.

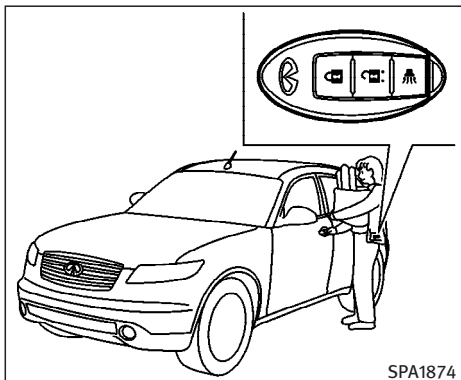

SPA1874

## INTELLIGENT KEY OPERATION

You can lock or unlock the doors without taking the key out from your pocket or purse.

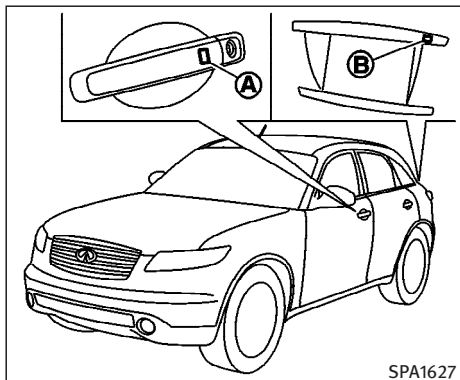

SPA1627

When you carry the Intelligent Key with you, you can lock or unlock all doors by pushing the door handle request switch (A) or lift gate handle request switch (B) within the range of operation.

### Locking doors

1. Turn the ignition switch to the LOCK position and remove the ignition key if any metal key is in the ignition switch.\*1, \*2
2. Close all the doors.\*3

3. Push any front door or the lift gate handle request switch while carrying the Intelligent Key with you.\*4
4. All the doors, lift gate and fuel-filler door will lock.
5. The hazard indicator flashes twice and door buzzer sounds twice.

**The hazard indicator and horn mode also can be changed with vehicle electronic systems on the monitor. See “4. Display screen, heater, air conditioner and audio systems”.**

- \*1: Doors lock with the Intelligent Key while a mechanical key or valet key is in the ignition switch.
- \*2: Doors lock with the Intelligent Key while the ignition switch is not in the LOCK position.
- \*3: Doors do not lock by pushing the door handle request switch or the LOCK button on the Intelligent Key while any door is open. A beep sounds to warn you. However, doors lock with the metal key even if any door is open.
- \*4: Doors do not lock with door handle request switch with the Intelligent Key inside the vehicle and a beep sounds to warn you.



However, when an Intelligent Key is inside the vehicle, doors can be locked with another Intelligent Key.

## Unlocking doors

1. Push the door handle request switch once.

Driver's side:

- The driver door and fuel-filler door unlock.

Front passenger side or lift gate:

- Only corresponding door unlocks.
2. The hazard indicator flashes once and door buzzer sounds once if all doors are completely closed with the ignition key in any position except the ON position.
  3. Push the door handle request switch again within 5 seconds.
    - All doors and the fuel-filler door unlock.
    - The hazard indicator flashes once and door buzzer sounds once if all doors are completely closed.

All doors will be locked automatically after pressing the unlocking button unless one of the following operations is performed within 1 minute.

- any door is opened
- the ignition switch is pushed
- the mechanical key or the valet key is inserted into the ignition switch

The interior light, ceiling light (if so equipped) and step light can be turned off without waiting for 30 seconds by turning the ignition switch to the ON position or by locking the doors.

## OPENING AND CLOSING WINDOWS

- To open the windows, push the UNLOCK button on the Intelligent Key for **about 3 seconds** or turn the driver's door key lock with the metal key to the rear of the vehicle for **about 2 seconds** after the door is unlocked.

To stop opening, release the UNLOCK button or turn the key to the neutral position.

- To close the windows, turn the driver's door key lock to the front of the vehicle for **about 2 seconds** after the door is locked.

To stop closing, turn the key to the neutral position.

The door windows will open or close while turning the metal key. See "Doors" earlier in this section.

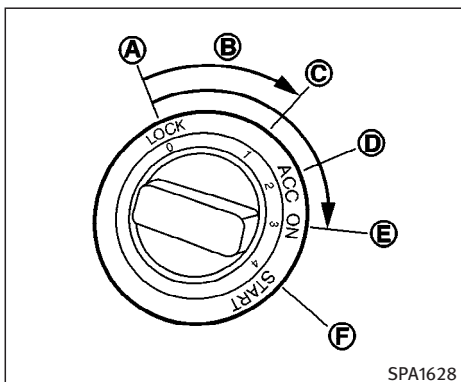

## OPERATING THE ENGINE

### Ignition switch positions

Push in the ignition switch in the (B) range when you turn it.

#### **LOCK (Normal parking position) (A):**

The ignition switch can only be locked in the (A) position.

The ignition switch will be unlocked when it is pushed in, and turned to the ACC position (D) while carrying the Intelligent Key.

#### **ACC (Accessories) (D):**

This position activates electrical accessories such as the radio, when the engine is not running.

#### **ON (Normal operating position) (E):**

This position turns on the ignition system and electrical accessories.

#### **START (F):**

This position starts the engine. As soon as the engine has started, release the knob immediately. It will automatically return to the ON position.

For important safety information, see “Ignition switch” in the “5. Starting and driving” section.

The ignition switch cannot be turned back to the LOCK position unless the shift lever is in P position. (It can be turned to only (C).)



## CAUTION

Do not leave the vehicle with the ignition switch in ACC or ON positions when the engine is not running for an extended period. This can discharge the battery.

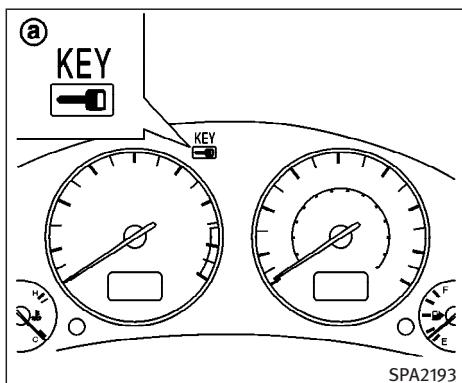

## Starting the engine

When driving the vehicle, be sure to carry the Intelligent Key with you.

1. Securely depress the brake pedal.
2. Slowly push the ignition switch in. When the Intelligent Key warning light **a** in the instrument panel comes on in green, the ignition switch can be turned.
3. Turn the ignition switch to START and the engine will be started.

4. When the engine starts, release the ignition switch.



## WARNING

**Do not start the engine from outside the vehicle through the window. Doing so could lead to an accident and injury. Be sure to sit in the driver's seat to use the key.**

For important safety information, see “Starting the engine” in the “5. Starting and driving” section.

- When the ignition switch is pushed under the following conditions, the key warning light in the instrument panel comes on in red. It is not possible to turn the ignition switch when:
  - you do not have the Intelligent Key with you
  - the Intelligent Key battery has run down
  - you have a Intelligent Key for another vehicle with you
- Slowly turn the ignition switch after the key warning light comes on in green. If

it is turned quickly, it may stick and be difficult to turn.

- The engine may not start if the Intelligent Key is placed:
  - inside the glove box or the door pocket
  - on the instrument panel
  - in the corner of interior compartment.
- If it is difficult to turn the ignition switch, perform the following:
  - Push the ignition switch again and slowly turn it.
  - Turn the ignition switch while gently turning the steering wheel to the left or right.

## Stopping the engine

1. Shift the selector lever to the P position.
2. Turn the ignition switch to ACC.



## WARNING

When you leave the vehicle, be sure to observe the following:

- Shift the selector lever to P. (In other positions, the ignition switch will not return to LOCK.)
- Securely return the ignition switch to LOCK.
- Set the parking brake. Failure to do so could result in unexpected vehicle movement and could lead to severe injury.

## INTELLIGENT KEY OPERATING RANGE

The Intelligent Key functions can be used only when you carry the key with you and operate as specified in the operating range inside or outside the vehicle.

When the Intelligent Key battery runs down or where there are strong radio waves or noise, the operating range may be narrower or the key may be inoperative.

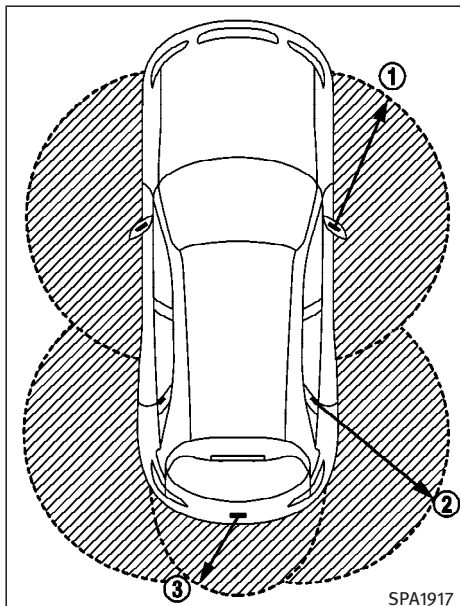

## Operating range of the door lock/unlock function

The outside sensors are in the outside mirrors, rear door corner pieces and the lift gate.

The operating range of the door lock/unlock function is shown in the illustration.

- ① 59.1 in (1.5 m) from the outside mirrors
- ② 59.1 in (1.5 m) from the rear door corner pieces
- ③ 31.5 in (80 cm) from the lift gate handle

- If you are too close to the door glass, the Intelligent Key may not operate.
- If the Intelligent Key is in the operating range, it is possible for anyone who does not carry the Intelligent Key to lock/unlock the doors by pushing the door handle request switch.

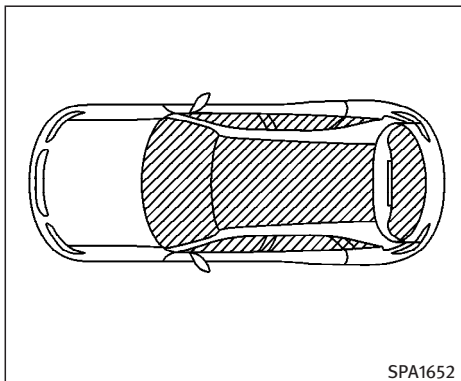

### Operating range for engine start function

The operating range for starting the engine is inside the vehicle.

- If the Intelligent Key is on the instrument panel, inside the glove box or door pocket, or the corner of interior compartment, it may not be possible to start the engine.
- If the Intelligent Key is near the door or door glass outside the vehicle, it may be possible to start the engine.

### WARNING SIGNALS

To help prevent the vehicle from moving unexpectedly by erroneous operation of the Intelligent Key or to help prevent the vehicle from being stolen, chime or beep sounds inside and outside the vehicle and a warning light comes on in the instrument panel.

When a chime or beep sounds or the warning light comes on, be sure to check the vehicle and Intelligent Key.

#### Alarm and warning when locking the doors

When the front door warning chime or beep sounds, check for the following:

- The ignition switch is turned to LOCK.
- The Intelligent Key is not left inside the vehicle.
- Doors are closed securely.
- The selector lever is in the P position.

The door beep sounds for about 2 seconds.

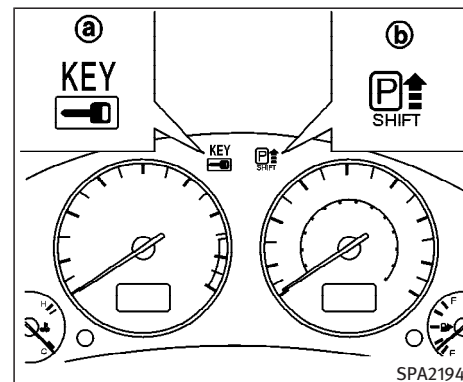

#### Alarm and warning when the engine stops

When the P position selecting warning light (b) in the instrument panel blinks in red:

- Make sure the selector lever is in the P position.

When the chime sounds intermittently:

- Make sure the selector lever is in the P position and the ignition switch is turned to LOCK.

If the chime sounds continuously when the driver's door is opened, check the following:

- The selector lever is in the P position and the ignition switch is turned to LOCK.
- The mechanical key or the valet key is not inserted into the ignition switch.
- The inside warning chime may stop when one of the following is performed.
  - Returning the ignition switch to LOCK.
  - Removing the mechanical key or the valet key.
  - Closing the doors.

### Alarm and warning when the engine starts

When the key warning light  is blinking in red and the outside buzzer sounds, make sure the Intelligent Key is inside the vehicle.

The buzzer sounds for about 3 seconds.

### Warning for low battery power

- This warning is to let you know that the battery of the Intelligent Key will run down soon. Replace it with a new one.
  - The green blinking key warning light  goes out about 30 seconds after the ignition switch is turned to ON.
- We recommend replacing the battery at an INFINITI dealer.

### Preventing the Intelligent Key from being left in the vehicle

If you lock all doors using the power door lock switch with the Intelligent Key in the vehicle, all of the doors unlock immediately and the beep sounds to warn you when the door is closed.

## TROUBLE-SHOOTING GUIDE

Symptom		Possible Cause	Remedy
When pushing the door handle request switch	The front door beep sounds for approximately 2 seconds	The doors cannot be locked.	Take out the Intelligent Key from the vehicle and push the door handle request switch.
			Turn the ignition switch to LOCK and push the door handle request switch carrying the Intelligent Key with you.
			Close all doors securely and push the door handle request switch carrying the Intelligent Key with you.
When closing the doors	The front door beep sounds for approximately 10 seconds	The ignition switch is not turned to LOCK position.	Turn the ignition switch to LOCK.
	The key warning light in the instrument panel blinks in red and the front door warning beep sounds for approximately 3 seconds.	The Intelligent Key is not in the vehicle.	Be sure to carry the Intelligent Key with you.
	The front door beep sounds for approximately 3 seconds and all doors unlock.	The Intelligent Key is left in the vehicle.	Take out the Intelligent Key from the vehicle and close the door.
When opening the driver's door	A warning chime sounds continuously	The ignition switch is not in LOCK position, or the mechanical key or valet key is inserted into the ignition switch.	Turn the ignition switch to LOCK.
			Remove the mechanical key or valet key from the ignition switch.
When stopping the engine	The P position warning light in the instrument panel blinks in red.	The selector lever is not in the P position.	Make sure that the selector lever is in the P position.
When turning the ignition switch	The warning chime sounds	The ignition switch is not turned to LOCK.	Turn the ignition switch to LOCK.
When starting the engine	The key warning light in the instrument panel blinks in green.	The battery charge is low.	Replace the battery to new one. See "Keyfob battery replacement" in the "8. Maintenance and do-it-yourself" section.

## Trouble-shooting examples

### When it is difficult to turn the ignition switch

- Push the ignition switch again and turn it slowly.
- While gently turning the steering wheel to the left or right, turn the ignition switch.

## OPERATION WITH INTELLIGENT REMOTE KEYLESS ENTRY SYSTEM

It is possible to lock/unlock all doors, fuel-filler door, activate the panic alarm and open the windows by pushing the buttons on the Intelligent Key from outside the vehicle.

**Before locking the doors, make sure the key is not left in the vehicle.**

The LOCK/UNLOCK button on the Intelligent Key can operate at a distance of approximately 33 ft (10 m) from the vehicle. (The effective distance depends upon the conditions around the vehicle.)

As many as 4 Intelligent Keys can be used with one vehicle. For information concerning the purchase and use of additional Intelligent Key, contact an INFINITI dealer.

### 3-20 Pre-driving checks and adjustments

The lock and unlock buttons on the Intelligent Key will not operate when:

- the Intelligent Key is too far away from the vehicle
- the Intelligent Key battery runs down

After locking with the remote control entry function, pull the door handle to make sure the doors are securely locked.

The operating range varies depending on the environment. To securely operate the lock and unlock buttons, approach the vehicle to about 4.9 ft (1.5 m) from the door.

**The panic alarm will not activate when the mechanical key or the valet key is in the ignition switch.**

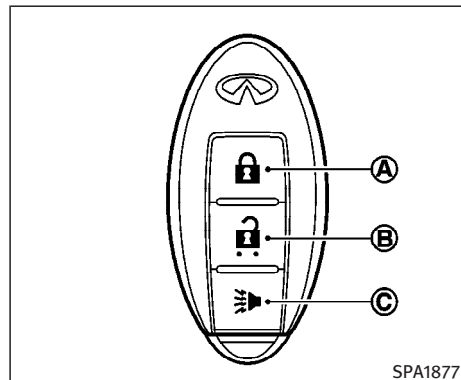

## How to use remote keyless entry system

### Setting hazard indicator and horn mode:

This vehicle is set in hazard indicator and horn mode when you first receive the vehicle.

**The hazard indicator and horn mode also can be changed with vehicle electronic systems on the monitor. See “4. Display screen, heater, air conditioner and audio systems”.**

In hazard indicator and horn mode, when the LOCK button (A) is pushed, the hazard



## OPERATION GUIDE

MODE (Push "LOCK" and "UNLOCK" buttons for more than 2 seconds to switch)	Switching indicator	LOCK	UNLOCK
Hazard indicator and horn → <b>HAZARD INDICATOR ONLY</b>	HAZARD – 3 times	HAZARD – twice	No operation
Hazard indicator only → <b>HAZARD INDICATOR AND HORN</b>	HAZARD – once HORN – once	HAZARD – twice HORN – once	HAZARD – once

SPA1260

indicator flashes twice and the horn chirps once. When the UNLOCK button (B) is pushed, the hazard indicator flashes once.

If hazard indicator and horn mode is not necessary, you can switch to hazard indicator only mode by following the switching procedure.

In hazard indicator only mode, when the LOCK button (A) is pushed, the hazard indicator flashes twice. When the UNLOCK button (B) is pushed, neither the hazard indicator nor the horn operates.

(Switching procedure)

Push the LOCK (A) and UNLOCK (B) buttons on the Intelligent key simultaneously for more than 2 seconds to switch from one mode to the other.

When pushing the buttons to set hazard indicator only mode, the hazard indicator flashes 3 times.

When pushing the buttons to set hazard indicator and horn mode, the hazard indicator flashes once and the horn chirps once.

## Locking doors and fuel-filler door:

1. Remove the mechanical key or the valet key if any key is in the ignition switch.\*1
2. Close all the doors.\*2
3. Push the LOCK button (A) on the Intelligent Key.
4. All the doors (including lift gate) and fuel-filler door will lock.

**All of the doors will lock when the LOCK button (A) on the Intelligent Key is pushed even though the ignition switch is in the ON position.**

5. The hazard indicator flashes twice and the horn chirps once.
  - When the LOCK button (A) is pushed with all doors locked, the hazard indicator flashes twice and the horn chirps once as a reminder that the doors are already locked.

\*1: Doors lock with the Intelligent Key while the mechanical key or the valet key is in the ignition switch or the ignition switch is pushed in.

\*2: Doors do not lock with the Intelligent Key while any door is open.

### Unlocking doors and fuel-filler door:

1. Push the UNLOCK button (B) on the Intelligent Key once.
  - The driver's door and fuel-filler door unlock
  - The hazard indicator flashes once if all doors are completely closed with the ignition switch in any position except the ON position.
  - The interior light turns on and the light timer activates for 30 seconds when the switch is in the DOOR position with the ignition switch in any position except the ON position.
2. Push the UNLOCK button (B) on the Intelligent Key again within 5 seconds.
  - All doors unlock.
  - Lift gate unlocks.
  - The hazard indicator flashes once if all doors are completely closed.

All doors will be locked automatically unless one of the following operations is performed within 1 minute of pressing the UNLOCK button (B).

- any door is open

### 3-22 Pre-driving checks and adjustments

- the ignition switch is pushed
- the mechanical key or the valet key is inserted into the ignition switch

The interior light can be turned off without waiting for 30 seconds by turning the ignition switch to the ON position or by locking the doors with the Intelligent Key.

### Opening the windows:

See "Opening and closing windows" on the previous page.

### Using the panic alarm:

If you are near your vehicle and feel threatened, you may activate the alarm to call attention as follows:

1. Push the PANIC button (C) on the Intelligent Key for **longer than 0.5 seconds** with the metal key removed from the ignition key cylinder or the ignition switch pushed in.
2. The theft warning alarm and headlights will stay on for 25 seconds.
3. The panic alarm stops when:
  - It has run for 25 seconds, or
  - The LOCK (A) or the UNLOCK (B) button is pressed, or

- The PANIC button (C) is pushed on the Intelligent Key for longer than 0.5 seconds.

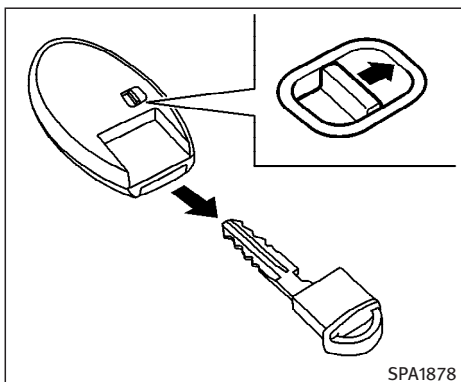

## OPERATION WITH THE MECHANICAL KEY AND VALET KEY

If the Intelligent Key cannot be used because its battery is discharged, use the metal key to lock or unlock the doors and use the mechanical key or the valet key, which is registered to the INFINITI Vehicle Immobilizer System components, to start the engine.

### Removing the mechanical key

- Release the lock knob at the back of the Intelligent Key and remove the mechanical key.

- To install the mechanical key to the Intelligent Key, securely lock the lock knob and then check that the mechanical key will not move.



Be sure to carry the Intelligent Key with the mechanical key installed in it.

### Locking/unlocking the doors with the metal key (mechanical key, valet key and wallet key)

The doors can be locked/unlocked by inserting the metal key into the key cylinder in the driver's door in the same way as the ordinary key.

### Starting the engine with the mechanical key

1. Securely depress the brake pedal.
2. Insert the mechanical key or the valet key into the ignition switch.

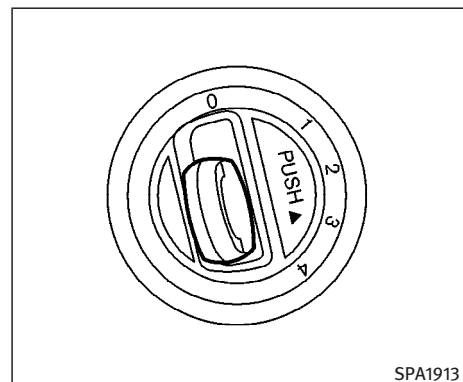

3. Turn the ignition switch to **START** and start the engine.
4. After starting the engine, release the knob.

When the engine is off, the steering wheel lock cannot be unlocked.

For important safety information, see the "5. Starting and driving" section.

### Windows open/close with the mechanical key

See "Opening and closing windows" on the previous page.

## HOOD

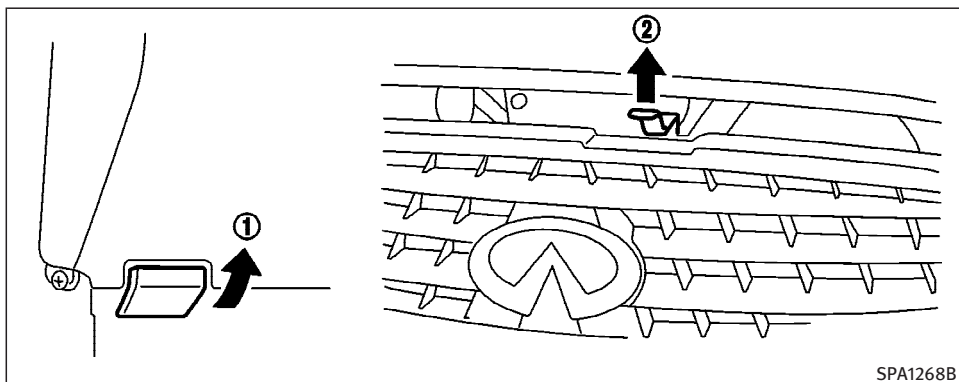

1. Pull the hood lock release handle (1) located below the instrument panel; the hood will then spring up slightly.
2. Pull the lever (2) at the front of the hood with your fingertips and raise the hood.
3. When closing the hood, lower it slowly and make sure it locks into place.



### WARNING

- Make sure the hood is completely closed and latched before driving. Failure to do so could cause the hood to fly open and result in an accident.
- If you see steam or smoke coming from the engine compartment, to avoid injury do not open the hood.

## LIFT GATE

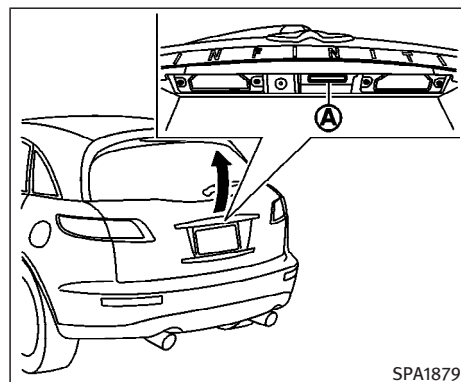

- The power door lock system allows you to lock or unlock all doors including the lift gate simultaneously.
- Push the opener switch (A) and pull the opener handle to open the lift gate.



### WARNING

Do not drive with the lift gate open. This could allow dangerous exhaust gases to be drawn into the vehicle. See “Precautions

when starting and driving” in the “5. Starting and driving” section for exhaust gas.

## AUTO CLOSURE

If the lift gate is pulled down to a partly open position, the lift gate will pull itself to the closed position.

**Do not apply excessive force when the auto closure is operating. Excessive force applied may cause the mechanism to malfunction.**



## CAUTION

- The lift gate will automatically close from a partly open position. To avoid pinching, keep hands and fingers away from lift gate opening.
- Do not let children operate the lift gate.

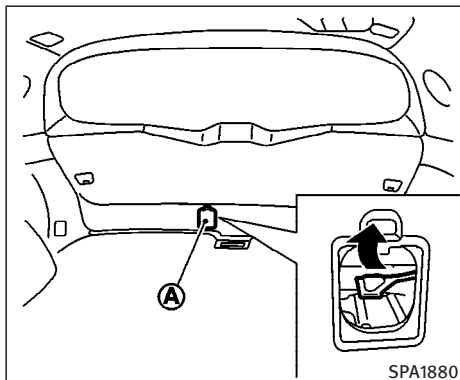

## Lift gate release lever

If the lift gate cannot be opened with the door lock switch due to a discharged battery, follow the these steps.

1. Remove the cover (A) inside of the lift gate.
2. Move the lever as illustrated to open the lift gate.

Contact an INFINITI dealer as soon as possible for repair.



## WARNING

- Always be sure the lift gate has been closed securely to prevent it from opening while driving.
- Do not drive with the lift gate open. This could allow dangerous exhaust gases to be drawn into the vehicle.

## FUEL-FILLER DOOR

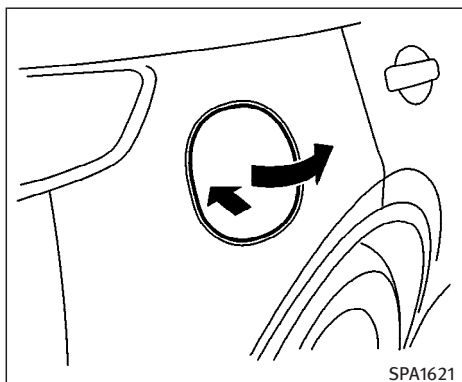

- Push the power door lock switch to the unlock side.

To lock, close the fuel-filler door and lock the doors.

## OPEN THE FUEL-FILLER DOOR

To open the fuel-filler door, unlock it using one of the following operations, then push the left-hand side of the lid.

- Push the unlock button on the keyfob or Intelligent Key once.
- Push the driver's door handle request switch once.
- Insert the metal key into the door lock cylinder and turn the door key clockwise twice.

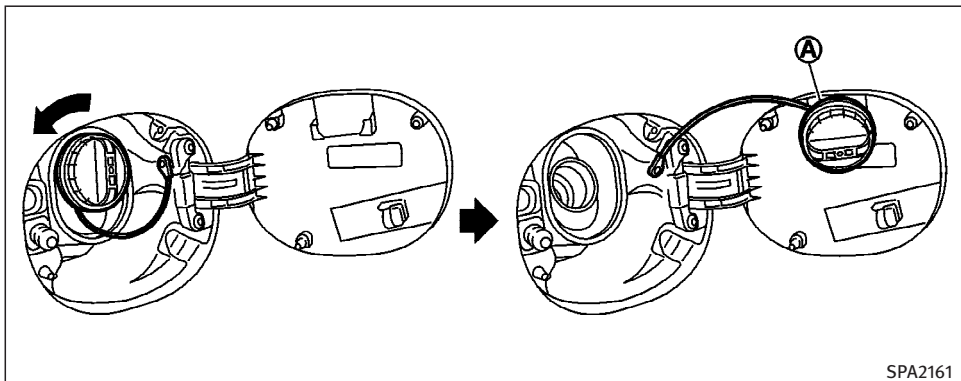

SPA2161

## FUEL-FILLER CAP

The fuel-filler cap is a ratcheting type. Tighten the cap clockwise until ratcheting clicks are heard.

Put the fuel-filler cap (A) on the cap holder while refueling.



### WARNING

- Gasoline is extremely flammable and highly explosive under certain conditions. You could be burned or seriously

injured if it is misused or mishandled. Always stop the engine and do not smoke or allow open flames or sparks near the vehicle when refueling.

- Fuel may be under pressure. Turn the cap a quarter of a turn, and wait for any hissing sound to stop to prevent fuel from spraying out and possibly causing personal injury. Then remove the cap.
- Do not attempt to top off the fuel tank after the fuel pump nozzle shuts off auto-

matically. Continued refueling may cause fuel overflow, resulting in fuel spray and possibly a fire.

- Use only an original equipment type fuel-filler cap as a replacement. It has a built-in safety valve needed for proper operation of the fuel system and emission control system. An incorrect cap can result in a serious malfunction and possible injury. It could also cause the SERVICE ENGINE SOON malfunction indicator lamp to come on.
- Never pour fuel into the throttle body to attempt to start your vehicle.
- Do not fill a portable fuel container in the vehicle or trailer. Static electricity can cause an explosion of flammable liquid, vapor or gas in any vehicle or trailer. To reduce the risk of serious injury or death when filling portable fuel containers:
  - Always place the container on the ground when filling.
  - Do not use electronic devices when filling.
  - Keep the pump nozzle in contact with the container while you are filling it.

- Use only approved portable fuel containers for flammable liquid.



## CAUTION

- If fuel is spilled on the vehicle body, flush it away with water to avoid paint damage.
- Tighten until the fuel-filler cap clicks. Failure to tighten the fuel-filler cap properly may cause the SERVICE ENGINE SOON malfunction indicator lamp (MIL) to illuminate. If the SERVICE ENGINE SOON lamp illuminates because the fuel-filler cap is loose or missing, tighten or install the cap and continue to drive the vehicle. The SERVICE ENGINE SOON lamp should turn off after a few driving trips. If the SERVICE ENGINE SOON lamp does not turn off after a few driving trips, have the vehicle inspected by an INFINITI dealer.
- For additional information, see the “Malfunction indicator lamp (MIL)” in the “2.Instruments and controls” section.

## TILTING TELESCOPIC STEERING COLUMN

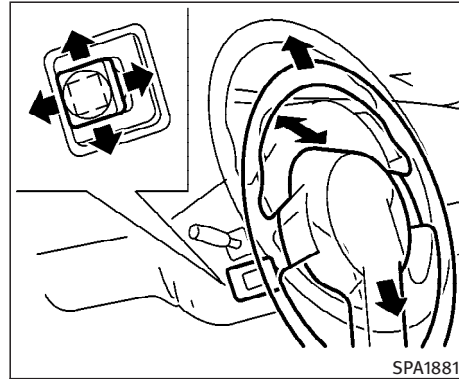

## WARNING

Do not adjust the steering wheel any closer to you than is necessary for proper steering operation and comfort. The driver's air bag inflates with great force. If you are unrestrained, leaning forward, sitting sideways or out of position in any way, you are at greater risk of injury or death in a crash. You may also receive serious or fatal injuries from

the air bag if you are up against it when it inflates. Always sit back against the seatback and as far away as practical from the steering wheel. Always use the seat belts.



## AUTOMATIC OPERATION



### WARNING

Do not adjust the steering wheel while driving. You could lose control of your vehicle and cause an accident.

## Tilt operation

Push the lever to adjust the steering wheel up or down to the desired position.

## Entry/Exit function

The automatic drive positioner system will make the steering wheel move up automatically. This lets the driver get into and out of the seat more easily. See “Automatic drive positioner” later in this section.

## Telescopic operation

Push the lever to adjust the steering wheel forward or backward to the desired position.

## SUN VISORS

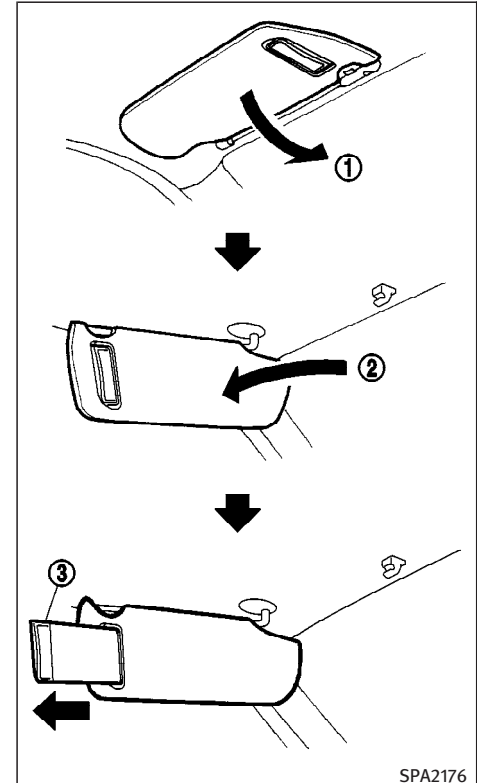

SPA2176

## CAUTION

- Do not store the main sun visor before storing the extension sun visor.
- Do not pull the extension sun visor forcibly downward.

1. To block out glare from the front, swing down the main sun visor ①.
2. To block glare from the side, remove the main sun visor from the center mount and swing it to the side ②.
3. Draw out the extension sun visor ③ from the main sun visor to block from farther glare.

## MIRRORS

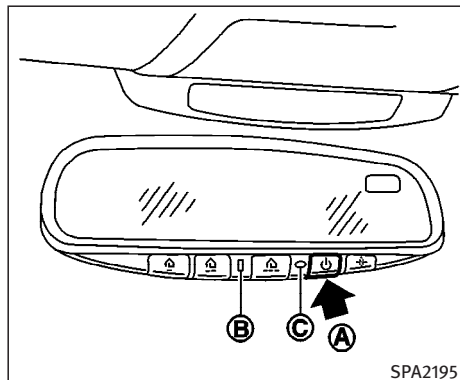

Type A

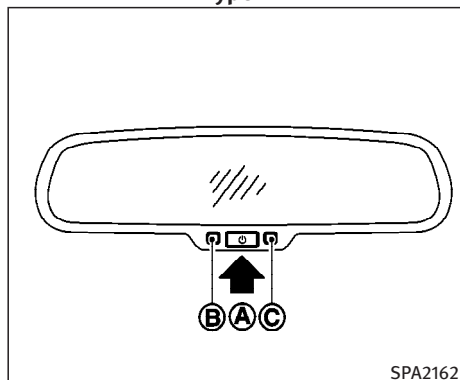

Type B

## AUTOMATIC ANTI-GLARE INSIDE MIRROR

### WARNING

Use automatic anti-glare only when necessary because it reduces rear view clarity.

The inside mirror is designed so that it automatically changes reflection according to the intensity of the headlights of the vehicle following you.

### Type A:

When the inside MIRROR switch ① is in the ON position (The Auto indicator light ② will illuminate), excessive glare from the headlights of the vehicle behind you will be reduced. Push the MIRROR switch ① to turn the system off (the indicator light goes off), and the inside mirror will operate normally.



To turn on the system again, push the MIRROR switch once again.

For the HomeLink® Universal Transceiver and the compass display, see the description in the “2. Instruments and controls” section.

## Type B:

The anti-glare system will be automatically turned on when you turn the ignition switch to the “ON” position.

When the system is turned on, the indicator light **B** will illuminate and excessive glare from the headlights of the vehicle behind you will be reduced.

Push the  switch for 3 seconds to make the inside mirror operate normally, and the indicator light will go off. Push the  switch again for 3 seconds to turn the system on.

**Do not hang any object on the mirror or apply glass cleaner. Doing so will reduce the sensitivity of the sensor **C**, resulting in improper operation.**

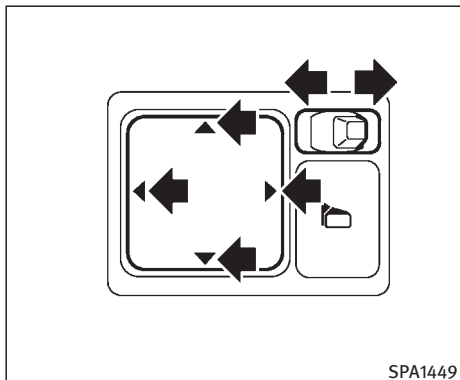

The outside mirror will operate only when the ignition switch is in the ACC or ON position.

Move the switch to right or left to select the right or left outside mirror, then adjust.

## Defrosting outside mirrors

The outside mirrors will be heated when the rear window defroster switch is operated.

## OUTSIDE MIRRORS



### WARNING

**Objects viewed in the outside mirror on the passenger side are closer than they appear. Be careful when moving to the right. Using only this mirror could cause an accident. Use the inside mirror or glance over your shoulder to properly judge distances to other objects.**

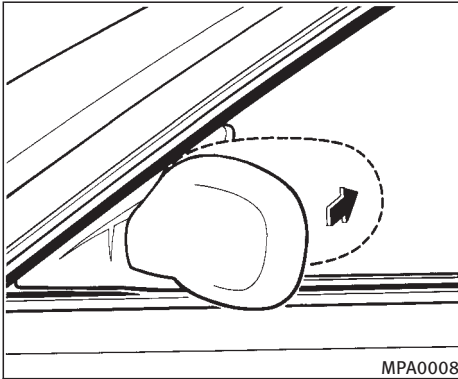

### Foldable outside mirrors

Fold the outside mirrors by pushing them towards the rear of the vehicle.

## AUTOMATIC DRIVE POSITIONER

The automatic drive positioner system has two features:

- Memory storage function
- Entry/exit function

### MEMORY STORAGE FUNCTION

Two positions for the driver's seat, steering column, and outside mirrors can be stored in the automatic drive positioner memory. Follow these procedures to use the memory system.

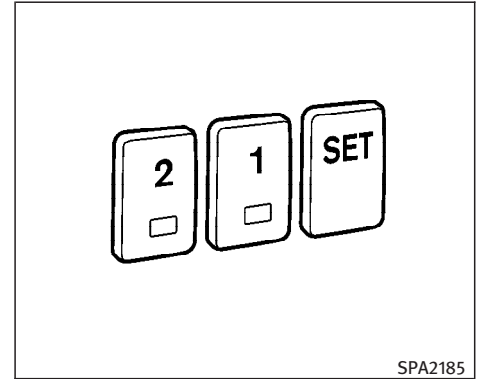

1. Apply the parking brake, and set the selector lever to the P (Park) position.
2. Turn the ignition ON.
3. Adjust the driver's seat, steering column and outside mirrors to the desired positions by manually operating each adjusting switch. For additional information, see "Seats" in the "1. Safety – Seats, seat belts and supplemental restraint system" section and "Steering wheel" and "Outside mirrors" earlier in this section. During this step, do not turn the ignition to any positions other than ON.

4. Push the SET switch and, within 5 seconds, push the memory switch (1 or 2) fully for at least 1 second.

The indicator light for the pushed memory switch will come on and stay on for approximately 5 seconds after pushing the switch. After the indicator light goes off, the selected positions are stored in the selected memory (1 or 2).

If a new memory is stored in the same memory switch, the previous memory will be deleted.

### Linking a keyfob or Intelligent Key to a stored memory position

A keyfob or Intelligent Key can be linked to a stored memory position with the following procedure.

1. Follow the steps for storing a memory position.
2. While the indicator light for the memory switch being set is illuminated for 5 seconds, press the  button on the keyfob or Intelligent Key. The indicator light will blink. After the indicator light goes off, the keyfob or Intelligent Key is linked to that memory setting.

With the key removed from the ignition switch, press the  button on the keyfob or Intelligent Key. The driver's seat, steering wheel and outside mirrors will move to the memorized position.

### Confirming memory storage

- Turn the ignition ON and push the SET switch. If the main memory has not been stored, the indicator light will come on for approximately 0.5 seconds. When the memory has stored the position, the indicator light will stay on for approximately 5 seconds.
  - If the battery cable is disconnected, or if the fuse opens, the memory will be canceled. In such a case, reset the desired positions using the following procedures.
1. Open and close the driver's door more than two times with the ignition key in the LOCK position.
  2. Reset the desired position using the previous procedure.

### Selecting the memorized position

1. Set the selector lever to the P (Park) position.

2. Turn the ignition ON.
3. Push the memory switch (1 or 2) fully for at least 1 second.

The driver's seat, steering column and outside mirrors will move to the memorized position with the indicator light flashing, and then the light will stay on for approximately 5 seconds.

### ENTRY/EXIT FUNCTION

This system is designed so that the driver's seat, steering column and door mirrors will automatically move when the automatic transmission selector lever is in the P (Park) position. This allows the driver to get into and out of the driver's seat more easily.

The driver's seat will slide backward and the steering wheel will move up:

- When the driver's door is opened after removing the key from the ignition switch or the ignition switch (if so equipped), or returning the ignition switch to lock position.
- When the driver's door is opened with the key turned to LOCK.
- When the key is turned from ACC to LOCK or returning the ignition switch to

lock position with the driver's door open.

The driver's seat and steering wheel will return to the previous position:

- When the key is inserted into the ignition switch or the ignition switch (if so equipped) is pushed in after closing the door.
- When the driver's door is closed with the key turned to LOCK.
- When the key or the ignition switch is turned from ACC to ON with the driver's door open.

The entry/exit feature can be adjusted or canceled. See "Vehicle electronic systems" in the "4. Display screen, heater, air conditioner and audio systems" section of this manual.

### Initialize entry/exit function

If the battery cable is disconnected, or if the fuse opens, the entry/exit function will not work even if it has been set. After reconnecting the battery or replacing the fuse, open and close the driver's door several times after inserting the electronic key into the ignition switch. The entry/exit function will be activated.

### 3-34 Pre-driving checks and adjustments

## System operation

The automatic drive positioner system will not work or will stop operating under the following conditions:

- when the vehicle speed is above 4 MPH (7 km/h).
- when any two or more of the memory switches are simultaneously pushed while the automatic drive positioner is operating.
- when the adjusting switch for the driver's seat is turned on while the automatic drive positioner is operating.
- when the memory switch 1 or 2 is not pushed for at least 1 second.
- when the seat has been already moved to the memorized position.
- when no seat position is stored in the memory switch.

The automatic drive positioner system can be adjusted and canceled. See "Automatic seat slide in getting off" and "Lift steering column when exiting vehicle" in the "4. Display screen, heater, air conditioner and audio systems" section.

**MEMO**

# 4 Display screen, heater, air conditioner and audio systems

Safety note .....	4-2	Ventilators.....	4-20
How to use INFINITI controller.....	4-2	Heater and air conditioner (Automatic).....	4-21
Start-up screen (model with Navigation system).....	4-3	Automatic operation .....	4-22
Control panel buttons – without navigation system .....	4-4	Manual operation .....	4-23
How to use “TRIP” button .....	4-5	Operating tips .....	4-23
How to use “FUEL ECON” button .....	4-5	In-cabin microfilter (if so equipped) .....	4-24
How to use “E/M” button .....	4-5	Servicing air conditioner .....	4-24
How to use “MAINT” (Maintenance) button.....	4-6	Audio system.....	4-25
Maintenance notice .....	4-6	FM radio reception.....	4-25
How to use the “SETTING” button.....	4-8	AM radio reception .....	4-26
“DAY/NIGHT” button .....	4-11	Satellite radio reception (if so equipped) .....	4-26
Outside air temperature.....	4-11	Audio operation precautions .....	4-27
Control panel buttons – with navigation system .....	4-12	FM-AM-satellite radio with compact disc (CD) changer .....	4-34
How to use the “TRIP” button.....	4-12	CD care and cleaning .....	4-39
Maintenance notice .....	4-14	Steering wheel switch for audio control (if so equipped) .....	4-40
How to use the “SETTING” button.....	4-15	Bluetooth <sup>®</sup> Hands-Free Phone System with INFINITI voice recognition (if so equipped).....	4-41
Rearview monitor (if so equipped) .....	4-18	Using the system .....	4-43
How to read the displayed lines .....	4-19	Control buttons .....	4-45
Adjusting the screen .....	4-19	Getting started .....	4-45
Operating tips .....	4-19	List of voice commands.....	4-47



Speaker adaptation (SA) mode .....	4-53
Troubleshooting guide .....	4-54
INFINITI mobile entertainment system (MES) (if so equipped) .....	4-55
Digital video disc (DVD) player controls .....	4-56
Remote control .....	4-56
Remote control holder .....	4-57

Flip-down screen .....	4-57
Playing a digital video disc (DVD) .....	4-58
Care and maintenance .....	4-62
How to handle the DVD .....	4-62
Antenna .....	4-64
Car phone or CB radio .....	4-65



## SAFETY NOTE



### WARNING

- Positioning of the heating or air conditioning controls and display controls should not be done while driving in order that full attention may be given to the driving operation.
- Do not disassemble or modify this system. If you do, it may result in accidents, fire, or electrical shock.
- Do not use this system if you notice any abnormality, such as a frozen screen or lack of sound. Continued use of the system may result in accident, fire or electric shock.
- In case you notice any foreign objects in the system hardware, spill liquid on it, or notice smoke or smell coming from it, stop using the system immediately and contact an INFINITI dealer. Ignoring such conditions may lead to accident, fire, or electric shock.

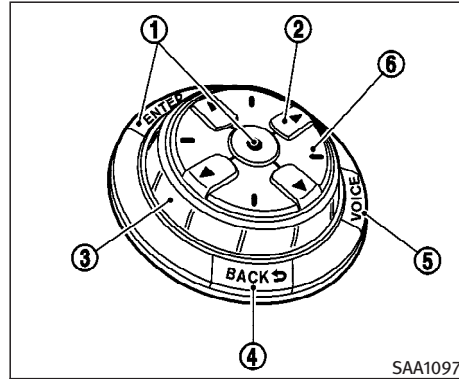

With Navigation system

### HOW TO USE INFINITI CONTROLLER

Choose an item on the display using the main directional buttons (2) (or additional directional buttons (6) with Navigation system) or center dial (3), and push the **ENTER** “ENTER/” button (1) for operation.

If you push the **BACK** “ ” button (4) before the setup is completed, the setup will be canceled and/or the display will return to the previous screen.

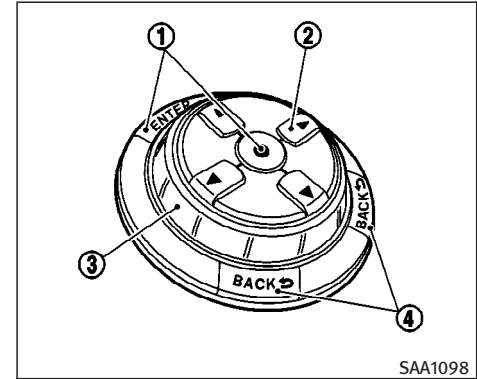

Without Navigation system

After the setup is completed, push the **BACK** “ ” button (4) and return to the previous screen.

For the “VOICE” button (5) functions, refer to the separate Navigation System Owner’s Manual.

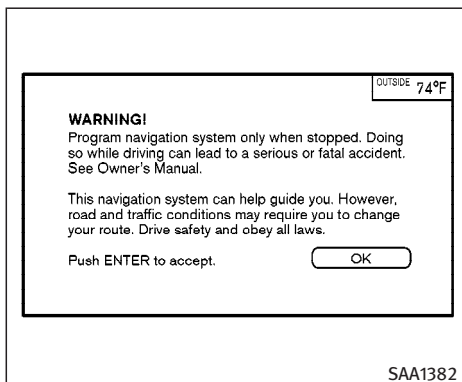

To proceed to the NAVI system, refer to the separate Navigation System Owner's Manual.

## START-UP SCREEN (model with Navigation system)

When you push the ignition switch to the ACC or ON position, the SYSTEM START-UP warning is displayed on the screen. When you read and agree with the warning, push the **ENTER** “” button.

If you do not push the **ENTER** “” button, you will not be able to use the NAVI system.

## CONTROL PANEL BUTTONS – WITHOUT NAVIGATION SYSTEM

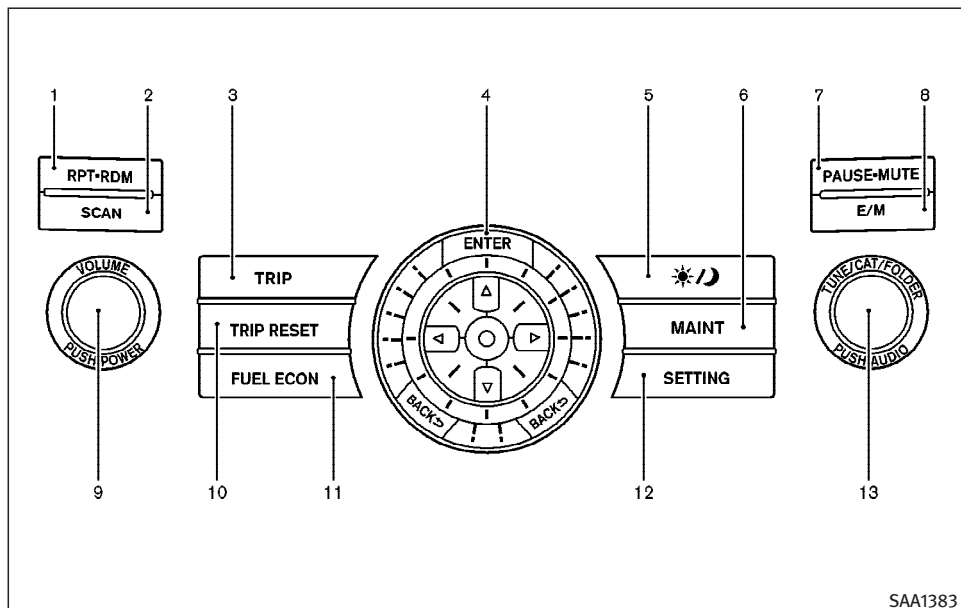

10. “TRIP RESET” button

11. “FUEL ECON” button

12. “SETTING” button

Make sure the engine is running before using this system.

**If you use the system with the engine not running (ignition ON or ACC) for a long time, it will use up all the battery power, and the engine will not start.**

1, 2, 7, 9, 13. For audio system control button (See “AUDIO SYSTEM” later in this section.)

3. “TRIP” button

4. INFINITI controller

5. “DAY/NIGHT” button

6. “MAINT” maintenance button

8. “E/M” button

4-4 Display screen, heater, air conditioner and audio systems

SAA1383

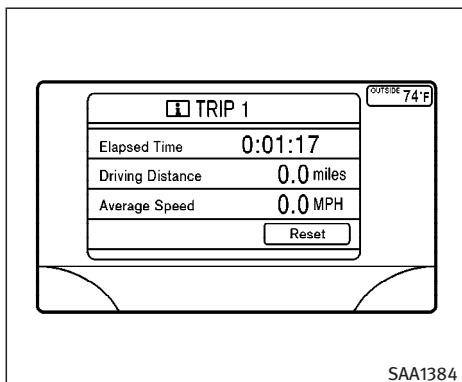

## HOW TO USE “TRIP” BUTTON

When the “TRIP” button is pushed, the following modes will display on the screen.

TRIP 1 (TIME, DIST, AVG) → TRIP 2 (TIME, DIST, AVG) → OFF

Elapsed Time, Driving Distance and Average Speed will be displayed.

To reset, select the “Reset” key using the INFINITI controller and push the **ENTER** “” button, or push the “TRIP RESET” or “TRIP” button for more than approximately 1.5 seconds.

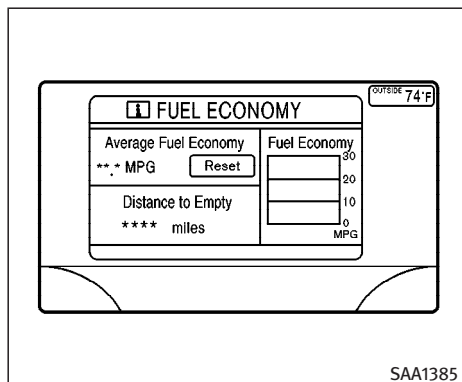

## HOW TO USE “FUEL ECON” BUTTON

Average Fuel Economy and Distance to Empty will be displayed for reference when the “FUEL ECON” button is pushed.

To reset, select the “Reset” key using the INFINITI controller and push the **ENTER** “” button, or push the “TRIP RESET” or “TRIP” button for more than approximately 1.5 seconds.

## HOW TO USE “E/M” BUTTON

You can change the unit as follows using the “E/M” (English/Metric) button.

Unit: US — Mile, °F, MPG  
Metric — km, °C, L/100 km

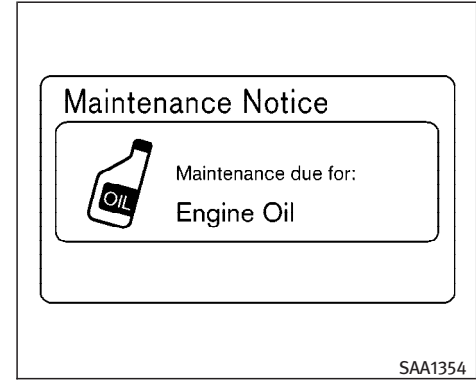
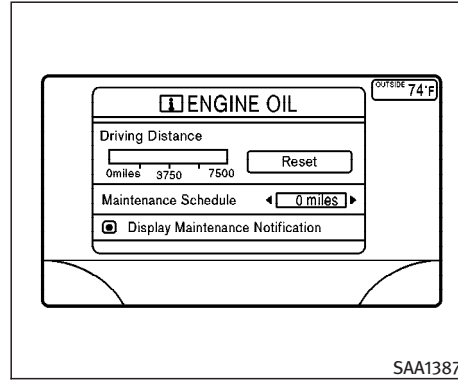
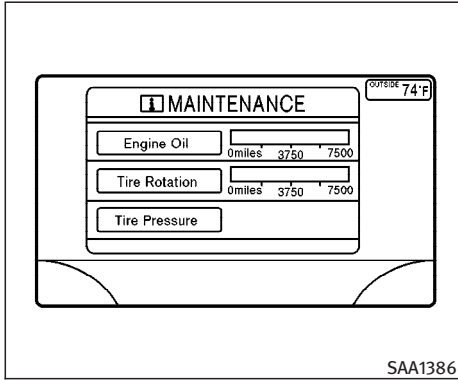

## HOW TO USE “MAINT” (Maintenance) BUTTON

Maintenance and tire pressure information (if so equipped) will be displayed when the “MAINT” button is pushed.

To display the setting of the maintenance interval, select the “Engine Oil” or “Tire Rotation” key using the INFINITI controller and push the **ENTER** “ ” button.

To set the maintenance interval, select the “Maintenance Schedule” key by using the INFINITI controller and move the INFINITI controller to the right or left.

## 4-6 Display screen, heater, air conditioner and audio systems

To reset the maintenance interval, select the “Reset” key using the INFINITI controller and push the **ENTER** “ ” button.

To display the MAINTENANCE NOTICE, automatically when setting trip distance is reached, select the “Display Maintenance Notification” key and push the **ENTER** “ ” button.

## MAINTENANCE NOTICE

The “MAINTENANCE NOTICE” screen (“ENGINE OIL” or “TIRE ROTATION”) will be automatically displayed as shown when both of the following conditions are met:

- the vehicle is driven the set distance and the ignition switch is turned OFF.
- the ignition key is turned ON the next time the vehicle will be driven.

To return to the previous display after the “MAINTENANCE NOTICE” screen is displayed, push the **BACK** “ ” button.

The “MAINTENANCE NOTICE” screen displays each time the key is turned ON until one of the following conditions are met:

- “RESET” is selected.
- “Display Maintenance Notification” is set OFF.
- the maintenance interval is set again.

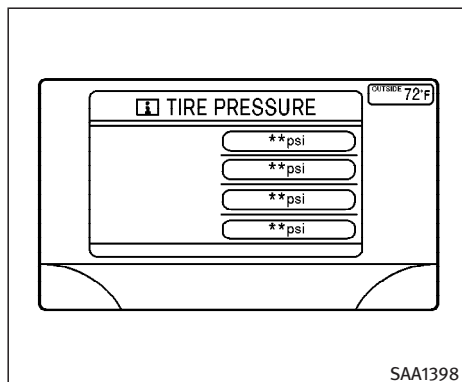

### Tire pressure information (if so equipped)

Pressure indication in \*\* psi on the screen indicates that the pressure is being measured. After a few driving trips, the pressure for each tire will be displayed randomly.

The order of tire pressure figures displayed on the screen does not correspond with the actual order of the tire position.

Tire pressure rises and falls depending on the heat caused by the vehicle’s traveling condition and the temperature.

In case of low tire pressure, a message (FLAT TIRE or CHECK ALL TIRE) is displayed on the screen:

FLAT TIRE — Check all tires.



### WARNING

- When a spare tire is mounted or a wheel is replaced, tire pressure will not be indicated, the Tire Pressure Monitoring System (TPMS) will not function and the low tire pressure warning light will flash. Contact your INFINITI dealer as soon as possible for tire replacement and/or system resetting.
- Replacing tires with those not originally specified by INFINITI could affect the proper operation of the TPMS.

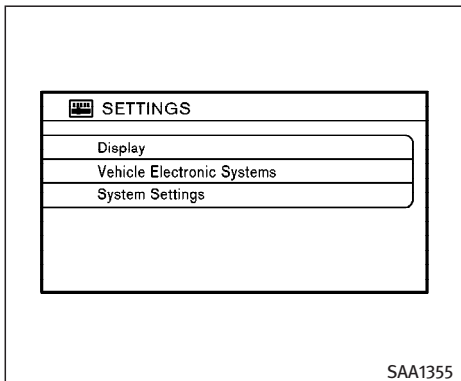

## HOW TO USE THE “SETTING” BUTTON

The SETTINGS screen will appear when the “SETTING” button is pushed.

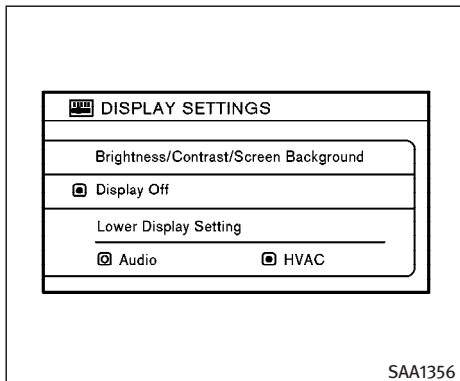

## “Display” settings

The DISPLAY SETTINGS screen will appear when selecting the “Display” key and pushing the **ENTER** “” button.

### Brightness/Contrast/Screen Background:

To adjust the brightness and contrast of the screen, select the “Brightness/Contrast/Screen Background” key and push the **ENTER** “” button. Then you can adjust the brightness to Darker or Brighter, the contrast to Lower or Higher using the INFINITI controller.

## Display Off:

To turn off the screen, push the “SETTING” button and select the “Display” key and “Display Off” key. The indicator of the “Display Off” will turn on. When any mode button is pushed with the screen off, the screen turns on for further operation. The screen will turn off automatically 5 seconds after the operation is finished.

To turn on the screen, push the “SETTING” button and select the “Display” key and “Display Off” key, then set the screen to on by pushing the **ENTER** “” button.

### Setting Audio or HVAC display:

Choose the “Audio” or “HVAC” (Heater and air conditioner) key to be displayed at the bottom, by using the INFINITI controller. The audio or HVAC (heater, air conditioner) setting condition will normally appear on the screen.

To return to the setting screen, push the “SETTING” button or **BACK** “” button.



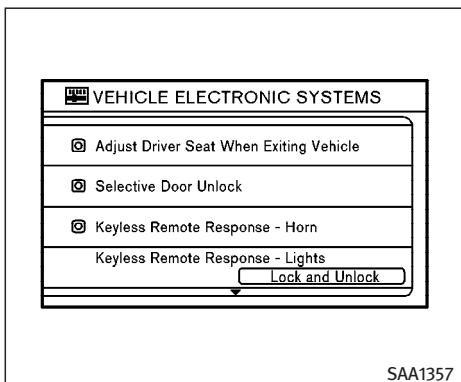

## Vehicle electronic systems

The VEHICLE ELECTRONIC SYSTEMS screen will appear when selecting the “Vehicle Electronic Systems” key with the INFINITI controller and pushing the **ENTER** “ ” button.

You can set the various electronic systems operating conditions.

To set an operating condition, select the applicable item using the INFINITI controller, and push the **ENTER** “ ” button.

The indicator light alternately turns on and off each time the **ENTER** “ ”

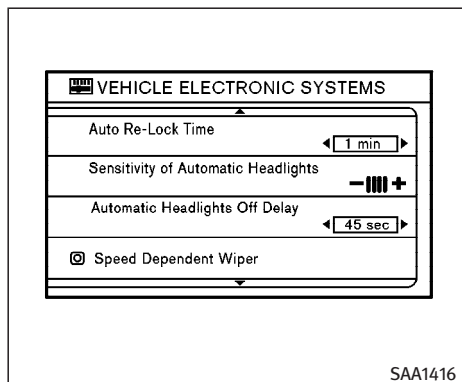

button is pushed.

Indicator light is illuminated. — ON

Indicator light is not illuminated. — OFF

### Adjust driver seat when exiting vehicle:

The driver’s seat automatically moves back and returns to the original position for ease of exit and entry.

### Selective door unlock:

This key can switch the unlock doors of the 1st unlocking operation as follows:

ON (Only the driver side door)  $\longleftrightarrow$  OFF (All the doors)

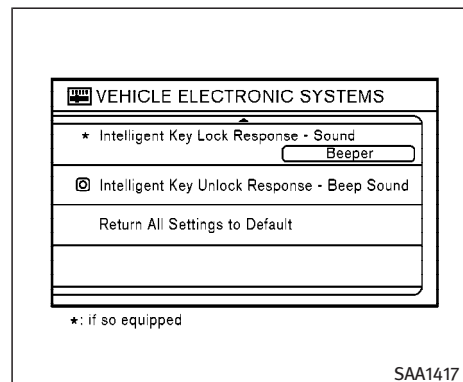

### Keyless Remote Response — Horn\*:

This key changes the horn chirp mode that occurs when pushing the “LOCK” button on the keyfob or the Intelligent Key.

### Keyless Remote Response — Lights\*:

This key changes the hazard indicator flash mode that occurs when pushing the “LOCK” or “UNLOCK” button on the keyfob or the Intelligent Key.

\* **Even if you change the horn chirp or the hazard flash with the keyfob or the Intelligent Key, the change may not be re-**

flected in the display. Use the keyfob or the Intelligent Key to return to the previous mode.

#### Auto Re-Lock Time:

The length of the auto door re-lock time can be set. Select the “Auto Re-Lock Time” key, then move the INFINITI controller and push the **ENTER** “” button to adjust the time.

#### Sensitivity of Automatic Headlights:

Automatic light illumination can be set as desired.

Select the “Sensitivity of Automatic Headlights” key, then move the INFINITI controller to the left (lower) or right (higher).

#### Automatic Headlights Off Delay:

You can control how long it takes the automatic turn off timer to extinguish the headlights in the AUTO position.

Select the “Automatic Headlights Off Delay” key, then move the INFINITI controller to the left or right to adjust the timer.

#### Speed Dependent Wiper:

When this item is turned to on, the wiper interval is adjusted automatically according to the vehicle speed.

#### Intelligent Key Lock Response — Sound (if so equipped):

The sound pattern of the Intelligent request switch operation can be set as desired. Select the “Intelligent Key lock response — Sound” key, then push the **ENTER** “” button to change the sound pattern.

#### Intelligent Key Unlock Response — Beep Sound (if so equipped):

The beep sounds when unlocking door with the Intelligent request switch can be turned on or off.

#### Return All Settings to Default:

When this key is selected and turned on using the **ENTER** “” button, all settings made by VEHICLE ELECTRONICS will return to the initial conditions.

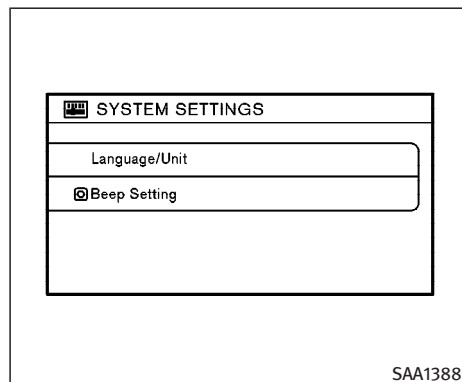

#### System settings

##### Language/Unit:

The LANGUAGE/UNIT screen will appear when selecting the “Language/Unit” key and pushing the **ENTER** “” button.

Language: English or French

Unit: US — Mile, °F, MPG  
Metric — km, °C, L/100 km

You can select the language and unit using the INFINITI controller and **ENTER** “” button.

## “DAY/NIGHT” BUTTON

To change the display brightness, push the “DAY/NIGHT” button. Pushing the button again will change the display to DAY or NIGHT display. Then, adjust the brightness moving the INFINITI controller right or left.

If no operation is done within 10 seconds, or if the **BACK** “” button is pushed, the display will return to the previous display.

Pushing the “DAY/NIGHT” button for more than approximately 1.5 seconds will turn the display off. The screen will change to “CONFIRM DISPLAY OFF YES or NO”.

## OUTSIDE AIR TEMPERATURE

The outside air temperature is displayed in °F or °C.

It may differ from the actual outside air temperature due to the sensor location.

## CONTROL PANEL BUTTONS – WITH NAVIGATION SYSTEM

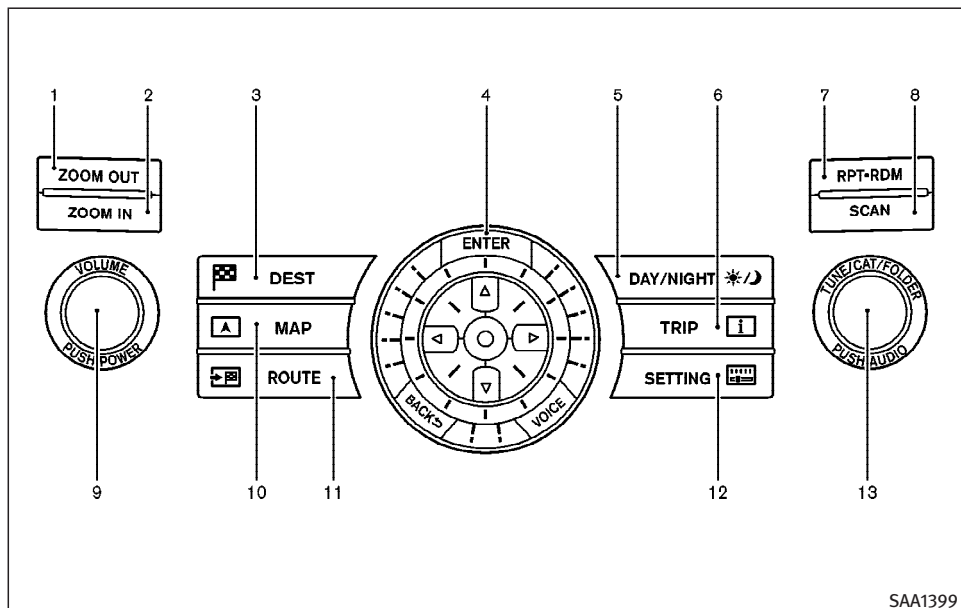

1, 2, 3, 10, 11. For Navigation system control buttons; refer to the separate Navigation System Owner's Manual.

5. "DAY/NIGHT" button

4-12 Display screen, heater, air conditioner and audio systems

6. "TRIP" button

7, 8, 9, 13. For audio system control buttons; refer to "AUDIO SYSTEM" later in this section.

12. "SETTING" button

When you use this system, make sure the engine is running.

**If you use the system with the engine not running (ignition ON or ACC) for a long time, it will use up all the battery power, and the engine will not start.**

### HOW TO USE THE "TRIP" BUTTON

When the "TRIP" button is pushed, the following modes will display on the screen.

Warning message (if there are any) → TRIP 1 → TRIP 2 → FUEL ECONOMY → MAINTENANCE.

SAA1399

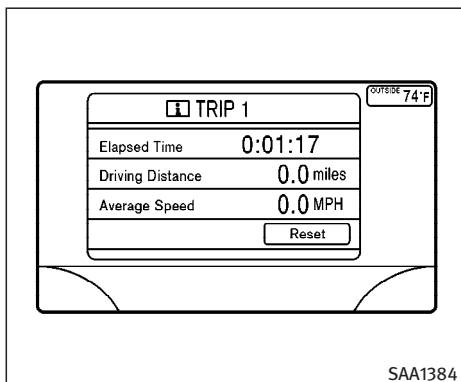

### “TRIP” information

Elapsed Time, Driving Distance and Average Speed will be displayed.

To reset, select the “Reset” key using the INFINITI controller and push the **ENTER** “” button or push the “TRIP” button for more than approximately 1.5 seconds.

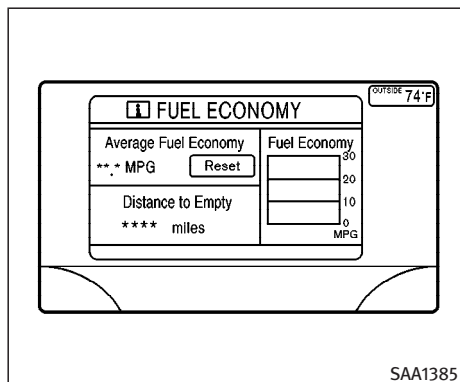

### “FUEL ECONOMY” information

Average Fuel Economy and Distance to Empty will be displayed for reference.

To reset, select the “Reset” key using the INFINITI controller and push the **ENTER** “” button or push the “TRIP” button for more than approximately 1.5 seconds.

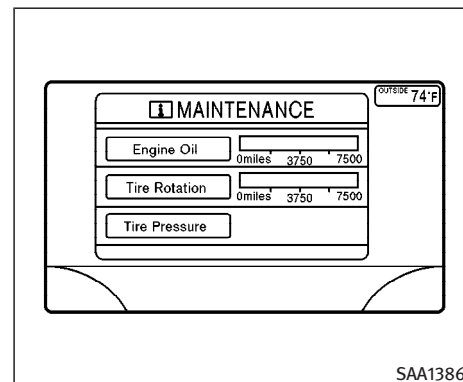

### “MAINTENANCE” information

You can set the engine oil and the tire rotation interval.

And the tire pressure will appear on the screen (if the tire pressure system is equipped).

To display the setting of the maintenance interval, select the “Engine Oil” or “Tire Rotation” key using the INFINITI controller and push the **ENTER** “” button.

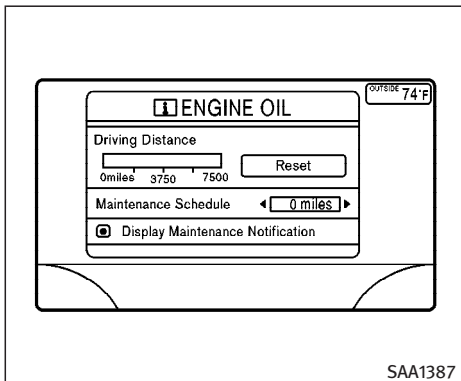

To set the maintenance interval, select the “Maintenance Schedule” key by using the INFINITI controller and move the INFINITI controller to the right or left.

To reset the maintenance interval, select the “Reset” key using the INFINITI controller and push the **ENTER** “” button.

To display the MAINTENANCE NOTICE, automatically when setting trip distance is reached, select the “Display Maintenance Notification” key and push the **ENTER** “” button.

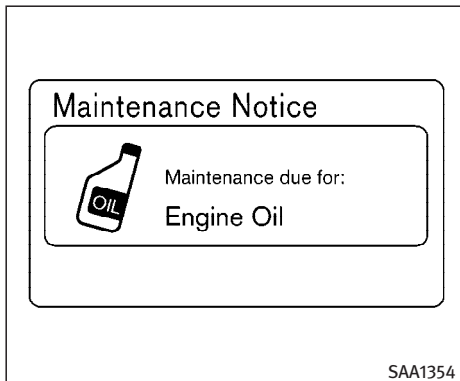

## MAINTENANCE NOTICE

The “MAINTENANCE NOTICE” screen (“ENGINE OIL” or “TIRE ROTATION”) will be automatically displayed as shown when both of the following conditions are met:

- the vehicle is driven the set distance and the ignition switch is turned OFF.
- the ignition key is turned ON the next time the vehicle will be driven.

To return to the previous display after the “MAINTENANCE NOTICE” screen is displayed, push the **BACK** “” button.

The “MAINTENANCE NOTICE” screen displays each time the key is turned ON until one of the following conditions are met:

- “RESET” is selected.
- “Display Maintenance Notification” is set OFF.
- the maintenance interval is set again.

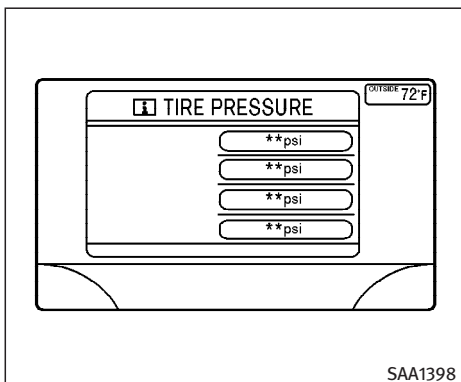

SAA1398

## Tire pressure information (if so equipped)

To view “TIRE PRESSURE” information, push the “TRIP” button repeatedly until the “MAINTENANCE” screen is displayed. Select “TIRE PRESSURE” using the INFINITI controller and push the **ENTER** “” button.

Pressure indication in \*\* psi on the screen indicates that the pressure is being measured. After a few driving trips, the pressure for each tire will be displayed randomly.

The order of tire pressure figures displayed on the screen does not correspond with the actual order of the tire position.

Tire pressure rises and falls depending on the heat caused by the vehicle’s traveling condition and the temperature.

In case of low tire pressure, a message is displayed on the screen:

FLAT TIRE — Check all tires.



## WARNING

- When a spare tire is mounted or a wheel is replaced, tire pressure will not be indicated, the TPMS will not function and the low tire pressure warning light will flash. Contact your INFINITI dealer as soon as possible for tire replacement and/or system resetting.
- Replacing tires with those not originally specified by INFINITI could affect the proper operation of the TPMS.

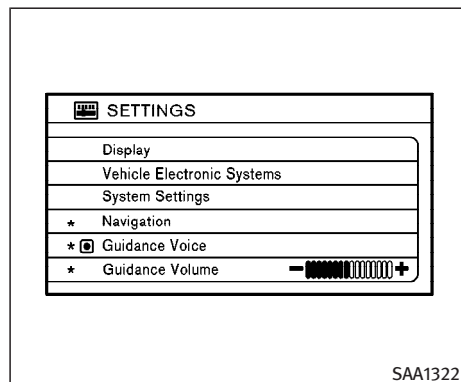

SAA1322

\* — Refer to the separate Navigation System Owner’s Manual.

## HOW TO USE THE “SETTING” BUTTON

The SETTINGS screen will appear when the “SETTING” button is pushed.

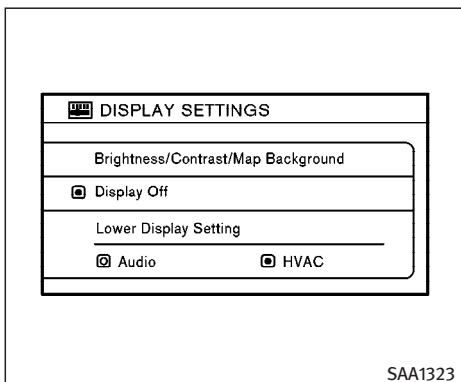

## “Display” settings

The DISPLAY SETTINGS screen will appear when selecting the “Display” key and pushing the ENTER “” button.

### Brightness/Contrast/Map Background:

To adjust the brightness and contrast of the screen, select the “Brightness/Contrast/Map Background” key and push the ENTER “” button. Then you can adjust the brightness to Darker or Brighter, the contrast to Lower or Higher using the INFINITI controller.

The Map Background is related to the navigation system. Refer to the separate Navigation System Owner’s Manual.

### Display Off:

To turn off the screen, push the “SETTING” button and select the “Display” key and “Display Off” key. The indicator of the “Display Off” will turn on. When any mode button is pushed with the screen off, the screen turns on for further operation. The screen will turn off automatically 5 seconds after the operation is finished on the map display in the Audio, HVAC (Heater and air conditioner).

To turn on the screen, push the “SETTING” button and select the “Display” key and “Display Off” key, then set the screen to on by pushing the ENTER “” button.

### Setting Audio or HVAC display:

Choose the “Audio” or “HVAC” (Heater and air conditioner) key to be displayed at the bottom, by using the INFINITI controller. The audio or HVAC (heater, air conditioner) setting condition will normally appear on the screen.

To return to the setting screen, push the “SETTING” button or BACK “” button.

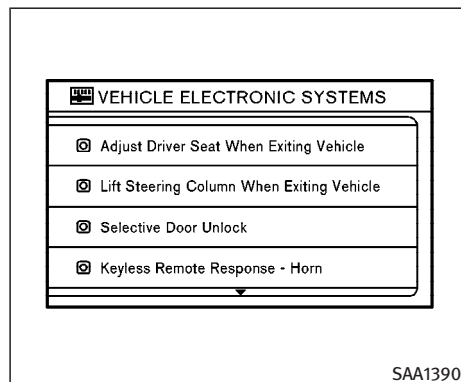

## Vehicle electronic systems

The VEHICLE ELECTRONIC SYSTEMS screen will appear when selecting the “Vehicle Electronic Systems” key with the INFINITI controller and pushing the ENTER “” button.

You can set the various electronic systems operating conditions.

To set an operating condition, select the applicable item using the INFINITI controller, and push the ENTER “” button.

The indicator light alternately turns on and off each time the ENTER “”



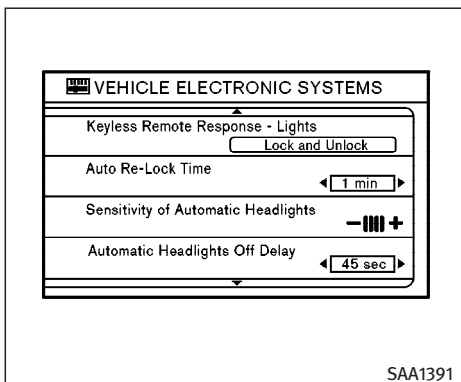

button is pushed.

Indicator light is illuminated. — ON

Indicator light is not illuminated. — OFF

#### Adjust driver seat when exiting vehicle:

The driver's seat automatically moves back and returns to the original position for ease of exit and entry.

#### Lift steering column when exiting vehicle:

The steering column automatically tilts up and returns to the original position for exceptional ease of entry and exit.

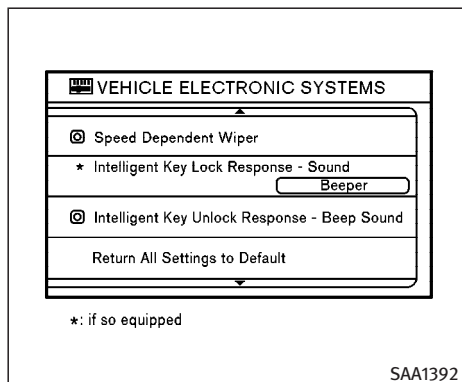

#### Selective door unlock:

This key can switch the unlock doors of the 1st unlocking operation as follows:

ON (Only the driver side door) ←→ OFF (All the doors)

#### Keyless Remote Response — Horn\*:

This key changes the horn chirp mode that occurs when pushing the “LOCK” button on the keyfob or the Intelligent Key.

#### Keyless Remote Response — Lights\*:

This key changes the hazard indicator flash mode that occurs when pushing the

“LOCK” or “UNLOCK” button on the keyfob or the Intelligent Key.

\* Even if you change the horn chirp or the hazard flash with the keyfob or the Intelligent Key, the change may not be reflected in the display. Use the keyfob or the Intelligent Key to return to the previous mode.

#### Auto Re-Lock Time:

The length of the auto door re-lock time can be set. Select the “Auto Re-Lock Time” key, then move the INFINITI controller and push the ENTER “ENTER/ⓐ” button to adjust the time.

#### Sensitivity of Automatic Headlights:

Automatic light illumination can be set as desired.

Select the “Sensitivity of Automatic Headlights” key, then move the INFINITI controller to the left (lower) or right (higher).

#### Automatic Headlights Off Delay:

You can control how long it takes the automatic turn off timer to extinguish the headlights in the AUTO position.

Select the “Automatic Headlights Off Delay” key, then move the INFINITI controller to the left or right to adjust the timer.

### Speed Dependent Wiper:

When this item is turned to on, the wiper interval is adjusted automatically according to the vehicle speed.

### Intelligent Key Lock Response — Sound (if so equipped):

The sound pattern of the Intelligent request switch operation can be set as desired. Select the “Intelligent Key lock response — Sound” key, then push the ENTER “” button to change the sound pattern.

### Intelligent Key Unlock Response — Beep Sound (if so equipped):

The beep sounds when unlocking door with the Intelligent request switch can be turned on or off.

### Return All Settings to Default:

When this key is selected and turned on using the ENTER “” button, all settings made by VEHICLE ELECTRONIC SYSTEMS will return to the initial conditions.

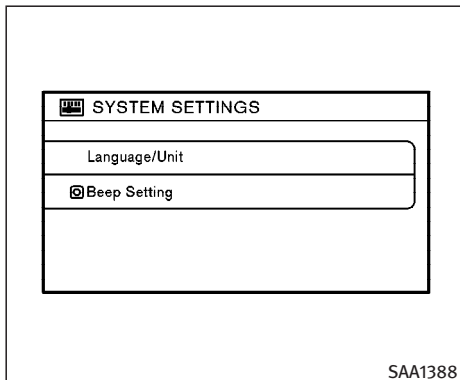

## System settings

### Language/Unit:

The LANGUAGE/UNIT screen will appear when selecting the “Language/Unit” key and pushing the ENTER “” button.

Language: English or French

Unit: US — Mile, °F, MPG  
Metric — km, °C, L/100 km

You can select the language and unit using the INFINITI controller and ENTER “” button.

## REARVIEW MONITOR (if so equipped)

When the selector lever is shifted into the R (Reverse) position, the monitor display shows view to the rear of the vehicle.

The system is designed as an aid to the driver in detecting large stationary objects to help avoid damaging the vehicle. The system will not detect small objects below the bumper, and may not detect objects close to the bumper or on the ground.



## CAUTION

- The rearview camera is a convenience but it is not a substitute for proper backing. Always turn and check that it is safe to do so before backing up. Always back up slowly.
- Objects viewed in the rearview monitor differ from actual distance because a wide-angle lens is used. Objects in the rearview monitor will appear visually opposite than when viewed in the rearview and outside mirrors.
- Make sure that the lift gate is securely closed when backing up.

- Do not put anything on the rearview camera. The rearview camera is installed beside the license plate light.
- When washing the vehicle with high-pressure water, be sure not to spray it around the camera. Otherwise, water may enter the camera unit causing water condensation on the lens, a malfunction, fire or an electric shock.
- Do not strike the camera. It is a precision instrument. Otherwise, it may malfunction or cause damage resulting in a fire or an electric shock.
- Do not use alcohol, benzine or thinner to clean the camera. This will cause discoloration.
- There is a plastic cover over the camera. Do not scratch the cover when cleaning dirt or snow from it.

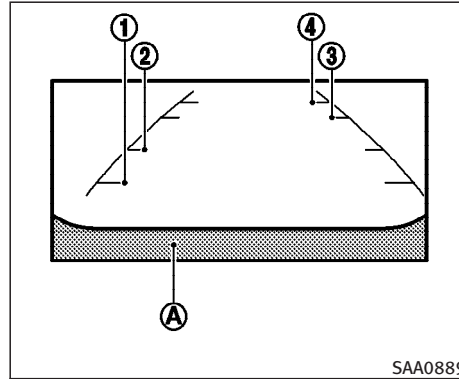

### HOW TO READ THE DISPLAYED LINES

Lines which indicate the vehicle clearance and distances to objects with reference to the bumper line (A) are displayed on the monitor.

They are indicated as reference distances to objects. Displayed lines indicate distances 1.5 feet (red) (1), 3 feet (yellow) (2), 7 feet (green) (3) and 10 feet (green) (4) [0.5 m (red), 1 m (yellow), 2 m (green) and 3 m (green)] from the lower part of the bumper line (A).

**The vehicle clearance lines are wider than the actual clearance.**

### ADJUSTING THE SCREEN

To adjust the quality of the screen, refer to “HOW TO USE THE “SETTING” BUTTON” in this section.

### OPERATING TIPS

- When the selector lever is shifted to R, the display screen automatically changes to the rearview monitor mode. However, the radio can be heard.
- It may take some time for the rearview monitor to display after the selector lever has been shifted to R. Objects may be distorted momentarily. When the selector lever is returned to a position other than R, it may take some time for the screen to change. Objects on the screen may be distorted until they are completely displayed.
- When the temperature is extremely high or low, the screen may not clearly display objects. This is not a malfunction.
- When strong light directly enters the camera, objects may not be displayed clearly.

## VENTILATORS

- Vertical lines may be seen in objects on the screen. This is due to strong reflected light from the bumper. This is not a malfunction.
- The screen may flicker under fluorescent light. This is not a malfunction.
- The colors of objects on the rear view monitor may differ somewhat from those of the actual object.
- When the contrast of objects is low at night, pushing the **ENTER** “**ENTER/**” button may not change the brightness.
- Objects on the monitor may not be clear in a dark place or at night.
- If dirt, rain or snow attaches to the camera, the rear view monitor may not clearly display objects. Clean the camera.
- To clean the camera, wipe with a cloth dampened with diluted mild cleaning agent and then wipe with a dry cloth.
- Do not use body wax on the camera window. Wipe off any wax with a clean cloth dampened with mild detergent diluted with water.

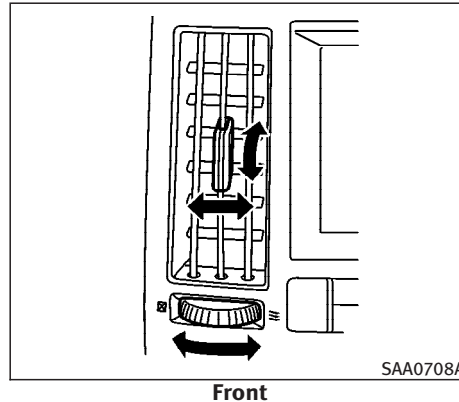

Open or close, and adjust the air flow direction of ventilators.

☒ : This symbol indicates that the vents are closed.

≡ : This symbol indicates that the vents are open.

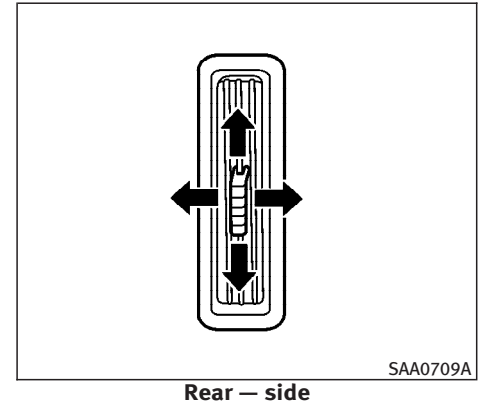

## HEATER AND AIR CONDITIONER (Automatic)

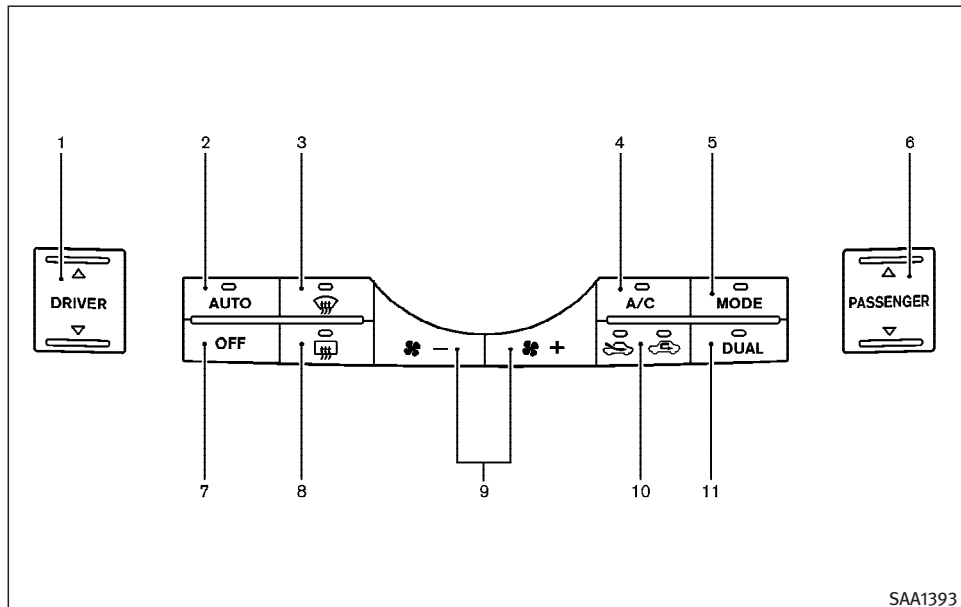

7. "OFF" button for climate control system
8. " [defroster icon] " rear window defroster button; refer to the "2. Instrument and controls" section.
9. Fan speed control button
10. " [car icon] [car icon] " intake air control button
11. "DUAL" passenger side temperature control "ON/OFF" button

1. Temperature control button (driver only, or driver and passenger)
2. "AUTO" climate control "ON" button
3. " [defroster icon] " front defroster button
4. "A/C" air conditioner "ON/OFF" button
5. "MODE" manual air flow control button
6. Temperature control button (passenger side)



## WARNING

- The air conditioner cooling function operates only when the engine is running.
- On hot, sunny days, temperatures in a closed vehicle could quickly become high enough to cause severe or possibly fatal injuries to people or animals. Do not leave children or adults who would normally require the assistance of others in your vehicle. Unattended pets should also not be left alone.
- Do not use the recirculation mode for long periods as it may cause the interior air to become stale and the windows to fog up.
- Positioning of the heater and/or air conditioner controls should not be done while driving, so full attention may be given to vehicle operation.

Start the engine and operate the controls to activate the air conditioner.

## AUTOMATIC OPERATION

### Cooling and/or dehumidified heating (AUTO)

This mode may be normally used all year round as the system automatically works to keep a constant temperature. Air flow distribution and fan speed are also controlled automatically.

1. Push the “AUTO” button on. (AUTO will be displayed.)
2. Push the temperature set button to set the desired temperature.
  - Adjust the temperature to about 75°F (24°C) for normal operation.
  - The temperature of the passenger compartment will be maintained automatically. Air flow distribution and fan speed are also controlled automatically.
3. You can individually set driver and front passenger side temperature using each temperature control button. When the “DUAL” button is pushed or passenger side temperature control button is turned, the DUAL indicator will come

on. To turn off the passenger side temperature control, push the “DUAL” button.

### Heating (A/C OFF)



The air conditioner does not activate. When you need to heat only, use this mode.

1. Push the “A/C” button. (A/C OFF will be displayed and A/C indicator will turn off.)
2. Push the temperature set button to set the desired temperature.
  - The temperature of the passenger compartment will be maintained automatically. Air flow distribution and fan speed are also controlled automatically.
  - Do not set the temperature lower than the outside air temperature. Otherwise the system may not work properly.
  - Not recommended if windows fog up.

### Dehumidified defrosting or defogging

1. Push the “ FRONT defroster button on. (The indicator light on the button will come on.)

2. Push the temperature set button to set the desired temperature.

- To quickly remove ice from the outside of the windows, push the fan speed control button “+” and set to the maximum position.
- As soon as possible after the windshield is clean, push the “AUTO” button to return to the auto mode.
- When the “” front defroster button is pushed, the air conditioner will automatically be turned on at outside temperatures above 23°F (-5°C) to defog the windshield, and the air recirculate mode will automatically be turned off.

Outside air is drawn into the passenger compartment to improve the defogging performance.



## MANUAL OPERATION



### Fan speed control

Push the fan control button “” to manually control the fan speed.



Push the “AUTO” button to return to automatic control of the fan speed.

### Air recirculation



Push the intake air control button “ ” to recirculate interior air inside the vehicle. The indicator light on the “” side will come on.

The  air recirculation mode cannot be activated when the air conditioner is in the front defrosting mode “”.

### Fresh air





Push the button “ ” to draw outside air into the passenger compartment. The indicator light on the “” side will come on.

### Automatic intake air control

In the AUTO mode, the intake air will be controlled automatically. To manually control the intake air, push the intake air control “ ”. To return to the automatic control mode, push the intake air control button for about 2 seconds. The indicator lights (both air recirculate and fresh air buttons) will flash twice, and then the intake air will be controlled automatically.

### Air flow control

Pushing the “MODE” manual air flow control button selects the air outlet to:

- : Air flows from center and side ventilators.
- : Air flows from center and side ventilators and foot outlets.
- : Air flows mainly from foot outlets.
- : Air flows from defroster and foot outlets.

### To turn the system off

Push the “OFF” button.

### OPERATING TIPS

When the engine coolant temperature and outside air temperature are low, the air flow from the foot outlets may not operate for a maximum of 150 seconds. However, this is not a malfunction. After the coolant temperature warms up, the air flow from the foot outlets will operate normally.

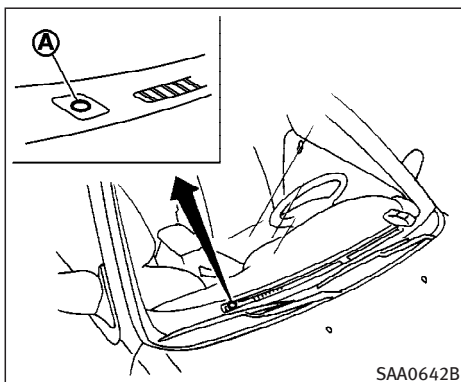

The filter should be replaced if the air flow decreases significantly or if windows fog up easily when operating the heater or air conditioning system.

The sensor **A** on the instrument panel helps maintain a constant temperature; do not put anything on or around this sensor.

### IN-CABIN MICROFILTER (if so equipped)

The air conditioning system is equipped with an in-cabin microfilter which collects dirt, pollen, dust, etc. To make sure the air conditioner heats, defogs, and ventilates efficiently, replace the filter in accordance with the maintenance schedule in the “INFINITI Service and Maintenance Guide”. To replace the filter, contact an INFINITI dealer.

## 4-24 Display screen, heater, air conditioner and audio systems

## SERVICING AIR CONDITIONER

The air conditioning system in your INFINITI vehicle is charged with a refrigerant designed with the environment in mind. **This refrigerant will not harm the earth’s ozone layer.** However, special charging equipment and lubricants are required when servicing your INFINITI air conditioner. Using improper refrigerants or lubricants will cause severe damage to your air conditioning system. See “Capacities and recommended fuel/lubricants” in the “9. Technical and consumer information” section for air conditioning system refrigerant and lubricant recommendations.

An INFINITI dealer will be able to service your environmentally friendly air conditioning system.



### WARNING

The air conditioner system contains refrigerant under high pressure. To avoid personal injury, any air conditioner service should be done only by an experienced technician with proper equipment.



## AUDIO SYSTEM

Turn the ignition key to ACC or ON and press the power on switch to turn on the radio. If you listen to the radio with the engine not running, the key should be turned to the ACC position.

Radio reception is affected by station signal strength, distance from radio transmitter, buildings, bridges, mountains and other external influences. Intermittent changes in reception quality normally are caused by these external influences.

**Using a cellular phone in or near the vehicle may influence radio reception quality.**

### Radio reception

Your radio system is equipped with state-of-the-art electronic circuits to enhance radio reception. These circuits are designed to extend reception range, and to enhance the quality of that reception.

However there are some general characteristics of FM, AM and satellite radio signals that can affect radio reception quality in a moving vehicle, even when the finest equipment is used. These characteristics are completely normal in a given reception area, and do not indicate any malfunction in your radio system.

Remember that a moving vehicle is not the ideal place to listen to a radio. Because of the movement, reception conditions will constantly change. Buildings, terrain, signal distance and interference from other vehicles can work against ideal reception. Described below are some of the factors that can affect your radio reception.



### FM RADIO RECEPTION

**Range:** FM range is normally limited to 25 to 30 miles (40 to 48 km), with monaural (single channel) FM having slightly more range than stereo FM. External influences may sometimes interfere with FM station reception even if the FM station is within 25 miles (40 km). The strength of the FM signal is directly related to the distance between the transmitter and receiver. FM signals follow a line-of-sight path, exhibiting many of the same characteristics as light. For example they will reflect off objects.

**Fade and drift:** As your vehicle moves away from a station transmitter, the signals will tend to fade and/or drift.

**Static and flutter:** During signal interference from buildings, large hills or due to antenna position, usually in conjunction with increased distance from the station transmitter, static or flutter can be heard. This can be reduced by adjusting the treble control counterclockwise to reduce treble response.

**Multipath reception:** Because of the reflective characteristics of FM signals, direct and reflected signals reach the receiver at the same time. The signals may cancel each other, resulting in momentary flutter or loss of sound.

## **AM RADIO RECEPTION**

AM signals, because of their low frequency, can bend around objects and skip along the ground. In addition, the signals can be bounced off the ionosphere and bent back to earth. Because of these characteristics, AM signals are also subject to interference as they travel from transmitter to receiver.

**Fading:** Occurs while the vehicle is passing through freeway underpasses or in areas with many tall buildings. It can also occur for several seconds during ionospheric turbulence even in areas where no obstacles exist.

**Static:** Caused by thunderstorms, electrical power lines, electric signs and even traffic lights.

## **SATELLITE RADIO RECEPTION (if so equipped)**

When the satellite radio is first installed or the battery has been replaced, the satellite radio may not work properly. This is not a malfunction. Wait more than 10 minutes with satellite radio ON for satellite radio to receive all of the necessary data.

No satellite radio reception is available unless optional satellite receiver and antenna are installed and an XM<sup>®</sup> or SIRIUS<sup>™</sup> satellite radio service subscription is active.

Satellite radio is not available in Alaska and Hawaii.

Satellite radio performance may be affected if cargo carried on the roof blocks the satellite radio signal.

Do not put cargo over the satellite antenna.

## AUDIO OPERATION PRECAUTIONS

### Compact Disc (CD) player

- During cold weather or rainy days, the player may malfunction due to the humidity. If this occurs, remove the CD and dehumidify or ventilate the player completely.
- The player may skip while driving on rough roads.
- The CD player sometimes cannot function when the passenger compartment temperature is extremely high. Decrease the temperature before use.

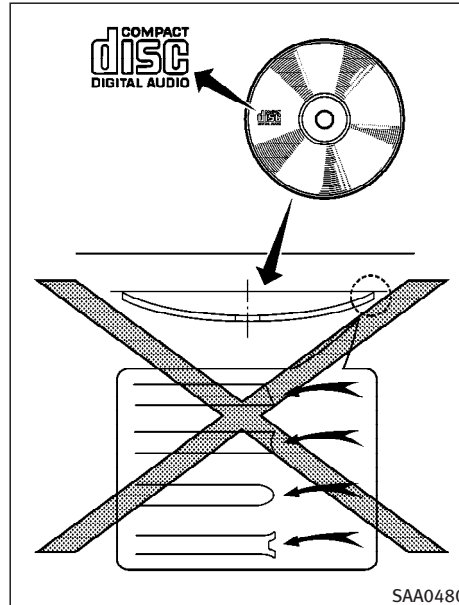

- Only use high quality 4.7 inches (12 cm) round discs that have the “COMPACT disc DIGITAL AUDIO” logo on the disc or packaging.

- Do not expose the CD to direct sunlight.
- CDs that are of poor quality, dirty, scratched, covered with fingerprints, or that have pin holes may not work properly.
- The following CDs may not work properly:
  - Copy control compact discs (CCCD)
  - Recordable compact discs (CD-R)
  - Rewritable compact discs (CD-RW)
- Do not use the following CDs as they may cause the CD player to malfunction.
  - 3.1 in (8 cm) discs
  - CDs that are not round
  - CDs with a paper label
  - CDs that are warped, scratched, or have abnormal edges
- CDs with MP3 or WMA format cannot be written in this audio system.
- If the CD cannot be played, one of the following messages will be displayed.

#### CHECK DISC:

- Confirm that the CD is inserted correctly (the label side is facing up, etc.).
- Confirm that the CD is not bent or warped and it is free of scratches.

#### PUSH EJECT:

This is a malfunction due to excessive temperature inside the player. Remove the CD by pushing the “EJECT” button. After a short time, reinsert the CD. The CD can be played when the temperature of the player returns to normal.

#### UNPLAYABLE:

The file is unplayable in this audio system (only MP3 or WMA CD).

### Compact Disc (CD) with MP3 or WMA

#### Explanation of terms:

- MP3 — MP3 is short for Moving Pictures Experts Group Audio Layer 3. MP3 is the most well-known compressed digital audio file format. This format allows for near “CD quality” sound, but at a fraction of the size of normal audio files. MP3 conversion of an audio track from CD-ROM can reduce the file size by approximately 10:1 ratio with virtually no perceptible loss in quality. MP3 compression removes the redundant and irrelevant parts of a sound signal that the human ear doesn’t hear.
- WMA — Windows Media Audio (WMA) is a compressed audio format created by Microsoft as an alternative to MP3. The WMA codec offers greater file compression than the MP3 codec, enabling storage of more digital audio tracks in the same amount of space when compared to MP3s at the same level of quality.
- Bit rate — Bit rate denotes the number of bits per second used by a digital music file. The size and quality of a compressed digital audio file is determined

by the bit rate used when encoding the file.

- Sampling frequency — Sampling frequency is the rate at which the samples of a signal are converted from analog to digital (A/D conversion) per second.
- Multisession — Multisession is one of the methods for writing data to media. Writing data once to the media is called a single session, and writing more than once is called a multisession.
- ID3/WMA Tag — The ID3 tag is the part of the encoded MP3 or WMA file that contains information about the digital music file such as song title, artist, album title, encoding bit rate, track time duration, etc. ID3 tag information is displayed on the Album/Artist/Track title line on the display.
- \* Windows<sup>®</sup> and Windows Media<sup>®</sup> are either registered trademarks or trademarks of Microsoft Corporation in the United States and/or other countries.

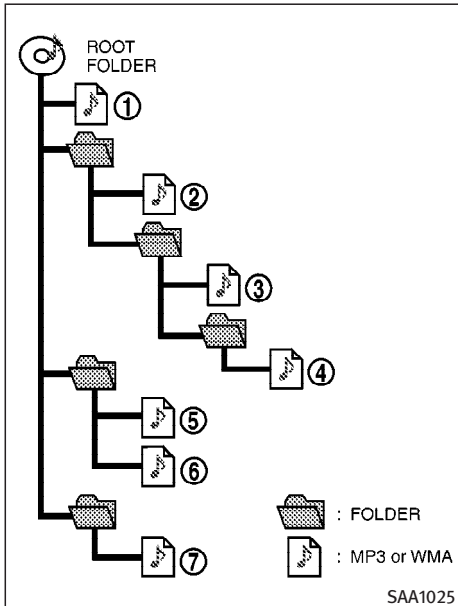

- The names of folders not containing MP3/WMA files are not shown in the display.
- If there is a file in the top level of the disc, “ROOT” is displayed.
- The playback order is the order in which the files were written by the writing software. Therefore, the files might not play in the desired order.

#### Playback order:

Playback order of the CD with compressed files (MP3/WMA) is as illustrated above.

**Specification chart:**

Supported media		CD, CD-R, CD-RW	
Supported file systems		ISO9660 LEVEL1, ISO9660 LEVEL2, Romeo, Joliet * ISO9660 Level 3 (packet writing) is not supported.	
Supported versions*	MP3	Version	MPEG1, MPEG2, MPEG2.5
		Sampling frequency	8 kHz - 48 kHz
		Bit rate	8 kbps - 320 kbps, VBR
	WMA	Version	WMA7, WMA8, WMA9
		Sampling frequency	32 kHz - 48 kHz
		Bit rate	48 kbps - 192 kbps, VBR
Tag information		ID3 tag VER1.0, VER1.1, VER2.2, VER2.3 (MP3 only)	
Folder levels		Folder levels: 8, Folders: 255 (including root folder), Files: 512	
Text character number limitation		128 characters	
Displayable character codes		01: ASCII, 02: ISO-8859-1, 03: UNICODE (UTF-16 BOM Big Endian), 04: UNICODE (UTF-16 Non-BOM Big Endian), 05: (UTF-8), 06: UNICODE (Non-UTF-16 BOM Little Endian)	

\* Files created with a combination of 48 kHz sampling frequency and 64 kbps bit rate cannot be played.

## Troubleshooting guide:

Symptom	Cause and Countermeasure
Cannot play	Check if the disc was inserted correctly.
	Check if the disc is scratched or dirty.
	Check if there is condensation inside the player. If there is, wait until the condensation is gone (about 1 hour) before using the player.
	If there is a temperature increase error, the CD player will play correctly after it returns to the normal temperature.
	If there is a mixture of music CD files (CD-DA data) and MP3/WMA files on a CD, only the music CD files (CD-DA data) will be played.
	Files with extensions other than “.MP3”, “.WMA”, “.mp3” or “.wma” cannot be played. In addition, the character codes and number of characters for folder names and file names should be in compliance with the specifications.
Poor sound quality	Check if the disc is scratched or dirty.
	The bit rate may be too low.
It takes a relatively long time before the music starts playing.	If there are many folder or file levels on the MP3/WMA disc, or if it is a multisession disc, some time may be required before the music starts playing.
Music cuts off or skips	The writing software and hardware combination might not match, or the writing speed, writing depth, writing width, etc., might not match the specifications. Try using the slowest writing speed.
Skipping with high bit rate files	Skipping may occur with large quantities of data, such as for high bit rate data.
Move immediately to the next song when playing.	When a non-MP3/WMA file has been given an extension of “.MP3”, “.WMA”, “.mp3” or “.wma”, or when play is prohibited by copy-right protection, there will be approximately 5 seconds of no sound and then the player will skip to the next song.
The songs do not play back in the desired order.	The playback order is the order in which the files were written by the writing software. Therefore, the files might not play in the desired order.

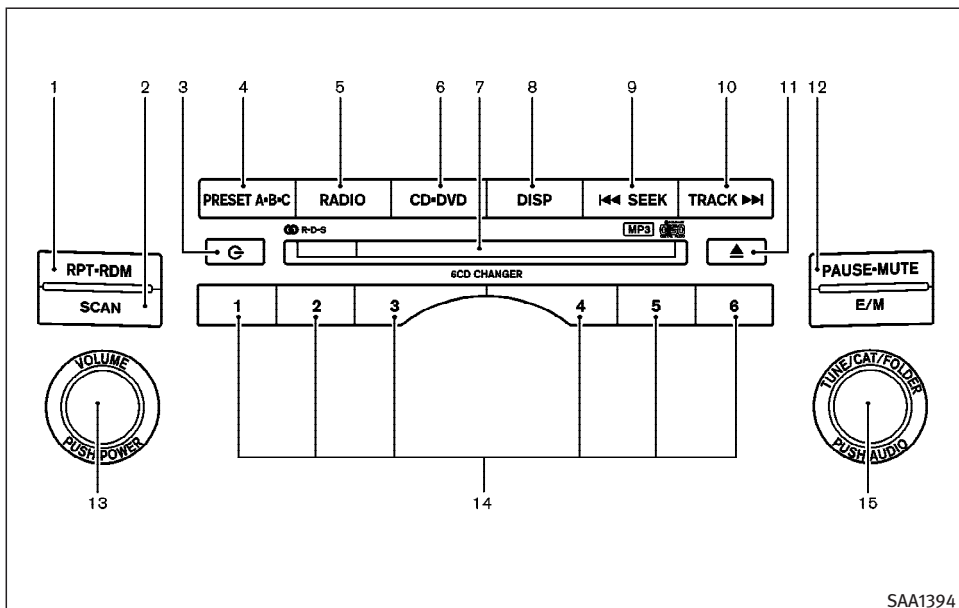

#### Without Navigation system

- |                                       |   |
|---------------------------------------|---|
| 1. “RPT (Repeat)·RDM (Random)” button | 5. “RADIO” FM-AM-SAT band select button |
| 2. “SCAN” button                      | 6. “CD-DVD” play button                 |
| 3. “CD LOAD” button                   | 7. CD slot                              |
| 4. “A.B.C.” preset select button      | 8. “DISP (Display)” button              |

9. “SEEK/APS REW” button
10. “APS FF/TRACK CHANGE” button
11. “CD EJECT” button
12. “PAUSE/MUTE” button
13. POWER ON-OFF/VOLUME control knob
14. Station and preset (FM/AM/SAT)/CD insert/eject or CD play select button
15. TUNE knob, FOLDER select and AUDIO (BASS, TREBLE, FADE, and BALANCE, SSV and NR (Dolby)) knob

\*: No satellite radio reception is available unless optional satellite receiver and antenna are installed and an XM<sup>®</sup> or SIRIUS<sup>™</sup> satellite radio service subscription is active.



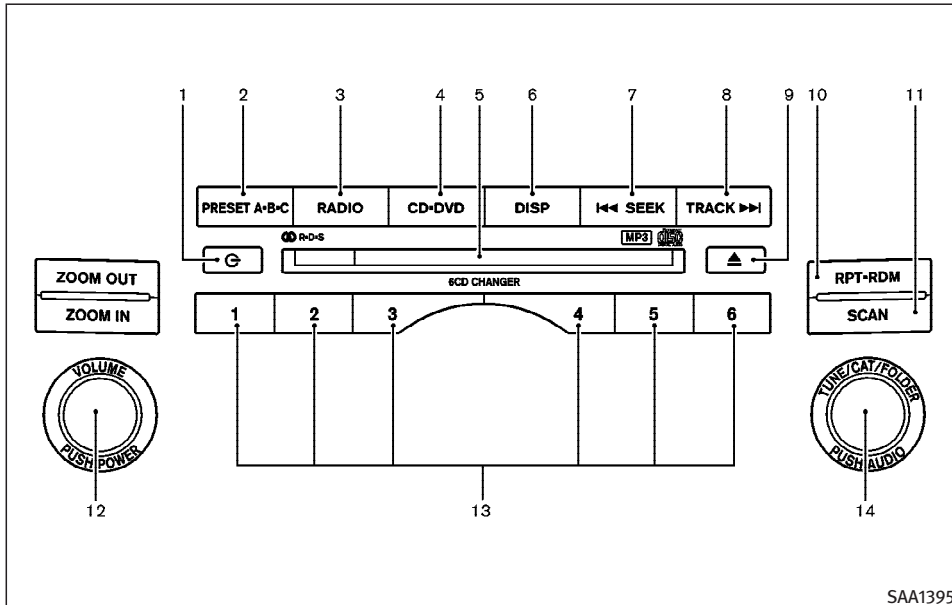

#### With Navigation system

- |   |                                 |
|---|---------------------------------|
| 1. “CD LOAD” button                     | 5. CD slot                      |
| 2. “A.B.C.” preset select button        | 6. “DISP (Display)” button      |
| 3. “RADIO” FM-AM-SAT band select button | 7. “SEEK/APS REW” button        |
| 4. “CD/DVD” play button                 | 8. “APS FF/TRACK CHANGE” button |

9. “CD EJECT” button
10. “RPT (Repeat) RDM (Random)” play button
11. “SCAN” button
12. “POWER ON-OFF/VOLUME” control knob
13. Station and preset (FM/AM/SAT)/CD insert/eject or CD play select button
14. TUNE knob, FOLDER select and AUDIO (BASS, TREBLE, FADE, and BALANCE, SSV and NR (Dolby)) knob

\*: No satellite radio reception is available unless optional satellite receiver and antenna are installed and an XM® or SIRIUS™ satellite radio service subscription is active.

It may take some time to receive the activation signal after subscribing to the XM<sup>®</sup> or SIRIUS<sup>™</sup> satellite radio provider. After receiving the activation signal, an available channel list will be automatically updated in the radio. For XM<sup>®</sup>, turn the ignition switch from the LOCK to ACC position to update the channel list.

Satellite radio is not available in Alaska and Hawaii.

## FM-AM-SATELLITE RADIO WITH COMPACT DISC (CD) CHANGER

### Audio main operation

#### Head unit:

The radio has an FM diversity reception system, which employs an antenna printed on the rear window. This system automatically switches to the antenna which is receiving less interference.

The auto loudness circuit enhances the low frequency range automatically in both radio reception and CD playback.

#### POWER on/off:

Turn the ignition switch to the ACC or ON position, and then push the “POWER” on/off button while the system is off to call

up the mode (radio, CD or DVD) which was playing immediately before the system was turned off. When no CD or DVD is loaded, the radio will come on. While the system is on, pushing the “POWER” on/off button turns the system off.

#### Volume control:

Turn the volume control knob to adjust the volume.

This vehicle has **Speed Sensitive control Volume (SSV) for audio**. The audio volume changes as the driving speed changes.

#### AUDIO knob (BASS, TREBLE, FADER, BALANCE, SSV):

Push the AUDIO knob to change the select-ing mode as follows.

BASS → TREBLE → FADE → BALANCE → SSV → (Normal) → BASS

To adjust Bass, Treble, Fader and Balance, push the AUDIO knob until the desired mode BASS, TREBLE, FADE or BALANCE appears in the display. Turn the AUDIO knob to adjust Bass, Treble, Fade or Balance. Fade adjusts the sound level between the front and rear speakers and Balance ad-justs the sound between the right and left speakers.

To change the SSV mode to OFF, LOW, MID or HIGH, turn the AUDIO knob.

After 10 seconds, the radio, or CD display reappears. Once the sound quality is set to the desired level, push the AUDIO knob repeatedly until the radio, or CD display ap-pears.

#### **DISP** DISPLAY CHANGE:

This button will work during FM radio, sat-ellite radio (if so equipped) and CD opera-tion. Find the detailed function in the de-scription of each item.

#### **PAUSE MUTE** Pause/mute button (if so equipped):

To mute or pause the audio sound, push the “PAUSE/MUTE” button.

To release the mute or pause, push the button again.

### FM-AM-SAT radio operation

#### **RADIO** RADIO (FM/AM/SAT) band select:

Pushing the **RADIO** band select button will change the band as follows:

(Without satellite radio)

AM → FM → AM

(With satellite radio)

AM → FM → SAT (XM/SR) → AM

No satellite radio reception is available unless optional satellite receiver and antenna are installed and an XM® or SIRIUS™ satellite radio service subscription is active.

Satellite radio is not available in Alaska and Hawaii.

When the RADIO band select button is pushed while the ignition switch is in the ACC or ON position, the radio will come on at the station last played.

The last station/channel played will also come on when the ON-OFF/VOL control knob is pushed to ON.

If another audio source is playing when the “RADIO” button is turned to ON, the other audio source will automatically be turned off and the last radio station played will come on.

The FM stereo indicator ST will glow during FM stereo reception. When the stereo broadcast signal is weak, the radio will automatically change from stereo to monaural reception.

### TUNE (Tuning):



### WARNING

The radio should not be tuned while driving so full attention may be given to vehicle operation.

- For AM and FM radio  
Turn the TUNE/FOLDER knob for manual tuning.
- For satellite radio  
Turn the TUNE/FOLDER knob to seek channels from all of the categories when any CAT is not selected.



### SEEK tuning:

- For AM and FM radio  
Push the “SEEK/TRACK” button ◀◀ or ▶▶ for less than 1.5 seconds to tune from high to low or low to high frequencies and to stop at each broadcasting station for 5 seconds. Pushing the button again during this 5 second period will stop SEEK tuning and the radio will remain turned to that station. Push the “SEEK/TRACK” button ◀◀ or ▶▶ for more than 1.5 seconds to tune

from high to low or low to high frequencies and to stop at each broadcasting station for 5 seconds. Pushing the button again during this 5 second period will stop SEEK tuning and the radio will remain turned to that station.

- For satellite radio  
After selecting a CAT name, push the “SEEK/TRACK” button ◀◀ or ▶▶ to seek the next or previous channel in the selected category. To seek the first channels listed in each category, push the “SEEK/TRACK” button ◀◀ or ▶▶ before selecting a CAT name.

To cancel the CAT mode, push the **BACK** “↶” button on the INFINITI controller.

### SCAN SCAN tuning:

Push the SCAN tuning button to tune from low to high frequencies and stops at each broadcasting station for 5 seconds. Pushing the button again during this 5 seconds period will stop “SCAN” tuning and the radio will remain tuned to that station.

If the “SCAN” tuning button is not pushed within 5 seconds, SCAN tuning moves to the next station.

**PRESET  
A·B·C** **PRESET select:**

Push the “PRESET” select button to go to the next PRESET. After choosing from the PRESET A, B or C, you can select the desired channel using the INFINITI controller or pushing the station preset buttons

**1** to **6**.

**1** to **6** **Station memory operations:**

Six stations/channels can be set for PRESET A, B and C. The PRESET A, B and C function allows you to store a combination of FM, AM and SAT (if so equipped) stations for easy access.

1. Choose preset channel A, B or C using the preset select button.
2. Tune to the desired station using the “SEEK”, “SCAN” or “TUNE” button.
3. Select the desired station/channel and keep pushing any of the desired station preset buttons **1** to **6** until a beep sound is heard. (The radio mutes when the select button is pushed.)
4. The channel indicator will then come on and the sound will resume. Memorizing is now complete.

#### 4-36 Display screen, heater, air conditioner and audio systems

5. Other buttons can be set in the same manner.

If the battery cable is disconnected, or if the fuse blows, the radio memory will be erased. In that case, reset the desired stations.

**DISP** **DISPLAY:**

- By pushing the “DISP” button for more than 1.5 seconds while receiving FM radio waves, “PS NAME” switches between ON and OFF.

- Pushing the “DISP” button will display additional information about the satellite radio broadcast (for example: Artist name, Title).

Keep pushing the “DISP” button, and it will change the information of the satellite radio broadcast to be displayed as follows:

CH Number → CH Name → Artist Name  
→ Song Title → CH Number

**Station memory operations:**

Six stations/channels can be set for the FM band, six for satellite radio (if so equipped) and six stations can be set for the AM band.

1. Tune to the desired station using the “SEEK”, “SCAN” or “TUNE” button.

2. Select the desired station/channel and keep pushing any of the desired station preset buttons (1 to 6) until a beep sound is heard. (The radio mutes when the select button is pushed.)

3. The channel indicator will then come on and the sound will resume. Memorizing is now complete.

4. Other buttons can be set in the same manner.

If the battery cable is disconnected, or if the fuse blows, the preset station memory will be erased. In that case, reset the desired stations.

**CATEGORY (CAT):**

**1. CAT selection mode**

CAT name selection can be done by turning the TUNE/FOLDER knob in the CAT selection mode or by using the INFINITI controller when the CAT list is displayed on the screen.

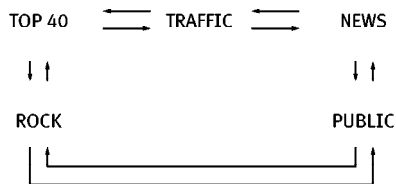

## 2. CAT SEEK tuning mode

After selecting a CAT name, push the “SEEK/TRACK” button **◀◀** or **▶▶** to seek the next or previous channel in the selected category.

To seek the first channels listed in each category, push the “SEEK/TRACK” button **◀◀** or **▶▶** before entering the CAT select mode.

To cancel the CAT mode, push the **BACK** “**↶**” button on the INFINITI controller.

## 3. CAT SCAN tuning mode

After selecting a CAT name, push the “SEEK/TRACK” button for more than 1.5 seconds to scan channels in the selected category, and stop at each channel for 5 seconds. Pushing the button again during this 5 second period will stop SCAN tuning and the radio will remain tuned to that station.

To scan the first channels listed in each category, push the “SEEK/TRACK” button **◀◀** or **▶▶** for more than 1.5 seconds before entering the CAT select mode.

## 4. Information screen

The following notices will be displayed under certain conditions.

- NO SIGNAL (No signal is received while the SAT tuner is connected.)
- OFF AIR (Broadcasting signed off)
- ANTENNA ERROR (Antenna connection error)
- LOADING(XM)/ACQUIRING(SR) (When the initial setting is performed)
- UPDATING(XM)/CALL XXXX(SR) (When the satellite radio subscription is not active)
- INVALID CH (Invalid channel is received.)

## Compact disc (CD) changer operation

Turn the ignition switch to the ACC or ON position and insert the compact disc into the slot with the label side facing up. The compact disc will be guided automatically

into the slot and start playing. To insert the disc, first push the “LOAD” button.

After loading the disc, the number of tracks on the disc and the play time will appear on the display.

If the radio or tape is already operating, it will automatically turn off and the compact disc will play.



## CAUTION

**Do not force the compact disc into the slot. This could damage the player.**

If the system has been turned off while the compact disc was playing, pushing the ON-OFF/VOL control knob will start the compact disc.



## CD LOAD button:

To insert a CD in the CD changer, push the “**⊞**” button for less than 1.5 seconds. Select the loading slot by pushing the CD insert select button (1 to 6), then insert the CD.

To insert 6 CDs to the CD changer, push the “**⊞**” button for more than 1.5 seconds.

The inserted slot numbers will illuminate on the display.

#### **CD-DVD** CD PLAY:

When the “CD-DVD” button is pushed with the system off and the CD loaded in the CD changer, the CD changer or the rear INFINITI mobile entertainment system (if so equipped) will start to play.

Pushing the “CD-DVD” button changes operations alternately as follows:

CD → DVD → CD

When the “CD-DVD” button is pushed with the CD loaded with another audio source playing, the other source will automatically be turned off and

- the CD will start to play if the last play was a CD.
- the DVD will start to play if the last play was a DVD.

#### **DISP** DISPLAY:

When the display button is pushed for more than 1.5 seconds while the CD is being played, the music information displayed can be changed in the following order.

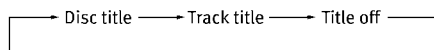

CD:



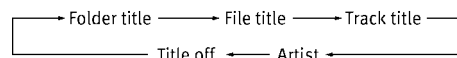

CD with MP3 or WMA:



**FF (Fast Forward), REW (Rewind)/APS (Automatic Program Search) FF, APS REW:**

When the “ ” (rewind) or “ ” (fast forward) button is pushed for more than 1.5 seconds while the compact disc is being played, the compact disc will play while fast forwarding or rewinding. When the button is released, the compact disc will return to normal play speed.

When the “ ” or “ ” button is pushed for less than 1.5 seconds while the compact disc is being played, the next track or the beginning of the current track on the CD will be played.

The INFINITI controller can also be used to select tracks when a CD is being played.

**CD PLAY selection:**

To change to another CD already loaded into the player, push the CD play select buttons **1** to **6** or choose a disc displayed on the screen using the INFINITI controller.

#### **SCAN** SCAN tuning:

When the “SCAN” tuning button is pushed for less than 1.5 seconds while the CD is being played, the beginning of all the CD programs in each track will be played for 10 seconds in sequence.

When the “SCAN” tuning button is pushed for more than 1.5 seconds while the CD is being played, the first program in all the CDs will be played for 10 seconds.

Pushing the button again during this 10 second period will stop SCAN tuning.

If the “SCAN” tuning button is not pushed within 10 seconds, SCAN tuning moves to the next disc program.

#### **RPT-RDM** REPEAT (RPT)-RANDOM (RDM):

When the “RPT-RDM” play button is pushed while the compact disc is played, the play pattern can be changed as follows:

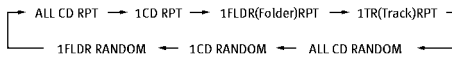
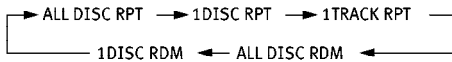

 **CD EJECT:**

When the “CD EJECT” button is pushed with the compact disc loaded, the compact disc will be ejected.

To eject the discs selected by the “EJECT” button, push it for less than 1.5 seconds.

To eject all the discs, push the “EJECT” button for more than 1.5 seconds.

**If the compact disc comes out and is not removed, it will be pulled back into the slot to protect it.**

**DVD OFF function:**

It is possible to turn off the INFINITI Mobile Entertainment System (MES) from the front seat. When the ON-OFF switch is pushed when the DVD is being played from the speakers (with DVD displayed), the MES is turned off. (The audio system will not turn off. If a CD is loaded, the CD will be played.) Pushing the “CD-DVD” button with

no DVD discs loaded will turn on the MES (mute).

The sound resumes when a DVD disc is loaded or another audio source is connected to the auxiliary input jacks.

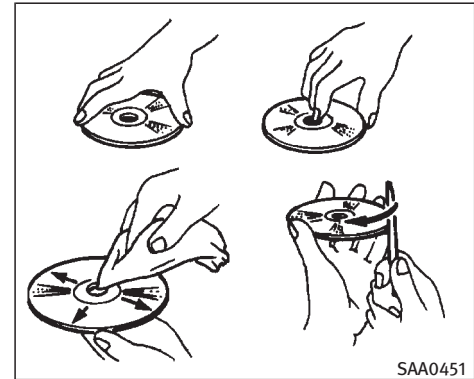

**CD CARE AND CLEANING**

- Handle a CD by its edges. Never touch the surface of the disc. Do not bend the disc.
- Always place the discs in the storage case when they are not being used.
- To clean a disc, wipe the surface from the center to the outer edge using a clean, soft cloth. Do not wipe the disc using a circular motion. Do not use a conventional record cleaner or alcohol intended for industrial use.

- A new disc may be rough on its inner and outer edges. Remove the rough edges using the side of a pen or pencil as illustrated.

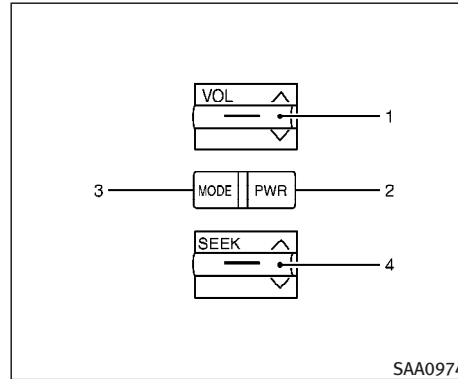

**Type A**

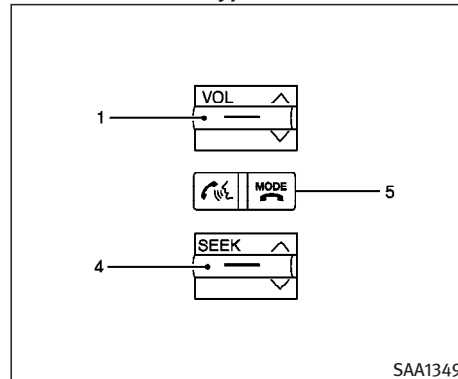

**Type B**

1. VOLUME control switch
2. POWER on/off switch
3. MODE select switch
4. Tuning switch
5. POWER on/MODE select switch

### STEERING WHEEL SWITCH FOR AUDIO CONTROL (if so equipped)

The audio system can be operated using the controls on the steering wheel.

#### POWER on/off switch

With the ignition switch turned to the ACC or ON position, push the POWER switch to turn the audio system on or off.

#### MODE select switch

Push the MODE select switch to change the mode in the sequence of AM, FM, SAT (if so equipped) and CD.

Pushing this switch also turns the audio system on when it is off.

#### POWER on/MODE select switch (if so equipped)

With the ignition switch turned to the ACC or ON position, push the POWER on/MODE select switch to turn the audio system on.



Push the switch to change the mode in the sequence of AM, FM, SAT and CD.



### VOLUME control switch

Push up/down the VOLUME control switch to increase or decrease the volume.





Tuning switch



### Memory change (radio):

Push up/down the tuning switch  or  for less than 1.5 seconds to change the radio frequency.

### SEEK tuning (radio):

Push up/down the tuning switch  or  for more than 1.5 seconds to seek the next or previous radio station.



### APS (Automatic Program Search) FF, APS REW (CD):



Push up/down the tuning switch  or  for less than 1.5 seconds to return to the beginning of the present program or skip to the next program. Push several times to skip back or skip through programs.

This system searches for the blank intervals between selections. If there is a blank interval within one program or there is no



interval between programs, the system may not stop in the desired or expected location.

### FOLDER change (CD with MP3/WMA):

Push up/down the tuning switch  or  for more than 1.5 seconds to change the folders (if it has folders).

Push up/down the tuning switch  or  for less than 1.5 seconds to return to the beginning of the present program or skip to the next program.

### DISC change (CD without MP3/WMA):

Push up/down the tuning switch  or  for more than 1.5 seconds to change the playing disc up or down.

## BLUETOOTH® HANDS-FREE PHONE SYSTEM WITH INFINITI VOICE RECOGNITION (if so equipped)



### WARNING

- Use a phone after stopping your vehicle in a safe location. If you have to use a phone while driving, exercise extreme caution at all times so full attention may be given to vehicle operation.
- If a conversation in a moving vehicle requires you to take notes, pull off the road to a safe location and stop your vehicle before doing so.



### CAUTION

To avoid draining the vehicle battery, use a phone after starting the engine.

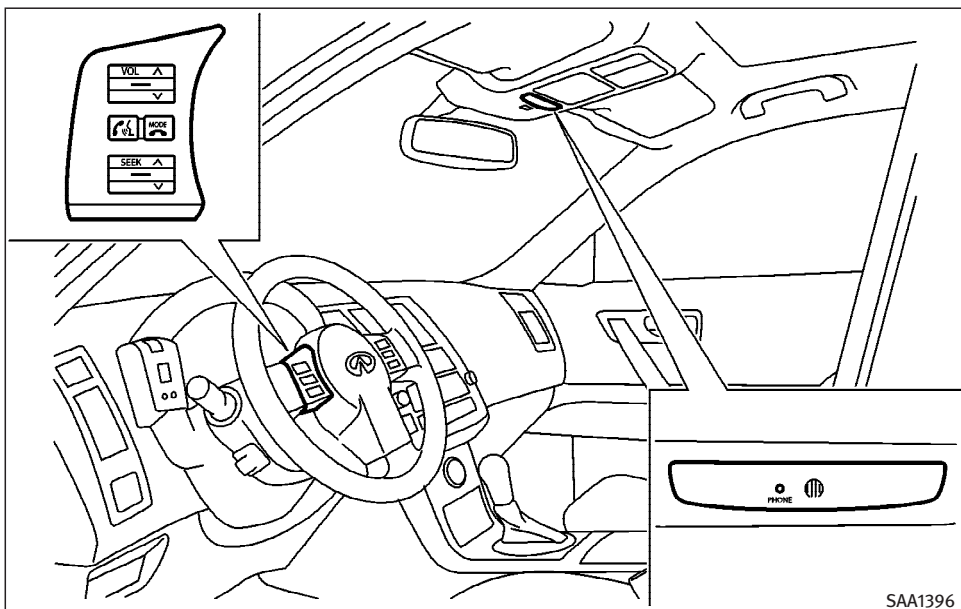

Your INFINITI is equipped with the Bluetooth® Hands-Free Phone System. If you are an owner of a Bluetooth® enabled cellular phone, you can set up the wireless connection between your cellular phone and the in-vehicle phone module. With

Bluetooth® wireless technology, you can make or receive a hands-free telephone call with your cellular phone in the vehicle.

Once your cellular phone is paired to the in-vehicle phone module, no other phone connecting procedure is required. Your

phone is automatically connected with the in-vehicle phone module when the ignition switch is turned to the ON position with the paired cellular phone turned on and carried in the vehicle.

You can register up to 5 different Bluetooth® cellular phones to the in-vehicle phone module. However, you can talk on only one cellular phone at a time.

Before using the Bluetooth® Hands-Free Phone System, refer to the following notes.

- Set up the wireless connection between a cellular phone and the in-vehicle phone module before using the Bluetooth® Hands-Free Phone System.
- Some Bluetooth® enabled cellular phones may not be recognized by the in-vehicle phone module. Please visit [www.infiniti.com/bluetooth](http://www.infiniti.com/bluetooth) for a recommended phone list.
- You will not be able to use a hands-free phone under the following conditions:
  - Your vehicle is outside of the telephone service area.

- Your vehicle is in an area where it is difficult to receive radio waves; such as in a tunnel, in an underground parking garage, near a tall building or in a mountainous area.
- Your cellular phone is locked to prevent it from being dialed.

When the radio wave condition is not ideal or ambient sound is too loud, it may be difficult to hear the other person's voice during a call.

Do not place the cellular phone in an area surrounded by metal or far away from the in-vehicle phone module to prevent tone quality degradation and wireless connection disruption.

While a cellular phone is connected through the Bluetooth<sup>®</sup> wireless connection, the battery power of the cellular phone may discharge quicker than usual.

If the Bluetooth<sup>®</sup> Hands-Free Phone System seems to be malfunctioning, please refer to “Troubleshooting guide” later in this section. You can also visit [www.infiniti.com/bluetooth](http://www.infiniti.com/bluetooth) for troubleshooting help.

Refer to the cellular phone Owner's Manual regarding the telephone charges, cellular phone antenna and body, etc.

**This device complies with Part 15 of the FCC Rules. Operation is subject to the following two conditions: (1) this device may not cause harmful interference, and (2) this device must accept any interference received, including interference that may cause undesired operation.**

FCC Radiation Exposure Statement:

This equipment complies with FCC radiation exposure limits set forth for an uncontrolled environment. This equipment should be installed and operated with minimum distance 8 inch (20 cm) between the radiator and your body. This Transmitter must not be co-located or operating in conjunction with any other antenna or transmitter.

## USING THE SYSTEM

The INFINITI Voice Recognition system allows hands-free operation of the Bluetooth<sup>®</sup> Hands-Free Phone System.

If the vehicle is in motion, some commands may not be available so full attention may be given to vehicle operation.

## Initialization

When the ignition switch is turned to the ON position, INFINITI Voice Recognition is initialized, which takes a few seconds. When completed, the amber light on the overhead console illuminates and the system is ready to accept voice commands. If the “” button is pushed before the initialization completes, the system will announce “Hands-free phone system not ready” and will not react to voice commands.

## Operating tips

To get the best performance out of the INFINITI Voice Recognition system, observe the following:

- Keep the interior of the vehicle as quiet as possible. Close the windows to eliminate surrounding noises (traffic noises, vibration sounds, etc.), which may prevent the system from recognizing voice commands correctly.
- Wait until the tone sounds before speaking a command. Otherwise, the command will not be received properly.

- Start speaking a command within 5 seconds after the tone sounds.
- Speak in a natural voice without pausing between words.

### Giving voice commands

To operate INFINITI Voice Recognition, push and release the “” button located on the steering wheel. The light on the overhead console flashes to signal you have entered a voice recognition (VR) session. After the tone sounds, speak a command.

The command given is picked up by the microphone, and voice feedback is given when the command is accepted.

- If you need to hear the available commands for the current menu again, say “Help” and the system will repeat them.
- If a command is not recognized, the system announces, “Command not recognized. Please try again.” Repeat the command in a clear voice.
- If you want to go back to the previous command, you can say “Go back” or “Correction” anytime the system is waiting for a response.

- You can cancel a command when the system is waiting for a response by saying, “Cancel” or “Quit.” The system announces “Cancel” and ends the VR session. You can also push the “” button on the steering wheel at any time. Whenever the VR session is cancelled, a double beep is played to indicate you have exited the system.
- If you want to adjust the volume of the voice feedback, push the volume control switches (+ or –) on the steering wheel while being provided with feedback. You can also use the radio volume control knob.

### How to say numbers

INFINITI Voice Recognition requires a certain way to speak numbers in voice commands. Refer to the rules and examples below.

- Either “zero” or “oh” can be used for “0”.  
Example: 1-800-662-6200  
—“One eight oh oh six six two six two oh oh”, or  
—“One eight zero zero six six two six two oh oh”

- Words can be used for the first 4 digits places only.

Example: 1-800-662-6200

- “One eight hundred six six two six two oh oh”,
- NOT “One eight hundred six six two sixty two hundred, and
- NOT “One eight oh oh six six two sixty two hundred.

- Numbers can be spoken in small groups. The system will prompt you to continue entering digits, if desired.

Example: 1-800-662-6200

- “One eight oh oh”

The system repeats the numbers and prompts you to enter more.

- “six six two”

The system repeats the numbers and prompts you to enter more.

- “six two oh oh”

- You can say “Star” for \* and “Pound” for # at anytime in any position of the phone number.

Example: 1-555-1212 \*123

—“One five five five one two one two star one two three”

**NOTE:**

**For best results, say phone numbers as single digits.**

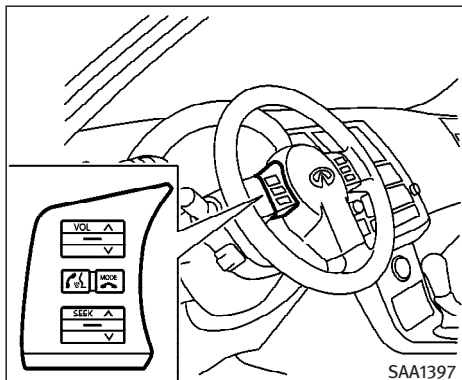

## CONTROL BUTTONS

The control buttons for the Bluetooth® Hands-Free Phone System are located on the steering wheel.

### TALK/PHONE SEND

Push the “” button to initiate a VR session or answer an incoming call.

You can also use the “” button to skip through system feedback and to enter commands during a call. See “List of voice commands” and “During a call” later in this section for more information.

### MODE/PHONE END

Push the “” button to cancel a VR session or end a call.



## GETTING STARTED

The following procedures will help you get started using the Bluetooth® Hands-Free Phone System with INFINITI Voice Recognition. For additional command options, refer to “List of voice commands” later in this section.

### Choosing a language

You can interact with the Bluetooth® Hands-Free Phone System using English, Spanish or French.

To change the language, perform the following.

1. Press and hold the “” button for more than 5 seconds.
2. The system announces: “Press the “PHONE/SEND ()” button for the hands-free phone system to enter the speaker adaptation mode or press the “PHONE/END ()” button to select a different language.”

- Press the “**MODE**” button.

For information on speaker adaptation, see “Speaker adaptation (SA) mode” later in this section.

- The system announces the current language and gives you the option to change the language to Spanish (in Spanish) or French (in French). Use the following chart to select the language.

**NOTE:**

**Note: You must press the “” button or the “**MODE**” button within 5 seconds to change the language.**

Current language	Press  (TALK/PHONE SEND) to select	Press <b>MODE</b> (MODE/PHONE END) to select
English	Spanish	French
Spanish	English	French
French	English	Spanish

- If you decide not to change the language, do not press either button. After 5 seconds, the VR session will end, and the language will not be changed.

### Pairing procedure

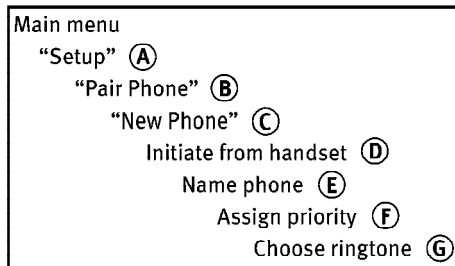

- Push the “” button on the steering wheel. The system announces the available commands.
- Say: “Setup” (A). The system acknowledges the command and announces the next set of available commands.
- Say: “Pair phone” (B). The system acknowledges the command and announces the next set of available commands.
- Say: “New phone” (C). The system acknowledges the command and asks you to initiate pairing from the phone handset (D).

When you are asked to enter a PIN code for pairing your Bluetooth® cellular

phone, operate it to enter the code “1234”.

The code is always “1234” regardless of the number of phones paired.

The pairing procedure of the cellular phone varies according to each cellular phone manufacturer. See the cellular phone Owner’s Manual for details. You can also visit [www.infiniti.com/bluetooth](http://www.infiniti.com/bluetooth) for instructions on pairing INFINITI recommended cellular phones.

- The system asks you to say a name for the phone (E).

If the name is too long or too short, the system tells you, then prompts you for a name again.

Also, if more than one phone is paired and the name sounds too much like a name already used, the system tells you, then prompts you for a name again.

- The system asks you to assign a priority level (F). The priority level determines which phone is active when more than one paired Bluetooth® phone is in the vehicle. Follow the instructions provided by the system or refer to “Setup”

later in this section for more information on changing priorities.

- The system will ask if you would like to select a custom ring tone (G). Follow the instructions provided by the system or refer to “Setup” later in this section for more information on selecting ringtones.

## Making a call by entering a phone number

Main menu

“Call” (A)

Number (speak digits) (B)

“Dial” (C)

- Push the “” button on steering wheel. A tone will sound.
- Say: “Call” (A). The system acknowledges the command and announces the next set of available commands.
- Say the number you wish to call (B). For example, 555-1212 can be said as “five five one two one two.” See “How to say numbers” earlier in this section for more information.

- When you have finished speaking the phone number, the system repeats it back and announces the available commands.
- Say: “Dial” (C). The system acknowledges the command and makes the call.

For additional command options, see “List of voice commands” later in this section.

## Receiving a call

When you hear the ring tone, press the “” button on the steering wheel.

Once the call has ended, press the “” button on the steering wheel.

### NOTE:

**If you do not wish to take the call when you hear the ring tone, press the “” button on the steering wheel to reject the call.**

For additional command options, see “List of voice commands” later in this section.

## LIST OF VOICE COMMANDS

Main menu

“Call”

“Phone Book”

“Memo Pad”

“Setup”

When you push and release the “” button on the steering wheel, you can choose from the commands on the Main Menu. The following pages describe these commands and the commands in each sub-menu.



**Remember to wait for the tone before speaking.**

You can say “Help” to hear the list of commands currently available anytime the system is waiting for a response.

If you want to end an action without completing it, you can say “Cancel” or “Quit” at anytime the system is waiting for a response. The system will end the VR session. Whenever the VR session is cancelled, a double beep is played to indicate you have exited the system.

If you want to go back to the previous command, you can say “Go back” or “Correction” anytime the system is waiting for a response.

When you get used to the menus in the system, you can talk ahead by saying more than one command at a time. For example, say, “Call five five one two one two” or “Memo pad record.”

Also, when you get used to the system responses, you can skip ahead to the tone by pressing the “” button on the steering wheel. However, if you press the “” button when the system is waiting for a response from you it will end the VR session.

“Call”

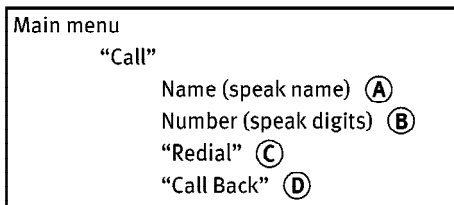

#### Name (speak name) (A)

If you have stored entries in the Phone Book, you can dial a number associated with a name and location.

See “Phone book” later in this section to learn how to store entries.

When prompted by the system, say the name of the phone book entry you wish to call. The system acknowledges the name.

If there are multiple locations associated with the name, the system asks you to choose the location.

Once you have confirmed the name and location, the system begins the call.

#### Number (speak digits) (B)

When prompted by the system, say the number you wish to call. Refer to “How to say numbers” and “Making a call by entering a phone number” earlier in this section for more details.

#### “Redial” (C)

Use the Redial command to call the last number that was dialed within the vehicle.

#### NOTE:

**The system will not redial the last number dialed by the handset keypad.**

The system acknowledges the command, repeats the number and begins dialing.

If a redial number does not exist, the system announces, “There is no number to redial” and ends the VR session.

#### “Call back” (D)

Use the Call Back command to dial the number of the last incoming call within the vehicle.

The system acknowledges the command, repeats the number and begins dialing. If a call back number does not exist, the system announces, “There is no number to call back” and ends the VR session.

#### During a call

During a call there are several command options available. Press the “” button on the steering wheel to mute the receiving voice and enter commands.

- “Help” — The system announces the available commands.
- “Go back/Correction” — The system announces “Go back,” ends the VR session and returns to the call.
- “Cancel/Quit” — The system announces “Cancel,” ends the VR session and returns to the call.



- “Send/Enter/Call/Dial” — Use the Send command to enter numbers during a call. For example, if you were directed to dial an extension by an automated system:

Say: “Send one two three four.”

The system acknowledges the command and sends the tones associated with the numbers. The system then ends the VR session and returns to the call.

- “Transfer call” — Use the Transfer Call command to transfer the call from the Bluetooth® Hands-Free Phone System to the cellular phone when privacy is desired.

The system announces, “Transfer call. Call transferred to privacy mode.” The system then ends the VR session.

You can also issue the Transfer Call command again to return to a hands-free call through the vehicle.

- “Mute” — Use the Mute command to mute your voice so the other party cannot hear it. Use the mute command again to unmute your voice.

**NOTE:**

**If the other party ends the call or the cellular phone network connection is lost while the Mute feature is on, the Mute feature may need to be reset to “off.”**

**“Phone book”**

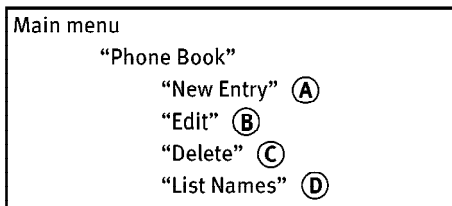

The Phone Book stores up to 40 names for each phone paired with the system. Each name can have up to 4 locations/phone numbers associated with it.

**NOTE:**

**Each phone has its own separate phone book. You cannot access Phone A’s phone book if you are currently connected with Phone B.**

**“New entry” (A)**

Use the New Entry command to store a new name in the system.

When prompted by the system, say the name you would like to give the new entry.

For example, say: “Mary.”

If the name is too long or too short, the system tells you, then prompts you for a name again.

Also, if the name sounds too much like a name already stored, the system tells you, then prompts you for a name again.

Once the system accepts the name and you confirm it is correct, the system asks for a location (Home, Office, Mobile or Other).

For example, say: “Home.”

The system acknowledges the location and asks for a number.

For example, say: “five five five one two one two.” See “How to say numbers” earlier in this section for more information.

The system repeats the number and prompts you for the next command. When you have finished entering numbers, choose “Store.”

The system confirms the name, location and number. The system then asks if you would like to store another location for the

same name. If you do not wish to store another location, the system ends the VR session.

#### “Edit” (B)

Use the Edit command to alter an existing phone book entry or to add a 2nd, 3rd or 4th phone number to an existing entry.

When prompted by the system, say the name of the entry you wish to edit.

The system acknowledges the name and asks you for the location you would like to edit.

Say the name of the location. The system acknowledges and asks you for the phone number you would like to store with this location.

See “How to say numbers” earlier in this section for more information.

The system repeats the number and prompts you for the next command. When you have finished entering numbers, choose “Store.”

The system confirms the name, location and number, then announces that the entry has been stored. The system then ends the VR session.

## 4-50 Display screen, heater, air conditioner and audio systems

#### “Delete” (C)

Use the Delete command to erase one entry from the phone book, all entries from the phone book, the current redial number or the current call back number.

To delete entries from the phone book, say a name or “All entries” when prompted by the system.

The system acknowledges the command and asks you to confirm the deletion.

To delete the current redial number or call back number, say “redial number” or “call back number” when prompted by the system.

If a redial number or a call back number exists, the system deletes them without asking for confirmation.

If there is no number for the entry you are trying to delete, the system says so and ends the VR session.

#### “List names” (D)

Use the List Names command to hear all the names and locations in the phone book.

The system recites the phone book entries but does not include the actual phone num-

bers. When the playback of the list is complete the system ends the VR session.

You can stop the playback of the list at any time by pressing the “MODE” button on the steering wheel. The system ends the VR session.

#### “Memo pad”

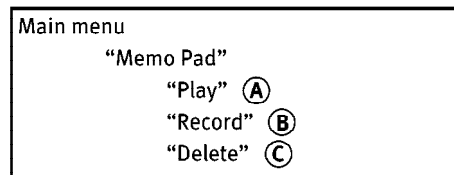

The Memo Pad records a maximum of 3 voice memos, each up to 20 seconds long.

#### “Play” (A)

The system plays back all the memos in the order of newest to oldest. The system ends the VR session.

If there are no memos recorded, the system announces “No messages to play.” The system ends the VR session.

## “Record” **(B)**

The system announces “Recording” and a tone sounds signaling you to begin.

Speak the information you wish to record clearly. When you are done, press the “” or “**MODE**” button on the steering wheel.

A tone sounds and the system announces “Memo recorded.” Another tone sounds to end the VR session.

If the memo pad is full, the system asks if you wish to record over the oldest memo.

## “Delete” **(C)**

The Delete command erases all memos. The system asks you to confirm this action before deleting all memos.

## “Setup”

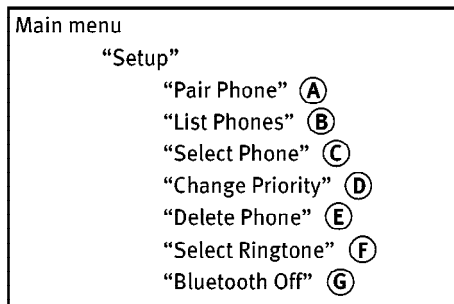

Use the Setup command to change options associated with the Bluetooth<sup>®</sup> Hands-Free Phone System.

### “Pair phone” **(A)**

Use the Pair Phone command to pair a phone to the Bluetooth<sup>®</sup> Hands-Free Phone System.

When you are asked to enter a PIN code for pairing your Bluetooth<sup>®</sup> cellular phone, operate it to enter the code “1234”.

The code is always “1234” regardless of the number of phones paired.

Up to 5 phones can be paired. If you try to pair a sixth phone, the system announces

that you must first delete one phone or replace an existing phone.

If you try to pair a phone that has already been paired to your vehicle’s system, the system announces the name the phone is already using. The pairing procedure will then be cancelled.

When prompted by the system, choose from the following commands:

- “New phone” — Refer to “Pairing a phone” earlier in this section.
- “Replace phone” — The system announces the names of the phones already paired and asks which you would like to replace.

Once you say the name of the phone you wish to replace, the pairing procedure will begin. Refer to “Pairing procedure” earlier in this section.

- “List phone” — See the description below.

### “List phones” **(B)**

Use the List Phone command to hear the names of the phones currently paired. If no phones are paired, the system announces, “No paired phones to list.” The system then ends the VR session.

### “Select phone” <sup>Ⓒ</sup>

Use the Select Phone command to select a phone of lesser priority when two or more phones paired with Bluetooth<sup>®</sup> Hands-Free Phone System are in the vehicle at the same time.

The system asks you to name the phone and confirm the selection.

Once the selection is confirmed, the selected phone remains active until the ignition switch is turned OFF or you select a new phone.

### “Change priority” <sup>Ⓓ</sup>

Use the Change Priority command to change the priority level of the active phone.

The priority level determines which phone is active when more than one paired Bluetooth<sup>®</sup> phone is in the vehicle.

The system states the priority level of the active phone and asks for a new priority level (1, 2, 3, 4, 5).

If the new priority level is already being used for another phone, the two phones will swap priority levels.

For example, if the current priority levels are:

Priority Level 1 = Phone A  
Priority Level 2 = Phone B  
Priority Level 3 = Phone C

and you change the priority level of Phone C to Level 1, then:

Priority Level 1 = Phone C  
Priority Level 2 = Phone B  
Priority Level 3 = Phone A

### “Delete phone” <sup>Ⓔ</sup>

Use the Delete Phone command to delete a specific phone or all phones from the Bluetooth<sup>®</sup> Hands-Free Phone System.

The system announces the names of the phones already paired with the system and their priority level. The system then gives you the option to delete a specific phone, all phones or listen to the list again.

Once you chose to delete a phone or all phones, the system asks you to confirm this action.

#### **NOTE:**

**When you delete a phone, the associated phone book for that phone will also be deleted.**

### “Select ringtone” <sup>Ⓕ</sup>

Use the Select Ringtone command to select the tone heard in the vehicle when an incoming call is received.

The system announces the name of the active phone and asks you to choose from the following commands:

- “Ringtone” — The system plays a ringtone and asks if you would like to select that tone. If you say no, the system plays the next ringtone available and continues to cycle through the ringtones until you select one or quit.
- “Silent” — The system asks you to confirm your wish to disable the ringtone.

### “Bluetooth off” <sup>Ⓖ</sup>

Use the Bluetooth Off command to turn off the Bluetooth<sup>®</sup> Hands-Free Phone System.

When Bluetooth<sup>®</sup> Hands-Free Phone System is off, you will not be able to make or receive calls using INFINITI Voice Recognition. Also, you will not have access to the Phone Book.

You can still use the Memo Pad and access Setup.

To turn on the system again, choose the Bluetooth On command from the Setup command.

## SPEAKER ADAPTATION (SA) MODE

Speaker Adaptation allows up to two out-of-dialect users to train the system to improve recognition accuracy. By repeating a number of commands, the users can create a voice model of their own voice that is stored in the system. The system is capable of storing a different speaker adaptation model for memory A and memory B.

If memory A is available, the system will use memory A to store the model. If memory A is in use and memory B is available, the system will use memory B to store the model. If both of the memory locations are in use, the system will ask the user to select which memory location should be overwritten.



### Training procedure

The procedure for training a voice is as follows.

1. Position the vehicle in a reasonably quiet outdoor location.

2. Sit in the driver's seat with the engine running, the parking brake on, and the transmission in Park.

3. Press and hold the “” button for more than 5 seconds.

4. The system announces: “Press the “PHONE/SEND ()” button for the hands-free phone system to enter the speaker adaptation mode or press the “PHONE/END ()” button to select a different language.”

5. Press the “” button.

For information on selecting a different language, see “Choosing a language” earlier in this section.

6. Voice memory A or memory B is selected automatically. If both memory locations are already in use, the system will prompt you to overwrite one. Follow the instructions provided by the system.

7. When preparation is complete and you are ready to begin, the press the “” button.

8. The SA mode will be explained. Follow the instructions provided by the system.

9. When training is finished, the system will tell you an adequate number of phrases have been recorded.

10. The system will ask you to say your name. Follow the instructions to register your name.

11. The system will announce that speaker adaptation has been completed and the system is ready.

The SA mode will stop if:

- The “” button is pressed for more than 5 seconds in SA mode.
- The vehicle is driven during SA mode.
- The ignition switch is turned to the OFF or LOCK position.

### Training phrases

During the SA mode, the system instructs the trainer to say the following phrases. (The timing of input phrases is indicated by the system.)

- Phrase 1
- Phrase 2

## TROUBLESHOOTING GUIDE

The system should respond correctly to all voice commands without difficulty. If problems are encountered, try the following solutions. Where the solutions are listed by number, try each solution in turn, starting with number 1, until the problem is resolved.

Symptom	Solution
System fails to interpret the command correctly.	1. Ensure that the command is valid. See “List of voice commands” earlier in this section.
	2. Ensure that the command is spoken after the tone.
	3. Speak clearly without pausing between words and at a level appropriate to the ambient noise level in the vehicle.
	4. Ensure that the ambient noise level is not excessive (for example, windows open or defroster on). NOTE: If it is too noisy to use the phone, it is likely that the voice commands will not be recognized.
	5. If more than one command was said at a time, try saying the commands separately.
	6. If the system consistently fails to recognize commands, the voice training procedure should be carried out to improve the recognition response for the speaker. See “Speaker adaptation (SA) mode” earlier in this section.
The system consistently selects the wrong entry from the phone book.	1. Ensure that the phone book entry name requested matches what was originally stored. This can be confirmed by using the “List Names” command. See “Phone book” earlier in this section.
	2. Replace one of the names being confused with a new name.

## INFINITI MOBILE ENTERTAINMENT SYSTEM (MES) (if so equipped)

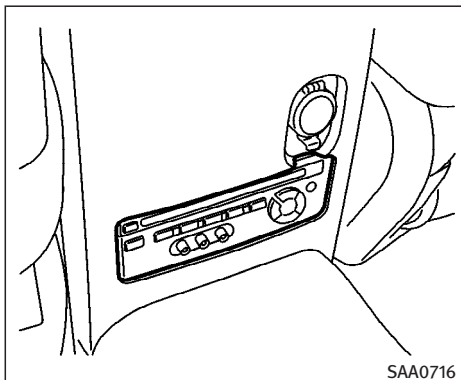

### WARNING

- The Mobile Entertainment System (MES) is designed for rear seat passenger viewing only.
- The driver must not attempt to operate the MES while the vehicle is in motion so that full attention may be given to vehicle operation.



### CAUTION

- The glass screen on the liquid crystal display may break if hit with a hard or sharp object. If the glass breaks, do not touch the liquid crystalline material, which contains a small amount of mercury. In case of contact with skin, wash immediately with soap and water.
- Use a damp, soft cloth when cleaning the Mobile Entertainment System components. Do not use solvents or cleaning solutions.
- Do not attempt to use the system in extreme temperature conditions [below  $-4^{\circ}\text{F}$  ( $-20^{\circ}\text{C}$ ) or above  $158^{\circ}\text{F}$  ( $70^{\circ}\text{C}$ )].
- To avoid draining the vehicle battery, do not operate the system more than 15 minutes without starting the engine.

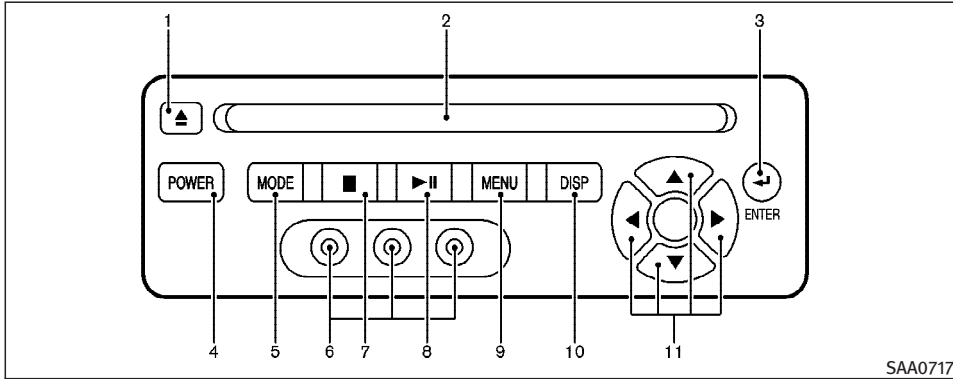

SAA0717

## DIGITAL VIDEO DISC (DVD) PLAYER CONTROLS

The DVD player has the following controls:

- |                        |                        |
|------------------------|------------------------|
| 1. "EJECT" button      | 8. "PLAY/PAUSE" button |
| 2. DVD slot            | 9. "MENU" button       |
| 3. "ENTER" button      | 10. "DISPLAY" button   |
| 4. POWER on/off switch | 11. NAVIGATION KEYS    |
| 5. "MODE" button       |                        |
| 6. Input jacks         |                        |
| 7. "STOP" button       |                        |

## 4-56 Display screen, heater, air conditioner and audio systems

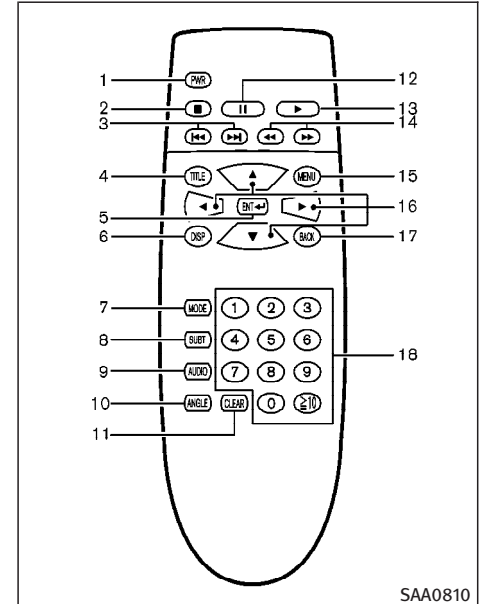

SAA0810

## REMOTE CONTROL

The remote control has the following controls:

1. "ON-OFF" button



2. "STOP" button
3. "NEXT TRACK/CHAPTER" and "PREVIOUS TRACK/CHAPTER" button
4. "TITLE" button
5. "ENTER" button
6. "DISPLAY" button
7. "MODE" button
8. "SUBTITLE" button
9. "AUDIO" button
10. "ANGLE" button
11. "CLEAR" button
12. "PAUSE" button
13. "PLAY" button
14. "FAST FORWARD/FAST REVERSE" button
15. "MENU" button
16. NAVIGATION KEYS
17. "RETURN" button
18. NUMERIC KEYPAD

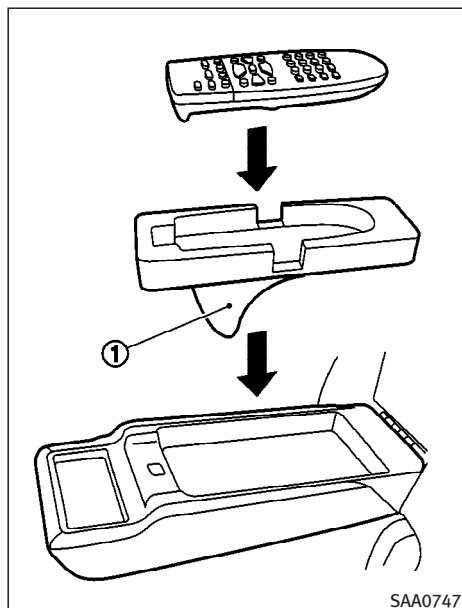

SAA0747

### REMOTE CONTROL HOLDER

Peel the sheet ① of the holder off, then put the remote control holder to the desired position in the rear armrest.

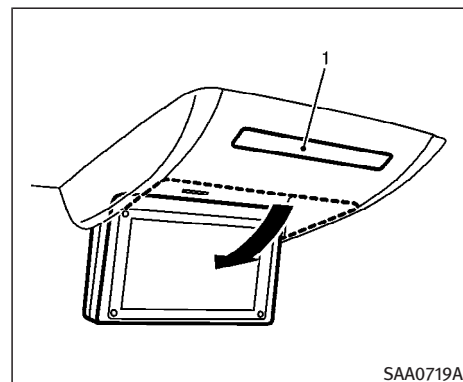

SAA0719A

1. Wireless remote controller receiver/  
Wireless headphones transmitter

### FLIP-DOWN SCREEN



### CAUTION

- The glass screen on the liquid crystal display may break if hit with a hard or sharp object. If the glass breaks, do not touch the liquid crystalline material,

which contains a small amount of mercury. In case of contact with skin, wash immediately with soap and water.

- The screen rotates down to view and up into the housing to store when not in use. Ensure that the screen is latched securely into the housing when stored.

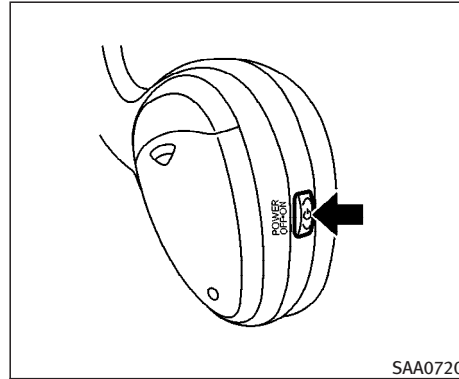

SAA0720

## Headphones

### Power ON/OFF:

Push the “POWER” button to turn the headphones on or off.

### Volume control:

Turn the volume control knob to adjust the volume.

The headphones will automatically be turned off in 30 seconds if there is no sound during that period. To prevent the battery from being discharged, keep the power supply turned off when not in use.

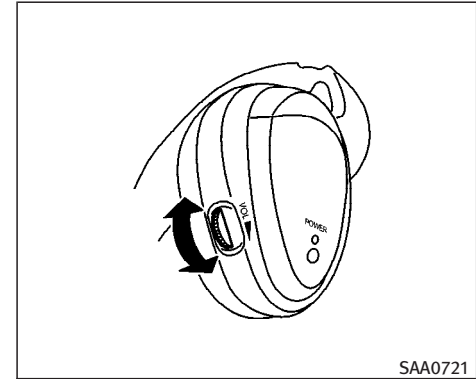

SAA0721

## PLAYING A DIGITAL VIDEO DISC (DVD)



### CAUTION

- Only operate the DVD while the vehicle engine is running. Operating the DVD for extended periods of time with the engine OFF can discharge the vehicle battery.
- Do not allow the system to get wet. Excessive moisture such as spilled liquids may cause the system to malfunction.

- The driver must not attempt to wear the headphones while the vehicle is in motion so that full attention may be given to vehicle operation.
- While playing video CD media, this DVD player does not guarantee complete functionality of all video CD formats.

With the DVD player, you can hear DVD videos, video CDs and CDs using headphones. Passengers in the rear seat can enjoy the sound independently of the front seat.

Using the “CD-DVD” button located on the front seat, you can also hear the sound of the DVD player through the speakers in the vehicle.

It is possible to operate the DVD player by remote control.

Headphones are a wireless type and no cables are necessary. You can use them in almost all the ranges in the rear seat. (It is not possible to use the headphones in the front seat.)

#### “POWER” on/off button:

With the ignition switch turned to the ACC or ON position, push the “POWER” button to turn the DVD player on or off.

Insert the compact disc into the slot with the label side facing up. The digital video disc will be guided automatically into the slot.



#### CAUTION

**Do not force the compact disc into the slot. This could damage the player.**

#### MODE select switch:

Push the Mode button to select Audio/Video source between DVD and AUX input (input jacks on the faceplate, Red = right channel audio input, White = left channel audio input, and Yellow = Video input).

The display will show the “AUX” in the upper left corner of the display for 4 seconds once the Mode is changed to AUX.

To use the input jacks, refer to “Auxiliary input jacks” in this section.



or



PLAY:

When the “PLAY/PAUSE” button on the player or the “PLAY” button on the remote control is pushed, the player will play.

In play mode, the display will show  on the upper left corner of the display.





**FF (Fast Forward), REW (Rewind) (Remote control only):**

Push “FAST FORWARD/FAST REVERSE” buttons to carry out the fast forward or fast reverse presentation at 5 times normal play speed.

Push “FAST FORWARD/FAST REVERSE” buttons again or “PLAY” button to resume the normal play speed.



**NEXT CHAPTER/  
PREVIOUS CHAPTER:**

When the “” (NEXT CHAPTER) button is pushed while the digital video disc is being played, the program next to the present one will start to play from its beginning. Push several times to skip through programs. The digital video disc will advance the number of times the button is pushed. When the “” (PREVIOUS CHAPTER)

button is pushed, the program being played returns to its beginning. Push several times to skip back through programs. The digital video disc will go back the number of times the button is pushed.



When the “PLAY/PAUSE” button on the player or the “PAUSE” button on the remote control is pushed, the player will pause playing of the media. In pause mode, the player will show  on the upper left corner of the display until the player is changed to another mode.



Push the “STOP” button once to stop playing the media. The display will show  in the upper left corner of the display for 4 seconds, and the last disc position will be stored. When the “PLAY” button is pushed again, it will resume at the stored disc track and time position.

If the “STOP” button is pushed again when the player is already in Stop mode, it will reinitialize the pointer to the beginning of the disc. In effect it will ignore the last stored disc position and upon receipt of the next play message it will begin at the

Title Menu, or at “the beginning of the disc”.



When the “EJECT” button is pushed with the digital video disc loaded, it will be ejected.

The display will show the EJECT symbol  in the upper left corner of the display for 4 seconds once the “EJECT” button is pushed.

If the digital video disc is not loaded, the display will show “NO DISC”.

If the digital video disc comes out and is not removed within 25 seconds, it will be pulled back into the slot to protect it.

#### **DISPLAY:**





If the DISPLAY control is pushed for less than 2 seconds, the display menu will appear on the screen.

- The display menu will remain on the screen for 10 seconds if no subsequent control activations occur.
- Use NAVIGATION KEYS to navigate within the display menu, and use ENTER to select the item.

- Holding the DISPLAY control on the faceplate for longer than approximately 2 seconds while in the display menu will reset the display characteristics to their nominal values. (Faceplate feature only)

If the DISPLAY control button on the faceplate is pushed for more than 2 seconds, the media track/time information will be displayed along the bottom of the display. Pushing the DISPLAY control for more than 2 seconds will remove the media track/time information from the display. (Faceplate feature only)

#### **NAVIGATION KEYS:**

If media is in PLAY mode, activation of the NAVIGATION KEYS (Up, Down, Left, and Right) will perform the following functions: next chapter/track, previous chapter/track, fast reverse and fast forward, and the display will show ,  and ,  respectively in the upper left corner of the display for 4 seconds. (Faceplate feature only)

If media is in PAUSE mode, activation of the NAVIGATION KEYS (Up, down and Right) will perform the following functions: next chapter/track, previous chapter/track and slow forward, and the display will

show **▶|** , **|◀** and **▶|** respectively in the upper left corner of the display for 4 seconds. (Faceplate feature only)

If media is in activated MENU mode, the NAVIGATION KEYS will be used to navigate Up, Down, Left, and Right within the menu.

If display control menu is on, the NAVIGATION KEYS will be used to navigate Up, Down, Left, and Right within the menu.

#### **“ENTER”:**

In MENU mode, push the “ENTER” button to select MENU items.

In the display menu, push the “ENTER” button to select items for modification, as per the on-screen instructions.

#### **“MENU”:**

If the media is in PLAY mode and the “MENU” button is pressed, the DVD menu will appear on the screen. Use Navigation Keys to navigate within the menu, and use ENTER to select the item.

Push the “MENU” button again to return to PLAY mode.

#### **TITLE (Remote control only):**

Push “TITLE” button to return the DVD media to the “title” of the DVD.

Push “TITLE” button again to return to the previous stop point and play.

#### **RETURN (Remote control only):**

Push RETURN function to exit the current active menu and return to the previous menu.

#### **SUBTITLES (Remote control only):**

Push the “SUBTITLES” button to call-up subtitle selection menu.

Repeatedly press the “SUBTITLE” button to cycle through each available subtitle.

#### **AUDIO (Remote control only):**

Push the “AUDIO” button to call-up audio menu.

Repeatedly press the “AUDIO” button to cycle through each available audio track.

#### **ANGLE (Remote control only):**

Push the “ANGLE” button to call-up camera angle menu.

Repeatedly press the ANGLE button to cycle through each available angle.

#### **CLEAR (Remote control only):**

Push the “CLEAR” button to clear all numeric inputs, if actuated prior to expiration of the 3-second timer.

#### **NUMERIC KEYPAD (0-9 & ≥10) (Remote control only):**

Push the NUMERIC KEYPAD to directly access disc chapters, titles or tracks by inputting their numeric value.

The “≥10” button input numbers greater than or equal to 10, allowing up three digits to be input for selecting chapter/title/track number.

The subsequent actuation of numeric buttons will continuously shift the previously input number to the “left”.

The chapter/title/track number will be automatically selected (if valid, based on media content) if 3 seconds expire without any keypad inputs.

The operator can cancel the input chapter/title/track number by actuating the CLEAR control prior to the expiration of the 3-second timer.

These functions can be used only for the DVD discs which correspond to them.

#### **Auxiliary input jacks**

The auxiliary input jacks are located on the control panel. Compatible devices such as video games camcorders and portable

video players can be connected to the auxiliary jacks.

The auxiliary jacks are color coded for identification purposes.

- Yellow - video input
- White - left channel audio input
- Red - right channel audio input

## CARE AND MAINTENANCE

Use a lightly dampened, lint free cloth to clean the surfaces of your Mobile Entertainment System. (DVD player face, screen, remote control, etc.)



### CAUTION

- Do not use any solvents or cleaning solutions when cleaning the video system.
- Do not use excessive force on the monitor screen.
- Avoid touching or scratching the monitor screen as it may become dirty or damaged.

- Do not attempt to operate the system in extreme temperature conditions [below  $-4^{\circ}\text{F}$  ( $-20^{\circ}\text{C}$ ) and above  $158^{\circ}\text{F}$  ( $70^{\circ}\text{C}$ )].
- Do not attempt to operate the system in extreme humidity conditions (less than 10% or more than 75%).

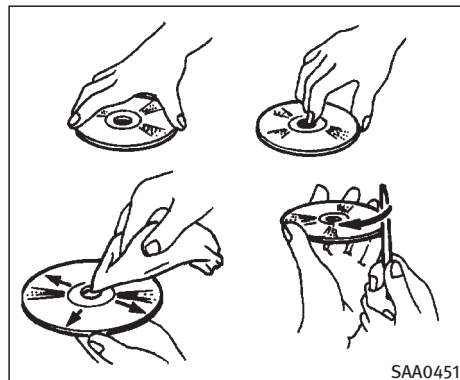

## HOW TO HANDLE THE DVD



### CAUTION

- Handle a DVD by its edges. Never touch the surface of the disc.
- To clean a disc, wipe the surface from the center to the outer edge using a clean, soft cloth. Do not wipe the disc using a circular motion.

- Do not use a conventional record cleaner, benzine, thinner or alcohol intended for industrial use.
- A new disc may be rough on its inner and outer edges. Remove the rough edges using the side of a pen or pencil as illustrated.
- Never attempt to use a DVD that has been cracked, deformed, or repaired using adhesive. Doing so may cause damage to the equipment.

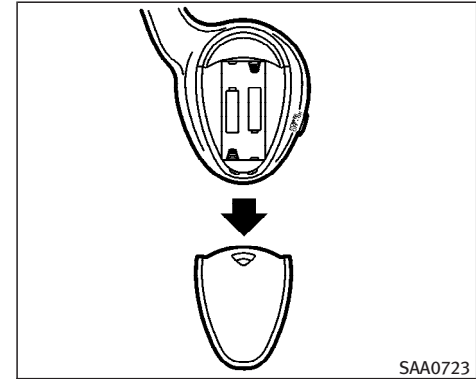
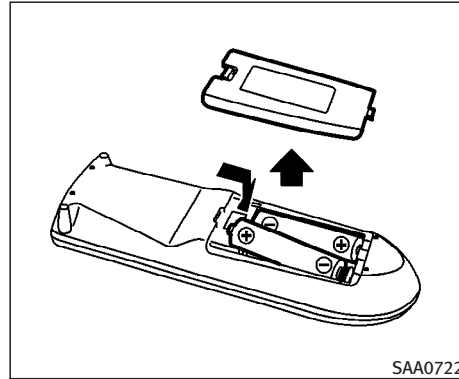

- Handle the DVD carefully to avoid contamination or flaws. Otherwise, signals may not be read properly.
- Do not write, draw or attach anything on any side of the DVD.
- Do not store the DVD in locations with direct sunlight or in high temperatures or humidity.
- Always place discs in the storage case when they are not being used.
- Do not put on any sticker or write anything on either surface of the DVD.

## Remote control and headphones battery replacement

Replace the battery as follows:

1. Open the lid.
2. Replace both batteries with new ones.
  - Size AA (remote control)
  - Size AAA (headphones)

Make sure that the ⊕ and ⊖ ends on the batteries match the markings inside the compartment.

3. Close the lid securely.

If the battery is removed for any reason other than replacement, perform step 3 above.

- If you will not be using the remote control for long periods of time, remove the batteries.
- Replacement of the batteries is needed when the remote control only functions

at extremely close distances to the MES or not at all.

- Be careful not to touch the battery terminal.
- An improperly disposed battery can harm the environment. Always confirm local regulations for battery disposal.
- When changing batteries, do not let dust or oil get on the remote control and headphones.

#### FCC Notice:

Changes or modifications not expressly approved by the party responsible for compliance could void the user's authority to operate the equipment. This device complies with Part 15 of the FCC Rules and RSS-210 of Industry Canada. Operation is subject to the following two conditions: (1) This device may not cause harmful interference, and (2) this device must accept any interference received, including interference that may cause undesired operation of the device.

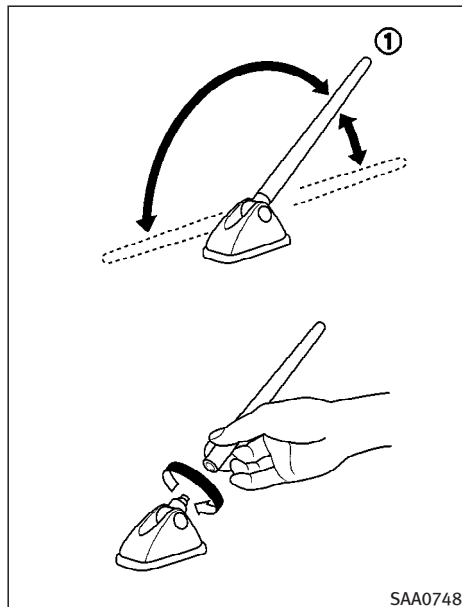

SAA0748

## ANTENNA

### Placing the antenna

You can adjust the antenna to three different positions manually.

INFINITI recommends position ① for the best radio reception

### Removing the antenna

You can remove the antenna if necessary.

Hold the bottom of the antenna and remove by turning counterclockwise.



## CAUTION

- Be sure that antenna is removed before the vehicle enters an automatic car wash.
- Be sure to fold down the antenna before the vehicle enters a garage with a low ceiling.



## CAR PHONE OR CB RADIO

When installing a CB, ham radio or car phone in your INFINITI, be sure to observe the following cautions, otherwise the new equipment may adversely affect the engine control system and other electronic parts.



### WARNING

- A cellular telephone should not be used while driving so full attention may be given to vehicle operation. Some jurisdictions prohibit the use of cellular telephones while driving.
- If you must make a call while your vehicle is in motion, the hands free cellular phone operational mode (if so equipped) is highly recommended. Exercise extreme caution at all times so full attention may be given to vehicle operation.
- If a conversation in a moving vehicle requires you to take notes, pull off the road to a safe location and stop your vehicle before doing so.



### CAUTION

- Keep the antenna as far as possible away from the electronic control modules.
- Keep the antenna wire more than 8 in (20 cm) away from the electronic control system harnesses. Do not route the antenna wire next to any harness.
- Adjust the antenna standing-wave ratio as recommended by the manufacturer.
- Connect the ground wire from the CB radio chassis to the body.
- For details, consult an INFINITI dealer.

# 5 Starting and driving

Precautions when starting and driving .....	5-2	Parking brake .....	5-18
Exhaust gas (Carbon monoxide) .....	5-2	Lane departure warning (LDW) system (if so equipped) .....	5-19
Three-way catalyst .....	5-3	Precautions on lane departure warning (LDW) system .....	5-19
On-pavement and off-road driving precautions (for AWD models) .....	5-3	Lane departure warning (LDW) system operation .....	5-20
Tire pressure monitoring system (TPMS) (for models without run-flat tire only) .....	5-3	Cruise control .....	5-22
Tire pressure monitoring system (TPMS) (for models with run-flat tire only) .....	5-5	Precautions on cruise control .....	5-22
Avoiding collision and rollover .....	5-7	Cruise control operations .....	5-23
Drinking alcohol/drugs and driving .....	5-7	Intelligent cruise control system (if so equipped) .....	5-24
Driving safety precautions .....	5-8	Selecting the vehicle-to-vehicle distance control mode .....	5-25
Ignition switch (except Intelligent Key system) .....	5-10	Vehicle-to-vehicle distance control mode ...	5-26
Key positions .....	5-11	Precautions on vehicle-to-vehicle distance control mode .....	5-26
INFINITI vehicle immobilizer system .....	5-11	Vehicle-to-vehicle distance mode operation .....	5-28
Ignition switch (models with the Intelligent Key system) .....	5-12	Conventional (fixed speed) cruise control mode .....	5-41
Ignition switch positions .....	5-12	Preview function (for Intelligent Cruise Control system equipped models) .....	5-45
INFINITI vehicle immobilizer system .....	5-13	Break-in schedule .....	5-45
Before starting the engine .....	5-13		
Starting the engine .....	5-14		
Driving the vehicle .....	5-14		
Automatic transmission .....	5-14		

Increasing fuel economy .....	5-45
All-wheel drive (AWD) (if so equipped) .....	5-46
Parking/parking on hills.....	5-48
Power steering.....	5-49
Brake system.....	5-49
Braking precautions .....	5-49
Brake assist.....	5-50
Brake assist .....	5-50
Brake assist (with preview function) (Intelligent Cruise Control system equipped model) .....	5-50

Anti-lock brake system (ABS) .....	5-52
Vehicle dynamic control (VDC) system .....	5-54
Cold weather driving .....	5-56
Freeing a frozen door lock .....	5-56
Anti-freeze .....	5-56
Battery.....	5-56
Draining of coolant water .....	5-56
Tire equipment .....	5-56
Special winter equipment .....	5-57
Driving on snow or ice.....	5-57
Engine block heater (if so equipped).....	5-57

## PRECAUTIONS WHEN STARTING AND DRIVING



### WARNING

- Do not leave children or adults who would normally require the support of others alone in your vehicle. Pets should also not be left alone. They could accidentally injure themselves or others through inadvertent operation of the vehicle. Also, on hot, sunny days, temperatures in a closed vehicle could quickly become high enough to cause severe or possibly fatal injuries to people or animals.
- Properly secure all cargo to help prevent it from sliding or shifting. Do not place cargo higher than the seatbacks. In a sudden stop or collision, unsecured cargo could cause personal injury.

## EXHAUST GAS (Carbon monoxide)



### WARNING

Do not breathe exhaust gases; they con-

tain colorless and odorless carbon monoxide. Carbon monoxide is dangerous. It can cause unconsciousness or death.

- If you suspect that exhaust fumes are entering the vehicle, drive with all windows fully open, and have the vehicle inspected immediately.
- Do not run the engine in closed spaces such as a garage.
- Do not park the vehicle with the engine running for any extended length of time.
- Keep the lift gate closed while driving, otherwise exhaust gases could be drawn into the passenger compartment. If you must drive with the lift gate open, follow these precautions:
  1. Open all the windows.
  2. Set the air recirculation switch OFF and the fan control at maximum position to circulate the air.
- If electrical wiring or other cable connections must pass to a trailer through

the seal on the lift gate or the body, follow the manufacturer's recommendation to prevent carbon monoxide entry into the vehicle.

- If a special body, camper or other equipment is added for recreational or other usage, follow the manufacturer's recommendation to prevent carbon monoxide entry into the vehicle. (Some recreational vehicle appliances such as stoves, refrigerator, heaters, etc. may also generate carbon monoxide.)
- The exhaust system and body should be inspected by a qualified mechanic whenever:
  - a. The vehicle is raised for service.
  - b. You suspect that exhaust fumes are entering into the passenger compartment.
  - c. You notice a change in the sound of the exhaust system.
  - d. You have had an accident involving damage to the exhaust system, underbody, or rear of the vehicle.

## THREE-WAY CATALYST

The three-way catalyst is an emission control device installed in the exhaust system. Exhaust gases in the converter are burned at high temperatures to help reduce pollutants.



### WARNING

- The exhaust gas and the exhaust system are very hot. Keep people, animals or flammable materials away from the exhaust system components.
- Do not stop or park the vehicle over flammable materials such as dry grass, waste paper or rags. They may ignite and cause a fire.



### CAUTION

- Do not use leaded gasoline. Deposits from leaded gasoline will seriously reduce the three-way catalyst's ability to help reduce exhaust pollutants.

- **Keep your engine tuned up. Malfunctions in the ignition, fuel injection, or electrical systems can cause overrich fuel flow into the three-way catalyst, causing it to overheat. Do not keep driving if the engine misfires, or if noticeable loss of performance or other unusual operating conditions are detected. Have the vehicle inspected promptly by an INFINITI dealer.**
- **Avoid driving with an extremely low fuel level. Running out of fuel could cause the engine to misfire, damaging the three-way catalyst.**
- **Do not race the engine while warming it up.**
- **Do not push or tow your vehicle to start the engine.**

## ON-PAVEMENT AND OFF-ROAD DRIVING PRECAUTIONS (for AWD models)

**Utility vehicles have a significantly higher rollover rate than other types of vehicles.**

They have higher ground clearance than passenger cars to make them capable of performing in a variety of on-pavement and off-road applications. This gives them a higher center of gravity than ordinary cars. An advantage of higher ground clearance is a better view of the road, allowing you to anticipate problems. However, they are not designed for cornering at the same speeds as conventional two-wheel drive vehicles any more than low-slung sports cars are designed to perform satisfactorily under off-road conditions. If at all possible, avoid sharp turns or abrupt maneuvers particularly at high speeds. As with other vehicles of this type, failure to operate this vehicle correctly may result in loss of control or vehicle rollover. In a rollover crash, an unbelted person is significantly more likely to die than a person wearing a seatbelt.

## TIRE PRESSURE MONITORING SYSTEM (TPMS) (for models without run-flat tire only)

Each tire, including the spare (if provided), should be checked monthly when cold and inflated to the inflation pressure recommended by the vehicle manufacturer on the vehicle placard or tire inflation pressure label. (If your vehicle has tires of a different

size than the size indicated on the vehicle placard or tire inflation pressure label, you should determine the proper tire inflation pressure for those tires.)

As an added safety feature, your vehicle has been equipped with a tire pressure monitoring system (TPMS) that illuminates a low tire pressure telltale when one or more of your tires is significantly under-inflated. Accordingly, when the low tire pressure telltale illuminates, you should stop and check your tires as soon as possible, and inflate them to the proper pressure. Driving on a significantly under-inflated tire causes the tire to overheat and can lead to tire failure. Under-inflation also reduces fuel efficiency and tire tread life, and may affect the vehicle's handling and stopping ability.

Please note that the TPMS is not a substitute for proper tire maintenance, and it is the driver's responsibility to maintain correct tire pressure, even if under-inflation has not reached the level to trigger illumination of the TPMS low tire pressure telltale.

Your vehicle has also been equipped with a TPMS malfunction indicator to indicate when the system is not operating properly.

#### 5-4 Starting and driving

The TPMS malfunction indicator is combined with the low tire pressure telltale. When the system detects a malfunction, the telltale will flash for approximately one minute and then remain continuously illuminated. This sequence will continue upon subsequent vehicle start-ups as long as the malfunction exists. When the malfunction indicator is illuminated, the system may not be able to detect or signal low tire pressure as intended. TPMS malfunctions may occur for a variety of reasons, including the installation of replacement or alternate tires or wheels on the vehicle that prevent the TPMS from functioning properly. Always check the TPMS malfunction telltale after replacing one or more tires or wheels on your vehicle to ensure that the replacement or alternate tires and wheels allow the TPMS to continue to function properly.

#### Additional information

- The TPMS does not monitor the tire pressure of the spare tire.
- The TPMS will activate only when the vehicle is driven at speeds above 16 MPH (25 km/h). Also, this system may not detect a sudden drop in tire pres-

sure (for example a flat tire while driving).

- Tire pressure rises and falls depending on the heat caused by the vehicle's operation and the outside temperature. Low outside temperature can lower the temperature of the air inside the tire which can cause a lower tire inflation pressure. This may cause the low tire pressure warning light to illuminate. If the warning light illuminates in low ambient temperature, check the tire pressure for all four tires.
- You can also check the pressure of all tires (except the spare tire) on the display screen. The order of the tire pressure figures displayed on the screen does not correspond with the actual order of the tire position. See "Tire pressure information" in the "4. Display screen, heater, air conditioner and audio system" section.

For additional information, see "Low tire pressure warning light" in the "2. Instruments and controls" section and "Tire pressure monitoring system (TPMS)" in the "6. In case of emergency" section.

## TIRE PRESSURE MONITORING SYSTEM (TPMS) (for models with run-flat tire only)

Each tire, including the spare (if provided), should be checked monthly when cold and inflated to the inflation pressure recommended by the vehicle manufacturer on the vehicle placard or tire inflation pressure label. (If your vehicle has tires of a different size than the size indicated on the vehicle placard or tire inflation pressure label, you should determine the proper tire inflation pressure for those tires.)

As an added safety feature, your vehicle has been equipped with a tire pressure monitoring system (TPMS) that illuminates a low tire pressure telltale when one or more of your tires is significantly under-inflated. Accordingly, when the low tire pressure telltale illuminates, you should stop and check your tires as soon as possible, and inflate them to the proper pressure. Driving on a significantly under-inflated tire causes the tire to overheat and can lead to tire failure. Under-inflation also reduces fuel efficiency and tire tread life, and may affect the vehicle's handling and stopping ability.

If the vehicle is being driven with one or more flat tires, the warning light will flash continuously and a chime will sound for 10 seconds. The chime will only sound at the first indication of a flat tire and the warning light will flash continuously. When the Flat tire warning is activated, have the system reset and the tire checked and replaced if necessary by an INFINITI dealer. Even if the tire is inflated to the specified COLD tire pressure, the warning light will continue to flash until the system is reset by an INFINITI dealer.

Your vehicle can be driven for a limited time on a flat tire. See "Run-flat tires (if so equipped)" in the "8. Maintenance and do-it-yourself" section.

Please note that the TPMS is not a substitute for proper tire maintenance, and it is the driver's responsibility to maintain correct tire pressure, even if under-inflation has not reached the level to trigger illumination of the TPMS low tire pressure telltale.

Your vehicle has also been equipped with a TPMS malfunction indicator to indicate when the system is not operating properly. The TPMS malfunction indicator is combined with the low tire pressure telltale.

When the system detects a malfunction, the telltale will flash for approximately one minute and then remain continuously illuminated. This sequence will continue upon subsequent vehicle start-ups as long as the malfunction exists. When the malfunction indicator is illuminated, the system may not be able to detect or signal low tire pressure as intended. TPMS malfunctions may occur for a variety of reasons, including the installation of replacement or alternate tires or wheels on the vehicle that prevent the TPMS from functioning properly. Always check the TPMS malfunction telltale after replacing one or more tires or wheels on your vehicle to ensure that the replacement or alternate tires and wheels allow the TPMS to continue to function properly.

### **Additional information:**

- The TPMS does not monitor the tire pressure of the spare tire.
- The TPMS will activate only when the vehicle is driven at speeds above 16 MPH (25 km/h). Also, this system may not detect a sudden drop in tire pressure (for example a flat tire while driving).

- Tire pressure rises and falls depending on the heat caused by the vehicle's operation and the outside temperature. Low outside temperature can lower the temperature of the air inside the tire which can cause a lower tire inflation pressure. This may cause the low tire pressure warning light to illuminate. If the warning light illuminates in low ambient temperature, check the tire pressure for all four tires.
- You can also check the pressure of all tires (except the spare tire) on the display screen. The order of the tire pressure figures displayed on the screen does not correspond with the actual order of the tire position. See "Tire pressure information" in the "4. Display screen, heater, air conditioner and audio systems" section.

For additional information, see "Low tire pressure warning light" in the "2. Instruments and controls" section, "Tire pressure monitoring system" in the "6. In case of emergency" section.



## WARNING

- If the low tire pressure warning light illuminates while driving, avoid sudden steering maneuvers or abrupt braking, reduce vehicle speed, pull off the road to a safe location and stop the vehicle as soon as possible. Serious vehicle damage could occur and may lead to an accident and could result in serious personal injury. Check the tire pressure for all four tires. Adjust the tire pressure to the recommended COLD tire pressure shown on the Tire and Loading Information label to turn the low tire pressure warning light OFF. If you have a flat tire, replace it with a spare tire as soon as possible. (See "Flat tire" in the "6. In case of emergency" section for changing a flat tire.)
- Although you can continue driving with a punctured run-flat tire (if so equipped), remember that vehicle handling stability is reduced, which could lead to an accident and personal injury. Also, driving a

long distance at high speeds may damage the tires.

- Do not drive at speeds above 55 MPH (88 km/h) and do not drive more than 50 miles (80 km) with a punctured run-flat tire (if so equipped). The actual distance the vehicle can be driven on a flat tire depends on outside temperature, vehicle load, road conditions and other factors.
- Do not tow a trailer when a run-flat tire (if so equipped) is flat.
- When a spare tire is mounted or a wheel is replaced, tire pressure will not be indicated, the TPMS will not function and the low tire pressure warning light will flash. Contact your INFINITI dealer as soon as possible for tire replacement and/or system resetting.
- Replacing tires with those not originally specified by INFINITI could affect the proper operation of the TPMS.
- Do not inject any tire liquid or aerosol tire sealant into the tires, as this may cause a malfunction of the tire pressure sensors.





## CAUTION

Do not place metalized film or any metal parts (antenna, etc.) on the windows. This may cause poor reception of the signals from the tire pressure sensors, and the TPMS will not function properly.

### FCC Notice:

Changes or modifications not expressly approved by the party responsible for compliance could void the user's authority to operate the equipment.

This device complies with Part 15 of the FCC Rules and RSS-210 of Industry Canada.

Operation is subject to the following two conditions: (1) This device may not cause harmful interference, and (2) this device must accept any interference received, including interference that may cause undesired operation of the device.

## AVOIDING COLLISION AND ROLLOVER



## WARNING

Failure to operate this vehicle in a safe and prudent manner may result in loss of control or an accident.

Be alert and drive defensively at all times. Obey all traffic regulations. Avoid excessive speed, high speed cornering, or sudden steering maneuvers, because these driving practices could cause you to lose control of your vehicle. **As with any vehicle, a loss of control could result in a collision with other vehicles or objects, or cause the vehicle to rollover, particularly if the loss of control causes the vehicle to slide sideways.** Be attentive at all times, and avoid driving when tired. Never drive when under the influence of alcohol or drugs (including prescription or over-the-counter drugs which may cause drowsiness). Always wear your seat belt. See "Seat belts" in the "1. Safety — Seats, seat belts and supplemental restraint system" section and also instruct your passengers to do so.

Seat belts help reduce the risk of injury in collisions and rollovers. **In a rollover crash, an unbelted or improperly belted person is significantly more likely to be injured or killed than a person properly wearing a seat belt.**

## DRINKING ALCOHOL/DRUGS AND DRIVING



## WARNING

**Never drive under the influence of alcohol or drugs. Alcohol in the bloodstream reduces coordination, delays reaction time and impairs judgment. Driving after drinking alcohol increases the likelihood of being involved in an accident injuring yourself and others. Additionally, if you are injured in an accident, alcohol can increase the severity of the injury.**

INFINITI is committed to safe driving. You must not drive under the influence of alcohol. Every year thousands of people are injured or killed in alcohol related accidents. Although the local laws vary on what is considered to be legally intoxicated, the fact is that alcohol affects all people differ-

ently and most people underestimate the effects of alcohol.

Remember, drinking and driving don't mix! And that's true for drugs too (over the counter, prescription, and illegal drugs). Don't drive if your ability to operate your vehicle is impaired by alcohol, drugs, or some other physical condition.

## DRIVING SAFETY PRECAUTIONS

Please observe the following precautions:



### WARNING

- Drive carefully when off the road and avoid dangerous areas. Every person who drives or rides in this vehicle should be seated with their seat belt fastened. This will keep you and your passengers in position when driving over rough terrain.
- Before driving up or down grades, check the road surface for bumps or potholes. Be sure to climb a gentle slope and descend a gentle slope.

- Do not drive across steep slopes. Instead drive either straight up or straight down the slopes. Off-road vehicles can tip over sideways much more easily than they can forward or backward.
- Many hills are too steep for any vehicle. If you drive up them, you may stall. If you drive down them, you may not be able to control your speed. If you drive across them, you may roll over.
- Do not move the selector lever while driving on downhill grades as this could cause loss of control of the vehicle.
- Be sure to use the engine brake. The foot brake performance may be reduced, resulting in a possible accident.
- Stay alert when driving to the top of a hill. At the top there could be a drop-off or other hazard that could cause an accident.
- If your engine stalls or you cannot make it to the top of a steep hill, never attempt to turn around. Your vehicle could tip or roll over. Always back straight down in R

(Reverse) range. Never back down in N(Neutral), using only the brake, as this could cause loss of control.

- Heavy braking going down a hill could cause your brakes to overheat and fade, resulting in loss of control and an accident. Apply brakes lightly and use a low range to control your speed.
- Unsecured cargo can be thrown around when driving over rough terrain. Properly secure all cargo so it will not be thrown forward and cause injury to you or your passengers.
- To avoid raising the center of gravity excessively, do not exceed the rated capacity of the roof rack and evenly distribute the load. Secure heavy loads in the cargo area as far forward and as low as possible. Do not equip the vehicle with tires larger than specified in this manual. This could cause your vehicle to roll over.
- Do not grip the inside or spokes of the steering wheel when driving off-road. The steering wheel could move suddenly and injure your hands. Instead drive

with your fingers and thumbs on the outside of the rim.

- Before operating the vehicle, ensure that the driver and all passengers have their seat belts fastened.
- Always drive with the floor mats in place as the floor may become hot.
- Lower your speed when encountering strong crosswinds. With a higher center of gravity, your INFINITI is more affected by strong side winds. Slower speeds ensure better vehicle control.
- Do not drive beyond the performance capability of the tires, even with AWD engaged. Accelerating quickly, sharp steering maneuvers or sudden braking may cause loss of control.
- If at all possible, avoid sharp turning maneuvers, particularly at high speeds. Your INFINITI all-wheel drive vehicle has a higher center of gravity than a two-wheel drive vehicle. The vehicle is not designed for cornering at the same speeds as conventional two-wheel drive

vehicles. Failure to operate this vehicle correctly could result in loss of control and/or a rollover accident.

- Always use tires of the same type, size, brand, construction (bias, bias-belted or radial), and tread pattern on all four wheels. Install tire chains on the rear wheels when driving on slippery roads and drive carefully.
- Be sure to check the brakes immediately after driving in mud or water. See “Brake system” later in this section.
- Avoid parking your vehicle on steep hills. If you get out of the vehicle and it rolls forward, backward or sideways, you could be injured.
- Whenever you drive off-road through sand, mud or water as deep as the wheel hub, more frequent maintenance may be required. See the maintenance schedule in the “INFINITI Service and Maintenance Guide”.
- Do not drive continuously on sandy or muddy roads with the rear wheels spin-

ning. The AWD warning light blinks and the driving mode changes to 2WD. This could reduce traction force remarkably. Be especially careful when towing a trailer. (AWD models)

- A vehicle equipped with AWD (All-Wheel Drive) should never be tested using a two wheel dynamometer (such as the dynamometers used by some states for emissions testing), or similar equipment. Make sure you inform test facility personnel that your vehicle is equipped with AWD before it is placed on a dynamometer. Using the wrong test equipment may result in transmission damage or unexpected vehicle movement which could result in serious vehicle damage or personal injury.
- Never operate the accelerator pedal with any wheels raised and the other wheels on the ground while jacking up or with any wheels on a roller and the other wheels on the ground. Otherwise, the vehicle could lurch forward or backward. (AWD models)

- When a wheel is off the ground due to an unlevel surface, do not spin the wheel excessively. (AWD models)
- When the vehicle is on a free roller or the front or rear wheels are jacked up, do not start the engine. The vehicle could lurch forward. (AWD models)

## IGNITION SWITCH (except Intelligent Key system)

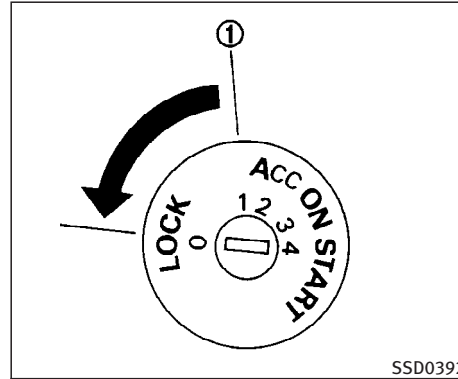

The ignition lock is designed so that the key cannot be turned to LOCK and removed until the selector lever is moved to the P (Park) position.

When removing the key from the ignition, make sure the selector lever is in the P (Park) position.

If the selector lever is not returned to P (Park) position, the key cannot be moved toward LOCK.

When the key cannot be turned toward the LOCK position, proceed as follows to remove the key:

1. Move the selector lever into the P (Park) position.
2. Turn the ignition key slightly in the ON direction.
3. Turn the key toward the LOCK position.
4. Remove the key.

If the key is removed from the ignition switch, the selector lever cannot be moved from P (Park) position. **The selector lever can be moved if the ignition switch is in the ON position and the foot brake pedal is depressed.**

There is an OFF position (1) in between LOCK and ACC, although it does not show on the lock cylinder. When the ignition is in OFF the steering wheel is not locked.

In order for the steering wheel to be locked, it must be turned about 1/6 of a turn clockwise from the straight up position.

**To lock the steering wheel, turn the key to the LOCK position. Remove the key. To unlock the steering wheel, insert the key and turn it gently while rotating the steering wheel slightly right and left.**



## WARNING

Never remove or turn the key to the LOCK position while driving. The steering wheel will lock. This may cause the driver to lose control of the vehicle and could result in serious vehicle damage or personal injury.

### KEY POSITIONS

The switch includes an anti-theft steering lock device.

LOCK (Normal parking position) (0)

The ignition key can only be removed when the switch is in this position.

OFF (1)

The engine can be turned off without locking the steering wheel.

The ignition lock is designed so that the key cannot be turned to LOCK and removed until the selector lever is moved to the P (Park) position.

ACC (Accessories) (2)

This position activates electrical accesso-

ries such as the radio when the engine is not running.

ON (Normal operating position) (3)

This position turns on the ignition system and the electrical accessories.

START (4)

This position activates the starter motor, starting the engine.

### INFINITI VEHICLE IMMOBILIZER SYSTEM

The INFINITI Vehicle Immobilizer System will not allow the engine to start without the use of the registered key.

If the engine fails to start using a registered key (for example, when interference is caused by another registered key, an automated toll road device or automated payment device on the key ring), restart the engine using the following procedures:

1. Leave the ignition switch in the ON position for approximately 5 seconds.
2. Turn the ignition switch to the OFF or LOCK position and wait approximately 10 seconds.
3. Repeat step 1 and 2.

4. Restart the engine while holding the device (which may have caused the interference) separate from the registered key.

If this procedure allows the engine to start, INFINITI recommends placing the registered key on a separate key ring to avoid interference from other devices.

## IGNITION SWITCH (models with the Intelligent Key system)

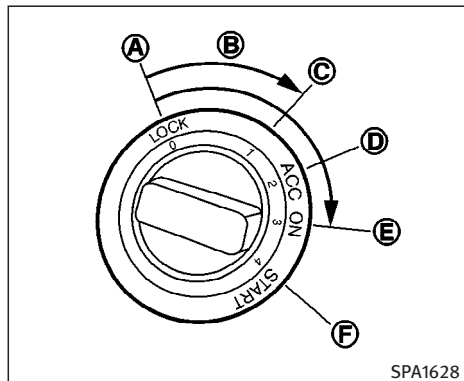

The ignition lock is designed so that the ignition switch cannot be turned to the LOCK position and removed until the selector lever is moved to the P (Park) position.

When turning the ignition switch, make sure the selector lever is in the P position.

If the selector lever is not returned to the P position, the ignition switch cannot be moved toward the LOCK position.

When the ignition switch cannot be turned toward the LOCK position while keeping the Intelligent Key, proceed as follows:

### 5-12 Starting and driving

1. Move the selector lever into the P position.
2. Turn the ignition switch slightly in the ON direction.
3. Turn the key toward the LOCK position.

**The selector lever can be moved from P position if the ignition switch is in the ON position and the foot brake pedal is depressed.**

There is an OFF position (C) in between LOCK and ACC, although it does not show on the lock cylinder. When the ignition is in OFF the steering wheel is not locked.

In order for the steering wheel to be locked, it must be turned about 1/6 of a turn counterclockwise from the straight up position.

**To lock the steering wheel, turn the ignition switch to the LOCK position. To unlock the steering wheel, push the ignition switch in and turn it gently while rotating the steering wheel slightly right and left.**

**If the battery of the vehicle equipped with the Intelligent Key system is discharged, the ignition switch cannot be turned from the LOCK position, even using the mechanical key or valet key.**



## WARNING

**Never turn the ignition switch to the LOCK position while driving. The steering wheel will lock. This may cause the driver to lose control of the vehicle and could result in serious vehicle damage or personal injury.**

## IGNITION SWITCH POSITIONS

Push in the ignition switch to the (B) range when you turn it.

### LOCK (Normal parking position):

The ignition switch can only be locked in the (A) position.

The ignition switch will be unlocked when it is pushed in, and turned to the ACC position (D) while carrying the Intelligent Key.

### ACC (Accessories) (D):

This position activates electrical accessories such as the radio, when the engine is not running.

### **ON (Normal operating position) (E):**

This position turns on the ignition system and electrical accessories.

### **START (F):**

This position starts the engine. As soon as the engine has started, release the knob immediately. It will automatically return to the ON position.

The ignition switch cannot be turned back to the LOCK position unless the shift lever is in P position. (It can be turned to only (C).)



### **CAUTION**

**Do not leave the vehicle with the ignition switch in ACC or ON positions when the engine is not running for an extended period. This can discharge the battery.**

## **INFINITI VEHICLE IMMOBILIZER SYSTEM**

The INFINITI Vehicle Immobilizer System will not allow the engine to start without the use of the registered key.

If the engine fails to start using a regis-

tered key (for example, when interference is caused by another registered key, an automated toll road device or automated payment device on the key ring), restart the engine using the following procedures:

1. Leave the ignition switch in the ON position for approximately 5 seconds.
2. Turn the ignition switch to the OFF or LOCK position and wait approximately 10 seconds.
3. Repeat step 1 and 2.
4. Restart the engine while holding the device (which may have caused the interference) separate from the registered key.

If this procedure allows the engine to start, INFINITI recommends placing the registered key on a separate key ring to avoid interference from other devices.

## **BEFORE STARTING THE ENGINE**

- Make sure the area around the vehicle is clear.
- Maintenance items should be checked periodically, for example, each time you check engine oil.
- Check that all windows and lights are clean.
- Visually inspect tires for their appearance and condition. Also, check tires for proper inflation.
- Lock all doors.
- Position seat and adjust head restraints.
- Adjust inside and outside mirrors.
- Fasten seat belts and ask all passengers to do likewise.
- Check the operation of warning lights when the ignition switch is turned to the ON (3) position.

## STARTING THE ENGINE

1. Apply the parking brake.
2. Move the selector lever to P (Park) or N (Neutral). (P preferred.)

The starter is designed not to operate if the selector lever is in one of the driving positions.

3. Crank the engine **with your foot off the accelerator pedal** by turning the ignition key to START. Release the key when the engine starts. If the engine starts, but fails to run, repeat the above procedure.
- If the engine is very hard to start in extremely cold weather or when re-starting, depress the accelerator pedal a little (approximately 1/3 to the floor) and hold it then crank the engine. Release the key and the accelerator pedal when the engine starts.
- If the engine is very hard to start because it is flooded, depress the accelerator pedal all the way to the floor and hold it. Crank the engine for 5 to 6 seconds. After cranking the engine, release the accelerator pedal. Crank the engine **with your foot off the accelerator pedal** by turning the ignition switch to START. Release the key when

the engine starts. If the engine starts, but fails to run, repeat the above procedure.



### CAUTION

**Do not operate the starter for more than 15 seconds at a time. If the engine does not start, turn the key off and wait 10 seconds before cranking again, otherwise the starter could be damaged.**

#### 4. Warm-up

Allow the engine to idle for at least 30 seconds after starting. Do not race the engine while warming it up. Drive at moderate speed for a short distance first, especially in cold weather.

In cold weather, keep the engine running for a minimum of 2 to 3 minutes before shutting it off. Starting and stopping the engine over a short period of time may make the vehicle more difficult to start.

## DRIVING THE VEHICLE

### AUTOMATIC TRANSMISSION

#### 5-speed automatic transmission

The automatic transmission in your vehicle is electronically controlled by a transmission control module to produce maximum power and smooth operation.

Shown on the following pages are the recommended operating procedures for this transmission. Follow these procedures for maximum vehicle performance and driving enjoyment.

#### Starting the vehicle

After starting the engine, fully depress the foot brake pedal and push the selector lever button before shifting the selector lever to the R (Reverse), N (Neutral), D (Drive) or Manual shift mode position. Be sure the vehicle is fully stopped before attempting to shift the selector lever.

**This automatic transmission model is designed so that the foot brake pedal must be depressed before shifting from P (Park) to any drive position while the ignition switch is ON.**

**The selector lever cannot be moved out of P (Park) position and into any of the other gear positions if the ignition key is turned**



to the **LOCK, OFF** or **ACC** position or if the key is removed from the switch.

1. Keep the foot brake pedal depressed and push the selector lever button to shift into a driving gear.
2. Release the parking brake and foot brake, then gradually start the vehicle in motion.



## WARNING

- Do not depress the accelerator pedal while shifting from P (Park) or N (Neutral) to R (Reverse), D (Drive) or manual shift mode. Always depress the brake pedal until shifting is completed. Failure to do so could cause you to lose control and have an accident.
- Cold engine idle speed is high, so use caution when shifting into a forward or reverse gear before the engine has warmed up.
- On slippery roads, do not downshift. This may cause a loss of control.

- Never shift to P (Park) or R (Reverse) while the vehicle is moving forward. Never shift to P (Park) or D (Drive) while the vehicle is moving rearward. These could cause an accident.



## CAUTION

When stopping the vehicle on an uphill grade, do not hold the vehicle by depressing the accelerator pedal. The foot brake should be used for this purpose.

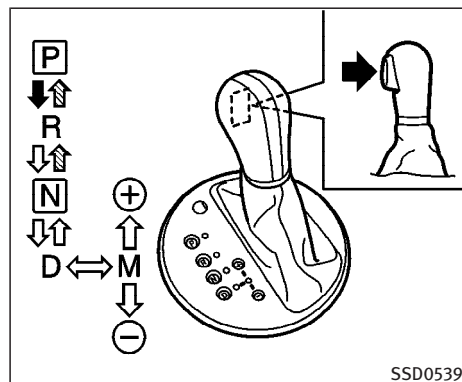

To move the selector lever,

- ➡ : Push the button while depressing the brake pedal,
- ➡ (with diagonal lines) : Push the button,
- ⇄ : Just move the selector lever.

## Shifting

After starting the engine, fully depress the brake pedal and shift the selector lever from P (Park) to R (Reverse), N (Neutral), D (Drive), or Manual shift mode position.

Push the button to shift into P (Park) or R (Reverse). All other positions can be selected without pushing the button.



## WARNING

Apply the parking brake if the selector lever is in any position while the engine is not running. Failure to do so could cause the vehicle to move unexpectedly or roll away and result in serious personal injury or property damage.

If the key is turned to OFF or ACC for any reason while the vehicle is in R (Reverse), N (Neutral), or any D (Drive) position, the key cannot be turned to LOCK and be removed from the ignition switch. Move the selector lever to P (Park) position, then the key can be turned to LOCK.

### P (Park):

Use this selector position when the vehicle is parked or when starting the engine. Make sure the vehicle is completely stopped. **The brake pedal must be depressed and the selector lever button pushed in to move the selector lever from N (Neutral) or any drive position to P (Park).** Apply the parking brake. When parking on a hill, apply the parking brake first, then move the lever to the P (Park) position.

## 5-16 Starting and driving



## CAUTION

Use this position only when the vehicle is completely stopped.

### R (Reverse):

Use this position to back up. Always be sure the vehicle is completely stopped before selecting R (Reverse). **The brake pedal must be depressed and the selector lever button pushed in to move the selector lever from P (Park), N (Neutral) or any drive position to R (Reverse).**

### N (Neutral):

Neither forward nor reverse gear is engaged. The engine can be started in this position. You may shift to N (Neutral) and restart a stalled engine while the vehicle is moving.

### D (Drive):

Use this position for all normal forward driving.

## Manual shift mode

When the selector lever is shifted from D to the manual shift gate with the vehicle

stopped or while driving, the transmission enters the manual shift mode. Shift range can be selected manually.

In the manual shift mode, the shift range is displayed on the position indicator in the meter.

Shift ranges up or down one by one as follows:

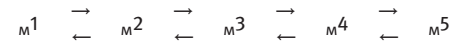

### m5 (5th):

Use this position for all normal forward driving.

### m4 (4th):

For driving up or down long slopes where engine braking would be advantageous.

### m3 (3rd) and m2 (2nd):

Use for hill climbing or engine braking on downhill grades.

### m1 (1st):

Use this position when climbing steep hills slowly or driving slowly through deep snow, sand or mud, or for maximum engine braking on steep downhill grades.

- Remember not to drive at high speeds for extended periods of time in lower

than  $M4$  range. This reduces fuel economy.

- When shifting up, move the selector lever to the + (up) side. (Shifts to higher range.)
- When shifting down, move the selector lever to the – (down) side. (Shifts to lower range.)
- Moving the selector lever to the same side twice will shift the ranges in succession. However, if this motion is rapidly done, the second shifting may not be completed properly.
- **In the manual shift mode, the transmission automatically shifts down to 1st gear before the vehicle comes to a stop. When accelerating again, it is necessary to shift up to the desired range.**
- When canceling the manual shift mode, return the selector lever to the D position. The transmission returns to the normal driving mode.
- **In the manual shift mode, the transmission may not shift to the selected gear. This helps maintain driving performance and reduces the chance of vehicle damage or loss of control.**

### Accelerator downshift — In D position —

For passing or hill climbing, fully depress the accelerator pedal to the floor. This shifts the transmission down into the lower gear, depending on the vehicle speed.

### Fail-safe

When fail-safe operation occurs, the automatic transmission will be locked in 4th gear.

**If the vehicle is driven under extreme conditions, such as excessive wheel spinning and subsequent hard braking, the fail-safe system may be activated. This will occur even if all electrical circuits are functioning properly. In this case, turn the ignition switch to the OFF position and wait for 3 seconds. Then turn the switch back to the ON position. The vehicle should return to its normal operating condition. If it does not return to its normal operating condition, have an INFINITI dealer check the transmission and repair if necessary.**

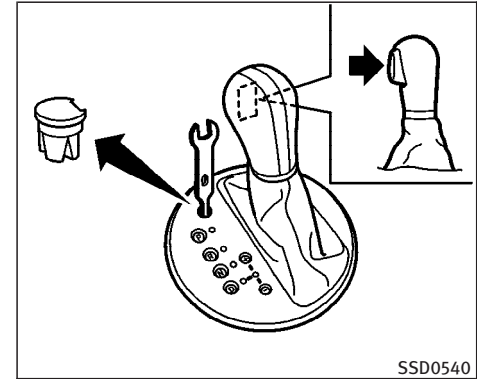

### Shift lock release

If the battery charge is low or discharged, the selector lever may not be moved from the P (Park) position even with the brake pedal depressed.

To move the selector lever, apply the parking brake, depress the brake pedal, and push the shift lock release button. The selector lever can be moved to N (Neutral). This allows the vehicle to be moved if the battery is discharged.

## PARKING BRAKE

If the lever cannot be moved out of P (Park), have an INFINITI dealer check the automatic transmission system as soon as possible.



**To apply:** Fully depress the parking brake pedal.

### To release:

1. Firmly apply the foot brake.
2. Depress the parking brake pedal and the parking brake will be released.
3. Before driving, be sure the brake warning light goes out.



## WARNING

- Be sure the parking brake is fully released before driving. Failure to do so can cause brake failure and lead to an accident.
- Do not release the parking brake from outside the vehicle.
- Do not use the gear shift in place of the parking brake. When parking, be sure the parking brake is fully engaged.
- Do not leave children unattended in a vehicle. They could release the parking brake and cause an accident.

## LANE DEPARTURE WARNING (LDW) SYSTEM (if so equipped)

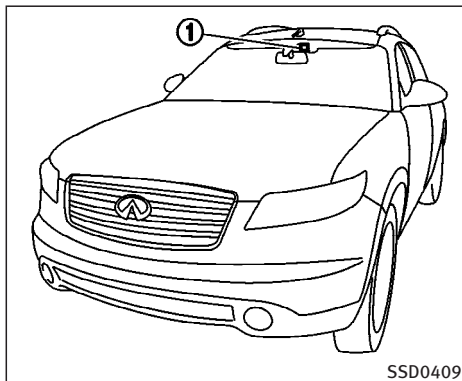

The Lane Departure Warning (LDW) system warns the driver when the vehicle is traveling close to either the left or the right of a traveling lane with detectable lane markers. It operates at approximately 45 MPH (72 km/h) and above. The system monitors lane markers of the traveling lane using the camera unit ① located inside the map light cover.

When the camera unit detects that the vehicle is traveling close to either the left or the right of the traveling lane, the LDW indicator ② on the instrument panel flashes and a chime sounds to alert the driver.

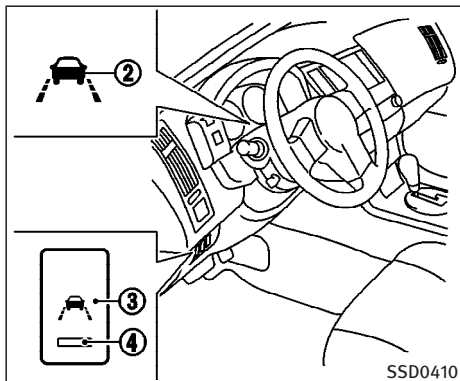

The LDW system can be turned on or off by pushing the LDW switch ③. When the system is on, the LDW system ON indicator ④ illuminates.

## PRECAUTIONS ON LANE DEPARTURE WARNING (LDW) SYSTEM



### WARNING

- This system is only a warning device to inform the driver of an unintended lane departure. It will not steer the vehicle or prevent loss of control. It is the driver's responsibility to stay alert, drive safely, keep the vehicle in the traveling lane, and be in control of the vehicle at all times.
- The system will not operate at speeds below approximately 45 MPH (72 km/h) or if it cannot detect lane markers.
- If the lane departure warning system malfunctions, it will cancel automatically. The LDW indicator light in the instrument panel will then illuminate (orange).

- If the LDW indicator light illuminates (orange), park the vehicle in a safe place. Turn the engine off and re-start the engine. If the LDW indicator light continues to illuminate, have the system checked by an INFINITI dealer.
- Excessive noise will interfere with warning system chime sound and the chime may not be heard.
- The system may not function properly under the following conditions:
  - On roads where the lane markers are faded or are not painted clearly.
  - On roads where the lane markers are painted yellow.
  - On roads where water, dirt or snow is covering the lane markers.
- The system may not monitor the lane markers in certain road, weather or driving conditions.
  - On roads where there are sharp curves.
  - Where the traveling lane merges or separates.

- On roads where the discontinued lane markers are present, such as near tollgates.
- On roads where there are no general lane markers.
- On roads where the lane width is too narrow.
- During bad weather (rain, fog, snow, etc.).
- When strong light (for example, at sunrise or sunset) is directly shining on the front of the vehicle in the camera.
- When entering or exiting a tunnel where a sudden change in brightness occurs.
- When traveling close to the vehicle in front of you, which obstructs the camera detection range.
- When the vehicle's traveling direction does not align with the lane marker.
- When rain, snow or dirt adhere to the windshield in front of the LDW camera.

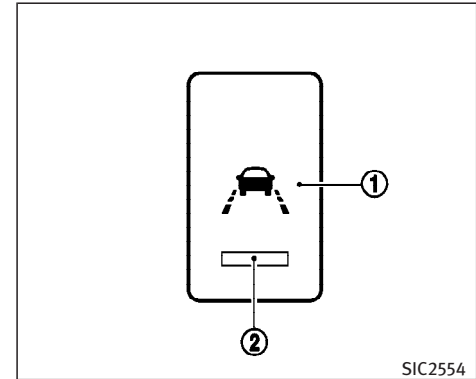

SIC2554

## LANE DEPARTURE WARNING (LDW) SYSTEM OPERATION

The LDW system has an automatic mode and manual mode.

In the automatic mode, the LDW system automatically turns on when the ignition switch is turned to the ON position. The LDW system ON indicator (2) located on the LDW switch (1) illuminates, indicating that the system is on.

To cancel the LDW system, push the LDW switch ① to turn off the LDW system ON indicator ②. To turn on the system, push the LDW switch ① again.

In the manual mode, the LDW system will be off when the ignition switch is turned to the ON position. The LDW switch must be pushed to turn on the system.

To change modes, push and hold the LDW switch ① for more than 4 seconds when the LDW system ON indicator ② is off. A chime will sound and blinking of the LDW system indicator indicates that the mode change has been completed.

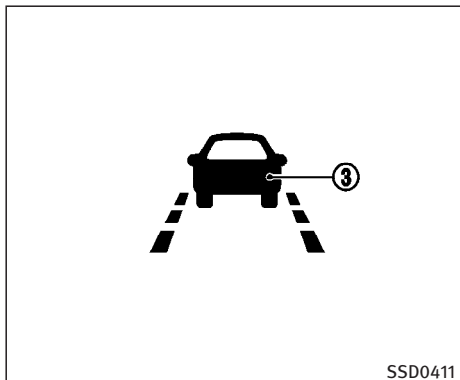

When the vehicle approaches either the left or the right of the traveling lane while driving over approximately 45 MPH (72 km/h), the LDW indicator ③ on the instrument panel flashes and a chime sounds to alert the driver.

When you use the lane change signal and change your traveling lane, the LDW system will enter the standby mode until the lane change is completed. Once the vehicle completes the lane change and the camera detects lane markers, the LDW system starts again to monitor lane markers.

When the vehicle speed lowers to less than approximately 45 MPH (72 km/h), the LDW system enters standby mode. When the vehicle speed increases to more than 45 MPH (72 km/h) again, the LDW system activates.

### Temporary disabled status at high temperature

If the vehicle is parked in direct sunlight under high temperature conditions (over approximately 104°F (40°C)) and then started, the lane departure warning system may cancel automatically. The LDW switch ON indicator will blink.

When the interior temperature is reduced, the system will again operate automatically and the LDW switch ON indicator illuminates.

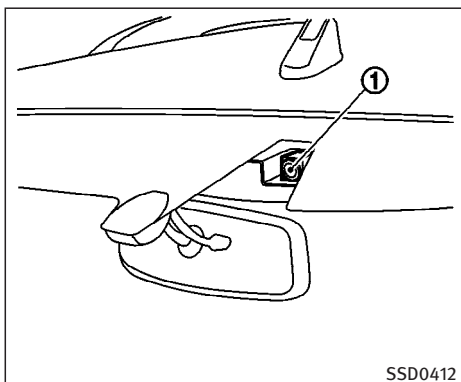

## Lane Departure Warning (LDW) camera unit maintenance

The LDW camera unit ① for the LDW system is located inside the map light cover.

To keep the LDW system operating properly, be sure to observe the following:

- Always keep the windshield clean. The sensing capability of the camera unit depends on the condition of the windshield. See “Cleaning interior” in the “7. Appearance and care” section for cleaning instruction.

### 5-22 Starting and driving

- Do not strike or damage the areas around the camera unit. Do not touch the camera lens or remove the screw located on the camera unit. Doing so could cause failure or malfunction. If the camera unit is damaged due to an accident, contact an INFINITI dealer.
- Do not attach a sticker (including transparent material) or install an accessory near the camera unit. This could cause failure or malfunction.
- Do not place reflective materials, such as a white paper or mirrors on the instrument panel. Reflection of the sunlight may adversely affect the camera unit’s lane marker detection capability.

## CRUISE CONTROL



### WARNING

**Do not use the cruise control when driving under the following conditions:**

- it is not possible to keep the vehicle at a set speed.
- in heavy traffic or in traffic that varies in speed.
- on winding or hilly roads.
- on slippery roads (rain, snow, ice, etc.).
- in very windy areas.

**Doing so could cause a loss of vehicle control and result in an accident.**

## PRECAUTIONS ON CRUISE CONTROL

- If the cruise control system malfunctions, it cancels automatically. The SET indicator light on the meter panel then blinks to warn the driver.
- If the engine coolant temperature becomes excessively high, the cruise control system will be canceled automatically.



- If the SET indicator light blinks, turn the cruise control main switch off and have the system checked by an INFINITI dealer.
- The SET indicator light may blink when the cruise control main switch is turned on while pushing the RESUME/ACCELERATE, SET/COAST, or CANCEL switch. To properly set the cruise control system, perform the preceding steps in the order indicated.

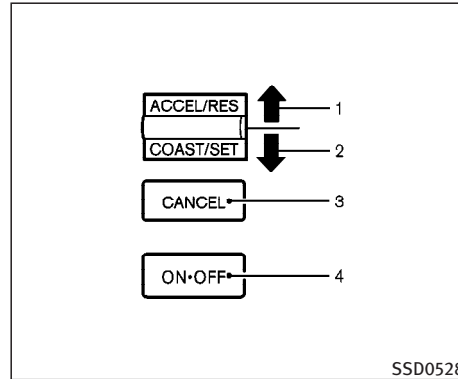

1. RESUME/ACCELERATE switch
2. SET/COAST switch
3. CANCEL switch
4. MAIN (ON-OFF) switch

## CRUISE CONTROL OPERATIONS

The cruise control allows driving at a speed between 25 to 89 MPH (40 to 144 km/h) without keeping your foot on the accelerator pedal.

**To turn on the cruise control**, push the main switch on. The CRUISE indicator light on the meter panel will come on.

**To set at cruising speed**, accelerate your vehicle to the desired speed, push the SET/COAST switch and release it. (The SET indicator light will come on.) Take your foot off the accelerator pedal. Your vehicle will maintain the set speed.

- **To pass another vehicle**, depress the accelerator pedal. When you release the pedal, the vehicle will return to the previously set speed.
- The vehicle may not maintain the set speed when going up or down steep hills. If this happens, drive without the cruise control.

**To cancel the preset speed**, follow either of these three methods:

- a) Push the cancel switch. The SET indicator light will go out.
  - b) Tap the brake pedal. The SET indicator light will go out.
  - c) Turn the main switch off. Both the CRUISE indicator and SET indicator lights will go out.
- If you depress the brake pedal while pushing the RESUME/ACCELERATE set switch and reset at the cruising speed, turn the main switch off once and then turn it on again.

- The cruise control will automatically be cancelled if the vehicle slows down below approximately 8 MPH (13 km/h).
- Move the selector lever to N (Neutral) position. The SET indicator light will go out.

**To reset at a faster cruising speed**, use one of the following three methods:

- Depress the accelerator pedal. When the vehicle attains the desired speed, push and release the SET/COAST switch.
- Push and hold the RESUME/ACCELERATE set switch. When the vehicle attains the speed you desire, release the switch.
- Push, then quickly release the RESUME/ACCELERATE set switch. Each time you do this, the set speed will increase by about 1 MPH (1.6 km/h).

**To reset at a slower cruising speed**, use one of the following three methods:

- Lightly tap the brake pedal. When the vehicle attains the desired speed, push the SET/COAST switch and release it.

- Push and hold the SET/COAST switch. Release the switch when the vehicle slows down to the desired speed.
- Push, then quickly release the SET/COAST switch. Each time you do this, the set speed will decrease by about 1 MPH (1.6 km/h).

**To resume the preset speed**, push and release the RESUME/ACCELERATE set switch. The vehicle will resume the last set cruising speed when the vehicle speed is over 25 MPH (40 km/h).

## INTELLIGENT CRUISE CONTROL SYSTEM (if so equipped)

The Intelligent Cruise Control (ICC) system automatically maintains a selected distance from the vehicle traveling in front of you according to that vehicle's speed (up to the set speed), or at the set speed when the road ahead is clear.

The ICC function can be set to one of two cruise control modes:

- Vehicle-to-vehicle distance control mode:

For maintaining a selected distance between your vehicle and the vehicle in front of you up to the preset speed.

- Conventional (fixed speed) cruise control mode:

For cruising at a preset speed.



### WARNING

- Always drive carefully and attentively when using either cruise control mode. Read and understand the Owner's Manual thoroughly before using the cruise control. To avoid serious injury or death, do not rely on the system to prevent accidents or to control the vehicle's

speed in emergency situations. Do not use cruise control except in appropriate road and traffic conditions.

- In the conventional (fixed speed) cruise control mode, a warning buzzer will not sound to warn you if you are too close to the vehicle ahead. Pay special attention to the distance between your vehicle and the vehicle ahead of you or a collision could occur.

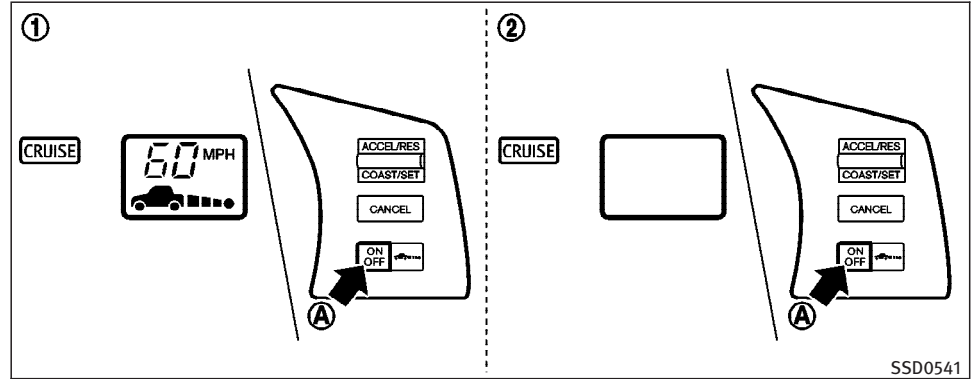

1. Vehicle-to-vehicle distance control mode
2. Conventional (fixed speed) cruise control mode

Push the MAIN switch (A) to choose the cruise control mode between ① the vehicle-to-vehicle distance control mode and ② the conventional (fixed speed) cruise control mode.

Always confirm the setting in the Intelligent Cruise Control system display.

For the vehicle-to-vehicle distance control mode, see the following description. For

the conventional (fixed speed) cruise control mode, see page 5-40.

## SELECTING THE VEHICLE-TO-VEHICLE DISTANCE CONTROL MODE

To choose the vehicle-to-vehicle distance control mode ①, quickly push and release the MAIN switch (A).

Once a control mode is activated, it cannot be changed to the other cruise control mode. To change the mode, push the MAIN switch once to turn the system off. Then push the MAIN switch again to turn the

system back on and select the desired cruise control mode.

## VEHICLE-TO-VEHICLE DISTANCE CONTROL MODE

In the vehicle-to-vehicle distance control mode, the Intelligent Cruise Control (ICC) system automatically maintains a selected distance from the vehicle traveling in front of you according to that vehicle's speed (up to the set speed), or at the set speed when the road ahead is clear.

With ICC, the driver can maintain the same speed as other vehicles without the constant need to adjust the set speed as you would with a normal cruise control system.

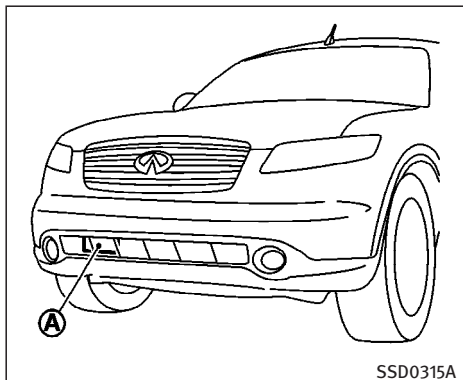

## PRECAUTIONS ON VEHICLE-TO-VEHICLE DISTANCE CONTROL MODE

The system is intended to enhance the operation of the vehicle when following a vehicle traveling in the same lane and direction.

If the distance sensor (A) detects a slower moving vehicle ahead, the system will reduce the vehicle speed so that your vehicle follows the vehicle in front at the selected distance.

The system automatically controls the throttle and applies the brakes (up to 25% of vehicle braking power) if necessary.

The detection range of the sensor is approximately 390 ft (120 m) ahead.



## WARNING

- This system is only an aid to assist the driver and is not a collision warning or avoidance device. It is the driver's responsibility to stay alert, drive safely and be in control of the vehicle at all times.
- The system is primarily intended for use on straight, dry, open roads with light traffic. It is not advisable to use the system in city traffic or congested areas.
- This system will not adapt automatically to road conditions. This system should be used in evenly flowing traffic. Do not use the system on roads with sharp curves, or on icy roads, in heavy rain or in fog.

The distance sensor will not detect under most conditions:

- Stationary and slow moving vehicles
- Pedestrians or objects in the roadway
- Oncoming vehicles in the same lane
- Motorcycles traveling offset in the travel lane

**This system will not automatically brake the vehicle to a stop.**



## WARNING

- As there is a performance limit to the distance control function, never rely solely on the Intelligent Cruise Control system. This system does not correct careless, inattentive or absent-minded driving, or overcome poor visibility in rain, fog, or other bad weather. Decelerate the vehicle speed by depressing the brake pedal, depending on the distance to the vehicle ahead and the surrounding circumstances in order to maintain a safe distance between vehicles.

- Although the brake operation is controlled by the system, the system does not automatically stop the vehicle. If the vehicle speed falls below approximately 20 MPH (32 km/h), the Intelligent Cruise Control system is automatically canceled and a warning chime sounds. (The brake control is also canceled.)
- The system may not detect the vehicle in front of you in certain road or weather conditions. To avoid accidents, never use the Intelligent Cruise Control system under the following conditions:
  - On roads where the traffic is heavy or there are sharp curves
  - On slippery road surfaces such as on ice or snow, etc.
  - During bad weather (rain, fog, snow, etc.)
    - When the windshield wiper is operated at the low speed (LO) or high speed (HI) position, the Intelligent Cruise Control system is automatically canceled.

- When strong light (for example, at sunrise or sunset) is directly shining on the front of the vehicle
- When rain, snow or dirt adhere to the system sensor
- On steep downhill roads (the vehicle may go beyond the set vehicle speed and frequent braking may result in overheating the brakes)
- On repeated uphill and downhill roads
- When traffic conditions make it difficult to keep a proper distance between vehicles because of frequent acceleration or deceleration
- Do not use the Intelligent Cruise Control system if you are towing a trailer. The system may not detect a vehicle ahead.
- In some road or traffic conditions, a vehicle or object can unexpectedly come into the sensor detection zone and cause automatic braking. You may need to control the distance from other vehicles

using the accelerator pedal. Always stay alert and avoid using the ICC system when it is not recommended in this section.

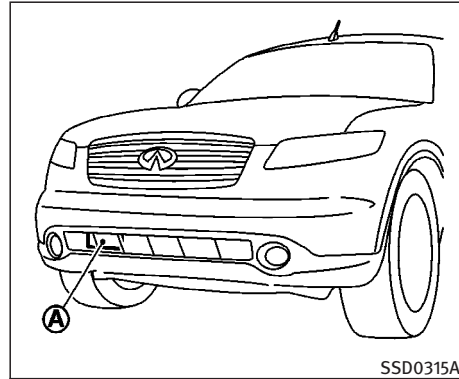

## VEHICLE-TO-VEHICLE DISTANCE MODE OPERATION

Always pay attention to the operation of the vehicle and be ready to manually control the proper following distance. The vehicle-to-vehicle distance control mode of the Intelligent Cruise Control (ICC) system may not be able to maintain the selected distance between vehicles (following distance) or selected vehicle speed under some circumstances.

The vehicle-to-vehicle distance control mode uses a sensor (A) located on the front of the vehicle to detect vehicles traveling

ahead. The sensor generally detects the signals returned from the reflectors on a vehicle ahead. Therefore, if the sensor cannot detect the reflector on the vehicle ahead, the ICC system may not maintain the selected distance.

The following are some conditions in which the sensor cannot detect the signals:

- When the reflector of the vehicle ahead is positioned high on the vehicle (trailer, etc.)
- When the reflector on the vehicle ahead is missing, damaged or covered
- When the reflector of the vehicle ahead is covered with dirt, snow and road spray
- When the snow or road spray from traveling vehicles reduces the sensor's visibility
- When dense exhaust or other smoke (black smoke) from vehicles reduces the sensor's visibility
- When excessively heavy baggage is loaded in the rear seat or the trunk of your vehicle

- When your vehicle is towing a trailer, etc.

The ICC system is designed to automatically check the sensor's operation. When the sensor is covered with dirt or obstructions, the system will automatically be canceled. If the sensor is covered with ice, a transparent or translucent vinyl bag, etc., the ICC system may not detect them. In these instances, the vehicle-to-vehicle distance control mode may not cancel and may not be able to maintain the selected following distance from the vehicle ahead. Be sure to check and clean the sensor regularly.

The vehicle-to-vehicle distance control mode is designed to maintain a selected distance and reduce the speed to match the slower vehicle ahead; the system will decelerate the vehicle as necessary. However, the ICC system can only apply up to 25% of the vehicle's total braking power. This system should only be used when traffic conditions allow vehicle speeds to remain fairly constant or when vehicle speeds change gradually. If a vehicle moves into the traveling lane ahead or if a vehicle traveling ahead rapidly decelerates, the distance between vehicles may become closer because the ICC system

cannot decelerate the vehicle quickly enough. If this occurs, the ICC system will sound a warning chime and blink the system display to notify the driver to take necessary action.

The system will cancel and a warning chime will sound if the speed falls below approximately 20 MPH (32 km/h). The system will also disengage below the 20 MPH (32 km/h) cut-off speed or over the maximum set speed.

Refer to "Approach warning" later in this section.

The following items are controlled in the vehicle-to-vehicle distance control mode:

- When there are no vehicles traveling ahead, the vehicle-to-vehicle distance control mode maintains the speed set by the driver. The set speed range is between approximately 25 and 90 MPH (40 and 144 km/h).
- When there is a vehicle traveling ahead, the vehicle-to-vehicle distance control mode adjusts the speed to maintain the distance, selected by driver, from the vehicle ahead. The adjusting speed range is between approximately 20 MPH (32 km/h) and up to the set speed.

- When the vehicle traveling ahead has moved out from its lane of travel, the vehicle-to-vehicle distance control mode accelerates and maintains vehicle speed up to the set speed.

The ICC system does not control vehicle speed or warn you when you approach stationary and slow moving vehicles. You must pay attention to vehicle operation to maintain proper distance from vehicles ahead when approaching toll gates or traffic congestion.

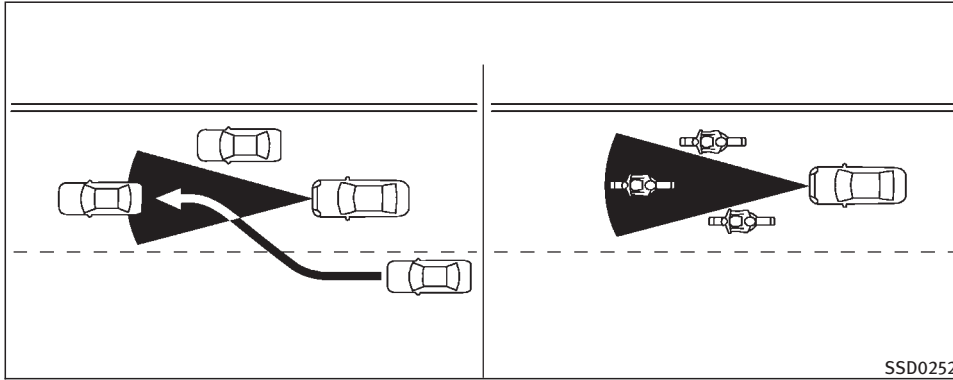

The detection zone of the ICC sensor is limited. A vehicle ahead must be in the detection zone for the vehicle-to-vehicle distance detection mode to maintain the selected distance from the vehicle ahead.

A vehicle ahead may move outside of the detection zone due to its position within the same lane of travel. Motorcycles may not be detected in the same lane ahead if they are traveling offset from the centerline of the lane. A vehicle that is entering the lane ahead may not be detected until the vehicle has completely moved into the lane. **If this occurs, the ICC system may warn you by blinking the system indicator**

**and sounding the chime. The driver may have to manually control the proper distance away from vehicle traveling ahead.**



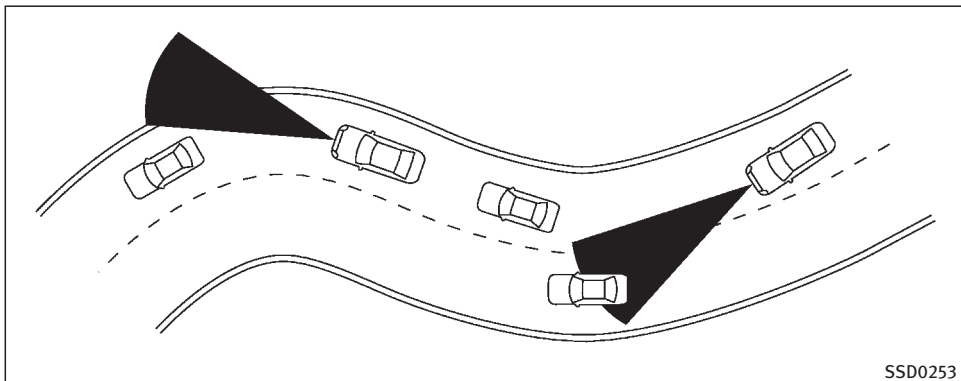

When driving on some roads, such as winding, hilly, curved, narrow roads, or roads which are under construction, the ICC sensor may detect vehicles in a different lane, or may temporarily not detect a vehicle traveling ahead. This may cause the ICC system to decelerate or accelerate the vehicle.

The detection of vehicles may also be affected by vehicle operation (steering maneuver or traveling position in the lane, etc.) or vehicle condition. **If this occurs, the ICC system may warn you by blinking the system indicator and sounding the chime unexpectedly. You will have to**

**manually control the proper distance away from the vehicle traveling ahead.**

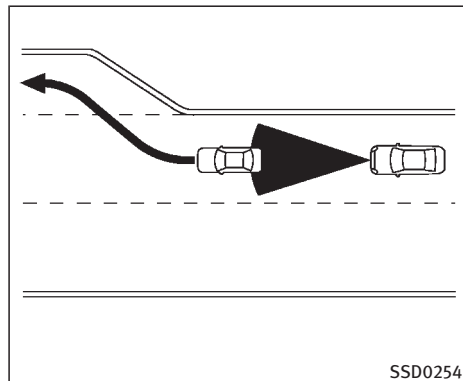

When driving on the freeway at a set speed and approaching a slower traveling vehicle ahead, the ICC will adjust the speed to maintain the distance, selected by the driver, from the vehicle ahead. If the vehicle ahead changes lanes or exits the freeway, the ICC system will accelerate and maintain the speed up to the set speed. Pay attention to the driving operation to maintain control of the vehicle as it accelerates to the set speed.

The vehicle may not maintain the set speed on winding or hilly roads. If this occurs, you will have to manually control the vehicle speed.

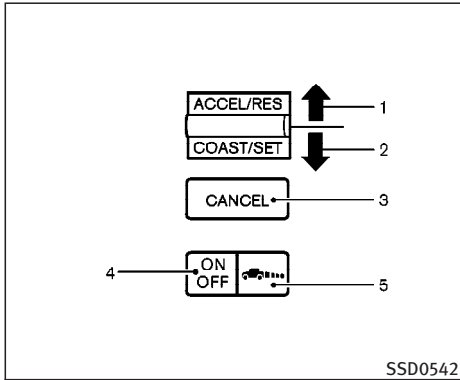

4. MAIN switch:  
Master switch to activate the system
5. DISTANCE switch:  
Changes the vehicle's following distance:
  - Long
  - Middle
  - Short

### Intelligent cruise control switch

The system is operated by a MAIN switch and four control switches, all mounted on the steering wheel.

1. RESUME/ACCELERATE switch:  
Resumes set speed or increases speed incrementally.
2. SET/COAST switch:  
Sets desired cruise speed, reduces speed incrementally.
3. CANCEL switch:  
Deactivates the system without erasing the set speed.

### 5-32 Starting and driving

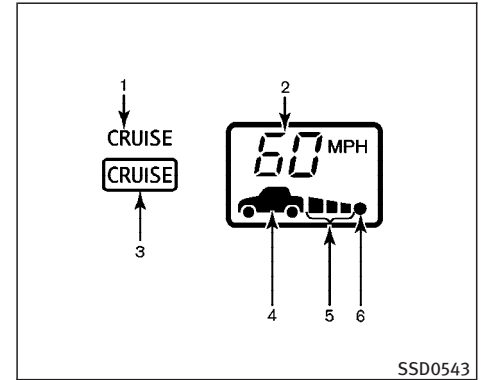

### Intelligent cruise control system display

The display is located under the tachometer.

1. Intelligent Cruise Control system warning light (Orange)  
The light comes on if there is a malfunction in the ICC system.
2. Set vehicle speed indicator  
Indicates the set vehicle speed.

For Canadian models, the speed is displayed in km/h.

3. MAIN switch indicator light (Green)  
Indicates that the MAIN switch is ON.
4. Vehicle ahead detection indicator  
Indicates whether it detects a vehicle in front of you.
5. Set distance indicator  
Displays the selected distance between vehicles set with the DISTANCE switch.
6. Indicates your vehicle

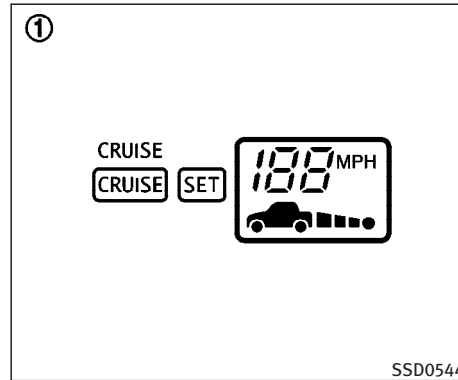

When the ignition switch is turned ON, the display ① comes on as illustrated to check for a burned-out bulb, and it turns off when the engine is started.

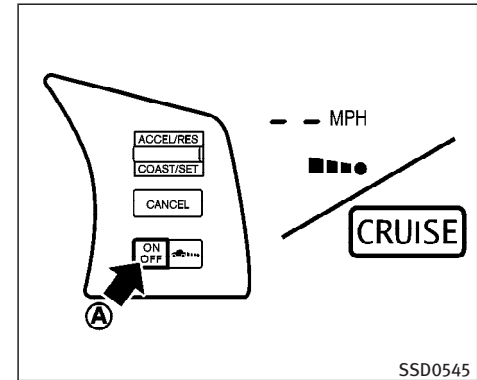

## Operating vehicle-to-vehicle distance control mode

**To turn on the cruise control**, quickly push and release the MAIN switch (A) on. The cruise indicator light, set distance indicator and set vehicle speed indicator come on and in a standby state for setting.



### CAUTION

To avoid accidentally engaging cruise control, make sure to turn the ON/OFF switch is

off when not using the Intelligent Cruise Control.

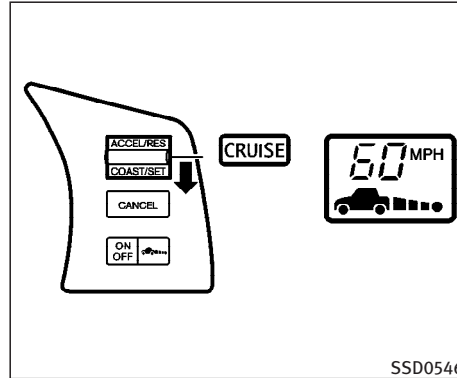

**To set cruising speed,** accelerate your vehicle to the desired speed, push the SET/COAST switch and release it. (Vehicle ahead detection indicator, set distance indicator and set vehicle speed indicator come on.) Take your foot off the accelerator pedal. Your vehicle will maintain the set speed.

The Intelligent Cruise Control system cannot be set under the following conditions even if the SET/COAST switch is pushed.

- While the brakes are applied by the driver
  - When pushing the RESUME/ACCELERATE switch without a set speed in memory
  - When the windshield wipers are operating at low speed (LO) or high speed (HI)
  - When the parking brake is applied
  - When the Vehicle Dynamic Control (VDC) system is switched off
- When traveling outside the 25 to 90 MPH (40 to 144 km/h) speed range

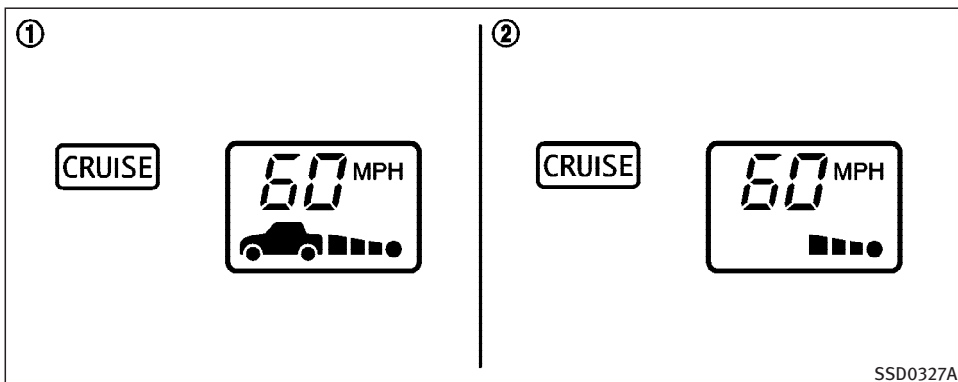

SSD0327A

1. System set display with vehicle ahead
2. System set display without vehicle ahead

## System operation



### WARNING

Normally when controlling the distance to a vehicle ahead, this system automatically accelerates or decelerates your vehicle according to the speed of the vehicle ahead. Depress the accelerator to properly accel-

erate your vehicle when acceleration is required for a lane change. Depress the brake pedal when deceleration is required to maintain a safe distance to the vehicle ahead due to its sudden braking or if a vehicle cuts in. Always stay alert when using the ICC system.

The driver sets the desired vehicle speed based on the road conditions. The ICC system maintains the set vehicle speed, similar to standard cruise control, as long as no vehicle is detected in the lane ahead.

The ICC system displays the set speed.

### Vehicle detected ahead:

When a vehicle is detected in the lane ahead, the ICC system decelerates the vehicle by controlling the throttle and applying the brakes to match the speed of a slower vehicle ahead. The system then controls the vehicle speed based on the speed of the vehicle ahead to maintain the driver selected distance.

**The stoplights of the vehicle come on and the brake pedal depresses when braking is performed by the ICC system.**



### CAUTION

Never place your foot under the brake pedal when the brake is operated by the Intelligent Cruise Control system. You may get your foot caught in the pedal.

When a vehicle ahead is detected, the vehicle ahead detection indicator comes on. The ICC system will also display the set speed and selected distance.

### Vehicle ahead not detected:

When a vehicle is no longer detected ahead, the ICC system gradually accelerates your vehicle to resume the previously set vehicle speed. The ICC system then maintains the set speed.

When a vehicle is no longer detected the vehicle ahead detection indicator turns off.

If a vehicle ahead appears during acceleration to the set vehicle speed or any time the ICC system is in operation, the system controls the distance to that vehicle.

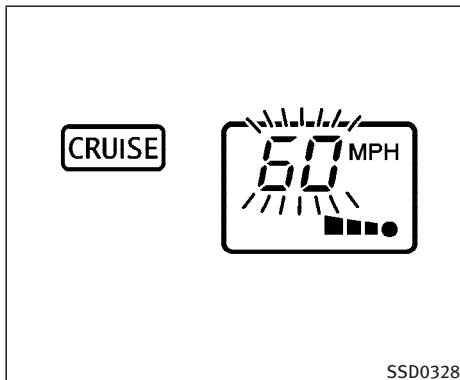

SSD0328

**When passing another vehicle,** the set speed indicator will flash when the vehicle speed exceeds the set speed. The vehicle detect indicator will turn off when the area ahead of the vehicle is open. When the pedal is released, the vehicle will return to the previously set speed.

Even though your vehicle speed is set in the ICC system, you can depress the accelerator pedal when it is necessary to accelerate your vehicle rapidly.

### How to change the set vehicle speed

**To cancel the preset speed,** use any of these methods:

- Push the CANCEL switch. The set vehicle speed indicator will go out.
- Tap the brake pedal. The set vehicle speed indicator will go out.
- Turn the MAIN switch off. Both the ON/OFF switch indicator and set vehicle speed indicator will go out.

**To reset at a faster cruising speed,** use one of the following methods:

- Depress the accelerator pedal. When the vehicle attains the desired speed, push and release the SET/COAST switch.
- Push and hold the RESUME/ACCELERATE switch. The set vehicle speed will increase by approximately 5 MPH (5 km/h for Canada).
- Push, then quickly release the RESUME/ACCELERATE switch. Each time you do this, the set speed will increase by approximately 1 MPH (1 km/h for Canada).

**To reset at a slower cruising speed,** use one of the following methods:

- Lightly tap the brake pedal. When the vehicle attains the desired speed, push the SET/COAST switch and release it.
- Push and hold the SET/COAST switch. The set vehicle speed will decrease by approximately 5 MPH (5 km/h for Canada).
- Push, then quickly release the SET/COAST switch. Each time you do this, the set speed will decrease by approximately 1 MPH (1 km/h for Canada).

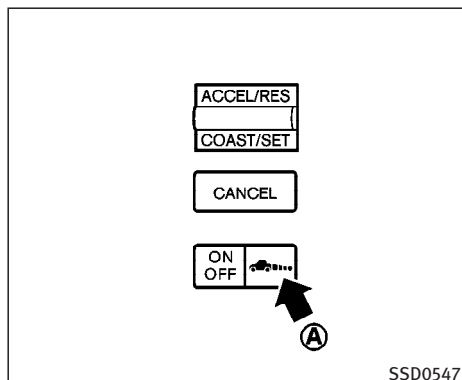

**To resume the preset speed,** push and release the RESUME/ACCELERATE switch. The vehicle will resume the last set cruising speed when the vehicle speed is over 25 MPH (40 km/h).



### How to change the set distance to the vehicle ahead

The distance to the vehicle ahead can be selected at any time depending on the traffic conditions.

Each time the DISTANCE switch (A) is pushed, the set distance will change to long, middle, short and back to long again in that sequence.

Distance	Display	Approximate distance at 60 MPH (100 km/h) [ft (m)]
Long		195 (60)
Middle		130 (40)
Short		90 (30)

SSD0329

- The distance to the vehicle ahead will change according to the vehicle speed. The higher the vehicle speed, the longer the distance.
- If the engine is stopped, the set distance becomes “long”. (Each time the

engine is started, the initial setting becomes “long”.)

### Approach warning

If your vehicle comes closer to the vehicle ahead due to rapid deceleration of that ve-

hicle or if another vehicle cuts in, the system warns the driver with the chime and ICC system display. Decelerate by depressing the brake pedal to maintain a safe vehicle distance if:

- The chime sounds.
- The vehicle ahead detection and set distance indicator blink.

The warning chime may not sound in some cases when there is a short distance between vehicles. Some examples are:

- When the vehicles are traveling at the same speed and the distance between vehicles is not changing
- When the vehicle ahead is traveling faster and the distance between vehicles is increasing
- When the accelerator pedal is depressed, overriding the system
- When a vehicle cuts in near your vehicle

The warning chime will not sound when your vehicle approaches vehicles that are parked or moving slowly.



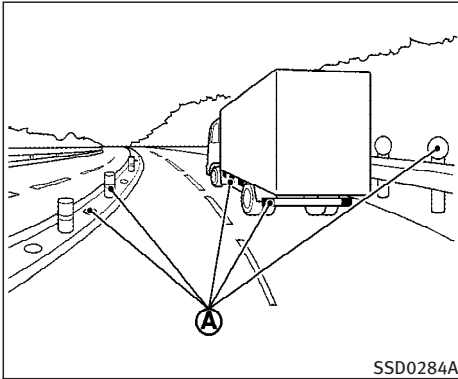

**NOTE:**

The approach warning chime may sound and the system display may blink when the ICC sensor detects some reflectors (A) which are fitted on vehicles in other lanes or on the side of the road. This may cause the ICC system to decelerate or accelerate the vehicle. The ICC sensor may detect these reflectors when the vehicle is driven on winding roads, hilly roads or when entering or exiting a curve. The ICC sensor may also detect reflectors on narrow roads or in road construction zones. In these cases you will have to manually control the proper distance ahead of your vehicle.

Also, the sensor sensitivity can be affected by vehicle operation (steering maneuver or driving position in the lane) or traffic or vehicle condition (for example, if a vehicle is being driven with some damage).

**Automatic cancellation**

A chime sounds under the following conditions and the control is automatically canceled.

- When the vehicle speed falls below approximately 20 MPH (32 km/h)
- When the selector lever is shifted to the N (Neutral) position
- When the windshield wipers are operated at low speed (LO) or high speed (HI)
- When the parking brake is applied
- When the VDC is turned off
- When the VDC operates

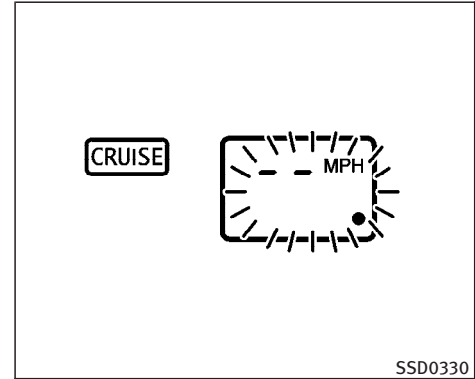

**Warning light and display**

**Condition A**

The chime sounds and the Intelligent Cruise Control system is canceled automatically in the conditions described below. Part of the system display will come on or blink, making it impossible to set.

- When the VDC is turned off
- When the VDC operates
- When a tire slips

- When strong light (sunlight, etc.) is directly shining on the front of the vehicle

**Action to take:**

When the conditions listed above are no longer present, turn the system off using the Intelligent Cruise Control MAIN Switch. Turn the ICC system back on to use the system.

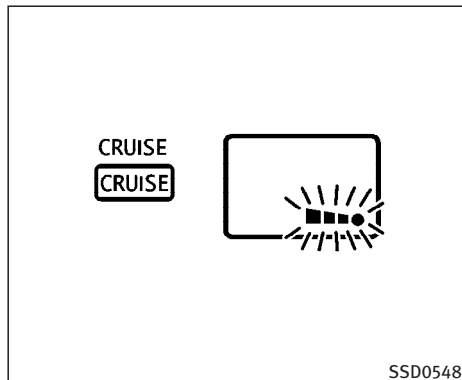

**Condition B**

When the sensor window is dirty, making it impossible to detect a vehicle ahead, the ICC system is automatically canceled.

The chime sounds and the system warning light (Orange) will come on and the set distance indicators will blink.

**Action to take:**

If the warning light comes on, park the vehicle in a safe place, turn the engine off. Clean the sensor window with a soft cloth and then perform the settings again.

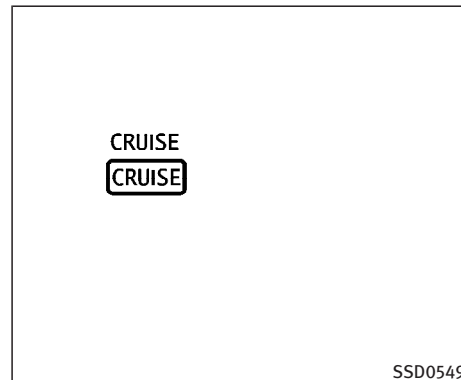

**Condition C**

When the ICC system is not operating properly, the chime sounds and the system warning light (Orange) will come on.

**Action to take:**

If the warning light comes on, park the vehicle in a safe place. Turn the engine off, restart the engine, resume driving and set the ICC system again.

**If it is not possible to set the system or the indicator stays on, it may indicate that the system is malfunctioning. Although the ve-**

hicle is still driveable under normal conditions, have the vehicle checked at an INFINITI dealer.

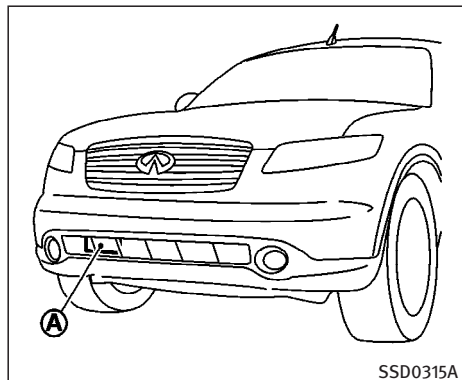

### Sensor maintenance

The sensor for the ICC system (A) is located below the front bumper.

To keep the ICC system operating properly, be sure to observe the following:

- Always keep the sensor clean. Wipe with a soft cloth carefully so as not to damage the sensor.
- Do not strike or damage the areas around the sensor. Do not touch or remove the screw located on the sensor. Doing so could cause a failure or malfunction. If the sensor is damaged due

to an accident, contact an INFINITI dealer.

- Do not attach a sticker (including transparent material) or install an accessory near the sensor. This could cause a failure or malfunction.

### CONVENTIONAL (FIXED SPEED) CRUISE CONTROL MODE

This mode allows driving at a speed between 25 to 90 MPH (40 to 144 km/h) without keeping your foot on the accelerator pedal.



### WARNING

- In the conventional (fixed speed) cruise control mode, a warning chime does not sound to warn you if you are too close to the vehicle ahead, as neither the presence of the vehicle ahead nor the vehicle-to-vehicle distance is detected.
- Pay special attention to the distance between your vehicle and the vehicle ahead of you or a collision could occur.

- Always confirm the setting in the Intelligent Cruise Control system display.
- Do not use the conventional (fixed speed) cruise control mode when driving under the following conditions:
  - when it is not possible to keep the vehicle at a set speed
  - in heavy traffic or in traffic that varies in speed
  - on winding or hilly roads
  - on slippery roads (rain, snow, ice, etc.)
  - in very windy area.
- Doing so could cause a loss of vehicle control and result in an accident.

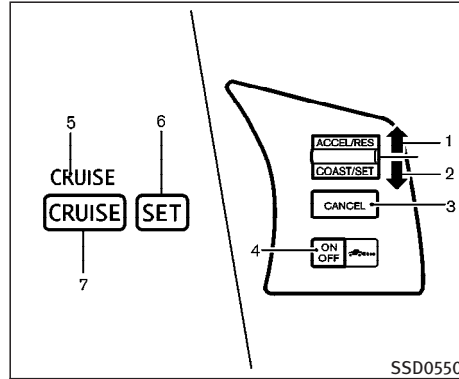

### Conventional (fixed speed) cruise control mode display and switch

The display is located under the tachometer.

1. RESUME/ACCELERATE switch:  
Resumes set speed or increases speed incrementally.
2. SET/COAST switch:  
Sets the desired cruise speed, reduces speed incrementally.
3. CANCEL switch:  
Deactivates the system without erasing the set speed.

4. MAIN switch:  
Master switch to activate the system
5. MAIN switch indicator light:  
Indicates that the MAIN switch is ON.
6. Cruise set switch indicator light:  
The light comes on while the vehicle speed is controlled by the conventional (fixed speed) cruise control mode of the ICC system.
7. Intelligent cruise control system warning light:  
The light comes on if there is a malfunction in the cruise control system.

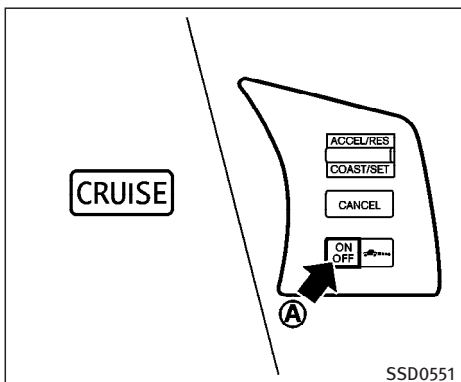

## Operating conventional (fixed speed) cruise control mode

**To turn on the conventional (fixed speed) cruise control mode**, push and hold the MAIN switch **A** for longer than about 1.5 seconds.

When pushing the MAIN switch on, the Intelligent Cruise Control system display and the CRUISE indicator light (Green) in the instrument cluster come on. After you hold the MAIN switch on for longer than about 1.5 seconds, the Intelligent Cruise Control system display goes out. The CRUISE indicator stays lit. You can now set your de-

sired cruising speed. Pushing the MAIN switch again will turn the system completely off.

When the ignition switch is turned off, the system is also automatically turned off. To use the Intelligent Cruise Control again, quickly push and release the MAIN switch (vehicle-to-vehicle distance control mode) or push and hold it (conventional cruise control mode) again to turn it on.



## CAUTION

**To avoid accidentally engaging cruise control, make sure to turn the ON/OFF switch off when not using the Intelligent Cruise Control.**

**To set cruising speed**, accelerate your vehicle to the desired speed, push the SET/COAST switch and release it. (The SET indicator light will come on.) Take your foot off the accelerator pedal. Your vehicle will maintain the set speed.

- **To pass another vehicle**, depress the accelerator pedal. When you release the pedal, the vehicle will return to the previously set speed.

- The vehicle may not maintain the set speed when going up or down steep hills. If this happens, manually maintain vehicle speed.

**To cancel the preset speed**, use any of the following methods:

- Push the CANCEL button. The SET indicator light will go out.
- Tap the brake pedal. The SET indicator light will go out.
- Turn the MAIN switch off. Both the CRUISE indicator and SET indicator lights will go out.

**To reset at a faster cruising speed**, use one of the following three methods:

- Depress the accelerator pedal. When the vehicle attains the desired speed, push and release the SET/COAST switch.
- Push and hold the RESUME/ACCELERATE set switch. When the vehicle attains the speed you desire, release the switch.
- Push, then quickly release the RESUME/ACCELERATE switch. Each time you do this, the set speed will increase by about 1 MPH (1.6 km/h).

**To reset at a slower cruising speed**, use one of the following three methods:

- a) Lightly tap the brake pedal. When the vehicle attains the desired speed, push the SET/COAST switch and release it.
- b) Push and hold the SET/COAST switch. Release the switch when the vehicle slows down to the desired speed.
- c) Push, then quickly release the SET/COAST switch. Each time you do this, the set speed will decrease by about 1 MPH (1.6 km/h).

**To resume the preset speed**, push and release the RESUME/ACCELERATE switch. The vehicle will resume the last set cruising speed when the vehicle speed is over 25 MPH (40 km/h).

### Automatic cancellation

A chime sounds under the following conditions and the control is automatically canceled.

- When the vehicle slows down more than 8 MPH (13 km/h) below the set speed
- When the vehicle speed falls below approximately 20 MPH (32 km/h)

### 5-44 Starting and driving

- When the selector lever is shifted to the N (Neutral) position
- When the parking brake is applied
- When the VDC operates (except ABS, which is functional with ICC system operation)

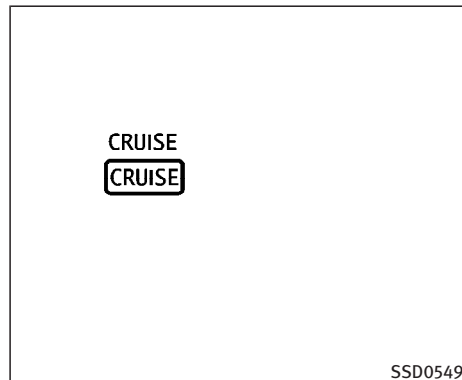

### Warning light

When the system is not operating properly, the chime sounds and the system warning light (Orange) will come on.

#### Action to take:

If the warning light comes on, park the vehicle in a safe place. Turn the engine off, restart the engine, resume driving and then perform the setting again.

**If it is not possible to set or the indicator stays on, it may indicate that the system is malfunctioning. Although the vehicle is still driveable under normal conditions,**

have the vehicle checked at an INFINITI dealer.

### PREVIEW FUNCTION (for Intelligent Cruise Control system equipped models)

The ICC system with the preview function identifies the need to apply emergency braking by sensing the vehicle ahead in the same lane and the distance to the vehicle ahead and relative speed from it, it applies the brake pre-pressure before the driver depresses the brake pedal and helps improve brake response by reducing pedal free play.

For more details, refer to “Brake assist (with preview function)” later in this section.

## BREAK-IN SCHEDULE



### CAUTION

**During the first 1,200 miles (2,000 km), follow these recommendations to obtain maximum engine performance and ensure the future reliability and economy of your new vehicle. Failure to follow these recommendations may result in shortened engine life and reduced engine performance.**

- Avoid driving for long periods at constant speed, either fast or slow. Do not run the engine over 4,000 rpm.
- Do not accelerate at full throttle in any gear.
- Avoid quick starts.
- Avoid hard braking as much as possible.
- Do not tow a trailer for the first 500 miles (805 km).

## INCREASING FUEL ECONOMY



- Accelerate slowly and smoothly. Maintain cruising speeds with a constant accelerator position.
- Drive at moderate speeds on the highway. Driving at high speed will lower fuel economy.
- Avoid unnecessary stopping and braking. Maintain a safe distance behind other vehicles.
- Use a proper gear range which suits road conditions. On level roads, shift into high gear as soon as possible.
- Avoid unnecessary engine idling.
- Keep your engine tuned up.
- Follow the recommended periodic maintenance schedule.
- Keep the tires inflated at the correct pressure. Low pressure will increase tire wear and waste fuel.
- Keep the front wheels in correct alignment. Improper alignment will cause not only tire wear but also lower fuel economy.
- Air conditioner operation lowers fuel economy. Use the air conditioner only when necessary.

## ALL-WHEEL DRIVE (AWD) (if so equipped)

- When cruising at highway speeds, it is more economical to use the air conditioner and leave the windows closed to reduce drag.

Your vehicle is equipped with full-time All-Wheel Drive (AWD).

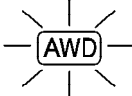
Switching the driving mode is not necessary.

Warning light	Comes on or blinks when
 Comes on	There is a malfunction in the all-wheel drive system.
 Blinks rapidly	The power-train oil temperature rises extremely high.
 Blinks slowly	The difference in wheel rotation is large.

SSD0314B

The AWD warning light is located in the meter.

The AWD warning light comes on when the key switch is turned to ON. It turns off soon after the engine is started.



If any malfunction occurs in the AWD system, the warning light comes on while engine is running.

The warning light may blink rapidly (about twice per second) while trying to free a stuck vehicle due to high power train oil temperature. The driving mode may change to 2 wheel drive. If the warning light blinks rapidly, stop the vehicle with the engine idling in a safe place immediately. Then if the light goes off after a while, you can continue driving.

A large difference between the diameters of front and rear wheels will make the warning light blink slowly (about once per two seconds). Pull off the road in a safe area, and idle the engine. Check that all tire sizes are the same, tire pressure is correct and tires are not worn.

If the warning light is blinking after the above operation, have your vehicle checked by an INFINITI dealer as soon as possible.



## CAUTION

- Do not place an AWD equipped vehicle on a two wheel dynamometer or raise two wheels off the ground and shift the transmission to any D (drive) or R (reverse) position. Doing so may result in transmission damage or unexpected vehicle movement which could result in serious vehicle damage or personal injury.
  - Do not attempt to test an AWD equipped vehicle with two wheels on a two wheel dynamometer and the other two wheels raised. Doing so may result in transmission damage or unexpected vehicle movement which could result in serious vehicle damage or personal injury.
  - If the warning light comes on while driving, there may be a malfunction in the AWD system. Reduce the vehicle speed and have your vehicle checked by an INFINITI dealer as soon as possible.
- If the warning light is still on after the above operation, have your vehicle checked by an INFINITI dealer as soon as possible.
  - The power train may be damaged if you continue driving with the warning light blinking rapidly.

## PARKING/PARKING ON HILLS

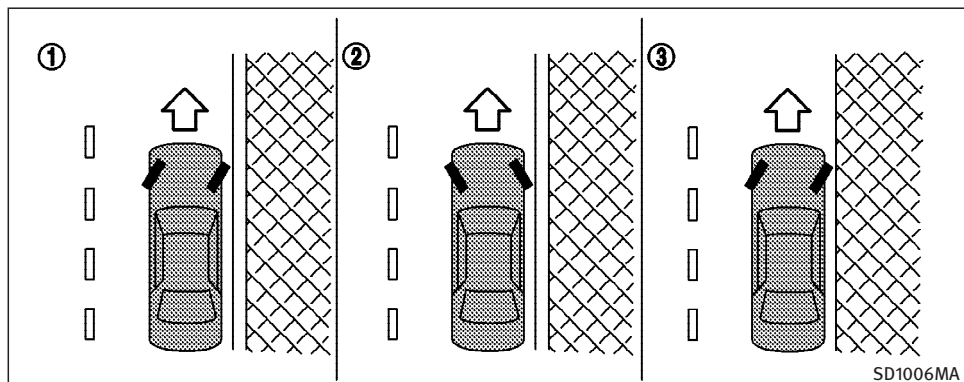

### WARNING

- Do not stop or park the vehicle over flammable materials such as dry grass, waste paper or rags. They may ignite and cause a fire.
- Never leave the engine running while the vehicle is unattended.
- Never leave children unattended in the vehicle.

- Safe parking procedures require that both the parking brake be set and the transmission placed into P (Park) for automatic transmission models. Failure to do so could cause the vehicle to move unexpectedly or roll away and result in an accident.

- Make sure the automatic transmission selector lever has been pushed as far forward as it can go and cannot be moved without depressing the button at the end of the lever.

1. Firmly apply the parking brake.
  2. Move the selector lever to the P (Park) position.
  3. To help prevent the vehicle from rolling into the street when parked on a sloping drive way, it is a good practice to turn the wheels as illustrated.
- HEADED DOWNHILL WITH CURB: ①  
Turn the wheels into the curb and move the vehicle forward until the curb side wheel gently touches the curb.
  - HEADED UPHILL WITH CURB: ②  
Turn the wheels away from the curb and move the vehicle back until the curb side wheel gently touches the curb.

- HEADED UPHILL OR DOWNHILL, NO CURB: ③

Turn the wheels toward the side of the road so the vehicle will move away from the center of the road if it moves.

4. Turn the ignition switch to the LOCK position and remove the key (if a metal key is used).

## POWER STEERING

The power assisted steering is designed to use a hydraulic pump, driven by the engine, to assist steering.

If the engine stops or the drive belt breaks, you will still have control of the vehicle. However, much greater steering effort is needed, especially in sharp turns or at low speeds.



### WARNING

**If the engine is not running or is turned off while driving, the power assist for the steering will not work. Steering will be much harder to operate.**

## BRAKE SYSTEM

### BRAKING PRECAUTIONS

The brake system has two separate hydraulic circuits. If one circuit malfunctions, you will still have braking at two wheels.

#### Vacuum assisted brake

The brake booster aids braking by using engine vacuum. If the engine stops, you can stop the vehicle by depressing the brake pedal. However, greater foot pressure on the brake pedal will be required to stop the vehicle and the stopping distance will be longer.

#### Wet brakes

When the vehicle is washed or driven through water, the brakes may get wet. As a result, your braking distance will be longer and the vehicle may pull to one side during braking.

To dry brakes, drive the vehicle at a safe speed while lightly pressing the brake pedal to heat-up the brakes. Do this until the brakes return to normal. Avoid driving the vehicle at high speeds until the brakes function correctly.

### Parking brake break-in

Break-in the parking brake shoes whenever the stopping effect of the parking brake is weakened or whenever the parking brake shoes and/or drums/rotors are replaced, in order to assure the best braking performance.

This procedure is described in the vehicle Service Manual and can be performed by an INFINITI dealer.

### Using the brakes

Avoid resting your foot on the brake pedal while driving. This overheats the brakes, increases wear on the brakes and pads, and reduces gas mileage.

To help save the brakes and to prevent the brakes from overheating, reduce speed and downshift to a lower gear before going down a slope or long grade. Overheated brakes may reduce braking performance and could result in loss of vehicle control.



### WARNING

- **While driving on a slippery surface, be careful when braking, accelerating or downshifting. Abrupt braking or accelerating could cause the wheels to skid and result in an accident.**
- **If the engine is not running or is turned off while driving, the power assist for the brakes will not work. Braking will be harder.**

## BRAKE ASSIST

### BRAKE ASSIST

When the force applied to the brake pedal exceeds a certain level, the Brake Assist is activated generating a greater braking force than a conventional brake booster even with light pedal force.



### WARNING

**The Brake Assist is only an aid to assist braking operation and is not a collision warning or avoidance device. It is the driver's responsibility to stay alert, drive safely and be in control of the vehicle at all times.**

### BRAKE ASSIST (WITH PREVIEW FUNCTION) (Intelligent Cruise Control system equipped model)

In addition to the brake assist, vehicles equipped with the Intelligent Cruise Control system have a preview function.

When the Preview Function identifies the need to apply emergency braking by sensing a vehicle ahead in the same lane and the distance and relative speed from it, it applies the brake pre-pressure before the driver depresses the brake pedal and helps

improve brake response by reducing pedal free play.

- This system will not operate when the vehicle is moving at approximately 20 MPH (32 km/h) or less.
- The pre-pressure function ceases when the following conditions are met:
  - a) When the driver depresses the accelerator pedal or the brake pedal.
  - b) If the driver does not operate the accelerator or brake pedal within approximately 1 second.

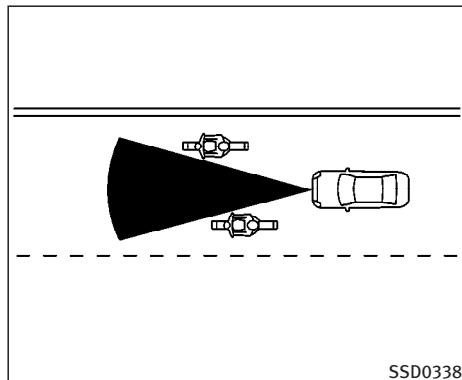

- The sensor will not detect:
  - a) Pedestrians or objects in the roadway
  - b) Oncoming vehicles in the same lane
  - c) Motorcycles or scooters traveling offset in the travel lane as illustrated



## WARNING

- The Preview Function is only an aid to assist the driver and is not a collision warning or avoidance device. Although the

brake operation is controlled by the system, it does not automatically decelerate the vehicle speed.

It is the driver's responsibility to stay alert, drive safely and be in control of the vehicle at all times.

- As there is a performance limit to the Preview Function, never rely solely on this system. This system does not correct careless, inattentive or absent-minded driving, or overcome poor visibility in rain, fog, or other bad weather. Reduce vehicle speed by depressing the brake pedal, in order to maintain a safe distance between vehicles.
- The system may not detect the vehicle in front of you in certain road or weather conditions. The Preview Function may not operate properly under the following conditions. The vehicle is still drivable under normal conditions and the Brake Assist will operate.
  - When rain, snow or dirt adhere to the system sensor.

- When strong light (for example, at sunrise or sunset) is directly shining on the front of the vehicle.
- Winding or hilly roads may cause the sensor to temporarily not detect a vehicle in the same lane or may detect objects or vehicles in other lanes.
- Vehicle position in the lane may cause the sensor to temporarily not detect a vehicle in the same lane or may detect objects or vehicles in other lanes.
- When the Preview Function operates, the brake pedal may move slightly and may make a small noise. This is not a system malfunction.

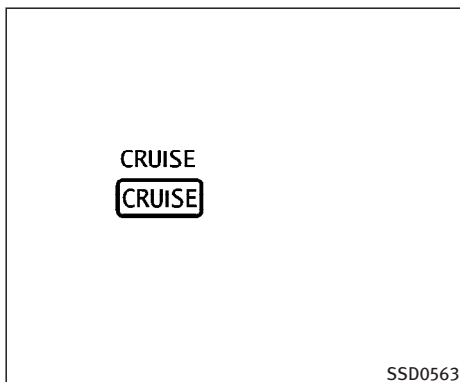

### Warning light and display

When the Preview Function is not operating properly, the buzzer sounds and the system warning light (Orange) will come on.

#### Action to take:

If the warning light comes on, park the vehicle in a safe place. Turn the engine off, restart the engine and resume driving.

**If the indicator stays on, it may indicate that the Preview Function is malfunctioning (the brake is operative). Although the Vehicle is still driveable under normal**

**conditions, have the vehicle checked at an INFINITI dealer.**

### How to handle the sensor

The sensor for the Preview Function is common with Intelligent Cruise Control and is located below the front bumper.

To keep the Preview Function operating properly, be sure to observe the following:

- Always keep the sensor clean. Wipe with a soft cloth carefully so as not to damage them.
- Do not impact the areas around the sensor. Do not touch or disassemble the screw located on the sensor. Doing so could cause failure or malfunction. If the sensor installation part is deformed due to an accident, contact an INFINITI dealer.
- Do not attach a sticker (including transparent material) or install an accessory near the sensor. This could cause failure or malfunction.

### ANTI-LOCK BRAKE SYSTEM (ABS)

The anti-lock brake system controls the brakes so the wheels will not lock when

braking abruptly or when braking on slippery surfaces. The system detects the rotation speed at each wheel and varies the brake fluid pressure to prevent each wheel from locking and sliding. By preventing wheel lockup, the system helps the driver maintain steering control and helps to minimize swerving and spinning on slippery surfaces.

### Using the system

Depress the brake pedal and hold it down.



### WARNING

**Do not pump the brake pedal. Doing so may result in increased stopping distances.**

### Normal operation

The anti-lock brake system will not operate at speeds below 3 to 6 MPH (5 to 10 km/h) to completely stop the vehicle. (The speeds will vary according to road conditions.) When the anti-lock system senses that one or more wheels are close to locking up, the actuator (under the hood) rapidly applies and releases hydraulic pressure (like pumping the brakes very quickly). While the actuator is working, you may feel a pul-

sation in the brake pedal and hear a noise or vibration from the actuator under the hood. This is normal and indicates that the anti-lock system is working properly. However, the pulsation may indicate that road conditions are hazardous and extra care is required while driving.

### Self-test feature

The anti-lock brake system consists of electronic sensors, electric pumps and hydraulic solenoids controlled by a computer. The computer has a built-in diagnostic feature that tests the system each time you start the engine and move the vehicle at a low speed in forward or reverse. When the self-test occurs, you may hear a “clunk” noise and/or feel a pulsation in the brake pedal. This is normal and is not an indication of any malfunction. If the computer senses any malfunction, it switches the anti-lock brake system off and turns on the ABS warning light on the instrument panel. The brake system then operates normally, but without anti-lock assistance.

If the light comes on during the self-test, or while driving, take your vehicle to an INFINITI dealer for repair.



### WARNING

**The anti-lock brake system is a sophisticated device, but it cannot prevent accidents resulting from careless or dangerous driving techniques. It can help maintain vehicle control during braking on slippery surfaces, but remember that the stopping distance on slippery surfaces will be longer than on normal surfaces, even with the anti-lock brake system. Stopping distances may also be longer on rough, gravel or snow covered roads, or if you are using tire chains. Always maintain a safe distance from the vehicle in front of you. Ultimately, the responsibility for safety of yourself and others rests in the hands of the driver.**

**Tire type and condition of tires may also affect braking effectiveness.**

- **When replacing tires, install the specified size of tires on all four wheels.**
- **When installing a spare tire, make sure it is the proper size and type as specified**

on the Tire and Loading Information label. See “Vehicle identification” in the “9. Technical and consumer information” section.

## VEHICLE DYNAMIC CONTROL (VDC) SYSTEM

When accelerating or driving on a slippery surface, the tires may spin or slide. With the Vehicle Dynamic Control (VDC) system, sensors detect these movements and control the braking and engine output to help improve vehicle stability.

- When the VDC system is operating, the “SLIP” indicator in the instrument panel blinks.
- When only the Traction Control System (TCS) portion of the VDC system is operating, the “SLIP” indicator in the instrument panel blinks.
- If the “SLIP” indicator blinks, the road conditions are slippery. Be sure to adjust your speed and driving to these conditions. Be sure to drive carefully. See “Slip indicator light”, and “Vehicle Dynamic Control (VDC) off indicator light” in the “2. Instruments and controls” section.
- Indicator light  
If a malfunction occurs in the system, the “SLIP” and “VDC OFF” indicator lights illuminate in the instrument panel. As long as these indicators are illuminated, the VDC system function is canceled.

The VDC system uses an Active Brake Limited Slip (ABLS) system to improve vehicle traction. The ABLS system works when one of the driving wheels is spinning on a slippery surface. The ABLS system brakes the spinning wheel which distributes the driving power to the other driving wheel. If the vehicle is operated with the VDC system turned off, all VDC system functions and TCS functions will be turned off. The ABLS system and ABS will still operate with the VDC system off. When the ABLS system is activated, the “SLIP” indicator light will blink and you may hear a clunk noise and/or feel a pulsation in the brake pedal. This is normal and is not an indication of a malfunction.

While the VDC system is operating, you may feel a pulsation in the brake pedal and hear a noise or feel a vibration from under the hood. This is normal and indicates that the VDC system is working properly.

The VDC system computer has a built in diagnostic feature that tests the system each time you start the engine and move the vehicle forward or backward. When the self-test occurs, you may hear a clunk noise and/or feel a pulsation in the brake pedal. This is normal and is not an indication of a malfunction.





## WARNING

- The VDC system is designed to help improve driving stability but does not prevent accidents due to abrupt steering operation at high speeds or due to careless or dangerous driving. Reduce vehicle speed and be especially careful when driving and cornering on slippery surfaces and always drive carefully.
  - If engine related parts such as muffler are not standard equipment or are extremely deteriorated, the “VDC OFF” indicator or “SLIP” indicator or both indicator lights may illuminate.
  - Do not modify the vehicle’s suspension. If suspension parts such as shock absorbers, struts, springs, stabilizer bars and bushings are not INFINITI-approved or are extremely deteriorated, the VDC system may not operate properly. This could adversely affect vehicle handling performance, and the “VDC OFF” indicator or “SLIP” indicator or both indicator lights may illuminate.
- If brake related parts such as brake pads, rotors and calipers are not standard equipment or are extremely deteriorated, the “VDC OFF” indicator or “SLIP” indicator or both indicator lights may illuminate.
  - When driving on extremely inclined surfaces such as higher banked corners, the Vehicle Dynamic Control system may not operate properly and the “VDC OFF” indicator or “SLIP” indicator or both indicator lights may illuminate. Do not drive on these types of roads.
  - When driving on an unstable surface such as a turntable, ferry, elevator or ramp, the “VDC OFF” indicator or “SLIP” indicator or both indicator lights may illuminate. This is not a malfunction. Restart the engine after driving onto a stable surface.
  - If wheels or tires other than those recommended are used, the VDC system may not operate properly and the “VDC OFF” indicator or “SLIP” indicator or both indicator lights may illuminate.
- The VDC system is not a substitute for winter tires or tire chains on a snow covered road.

## COLD WEATHER DRIVING

### FREEING A FROZEN DOOR LOCK

To prevent a door lock from freezing, apply deicer or glycerin to it through the key hole. If the lock becomes frozen, heat the key before inserting it into the key hole.

### ANTI-FREEZE

In the winter when it is anticipated that the temperature will drop below 32°F (0°C), check anti-freeze to assure proper winter protection. For additional information, see “Engine cooling system” in the “8. Maintenance and do-it-yourself” section.

### BATTERY

If the battery is not fully charged during extremely cold weather conditions, the battery fluid may freeze and damage the battery. To maintain maximum efficiency, the battery should be checked regularly. For additional information, see “Battery” in the “8. Maintenance and do-it-yourself” section.

### DRAINING OF COOLANT WATER

If the vehicle is to be left outside without anti-freeze, drain the cooling system by opening the drain plug located under the radiator. Refill before operating the vehicle. See “Engine cooling system” in the

### 5-56 Starting and driving

“8. Maintenance and do-it-yourself” section for changing engine coolant.

### TIRE EQUIPMENT

1. **SUMMER** tires are of a tread design to provide superior performance on dry pavement. However, the performance of these tires will be substantially reduced in snowy and icy conditions. If you operate your vehicle on snowy or icy roads, INFINITI recommends the use of **MUD & SNOW** or **ALL SEASON** tires on all four wheels. Please consult an INFINITI dealer for the tire type, size, speed rating and availability information.

2. For additional traction on icy roads, studded tires may be used. However, some provinces and states prohibit their use. Check local, state and provincial laws before installing studded tires.

**Skid and traction capabilities of studded snow tires, on wet or dry surfaces, may be poorer than that of non-studded snow tires.**

3. Tire chains may be used if desired. Make sure they are of proper size for the tires on your vehicle and are installed according to the chain manufacturer’s suggestions. Use of tire chains may be prohibited according to location. Check the local laws before installing tire chains. When installing tire chains, make sure they are of proper size for the tires on your vehicle and are installed according to the chain manufacturer’s suggestions. **Use only SAE Class S chains.** Class “S” chains are used on vehicles with restricted tire to vehicle clearance. Vehicles that can use Class “S” chains are designed to meet the SAE standard minimum clearances between the tire and the closest vehicle suspension or body component required to accommodate the use of a winter traction device (tire chains or cables). The minimum clearances are determined using the factory equipped tire size. Other types may damage your vehicle. Use chain tensioners when recommended by the tire chain manufacturer to ensure a tight fit. Loose end links of the tire chain must be secured or removed to prevent the possibility of whipping action damage to the fenders or underbody. If possible, avoid fully

loading your vehicle when using tire chains. In addition, drive at a reduced speed. Otherwise, your vehicle may be damaged and/or vehicle handling and performance may be adversely affected.

- **Never install tire chains on TEMPORARY USE ONLY spare tires.**
- **Do not use tire chains on dry roads.**
- **Tire chains must be installed only on the rear wheels and not on the front wheels.**

Do not drive with tire chains on paved roads which are clear of snow. Driving with chains in such conditions can cause damage to the various mechanisms of the vehicle due to some over-stress.

4. For all wheel drive:  
If you install snow tires, they must also be the same size, brand, construction and tread pattern on all four wheels.

## SPECIAL WINTER EQUIPMENT

It is recommended that the following items be carried in the vehicle during winter:

- a scraper and stiff-bristled brush to remove ice and snow from the windows and wiper blades.
- a sturdy, flat board to be placed under the jack to give it firm support.
- a shovel to dig the vehicle out of snow-drifts.
- extra window washer fluid to refill the reservoir tank.

## DRIVING ON SNOW OR ICE



### WARNING

- **Wet ice (32°F, 0°C and freezing rain), very cold snow or ice can be slick and very hard to drive on. The vehicle will have much less traction or “grip” under these conditions. Try to avoid driving on wet ice until the road is salted or sanded.**
- **Whatever the condition, drive with caution. Accelerate and slow down with care. If accelerating or downshifting too fast, the drive wheels will lose even more traction.**

- **Allow more stopping distance under these conditions. Braking should be started sooner than on dry pavement.**
- **Allow greater following distances on slippery roads.**
- **Watch for slippery spots (glare ice). These may appear on an otherwise clear road in shaded areas. If a patch of ice is seen ahead, brake before reaching it. Try not to brake while on the ice, and avoid any sudden steering maneuvers.**
- **Do not use cruise control on slippery roads.**
- **Snow can trap dangerous exhaust gases under your vehicle. Keep snow clear of the exhaust pipe and from around your vehicle.**

## ENGINE BLOCK HEATER (if so equipped)

An engine block heater to assist extreme cold temperature starting is available through an INFINITI dealer.



## **WARNING**

**Do not use your heater with an ungrounded electrical system or two-pronged (cheater) adapters. You can be injured by an electrical shock if you use an ungrounded connection.**

# 6 In case of emergency

Roadside assistance program.....	6-2	Push starting .....	6-12
Flat tire .....	6-2	If your vehicle overheats .....	6-13
Tire pressure monitoring system (TPMS).....	6-2	Towing your vehicle .....	6-14
Run-flat tires (if so equipped) .....	6-3	Towing recommended by INFINITI .....	6-15
Changing a flat tire .....	6-4	Vehicle recovery	
Jump starting .....	6-10	(Freeing a stuck vehicle).....	6-16



## ROADSIDE ASSISTANCE PROGRAM

Every new INFINITI comes with a 4 year, unlimited mileage Roadside Assistance plan. In the event of a roadside emergency, Roadside Assistance Service is available to you. Please refer to your INFINITI Warranty Information Booklet for details. Both the Warranty Booklet and Roadside Assistance Calling Card in your Owner's Literature Portfolio provide the Toll-Free Number to call for assistance. Roadside Assistance is provided 24 hours a day, 365 days a year, for 4 years from the date sold to give emergency roadside help, in the event of mechanical or nonmechanical trouble(s) such as flat tires, out-of-gas, dead battery, lost keys, mechanical breakdown, accident, etc.

### 6-2 In case of emergency

## FLAT TIRE

For vehicles equipped with run-flat tires, the vehicle can be driven for a limited time on a flat tire, see "Run-flat tires (if so equipped)" in the "8. Maintenance and do-it-yourself" section.

## TIRE PRESSURE MONITORING SYSTEM (TPMS)

This vehicle is equipped with the tire pressure monitoring system (TPMS). It monitors tire pressure of all tires except the spare. When the low tire pressure warning light is lit or flashing continuously, one or more of your tires is significantly under-inflated. If equipped, the system also displays pressure of all tires (except the spare tire) on the display screen by sending a signal from a sensor that is installed in each wheel. If the vehicle is being driven with low tire pressure, the TPMS will activate and warn you of it by the low tire pressure warning light. This system will activate only when the vehicle is driven at speeds above 16 MPH (25 km/h). For more details, please refer to "Warning/indicator lights and audible reminders" in the "2. Instruments and controls" section, "Tire pressure information" in the "4. Display screen, heater, air conditioner and audio systems" section and "Tire pressure moni-

toring system (TPMS)" in the "5. Starting and driving" section.



## WARNING

- If the low tire pressure warning light illuminates while driving, avoid sudden steering maneuvers or abrupt braking, reduce vehicle speed, pull off the road to a safe location and stop the vehicle as soon as possible. Serious vehicle damage could occur and may lead to an accident and could result in serious personal injury. Check the tire pressure for all four tires. Adjust the tire pressure to the recommended COLD tire pressure shown on the Tire and Loading Information label to turn the low tire pressure warning light OFF. If you have a flat tire, replace it with a spare tire as soon as possible.
- Although you can continue driving with a punctured run-flat tire (if so equipped), remember that vehicle handling stability is reduced, which could lead to an accident and personal injury. Also, driving along distance at high speeds may damage the tires.

- Do not drive at speeds above 55 MPH (88 km/h) and do not drive more than 50 miles (80 km) with a punctured run-flat tire (if so equipped). The actual distance the vehicle can be driven on a flat tire depends on outside temperature, vehicle load, road conditions and other factors.
- Do not tow a trailer when a run-flat (if so equipped) tire is flat.
- When a spare tire is mounted or a wheel is replaced, tire pressure will not be indicated, the TPMS will not function and the low tire pressure warning light will flash. Contact your INFINITI dealer as soon as possible for tire replacement and/or system resetting.
- Replacing tires with those not originally specified by INFINITI could affect the proper operation of the TPMS.
- Do not inject any tire liquid or aerosol tire sealant into the tires, as this may cause a malfunction of the tire pressure sensors.

## RUN-FLAT TIRES (if so equipped)

Run-flat tires are those tires that can be used temporarily if they are punctured. After driving to a safe location, replace the punctured run-flat tire, following the instructions later in “Changing a flat tire”. For additional information, see “Wheels and tires” in the “8. Maintenance and do-it-yourself” section. Also, see the tire safety information in the INFINITI Warranty Information Booklet.



### WARNING

- Although you can continue driving with a punctured run-flat tire, remember that vehicle handling stability is reduced, which could lead to an accident and personal injury. Also, driving a long distance at high speeds may damage the tires.
- Do not drive at speeds above 55 MPH (88 km/h) and do not drive more than 50 miles (80 km) with a punctured run-flat tire (if so equipped). The actual distance the vehicle can be driven on a flat tire depends on outside temperature, vehicle load, road conditions and other factors.

- Drive safely at reduced speeds. Avoid hard cornering or braking, which may cause you to lose control of the vehicle.
- Do not tow a trailer when a run-flat tire (if so equipped) is flat.



### CAUTION

- Never install tire chains on a punctured run-flat tire, as this could damage your vehicle.
- Avoid driving over any projection or pothole, as the clearance between the vehicle and the ground is smaller than normal.
- Do not enter an automated car wash with a punctured run-flat tire.
- Have the punctured tire replaced by your INFINITI dealer as soon as possible, as the tire’s performance capability is reduced.

## CHANGING A FLAT TIRE

If you have a flat tire, follow the instructions below.

### Stopping the vehicle

1. Safely move the vehicle off the road away from traffic.
2. Turn on the hazard warning flashers.
3. Park on a level surface and apply the parking brake. Shift the selector lever in P (Park) position.
4. Turn off the engine.
5. Raise the hood to warn other traffic, and to signal professional road assistance personnel that you need assistance.
6. Have all passengers get out of the vehicle and stand in a safe place, away from traffic and clear of the vehicle.



### WARNING

- **Make sure the parking brake is securely applied and the automatic transmission is shifted into P (Park).**
- **Never change tires when the vehicle is on a slope, ice or slippery areas. This is hazardous.**
- **Never change tires if oncoming traffic is close to your vehicle. Wait for professional road assistance.**

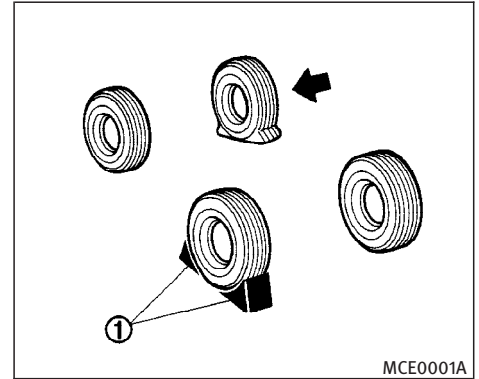

MCE0001A

### Blocking wheels

Place suitable blocks ① at both the front and back of the wheel diagonally opposite the flat tire to prevent the vehicle from rolling when it is jacked up.



### WARNING

**Be sure to block the wheel as the vehicle may move and result in personal injury.**



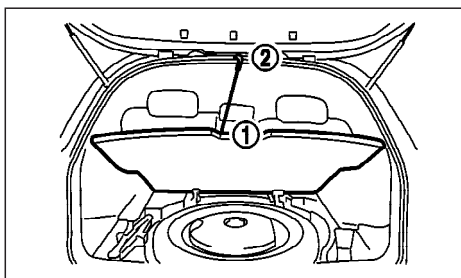

(A)

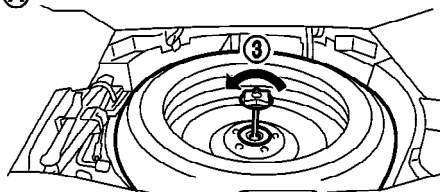

(B)

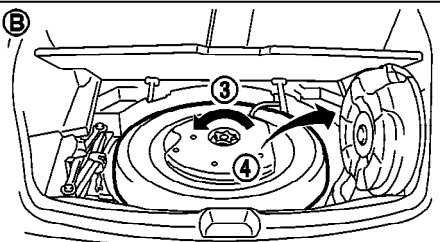

SCE0447A

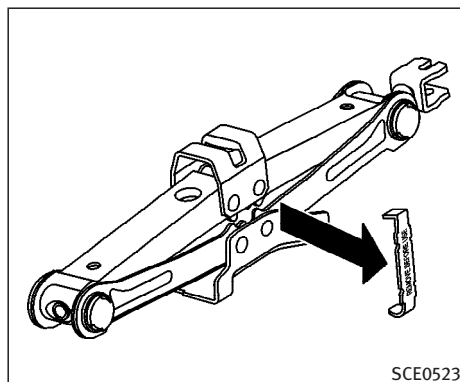

SCE0523

### Getting the spare tire and tools

Pull up the floor cover ① and hang the strap to upper body ② as illustrated.

(A):

Turn the retainer counterclockwise ③ and remove the spare tire.

(B):

Turn the retainer counterclockwise ③, remove the subwoofer ④ and place it on the side of the luggage room (with the flat surface facing down), then remove the spare

tire. Be careful not to let the subwoofer fall down.

Pull out the jack holder before using the jack as illustrated.

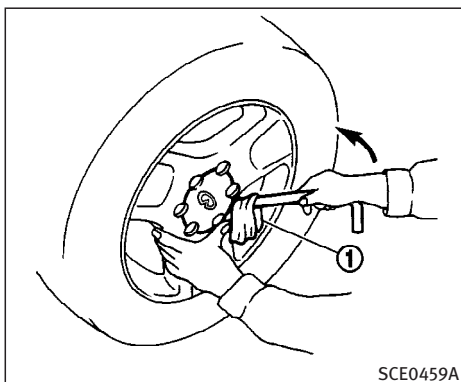

### Removing wheel cap

To remove the wheel cap, use the jack rod covered with a cloth ① as illustrated.



### CAUTION

**Do not use your hands to pry off wheel caps or wheel covers. Doing so could result in personal injury.**

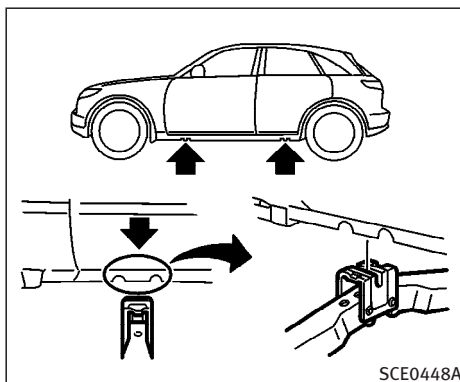

### Jack-up point

### Jacking up the vehicle and removing the damaged tire

**Carefully read the caution label attached to the jack body and the following instructions.**

1. Remove the jack holder loosening the jack shaft.
2. Place the jack directly under the jack-up point as illustrated above so that top of the jack contacts the vehicle at the jack up point. Align the jack head between the two notches in the front or the rear as shown. Also fit the groove of the jack head between the notches as shown.

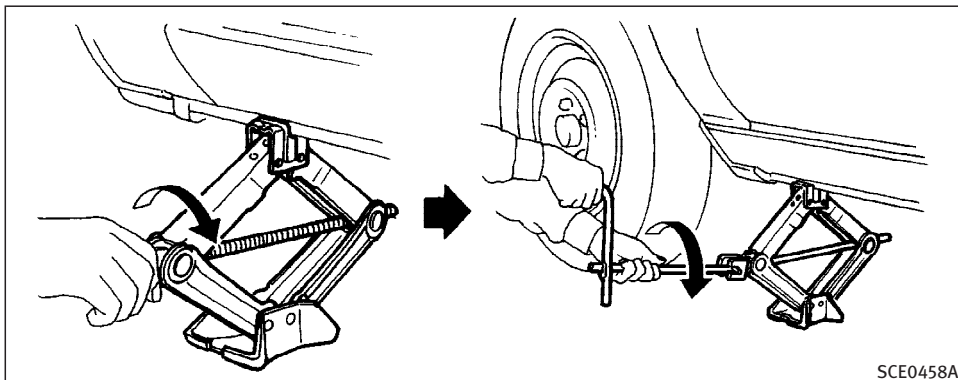

The jack should be used on level firm ground.

- Loosen each wheel nut one or two turns by turning counterclockwise with the wheel nut wrench. **Do not remove the wheel nuts until the tire is off the ground.**
- Carefully raise the vehicle until the tire clears the ground. To lift the vehicle, securely hold the jack lever and rod with both hands as shown above. Remove the wheel nuts, and then remove the tire.



## WARNING

- Don't use the jack with the holder attached in case it breaks, or it could lead to a personal injury.
- Never get under the vehicle while it is supported only by the jack. If it is necessary to work under the vehicle, support it with safety stands.
- Use only the jack provided with your vehicle to lift the vehicle. Do not use the

jack provided with other vehicles to your vehicle.

The jack is designed only for lifting your vehicle during a tire change.

- Use the correct jack-up points. Never use any other part of the vehicle for jack support.
- Never jack up the vehicle more than necessary.
- Never use blocks on or under the jack.
- Do not start or run the engine while the vehicle is on the jack. It may cause the vehicle to move. This is especially true for vehicles with limited slip differentials.
- Do not allow passengers to stay in the vehicle while it is on the jack.

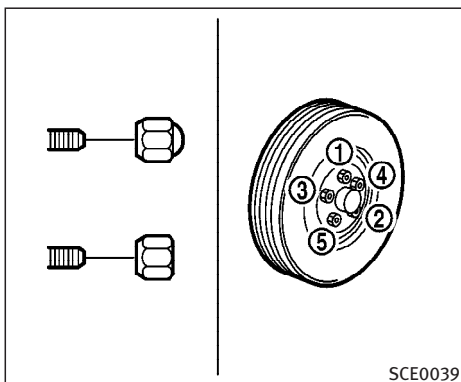

## Installing the spare tire

The T-type spare tire is designed for emergency use. See specific instructions under the heading “Wheels and tires” in the “8. Maintenance and do-it-yourself” section.

1. Clean any mud or dirt from the surface between the wheel and hub.
2. Carefully put the spare tire on and tighten the wheel nuts finger tight.
3. With the wheel nut wrench, tighten wheel nuts alternately and evenly as illustrated until they are tight.

## 6-8 In case of emergency

4. Lower the vehicle slowly until the tire touches the ground. Then, with the wheel nut wrench, tighten the wheel nuts securely in the sequence as illustrated (1, 2, 3, 4, 5). Lower the vehicle completely.



## WARNING

- Incorrect wheel nuts or improperly tightened wheel nuts can cause the wheel to become loose or come off. This could cause an accident.
- Do not use oil or grease on the wheel studs or nuts. This could cause the nuts to become loose.
- Retighten the wheel nuts after the vehicle has been driven for 600 miles (1,000 km) (also in cases of a flat tire, etc.).

**As soon as possible, tighten the wheel nuts to the specified torque with a torque wrench.**

**Wheel nut tightening torque:**

**80 ft-lb (108 N·m)**

**The wheel nuts must be kept tightened to specifications at all times. It is recommended that wheel nuts be tightened to specifications at each lubrication interval.**

**Adjust tire pressure to the COLD pressure.**

**COLD pressure:**

**After vehicle has been parked for three hours or more or driven less than 1 mile (1.6 km).**

**COLD tire pressures are shown on the Tire and Loading Information label affixed to the inside of the driver side center pillar.**

**For models equipped with the tire pressure monitoring system (TPMS):**

After adjusting tire pressure to the COLD tire pressure, the display of the tire pressure information may show higher pressure than the COLD tire pressure after the vehicle has been driven more than 1 mile (1.6 km). This is because the tire pressurizes as the tire temperature rises. This does not indicate a system malfunction.

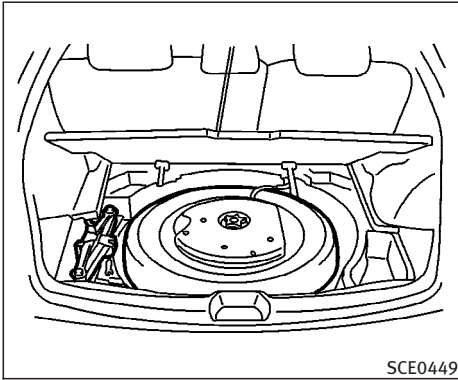

### Stowing the damaged tire and tools

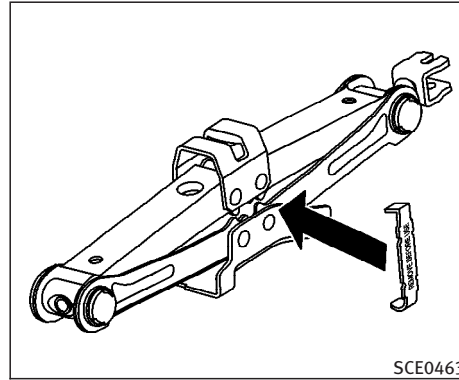

Install the jack holder in the correct direction. Refer to the illustration. Turn the jack handle to secure the jack holder to the jack.

Securely store the spare tire and jacking equipment in the vehicle.



### WARNING

- Always make sure that the spare tire and jacking equipment are properly secured after use. Such items can become dangerous projectiles in an accident or sudden stop.
- The T-type (temporary) spare tire and small size spare tire are designed for emergency use. See “Wheels and tires” in the “8. Maintenance and do-it-yourself” section.

If needed Roadside Assistance is available. Please see your INFINITI Warranty Information Booklet or Roadside Assistance I.D. Card for the toll-free number to call (U.S.) or Warranty Information Booklet (Canada).

## JUMP STARTING

To start your engine with a booster battery, the instructions and precautions below must be followed.



### WARNING

- If done incorrectly, jump starting can lead to a battery explosion, resulting in severe injury or death. It could also damage your vehicle.
- Explosive hydrogen gas is always present in the vicinity of the battery. Keep all sparks and flames away from the battery.
- Do not allow battery fluid to come into contact with eyes, skin, clothing or painted surfaces. Battery fluid is a corrosive sulfuric acid solution which can cause severe burns. If the fluid should come into contact with anything, immediately flush the contacted area with water.
- Keep battery out of the reach of children.

- The booster battery must be rated at 12 volts. Use of an improperly rated battery can damage your vehicle.
- Whenever working on or near a battery, always wear suitable eye protectors (for example, goggles or industrial safety spectacles) and remove rings, metal bands, or any other jewelry. Do not lean over the battery when jump starting.
- Do not attempt to jump start a frozen battery. It could explode and cause serious injury.
- Your vehicle has an automatic engine cooling fan. It could come on at any time. Keep hands and other objects away from it.
- If the battery of vehicle equipped with the Intelligent Key system is discharged, the ignition switch cannot be moved from the LOCK position, even using the mechanical key or the valet key. Connect the jumper cables to another vehicle, as

in the case of a discharged battery, and then the ignition knob can be moved from the LOCK position. Then, jump start the vehicle.

If needed Roadside Assistance is available. Please see your INFINITI Warranty Information Booklet or Roadside Assistance I.D. Card for the toll-free number to call (U.S.) or INFINITI Warranty Information Booklet (Canada).

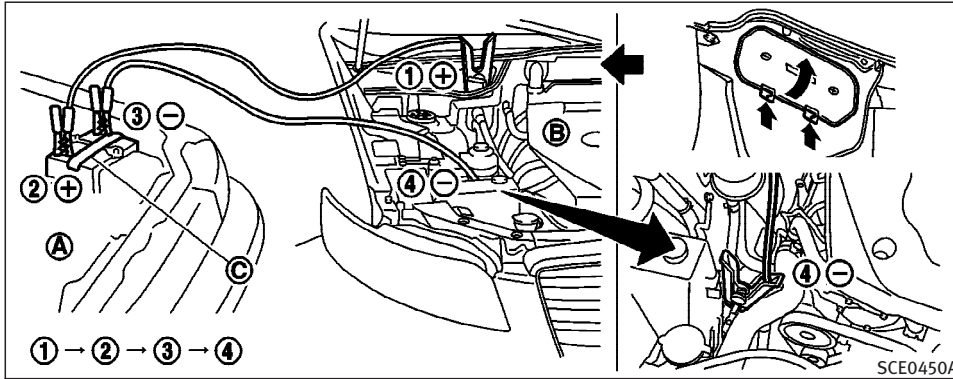

VQ35DE engine

SCE0450A



## WARNING

Always follow the instructions below. Failure to do so could result in damage to the charging system and cause personal injury.

1. If the booster battery is in another vehicle (A), position the two vehicles (A) and the jumped vehicle: (B) to bring their batteries into close proximity to each other.

**Do not allow the two vehicles to touch.**

2. Apply parking brake. Move the selector lever to the P (Park) position. Switch off all unnecessary electrical systems (light, heater, air conditioner, etc.).
3. Remove vent caps on the battery (if so equipped). Cover the battery with an old cloth (C) to reduce explosion hazard.
4. Connect jumper cables in the sequence as illustrated (1) → (2) → (3) → (4).



## CAUTION

- Always connect positive (+) to positive (+) and negative (-) to body ground (for example, strut mounting bolt, etc. — not to the battery).
- Make sure the jumper cables do not touch moving parts in the engine compartment and that the cable clamps do not contact any other metal.

5. Start the engine of the booster vehicle (A) and let it run for a few minutes.
6. Keep the engine speed of the booster vehicle (A) at about 2,000 rpm, and start the jumped vehicle (B) in the normal manner.



## CAUTION

**Do not keep the starter motor engaged for more than 10 seconds. If the engine does not start right away, turn the key off and wait 3 to 4 seconds before trying again.**

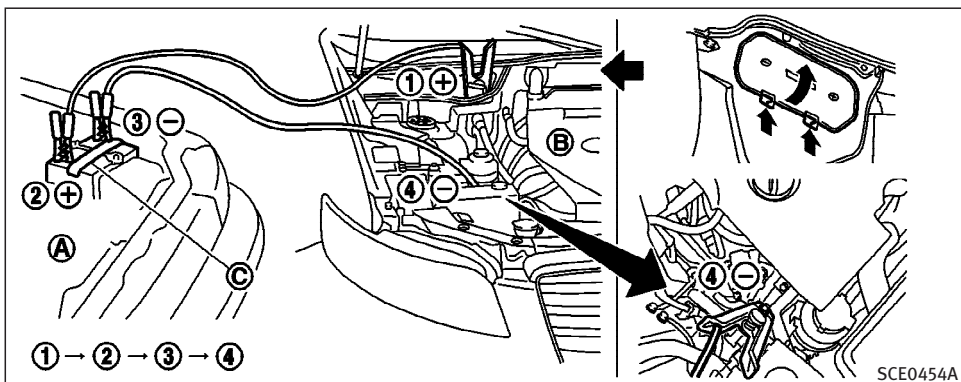

**VK45DE engine**

7. After starting your engine, carefully disconnect the negative cable and then the positive cable (4 → 3 → 2 → 1).
8. Replace the vent caps (if so equipped). Be sure to dispose of the cloth used to cover the vent holes as it may be contaminated with corrosive acid.

## PUSH STARTING

Do not attempt to start the engine by pushing.



### CAUTION

Automatic transmission models cannot be push-started or tow-started. Attempting to do so may cause transmission or other vehicle damage.

If needed Roadside Assistance is available. Please see your INFINITI Warranty Information Booklet or Roadside Assistance I.D. Card for the toll-free number to call (U.S.) or INFINITI Warranty Information Booklet (Canada).



## IF YOUR VEHICLE OVERHEATS



### WARNING

- Do not continue to drive if your vehicle overheats. Doing so could cause engine damage or a vehicle fire.
- To avoid the danger of being scalded, never remove the radiator cap while the engine is still hot. When the radiator cap is removed, pressurized hot water will spurt out, possibly causing serious injury.
- Do not open the hood if steam is coming out.

If your vehicle is overheating (indicated by an extremely high temperature gauge reading), or if you feel a lack of engine power, detect abnormal noise, etc., take the following steps:

1. Move the vehicle safely off the road, apply the parking brake and move the selector lever to the P (Park) position.  
**Do not stop the engine.**
2. Turn off the air conditioner switch. Open all the windows, move the heater

or air conditioner temperature control to maximum hot and fan control to high speed.

3. If engine overheating is caused by climbing a long hill on a hot day, run the engine at a fast idle (approximately 1,500 rpm) until the temperature gauge indication returns to normal.
4. Get out of the vehicle. Look and listen for steam or coolant escaping from the radiator before opening the hood. (If steam or coolant is escaping, turn off the engine.) Do not open the hood further until no steam or coolant can be seen.
5. Open the engine hood.



### WARNING

**If steam or water is coming from the engine, stand clear to prevent getting burned.**

6. Visually check if the cooling fan is running. The radiator hoses and radiator should not leak water.  
  
If coolant is leaking or the cooling fan does not run, stop the engine.



### WARNING

**Be careful not to allow your hands, hair, jewelry or clothing to come into contact with, or get caught in, engine belts or the engine cooling fan. The engine cooling fan can start at any time when the coolant temperature is high.**

7. After the engine cools down, check the coolant level in the reservoir tank with the engine running. Add coolant to the reservoir tank if necessary. Have your vehicle repaired at an INFINITI dealer.

If needed, Roadside Assistance is available. Please see your INFINITI Warranty Information Booklet or Roadside Assistance I.D. Card for the toll-free number to call (U.S.) or INFINITI Warranty Information Booklet (Canada).

## TOWING YOUR VEHICLE

When towing your vehicle, all State (Provincial in Canada) and local regulations for towing must be followed. Incorrect towing equipment could damage your vehicle. Towing instructions are available from an INFINITI dealer. Local service operators are generally familiar with the applicable laws and procedures for towing. To assure proper towing and to prevent accidental damage to your vehicle, INFINITI recommends having a service operator tow your vehicle. It is advisable to have the service operator carefully read the following precautions.



### WARNING

- Never ride in a vehicle that is being towed.
- Never get under your vehicle after it has been lifted by a tow truck.



### CAUTION

- When towing, make sure that the transmission, axles, steering system and

**powertrain are in working condition. If any unit is damaged, dollies must be used.**

- **Always attach safety chains before towing.**

If needed, Roadside Assistance is available. Please see your INFINITI Warranty Information Booklet or Roadside Assistance I.D. Card for the toll-free number to call (U.S.) or INFINITI Warranty Information Booklet (Canada).

For information about towing your vehicle behind a recreational vehicle (RV), refer to “Flat towing” in the “9. Technical and consumer information” section of this manual.

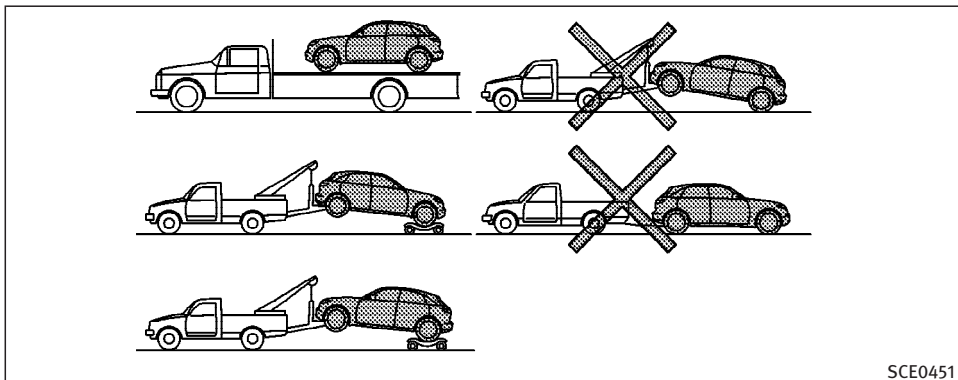

SCE0451

### Two-wheel drive (2WD) models TOWING RECOMMENDED BY INFINITI

Two-wheel drive (2WD) models  
INFINITI recommends that your vehicle be  
towed with the driving (rear) wheels off the  
ground or place the vehicle on a flat bed  
truck as illustrated.



### CAUTION

- Never tow automatic transmission models with the rear wheels on the

ground or four wheels on the ground (forward or backward), as this may cause serious and expensive damage to the transmission.

If it is necessary to tow the vehicle with the front wheels raised, always use towing dollies under the rear wheels.

- When towing rear wheel drive models with the front wheels on the ground or on towing dollies:

Turn the ignition key to the OFF position, and secure the steering wheel in a straight ahead position with a rope or similar device. Never secure the steering wheel by turning the ignition key to the LOCK position. This may damage the steering lock mechanism.

Move the selector lever to the N (Neutral) position.

- When the battery of vehicle equipped with the Intelligent Key system is discharged, your vehicle should be towed with the front wheels on towing dollies or place the vehicle on a flat bed truck.

If the speed or distance must necessarily be greater, remove the propeller shaft before towing to prevent damage to the transmission.

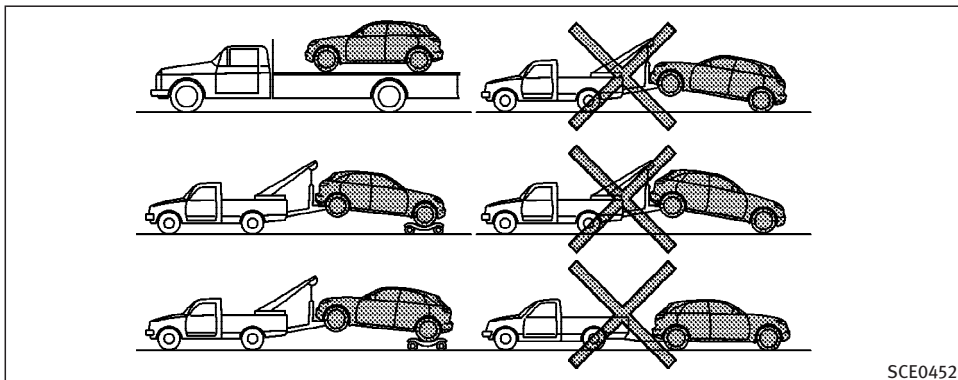

**All-wheel drive (AWD) models**  
**All-wheel drive (AWD) models**

INFINITI recommends that towing dollies be used when towing your vehicle or the vehicle be placed on a flat bed truck as illustrated.



**CAUTION**

Never tow AWD models with any of the wheels on the ground as this may cause serious and expensive damage to the power train.

6-16 In case of emergency

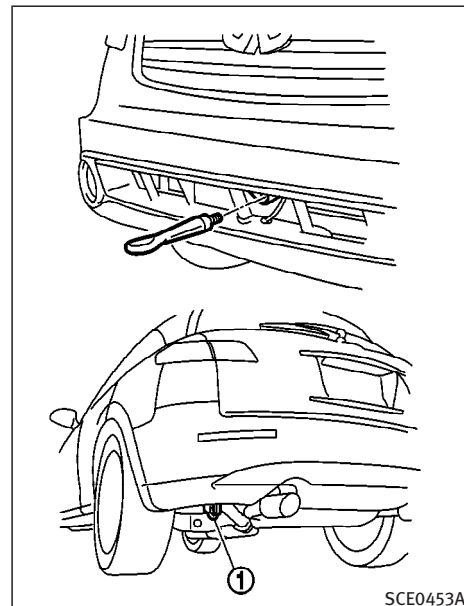

① Do not use for towing.

**VEHICLE RECOVERY (Freeing a stuck vehicle)**

Securely install the vehicle recovery hook stored with jacking tools.

Make sure that the hook is properly secured in the stored place after use.



## WARNING

- Stand clear of a stuck vehicle.
- Do not spin your tires at high speed. This could cause them to explode and result in serious injury. Parts of your vehicle could also overheat and be damaged.



## CAUTION

- Tow chains or cables must be attached only to the vehicle recovery hooks or main structural members of the vehicle. Otherwise, the vehicle body will be damaged.
- Do not use the vehicle tie downs to free a vehicle stuck in sand, snow, mud, etc. Never tow the vehicle using the vehicle tie downs or recovery hooks.

- Always pull the cable straight out from the front of the vehicle. Never pull on the hook at an angle.
- Pulling devices should be routed so they do not touch any part of the suspension, steering, brake or cooling systems.
- Pulling devices such as ropes or canvas straps are not recommended for use in vehicle towing or recovery.

## Automatic transmission

To tow a vehicle equipped with an automatic transmission, an appropriate vehicle dolly **MUST** be placed under the towed vehicle's drive wheels. **Always** follow the dolly manufacturer's recommendations when using their product.

If your vehicle is stuck in sand, snow, mud, etc., use the following procedure:

1. Turn off the Vehicle Dynamic Control System.

2. Make sure the area in front and behind the vehicle is clear of obstructions.
3. Turn the steering wheel right and left to clear an area around the front tires.
4. Slowly rock the vehicle forward and backward.

Shift back and forth between R (reverse) and D (drive).

Apply the accelerator as little as possible to maintain the rocking motion.

Release the accelerator pedal before shifting between R and D.

Do not spin the tires above 35 MPH (55 km/h).

5. If the vehicle can not be freed after a few tries, contact a professional towing service to remove the vehicle.

**MEMO**

**6-18 In case of emergency**

# 7 Appearance and care

Cleaning exterior .....	7-2
Washing.....	7-2
Waxing.....	7-2
Removing spots.....	7-2
Underbody .....	7-3
Glass .....	7-3
Aluminum alloy wheels .....	7-3
Chrome parts .....	7-3
Tire dressing .....	7-3

Cleaning interior.....	7-4
Floor mats .....	7-4
Seat belts.....	7-5
Corrosion protection .....	7-5
Most common factors contributing to vehicle corrosion .....	7-5
Environmental factors influence the rate of corrosion.....	7-5
To protect your vehicle from corrosion.....	7-5

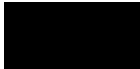

## CLEANING EXTERIOR

In order to maintain the appearance of your vehicle, it is important to take proper care of it.

In the following cases, please wash your vehicle as soon as possible to protect the paint surface.

- After a rainfall to prevent possible damage from acid rain
- After driving on coastal roads
- When contaminants such as soot, bird droppings, tree sap, metal particles or bugs get on the paint surface
- When dust or mud builds up on the surface

Whenever possible, store or park your vehicle inside a garage or in a covered area.

When it is necessary to park outside, park in a shady area or protect the vehicle with a body cover.

**Be careful not to scratch the paint surface when putting on or removing the body cover.**

### WASHING

Wash dirt off the vehicle with a wet sponge and plenty of water. Clean the vehicle thoroughly using a mild soap, a special vehicle

#### 7-2 Appearance and care

soap or a general purpose dish-washing liquid mixed with clean, lukewarm (never hot) water.



### CAUTION

- **Do not use strong household soap, strong chemical detergents, gasoline or solvents.**
- **Do not wash the vehicle in direct sunlight or while the vehicle body is hot, as the surface may become water-spotted.**
- **Avoid using tight-napped or rough cloths, such as washing mitts. Care must be taken when removing caked-on dirt or other foreign substances so that the paint surface is not scratched or damaged.**

Rinse the vehicle again with plenty of clean water.

Inside flanges, seams and folds on the doors, hatches and hood are particularly vulnerable to the effects of road salt. Therefore, these areas must be regularly cleaned. Make sure that the drain holes in the lower edge of the door are open. Spray water

under the body and in the wheel wells to loosen the dirt and wash away road salt.

Avoid leaving water spots on the paint surface by using a damp chamois to dry the vehicle.

### WAXING

Regular waxing protects the paint surface and helps retain new vehicle appearance. Polishing is recommended to remove built-up residue and to avoid a weathered appearance before reapplying wax.

An INFINITI dealer can assist you in choosing the proper product.

- Wax your vehicle only after a thorough washing. Follow the instructions supplied with the wax.
- Do not use a wax containing any abrasives, cutting compounds or cleaners that may damage the vehicle finish.

Machine compounding or aggressive polishing on a base coat/clear coat paint finish may dull the finish or leave swirl marks.

### REMOVING SPOTS

Remove tar and oil spots, industrial dust, insects, and tree sap as quickly as possible



from the surface of the paint to avoid lasting damage or staining. Special cleaning products are available at an INFINITI dealer or any automotive accessory store.

## UNDERBODY

In areas where road salt is used in winter, the underbody must be cleaned regularly. This will prevent dirt and salt from building up and causing underbody and suspension corrosion. Before the winter period and again in the spring, the underseal must be checked and, if necessary, re-treated.

## GLASS

Use glass cleaner to remove smoke and dust film from the glass surfaces. It is normal for glass to become coated with a film after the vehicle is parked in the hot sun. Glass cleaner and a soft cloth will easily remove this film.



### CAUTION

**When cleaning the inside of the windows, do not use sharp-edged tools, abrasive cleaners**

**or chlorine-based disinfectant cleaners. They could damage the electrical conductors, radio antenna elements or rear window defroster elements.**

## ALUMINUM ALLOY WHEELS

Wash regularly, especially during winter months in areas where road salt is used. Salt could discolor the wheel if not removed.

## CHROME PARTS

Clean all chrome parts regularly with a non-abrasive chrome polish to maintain the finish.

## TIRE DRESSING

INFINITI does not recommend the use of tire dressings. Tire manufacturers apply a coating to the tires to help reduce discoloration of the rubber. If a tire dressing is applied to the tires, it may react with the coating and form a compound. This compound may come off the tire while driving and stain the vehicle paint.

If you choose to use a tire dressing, take the following precautions:

- Use a water-based tire dressing. The coating on the tire dissolves more easily with an oil-based tire dressing.
- Apply a light coat of tire dressing to help prevent it from entering the tire tread/grooves (where it would be difficult to remove).
- Wipe off excess tire dressing using a dry towel. Make sure the tire dressing is completely removed from the tire tread/grooves.
- Allow the tire dressing to dry as recommended by tire dressing manufacturer.

## CLEANING INTERIOR

Occasionally remove loose dust from the interior trim, plastic parts and seats using a vacuum cleaner or soft bristled brush. Wipe the vinyl and leather surfaces with a clean, soft cloth dampened in mild soap solution, then wipe clean with a dry soft cloth.

Regular care and cleaning is required in order to maintain the appearance of the leather.

Before using any fabric protector, read the manufacturer's recommendations. Some fabric protectors contain chemicals that may stain or bleach the seat material.

Use a cloth dampened only with water, to clean the meter and gauge lens.



### CAUTION

- Never use benzine, thinner or any similar material.

- Small dirt particles can be abrasive and damaging to leather surfaces and should be removed promptly. Do not use saddle soap, car waxes, polishes, oils, cleaning fluids, solvents, detergents or ammonia-based cleaners as they may damage the leather natural finish.
- Never use fabric protectors unless recommended by the manufacturer.
- Do not use glass or plastic cleaner on meter or gauge lens covers. It may damage the lens cover.

## FLOOR MATS

The use of genuine INFINITI floor mats can extend the life of your vehicle carpet and make it easier to clean the interior. **No matter what mats are used, be sure they are fitted for your vehicle and are properly positioned in the footwell to prevent interference with pedal operation.** Mats should be maintained with regular cleaning and replaced if they become excessively worn.

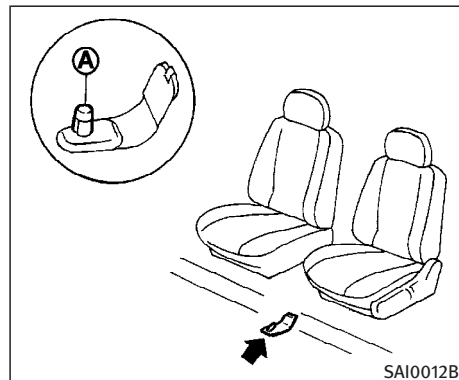

### Floor mat positioning aid (driver's side only)

This model includes a front floor mat bracket (A) to act as a floor mat positioning aid. INFINITI floor mats have been specially designed for your vehicle model. The driver's side floor mat has a grommet hole incorporated in it. Simply position the mat by placing the floor mat bracket through the floor mat grommet hole while centering the mat in the floor pan contour.

Periodically check to make certain that the mats are properly positioned.

## SEAT BELTS

The seat belts can be cleaned by wiping them with a sponge dampened in a mild soap solution. Allow the belts to dry completely before using them. See “Seat belt maintenance” in the “1. Safety — Seats, seat belts and supplemental restraint system” section.



### WARNING

Do not allow wet seat belts to roll up in the retractor. NEVER use bleach, dye or chemical solvents to clean the seat belts, since these materials may severely weaken the seat belt webbing.

## CORROSION PROTECTION

### MOST COMMON FACTORS CONTRIBUTING TO VEHICLE CORROSION

- The accumulation of moisture-retaining dirt and debris in body panel sections, cavities, and other areas.
- Damage to paint and other protective coatings caused by gravel and stone chips or minor traffic accidents.

### ENVIRONMENTAL FACTORS INFLUENCE THE RATE OF CORROSION

#### Moisture

Accumulation of sand, dirt and water on the vehicle body underside can accelerate corrosion. Wet floor coverings will not dry completely inside the vehicle, and should be removed for drying to avoid floor panel corrosion.

#### Relative humidity

Corrosion will be accelerated in areas of high relative humidity, especially those areas where the temperatures stay above freezing and where atmospheric pollution exists and road salt is used.

#### Temperature

A temperature increase will accelerate the rate of corrosion to those parts which are not well ventilated.

#### Air pollution

Industrial pollution, the presence of salt in the air in coastal areas, or heavy road salt use will accelerate the corrosion process. Road salt will also accelerate the disintegration of paint surfaces.

### TO PROTECT YOUR VEHICLE FROM CORROSION

- Wash and wax your vehicle often to keep the vehicle clean.
- Always check for minor damage to the paint and repair it as soon as possible.
- Keep drain holes at the bottom of the doors open to avoid water accumulation.
- Check the underbody for accumulation of sand, dirt or salt. If present, wash with water as soon as possible.



## CAUTION

- **NEVER** remove dirt, sand or other debris from the passenger compartment by washing it out with a hose. Remove dirt with a vacuum cleaner or broom.
- Never allow water or other liquids to come in contact with electronic components inside the vehicle as this may damage them.

Chemicals used for road surface de-icing are extremely corrosive. They accelerate corrosion and deterioration of underbody components such as the exhaust system, fuel and brake lines, brake cables, floor pan and fenders.

**In winter, the underbody must be cleaned periodically.**

For additional protection against rust and corrosion, which may be required in some areas, consult an INFINITI dealer.

# 8 Maintenance and do-it-yourself

Maintenance requirements.....	8-2	Cleaning.....	8-21
General maintenance .....	8-2	Replacing.....	8-22
Explanation of general maintenance		Rear window wiper blade .....	8-23
items .....	8-3	Parking brake and brake pedal.....	8-23
Maintenance precautions.....	8-5	Checking parking brake .....	8-23
Engine compartment check locations.....	8-7	Checking brake pedal .....	8-23
Engine cooling system .....	8-9	Brake booster.....	8-24
Checking engine coolant level.....	8-9	Fuses .....	8-24
Changing engine coolant .....	8-10	Engine compartment.....	8-25
Engine oil .....	8-11	Passenger compartment .....	8-26
Checking engine oil level .....	8-11	Keyfob battery replacement.....	8-27
Changing engine oil and filter .....	8-13	Keyfob (Except Intelligent Key).....	8-27
Automatic transmission fluid.....	8-15	Intelligent Key.....	8-28
Power steering fluid .....	8-15	Lights.....	8-30
Brake fluid.....	8-16	Headlights .....	8-31
Window washer fluid.....	8-16	Exterior and interior lights .....	8-31
Battery .....	8-17	Wheels and tires .....	8-35
Jump starting.....	8-19	Tire pressure .....	8-35
Drive belts .....	8-19	Tire labeling .....	8-38
Spark plugs .....	8-20	Types of tires.....	8-40
Replacing spark plugs .....	8-20	Tire chains .....	8-42
Air cleaner.....	8-21	Changing wheels and tires.....	8-43
Windshield wiper blades.....	8-21		

## MAINTENANCE REQUIREMENTS

Your new INFINITI has been designed to have minimum maintenance requirements with longer service intervals to save you both time and money. However, some day-to-day and regular maintenance is essential to maintain your INFINITI's good mechanical condition, as well as its emission and engine performance.

It is the owner's responsibility to make sure that the specified maintenance and the general maintenance are performed.

As the vehicle owner, you are the only one who can ensure that your vehicle receives the proper maintenance care. You are a vital link in the maintenance chain.

### **Scheduled maintenance:**

For your convenience, both required and optional scheduled maintenance items are described and listed in your "INFINITI Service and Maintenance Guide". You must refer to that guide to ensure that necessary maintenance is performed on your INFINITI at regular intervals.

### **General maintenance:**

General maintenance includes those items which should be checked during normal day-to-day operation. They are essential for proper vehicle operation. It is your re-

## 8-2 Maintenance and do-it-yourself

sponsibility to perform these maintenance procedures regularly as prescribed.

Performing general maintenance checks requires minimal mechanical skill and only a few general automotive tools.

These checks or inspections can be done by you, a qualified technician, or, if you prefer, an INFINITI dealer.

### **Where to go for service:**

If maintenance service is required or your vehicle appears to malfunction, have the systems checked and serviced by an INFINITI dealer.

INFINITI technicians are well-trained specialists and are kept up to date with the latest service information through technical bulletins, service tips, and in-dealership information systems. They are completely qualified to work on INFINITI vehicles **before** work begins.

You can be confident that an INFINITI dealer's service department performs the best job to meet the maintenance requirements on your vehicle — in a reliable and economic way.

## GENERAL MAINTENANCE

During the normal day-to-day operation of the vehicle, general maintenance should be performed regularly as prescribed in this section. If you detect any unusual sounds, vibrations or smell, be sure to check for the cause or have an INFINITI dealer perform it promptly. In addition, you should notify an INFINITI dealer if you think the repairs are required.

When performing any checks or maintenance work, closely observe the "Maintenance precautions" later in this section.

## EXPLANATION OF GENERAL MAINTENANCE ITEMS

**Additional information on the following items with “\*” is found later in this section.**

### Outside the vehicle

The maintenance items listed here should be performed from time to time, unless otherwise specified.

**Doors and engine hood:** Check that all doors and the engine hood operate properly. Also ensure that all latches lock securely. Lubricate hinges and latches if necessary. Make sure that the secondary latch keeps the hood from opening when the primary latch is released.

When driving in areas using road salt or other corrosive materials, check lubrication frequently.

**Lights\*:** Clean the headlights on a regular basis. Make sure that the headlights, stop lights, tail lights, turn signal lights, and other lights are all operating properly and installed securely. Also check headlight aim.

**Road wheel nuts (lug nuts):** When checking the tires, make sure no wheel nuts are

missing, and check for any loose wheel nuts. Tighten if necessary.

**Tires\*:** Check the pressure with a gauge often and always prior to long distance trips. If necessary, adjust the pressure in all tires, including the spare (if so equipped), to the specified pressure. Check carefully for damage, cuts or excessive wear.

#### **Tire rotation\*:**

The tires should be rotated every 7,500 miles (12,000 km) to minimize tire wear variation.

**Tire, wheel alignment and balance:** If the vehicle should pull to either side while driving on a straight and level road, or if you detect uneven or abnormal tire wear, there may be a need for wheel alignment.

If the steering wheel or seat vibrates at normal highway speeds, wheel balancing may be needed.

- For additional information regarding tires, refer to “Important Tire Safety Information” (US) or “Tire Safety Information” (Canada) in the Warranty Information Booklet.

**Windshield:** Clean the windshield on a regular basis. Check the windshield at least every six months for cracks or other

damage. Have a damaged windshield repaired by a qualified repair facility.

**Windshield wiper blades\*:** Check for cracks or wear if they do not wipe properly.

## Inside the vehicle

The maintenance items listed here should be checked on a regular basis, such as when performing periodic maintenance, cleaning the vehicle, etc.

**Accelerator pedal:** Check the pedal for smooth operation and make sure the pedal does not catch or require uneven effort. Keep the floor mat away from the pedal.

**Automatic transmission P (Park) mechanism:** On a fairly steep hill check that your vehicle is held securely with the selector lever in the P (Park) position without applying any brakes.

**Brake pedal\*:** Check the pedal for smooth operation and make sure it has the proper distance under it when depressed fully. Check the brake booster function. Be sure to keep the floor mat away from the pedal.

**Brakes:** Check that the brakes do not pull the vehicle to one side when applied.

**Parking brake\*:** Check that the lever/pedal has the proper travel and confirm that your vehicle is held securely on a fairly steep hill with only the parking brake applied.

**Seats:** Check seat position controls such as seat adjusters, seatback recliner, etc. to ensure they operate smoothly and that all latches lock securely in every position. Check that the head restraints move up and down smoothly and that the locks (if so equipped) hold securely in all latched positions.

**Seat belts:** Check that all parts of the seat belt system (For example, buckles, anchors, adjusters and retractors) operate properly and smoothly, and are installed securely. Check the belt webbing for cuts, fraying, wear or damage.

**Steering wheel:** Check for changes in the steering conditions, such as excessive free play, hard steering or strange noises.

**Warning lights and chimes:** Make sure that all warning lights and chimes are operating properly.

**Windshield defroster:** Check that the air comes out of the defroster outlets properly and in sufficient quantity when operating the heater or air conditioner.

**Windshield wiper and washer\*:** Check that the wipers and washer operate properly and that the wipers do not streak.

## Under the hood and the vehicle

The maintenance items listed here should be checked periodically (For example, each time you check the engine oil or refuel).

**Battery\*:** Check the fluid level in each cell. It should be between the MAX and MIN lines. Vehicles operated in high temperatures or under severe conditions require frequent checks of the battery fluid level.

**Brake fluid level\*:** Make sure that the brake and clutch fluid levels are between the MAX and MIN lines on the reservoir.

**Engine coolant level\*:** Check the coolant level when the engine is cold.

**Engine drive belts\*:** Make sure that no belt is frayed, worn, cracked or oily.

**Engine oil level\*:** Check the level after parking the vehicle on a level location and turning off the engine. (Wait at least 10 minutes for the oil to drain back into the oil pan.)

**Exhaust system:** Make sure there are no loose supports, cracks or holes. If the sound of the exhaust seems unusual or there is a smell of exhaust fumes, imme-



diately locate the trouble and correct it. See “Precautions when starting and driving” in the “5. Starting and driving” section for exhaust gas (Carbon monoxide).

**Fluid leaks:** Check under the vehicle for fuel, oil, water or other fluid leaks after the vehicle has been parked for a while. Water dripping from the air conditioner after use is normal. If you should notice any leaks or if gasoline fumes are evident, check for the cause and have it corrected immediately.

**Power steering fluid level\* and lines:** Check the level when the fluid is cold and the engine is turned off. Check the lines for proper attachment, leaks, cracks, etc.

**Radiator and hoses:** Check the front of the radiator and clean off any dirt, insects, leaves, etc., that may have accumulated. Make sure the hoses have no cracks, deformation, deterioration or loose connections.

**Underbody:** The underbody is frequently exposed to corrosive substances such as those used on icy roads or to control dust. It is very important to remove these substances, otherwise rust will form on the floor pan, frame, fuel lines and around the exhaust system. At the end of winter, the underbody should be thoroughly flushed

with plain water, being careful to clean those areas where mud and dirt may accumulate. For additional information, see “Cleaning exterior” in the “7. Appearance and care” section.

**Window washer fluid\*:** Check that there is adequate fluid in the tank.

## MAINTENANCE PRECAUTIONS

When performing any inspection or maintenance work on your vehicle, always take care to prevent serious accidental injury to yourself or damage to the vehicle. The following are general precautions which should be closely observed.



### WARNING

- Park the vehicle on a level surface, apply the parking brake securely and block the wheels to prevent the vehicle from moving. Move the selector lever to P (Park) position.
- Be sure the ignition key is in the OFF or LOCK position when performing any parts replacement or repairs.
- Your vehicle is equipped with an automatic engine cooling fan. It may come on at any time without warning, even if the ignition key is in the OFF position and the engine is not running. To avoid injury, always disconnect the negative battery cable before working near the fan.

- If you must work with the engine running, keep your hands, clothing, hair and tools away from moving fans, belts and any other moving parts.
- It is advisable to secure or remove any loose clothing and any jewelry, such as rings, watches, etc. before working on your vehicle.
- Always wear eye protection whenever you work on your vehicle.
- If you must run the engine in an enclosed space such as a garage, be sure there is proper ventilation for exhaust gases to escape.
- Never get under the vehicle while it is supported only by a jack. If it is necessary to work under the vehicle, support it with safety stands.
- Keep smoking materials, flame and sparks away from the fuel tank and battery.
- On gasoline engine models with the Multiport Fuel Injection (MFI) System, the fuel filter or fuel lines should be serviced

by an INFINITI dealer because the fuel lines are under high pressure even when the engine is off.



## CAUTION

- Do not work under the hood while the engine is hot. Turn the engine off and wait until it cools down.
- Never connect or disconnect the battery or any transistorized component while the ignition switch is in the ON position.
- Never leave any engine or automatic transmission related component harness connector disconnected while the ignition switch is in the ON position.
- Avoid contact with used engine oil and coolant. Improperly disposed engine oil, engine coolant and/or other vehicle fluids can damage the environment. Always conform to local regulations for disposal of vehicle fluid.

This “8. Maintenance and do-it-yourself” section gives instructions regarding only those items which are relatively easy for an owner to perform.

A genuine INFINITI Service Manual is also available. See “Owner’s Manual/Service Manual order information” in the “9. Technical and consumer information” section.

You should be aware that incomplete or improper servicing may result in operating difficulties or excessive emissions, and could affect your warranty coverage. **If in doubt about any servicing, have it done by an INFINITI dealer.**

## ENGINE COMPARTMENT CHECK LOCATIONS

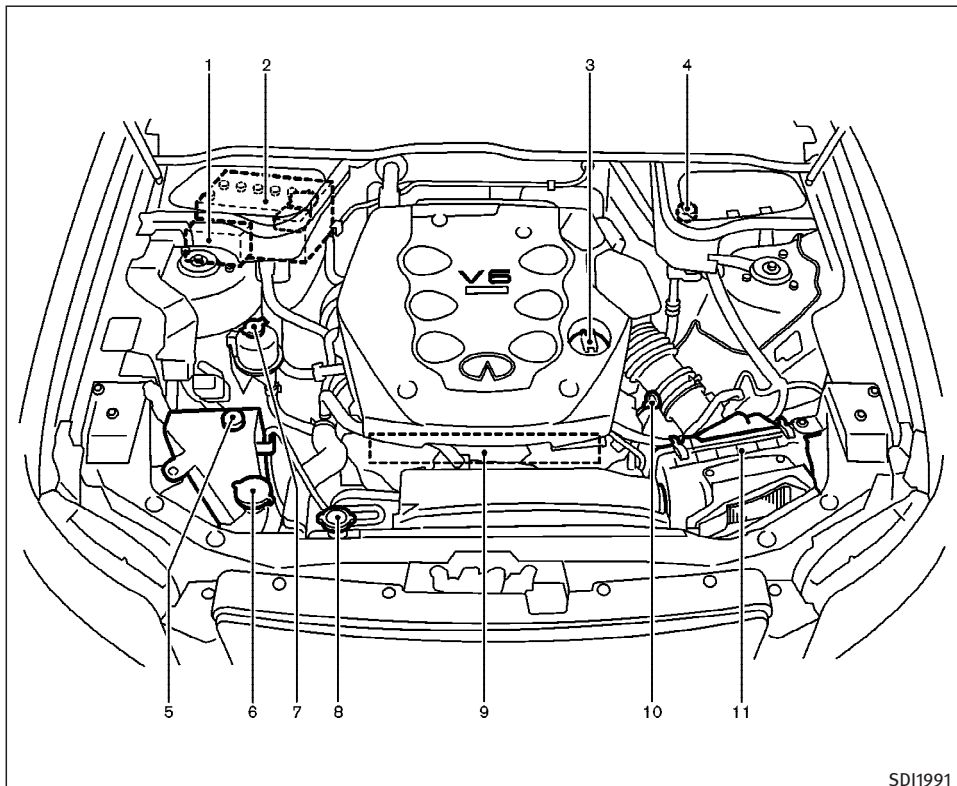

SDI1991

### VQ35DE engine

1. Fuse/fusible link holder
2. Battery
3. Engine oil filler cap
4. Brake fluid reservoir
5. Engine coolant reservoir
6. Window washer fluid reservoir
7. Power steering fluid reservoir
8. Radiator filler cap
9. Drive belts
10. Engine oil dipstick
11. Air cleaner

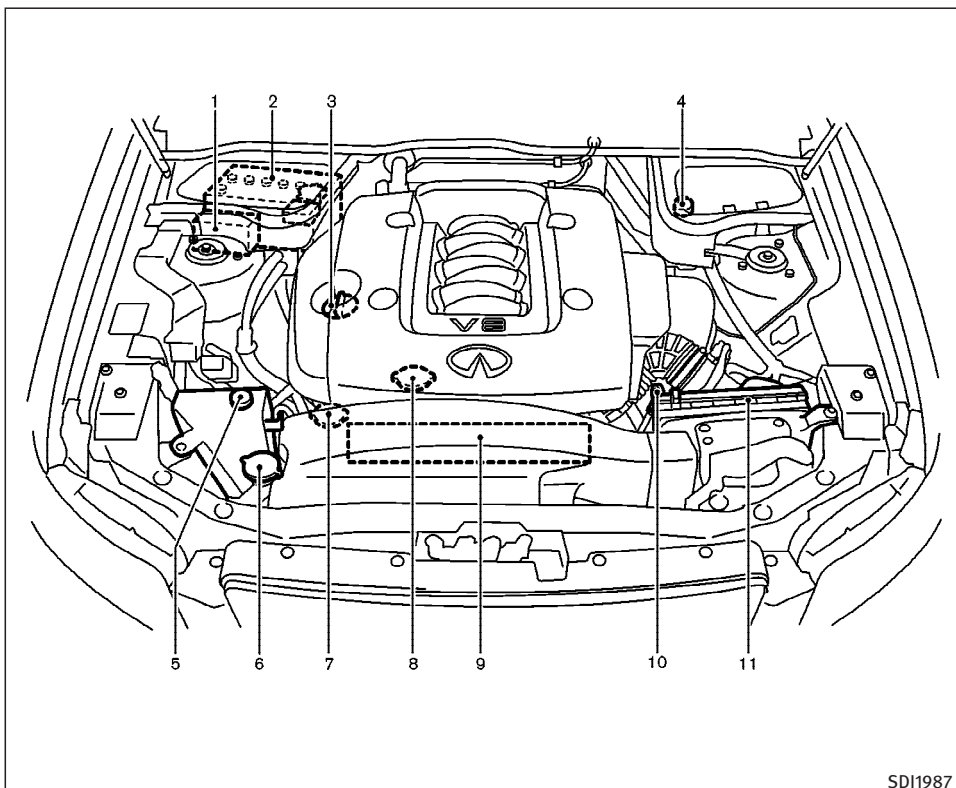

### VK45DE engine

1. Fuse/fusible link holder
2. Battery
3. Engine oil filler cap
4. Brake fluid reservoir
5. Engine coolant reservoir
6. Window washer fluid reservoir
7. Power steering fluid reservoir
8. Radiator filler cap
9. Drive belts
10. Engine oil dipstick
11. Air cleaner

SDI1987

## ENGINE COOLING SYSTEM

The engine cooling system is filled at the factory with a high-quality, year-round, anti-freeze coolant solution. The anti-freeze solution contains rust and corrosion inhibitors, therefore additional cooling system additives are not necessary.



### WARNING

- Never remove the radiator cap when the engine is hot. Wait until the engine and radiator cool down. Serious burns could be caused by high pressure fluid escaping from the radiator. See “If your vehicle overheats” in the “6. In case of emergency” section.
- The radiator is equipped with a pressure type radiator cap. To prevent engine damage, use only a genuine NISSAN radiator cap.

Outside temperature down to		Anti-freeze	Demineralized water/ distilled water
°C	°F		
-35	-30	50%	50%



### CAUTION

When adding or replacing coolant, be sure to use only a Genuine NISSAN Long Life Anti-freeze Coolant (green) or equivalent with the proper mixture ratio of 50% anti-freeze and 50% demineralized or distilled water. The use of other types of coolant solutions or coolant colors, such as orange, may damage your engine cooling system.

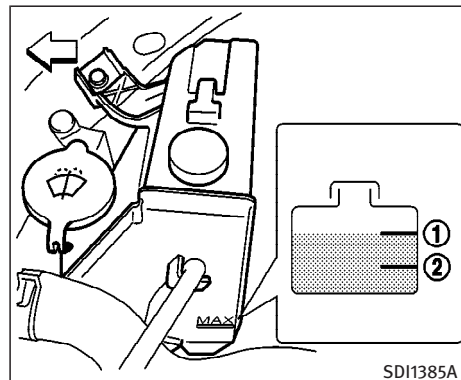

### CHECKING ENGINE COOLANT LEVEL

Check the coolant level in the reservoir tank when the engine is cold. If the coolant level is below MIN ②, add coolant up to the MAX ① level. If the reservoir tank is empty, check the coolant level in the radiator **when the engine is cold**. If there is insufficient coolant in the radiator, fill the radiator with coolant up to the filler opening and also add it to the reservoir tank up to the MAX level ①.

If the engine cooling system frequently requires coolant, have it checked by an INFINITI dealer.

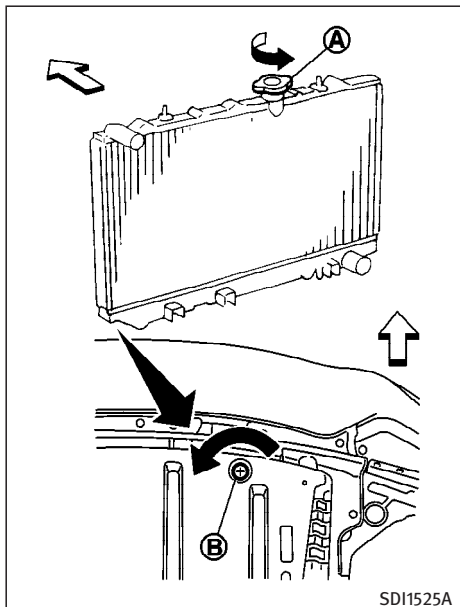

### VQ35DE CHANGING ENGINE COOLANT

- Major cooling system repairs should be performed by an INFINITI dealer. The service procedures can be found in the appropriate INFINITI Service Manual.

- Improper servicing can result in reduced heater performance and engine overheating.



### WARNING

- To avoid the danger of being scalded, never change the coolant when the engine is hot.
- Never remove the radiator cap when the engine is hot. Serious burns could be caused by high pressure fluid escaping from the radiator.
- Avoid direct skin contact with used coolant. If skin contact is made, wash thoroughly with soap or hand cleaner as soon as possible.
- Keep coolant out of the reach of children and pets.

### VQ35DE engine

1. Open radiator drain plug (B) at the bottom of radiator, and remove radiator filler cap (A).
- **Be careful not to allow coolant to contact drive belts.**

- **Waste coolant must be disposed of properly. Check your local regulations.**
2. Close the radiator drain plug **(B)** securely after the coolant is drained.
  3. Fill the radiator slowly with the proper mixture of anti-freeze solution and demineralized water/distilled water. Fill the reservoir tank up to the MAX level. Then install the radiator filler cap **(A)**.
  4. Start the engine and warm it up until it reaches normal operating temperature. Then race the engine 2 or 3 times under no load. Watch the engine coolant temperature gauge for signs of overheating.
  5. Stop the engine. After it completely cools down, refill the radiator up to the filler opening. Fill the reservoir tank up to the MAX level. Check the drain plug for any sign of leakage.
  6. Recheck the coolant level after the vehicle has been driven for a day.

### VK45DE engine

Contact an INFINITI dealer if replacement is required.

## ENGINE OIL

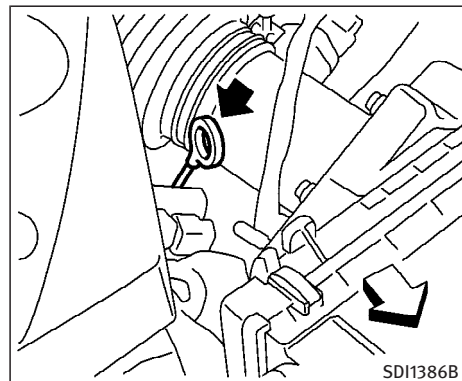

### VQ35DE CHECKING ENGINE OIL LEVEL

1. Park the vehicle on a level surface and apply parking brake.
2. Run the engine until it reaches operating temperature.
3. Turn off the engine. **Wait more than 15 minutes for the oil to drain back into the oil pan.**
4. Remove the dipstick and wipe it clean. Reinsert it all the way.

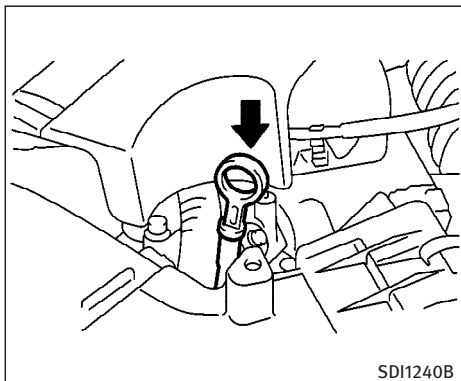

VK45DE

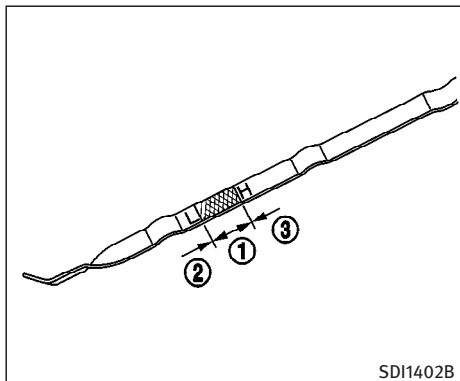

VQ35DE

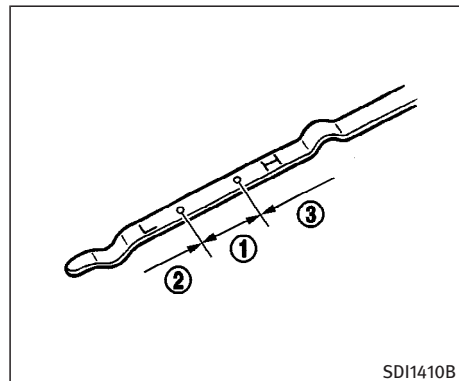

VK45DE

5. Remove the dipstick again and check the oil level. It should be between the H and L marks ①. If the oil level is below the L mark ②, remove the oil filler cap and pour recommended oil through the opening. **Do not overfill** ③.
6. Recheck oil level with dipstick.

**It is normal to add some oil between oil maintenance intervals or during the break-in period, depending on the severity of operating conditions.**



## CAUTION

**Oil level should be checked regularly. Operating the engine with an insufficient amount of oil can damage the engine, and such damage is not covered by warranty.**



## CHANGING ENGINE OIL AND FILTER

Change the engine oil and filter according to the maintenance intervals shown in the INFINITI Service and Maintenance Guide.

### Vehicle set-up

1. Park the vehicle on a level surface and apply the parking brake.
2. Run the engine until it reaches operating temperature.
3. Turn the engine off and wait more than 15 minutes.
4. Raise and support the vehicle using a suitable floor jack and safety jack stands.
  - Place the safety jack stands under the vehicle jack-up points.
  - A suitable adapter should be attached to the jack stand saddle.
5. Remove the plastic engine undercover.
  - a. Remove the small plastic clips at the rear side of the undercover.
  - b. Then remove the other bolts that hold the undercover in place.



### CAUTION

Use the correct jack-up points. Never use any other part of the vehicle for jack support.

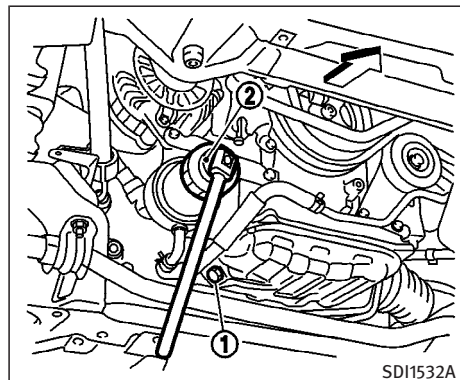

VQ35DE

### Engine oil and filter

1. Place a large drain pan under the drain plug ①.
2. Remove the oil filler cap.
3. Remove the drain plug ① with a wrench and completely drain the oil.



### CAUTION

Be careful not to burn yourself. The engine oil may be hot.

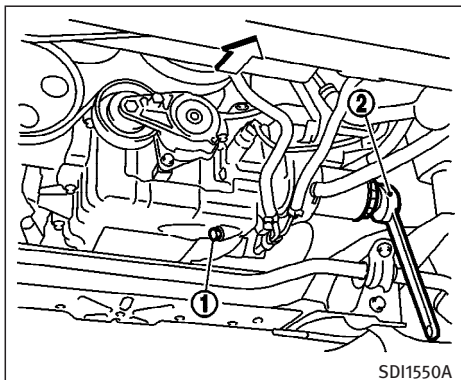

VK45DE

SDI1550A

- **Waste oil must be disposed of properly.**
  - **Check your local regulations.**
4. Loosen the oil filter with an oil filter wrench (2). Remove the oil filter by turning it by hand.
  5. Wipe the engine oil filter mounting surface with a clean rag.  
**Be sure to remove any old rubber gasket remaining on the mounting surface of the engine.**
  6. Coat the gasket on the new filter with clean engine oil.

## 8-14 Maintenance and do-it-yourself

7. Screw in the oil filter clockwise until a slight resistance is felt, then tighten additionally more than 2/3 turn.

### Oil filter tightening torque:

**11 to 15 ft-lb  
(14.7 to 20.5 N·m)**

8. Clean and re-install the drain plug (1) with a new washer. Securely tighten the drain plug (1) with a wrench.

### Drain plug tightening torque:

**22 to 29 ft-lb  
(29 to 39 N·m)**

Do not use excessive force.

9. Refill engine with recommended oil and install the cap securely.



## CAUTION

**The dipstick must be inserted in place to prevent oil spillage from the dipstick hole while filling the engine with oil.**

See “Capacities and recommended fuel/lubricants” in the “9. Technical and consumer information” section for drain and refill capacity. The drain and refill capacity depends on the oil tem-

perature and drain time. Use these specifications for reference only. Always use the dipstick to determine the proper amount of oil in the engine.



## CAUTION

**When filling oil, do not pull out the dipstick.**

10. Start the engine and check for leakage around the drain plug and the oil filter. Correct as required.
11. Turn the engine off and wait more than 10 minutes. Check the oil level with the dipstick. Add engine oil if necessary.

## After the operation

1. Install the engine undercover into position as the following steps.
  - a. Pull the center of the small plastic clip out.
  - b. Hold the engine undercover into position.
  - c. Insert the clips through the undercover into the hole in the frame, then push the center of the clip in to lock the clip in place.

- d. Install the other bolts that hold the undercover in place. Be careful not to strip the bolts or over-tighten them.
2. Lower the vehicle carefully to the ground.
3. Dispose of waste oil and filter properly.



## WARNING

- Prolonged and repeated contact with used engine oil may cause skin cancer.
- Try to avoid direct skin contact with used oil. If skin contact is made, wash thoroughly with soap or hand cleaner as soon as possible.
- Keep used engine oil out of reach of children.

## AUTOMATIC TRANSMISSION FLUID

If checking or replacement is required, we recommend an INFINITI dealer for servicing.



## CAUTION

- Use only Genuine NISSAN Matic J ATF. Do not mix with other fluids.
- Using automatic transmission fluid other than Genuine NISSAN Matic J ATF will cause deterioration in driveability and automatic transmission durability, and may damage the automatic transmission, which is not covered by the INFINITI new vehicle limited warranty.

The specified automatic transmission fluid is also described on caution labels located in the engine compartment.

## POWER STEERING FLUID

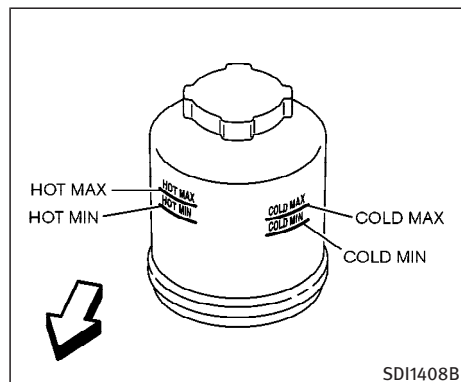

Check the fluid level in the reservoir.

The fluid level should be checked using the HOT range at fluid temperatures of 122 to 176°F (50 to 80°C) or using the COLD range at fluid temperatures of 32 to 86°F (0 to 30°C).



## CAUTION

- Do not overfill.
- Use Genuine NISSAN PSF or equivalent.

## BRAKE FLUID

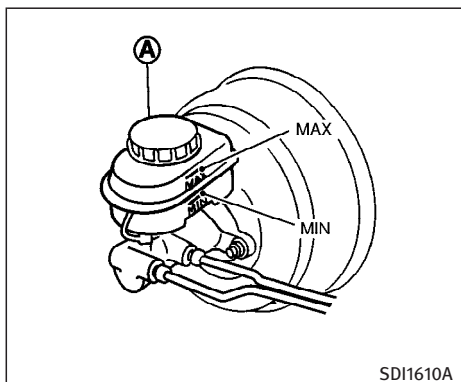

Check the fluid level in the brake fluid reservoir (A). If the fluid is below the MIN line or the brake warning light comes on, add Genuine NISSAN Super Heavy Duty Brake Fluid or equivalent to **DOT 3** fluid up to the MAX line. If fluid must be added frequently, the system should be thoroughly checked by an INFINITI dealer.



### WARNING

Use only new fluid. Old, inferior or contaminated fluid may damage the brake system.

Do not add synthetic brake fluid. The use of improper fluids can damage the brake system and affect the vehicle's stopping ability.



### CAUTION

Do not spill the fluid on any painted surfaces. This will damage the paint. If fluid is spilled, immediately wash the surface with water.

## WINDOW WASHER FLUID

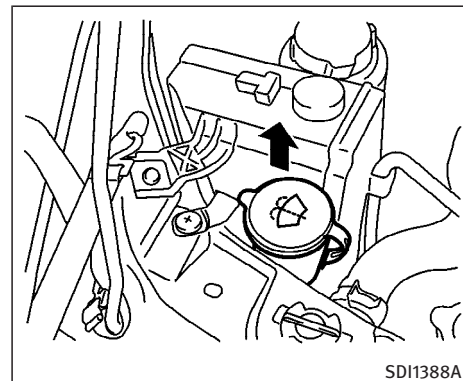

Add fluid when the low washer fluid warning light comes on. Add a washer solvent to the water for better cleaning. In the winter season, add a windshield washer anti-freeze. Follow the manufacturer's instructions for the mixture ratio.



## WARNING

Anti-freeze is poisonous and should be stored carefully in marked containers out of the reach of children.



## CAUTION

Do not substitute engine anti-freeze coolant for window washer solution. This may result in damage to the paint.

- Do not fill the window washer reservoir tank with washer fluid concentrates at full strength. Some methyl alcohol based washer fluid concentrates may permanently stain the grille if spilled while filling the window washer reservoir tank.

- Pre-mix washer fluid concentrates with water to the manufacturer's recommended levels before pouring the fluid into the window washer reservoir tank. Do not use the window washer reservoir tank to mix the washer fluid concentrate and water.

## BATTERY

- Keep the battery surface clean and dry. Any corrosion should be washed off with a solution of baking soda and water.
- Make certain the terminal connections are clean and securely tightened.
- If the vehicle is not to be used for 30 days or longer, disconnect the (–) negative battery terminal cable to prevent discharging it.



## WARNING

- Do not expose the battery to flames or electrical sparks. Hydrogen gas, generated by battery fluid, is explosive. Do not allow battery fluid to contact your skin, eyes, fabrics, or painted surfaces. After touching a battery or battery cap, do not touch or rub your eyes. Thoroughly wash your hands. If the acid contacts your eyes, skin or clothing, immediately flush with water for at least 15 minutes and seek medical attention.

- Do not operate the vehicle if the battery fluid is low. Low battery fluid can cause a higher load on the battery which can generate heat, reduce battery life, and in some cases lead to an explosion.
- When working on or near a battery, always wear suitable eye protection and remove all jewelry.
- Battery posts, terminals and related accessories contain lead and lead compounds. Wash hands after handling.
- Keep the battery out of the reach of children.

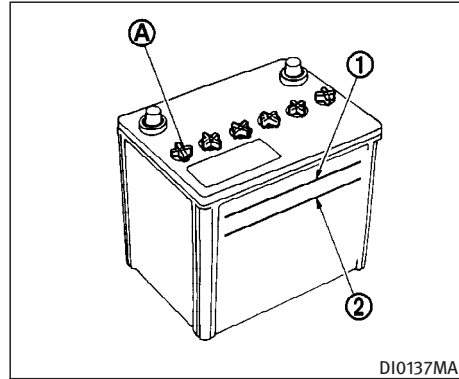

Check the fluid level in each cell. It should be between the UPPER LEVEL ① and LOWER LEVEL ② lines.

If it is necessary to add fluid, add only distilled water to bring the level to the indicator in each filler opening. **Do not overfill.**

Vehicles operated in high temperatures or under severe conditions require frequent checks of the battery fluid level.

1. Remove the cell plugs ①.
2. Add distilled water up to the UPPER LEVEL ① line.

3. Tighten cell plugs ①.

Vehicles operated in high temperatures or under severe conditions require frequent checks of the battery fluid level.

## DRIVE BELTS

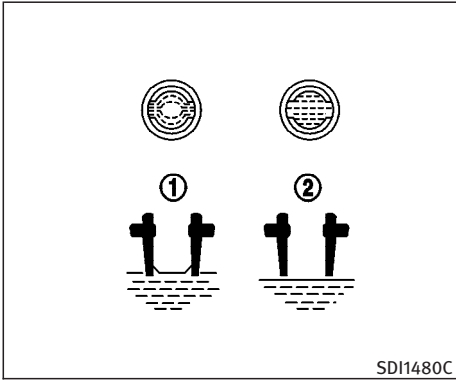

If the side of the battery is not visible, check the distilled water level by looking directly above the cell; ① indicates OK and ② needs more to be added.

### JUMP STARTING

If jump starting is necessary, see “Jump starting” in the “6. In case of emergency” section. If the engine does not start by jump starting, the battery may have to be replaced. Contact an INFINITI dealer.

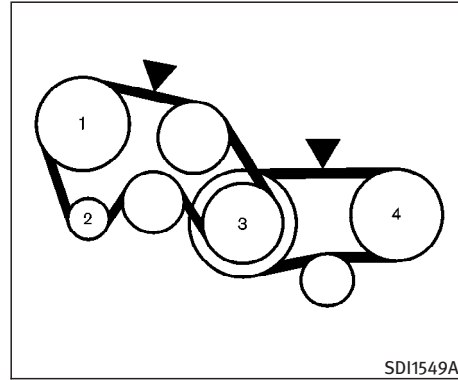

#### VQ35DE

1. Power steering fluid pump
  2. Alternator
  3. Crankshaft pulley
  4. Air conditioner compressor
- ▼: Tension checking points

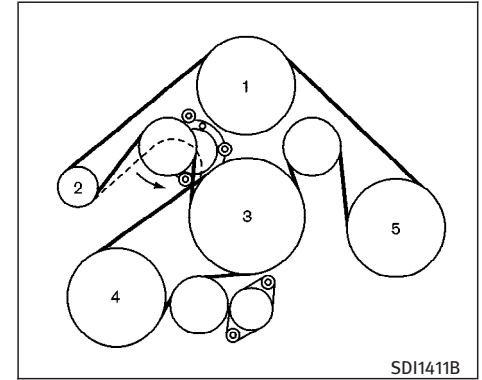

#### VK45DE

1. Water pump
2. Alternator
3. Crankshaft pulley
4. Power steering fluid pump
5. Air conditioner compressor

## SPARK PLUGS



### WARNING

Be sure the ignition key is in the OFF or LOCK position. The engine could rotate unexpectedly.



### WARNING

Be sure the engine and ignition switch are off and that the parking brake is engaged securely.



### CAUTION

Be sure to use the correct socket to remove the spark plugs. An incorrect socket can damage the spark plugs.

1. Visually inspect each belt for signs of unusual wear, cuts, fraying, oil adhesion or looseness. If the belt is in poor condition or loose, have it replaced or adjusted by an INFINITI dealer.
2. Have the belts checked regularly for condition and tension in accordance with the maintenance schedule in your “INFINITI Service and Maintenance Guide”.

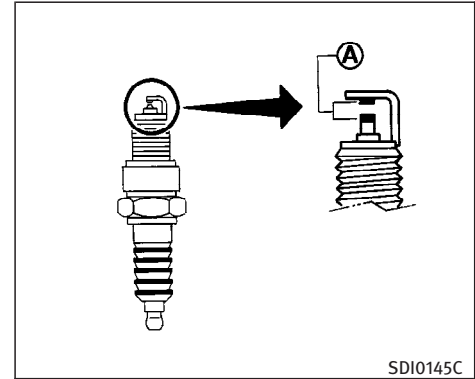

## REPLACING SPARK PLUGS

If replacement is required, see an INFINITI dealer for servicing.

### Platinum-tipped spark plugs

It is not necessary to replace the platinum-tipped (A) spark plugs as frequently as the conventional type spark plugs since they will last much longer. Follow the maintenance log in your “INFINITI Service and Maintenance Guide”, but do not reuse them by cleaning or regapping.

**Always replace with recommended platinum-tipped spark plugs.**



## AIR CLEANER

If maintenance is required, see an INFINITI dealer for servicing.

The filter element should not be cleaned and reused. Replace it according to the maintenance log shown in your “INFINITI Service and Maintenance Guide”. When replacing the filter, wipe the inside of the air cleaner housing and the cover with a damp cloth.



### WARNING

- **Operating the engine with the air cleaner removed can cause you or others to be burned. The air cleaner not only cleans the air, it stops the flame if the engine backfires. If it is not there, and the engine backfires, you could be burned. Do not drive with the air cleaner removed, and be careful when working on the engine with the air cleaner removed.**
- **Never pour fuel into the throttle body or attempt to start the engine with the air cleaner removed. Doing so could result in serious injury.**

## WINDSHIELD WIPER BLADES



### CAUTION

- **After wiper blade replacement, return the wiper arm to its original position; otherwise it may be damaged when the engine hood is opened.**
- **Make sure the wiper blades contact the glass; otherwise the arms may be damaged from wind pressure.**
- **Worn windshield wiper blades can damage the windshield and impair driver vision.**

## CLEANING

If your windshield is not clear after using the windshield washer or if a wiper blade chatters when running, wax or other material may be on the blade or windshield.

Clean the outside of the windshield with a washer solution or a mild detergent. Your windshield is clean if beads do not form when rinsing with clear water.

Clean the blade by wiping it with a cloth soaked in a washer solution or a mild detergent. Then rinse the blade with clear wa-

ter. If your windshield is still not clear after cleaning the blades and using the wiper, replace the blades.

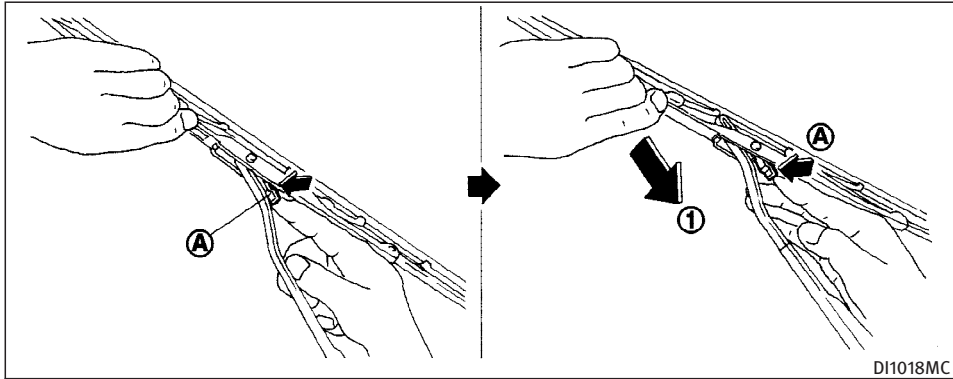

## REPLACING

Replace the wiper blades if they are worn.

1. Pull the wiper arm.
2. Push and hold the release tab (A), then move the wiper blade down the wiper arm to remove ①.
3. Insert the new wiper blade to the wiper arm until a click sounds.

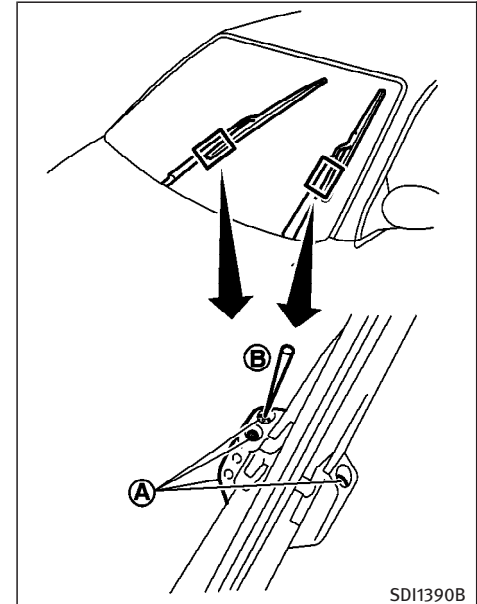

If necessary, clean the windshield washer nozzle (A) with a needle or small pin (B).

## REAR WINDOW WIPER BLADE

Contact an INFINITI dealer if checking or replacement is required.

## PARKING BRAKE AND BRAKE PEDAL

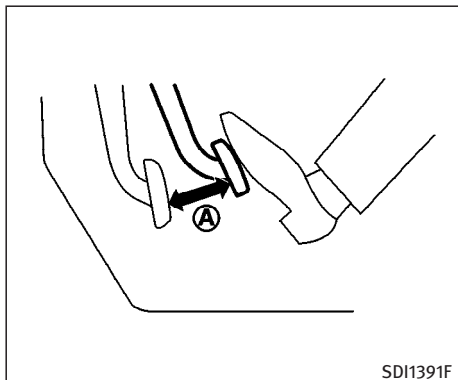

### CHECKING PARKING BRAKE

From the released position, depress the parking brake pedal slowly and firmly, and check the distance between the initial and final position of the pedal (A). If it is out of the range shown above, see an INFINITI dealer.

Range: 4 to 5 notches under a depressing force of 44 lb (196 N).

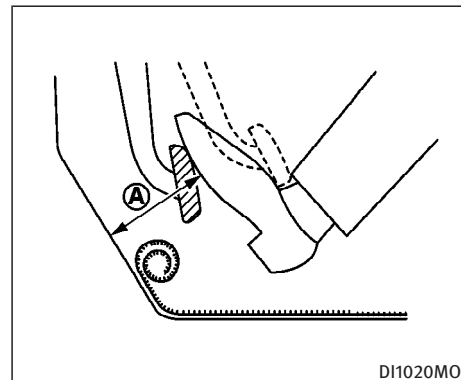

### CHECKING BRAKE PEDAL

With the engine running, check the distance between the upper surface of the pedal and the metal floor (A). If it is out of the range shown above, see an INFINITI dealer.

Range: 3.7 in (95 mm) or more under a depressing force of 110 lb (490 N).

### Self-adjusting brakes

Your vehicle is equipped with self-adjusting brakes.

The disc-type brakes self-adjust every time the brake pedal is applied.



## WARNING

See an INFINITI dealer for a brake system check if the brake pedal height does not return to normal.

### Brake pad wear indicators

The disc brake pads on your vehicle have audible wear indicators. When a brake pad requires replacement, it will make a high pitched scraping or screeching sound when the vehicle is in motion whether or not the brake pedal is depressed. Have the brakes checked as soon as possible if the wear indicator sound is heard.

Under some driving or climate conditions, occasional brake squeak, squeal or other noise may be heard. Occasional brake noise during light to moderate stops is normal and does not affect the function or performance of the brake system.

**Proper brake inspection intervals should be followed.** For additional information, see the appropriate maintenance log shown in your “INFINITI Service and Maintenance Guide”.

### 8-24 Maintenance and do-it-yourself

## BRAKE BOOSTER

Check the brake booster function as follows:

1. With the engine off, press and release the brake pedal several times. When brake pedal movement (distance of travel) remains the same from one pedal application to the next, continue on to the next step.
2. While depressing the brake pedal, start the engine. The pedal height should drop a little.
3. With the brake pedal depressed, stop the engine. Keeping the pedal depressed for about 30 seconds, the pedal height should not change.
4. Run the engine for one minute without depressing the brake pedal, then turn it off. Depress the brake pedal several times. The pedal travel distance will decrease gradually with each depression as the vacuum is released from the booster.

If the brakes do not operate properly, see an INFINITI dealer.

## FUSES

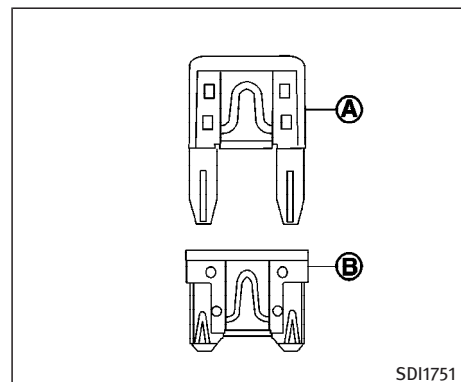

Two types of fuses are used. Type **A** is used in the fuse boxes in the engine compartment. Type **B** is used in the passenger compartment fuse box.

Type **A** fuses are provided as spare fuses. They are stored in the passenger compartment fuse box.

Type **A** fuses can be installed in the engine compartment and passenger compartment fuse boxes.

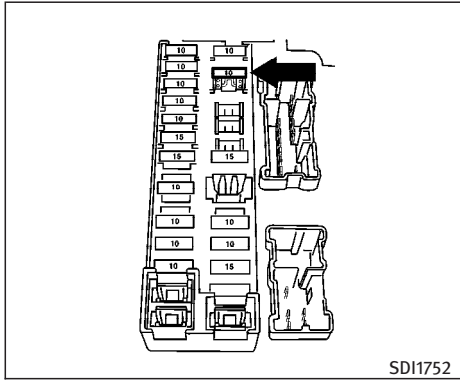

SDI1752

If a type **(A)** fuse is used to replace a type **(B)** fuse, the type **(A)** fuse will not be level with the fuse pocket as shown in the illustration. This will not affect the performance of the fuse. Make sure the fuse is installed in the fuse box securely.

Type **(B)** fuses cannot be installed in the underhood fuse boxes. Only use type **(A)** fuses in the underhood fuse boxes.

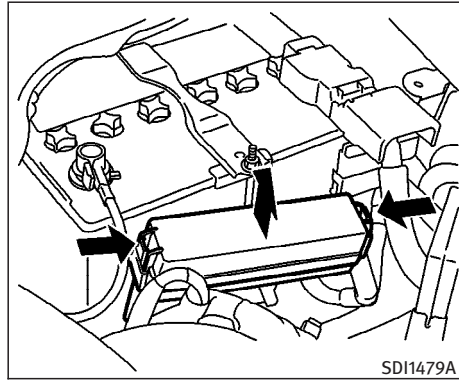

SDI1479A

2. Open the engine hood and remove the cover on the compartment of the battery and the fuse/fusible link holder.
3. Remove the fuse/fusible link holder cover by pushing the tab and lifting the cover up as illustrated.
4. Remove the fuse with the fuse puller. The fuse puller is located in the center of the fuse block in the passenger compartment.

## ENGINE COMPARTMENT



### CAUTION

**Never use a fuse of a higher or lower amperage rating than specified on the fuse box cover. This could damage the electrical system or cause a fire.**

If any electrical equipment does not operate, check for an open fuse.

1. Be sure the ignition switch and headlight switch are OFF.

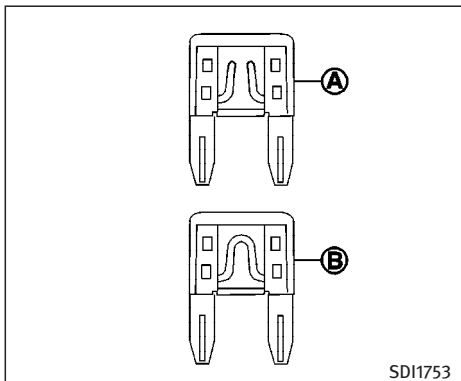

- If the fuse is open (A), replace it with a new fuse (B).
- If a new fuse also opens, have the electrical system checked and repaired by an INFINITI dealer.

### Fusible links

If the electrical equipment does not operate and the fuses are in good condition, check the fusible links. If any of these fusible links are melted, replace with only genuine NISSAN parts.

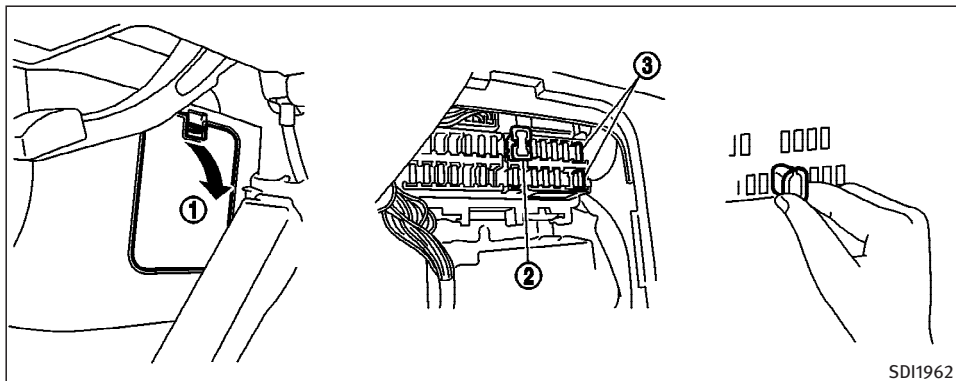

### PASSENGER COMPARTMENT



### CAUTION

Never use a fuse of a higher or lower amperage rating than specified on the fuse box cover. This could damage the electrical system or cause a fire.

If any electrical equipment does not operate, check for an open fuse.

- Be sure the ignition switch and the headlight switch are in the OFF position.
- Open the fuse box lid (1).
- Remove the fuse with the fuse puller (2).
- If the fuse is open (A), replace it with a new fuse (B). Spare fuses (3) are stored in the fuse box.
- If a new fuse also opens, have the electrical system checked and repaired by an INFINITI dealer.

## KEYFOB BATTERY REPLACEMENT

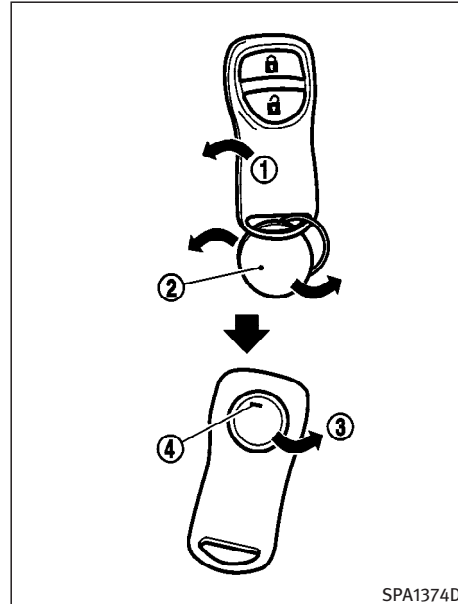
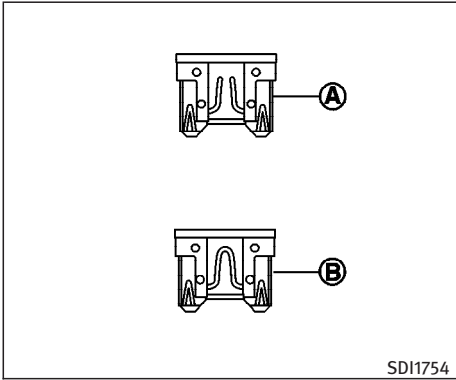

### KEYFOB (Except Intelligent Key)

Replace the battery as follows:

1. Open the lid ① using a suitable tool ②.

2. Replace the battery ③ with a new one. Set the battery with the “-” side ④ up. Recommended battery: CR2025 or equivalent

**Make sure that the ⊕ side faces the bottom case.**

3. Close the lid securely.
4. Push the keyfob button two or three times to check its operation.

See an INFINITI dealer if you need any assistance for replacement.

**If the battery is removed for any reason other than replacement, perform step 4 above.**

- Be careful not to touch the circuit board and the battery terminal.
- An improperly disposed battery can harm the environment. Always confirm local regulations for battery disposal.
- The keyfob is water-resistant; however, if it gets wet, immediately wipe it completely dry.
- When changing batteries, do not let dust or oil get on the keyfob.

### FCC Notice:

Changes or modifications not expressly approved by the party responsible for compliance could void the user's authority to operate the equipment. This device complies with Part 15 of the FCC Rules and RSS-210 of Industry Canada. Operation is subject to the following two conditions: (1) This device may not cause harmful interference, and (2) this device must accept any interference received, including interference that may cause undesired operation of the device.

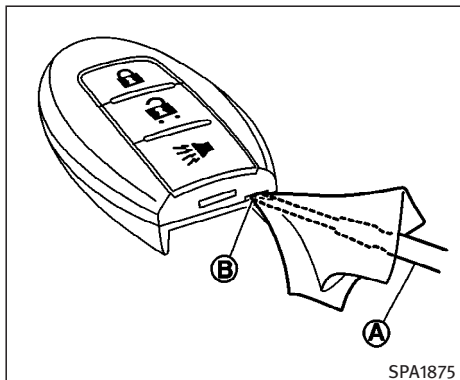

### INTELLIGENT KEY



### CAUTION

Be careful not to allow children to swallow the battery and removed parts.

Replace the battery as follows:

1. Release the lock knob at the back of the Intelligent Key and remove the mechanical key.
2. Insert a flat-blade screwdriver (A)

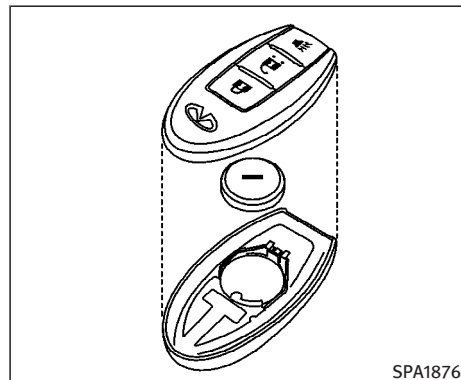

wrapped with a cloth into the slit (B) of the corner and twist it to separate the upper part from the lower part.

3. Replace the battery with a new one.

Recommended battery: CR2025 or equivalent

**Make sure that the ⊕ side faces the bottom of the case.**

4. Align the tips of the upper and lower parts, and then push them together until they are securely closed.



5. Push the buttons two or three times to check its operation.

See an INFINITI dealer if you need any assistance for replacement.

**If the battery is removed for any reason other than replacement, perform step 5 above.**

- **Be careful not to touch the circuit board and the battery terminal as it could cause a malfunction.**
- **An improperly disposed battery can harm the environment. Always confirm local regulations for battery disposal.**
- **When changing batteries, do not let dust or oil get on the Intelligent Key.**

**FCC Notice:**

**This equipment has been tested and found to comply with the limits for a Class B digital device pursuant to part 15 of the FCC Rules. These limits are designed to provide reasonable protection against harmful interference in a residential installation. This equipment generates, uses and can radiate radio frequency energy and, if not installed and used in accordance with the instructions, may cause harmful interference to radio communications. However,**

**there is no guarantee that interference will not occur in a particular installation. If this equipment does cause harmful interference to radio or television reception, which can be determined by turning the equipment off and on, the user is encouraged to try to correct the interference by one or more of the following measures:**

- **Reorient or relocate the receiving antenna**
- **Increase the separation between the equipment and the receiver**
- **Connect the equipment into an outlet on a circuit different from that to which the receiver is connected.**
- **Consult the dealer or an experienced radio/TV technician for help.**

## LIGHTS

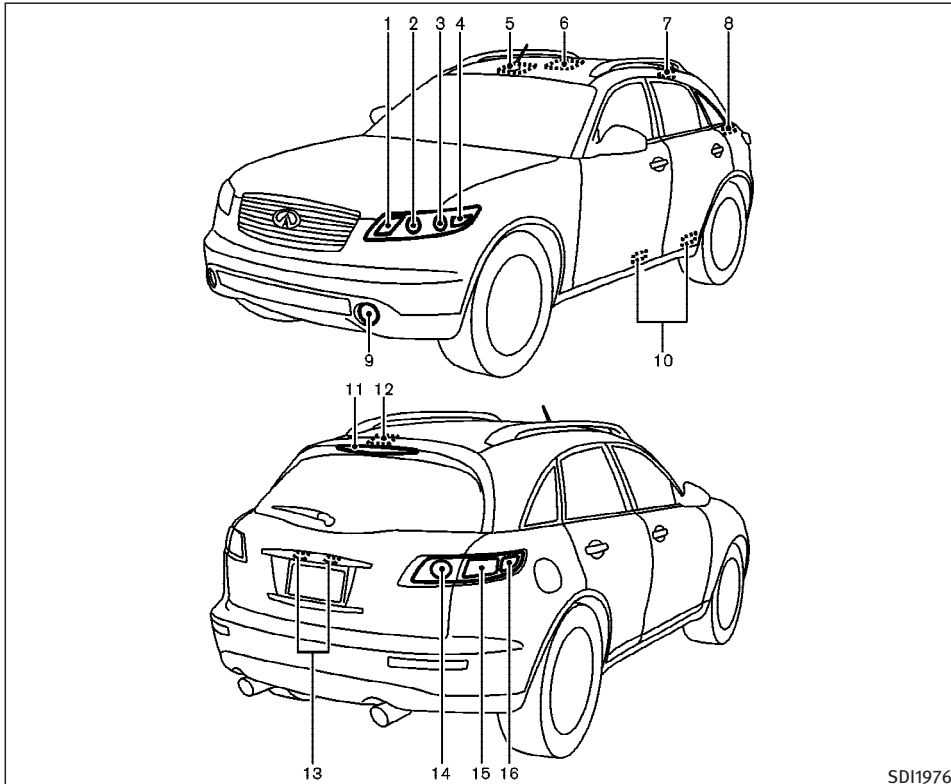

1. Clearance light/Daytime running light (Canada)
2. Headlight (low-beam, high-beam)
3. Front turn signal light
4. Front side marker light
5. Interior light/Map light
6. Ceiling light (if so equipped)
7. Rear personal light
8. Luggage light (side)
9. Front fog light
10. Step light
11. High-mounted stop light
12. Luggage light (roof)
13. License plate light
14. Back-up light
15. Tail/Stop/Turning signal lights
16. Rear side marker light

SDI1976

## HEADLIGHTS

### Replacing

If replacement is required, see an INFINITI dealer.

#### Xenon headlight bulb:



**WARNING**



**HIGH VOLTAGE**

**When xenon headlights are on, they produce a high voltage. To prevent an electric shock, never attempt to modify or disassemble. Always have your xenon headlights replaced at an INFINITI dealer. For additional information, see “Headlight and turn signal switch” in the “2. Instruments and controls” section.**

## EXTERIOR AND INTERIOR LIGHTS

Item	Wattage (W)	Bulb No.
Front turn signal	21	T20
Clearance/Daytime running light	5/21	T20
Front side marker light	3.8	T10
Front fog light*	35	H8
Rear combination light		
Tail/Stop/Turn signal lights*	(LED)	—
Side marker light	3.8	T10
Back-up light	18	T16
License plate light	5	T10
High-mounted stop light*	(LED)	—
Map light	8	—
Ceiling light (if so equipped)	8	—
Rear personal light	8	—
Step light*	5	—
Luggage (roof, side) light	8	—
Vanity mirror light (if so equipped)	1.32	—

\*: See an INFINITI dealer for replacement.

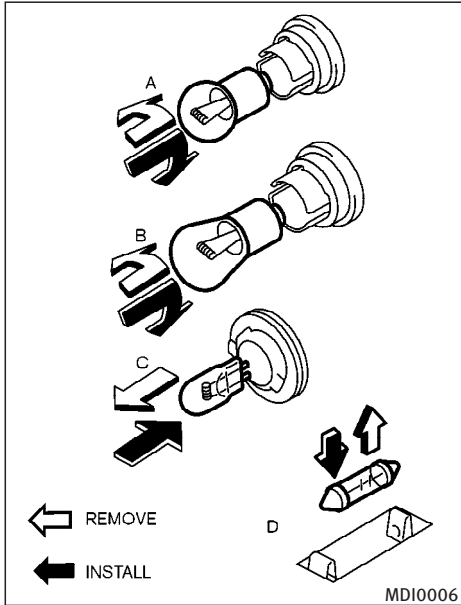

## Replacement procedures

All other lights are either type A, B, C or D. When replacing a bulb, first remove the lens and/or cover.

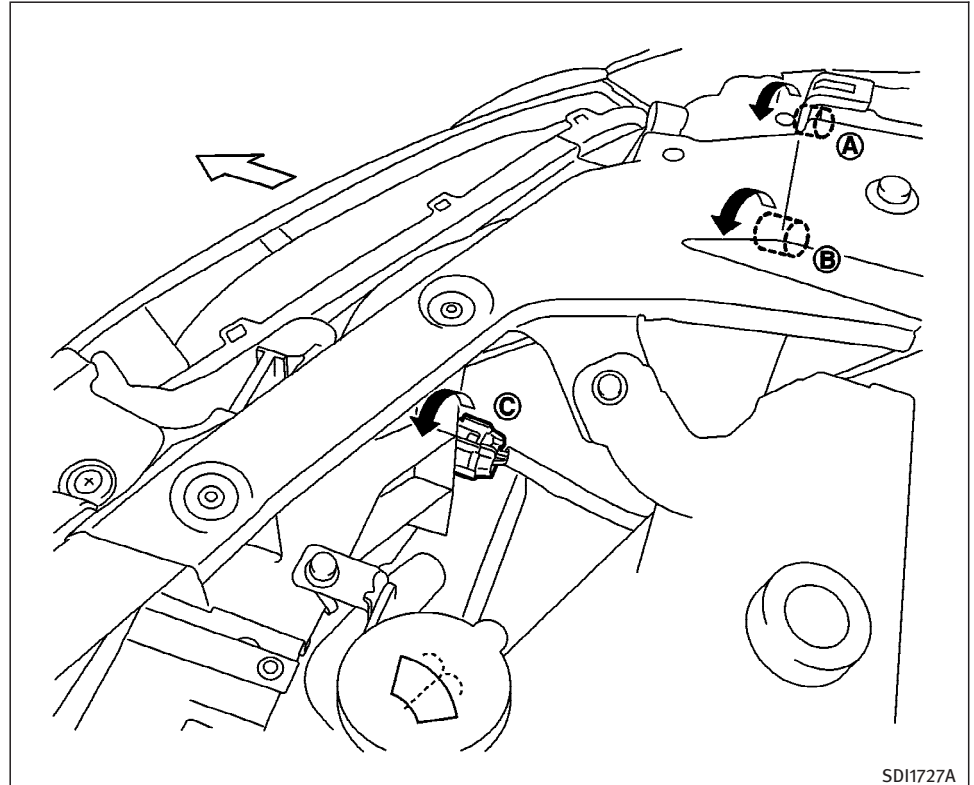

Ⓐ Front side marker light Ⓑ Front turn signal Ⓒ Clearance light

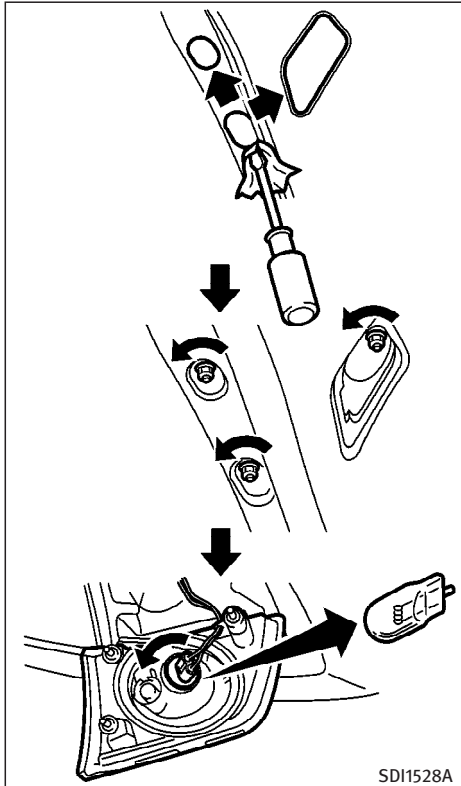

**Back-up light**

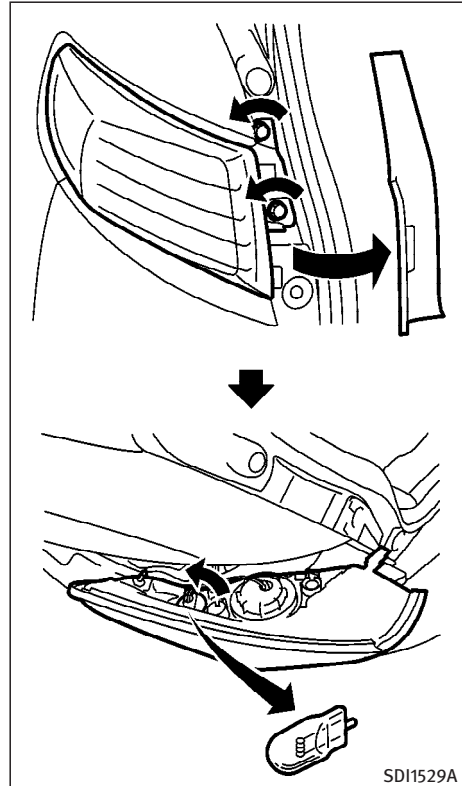

**Rear side marker light**

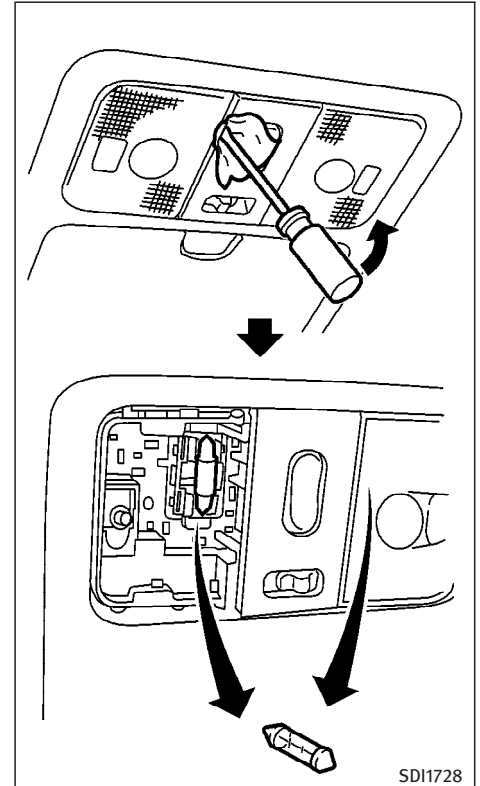

**Map light**  
Maintenance and do-it-yourself 8-33

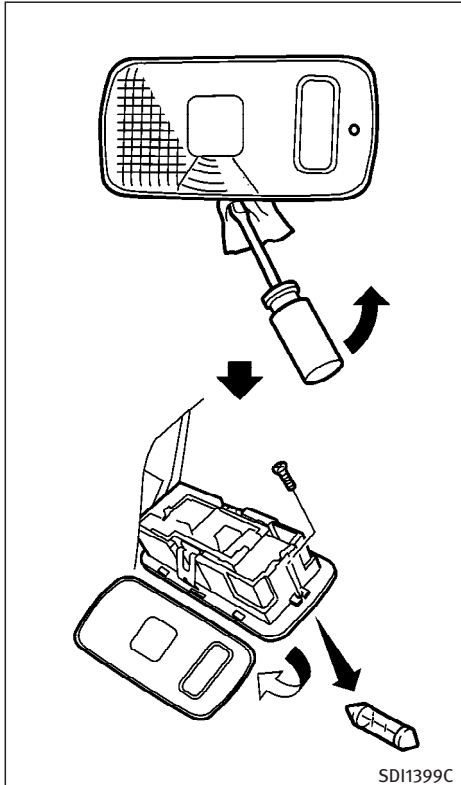

8-34 **Rear personal, Luggage light**  
Maintenance and do-it-yourself

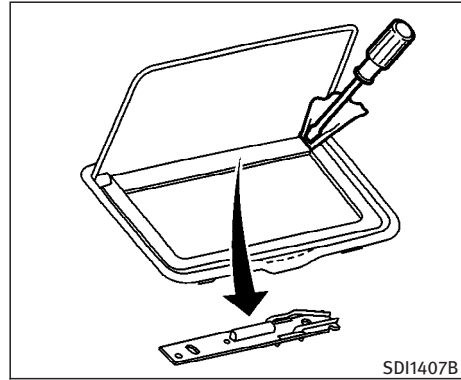

**Vanity mirror light**

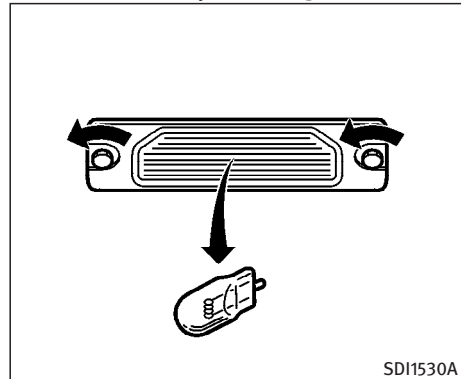

**License plate light**

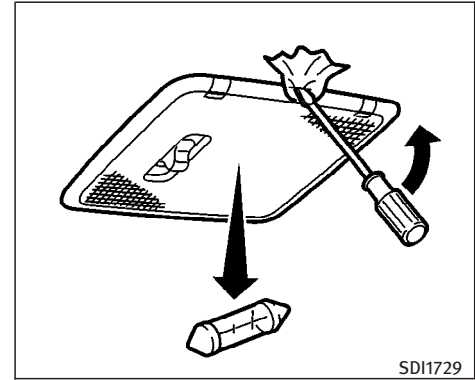

**Ceiling light (if so equipped)**

## WHEELS AND TIRES

If you have a flat tire, see “Flat tire” in the “6. In case of emergency” section.

### TIRE PRESSURE

#### Tire pressure monitoring system (TPMS)

This vehicle is equipped with the tire pressure monitoring system (TPMS). It monitors tire pressure of all tires except the spare. When the low tire pressure warning light is lit or flashing continuously, one or more of your tires is significantly under-inflated. If equipped, the system also displays pressure of all tires (except the spare tire) on the display screen by sending a signal from a sensor that is installed in each wheel.

The TPMS will activate only when the vehicle is driven at speeds above 16 MPH (25 km/h). Also, this system may not detect a sudden drop in tire pressure (for example a flat tire while driving).

For more details, refer to “Low tire pressure warning light” in the “2. Instruments and controls” section, “Tire pressure information” in the “4. Display screen, heater, air conditioner and audio systems” section, “Tire pressure monitoring system (TPMS)” in the “5. Starting and driving” section,

and “Flat tire” in the “6. In case of emergency” section.

#### Tire inflation pressure

Check the tire pressure (including the spare) often and always prior to long distance trips. The recommended tire pressure specifications are shown on the F.M.V.S.S./C.M.V.S.S. label or the Tire and Loading Information label (if so equipped) under the “Cold Tire Pressure” heading. The Tire and Loading Information label is affixed to the driver side center pillar. Tire pressures should be checked regularly because:

- Most tires naturally lose air over time.
- Tires can lose air suddenly when driven over potholes or other objects or if the vehicle strikes a curb while parking.

The tire pressures should be checked when the tires are cold. The tires are considered COLD after the vehicle has been parked for 3 or more hours, or driven less than 1 mile (1.6 km) at moderate speeds.

**Incorrect tire pressure, including under-inflation, may adversely affect tire life and vehicle handling.**



## WARNING

- **Improperly inflated tires can fail suddenly and cause an accident.**
- **The Gross Vehicle Weight rating (GVWR) is located on the F.M.V.S.S./C.M.V.S.S. label. The vehicle weight capacity is indicated on the Tire and Loading Information label (if so equipped). Do not load your vehicle beyond this capacity. Overloading your vehicle may result in reduced tire life, unsafe operating conditions due to premature tire failure, or unfavorable handling characteristics and could also lead to a serious accident. Loading beyond the specified capacity may also result in failure of other vehicle components.**
- **Before taking a long trip, or when ever you heavily load your vehicle, use a tire pressure gauge to ensure that the tire pressures are at the specified level.**

- Do not drive your vehicle over 85 MPH (137 km/h) unless it is equipped with high speed rated tires. Driving faster than 85 MPH (137 km/h) may result in tire failure, loss of control and possible injury.
- For additional information regarding tires, refer to “Important Tire Safety Information” (US) or “Tire Safety Information” (Canada) in the Warranty Information Booklet.

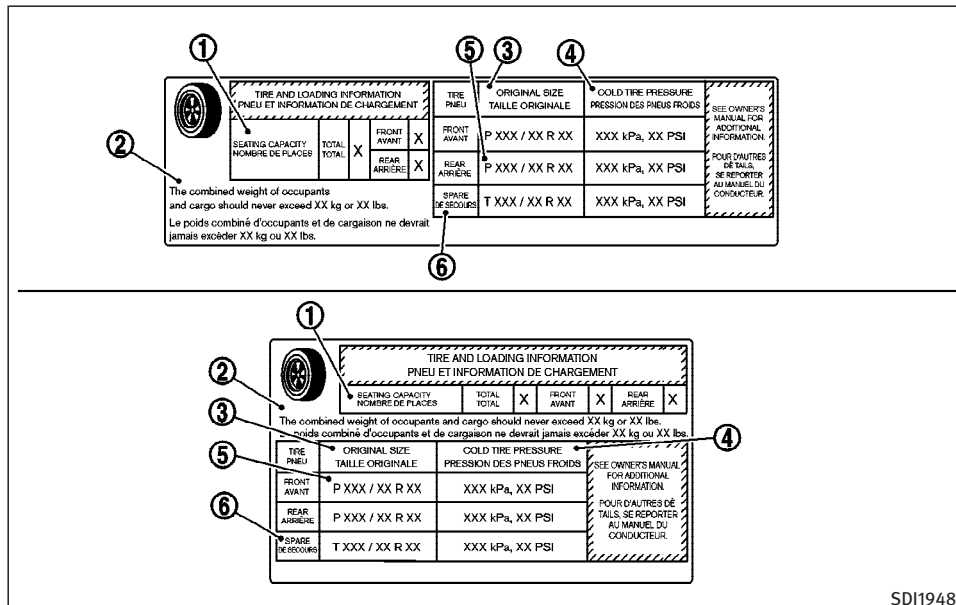

Tire and loading information label

① Seating capacity: The maximum number of occupants that can be seated in the vehicle.

② Vehicle load limit: See “loading information” in the “9. Technical and consumer information” section.

③ Original size: The size of the tires



originally installed on the vehicle at the factory.

- ④ Cold tire pressure: Inflate the tires to this pressure when the tires are cold. Tires are considered COLD after the vehicle has been parked for 3 or more hours, or driven less than 1 mile (1.6 km) at moderate speeds. The recommended cold tire inflation is set by the manufacturer to provide the best balance of tire wear, vehicle handling driveability, tire noise, etc., up to the vehicle's GVWR.
- ⑤ Tire size — refer to “Tire labeling” later in this section.
- ⑥ Spare tire size or compact spare tire size (if so equipped)

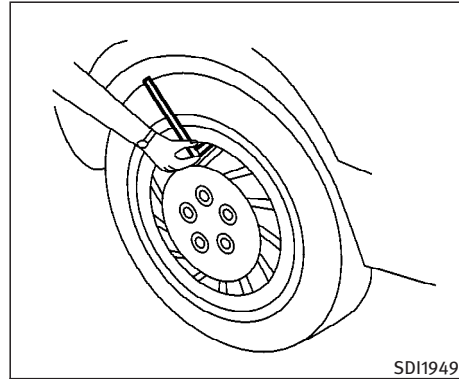

### Checking tire pressure

1. Remove the valve stem cap from the tire.
2. Press the pressure gauge squarely onto the valve stem. Do not press too hard or force the valve stem sideways, or air will escape. If the hissing sound of air escaping from the tire is heard while checking the pressure, reposition the gauge to eliminate this leakage.
3. Remove the gauge.

4. Read the tire pressure on the gauge stem and compare it to the specification shown on the Tire and Loading Information label.
5. Add air to the tire as needed. If too much air is added, press the core of the valve stem briefly with the tip of the gauge stem to release pressure. Recheck the pressure and add or release air as needed.
6. Install the valve stem cap.
7. Check the pressure of all other tires, including the spare.

	Size	Cold Tire Inflation Pressure
Front Original Tire	P265/60R18 P265/50R20	220 kPa, 32 psi
Rear Original Tire	P265/60R18 P265/50R20	220 kPa, 32 psi
Spare Tire	T175/90D18	420 kPa, 60 psi

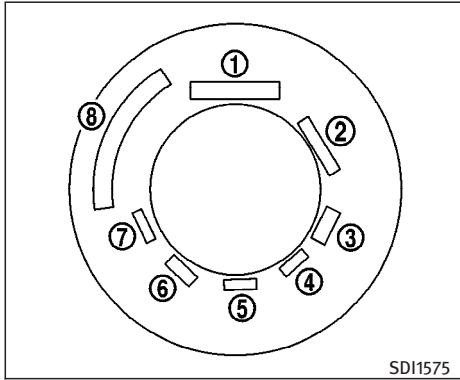

Example

SDI1575

## TIRE LABELING

Federal law requires tire manufacturers to place standardized information on the sidewall of all tires. This information identifies and describes the fundamental characteristics of the tire and also provides the tire identification number (TIN) for safety standard certification. The TIN can be used to identify the tire in case of a recall.

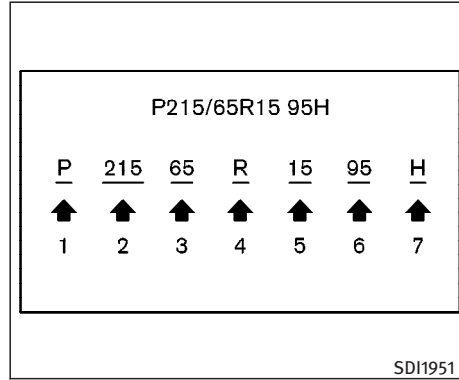

Example

SDI1951

### ① Tire size (example: P215/65R15 95H)

1. P: The “P” indicates the tire is designed for passenger vehicles (not all tires have this information).
2. Three-digit number (215): This number gives the width in millimeters of the tire from sidewall edge to sidewall edge.
3. Two-digit number (65): This number, known as the aspect ratio, gives the tire’s ratio of height to width.
4. R: The “R” stands for radial.

5. Two-digit number (15): This number is the wheel or rim diameter in inches.
6. Two- or three-digit number (95): This number is the tire’s load index. It is a measurement of how much weight each tire can support. You may not find this information on all tires because it is not required by law.
7. H: Tire speed Rating. You should not drive the vehicle faster than the tire speed rating.

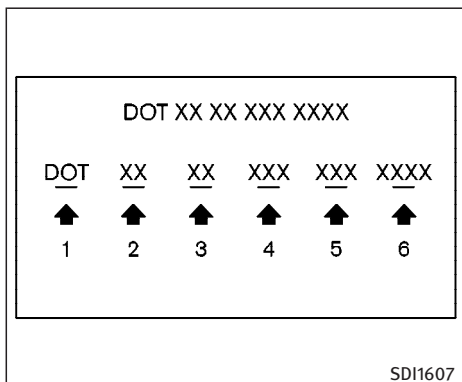

**Example**

② TIN (Tire Identification Number) for a new tire (example: DOT XX XX XXX XXXX)

1. DOT: Abbreviation for the “Department of Transportation”. The symbol can be placed above, below or to the left or right of Tire Identification Number.
2. Two-digit code: Manufacturer’s identification mark
3. Two-digit code: Tire size

4. Three-digit code: Tire type code (Optional)

5. Three-digit code: Date of Manufacture

6. Four numbers represent the week and year the tire was built. For example, the numbers 3103 means the 31st week of 2003. If these numbers are missing, then look on the other sidewall of the tire.

③ Tire ply composition and material  
The number of layers or plies of rubber-coated fabric in the tire. Tire manufacturers also must indicate the materials in the tire, which include steel, nylon, polyester, and others.

④ Maximum permissible inflation pressure  
This number is the greatest amount of air pressure that should be put in the tire. Do not exceed the maximum permissible inflation pressure.

⑤ Maximum load rating  
This number indicates the maximum load in kilograms and pounds that can be carried by the tire. When replacing the tires on the vehicle, al-

ways use a tire that has the same load rating as the factory installed tire.

⑥ Term of “tubeless” or “tube type”  
Indicates whether the tire requires an inner tube (“tube type”) or not (“tubeless”).

⑦ The word “radial”  
The word “radial” is shown if the tire has radial structure.

⑧ Manufacturer or brand name  
Manufacturer or brand name is shown.

**Other tire-related terminology:**

In addition to the many terms that are defined throughout this section, Intended Outboard Sidewall is (1) the sidewall that contains a whitewall, bears white lettering or bears manufacturer, brand and/or model name molding that is higher or deeper than the same molding on the other sidewall of the tire, or (2) the outward facing sidewall of an asymmetrical tire that has a particular side that must always face outward when mounted on a vehicle.

## TYPES OF TIRES



### WARNING

- **When changing or replacing tires, be sure all four tires are of the same type (Examples: Summer, All Season, or Snow and construction. An INFINITI dealer may be able to help you with information about tire type, size, speed rating and availability.**
- **Replacement tires may have a lower speed rating than the factory equipped tires, and may not match the potential maximum vehicle speed. Never exceed the maximum speed rating of the tire.**
- **Replacing tires with those not originally specified by INFINITI could affect the proper operation of the TPMS.**
- **For additional information regarding tires, refer to “Important Tire Safety Information” (US) or “Tire Safety Information” (Canada) in the Warranty Information Booklet.**

### All season tires

INFINITI specifies all season tires on some models to provide good performance for use all year around, including snowy and icy road conditions. All Season tires are identified by ALL SEASON and/or M&S on the tire sidewall. Snow tires have better snow traction than all season tires and may be more appropriate in some areas.

### Summer tires

INFINITI specifies summer tires on some models to provide superior performance on dry roads. Summer tire performance is substantially reduced in snow and ice. Summer tires do not have the tire traction rating M&S (Mud and Snow) on the tire sidewall.

If you plan to operate your vehicle in snowy or icy conditions, INFINITI recommends the use of snow or all season tires on all four wheels.

### Snow tires

If snow tires are needed, it is necessary to select tires equivalent in size and load rating to the original equipment tires. If you do not, it can adversely affect the safety and handling of your vehicle.

Generally, snow tires will have lower speed ratings than factory equipped tires and may not match the potential maximum vehicle speed. Never exceed the maximum speed rating of the tire.

If you operate your vehicle in snowy or icy conditions, INFINITI recommends the use of snow or all season tires on all four wheels.

For additional traction on icy roads, studded tires may be used. However, some provinces and states prohibit their use. Check local, state and provincial laws before installing studded tires. Skid and traction capabilities of studded snow tires, on wet or dry surfaces, may be poorer than that of non-studded snow tires.

### Run-flat tires (if so equipped)

If your vehicle is equipped with run-flat tires, you can continue driving to a safe location even if they are punctured. Always use run-flat tires of the same size on all four wheels. Mixing tire sizes or construction may reduce vehicle handling stability. If necessary, contact an INFINITI dealer for assistance.

- Frequently check the tire pressure information display on the monitor

screen and adjust pressure of each tire properly. (The order of the tire pressure figures displayed on the screen does not correspond with the actual order of the tire position.)

It can be difficult to tell if a run-flat tire is under-inflated or flat. Check the tire pressures as described earlier in this section. If the tire becomes under-inflated or flat while driving, the low tire pressure warning light will come on or flash continuously.

#### **Low tire pressure:**

If the vehicle is being driven with low tire pressure, the low tire pressure warning light will illuminate.

#### **Flat tire:**

If the vehicle is being driven with one or more flat tires, the low tire pressure warning light will flash continuously and a chime will sound for 10 seconds.

The chime will only sound at the first indication of a flat tire and the warning light will flash continuously. When the Flat tire warning is activated, have the system reset and the tire checked and replaced if necessary by an INFINITI dealer. Even if the tire is inflated to the specified COLD tire pressure, the warning light will continue to

flash until the system is reset by an INFINITI dealer.

If the low tire pressure warning light comes on:

- Do not exceed 55 MPH (88 km/h).
- Increase your following distance to allow for increased stopping distances.
- Avoid sudden maneuvers, hard cornering and hard braking.
- Do not tow a trailer.



### **WARNING**

- Although you can continue driving with a punctured run-flat tire, remember that vehicle handling stability is reduced, which could lead to an accident and personal injury. Also, driving a long distance at high speeds may damage the tire.

- Do not drive at speeds above 55 MPH (88 km/h) and do not drive more than 50 miles (80 km) with a punctured run-flat tire (if so equipped). The actual distance the vehicle can be driven on a flat tire depends on outside temperature, vehicle load, road conditions and other factors.
- Drive safely at reduced speeds. Avoid hard cornering or braking, which may cause you to lose control of the vehicle.
- Do not tow a trailer when a run-flat tire is flat.



### **CAUTION**

- Never install tire chains on a punctured run-flat tire, as this could damage your vehicle.
- Avoid driving over any projection or pothole, as the clearance between the vehicle and the ground is smaller than normal.

- Do not enter an automated car wash with a punctured run-flat tire.
- Have the punctured tire replaced by an INFINITI dealer as soon as possible, as the tire's performance capability is reduced.

## All-wheel drive (AWD) models



### CAUTION

- Always use tires of the same type, size, brand, construction (bias, bias-belted or radial), and tread pattern on all four wheels. Failure to do so may result in a circumference difference between tires on the front and rear axles which will cause excessive tire wear and may damage the transmission, transfer case and differential gears.
- ONLY use spare tires specified for the AWD model.

If excessive tire wear is found, it is recommended that all four tires be replaced with

tires of the same size, brand, construction and tread pattern. The tire pressure and wheel alignment should also be checked and corrected as necessary. Contact an INFINITI dealer.

**Tire chains must be installed only on the rear wheels and not on the front wheels.**

Do not drive with tire chains on paved roads which are clear of snow. Driving with chains in such conditions can cause damage to the various mechanisms of the vehicle due to some overstress.

## TIRE CHAINS

Use of tire chains may be prohibited according to location. Check the local laws before installing tire chains. When installing tire chains, make sure they are of proper size for the tires on your vehicle and are installed according to the chain manufacturer instructions. **Use only SAE class S chains.** Class "S" chains are used on vehicles with restricted tire to vehicle clearance. Vehicles that can use Class "S" chains are designed to meet the SAE standard minimum clearances between the tire and the closest vehicle suspension or body component required to accommodate the use of a winter traction device (tire chains or cables). The minimum clearances are de-

termined using the factory equipped tire size. Other types may damage your vehicle. Use chain tensioners when recommended by the tire chain manufacturer to ensure a tight fit. Loose end links of the tire chain must be secured or removed to prevent the possibility of whipping action damage to the fenders or undercarriage. If possible, avoid fully loading your vehicle when using tire chains. In addition, drive at a reduced speed. Otherwise, your vehicle may be damaged and/or vehicle handling and performance may be adversely affected.

**Tire chains must be installed only on the rear wheels and not on the front wheels.**



### CAUTION

- Do not use tire chains on dry roads.
- Never install tire chains on a T-type spare tire or a punctured run-flat tire, as this could damage your vehicle.

Do not drive with tire chains on paved roads that are clear of snow. Driving with chains in such conditions can cause damage to the various mechanisms of the vehicle due to some overstress.

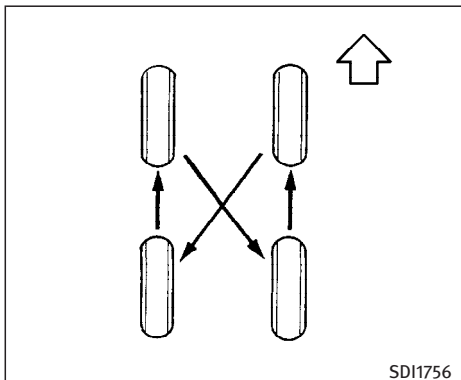

## CHANGING WHEELS AND TIRES

### Tire rotation

INFINITI recommends rotating the tires every 7,500 miles (12,000 km).

See “Flat tire” in the “6. In case of emergency” section of this manual for tire replacing procedures.

As soon as possible, tighten the wheel nuts to the specified torque with a torque wrench.

**Wheel nut tightening torque:  
80 ft-lb (108 N·m)**

The wheel nuts must be kept tightened to specifications at all times. It is recommended that wheel nuts be tightened to specification at each tire rotation interval.



## WARNING

- After rotating the tires, check and adjust the tire pressure.
- Retighten the wheel nuts when the vehicle has been driven for 600 miles (1,000 km) (also in cases of a flat tire, etc.).
- Do not include the spare tire in the tire rotation.
- For additional information regarding tires, refer to “Important Tire Safety Information” (US) or “Tire Safety Information” (Canada) in the Warranty Information Booklet.

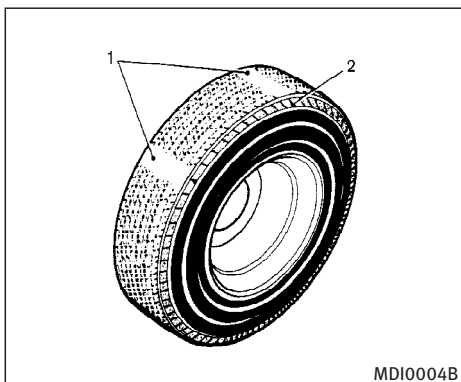

MDI0004B

1. Wear indicator
2. Location mark

### Tire wear and damage



### WARNING

- Tires should be periodically inspected for wear, cracking, bulging or objects caught in the tread. If excessive wear, cracks, bulging or deep cuts are found, the tire(s) should be replaced.

- The original tires have built-in tread wear indicators. When the wear indicators are visible, the tire(s) should be replaced.
- Tires degrade with age and use. Have tires, including the spare, over 6 years old checked by a qualified technician because some tire damage may not be obvious. Replace the tires as necessary to prevent tire failure and possible personal injury.
- Improper service of the spare tire may result in serious personal injury. If it is necessary to repair the spare tire, contact an INFINITI dealer.
- For additional information regarding tires, refer to “Important Tire Safety Information” (US) or “Tire Safety Information” (Canada) in the Warranty Information Booklet.

### Replacing wheels and tires

When replacing a tire, use the same size, speed rating and load carrying capacity as

originally equipped. See “Specifications” in the “9. Technical and consumer information” section for recommended types and sizes of tires and wheels.



### WARNING

- The use of tires other than those recommended or the mixed use of tires of different brands, construction (bias, bias-belted, radial or run-flat), or tread patterns can adversely affect the ride, braking, handling, ground clearance, body-to-tire clearance, tire chain clearance, speedometer calibration, headlight aim and bumper height. Some of these effects may lead to accidents and could result in serious personal injury.
- If the wheels are changed for any reason, always replace with wheels which have the same off-set dimension. Wheels of a different off-set could cause premature tire wear, degrade vehicle handling characteristics and/or interference with the brake discs. Such interference can lead to decreased braking effi-



ciency and/or early brake pad wear. Refer to “Wheels and tires” in the “9. Technical and consumer information” section of this manual for wheel off-set dimensions.

- When a spare tire is mounted or a wheel is replaced, tire pressure will not be indicated, the TPMS will not function and the low tire pressure warning light will flash. Contact your INFINITI dealer as soon as possible for tire replacement and/or system resetting.
- Replacing tires with those not originally specified by INFINITI could affect the proper operation of the TPMS.
- Do not install a deformed wheel or tire even if it has been repaired. Such wheels or tires could have structural damage and could fail without warning.
- The use of retread tires is not recommended.
- For additional information regarding tires, refer to “Important Tire Safety Information” (US) or “Tire Safety Informa-

tion” (Canada) in the Warranty Information Booklet.



## CAUTION

Always use tires of the same type, size, brand, construction (bias, bias-belted, radial or run-flat), and tread pattern on all four wheels. Failure to do so may result in a circumference difference between tires on the front and rear axles which will cause excessive tire wear and may damage the transmission, transfer case and differential gears (AWD models).

## Wheel balance

Unbalanced wheels may affect vehicle handling and tire life. Even with regular use, wheels can get out of balance. Therefore, they should be balanced as required.

Wheel balance service should be performed with the wheels off the vehicle. Spin balancing the rear wheels on the vehicle could lead to mechanical damage.

For additional information regarding tires, refer to “Important Tire Safety Information” (US) or “Tire Safety Information” (Canada) in the INFINITI Warranty Information Booklet.

## Care of wheels

- Wash the wheels when washing the vehicle to maintain their appearance.
- Clean the inner side of the wheels when the wheel is changed or the underside of the vehicle is washed.
- Do not use abrasive cleaners when washing the wheels.
- Inspect wheel rims regularly for dents or corrosion. Such damage may cause loss of pressure or poor seal at the tire bead.
- INFINITI recommends that the side walls of road wheels be waxed to protect against road salt in areas where it is used during winter.

## Spare tire (TEMPORARY USE ONLY spare tire (T-type))

Observe the following precautions if the T-type spare tire must be used, otherwise

your vehicle could be damaged or involved in an accident.



## CAUTION

- The T-type spare tire should be used for emergency use only. It should be replaced with the standard tire at the first opportunity to avoid possible tire or differential damage.
- Drive carefully while the T-type spare tire is installed. Avoid sharp turns and abrupt braking while driving.
- Periodically check the T-type spare tire inflation pressure, and always keep it at 60 psi (420 kPa, 4.2 bar).
- Always keep the pressure of the full size spare tire (if so equipped) at the recommended pressure for standard tires, as indicated on the Tire and Loading Information label. For the label location, see “Tire and Loading Information label” in the “9. Technical and consumer information”.

- Do not drive your vehicle at speeds faster than 50 MPH (80 km/h).
- Do not use tire chains on a T-type spare tire. Tire chains will not fit properly and may cause damage to the vehicle.
- When driving on roads covered with snow or ice, the T-type spare tire should be used on the front wheel and the original tire used on the rear wheels (drive wheels). Use tire chains only on the two rear original tires.
- Tire tread of the T-type spare tire will wear at a faster rate than the original tire. Replace the T-type spare tire as soon as the tread wear indicators appear.
- Because the T-type spare tire is smaller than the original tire, ground clearance is reduced. To avoid damage to the vehicle do not drive over obstacles. Also do not drive the vehicle through an automatic car wash since it may get caught.
- Do not use the T-type spare tire on other vehicles.

- Do not use more than one T-type spare tire at the same time.
- Do not tow a trailer while the T-type spare tire is installed.

# 9 Technical and consumer information

Capacities and recommended fuel/lubricants ....	9-2	Installing front license plate .....	9-14
Fuel recommendation .....	9-3	Vehicle loading information .....	9-15
Engine oil and oil filter recommendation.....	9-5	Terms.....	9-15
Recommended SAE viscosity number .....	9-6	Vehicle load capacity.....	9-16
Air conditioning system refrigerant and lubricant recommendations .....	9-6	Loading tips .....	9-18
Specifications.....	9-8	Measurement of weights.....	9-18
Engine.....	9-8	Towing a trailer .....	9-19
Wheels and tires.....	9-10	Maximum load limits .....	9-19
Dimensions and weights.....	9-10	Towing load/specification chart .....	9-21
When traveling or registering your vehicle in another country .....	9-11	Towing safety .....	9-21
Vehicle identification .....	9-11	Flat towing .....	9-24
Vehicle identification number (VIN) plate ...	9-11	Uniform tire quality grading.....	9-25
Vehicle identification number (Chassis number) .....	9-11	Emission control system warranty .....	9-26
Engine serial number .....	9-12	Reporting safety defects (US only) .....	9-26
F.M.V.S.S./C.M.V.S.S. certification label.....	9-12	Readiness for inspection/maintenance (I/M) test (US only) .....	9-27
Emission control information label .....	9-13	Event data recorders .....	9-28
Tire and loading information label.....	9-13	Owner's Manual/Service Manual order information.....	9-29
Air conditioner specification label .....	9-13	In the event of a collision.....	9-29

## CAPACITIES AND RECOMMENDED FUEL/LUBRICANTS

The following are approximate capacities. The actual refill capacities may be a little different. When refilling, follow the procedure instructed in the “8. Maintenance and do-it-yourself” section to determine the proper refill capacity.

	Capacity (Approximate)			Recommended specifications	
	US measure	Imp measure	Liter		
Fuel	23-3/4 gal	19-3/4 gal	90	Unleaded gasoline with an octane rating of at least 91 AKI (RON 96)*1	
Engine oil (Drain and refill)*6					
With oil filter change	VK45DE	6-1/8 qt	5-1/8 qt	5.8	For VK45DE engine • API Certification Mark*2, *3 • API grade SJ or SL, Energy Conserving*2, *3 • ILSAC grade GF-II & GF-III*2, *3
	VQ35DE	5 qt	4-1/8 qt		
Without oil filter change	VK45DE	5-1/2 qt	4-5/8 qt	5.2	For VQ35DE engine • API Certification Mark*2, *3 • API grade SG/SH, Energy Conserving I & II or API grade SJ or SL, Energy Conserving*3 • ILSAC grade GF-I, GF-II & GF-III*3
	VQ35DE	4-5/8 qt	3-7/8 qt		
Cooling system					
With reservoir	VK45DE	10-5/8 qt	8-3/4 qt	10.0	Genuine NISSAN Long Life Antifreeze/Coolant or equivalent
	VQ35DE	9-1/8 qt	7-5/8 qt		
Reservoir	VK45DE	7/8 qt	3/4 qt	0.8	
	VQ35DE	7/8 qt	3/4 qt		
Automatic transmission fluid	—	—	—	—	Genuine NISSAN Matic J ATF*4
Differential gear oil	—	—	—	—	API GL-5 Viscosity SAE 80W-90*7
Transfer fluid	—	—	—	—	Genuine NISSAN Matic D ATF (Continental U.S. and Alaska) or Canada NISSAN Automatic Transmission Fluid*8
Power steering fluid (PSF)	—	—	—	—	Genuine NISSAN PSF or equivalent*10
Brake fluid	—	—	—	—	Genuine NISSAN Super Heavy Duty Brake Fluid*5 or equivalent DOT 3
Multi-purpose grease	—	—	—	—	NLGI No. 2 (Lithium soap base)
Air conditioning system refrigerant	—	—	—	—	HFC-134a (R-134a)*9
Air conditioning system lubricants	—	—	—	—	NISSAN A/C System Oil Type S or exact equivalent
Windshield washer fluid	—	—	—	—	Genuine NISSAN Windshield Washer Concentrate Cleaner & Antifreeze or equivalent

\*1: For additional information, see “Fuel recommendation” later in this section.

\*2: For additional information, see “Engine oil and oil filter recommendation” later in this section.

\*3: For additional information, see “Recommended SAE viscosity number” later in this section.

\*4: **Using automatic transmission fluid other than Genuine NISSAN Matic J ATF will cause deterioration in driveability and automatic transmission durability, and may damage the automatic transmission, which is not covered by the INFINITI new vehicle limited warranty.**

\*5: Available in mainland US through an INFINITI dealer.

\*6: For additional information, see “Engine oil” in the “8. Maintenance and do-it-yourself” section for changing engine oil.

\*7: For hot climates, viscosity SAE 90 is suitable for ambient temperatures above 32°F (0°C).

\*8: DEXRON™III/MERCON™ or equivalent may also be used. Outside the continental United States and Alaska contact an INFINITI dealer for more information regarding suitable fluids, including recommended brand(s) of DEXRON™III/MERCON™ automatic transmission fluid.

\*9: For additional information, see “Vehicle identification” later in this section for air conditioner specification label.

\*10: For Canada, NISSAN Automatic Transmission Fluid (ATF), DEXRON™III/MERCON™ or equivalent ATF may also be used.

## 9-2 Technical and consumer information

## FUEL RECOMMENDATION

### VK45DE engine

In order to maintain engine and exhaust system durability and performance, unleaded premium gasoline with an octane rating of at least 91 AKI (Anti-Knock Index) number (Research octane number 96) must be used.

If premium gasoline is not available, unleaded regular gasoline with an octane rating of 87 AKI number (Research octane number 91) may be temporarily used, but only under the following precautions:

- Have the fuel tank filled only partially with unleaded regular gasoline, and fill up with unleaded premium gasoline as soon as possible.
- Avoid full throttle driving and abrupt acceleration.

### VQ35DE engine

Use unleaded regular gasoline with an octane rating of at least 87 AKI (Anti-Knock Index) number (Research octane number 91).

For improved vehicle performance, INFINITI recommends the use of unleaded

premium gasoline with an octane rating of at least 91 AKI number (Research octane number 96).



### CAUTION

- **Using a fuel other than that specified could adversely affect the emission control system, and may also affect the warranty coverage.**
- **Under no circumstances should a leaded gasoline be used, because this will damage the three-way catalyst.**
- **Do not use E-85 fuel in your vehicle. Your vehicle is not designed to run on E-85 fuel. Using E-85 fuel can damage the fuel system components and is not covered by the INFINITI vehicle limited warranty.**

### Gasoline specifications

INFINITI recommends using gasoline that meets the World-Wide Fuel Charter (WWFC) specifications where it is available. Many of the automobile manufacturers developed this specification to improve emission system and vehicle performance. Ask

your service station manager if the gasoline meets the WWFC specifications.

### Reformulated gasoline

Some fuel suppliers are now producing reformulated gasolines. These gasolines are specially designed to reduce vehicle emissions. INFINITI supports efforts towards cleaner air and suggests that you use reformulated gasoline when available.

### Gasoline containing oxygenates

Some fuel suppliers sell gasoline containing oxygenates such as ethanol, MTBE and methanol with or without advertising their presence. INFINITI does not recommend the use of fuels of which the oxygenate content and the fuel compatibility for your INFINITI cannot be readily determined. If in doubt, ask your service station manager.

If you use oxygenate-blend gasoline, please take the following precautions as the usage of such fuels may cause vehicle performance problems and/or fuel system damage.

- **The fuel should be unleaded and have an octane rating no lower than that recommended for unleaded gasoline.**

- If an oxygenate-blend, excepting a methanol blend, is used, it should contain no more than 10% oxygenate. (MTBE may, however, be added up to 15%.)
- If a methanol blend is used, it should contain no more than 5% methanol (methyl alcohol, wood alcohol). It should also contain a suitable amount of appropriate cosolvents and corrosion inhibitors. If not properly formulated with appropriate cosolvents and corrosion inhibitors, such methanol blends may cause fuel system damage and/or vehicle performance problems. At this time, sufficient data is not available to ensure that all methanol blends are suitable for use in INFINITI vehicles.

If any undesirable driveability problems such as engine stalling and hard hot starting are experienced after using oxygenate-blend fuels, immediately change to a non-oxygenate fuel or a fuel with a low blend of MTBE.

**Take care not to spill gasoline during refueling. Gasoline containing oxygenates can cause paint damage.**

## E-85 fuel

E-85 fuel is a mixture of approximately 85% fuel ethanol and 15% unleaded gasoline. E-85 can only be used in a Flexible Fuel Vehicle (FFV). Do not use E-85 fuel in your vehicle. U.S. government regulations require fuel ethanol dispensing pumps to be identified by a small, square, orange and black label with the common abbreviation or the appropriate percentage for that region.

## Aftermarket fuel additives

INFINITI does not recommend the use of any fuel additives (i.e. fuel injector cleaner, octane booster, intake valve deposit removers, etc.) which are sold commercially. Many of these additives intended for gum, varnish or deposit removal may contain active solvent or similar ingredients that can be harmful to the fuel system and engine.

## Octane rating tips

**Using unleaded gasoline with an octane rating lower than recommended can cause persistent, heavy spark knock. (Spark knock is a metallic rapping noise.) If severe, this can lead to engine damage. If you detect a persistent heavy spark knock even when using gasoline of the stated oc-**

**tane rating, or if you hear steady spark knock while holding a steady speed on level roads, have your dealer correct the condition. Failure to correct the condition is misuse of the vehicle, for which INFINITI is not responsible.**

Incorrect ignition timing will result in knocking, after-run or overheating. This in turn may cause excessive fuel consumption or damage to the engine. If any of the above symptoms are encountered, have your vehicle checked at an INFINITI dealer or other competent service facility.

**However, now and then you may notice light spark knock for a short time while accelerating or driving up hills. This is no cause for concern, because you get the greatest fuel benefit when there is light spark knock for a short time under heavy engine load.**

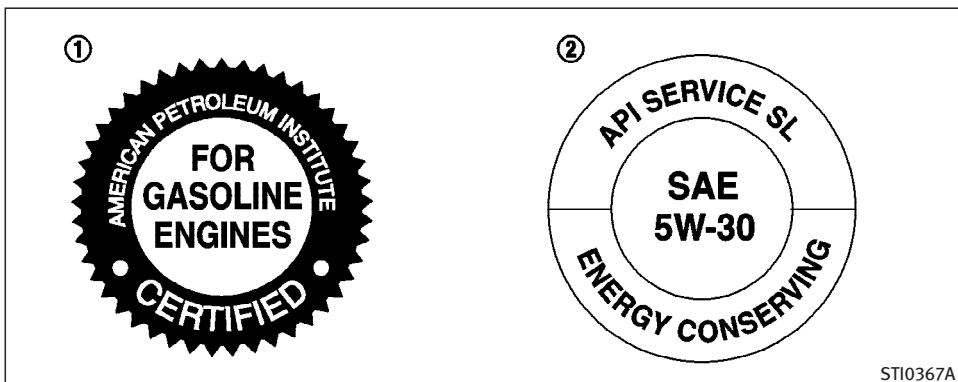

- ① API certification mark
- ② API service symbol

## ENGINE OIL AND OIL FILTER RECOMMENDATION

### Selecting the correct oil

It is essential to choose the correct grade, quality and viscosity engine oil to ensure satisfactory engine life and performance. See “Capacities and recommended fuel/lubricants” earlier in this section. INFINITI recommends the use of an energy conserving oil in order to improve fuel economy.

Select only engine oils that meet the American Petroleum Institute (API) certification or International Lubricant Standardization and Approval Committee (ILSAC) certification and SAE viscosity standard. These oils have the API certification mark on the front of the container. Oils which do not have the specified quality label should not be used as they could cause engine damage.

### Oil additives

INFINITI does not recommend the use of oil additives. The use of an oil additive is not necessary when the proper oil type is

used and maintenance intervals are followed.

Oil which may contain foreign matter or has been previously used should not be used.

### Oil viscosity

The engine oil viscosity or thickness changes with temperature. Because of this, it is important that the engine oil viscosity be selected based on the temperatures at which the vehicle will be operated before the next oil change. The recommended SAE viscosity number chart shows the recommended oil viscosities for the expected ambient temperatures. Choosing an oil viscosity other than that recommended could cause serious engine damage.

### Selecting the correct oil filter

Your new vehicle is equipped with a high-quality genuine NISSAN oil filter. When replacing, use the genuine oil filter or its equivalent for the reason described in change intervals.

### Change intervals

The oil and oil filter change intervals for your engine are based on the use of the

specified quality oils and filters. Oil and filter other than the specified quality, or oil and filter change intervals longer than recommended could reduce engine life. Damage to engines caused by improper maintenance or use of incorrect oil and filter quality and/or viscosity is not covered by the new INFINITI vehicle limited warranties.

Your engine was filled with a high quality engine oil when it was built. You do not have to change the oil before the first recommended change interval. Oil and filter change intervals depend upon how you use your vehicle. Operation under the following conditions may require more frequent oil and filter changes.

- repeated short distance driving at cold outside temperatures
- driving in dusty conditions
- extensive idling
- towing a trailer
- stop and go commuting

Refer to the “INFINITI Service and Maintenance Guide” for the maintenance schedule.

## 9-6 Technical and consumer information

### RECOMMENDED SAE VISCOSITY NUMBER

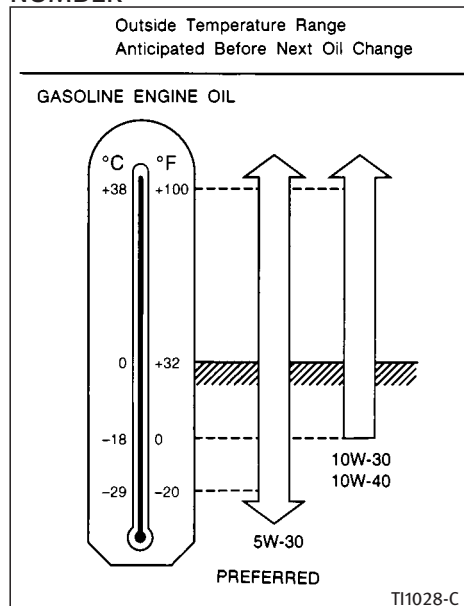

**SAE 5W-30 viscosity oil is preferred for all ambient temperatures. SAE 10W-30, 10W-40 viscosity oil may be used if the ambient temperature is above 0°F (-18°C).**

### AIR CONDITIONING SYSTEM REFRIGERANT AND LUBRICANT RECOMMENDATIONS

The air conditioning system in this INFINITI vehicle must be charged with the refrigerant HFC-134a (R-134a) and the lubricant, Nissan A/C System Oil Type S or the exact equivalents.



#### CAUTION

The use of any other refrigerant or lubricant will cause severe damage to the air conditioning system and will require the replacement of all air conditioner system components.

The refrigerant HFC-134a (R-134a) in your INFINITI vehicle will not harm the earth's ozone layer. Although this refrigerant does not affect the earth's atmosphere, certain governmental regulations require the recovery and recycling of any refrigerant during automotive air conditioning system service. An INFINITI dealer has the trained technicians and equipment needed to recover and recycle your air conditioning system refrigerant.



Contact an INFINITI dealer when servicing your air conditioning system.

## SPECIFICATIONS

### ENGINE

Model		VQ35DE	VK45DE
Type		Gasoline, 4-cycle	Gasoline, 4-cycle
Cylinder arrangement		6-cylinder, V-slanted at 60°	8-cylinder, V-slanted at 90°
Bore × Stroke	in (mm)	3.760 × 3.205 (95.5 × 81.4)	3.661 × 3.256 (93.0 × 82.7)
Displacement	cu in (cm <sup>3</sup> )	213.45 (3,498)	274.2 (4,494)
Firing order		1-2-3-4-5-6	1-8-7-3-6-5-4-2
Idle speed	rpm	See the emission control information label on the underside of the hood.	
Ignition timing (B.T.D.C.)	degree/rpm		
Spark plug	Standard	PLFR5A-11	PLFR5A-11
	Service option	Hot type	PLFR4A-11
		Cold type	PLFR6A-11
Spark plug gap (Normal)	in (mm)	0.043 (1.1)	0.043 (1.1)
Camshaft operation		Timing chain	Timing chain

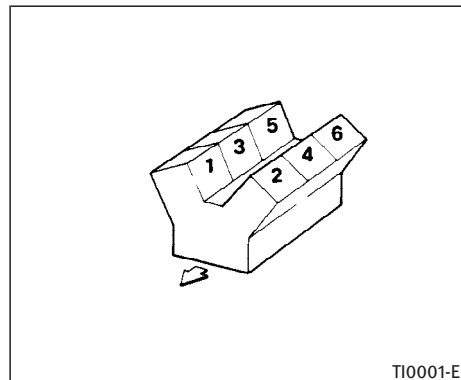

**VQ35DE**

TI0001-E

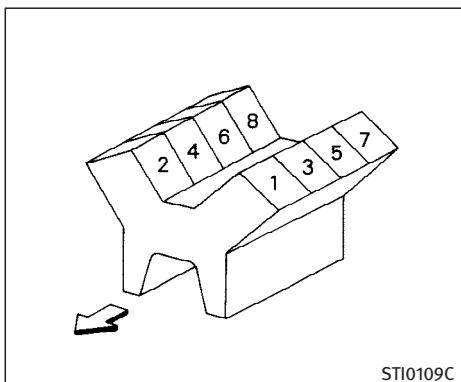

**VQ45DE**

**The spark ignition system of this vehicle meets all requirements of the Canadian Interference-Causing Equipment Regulations.**

## WHEELS AND TIRES

### Road wheel

Type	Size	Offset	in (mm)
Aluminum	18 x 8JJ 20 x 8JJ	1.57 (40)	

### Tire

Type	Size	Pressure (Cold)
Conventional	P265/60R18	220 kPa, 32 psi
	P265/50R20	
Run-flat*	P265/50R20	
Spare (T-type)*	T175/90D18	420 kPa, 60 psi

\*: if so equipped

## DIMENSIONS AND WEIGHTS

Overall length	in (mm)	189.1 (4,803)
Overall width	in (mm)	75.8 (1,925)
Overall height	in (mm)	65.9 (1,672.6)
Front tread	in (mm)	62.7 (1,592)
Rear tread	in (mm)	64.6 (1,642)
Wheelbase	in (mm)	112.2 (2,850)
Gross vehicle weight rating	See the F.M.V.S.S./C.M.V.S.S. certification label on the driver's side lock pillar.	
Gross axle weight rating		

## WHEN TRAVELING OR REGISTERING YOUR VEHICLE IN ANOTHER COUNTRY

**When planning to travel in another country**, you should first find out if the fuel available is suitable for your vehicle's engine.

Using fuel with too low an octane rating may cause engine damage. All gasoline vehicles must be operated with unleaded engine gasoline. Therefore, avoid taking your vehicle to areas where appropriate fuel is not available.

**When transferring the registration of your vehicle to another country, state, province or district**, it may be necessary to modify the vehicle to meet local laws and regulations.

The laws and regulations for motor vehicle emission control and safety standards vary according to the country, state, province or district; therefore, vehicle specifications may differ.

**When any vehicle is to be taken into another country, state, province or district and registered, its modifications, transportation, and registration are the responsibility of the user. INFINITI is not responsible for any inconvenience that may result.**

## VEHICLE IDENTIFICATION

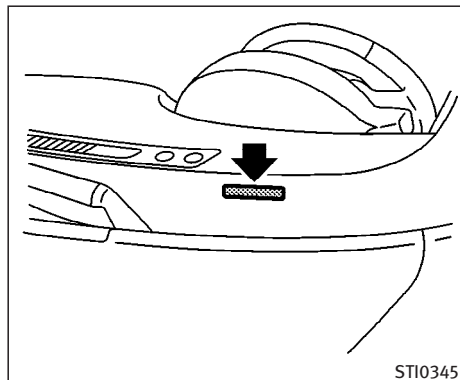

### VEHICLE IDENTIFICATION NUMBER (VIN) PLATE

The vehicle identification number plate is attached as shown. This number is the identification for your vehicle and is used in the vehicle registration.

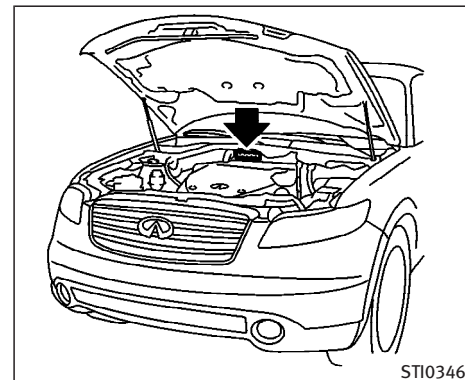

### VEHICLE IDENTIFICATION NUMBER (Chassis number)

The number is stamped as shown.

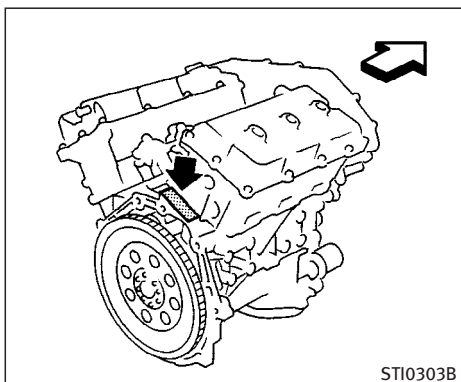

STI0303B

**VQ35DE**

### ENGINE SERIAL NUMBER

The number is stamped on the engine as shown.

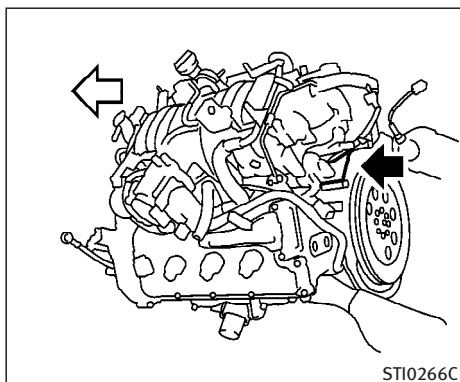

STI0266C

**VK45DE**

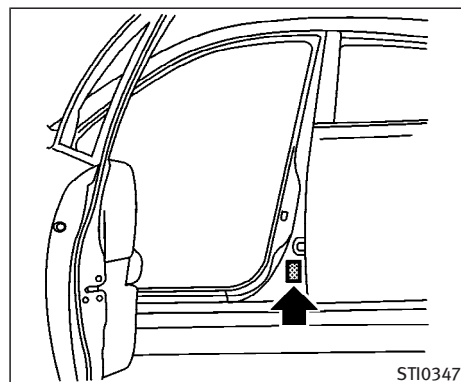

STI0347

### F.M.V.S.S./C.M.V.S.S. CERTIFICATION LABEL

The Federal Motor Vehicle Safety Standards (F.M.V.S.S.) or Canadian Motor Vehicle Safety Standards (C.M.V.S.S.) certification label is affixed as shown. This label contains valuable vehicle information, such as: Gross Vehicle Weight Ratings (GVWR), Gross Axle Weight Rating (GAWR), month and year of manufacture, Vehicle Identification Number, (VIN), etc. Review it carefully.

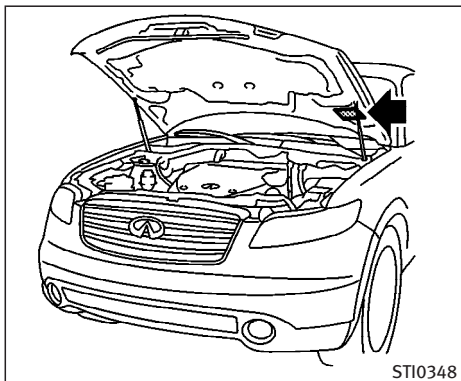

### EMISSION CONTROL INFORMATION LABEL

The emission control information label is attached as shown.

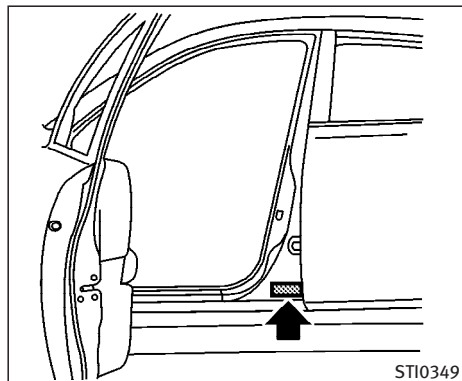

### TIRE AND LOADING INFORMATION LABEL

The cold tire pressure is shown on the Tire and Loading Information label affixed as shown.

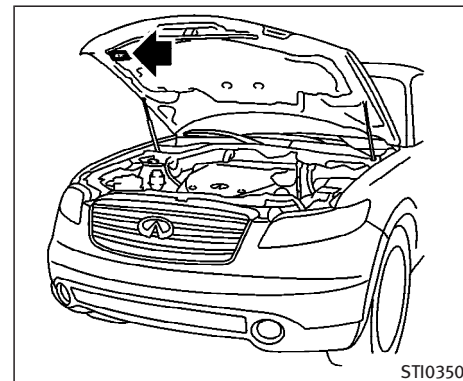

### AIR CONDITIONER SPECIFICATION LABEL

The air conditioner specification label is affixed inside of the hood as shown.

## INSTALLING FRONT LICENSE PLATE

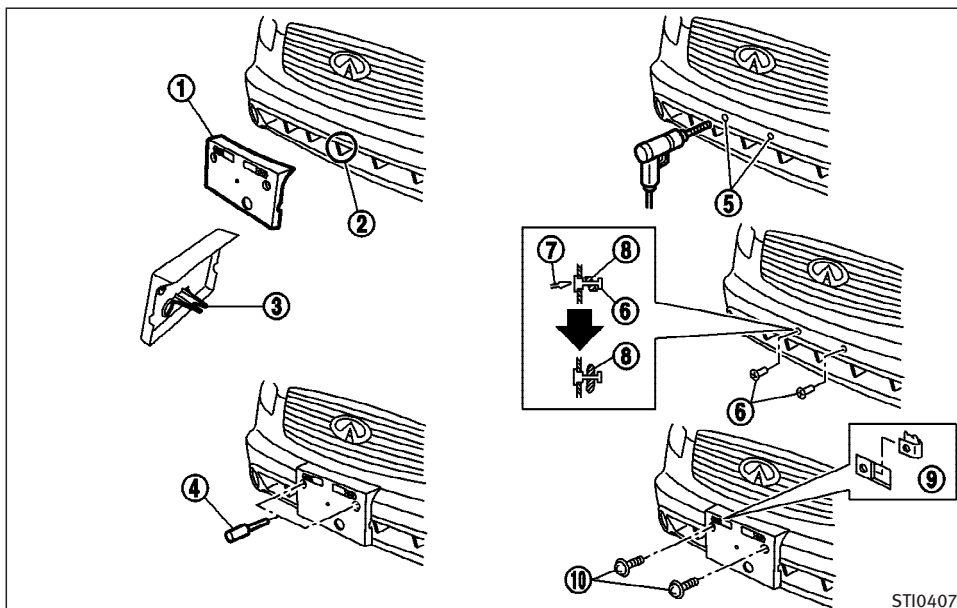

Use the following steps to mount the license plate:

Before mounting the license plate, confirm that the following parts are enclosed in the vinyl bag.

- License plate bracket
- J-nut x 2
- Screw x 2
- Screw grommet x 2

1. Temporarily place the license plate bracket (1) while aligning part (2) of the front bumper with part (3) of the rear surface of the license plate bracket.
2. To determine where to drill the hole, mark along both sides of the mounting hole by using a felt-tip pen (4).
3. Remove the license plate bracket and connect the arcs to form ovals. Mark the point in the center of each oval. These are the pilot drilling locations.
4. Carefully drill two pilot holes using a 0.39 inch (10 mm) drill bit at the marked locations (5). **(Be sure that the drill only goes through the fascia, or damage to the nut may occur.)**
5. Insert grommets (6) into the hole on the fascia.
6. Insert a flat-blade screwdriver (7) into the grommet hole to turn the threaded part of the grommet 90° (8).
7. Insert a J-nut (9) into the license plate bracket before placing the license plate bracket on the fascia.



## VEHICLE LOADING INFORMATION

8. Install the license plate bracket with screws ⑩.
9. Install the license plate with bolts that are no longer than 0.55 inch (14 mm).



### WARNING

- **It is extremely dangerous to ride in a cargo area inside a vehicle. In a collision, people riding in these areas are more likely to be seriously injured or killed.**
- **Do not allow people to ride in any area of your vehicle that is not equipped with seats and seat belts.**
- **Be sure everyone in your vehicle is in a seat and using a seat belt properly.**

## TERMS

It is important to familiarize yourself with the following terms before loading your vehicle:

- **Curb Weight** (actual weight of your vehicle) - vehicle weight including: standard and optional equipment, fluids, emergency tools, and spare tire assembly. This weight **does not** include passengers and cargo.

- **GVW (Gross Vehicle Weight)** - curb weight plus the combined weight of passengers and cargo.
- **GVWR (Gross Vehicle Weight Rating)** - maximum total combined weight of the unloaded vehicle, passengers, luggage, hitch, trailer tongue load and any other optional equipment. This information is located on the F.M.V.S.S./C.M.V.S.S. label.
- **GAWR (Gross Axle Weight Rating)** - maximum weight (load) limit specified for the front or rear axle. This information is located on the F.M.V.S.S. label.
- **GCWR (Gross Combined Weight Rating)** - maximum total weight rating of the vehicle, passengers, cargo, and trailer.
- **Vehicle Capacity Weight, Load limit, Total load capacity** - maximum total weight limit specified of the load (passengers and cargo) for the vehicle. This is the maximum combined weight of occupants and cargo that can be loaded into the vehicle. If the vehicle is used to tow a trailer, the

trailer tongue weight must be included as part of the cargo load. This information is located on the Tire and Loading Information label (if so equipped).

- Cargo capacity - permissible weight of cargo, the subtracted weight of occupants from the load limit.

## VEHICLE LOAD CAPACITY

Do not exceed the load limit of your vehicle shown as “The combined weight of occupants and cargo” on the Tire and Loading Information label. Do not exceed the number of occupants shown as “Seating Capacity” on the Tire and Loading Information label.

To get “the combined weight of occupants and cargo”, add the weight of all occupants, then add the total luggage weight to the value. Examples are shown in the following illustration.

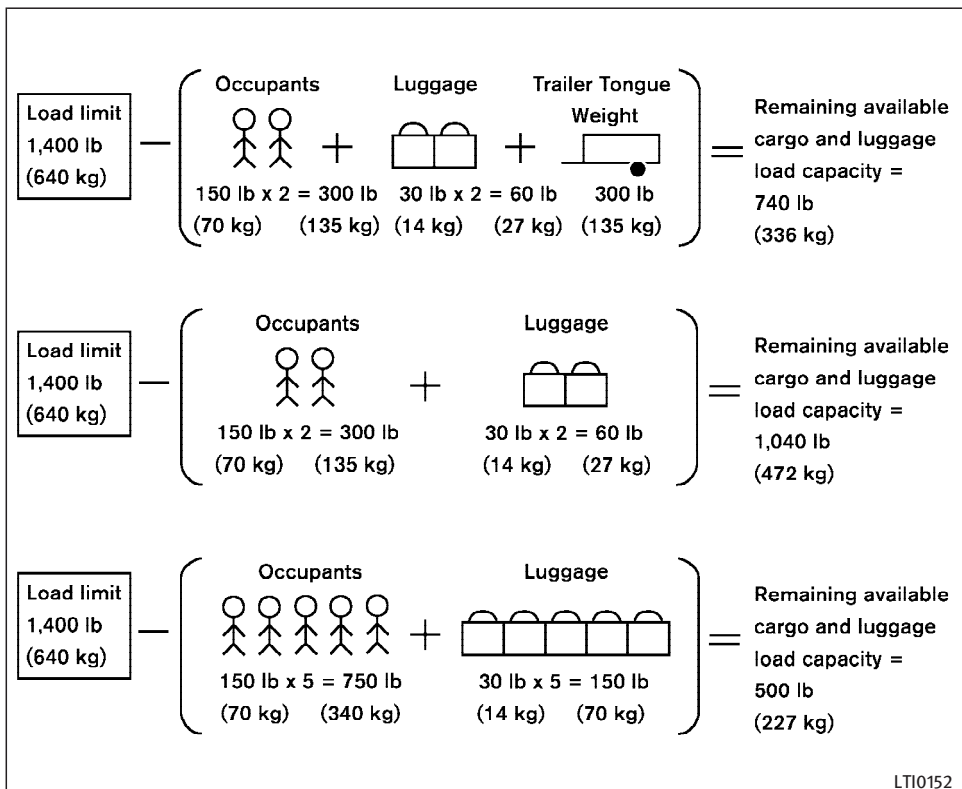

### Steps for determining correct load limit

1. Locate the statement “The combined weight of occupants and cargo should never exceed XXX kg or XXX lbs” on your vehicle’s placard.
2. Determine the combined weight of the driver and passengers that will be riding in your vehicle.
3. Subtract the combined weight of the driver and passengers from XXX kg or XXX lbs.
4. The resulting figure equals the available amount of cargo and luggage load capacity. For example, if the XXX amount equals 1400 lbs. and there will be five 150 lb. passengers in your vehicle, the amount of available cargo and luggage load capacity is 650 lbs. ( $1400 - 750 (5 \times 150) = 650$  lbs) or ( $650 - 340 (5 \times 70) = 300$  kg.)
5. Determine the combined weight of luggage and cargo being loaded on the vehicle. That weight may not safely exceed the available cargo and luggage load capacity calculated in Step 4.

6. If your vehicle will be towing a trailer, load from your trailer will be transferred to your vehicle. Consult this manual to determine how this reduces the available cargo and luggage load capacity of your vehicle.

Before driving a loaded vehicle, confirm that you do not exceed the Gross Vehicle Weight Rating (GVWR) or the Gross Axle Weight Rating (GAWR) for your vehicle. See “Measurement of Weights” later in this section.

Also check tires for proper inflation pressures. See the Tire and Loading Information label.

#### LOADING TIPS

- The GVW must not exceed GVWR or GAWR as specified on the F.M.V.S.S./C.M.V.S.S. certification label.
- Do not load the front and rear axle to the GAWR. Doing so will exceed the GVWR.



#### WARNING

- **Properly secure all cargo with ropes or straps to help prevent it from sliding or shifting. Do not place cargo higher than the seatbacks. In a sudden stop or collision, unsecured cargo could cause personal injury.**
- **Do not load your vehicle any heavier than the GVWR or the maximum front and rear GAWRs. If you do, parts of your vehicle can break, tire damage could occur, or it can change the way your vehicle handles. This could result in loss of control and cause personal injury.**
- **Overloading not only can shorten the life of your vehicle and the tire, but can also cause unsafe vehicle handling and longer braking distances. This may cause a premature tire failure which could result in a serious accident and personal injury. Failures caused by over-**

**loading are not covered by the vehicle's warranty.**

#### MEASUREMENT OF WEIGHTS

Secure loose items to prevent weight shifts that could affect the balance of your vehicle. When the vehicle is loaded, drive to a scale and weigh the front and the rear wheels separately to determine axle loads. Individual axle loads should not exceed either of the gross axle weight rating (GAWR). The total of the axle loads should not exceed the gross vehicle weight rating (GVWR). These ratings are given on the vehicle certification label. If weight ratings are exceeded, move or remove items to bring all weights below the ratings.

## TOWING A TRAILER

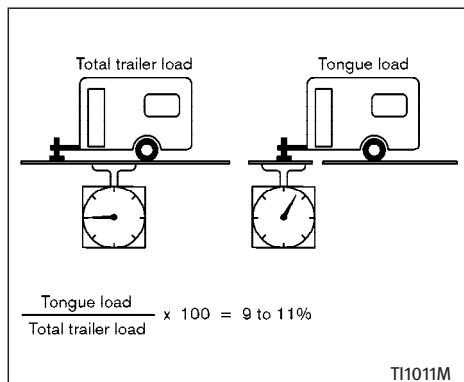

### WARNING

Overloading or improper loading of a trailer and its cargo can adversely affect vehicle handling, braking and performance and may lead to accidents.



### CAUTION

- Do not tow a trailer or haul a heavy load for the first 500 miles (800 km).

Your engine, axle or other parts could be damaged.

- For the first 500 miles (800 km) that you tow a trailer, do not drive over 50 MPH (80 km/h) and do not make starts at full throttle. This helps the engine and other parts of your vehicle wear in at the heavier loads.

Your new vehicle was designed to be used primarily to carry passengers and cargo. Remember that towing a trailer will place additional loads on your vehicle's engine, drive train, steering, braking and other systems.

An INFINITI Towing Guide (U.S. only) is available on the website at [www.infiniti.com](http://www.infiniti.com). This guide includes information on trailer towing capability and the special equipment required for proper towing.

### MAXIMUM LOAD LIMITS

#### Maximum trailer loads

Never allow the total trailer load to exceed the value specified in the following Towing Load/Specification Chart. The total trailer

load equals trailer weight plus its cargo weight.

- When towing a trailer load of 1,000 lbs (454 kg) or more, trailers with a brake system MUST be used.

The maximum GCWR (Gross Combined Weight Rating) should not exceed the value specified in the following Towing Load/Specification Chart.

The GCWR equals the combined weight of the towing vehicle (including passengers and cargo) plus the total trailer load.

Towing loads greater than these or using improper towing equipment could adversely affect vehicle handling, braking and performance.

The ability of your vehicle to tow a trailer is not only related to the maximum trailer loads, but also the places you plan to tow. Tow weights appropriate for level highway driving may have to be reduced on very steep grades or in low traction situations (for example, on slippery boat ramps).



## CAUTION

Vehicle damage resulting from improper towing procedures are not covered by INFINITI warranties.

### Tongue load

Keep the tongue load between 9 to 11% of the total trailer load within the maximum tongue load limits shown in the following Towing Load/Specifications Chart. If the tongue load becomes excessive, rearrange cargo to allow for proper tongue load.

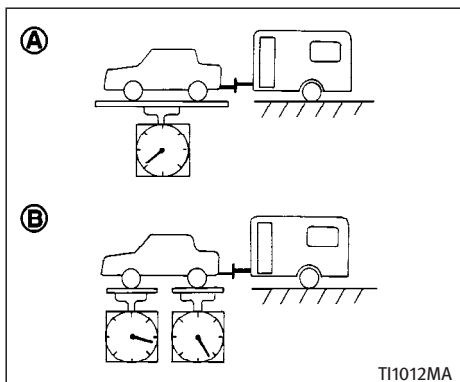

### Maximum gross vehicle weight/ maximum gross axle weight

The gross vehicle weight **A** of the towing vehicle must not exceed GVWR shown on the F.M.V.S.S./C.M.V.S.S. certification label. The gross vehicle weight equals the combined weight of the unloaded vehicle, passengers, luggage, hitch, trailer tongue load and any other optional equipment. In addition, front or rear gross axle weight **B** must not exceed GAWR shown on the F.M.V.S.S./C.M.V.S.S. certification label.

## TOWING LOAD/SPECIFICATION CHART

TOWING LOAD/SPECIFICATION CHART		
	Unit: lb (kg)	
	VQ35DE	VK45DE
MAXIMUM TRAILER WEIGHT*1	3,500 (1,588)	
MAXIMUM TONGUE LOAD	350 (159)	
GROSS COMBINED WEIGHT RATING	8,000 (3,629)	8,100 (3,674)
RECOMMENDED EQUIPMENT*2	Sway Control Device (SCD)	

\*1: All towing above 1,000 lb (454 kg) requires the use of trailer brakes. INFINITI recommends the use of a tandem axle trailer whenever towing above 3,000 lb (1,361 kg).

\*2: A sway control device is recommended for all towing above 2,000 lb (907 kg). Sway control devices are not offered by INFINITI. See a professional trailer/hitch outlet for a properly designed sway control device for your trailer.

## TOWING SAFETY

### Trailer hitch

Choose a proper hitch for your vehicle and trailer. Make sure the trailer hitch is securely attached to the vehicle, to help avoid personal injury or property damage due to sway caused by crosswinds, rough road surfaces or passing trucks.

### Hitch ball

Choose a hitch ball of the proper size and weight rating for your trailer:

- The required hitch ball size is stamped on most trailer couplers. Most hitch balls also have the size printed on top of the ball.
- Choose the proper class hitch ball based on the trailer weight.
- The diameter of the threaded shank of the hitch ball must be matched to the ball mount hole diameter. The hitch ball shank should be no more than 1/16" smaller than the hole in the ball mount.
- The threaded shank of the hitch ball must be long enough to be properly secured to the ball mount. There should

be at least 2 threads showing beyond the lock washer and nut.

## Class I hitch

Class I trailer hitch equipment (receiver, ball mount and hitch ball) can be used to tow trailers of a maximum weight of 2,000 lb (909 kg).

## Class II hitch

Class II trailer hitch equipment (receiver, ball mount and hitch ball) can be used to tow trailers of a maximum weight of 3,500 lb (1,510 kg).



### CAUTION

- Do not use axle-mounted hitches.
- The hitch should not be attached to or affect the operation of the impact-absorbing bumper.
- Do not modify the vehicle exhaust system, brake system, etc. to install a trailer hitch.
- To reduce the possibility of additional-damage if your vehicle is struck from the

rear, where practical, remove the hitch and/or receiver when not in use. After the hitch is removed, seal the bolt holes to prevent exhaust fumes, water or dust from entering the passenger compartment.

- Regularly check that all trailer hitch mounting bolts are securely mounted.

## Tire pressures

- When towing a trailer, inflate the vehicle tires to the recommended cold tire pressure indicated on the Tire and Loading Information label.
- Trailer tire condition, size, load rating and proper inflation pressure should be in accordance with the trailer and tire manufacturers' specifications.

## Safety chains

Always use a suitable chain between your vehicle and the trailer. The safety chains should be crossed and should be attached to the hitch, not to the vehicle bumper or axle. Be sure to leave enough slack in the chains to permit turning corners.

## Trailer lights



### CAUTION

When splicing into the vehicle electrical system, a commercially available power-type module/converter must be used to provide power for all trailer lighting. This unit uses the vehicle battery as a direct power source for all trailer lights while using the vehicle tail light, stoplight and turn signal circuits as a signal source. The module/converter must draw no more than 15 milliamps from the stop and tail lamp circuits. Using a module/converter that exceeds these power requirements may damage the vehicle's electrical system. See a reputable trailer dealer to obtain the proper equipment and to have it installed.

Trailer lights should comply with federal and/or local regulations. For assistance in hooking up trailer lights, contact an INFINITI dealer or reputable trailer dealer.



## Trailer brakes

If your trailer is equipped with a braking system, make sure it conforms to federal and/or local regulations and that it is properly installed.



### WARNING

**Never connect a trailer brake system directly to the vehicle brake system.**

## Pre-towing tips

- Be certain your vehicle maintains a level position when a loaded or unloaded trailer is hitched. Do not drive the vehicle if it has an abnormal nose-up or nose-down condition; check for improper tongue load, overload, worn suspension or other possible causes of either condition.
- Always secure items in the trailer to prevent load shifts while driving.
- Load the trailer so approximately 60% of the trailer load is in the front half and 40% is in the back half.
- Check your hitch, trailer tire pressure, vehicle tire pressure, trailer light opera-

tion, and trailer wheel lug nuts every time you attach a trailer to the vehicle.

- Be certain your rear view mirrors conform to all federal, state or local regulations. If not, install any mirrors required for towing before driving the vehicle.

## Trailer towing tips

In order to gain skill and an understanding of the vehicle's behavior, you should practice turning, stopping and backing up in an area which is free from traffic. Steering stability, and braking performance will be somewhat different than under normal driving conditions.

- Always secure items in the trailer to prevent load shift while driving.
- Avoid abrupt starts, acceleration or stops.
- Avoid sharp turns or lane changes.
- Always drive your vehicle at a moderate speed. Some states or provinces have specific speed limits for vehicles that are towing trailers. Obey the local speed limits.
- When backing up, hold the bottom of the steering wheel with one hand. Move

your hand in the direction in which you want the trailer to go. Make small corrections and back up slowly. If possible, have someone guide you when you are backing up.

- Always block the wheels on both vehicle and trailer when parking. Parking on a slope is not recommended; however, if you must do so, and if your vehicle is equipped with automatic transmission, first block the wheels and apply the parking brake, and then move the transmission selector lever into the P (Park) position. If you move the selector lever to the P (Park) position before blocking the wheels and applying the parking brake, transmission damage could occur.
- When going down a hill, shift into a lower gear and use the engine braking effect. When going up a long grade, downshift the transmission to a lower gear and reduce speed to reduce chances of engine overloading and/or overheating.
- If the engine coolant rises to an extremely high temperature when the air conditioning system is on, turn off the

air conditioner. Coolant heat can be additionally vented by opening the windows, switching the fan control to high and setting the temperature control to the HOT position.

- Trailer towing requires more fuel than normal circumstances.
- Avoid towing a trailer for the first 500 miles (800 km).
- Have your vehicle serviced more often than at intervals specified in the recommended maintenance schedule in the INFINITI Service and Manual Guide.
- When making a turn, your trailer wheels will be closer to the inside of the turn than your vehicle wheels. To compensate for this, make a larger than normal turning radius during the turn.
- Crosswinds and rough roads will adversely affect vehicle/trailer handling, possibly causing vehicle sway. When being passed by larger vehicles, be prepared for possible changes in crosswinds that could affect vehicle handling. If swaying does occur, firmly grip the steering wheel, steer straight ahead, and immediately (but gradually) reduce vehicle speed. This combination

will help stabilize the vehicle. Never increase speed.

- Be careful when passing other vehicles. Passing while towing a trailer requires considerably more distance than normal passing. Remember the length of the trailer must also pass the other vehicle before you can safely change lanes.
- To maintain engine braking efficiency and electrical charging performance, do not use overdrive.
- Avoid holding the brake pedal down too long or too frequently. This could cause the brakes to overheat, resulting in reduced braking efficiency.
- Increase your following distance to allow for greater stopping distances while towing a trailer. Anticipate stops and brake gradually.
- Do not use cruise control while towing a trailer.
- Check your hitch, trailer wiring harness connections, and trailer wheel lug nuts after 50 miles (80 km) of travel and at every break.

- When stopped in traffic for long periods of time in hot weather, put the vehicle in the P (Park) position.

**When towing a trailer, change fluid in the transmission more frequently.**

**For additional information, see the “8. Maintenance and do-it-yourself” section earlier in this manual.**

## FLAT TOWING

Towing your vehicle with all four wheels on the ground is sometimes called flat towing. This method is sometimes used when towing a vehicle behind a recreational vehicle, such as a motor home.



### CAUTION

- Failure to follow these guidelines can result in severe transmission damage.
- Whenever flat towing your vehicle, always tow forward, never backward.

- **DO NOT tow any automatic transmission vehicle with all four wheels on the ground (flat towing). Doing so WILL DAMAGE internal transmission parts due to lack of transmission lubrication.**
- **For emergency towing procedures, see “Towing recommended by INFINITI” in the “6. In case of emergency” section of this manual.**

To tow a vehicle equipped with an automatic transmission, an appropriate vehicle dolly **MUST** be placed under the towed vehicle’s drive wheels. **Always** follow the dolly manufacturer’s recommendations when using their product.

## UNIFORM TIRE QUALITY GRADING

DOT (Department Of Transportation) Quality Grades: All passenger car tires must conform to federal safety requirements in addition to these grades.

Quality grades can be found where applicable on the tire sidewall between tread shoulder and maximum section width. For example:

**Treadwear 200 Traction AA Temperature A Treadwear**

The treadwear grade is a comparative rating based on the wear rate of the tire when tested under controlled conditions on a specified government test course. For example, a tire graded 150 would wear one and one-half (1 1/2) times as well on the government course as a tire graded 100. The relative performance of tires depends upon the actual conditions of their use, however, and may depart significantly from the norm due to variations in driving habits, service practices and differences in road characteristics and climate.

**Traction AA, A, B and C**

The traction grades, from highest to lowest, are AA, A, B, and C. Those grades represent the tire’s ability to stop on wet

pavement as measured under controlled conditions on specified government test surfaces of asphalt and concrete. A tire marked C may have poor traction performance.



### WARNING

**The traction grade assigned to this tire is based on straight-ahead braking traction tests, and does not include acceleration, cornering, hydroplaning, or peak traction characteristics.**

**Temperature A, B and C**

The temperature grades are A (the highest), B, and C, representing the tire’s resistance to the generation of heat and its ability to dissipate heat when tested under controlled conditions on a specified indoor laboratory test wheel. Sustained high temperature can cause the material of the tire to degenerate and reduce tire life, and excessive temperature can lead to sudden tire failure. The grade C corresponds to a level of performance which all passenger car tires must meet under the Federal Motor Safety Standard No. 109. Grades B and A represent higher levels of perfor-

**Technical and consumer information 9-25**

mance on the laboratory test wheel than the minimum required by law.



## WARNING

The temperature grade for this tire is established for a tire that is properly inflated and not overloaded. Excessive speed, underinflation, or excessive loading, either separately or in combination, can cause heat build-up and possible tire failure.

## EMISSION CONTROL SYSTEM WARRANTY

Your INFINITI is covered by the following emission warranties.

### For US:

- Emission Defects Warranty
- Emissions Performance Warranty (See Warranty Information Booklet for details.)

### For Canada:

#### Emission Control System Warranty

Details of these warranties may be found with other vehicle warranties in your Warranty Information Booklet (Warranty and Roadside Assistance Information (Canada only)) that comes with your INFINITI. If you did not receive a Warranty Information Booklet (Warranty and Roadside Assistance Information (Canada only)), or it has become lost, you may obtain a replacement by writing to:

- INFINITI Division  
Nissan North America, Inc.  
Consumer Affairs Department  
P.O. Box 47038, Gardena, CA 90247-6838
- Nissan Canada Inc.  
5290 Orbitor Drive  
Mississauga, Ontario, L4W 4Z5

## REPORTING SAFETY DEFECTS (US only)

If you believe that your vehicle has a defect which could cause a crash or could cause injury or death, you should immediately inform the National Highway Traffic Safety Administration (NHTSA) in addition to notifying INFINITI.

If NHTSA receives similar complaints, it may open an investigation, and if it finds that a safety defect exists in a group of vehicles, it may order a recall and remedy campaign. However, NHTSA cannot become involved in individual problems between you, your dealer, or INFINITI.

To contact NHTSA, you may call the Vehicle Safety Hotline toll-free at 1-888-327-4236 (TTY: 1-800-424-9153); go to <http://www.safercar.gov>; or write to: Administrator, NHTSA, 400 Seventh Street, SW., Washington, DC 20590. You can also obtain other information about motor vehicle safety from <http://www.safercar.gov>.

You may notify INFINITI by contacting our Consumer Affairs Department, toll-free, at 1-800-662-6200.

### **READINESS FOR INSPECTION/ MAINTENANCE (I/M) TEST (US only)**

A vehicle equipped with All-Wheel Drive (AWD) should never be tested using a two wheel dynamometer (such as the dynamometers used by some states for emissions testing), or similar equipment. Make sure you inform test facility personnel that your vehicle is equipped with AWD before it is placed on a dynamometer. Using the wrong test equipment may result in transmission damage or unexpected vehicle movement which could result in serious vehicle damage or personal injury.

Due to legal requirements in some states/areas, your vehicle may be required to be in what is called the “ready condition” for an Inspection/Maintenance (I/M) test of the emission control system.

The vehicle is set to the “ready condition” when it is driven through certain driving patterns. Usually, the “ready condition” can be obtained by ordinary usage of the vehicle.

If a powertrain system component is repaired or the battery is disconnected, the vehicle may be reset to a “not ready condition”. Before taking the I/M test, check the vehicle’s inspection/maintenance test readiness condition. Turn the ignition switch to the ON position without starting

the engine. If the Malfunction Indicator Lamp (MIL) comes on steady for 20 seconds and then blinks for 10 seconds, the I/M test condition is “not ready”. If the MIL does not blink after 20 seconds, the I/M test condition is “ready”.

If the MIL indicates the vehicle is in a “not ready” condition, drive the vehicle through the following pattern to set the vehicle to the “ready condition”. If you cannot or do not want to perform the driving pattern, an INFINITI dealer can conduct it for you.



### **WARNING**

**Always drive the vehicle in a safe and prudent manner according to traffic conditions, and obey all traffic laws.**

1. Start the engine. Allow the engine to idle until the engine coolant temperature gauge needle points between the C and H (normal operating temperature).
2. Accelerate the vehicle to 55 MPH (88 km/h), then quickly release the accelerator pedal completely and keep it released for at least 10 seconds.

## EVENT DATA RECORDERS

3. Quickly depress the accelerator pedal for a moment, then drive the vehicle at a speed of 53 to 60 MPH (86 to 96 km/h) for at least 9 minutes.
4. Stop the vehicle. Leave the engine running.
5. Accelerate the vehicle to 35 MPH (55 km/h) and maintain the speed for 20 seconds.
6. Repeat steps 4 and 5 at least 10 times.
7. Accelerate the vehicle to 55 MPH (88 km/h) and maintain the speed for at least 3 minutes.
8. Stop the vehicle. Place the transmission gear selector lever in the “P” or “N” position.
9. Turn the engine off.
10. Repeat steps 1 through 8 at least one more time.

If step 1 through 7 is interrupted, repeat the preceding step. Any safe driving mode is acceptable between steps. Do not stop the engine until step 7 is completed.

Your vehicle is equipped with a variety of computers that monitor and control a number of systems to optimize performance and help service technicians with diagnosis and repair. Depending on the equipment on your vehicle, some of the computers monitor emission control systems, braking systems, engine systems, transmission systems, tire pressure systems, and air bag systems. Some data about vehicle operation may be stored in the computers for use during servicing. Other data may be stored if a crash event occurs. For example, air bag readiness, air bag performance, and seat belt use by the driver or passenger may be recorded, depending on vehicle equipment. These types of systems are sometimes called Event Data Recorders.

Special equipment can be used to access the electronic data that may be stored in the vehicle’s computers (sounds are not recorded). INFINITI and INFINITI dealers have equipment to access some of this data; others may also have this equipment. The data may be retrieved during routine vehicle servicing or for special research. It might also be accessed with the consent of the vehicle owner or lessee in response to a request by law enforcement, or as otherwise required or permitted by law.

## OWNER'S MANUAL/SERVICE MANUAL ORDER INFORMATION

A genuine INFINITI Service Manual is the best source of service and repair information for your vehicle. Filled with wiring diagrams, illustrations and step-by-step diagnostic and adjustment procedures, this manual is the same one used by the factory trained technicians working at authorized INFINITI dealerships. Also available are genuine INFINITI Owner's Manuals, and genuine INFINITI Service and Owner's Manuals for older INFINITI models.

### In the USA:

For current pricing and availability of genuine **INFINITI Service Manuals** for the 2000 model year and later, contact:

Tweddle Litho Company  
1-800-450-9491  
www.nissan-techinfo.com

For current pricing and availability of genuine **INFINITI Service Manuals** for the 1999 model year and prior, see an INFINITI dealer, or contact:

Resolve Corporation  
20770 Westwood Road  
Strongsville, OH 44136  
1-800-247-5321

For current pricing and availability of genuine **INFINITI Owner's Manuals** for this

model year and prior, see an INFINITI dealer, or contact:

Resolve Corporation  
20770 Westwood Road  
Strongsville, OH 44136  
1-800-247-5321

### In Canada:

To purchase a copy of a genuine INFINITI Service Manual or Owner's Manual please contact an INFINITI dealer. For the phone number and location of an INFINITI dealer in your area call the INFINITI Satisfaction Center at 1-800-361-4792 and a bilingual INFINITI representative will assist you.

Also available are genuine INFINITI Service and Owner's Manuals for older INFINITI models.

## IN THE EVENT OF A COLLISION

Unfortunately, accidents do occur. In this unlikely event, there is some important information you should know. Many insurance companies routinely authorize the use of non-genuine collision parts in order to cut costs, among other reasons.

## Insist on the use of Genuine INFINITI Collision Parts!

If you want your vehicle to be restored using parts made to INFINITI's original exacting specifications — if you want to help it to last and hold its resale value, the solution is simple. **Tell your insurance agent and your repair shop to only use Genuine INFINITI Collision Parts.** INFINITI does not warrant non-INFINITI parts, nor does INFINITI's warranty apply to damage caused by a non-genuine part.

Using Genuine INFINITI Parts can help protect your personal safety, preserve your warranty protection and maintain the resale value of your vehicle. And if your vehicle was leased, using Genuine INFINITI Parts may prevent or limit unnecessary excess wear and tear expenses at the end of your lease.

INFINITI designs its hoods with crumple zones to minimize the risk that the hood will penetrate the windshield of your vehicle in an accident. Non-genuine (imitation) parts may not provide such built-in safety features. Also, non-genuine parts often show premature wear, rust and corrosion.

## Why should you take a chance?

In over 40 states and certain territories/provinces, the law says you must be advised if non-genuine parts are used to repair your vehicle. And some states and provinces have enacted laws that restrict insurance companies from authorizing the use of non-genuine collision parts during the new vehicle warranty. These laws help protect you, so you can take action to protect yourself.

### It's your right!

If you should need further information, visit us at:

**[www.infiniti.com](http://www.infiniti.com)** (for U.S. customers) or  
**[www.infiniti.ca](http://www.infiniti.ca)** (for Canadian customers)



# 10 Index

## A

ABS (Anti-lock brake system).....	5-52
Aiming control, Headlights .....	2-26
Air bag system, Front passenger air bag and status light .....	1-45
Air bag warning labels.....	1-51
Air bag warning light .....	1-52, 2-15
Air cleaner housing filter .....	8-21
Air conditioner	
Air conditioner operation.....	4-21
Air conditioner service .....	4-21, 4-24
Air conditioner specification label.....	9-13
Air conditioning system refrigerant and lubricant recommendations.....	4-24, 9-6
Heater and air conditioner (automatic) .....	4-21
In-cabin microfilter .....	4-24
Alarm, How to stop alarm (See vehicle security system).....	2-19
Alcohol, drugs and driving.....	5-7
All-wheel drive (AWD).....	5-46
All-wheel drive (AWD) warning light .....	2-10
Anchor point locations	
Top tether strap .....	1-28
Antenna.....	4-64
Anti-lock Brake System (ABS) .....	5-52
Anti-lock brake warning light.....	2-10
Appearance care	
Exterior appearance care .....	7-2

Interior appearance care .....	7-4
Armrest .....	1-7
Audible reminders .....	2-17
Audio operation precautions .....	4-27
Audio system.....	4-25
Steering wheel audio controls .....	4-40
Autochanger	
Compact Disc (CD).....	4-37
Autolight system.....	2-25
Automatic	
Anti-glare inside mirror.....	3-30
Automatic sunroof.....	2-43
Automatic transmission fluid (ATF) .....	8-15
Drive positioner .....	3-32
Driving with automatic transmission .....	5-14
Seat positioner .....	3-32
Avoiding collision and rollover.....	5-7

## B

Back door (See lift gate) .....	3-24
Battery .....	8-17
Battery saver system .....	2-26
Before starting the engine .....	5-13
Belts (See drive belts) .....	8-19
Bluetooth <sup>®</sup> Hands-Free Phone System .....	4-41
Booster seats .....	1-32
Brake	
Anti-lock brake system (ABS) .....	5-52

Brake booster .....	8-24
Brake fluid .....	8-16
Brake pedal check.....	8-23
Brake system .....	5-49
Parking brake check.....	8-23
Parking brake operation .....	5-18
Warning light .....	2-11
Break-in schedule .....	5-45
Brightness control, Instrument panel .....	2-27
Bulb check/instrument panel .....	2-9
Bulb replacement.....	8-30

## C

Cabin air filter.....	4-24
Capacities and recommended fuel/lubricants .....	9-2
Car phone or CB radio .....	4-65
Card holder.....	2-39
Cargo (See vehicle loading information).....	2-39
Cargo net.....	2-39
Catalytic converter	
Three way catalyst.....	5-3
CD care and cleaning.....	4-39
Child restraints .....	1-19
Booster seats.....	1-32
Installation on front passenger seat .....	1-29
Installation on rear seat outboard or center positions .....	1-21
LATCH system .....	1-26

Precautions on child restraints.....	1-19
Top tether strap .....	1-27
Top tether strap anchor point locations .....	1-28
Child safety .....	1-11
Child safety rear door lock.....	3-5
Chimes	
Audible reminders.....	2-17
Seat belt warning light and chime .....	2-14
Circuit breaker, Fusible link.....	8-26
Cleaning exterior and interior .....	7-2, 7-4
Clock.....	2-32
Cold weather driving .....	5-56
Command (See Bluetooth <sup>®</sup> Hands-Free Phone System).....	4-47
Compact Disc (CD) changer (See audio system) .....	4-37
Compass display .....	2-6
Console box.....	2-38
Control panel buttons (models with navigation system) .....	4-12
Control panel buttons (models without navigation system).....	4-4
Controls	
Control panel buttons (display with navigation system).....	4-12
Control panel buttons (display without navigation system).....	4-4
Heater and air conditioner controls (automatic) .....	4-21
Steering wheel audio controls .....	4-40
Coolant	
Capacities and recommended fuel/lubricants .....	9-2
Changing engine coolant.....	8-10
Checking engine coolant level .....	8-9

Corrosion protection .....	7-5
Cover, Tonneau cover .....	2-40
Cruise control .....	5-22
Cruise control, Fixed speed cruise control (on ICC system) .....	5-41
Cruise control, Intelligent cruise control system .....	5-24
Cup holders.....	2-35

## D

Daytime running light system .....	2-27
Defroster switch, Rear window and outside mirror defroster switch.....	2-23
Dimensions and weights .....	9-10
Display controls (See control panel buttons), With navigation system .....	4-12
Display controls (See control panel buttons), Without navigation system .....	4-4
Door open warning light.....	2-11
Drive belts .....	8-19
Drive positioner .....	3-32
Driving	
Cold weather driving .....	5-56
Driving with automatic transmission .....	5-14
On-pavement and off-load driving.....	5-3
Precautions when starting and driving .....	5-2
Safety precautions .....	5-8
DVD player, INFINITI mobile entertainment system .....	4-55

## E

Economy	
Fuel .....	5-45
Emission control information label .....	9-13
Emission control system warranty .....	9-26
Engine	
Before starting the engine .....	5-13
Break-in schedule .....	5-45
Capacities and recommended fuel/lubricants .....	9-2
Changing engine coolant.....	8-10
Changing engine oil and filter .....	8-13
Checking engine coolant level .....	8-9
Checking engine oil level.....	8-11
Coolant temperature gauge .....	2-5
Engine block heater.....	5-57
Engine compartment check locations .....	8-7
Engine cooling system.....	8-9
Engine oil.....	8-11
Engine oil and oil filter recommendation .....	9-5
Engine oil viscosity.....	9-5
Engine serial number.....	9-12
Engine specifications .....	9-8
If your vehicle overheats .....	6-13
Starting the engine.....	5-14
Entry/exit function, Automatic drive positioner .....	3-29, 3-33
Event data recorders .....	9-28
Exhaust gas (Carbon monoxide) .....	5-2

**F**

F.M.V.S.S./C.M.V.S.S. certification label .....	9-12
Filter	
Air cleaner housing filter .....	8-21
Changing engine oil and filter .....	8-13
Flashers (See hazard warning flasher switch) .....	2-28
Flat tire .....	6-2, 8-41
Flat towing .....	9-24
Floor mat cleaning .....	7-4
Fluid	
Automatic transmission fluid (ATF) .....	8-15
Brake fluid .....	8-16
Capacities and recommended fuel/lubricants .....	9-2
Engine coolant .....	8-9
Engine oil .....	8-11
Power steering fluid .....	8-15
Window washer fluid .....	8-16
FM-AM-Satellite radio with compact disc (CD) changer .....	4-34
Fog light switch .....	2-28
Front passenger air bag and status light .....	1-45
Front power seat adjustment .....	1-2
Fuel	
Capacities and recommended fuel/lubricants .....	9-2
Fuel economy .....	5-45
Fuel octane rating .....	9-3
Fuel recommendation .....	9-3
Fuel-filler cap .....	3-26
Fuel-filler door .....	3-26
Gauge .....	2-5

Fuses .....	8-24
Fusible links .....	8-26

**G**

Garage door opener, HomeLink® Universal Transceiver .....	2-47
Gas cap .....	3-26
Gauge .....	2-3
Engine coolant temperature gauge .....	2-5
Fuel gauge .....	2-5
Odometer .....	2-4
Speedometer .....	2-4
Tachometer .....	2-4
General maintenance .....	8-2
Glove box .....	2-36

**H**

Hands-free phone system, Bluetooth® .....	4-41
Hazard warning flasher switch .....	2-28
Head restraints .....	1-6
Headlights	
Aiming control .....	2-26
Bulb replacement .....	8-31
Headlight switch .....	2-24
Xenon headlights .....	2-23
Headphones (See INFINITI mobile entertainment system) .....	4-58
Heated seats .....	2-29
Heater	
Engine block heater .....	5-57
Heater and air conditioner (automatic) .....	4-21

HomeLink® Universal Transceiver .....	2-47
Hood	
Release .....	3-24
Horn .....	2-29

**I**

Ignition knob (Intelligent Key system) .....	3-14
Ignition switch	
(except Intelligent Key system) .....	5-10
(with Intelligent Key system) .....	5-12
Automatic transmission models .....	5-14
Key positions .....	5-11
Immobilizer system .....	2-20
In-cabin microfilter .....	4-24
Indicator lights .....	2-15
INFINITI advanced air bag system .....	1-43
INFINITI mobile entertainment system (MES) ...	4-55
INFINITI Vehicle Immobilizer System .....	2-20
INFINITI Vehicle Immobilizer System	
Engine start .....	5-11, 5-13
Inside	
Automatic anti-glare mirror .....	3-30
Inspection/maintenance (I/M) test .....	9-27
Instrument brightness control .....	2-27
Instrument panel .....	2-2
Intelligent cruise control (ICC) system .....	5-24
Intelligent cruise control (ICC) system, Preview function .....	5-45
Intelligent Key system .....	3-9
Engine starting .....	3-14
Key operating range .....	3-16
Key operation .....	3-12
Mechanical key and valet key .....	3-23

Operating the engine.....	3-14
Remote keyless operation .....	3-20
Trouble-shooting guide .....	3-19
Warning signals .....	3-17
Interior light .....	2-45
Interior light replacement .....	8-31
ISOFIX child restraint .....	1-26

## J

Jump starting .....	6-10
---------------------	------

## K

Keyless entry	
With Intelligent Key system (See Intelligent Key system).....	3-20
Without Intelligent Key system (See remote keyless entry system).....	3-5
Keys, Except Intelligent Key .....	3-2
Keys, For Intelligent Key system .....	3-9

## L

Labels	
Air bag warning labels .....	1-51
Air conditioner specification label.....	9-13
Emission control information label.....	9-13
Engine serial number.....	9-12
F.M.V.S.S./C.M.V.S.S. certification label ....	9-12
Tire and Loading Information label ...	8-36, 9-13
Vehicle identification number (VIN) .....	9-11
Lane departure warning (LDW) switch .....	2-30

Lane departure warning (LDW) system .....	5-19
LATCH system .....	1-26
License plate, Installing front license plate.....	9-14
Lift gate .....	3-24
Light	
Air bag warning light .....	1-52
Bulb replacement.....	8-30
Fog light switch.....	2-28
Headlight switch .....	2-24
Headlights bulb replacement.....	8-31
Indicator lights .....	2-15
Interior light .....	2-45
Replacement.....	8-30
Room light .....	2-45
Vanity mirror light .....	2-47
Warning/indicator lights and audible reminders .....	2-10
Xenon headlights .....	2-23
Lights, Exterior and interior light replacement .....	8-31
Loading information (See vehicle loading information).....	9-15
Lock	
Door locks .....	3-3
Glove box lock.....	2-36
Lift gate lock .....	3-24
Power door lock .....	3-3
Low fuel warning light .....	2-12
Low tire pressure warning light.....	2-13
Low tire pressure warning system (See tire pressure monitoring system (TPMS)) .....	5-3
Luggage floor boxes.....	2-39

## M

Maintenance	
Battery.....	8-17
General maintenance .....	8-2
Inside the vehicle .....	8-4
Maintenance precautions .....	8-5
Maintenance requirements.....	8-2
Outside the vehicle .....	8-3
Seat belt maintenance.....	1-18
Under the hood and vehicle .....	8-4
Malfunction indicator lamp (MIL).....	2-16
Mechanical key (for Intelligent Key system) .....	3-23
Memory storage, Automatic drive positioner .....	3-32
Meters and gauges .....	2-3
Meters and gauges, Instrument brightness control.....	2-27
Mirror	
Automatic anti-glare inside mirror.....	3-30
Outside mirrors.....	3-31
Mobile entertainment system (MES) .....	4-55
Monitor, Rearview monitor .....	4-18

## N

Net, Cargo net.....	2-39
New vehicle break-in.....	5-45

## O

Odometer .....	2-4
----------------	-----

<b>Oil</b>	
Capacities and recommended fuel/lubricants .....	9-2
Changing engine oil and filter .....	8-13
Checking engine oil level .....	8-11
Engine oil .....	8-11
Engine oil viscosity .....	9-5
On-pavement and off-load driving precautions (for AWD models) .....	5-3
Operating the engine (Intelligent Key system) .....	3-14
Outside mirrors .....	3-31
Overheat, If your vehicle overheats .....	6-13
Owner's Manual/Service Manual order information .....	9-29

## P

<b>Parking</b>	
Brake check .....	8-23
Parking brake operation .....	5-18
Parking on hills .....	5-48
<b>Phone</b>	
Bluetooth® Hands-Free Phone System .....	4-41
Car phone or CB radio .....	4-65
<b>Power</b>	
Front seat adjustment .....	1-2
Power door lock .....	3-3
Power outlet .....	2-32
Power steering fluid .....	8-15
Power steering system .....	5-49
Power windows .....	2-41
Pre-tensioner seat belt system .....	1-50

<b>Precautions</b>	
Audio operation .....	4-27
Braking precautions .....	5-49
Child restraints .....	1-19
Cruise control .....	5-22
Driving safety .....	5-8
Lane departure warning (LDW) system .....	5-19
Maintenance .....	8-5
On-pavement and off-load driving .....	5-3
Seat belt usage .....	1-8
Supplemental restraint system .....	1-37
When starting and driving .....	5-2
Preview function (for Intelligent cruise control system) .....	5-45
Push starting .....	6-12

## R

<b>Radio</b>	
Car phone or CB radio .....	4-65
Steering wheel audio controls .....	4-40
Readiness for inspection/maintenance (I/M) test (US only) .....	9-27
Rear center seat belt .....	1-15
<b>Rear door lock</b>	
Child safety rear door lock .....	3-5
Rear power point .....	2-32
Rear seat adjustment .....	1-4
Rear window and outside mirror defroster switch .....	2-23
Rear window wiper and washer switch .....	2-22
Rearview monitor .....	4-18
Recorders, Event data .....	9-28
Registering your vehicle in another country .....	9-11

Remote controller (See INFINITI mobile entertainment system) .....	4-56
<b>Remote keyless entry</b>	
System, Except Intelligent Key system .....	3-5
System, For Intelligent Key system .....	3-20
Reporting safety defects (US only) .....	9-26
Roadside assistance program .....	6-2
Rollover .....	5-7
Room light .....	2-45
Run-flat tires .....	6-3

## S

<b>Safety</b>	
Child seat belts .....	1-11
Reporting safety defects (US only) .....	9-26
Towing safety .....	9-21
<b>Screen (See INFINITI mobile entertainment system) .....</b>	<b>4-57</b>
<b>Seat adjustment</b>	
Front power seat adjustment .....	1-2
Rear seat adjustment .....	1-4
<b>Seat belt(s)</b>	
Child safety .....	1-11
Infants .....	1-11
Injured persons .....	1-12
Larger children .....	1-12
Pre-tensioner seat belt system .....	1-50
Precautions on seat belt usage .....	1-8
Pregnant women .....	1-12
Rear center seat belt .....	1-15
Seat belt cleaning .....	7-5
Seat belt extenders .....	1-18
Seat belt maintenance .....	1-18

Seat belt warning light and chime .....	2-14
Seat belts .....	1-8
Shoulder belt height adjustment.....	1-15
Small children.....	1-11
Three-point type with retractor.....	1-12
Seat(s)	
Driver-side memory .....	3-32
Heated seats.....	2-29
Seats.....	1-2
Security system (INFINITI Vehicle Immobilizer System), Engine start .....	2-20
Security system, Vehicle security system .....	2-18
Selector lever, Shift lock release.....	5-17
Servicing air conditioner .....	4-21, 4-24
Shift lock release, Transmission .....	5-17
Shifting	
Automatic transmission.....	5-14
Shoulder belt height adjustment, For front seats .....	1-15
Snow mode switch .....	2-31
Spark plugs .....	8-20
Speedometer .....	2-4
Starting	
Before starting the engine .....	5-13
Jump starting .....	6-10
Precautions when starting and driving .....	5-2
Push starting .....	6-12
Starting the engine.....	5-14
Status light, Front passenger air bag .....	1-45
Steering	
Power steering fluid .....	8-15
Power steering system .....	5-49
Steering wheel switch for audio controls .....	4-40

Tilting telescopic steering column.....	3-28
Storage .....	2-34
Storage box .....	2-35
Sun shade .....	2-43
Sun visors .....	3-29
Sunglasses holder .....	2-34
Sunroof .....	2-43
Automatic sunroof.....	2-43
Supplemental air bag warning labels .....	1-51
Supplemental air bag warning light .....	1-52, 2-15
Supplemental restraint system .....	1-37
Precautions on supplemental restraint system.....	1-37
Switch	
Audio control steering wheel switch.....	4-40
Autolight switch .....	2-25
Fog light switch.....	2-28
Hazard warning flasher switch .....	2-28
Headlight aiming control .....	2-26
Headlight switch .....	2-24
Ignition switch (except Intelligent Key system).....	5-10
Ignition switch (with Intelligent Key system).....	5-12
Ignition switch automatic transmission models .....	5-14
Lane departure warning (LDW) system.....	2-30
Power door lock switch.....	3-4
Rear window and outside mirror defroster switch.....	2-23
Snow mode switch .....	2-31
Turn signal switch .....	2-28
Vehicle dynamic control (VDC) off switch....	2-31

## T

Tachometer .....	2-4
Temperature gauge	
Engine coolant temperature gauge.....	2-5
Theft (INFINITI Vehicle Immobilizer System)	
Engine start .....	2-20
Three-way catalyst .....	5-3
Tilting telescopic steering column .....	3-28
Tire	
Pressure, Low tire pressure warning light.....	2-13
Tires	
Flat tire .....	6-2
Low tire pressure warning system.....	5-3
Run-flat tires .....	6-3
Spare tire.....	8-45
Tire and Loading information label.....	8-36
Tire and Loading Information label .....	9-13
Tire chains .....	8-42
Tire dressing .....	7-3
Tire pressure.....	8-35
Tire pressure information (display).....	4-7, 4-15
Tire pressure monitoring system (TPMS).....	5-3, 6-2
Tire rotation .....	8-43
Types of tires .....	8-40
Uniform tire quality grading.....	9-25
Wheel/tire size.....	9-10
Wheels and tires .....	8-35
Tonneau cover .....	2-40
Top tether strap child restraints.....	1-27
Towing	
Flat towing .....	9-24

Tow truck towing.....	6-14
Towing a trailer.....	9-19
Towing load/specification chart.....	9-19
Towing safety.....	9-21
TPMS, Tire pressure monitoring system.....	5-3
TPMS, Tire pressure warning system.....	6-2
Trailer towing.....	9-19
Transceiver, HomeLink® Universal	
Transceiver.....	2-47
Transmission	
Automatic transmission fluid (ATF).....	8-15
Driving with automatic transmission.....	5-14
Transmission selector lever lock release....	5-17
Transmitter, With Intelligent Key system (See Intelligent Key system).....	3-20
Transmitter, Without Intelligent Key system (See remote keyless entry system).....	3-5
Traveling or registering your vehicle in another country.....	9-11
Trouble-shooting guide (for Intelligent Key system).....	3-19
Troubleshooting guide (for Bluetooth® Hands-Free Phone System).....	4-31, 4-54
Troubleshooting guide (for voice-activated control system).....	4-31, 4-54
Turn signal switch.....	2-28

## U

Underbody cleaning.....	7-3
Uniform tire quality grading.....	9-25

## V

Valet key (for Intelligent Key system).....	3-23
Vanity mirror light.....	2-47
Vehicle	
Dimensions and weights.....	9-10
Identification number (VIN).....	9-11
Loading information.....	9-15
Recovery (freeing a stuck vehicle).....	6-16
Security system.....	2-18
Vehicle dynamic control (VDC) off switch....	2-31
Vehicle dynamic control (VDC) system.....	5-54
Vehicle electronic systems.....	4-9, 4-16
Ventilators.....	4-20
Voice command (See Bluetooth® Hands-Free Phone System).....	4-47

## W

Warning labels, Air bag warning labels.....	1-51
Warning light	
Air bag warning light.....	1-52, 2-15
All-wheel drive (AWD) warning light.....	2-10
Anti-lock brake warning light.....	2-10
Brake warning light.....	2-11
Door open warning light.....	2-11
Low fuel warning light.....	2-12
Low tire pressure warning light.....	2-13
Seat belt warning light and chime.....	2-14
Warning lights.....	2-10
Warning, Hazard warning flasher switch.....	2-28
Warning, Lane departure warning (LDW) system.....	5-19

Warning, Tire pressure monitoring system (TPMS).....	5-3, 6-2
Warning, Warning/indicator lights and audible reminders.....	2-9
Warranty	
Emission control system warranty.....	9-26
Washer switch	
Rear window wiper and washer switch.....	2-22
Windshield wiper and washer switch.....	2-21
Washing.....	7-2
Waxing.....	7-2
Weights (See dimensions and weights).....	9-10
Wheel/tire size.....	9-10
Wheels and tires.....	8-35
Cleaning aluminum alloy wheels.....	7-3
Window washer fluid.....	8-16
Window(s)	
Cleaning.....	7-3
Power windows.....	2-41
Windshield wiper and washer switch.....	2-21
Wiper	
Rear window wiper and washer switch.....	2-22
Rear window wiper blade.....	8-23
Windshield wiper and washer switch.....	2-21
Wiper blades.....	8-21

## X

Xenon headlights.....	2-23
-----------------------	------

**MEMO**

10-8



**MEMO**

**MEMO**

10-10

**MEMO**

**MEMO**

10-12

**MEMO**

## GAS STATION INFORMATION

### FUEL RECOMMENDATION:

#### VK45DE engine

In order to maintain engine and exhaust system durability and performance, unleaded premium gasoline with an octane rating of at least 91 AKI (Anti-Knock Index) number (Research octane number 96) must be used.

If premium gasoline is not available, unleaded regular gasoline with an octane rating of 87 AKI number (Research octane number 91) may be temporarily used, but only under the following precautions:

- Have the fuel tank filled only partially with unleaded regular gasoline, and fill up with unleaded premium gasoline as soon as possible.
- Avoid full throttle driving and abrupt acceleration.

#### VQ35DE engine

Use unleaded regular gasoline with an octane rating of at least 87 AKI (Anti-Knock Index) number (Research octane number 91).

For improved vehicle performance, INFINITI recommends the use of unleaded premium gasoline with an octane rating of at least 91 AKI number (Research octane number 96).



### CAUTION

- **Using a fuel other than that specified could adversely affect the emission control systems, and may also affect warranty coverage.**
- **Under no circumstances should a leaded gasoline be used, since this will damage the three way catalyst.**
- **Do not use E-85 fuel in your vehicle. Your vehicle is not designed to run on E-85 fuel. Using E-85 fuel can damage the fuel system components and is not covered by the INFINITI vehicle limited warranty.**

For additional information, see “Capacities and recommended fuel/lubricants” in the “9. Technical and consumer information” section.

### ENGINE OIL RECOMMENDATION:

For VK45DE engine

- API Certification Mark
- API grade SJ or SL, Energy Conserving
- ILSAC grade GF-II & GF-III
- SAE 5W-30 viscosity oil is preferred for all ambient temperatures. SAE 10W-30,

10W-40 viscosity oil may be used for ambient temperatures above 0°F (–18°C).

For VQ35DE engine

- API Certification Mark
- API grade SG/SH, Energy Conserving I & II or API grade SJ or SL, Energy Conserving
- ILSAC grade GF-I, GF-II & GF-III
- SAE 5W-30 viscosity oil is preferred for all ambient temperatures. SAE 10W-30, 10W-40 viscosity oil may be used for ambient temperatures above 0°F (–18°C).

See “Capacities and recommended fuel/lubricants” in the “9. Technical and consumer information” section for engine oil and oil filter recommendation.

### COLD TIRE PRESSURES:

See Tire and Loading Information label affixed to the inside of the rear left door opening.

### NEW VEHICLE BREAK-IN PROCEDURES RECOMMENDATION:

During the first 1,200 miles (2,000 km) of vehicle use, follow the recommendations outlined in the “Break-in schedule” infor-

mation found in the “5. Starting and driving” section of this Owner’s Manual. Follow these recommendations for the future reliability and economy of your new vehicle.

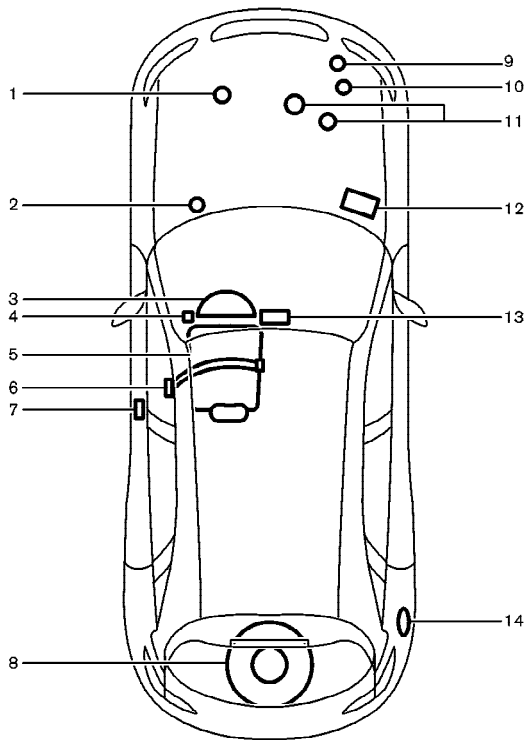

1. Engine oil (P.8-11)
2. Brake fluid (P.8-16)
3. Meters and gauges (P.2-3)
4. Hood release (P.3-24)
5. Lift gate (P.3-24)/Fuel-filler door release (P.3-26)
6. Seat belt (P.1-8)
7. Door lock/key (P.3-3)
8. Spare tire (P.6-2, P.8-43)
9. Windshield washer fluid (P.8-16)
10. Engine coolant (P.8-9)
11. Power steering fluid (P.8-15)
12. Battery (P.8-17)
13. Audio system (P.4-25)/Heater and air conditioner (P.4-21)
14. Fuel (P.3-26, P.9-2)