

FOREWORD

Your INFINITI represents a new way of thinking about vehicle design. It integrates advanced engineering and superior craftsmanship with a simple, refined aesthetic sensitivity associated with traditional Japanese culture.

The result is a different notion of luxury and beauty. The car itself is important, but so also is the sense of harmony that the vehicle evokes in its driver, and the sense of satisfaction you feel with the INFINITI —from the way it looks and drives to the high level of retailer service.

To ensure that you enjoy your INFINITI to the fullest, we encourage you to read this Owner's Manual immediately. It explains all of the features, controls and performance characteristics of your INFINITI; it also provides important instructions and safety information.

A separate Warranty Information Booklet is to be found in your Owner's literature portfolio. Always carry it with you when you take your INFINITI to an authorized retailer. The portfolio contents provide complete information about all warranties covering this vehicle, the periodic maintenance required to keep the warranties in effect as well as the INFINITI Roadside Assistance program.

Additionally, a separate Customer Care and Lemon Law Information Booklet will explain how to resolve any concerns you may have with your vehicle, as well as clarify your rights under your state's lemon law.

INFINITI is dedicated to providing a satisfying ownership experience for as long as you own your car. Should you have any questions regarding your INFINITI or your INFINITI retailer, please contact our Consumer Affairs department at 1-800-662-6200. In Hawaii 1-808-836-0848 (Oahu number). In Canada 1-800-361-4792. Thank you.

READ FIRST — THEN DRIVE SAFELY

Before driving your vehicle please read your Owner's Manual carefully. This will ensure familiarity with controls and maintenance requirements, assisting you in the safe operation of your vehicle.



WARNING

IMPORTANT SAFETY INFORMATION REMINDERS FOR SAFETY!

Follow these important driving rules to help ensure a safe and comfortable trip for you and your passengers!

- Never drive under the influence of alcohol or drugs.
- Always observe posted speed limits and never drive too fast for conditions.
- Always use your seat belts and appropriate child restraint systems. Preteen children should be seated in the rear seat.
- Always provide information about the proper use of vehicle safety

features to all occupants of the vehicle.

- Always review this Owner's Manual for important safety information.

MODIFICATION OF YOUR VEHICLE

This vehicle should not be modified. Modification could affect its performance, safety or durability, and may even violate governmental regulations. In addition, damage or performance problems resulting from modification may not be covered under INFINITI warranties.

WHEN READING THE MANUAL

This manual includes information for all options available on this model. There-

fore, you may find some information that does not apply to your vehicle.

All information, specifications and illustrations in this manual are those in effect at the time of printing. INFINITI reserves the right to change specifications or design at any time without notice.

IMPORTANT INFORMATION ABOUT THIS MANUAL

You will see various symbols in this manual. They are used in the following ways:



WARNING

This is used to indicate the presence of a hazard that could cause death or serious personal injury. To avoid or reduce the risk, the procedures must be followed precisely.



CAUTION

This is used to indicate the presence of a hazard that could cause minor or moderate personal injury or damage to your vehicle. To avoid or reduce the risk, the procedures must be followed carefully.

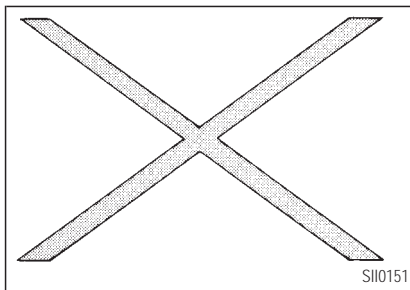

If you see this symbol, it means **Do not do this** or **Do not let this happen**.

CALIFORNIA PROPOSITION 65 WARNING



WARNING

Engine Exhaust, some of its constituents, and certain vehicle components contain or emit chemicals known to State of California to cause cancer and birth defects or other reproductive harm.



© 2002 NISSAN MOTOR CO., LTD.
TOKYO, JAPAN

All rights reserved. No part of this Owner's Manual may be reproduced or stored in a retrieval system, or transmitted in any form, or by any means, electronic, mechanical, photocopying, recording or otherwise, without the prior written permission of Nissan Motor Co., Ltd.

TABLE OF CONTENTS

SEATS, RESTRAINTS AND SUPPLEMENTAL AIR BAG SYSTEMS	1-1
INSTRUMENTS AND CONTROLS	2-1
PRE-DRIVING CHECKS AND ADJUSTMENTS.....	3-1
HEATER, AIR CONDITIONER AND AUDIO SYSTEMS	4-1
STARTING AND DRIVING.....	5-1
IN CASE OF EMERGENCY	6-1
APPEARANCE AND CARE.....	7-1
DO-IT-YOURSELF	8-1
MAINTENANCE	9-1
TECHNICAL AND CONSUMER INFORMATION	10-1
INDEX	11-1

1 SEATS, RESTRAINTS AND SUPPLEMENTAL AIR BAG SYSTEMS

Seats.....	1-2	Pregnant women	1-27
Front power seat adjustment	1-3	Injured persons	1-28
Folding rear seat	1-4	Three-point type seat belt with	
Head restraint adjustment.....	1-5	retractor.....	1-28
Active head restraint (Front seats).....	1-6	Seat belt extenders	1-31
Armrest.....	1-7	Seat belt maintenance	1-32
Supplemental restraint system.....	1-7	Child restraints	1-32
Precautions on supplemental restraint		Precautions on child restraints	1-32
system.....	1-7	Installation on rear seat center or outboard	
Supplemental air bag warning labels... 1-20		positions.....	1-34
Supplemental air bag warning light..... 1-20		LATCH (Lower Anchors and Tether for	
Seat belts	1-22	Children) System.....	1-39
Precautions on seat belt usage	1-22	Top tether strap child restraint	1-41
Child safety.....	1-26	Installation on front passenger seat....	1-42

SEATS, RESTRAINTS AND SUPPLEMENTAL AIR BAG SYSTEMS

SEATS

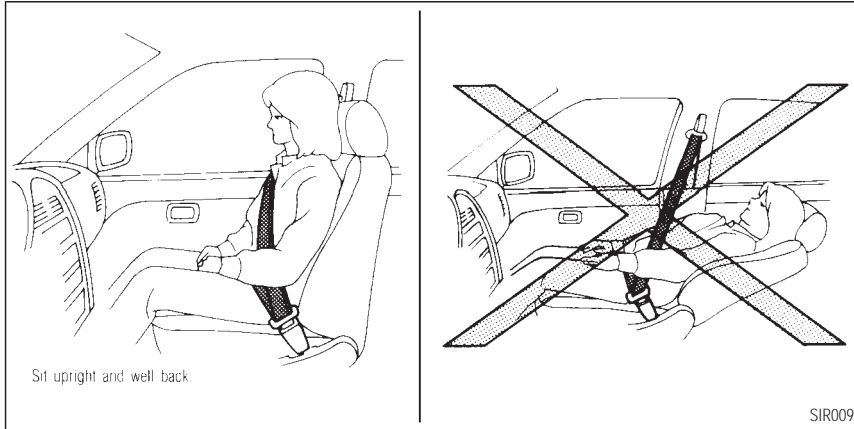

belt and receive serious internal injuries.

- *For most effective protection when the vehicle is in motion, the seat should be upright. Always sit well back in the seat and adjust the seat belt properly. See "Precautions on seat belt usage" later in this section.*



WARNING

- *Do not ride in a moving vehicle when the seatback is reclined. This can be dangerous. The*

shoulder belt will not be against your body. In an accident you could be thrown into it and receive neck or other serious injuries. You could also slide under the lap

SEATS, RESTRAINTS AND SUPPLEMENTAL AIR BAG SYSTEMS

FRONT POWER SEAT ADJUSTMENT

WARNING

- Do not adjust the driver's seat while driving so full attention may be given to vehicle operation.
- Do not leave children unattended inside the vehicle. They could unknowingly activate switches or controls. Unattended children could become involved in serious accidents.

For memory seat information see "Automatic drive positioner" in the "3. Pre-driving checks and adjustments" section.

Operating tips

- The motor has an auto-reset overload protection circuit. If the motor stops during

operation, wait 30 seconds, then reactivate the switch.

- Do not operate the power seat for a long period of time when the engine is off. This will discharge the battery.

Forward and backward

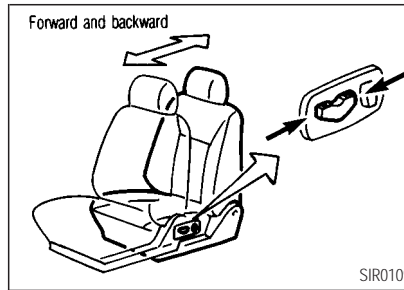

Moving the switch forward or backward will slide the seat forward or backward to the desired position.

Reclining

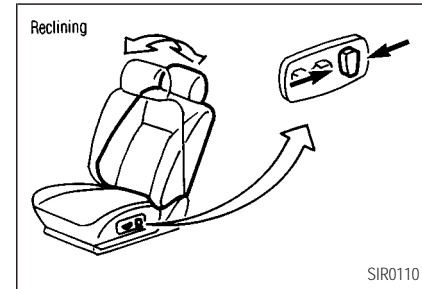

Move the recline switch backward until the desired angle is obtained. To bring the seatback forward again, move the switch forward and move your body forward. The seatback will move forward.

SEATS, RESTRAINTS AND SUPPLEMENTAL AIR BAG SYSTEMS

Seat lifter (Driver's seat)

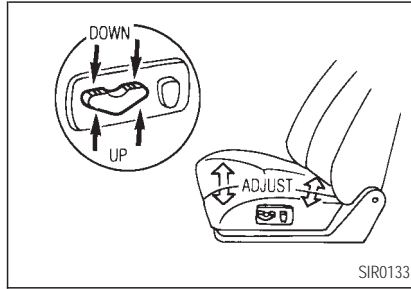

Push the front or rear end of the switch to adjust the angle and height of the seat cushion.

Lumbar support (Driver's seat)

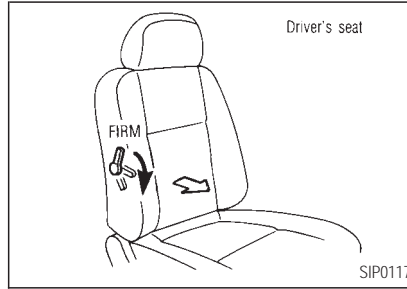

The lumbar support feature provides lower back support to the driver. Move the lever up or down to adjust the seat lumbar area.

FOLDING REAR SEAT

Interior trunk access

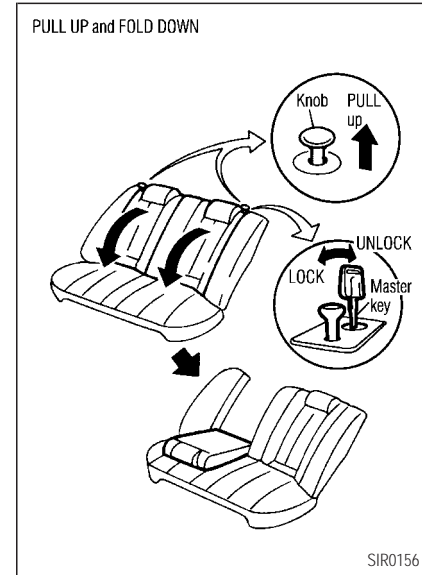

SEATS, RESTRAINTS AND SUPPLEMENTAL AIR BAG SYSTEMS

Pull up on the release knob to access the trunk from the rear seat.

The rear seats can be locked using the master key to prevent unauthorized access.



WARNING

- When returning the seatbacks to the upright position, be certain that they are completely secured in the latched position. If they are not completely secured in the latched position, passengers may be injured in an accident or sudden stop.
- Never allow anyone to ride in the luggage area or on the rear seat when it is in the fold-down position. Use of these areas by pas-

sengers without proper restraint can be extremely dangerous in an accident or sudden stop.

- Properly secure all cargo to help prevent it from sliding or shifting. Do not place cargo higher than the seatbacks. In a sudden stop or collision, unsecured cargo could cause personal injury.
- Closely supervise children when they are around cars to prevent them from playing and becoming locked in the trunk where they could be seriously injured. Keep the car locked with the rear seatback securely latched when not in use, and prevent children's access to car keys.

HEAD RESTRAINT ADJUSTMENT



WARNING

Head restraints should be adjusted properly as they may provide significant protection against injury in an accident. Do not remove them. Check the adjustment after someone else uses the seat.

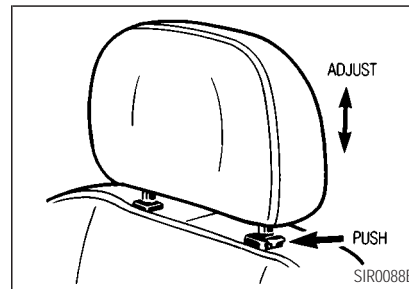

SEATS, RESTRAINTS AND SUPPLEMENTAL AIR BAG SYSTEMS

To raise the head restraint, simply pull it up.
To lower, push the lock knob and push the head restraint down.

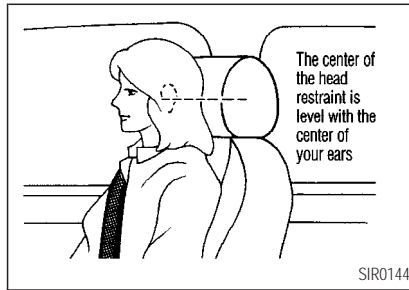

Adjust the head restraints so the center is level with the center of your ears.

ACTIVE HEAD RESTRAINT (Front seats)

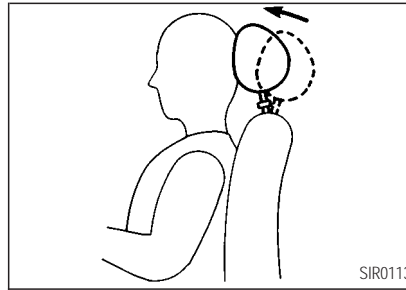

WARNING

- ***Always adjust the head restraints properly as specified in the previous section. Failure to do so can reduce the effectiveness of the active head restraint.***

- ***Active head restraints are designed to supplement other safety systems. Always wear seat belts. No system can prevent all injuries in any accident.***
- ***Do not attach anything to the head restraint stalks. Doing so could impair active head restraint function.***

The head restraint moves forward utilizing the force that the seatback receives from the occupant in a rear-end collision. The movement of the head restraint helps support the occupant's head by reducing its backward movement and helping absorb some of the forces that may lead to whiplash type injuries.

Active head restraints are effective for collisions at low to medium speeds in which it is said that whiplash injury occurs most.

SEATS, RESTRAINTS AND SUPPLEMENTAL AIR BAG SYSTEMS

Active head restraints operate only in certain rear-end collisions. After the collision, the head restraints return to their original positions.

Properly adjust the active head restraints as described in the previous section.

ARMREST

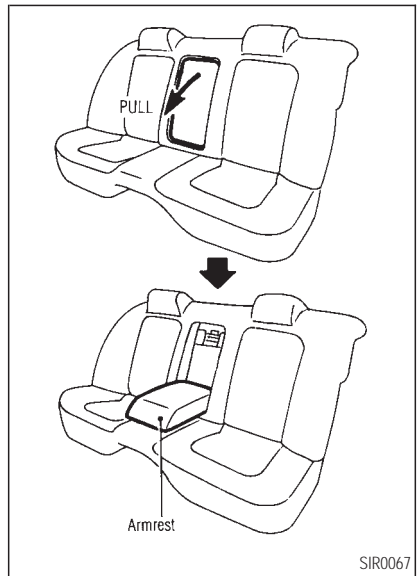

Pull the armrest forward until it is horizontal.

SUPPLEMENTAL RESTRAINT SYSTEM

PRECAUTIONS ON SUPPLEMENTAL RESTRAINT SYSTEM

This Supplemental Restraint System (SRS) section contains important information concerning the driver and passenger supplemental front air bags and supplemental side air bags and pre-tensioner seat belt.

Supplemental front air bag system: This system can help cushion the impact force to the face and chest of the driver and front passenger in certain frontal collisions.

Supplemental side air bag system: This system can help cushion the impact force to the head and the chest area of the driver and front passenger in certain side impact collisions. The supplemental side air bag is designed to inflate on the side where the vehicle is impacted.

These supplemental restraint systems are de-

SEATS, RESTRAINTS AND SUPPLEMENTAL AIR BAG SYSTEMS

signed to **supplement** the crash protection provided by the driver and front passenger seat belts and are **not a substitute** for them. Seat belts should always be correctly worn and the driver and front passenger seated a suitable distance away from the steering wheel, instrument panel and front door finishers. (See "Seat belts" later in this section for instructions and precautions on seat belt usage.)

After turning the ignition key to the ON position, the supplemental air bag warning light illuminates. The supplemental air bag warning light will turn off after about 7 seconds if the system is operational.

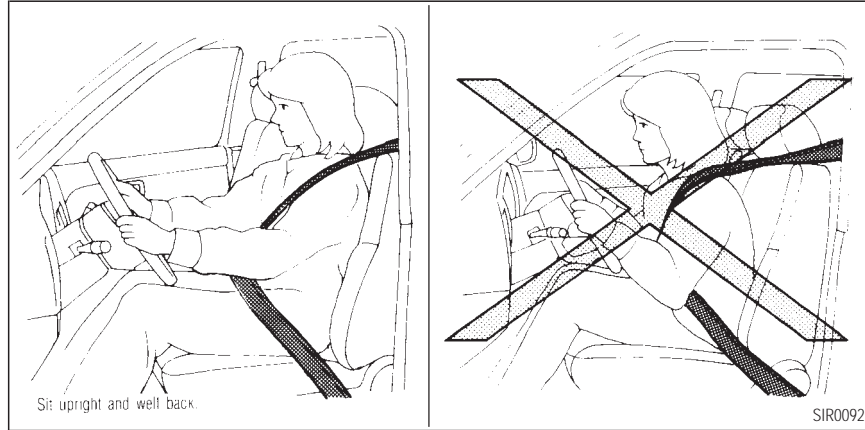

WARNING

- *The supplemental front air bags ordinarily will not inflate in the event of a side impact, rear im-*

pact, roll over, or lower severity frontal collision. Always wear your seat belts to help reduce the risk or severity of injury in various kinds of accidents.

SEATS, RESTRAINTS AND SUPPLEMENTAL AIR BAG SYSTEMS

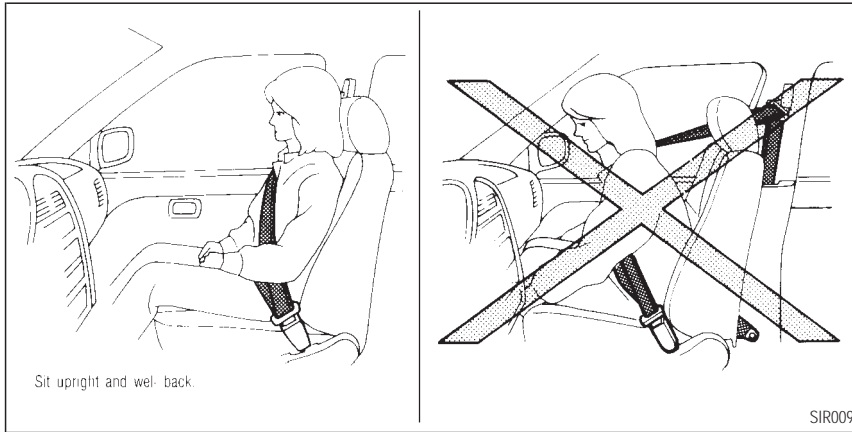

- The seat belts and the supplemental front air bags are most effective when you are sitting well back and upright in the seat. Front air bags inflate with great force.

If you are unrestrained, leaning forward, sitting sideways or out of position in any way, you are at greater risk of injury or death in a crash. You may also receive

serious or fatal injuries from the supplemental front air bag if you are up against it when it inflates. Always sit back against the seat-back and as far away as practical from the steering wheel or instrument panel. Always use the seat belts.

- The driver and front passenger seat belt buckles are equipped with sensors that detect if the seat belts are fastened. The air bag system monitors the severity of a collision and then inflates the air bags based on belt usage. Failure to properly wear seat belts can increase the risk or severity of injury in an accident.
- Keep hands on the outside of the steering wheel. Placing them in-

SEATS, RESTRAINTS AND SUPPLEMENTAL AIR BAG SYSTEMS

side the steering wheel rim could increase the risk that they are injured when the supplemental front air bag inflates.

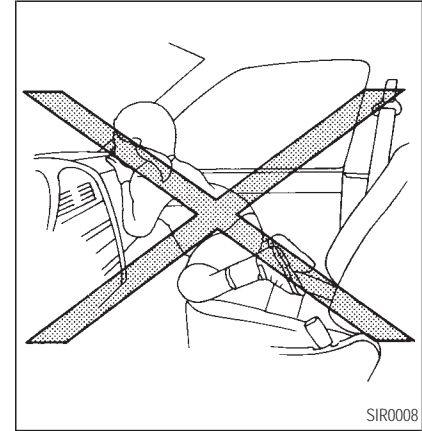
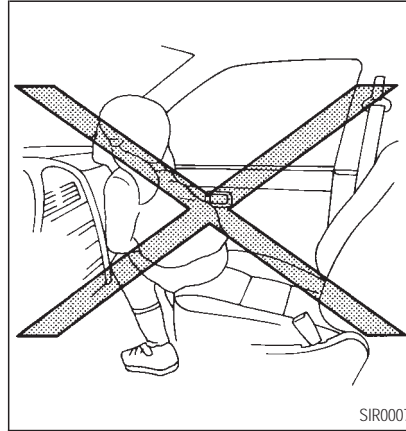
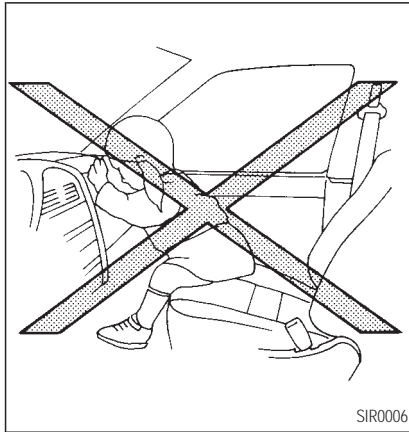

SEATS, RESTRAINTS AND SUPPLEMENTAL AIR BAG SYSTEMS

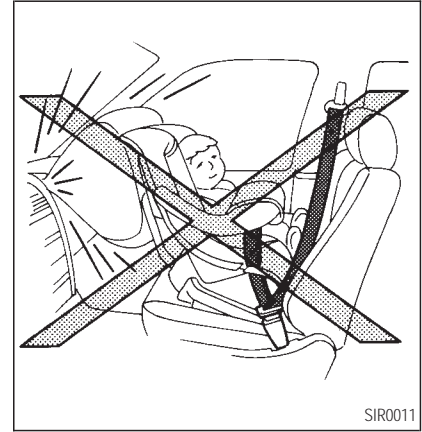
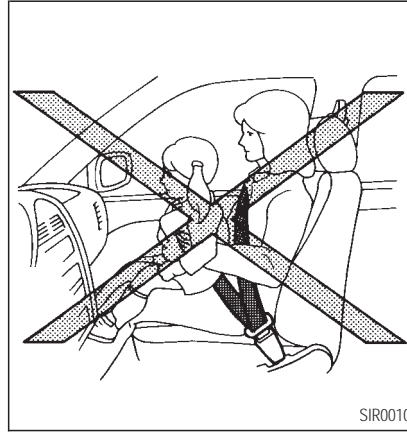
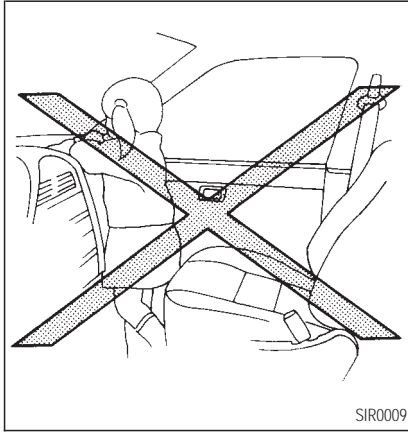

SEATS, RESTRAINTS AND SUPPLEMENTAL AIR BAG SYSTEMS

WARNING

- Never let children ride unrestrained or extend their hands or face out of the window. Do not attempt to hold them in your lap or arms. Some examples of dangerous riding positions are shown in the previous illustrations.
- Children may be severely injured or killed when the supplemental front air bag or supplemental side air bag inflates if they are not properly restrained. Preteens and children should be properly restrained in the rear seat if possible.
- Also never install a rear facing child restraint in the front seat.

An inflating supplemental front air bag could seriously injure or kill your child. For additional information, see "Child restraints" later in this section.



WARNING

Supplemental side air bag

- The supplemental side air bag ordinarily will not inflate in the

SEATS, RESTRAINTS AND SUPPLEMENTAL AIR BAG SYSTEMS

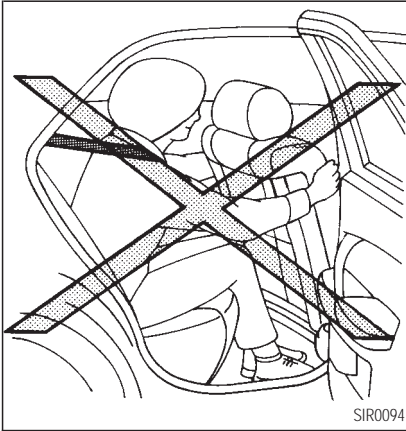

event lower severity side collision. Always wear your seat belts to help reduce the risk or severity of injury in various kinds of accidents.

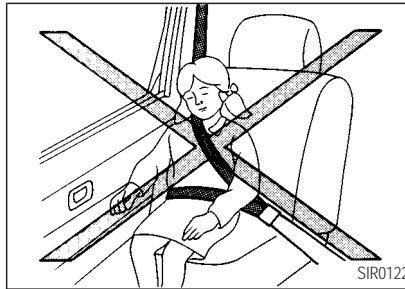
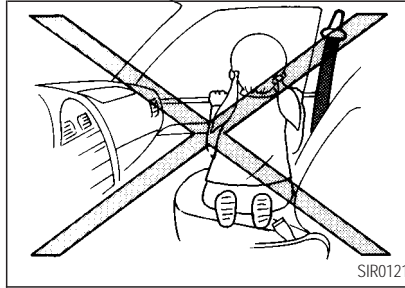

- The seat belts and the supplemental side air bag are most effective when you are sitting well back and upright in the seat. The side air bag inflates with great force. Do not allow anyone to place their hand, leg or face near the side air bag on the side of the seatback of the front seat. Do not allow anyone sitting in the front seat to extend their hand out of the window or lean against the door. Some examples of dangerous riding positions are shown in the previous illustrations.
- When sitting in the rear seat, do not hold onto the seatback of the front seat. If the supplemental side air bag inflates, you may be seriously injured. Be es-

SEATS, RESTRAINTS AND SUPPLEMENTAL AIR BAG SYSTEMS

pecially careful with children, who should always be properly restrained.

- *Do not use seat covers on the front seatbacks. They may interfere with supplemental side air bag inflation.*

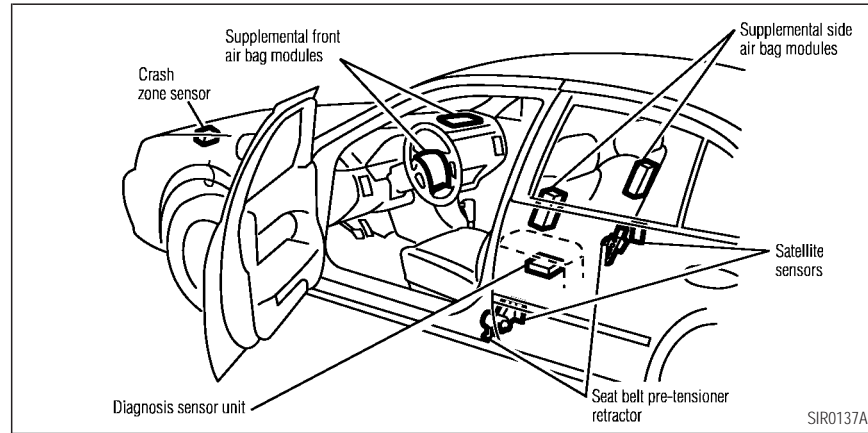

Supplemental front air bag system

The driver supplemental air bag is located in the center of the steering wheel; the front passenger supplemental air bag is mounted in the dashboard above the glove box. These systems are designed to meet optional certi-

fication requirements under U.S. regulations. They are also permitted in Canada. The optional certification allows front air bags to be designed to inflate somewhat less forcefully than previously. **However, all of the information, cautions and warnings in this manual still apply and must be followed.** The front air bags are designed to

SEATS, RESTRAINTS AND SUPPLEMENTAL AIR BAG SYSTEMS

inflate in higher severity frontal collisions, although they may inflate if the forces in another type of collision are similar to those of a higher severity frontal impact. They may not inflate in certain frontal collisions. Vehicle damage (or lack of it) is not always an indication of proper supplemental air bag operation.

The supplemental air bag system has dual stage inflators for both the driver and passenger air bags. The system monitors information from the crash zone sensor, the diagnosis sensor unit and seat belt buckle sensors that detect if the seat belts are fastened, inflator operation is based on the severity of a collision and whether the seat belts are being used.

When the supplemental front air bag inflates, a fairly loud noise may be heard, followed by release of smoke. This smoke is not harmful and does not indicate a fire. Care should be taken not to inhale it, as it may cause irritation

and choking. Those with a history of a breathing condition should get fresh air promptly.

Supplemental front air bags, along with the use of seat belts, help to cushion the impact force on the face and chest of the front occupants. They can help save lives and reduce serious injuries. However, an inflating front air bag may cause facial abrasions or other injuries. Front air bags do not provide restraint to the lower body.

The seat belts should be correctly worn and the driver and passenger seated upright as far as practical away from the steering wheel or dash board. The supplemental front air bags inflate quickly in order to help protect the front occupants. Because of this, the force of the front air bag inflating can increase the risk of injury if the occupant is too close to, or is against, the air bag module during inflation. The air bag will deflate quickly after the collision is over.

After turning the ignition key to the ON position, the supplemental air bag warning light illuminates. The supplemental air bag warning light will turn off after about 7 seconds if the system is operational.



WARNING

- *Do not place any objects on the steering wheel pad or on the instrument panel. Also, do not place any objects between any occupant and the steering wheel or instrument panel. Such objects may become dangerous projectiles and cause injury if the supplemental front air bag inflates.*
- *Right after inflation, several air bag system components will be hot. Do not touch them; you may*

SEATS, RESTRAINTS AND SUPPLEMENTAL AIR BAG SYSTEMS

severely burn yourself.

- No unauthorized changes should be made to any components or wiring of the supplemental front air bag system. This is to prevent accidental inflation of the air bag or damage to the air bag system.
- Do not make unauthorized changes to your vehicle's electrical system, suspension system or front end structure. This could affect proper operation of the supplemental air bag system.
- Tampering with the supplemental front air bag system may result in serious personal injury. Tampering includes changes to the steering wheel and the instrument panel assembly by placing material over the steering wheel pad

and above the dashboard, or by installing additional trim material around the air bag system.

- Work around and on the supplemental front air bag system should be done by an authorized INFINITI retailer. Installation of electrical equipment should also be done by an authorized INFINITI retailer. The SRS wiring harnesses* should not be modified or disconnected. Unauthorized electrical test equipment and probing devices should not be used on the air bag system.
- * The SRS wiring harnesses are covered with yellow insulation either just before the harness connectors or over the complete harness for easy identification.

- A cracked windshield should be replaced immediately by a qualified repair facility. A cracked windshield could affect inflation of the supplemental air bag system.

When selling your vehicle, we request that you inform the buyer about the supplemental front air bag system and guide the buyer to the appropriate sections in this Owner's Manual.

Supplemental side air bag system

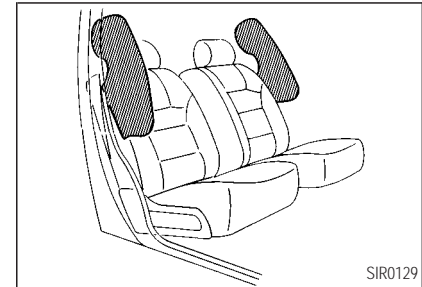

SIR0129

SEATS, RESTRAINTS AND SUPPLEMENTAL AIR BAG SYSTEMS

The supplemental side air bags are located in the outside of the seatback of the front seats. The supplemental side air bag (on the driver or front passenger seat) is designed to inflate in higher severity side collisions, although it may inflate if the forces in another type of collision are similar to those of a higher severity side impact. It is designed to inflate on the side where the vehicle is impacted. It may not inflate in certain side collisions. Vehicle damage (or lack of it) is not always an indication of proper supplemental side air bag operation.

When the supplemental side air bag inflates, a fairly loud noise may be heard, followed by release of smoke. This smoke is not harmful and does not indicate a fire. Care should be taken not to inhale it, as it may cause irritation and choking. Those with a history of a breathing condition should get fresh air promptly.

Supplemental side air bags, along with the use of seat belts, help to cushion the impact force on the head and the chest of the front occupants. They can help save lives and

reduce serious injuries. However, an inflating side air bag may cause abrasions or other injuries. Supplemental side air bags do not provide restraint to the lower body.

The seat belts should be correctly worn and the driver and passenger seated upright as far as practical away from supplemental side air bag. The side air bags inflate quickly in order to help protect the front occupants. Because of this, the force of the side air bag inflating can increase the risk of injury if the occupant is too close to, or is against, the side air bag module during inflation. The side air bag will deflate quickly after the collision is over.

After turning the ignition key to the ON position, the supplemental air bag warning light illuminates. The supplemental air bag warning light will turn off after about 7 seconds if the system is operational.



WARNING

- *Do not place any objects near the seatback of the front seats. Also, do not place any objects (an umbrella, bag, etc.) between the front door finisher and the front seat. Such objects may become dangerous projectiles and cause injury if the supplemental side air bag inflates.*
- *Right after inflation, several supplemental side air bag system components will be hot. Do not touch them; you may severely burn yourself.*
- *No unauthorized changes should be made to any components or wiring of the supplemental side*

SEATS, RESTRAINTS AND SUPPLEMENTAL AIR BAG SYSTEMS

air bag system. This is to prevent accidental inflation of the side air bag or damage to the side air bag system.

- *Do not make unauthorized changes to your vehicle's electrical system, suspension system or side panel. This could affect proper operation of the side air bag system.*
- *Tampering with the supplemental side air bag system may result in serious personal injury. For example, do not change the front seat assembly by placing material near the seatback of the front seat, or by installing additional trim material, such as seat covers, around the side air bag system.*

- *Work around and on the supplemental side air bag system should be done by an authorized INFINITI retailer. Installation of electrical equipment should also be done by an authorized INFINITI retailer.*

The SRS wiring harnesses should not be modified or disconnected. Unauthorized electrical test equipment and probing devices should not be used on the side air bag system.*

- * *The SRS wiring harnesses are covered with yellow insulation either just before the harness connectors or over the complete harness for easy identification.*

When selling your vehicle, we request that you inform the buyer about the supplemental side

air bag system and guide the buyer to the appropriate sections in this Owner's Manual.

Pre-tensioner seat belt system (For front seats)



WARNING

- *The pre-tensioner seat belt cannot be reused after activation. It must be replaced together with the retractor as a unit.*
- *If the vehicle becomes involved in a frontal collision but the pre-tensioner is not activated, be sure to have the pre-tensioner system checked and, if necessary, replaced by your INFINITI retailer.*
- *No unauthorized changes should be made to any components or wiring of the pre-tensioner seat*

SEATS, RESTRAINTS AND SUPPLEMENTAL AIR BAG SYSTEMS

belt system. This is to prevent accidental activation of the pre-tensioner seat belt or damage to the pre-tensioner seat belt operation. Tampering with the pre-tensioner seat belt system may result in serious personal injury.

- *Work around and on the pre-tensioner system should be done by an authorized INFINITI retailer. Installation of electrical equipment should also be done by an authorized INFINITI retailer. Unauthorized electrical test equipment and probing devices should not be used on the pre-tensioner seat belt system.*
- *If you need to dispose of the pre-tensioner or scrap the vehicle, contact an authorized*

INFINITI retailer. Correct pre-tensioner disposal procedures are set forth in the appropriate INFINITI Service Manual. Incorrect disposal procedures could cause personal injury.

The front seat pre-tensioner seat belt system activates in conjunction with the supplemental front air bag. Working with the seat belt retractor, it helps tighten the seat belt the instant the vehicle becomes involved in certain types of collisions, thereby restraining seat occupants.

The pre-tensioner is encased with the seat belt's retractor. These seat belts are used the same as conventional seat belts.

When the pre-tensioner seat belt activates, smoke is released and a loud noise may be heard. The smoke is not harmful, but care should be taken not to inhale it as it may

cause irritation and choking. Those with a history of a breathing condition should get fresh air promptly.

If any abnormality occurs in the pre-tensioner system, the supplemental air bag warning light  will not come on, will flash intermittently or will turn on for 7 seconds and remain on after the ignition key has been turned to the ON or START position. In this case, the pre-tensioner seat belt may not function properly.

When selling your vehicle, we request that you inform the buyer about the pre-tensioner seat belt system and guide the buyer to the appropriate sections in this Owner's Manual.

SEATS, RESTRAINTS AND SUPPLEMENTAL AIR BAG SYSTEMS

SUPPLEMENTAL AIR BAG WARNING LABELS

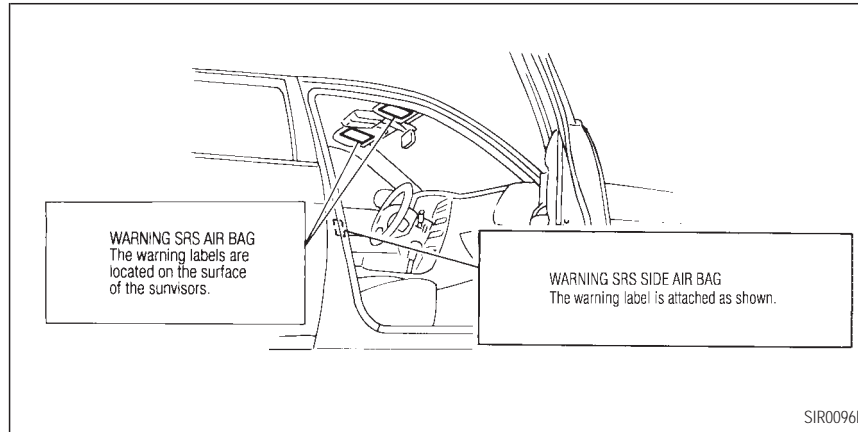

Warning labels about the supplemental air bag system are placed in the vehicle as shown in the illustration.

SUPPLEMENTAL AIR BAG WARNING LIGHT



The supplemental air bag warning light, displaying  in the instrument panel, monitors the circuits of the supplemental front air bag system, supplemental side air bag system, and pre-tensioner seat belt. The circuits monitored by the air bag warning light are the diagnosis sensor unit, satellite sensors, front air bag modules, side air bag modules and all related wiring, and pre-tensioner seat belt.

After turning the ignition key to the ON

SEATS, RESTRAINTS AND SUPPLEMENTAL AIR BAG SYSTEMS

position, the supplemental air bag warning light illuminates. The supplemental air bag warning light will turn off after about 7 seconds if the system is operational.

If any of the following conditions occur, the supplemental front air bag system, supplemental side air bag system, and pre-tensioner seat belt need servicing:

- The supplemental air bag warning light remains on after approximately 7 seconds.
- The supplemental air bag warning light flashes intermittently.
- The supplemental air bag warning light does not come on at all.

Under these conditions, the supplemental front air bags, supplemental side air bags and/or pre-tensioner seat belt may not operate properly. They must be checked and repaired. Take your vehicle to the nearest authorized INFINITI retailer.



WARNING

If the supplemental air bag warning light is on, it could mean that the supplemental front air bag system, supplemental side air bag system and/or pre-tensioner seat belt will not operate in an accident.

Repair and replacement procedure

The supplemental front air bags, supplemental side air bags and pre-tensioner seat belt are designed to inflate on a one-time-only basis. As a reminder, unless it is damaged, the supplemental air bag warning light will remain illuminated after inflation has occurred. Repair and replacement of these systems should be done only by authorized INFINITI retailers.

When maintenance work is required on the vehicle, the supplemental front air bags,

supplemental side air bags, related parts and pre-tensioner seat belt should be pointed out to the person conducting the maintenance. The ignition key should always be in the LOCK position when working under the hood or inside the vehicle.



WARNING

- ***Once the supplemental front air bag, supplemental side air bag and/or pre-tensioner seat belt have activated, the air bag module will not function again and must be replaced, additionally, if any of the supplemental air bags inflate, the pre-tensioner seat belts must also be replaced. The module should be replaced by an authorized INFINITI retailer. The supplemental front air bag module or supplemental side air bag mod-***

SEATS, RESTRAINTS AND SUPPLEMENTAL AIR BAG SYSTEMS

ule cannot be repaired.

- *The supplemental front air bag system, supplemental side air bag system and pre-tensioner seat belt should be inspected by an authorized INFINITI retailer if there is any damage to the front end or side portion of the vehicle.*
- *If you need to dispose of these supplemental systems or scrap the vehicle, contact an authorized INFINITI retailer.*

Correct disposal procedures are set forth in the appropriate INFINITI Service Manual. Incorrect disposal procedures could cause personal injury.

SEAT BELTS

PRECAUTIONS ON SEAT BELT USAGE

Your chances of being injured or killed in an accident and/or the severity of injury may be greatly reduced if you are wearing your seat belt and it is properly adjusted. INFINITI strongly encourages you and all of your passengers to buckle up every time you drive, even if your seating position includes a supplemental air bag.

Most states, provinces or territories require that seat belts be worn at all times when a vehicle is being driven.

SEATS, RESTRAINTS AND SUPPLEMENTAL AIR BAG SYSTEMS

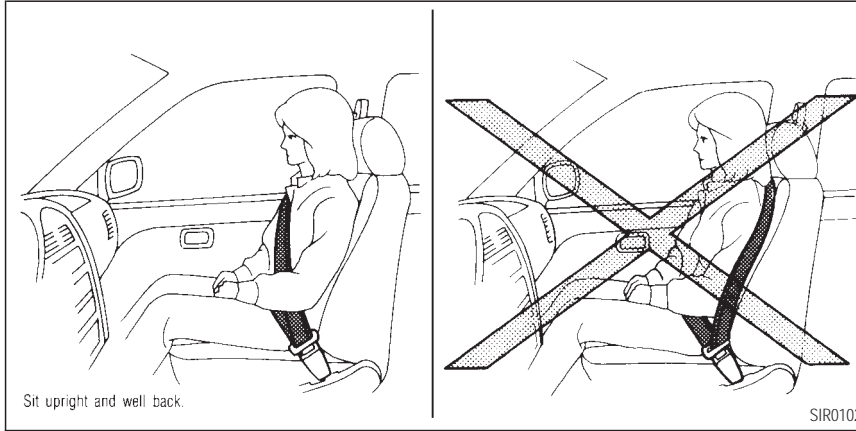

SEATS, RESTRAINTS AND SUPPLEMENTAL AIR BAG SYSTEMS

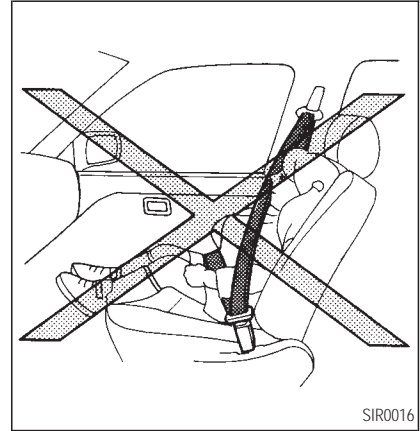
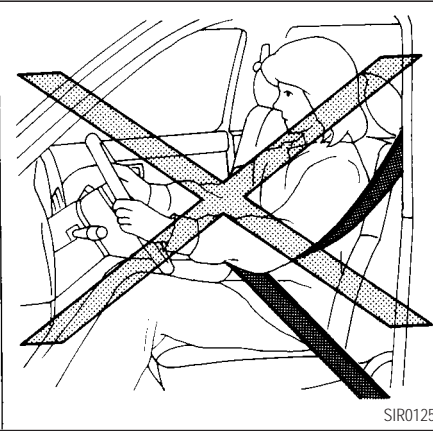

SEATS, RESTRAINTS AND SUPPLEMENTAL AIR BAG SYSTEMS

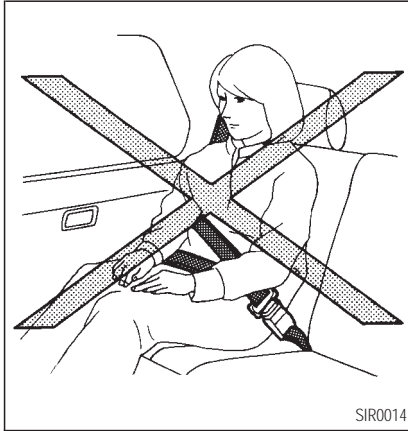

WARNING

- Every person who drives or rides in this vehicle should use a seat belt at all times. Children should be properly restrained in the rear seat and, if appropriate, in a child restraint.
- The belt should be properly adjusted to a snug fit. Failure to do so may reduce the effectiveness of the entire restraint system and increase the chance or severity of injury in an accident. Serious injury or death can occur if the seat belt is not worn properly.
- Always route the shoulder belt over your shoulder and across your chest. Never run the belt behind your back, under your arm or across your neck. The belt should be away from your face and neck, but not falling off your shoulder.
- Position the lap belt as low and snug as possible around the hips, not the waist. A lap belt worn too high could increase the risk of internal injuries in an accident.
- Be sure the seat belt tongue is securely fastened to the proper buckle.
- Do not wear the belt inside out or twisted. Doing so may reduce its effectiveness.
- Do not allow more than one person to use the same belt.
- Never carry more people in the

SEATS, RESTRAINTS AND SUPPLEMENTAL AIR BAG SYSTEMS

vehicle than there are seat belts.

- *If the seat belt warning light glows continuously while the ignition is turned ON with all doors closed and all seat belts fastened, it may indicate a malfunction in the system. Have the system checked by your INFINITI retailer.*
- *Once the pre-tensioner seat belt has activated, it cannot be reused and must be replaced together with the retractor. See your INFINITI retailer.*
- *Removal and installation of the pre-tensioner seat belt system components should be done by an authorized INFINITI retailer.*
- *All seat belt assemblies including*

retractors and attaching hardware should be inspected after any collision by your INFINITI retailer. INFINITI recommends that all seat belt assemblies in use during a collision be replaced unless the collision was minor and the belts show no damage and continue to operate properly. Seat belt assemblies not in use during a collision should also be inspected and replaced if either damage or improper operation is noted.

- *All child restraints and attaching hardware should be inspected after any collision. Always follow the restraint manufacturer's inspection instructions and replacement recommendations. The child restraints should be re-*

placed if they are damaged.

CHILD SAFETY

Children need adults to help protect them. They need to be properly restrained.

The proper restraint depends on the child's size. Generally, infants [up to about 1 year and less than 20 lb (9 kg)] should be placed in rear facing child restraints. Front facing child restraints are available for children who outgrow rear facing child restraints.



WARNING

Infants and children need special protection. The vehicle's seat belts may not fit them properly. The shoulder belt may come too close to the face or neck. The lap belt may not fit

SEATS, RESTRAINTS AND SUPPLEMENTAL AIR BAG SYSTEMS

over their small hip bones. In an accident, an improperly fitting seat belt could cause serious or fatal injury. Always use appropriate child restraints.

All US states and provinces of Canada require the use of approved child restraints for infants and small children. (See “Child restraints” later in this section.)

In addition, there are many types of child restraints available for larger children which should be used for maximum protection.

INFINITI recommends that all preteens and children be restrained in the rear seat if possible. According to accident statistics, children are safer when properly restrained in the rear seat than in the front seat. This is especially important because your vehicle has a supplemental restraint system (air bag sys-

tem) for the front passenger. (See “Supplemental restraint system” earlier in this section for precautions.)

Infants and small children

INFINITI recommends that infants and small children be placed in child restraints that comply with Federal Motor Vehicle Safety Standards or Canadian Motor Vehicle Safety Standards. You should choose a child restraint that fits your vehicle and always follow the manufacturer's instructions for installation and use.

Larger children

Children who are too large for child restraints should be seated and restrained by the seat belts which are provided.

If the child's seating position has a shoulder belt that fits close to the face or neck, the use of a booster seat (commercially available) may help overcome this. The booster seat should raise the child so that the shoulder belt is

properly positioned across the top, middle portion of the shoulder and the lap belt is low on the hips. The booster seat should fit the vehicle seat and have a label certifying that it complies with Federal Motor Vehicle Safety Standards or Canadian Motor Vehicle Safety Standards. Once the child has grown so the shoulder belt is no longer on or near the face and neck, use the shoulder belt without the booster seat.



WARNING

Never let a child stand or kneel on any seat and do not allow a child in the cargo areas while the vehicle is moving. The child could be seriously injured or killed in an accident or a sudden stop.

PREGNANT WOMEN

INFINITI recommends that pregnant women

SEATS, RESTRAINTS AND SUPPLEMENTAL AIR BAG SYSTEMS

use seat belts. The seat belt should be worn snug, and always position the lap belt as low as possible around the hips, not the waist. Place the shoulder belt over your shoulder and across your chest. Never run the lap/shoulder belt over your abdominal area. Contact your doctor for specific recommendations.

INJURED PERSONS

INFINITI recommends that injured persons use seat belts, depending on the injury. Check with your doctor for specific recommendations.

THREE-POINT TYPE SEAT BELT WITH RETRACTOR



WARNING

- *Every person who drives or rides in this vehicle should use a seat*

belt at all times.

- *Do not ride in a moving vehicle when the seatback is reclined. This can be dangerous. The shoulder belt will not be against your body. In an accident you could be thrown into it and receive neck or other serious injuries. You could also slide under the lap belt and receive serious internal injuries.*
- *For most effective protection when the vehicle is in motion, the seat should be upright. Always sit well back in the seat and adjust the seat belt properly.*

Fastening the seat belts

1. Adjust the seat.

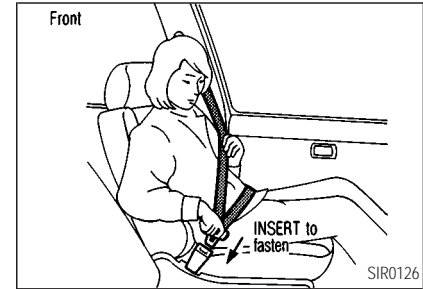

SEATS, RESTRAINTS AND SUPPLEMENTAL AIR BAG SYSTEMS



2. Slowly pull the seat belt out of the retractor and insert the tongue into the buckle until it snaps.

The retractor is designed to lock during a sudden stop or on impact. A slow pulling motion will permit the belt to move,

and allow you some freedom of movement in the seat.

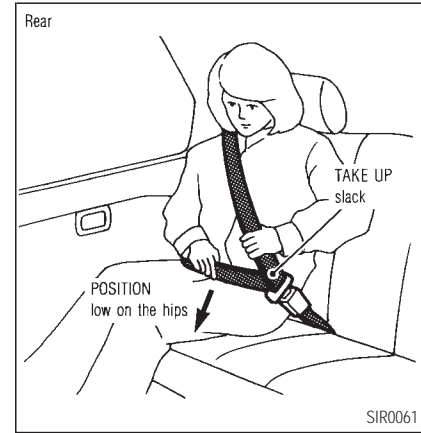
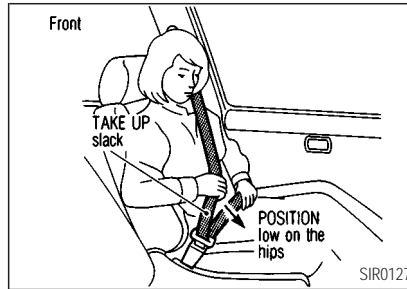

3. Position the lap belt portion **low and snug on the hips** as shown.
4. Pull the shoulder belt portion toward the retractor to take up extra slack.

The front passenger and rear seat belts have a cinching mechanism for child restraint instal-

SEATS, RESTRAINTS AND SUPPLEMENTAL AIR BAG SYSTEMS

lation. It is referred to as the automatic locking mode.

When the cinching mechanism is activated the seat belt cannot be withdrawn again until the seat belt tongue is detached from the buckle and fully retracted. For additional information, see "Child restraints" later in this section.

The automatic locking mode should be used only for child restraint installation. During normal seat belt use by a passenger, the locking mode should not be activated. If it is activated it may cause uncomfortable seat belt tension.



WARNING

When fastening the seat belts, be certain that seatbacks are completely secured in the latched position. If they are not completely secured in

the right position, passengers may be injured in an accident or sudden stop.

Unfastening the seat belts

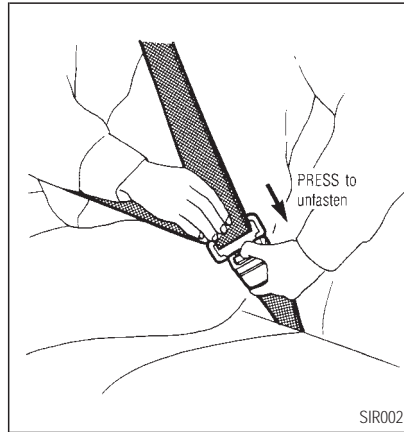

To unfasten the belt, press the button on the

buckle. The seat belt will automatically retract.

Checking seat belt operation

Your seat belt retractors are designed to lock belt movement using two separate methods:

- when the belt is pulled quickly from the retractor.
- when the vehicle slows down rapidly.

To increase your confidence in the belts, check their operation as follows:

- grasp the shoulder belt and pull quickly forward. The retractor should lock and restrict further belt movement.

If the retractor does not lock during this check or if you have any questions about belt operation, see your INFINITI retailer.

SEATS, RESTRAINTS AND SUPPLEMENTAL AIR BAG SYSTEMS

Shoulder belt height adjustment (For front seats)

The shoulder belt anchor height should be adjusted to the position best for you. (See “Precautions on seat belt usage” earlier in this section.)

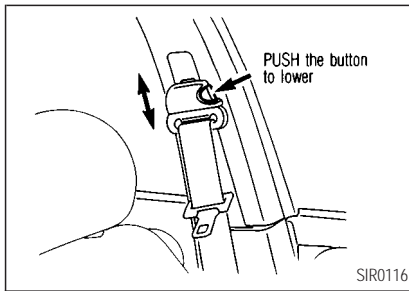

The shoulder belt anchor height should be adjusted to the position best suited for you. (See “Precautions on seat belt usage” earlier in this section.) To lower, push the release button, and then move the shoulder belt anchor to the desired position, so that the belt

passes over the shoulder. Release the adjustment button to lock the shoulder belt anchor into position.

To raise, move the adjuster up to the desired position without pushing the button.



WARNING

- *After adjustment, release the button and try to move the shoulder belt anchor down to make sure it is securely fixed in position.*
- *The shoulder belt anchor height should be adjusted to the position best for you. Failure to do so may reduce the effectiveness of the entire restraint system and increase the chance or severity of injury in an accident.*

SEAT BELT EXTENDERS

If, because of body size or driving position, it is not possible to properly fit the lap-shoulder belt and fasten it, an extender is available which is compatible with the installed seat belts. The extender adds approximately 8 inches (200 mm) of length and may be used for either the driver or front passenger seating position. See your INFINITI retailer for assistance if the extender is required.



WARNING

- *Only INFINITI belt extenders, made by the same company which made the original equipment belts, should be used with INFINITI belts.*
- *Adults and children who can use the standard seat belt should not use an extender. Such unneces-*

SEATS, RESTRAINTS AND SUPPLEMENTAL AIR BAG SYSTEMS

sary use could result in serious personal injury in the event of an accident.

- *Never use seat belt extenders to install child restraints. If the child restraint is not secured properly, the child could be seriously injured in a collision or a sudden stop.*

SEAT BELT MAINTENANCE

- To clean the seat belt webbings, apply a mild soap solution or any solution recommended for cleaning upholstery or carpets. Then brush the webbing, wipe it with a cloth and allow it to dry in the shade. Do not allow the seat belts to retract until they are completely dry.
- If dirt builds up in the shoulder belt guide of the seat belt anchors, the seat belts may

retract slowly. Wipe the shoulder belt guide with a clean, dry cloth.

- Periodically check to see that the seat belt and the metal components such as buckles, tongues, retractors, flexible wires and anchors work properly. If loose parts, deterioration, cuts or other damage on the webbing is found, the entire belt assembly should be replaced.

CHILD RESTRAINTS

PRECAUTIONS ON CHILD RESTRAINTS



WARNING

- *Infants and small children should always be placed in an appropriate child restraint while riding in the vehicle. Failure to use a child restraint can result in serious in-*

jury or death.

- *Infants and small children should never be carried on your lap. It is not possible for even the strongest adult to resist the forces of a severe accident. The child could be crushed between the adult and parts of the vehicle. Also, do not put the same seat belt around both your child and yourself.*
- *Never install a rear facing child restraint in the front seat. An inflating supplemental front air bag could seriously injure or kill your child. A rear facing child restraint must only be used in the rear seat.*
- *INFINITI recommends that the child restraint be installed in the rear seat. According to accident*

SEATS, RESTRAINTS AND SUPPLEMENTAL AIR BAG SYSTEMS

statistics, children are safer when properly restrained in the rear seat than in the front seat.

- *An improperly installed child restraint could lead to serious injury or death in an accident.*

In general, child restraints are designed to be installed with the lap portion of a three-point type seat belt. In addition, this vehicle is equipped with a universal child restraint lower anchor system, referred to as the LATCH (Lower Anchors and Tether for Children) system. Some child restraints include two rigid or webbing-mounted attachments that can be connected to these lower anchors. For details, see “LATCH (Lower Anchors and Tether for Children) System” later in this section.

Child restraints for infants and children of various sizes are offered by several manufac-

turers. When selecting any child restraint, keep the following points in mind:

- choose only a restraint with a label certifying that it complies with Federal Motor Vehicle Safety Standard 213 or Canadian Motor Vehicle Safety Standard 213.
- check the child restraint in your vehicle to be sure it is compatible with the vehicle's seat and seat belt system.
- if the child restraint is compatible with your vehicle, place your child in the child restraint and check the various adjustments to be sure the child restraint is compatible with your child. Always follow all recommended procedures.

All US states and Canadian provinces require that infants and small children be restrained in approved child restraints at all times while the vehicle is being operated.



WARNING

- *Improper use of a child restraint can result in increased injuries for both the infant or child and other occupants in the vehicle.*
- *Follow all of the child restraint manufacturer's instructions for installation and use. When purchasing a child restraint, be sure to select one which will fit your child and vehicle. It may not be possible to properly install some types of child restraints in your vehicle.*
- *If the child restraint is not anchored properly, the risk of a*

SEATS, RESTRAINTS AND SUPPLEMENTAL AIR BAG SYSTEMS

child being injured in a collision or a sudden stop greatly increases.

- *Adjustable seatbacks should be positioned to fit the child restraint, but as upright as possible.*
- *After attaching the child restraint, test it before you place the child in it. Tilt it from side to side. Try to tug it forward and check to see if the belt holds the restraint in place. If the restraint is not secure, tighten the belt as necessary, or put the restraint in another seat and test it again.*
- *For a front facing child restraint, check to make sure the shoulder belt does not go in front of the child's face or neck. If it does, put*

the shoulder belt behind the child restraint. If you must install a front facing child restraint in the front seat, see instructions later in this section.

- *When your child restraint is not in use, store it in the trunk or keep it secured with a seat belt to prevent it from being thrown around in case of a sudden stop or accident.*



CAUTION

Remember that a child restraint left in a closed vehicle can become very hot. Check the seating surface and buckles before placing your child in the child restraint.

INSTALLATION ON REAR SEAT CENTER OR OUTBOARD POSITIONS

Front facing



WARNING

- *The three-point belt on your vehicle is equipped with a locking mode retractor which must be used when installing a child restraint.*
- *Failure to do so will result in the child restraint not being properly secured. It could tip over or otherwise be unsecured and cause injury to the child in a sudden stop or collision.*

When you install a child restraint in a rear outboard or center seat, follow these steps:

SEATS, RESTRAINTS AND SUPPLEMENTAL AIR BAG SYSTEMS

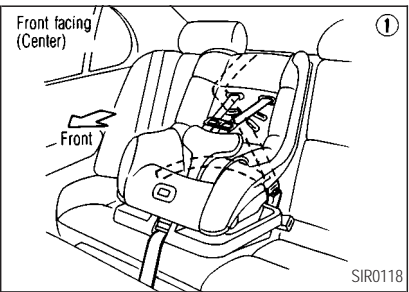
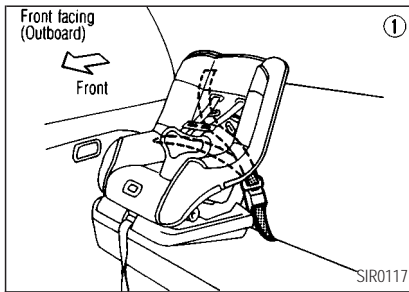

1. Position the child restraint on the seat. The direction of the child restraint depends on the type of the child restraint and the size of the child. Always follow the restraint manufacturer's instructions.

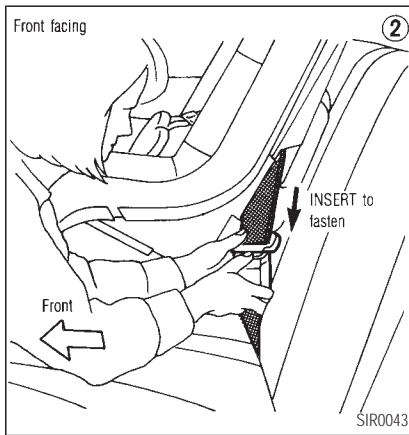

2. Route the seat belt tongue through the child restraint and insert it into the buckle until you hear and feel the latch engage. Be sure to follow the child restraint manufacturer's instructions for belt routing.

SEATS, RESTRAINTS AND SUPPLEMENTAL AIR BAG SYSTEMS

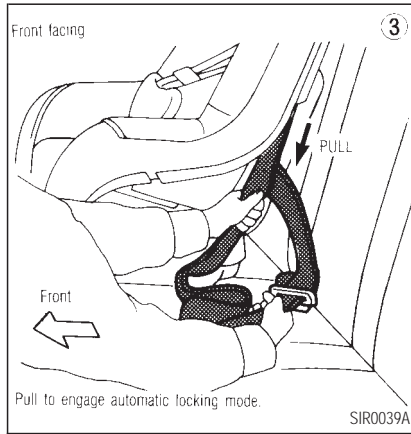

3. Pull on the shoulder belt until all of the belt is fully extended. At this time, the belt retractor is in the automatic locking mode (child restraint mode). It reverts back to emergency locking mode when the belt is fully retracted.

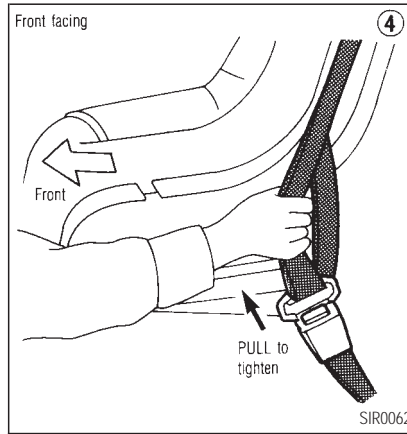

4. Allow the belt to retract. Pull up on the belt to remove any slack in the belt.

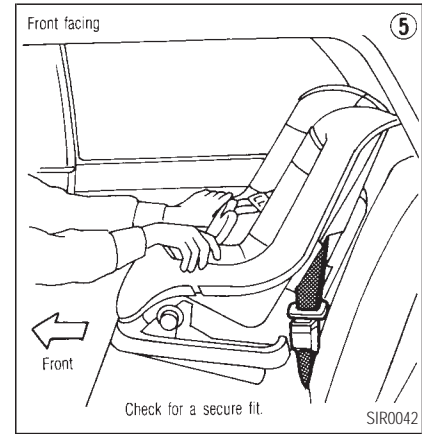

5. Before placing the child in the child restraint, use force to tilt the child restraint from side to side, and tug it forward to make sure that it is securely held in place.
6. Check that the retractor is in the automatic locking mode by trying to pull more belt out of the retractor. If you cannot pull any

SEATS, RESTRAINTS AND SUPPLEMENTAL AIR BAG SYSTEMS

more belt webbing out of the retractor, the belt is in the automatic locking mode.

7. Check to make sure that the child restraint is properly secured prior to each use. If the belt is not locked, repeat steps 3 through 6.

After the child restraint is removed and the seat belt is allowed to wind back into the retractor, the automatic locking mode (child restraint mode) is canceled; the seat belt only locks during a sudden stop or impact.

Rear facing



WARNING

- *The three-point belt on your vehicle is equipped with a locking mode retractor which must be used when installing a child restraint.*

- *Failure to do so will result in the child restraint not being properly secured. It could tip over or otherwise be unsecured and cause injury to the child in a sudden stop or collision.*

When you install a child restraint in a rear outboard or center seat, follow these steps:

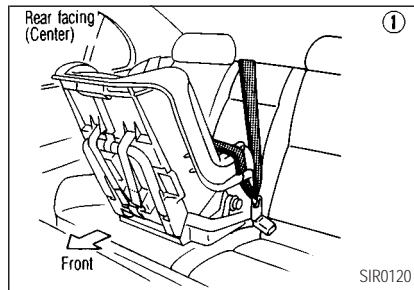
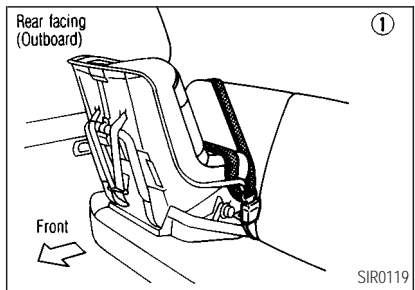

1. Position the child restraint on the seat. The direction of the child restraint depends on the type of the child restraint and the size of the child. Always follow the restraint manufacturer's instructions.

SEATS, RESTRAINTS AND SUPPLEMENTAL AIR BAG SYSTEMS

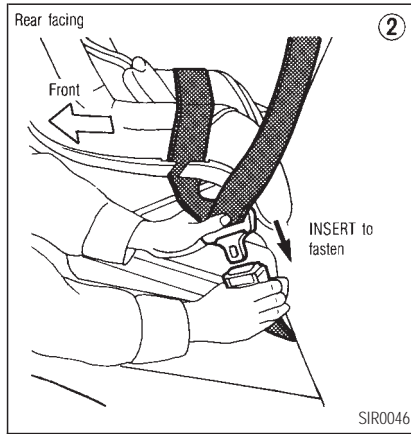

2. Route the seat belt tongue through the child restraint and insert it into the buckle until you hear and feel the latch engage. Be sure to follow the child restraint manufacturer's instructions for belt routing.

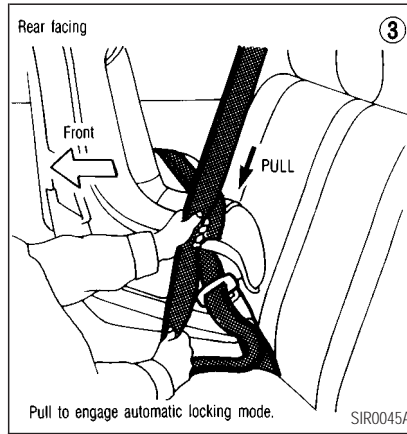

3. Pull on the shoulder belt until all of the belt is fully extended. At this time, the belt retractor is in the automatic locking mode (child restraint mode). It reverts back to emergency locking mode when the belt is fully retracted.

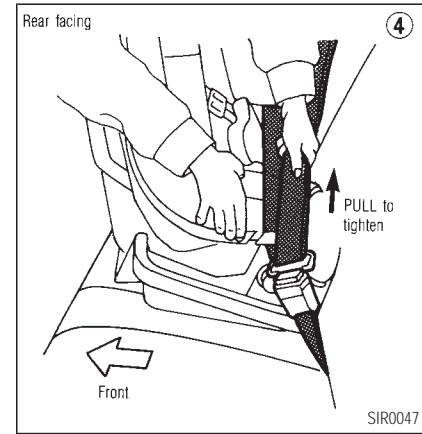

4. Allow the belt to retract. Pull up on the belt to remove any slack in the belt.

SEATS, RESTRAINTS AND SUPPLEMENTAL AIR BAG SYSTEMS

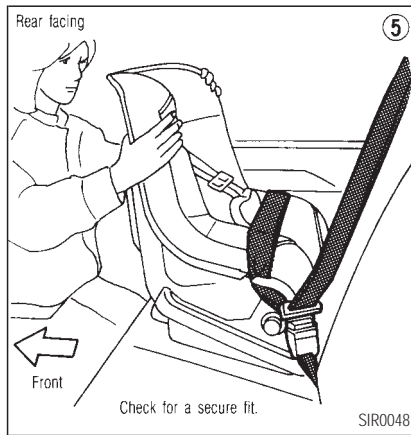

5. Before placing the child in the child restraint, use force to tilt the child restraint from side to side, and tug it forward to make sure that it is securely held in place.
6. Check that the retractor is in the automatic locking mode by trying to pull more belt out of the retractor. If you cannot pull any

more belt webbing out of the retractor, the belt is in the automatic locking mode.

7. Check to make sure that the child restraint is properly secured prior to each use. If the belt is not locked, repeat steps 3 through 6.

After the child restraint is removed and the seat belt is allowed to wind back into the retractor, the automatic locking mode (child restraint mode) is canceled; the seat belt only locks during a sudden stop or impact.

LATCH (LOWER ANCHOR AND TETHER FOR CHILDREN) SYSTEM

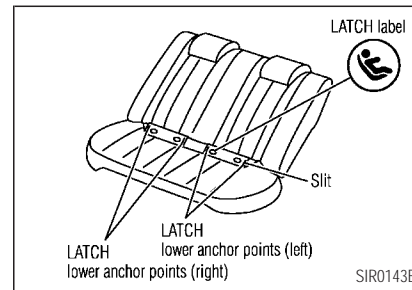

WARNING

- **Attach LATCH system compatible child restraints only at the locations shown. If a child restraint is not secured properly, your child**

SEATS, RESTRAINTS AND SUPPLEMENTAL AIR BAG SYSTEMS

could be seriously injured or killed in an accident.

- ***Do not secure a child restraint in the center rear seating position using the LATCH system anchors. The child restraint will not be secured properly.***
- ***The LATCH system anchors are designed to withstand only those loads imposed by correctly fitted child restraints. Under no circumstance are they to be used for adult seat belts or harnesses.***

Some child restraints include two rigid or webbing-mounted attachments that can be connected to two anchors located at certain seating positions in your vehicle. This system is known as the LATCH (Lower Anchors and Tether for Children) system. This system may also be referred to as the ISOFIX or ISOFIX

compatible system. With this system, you do not have to use a vehicle seat belt to secure the child restraint. Your vehicle is equipped with special anchor points that are used with LATCH system compatible child restraints. Check your child restraint for a label starting that it is compatible with the LATCH system. This information may also be in the child restraint owner's manual. If you have such a child restraint, refer to the illustration for the seating positions equipped with LATCH system anchors which can be used to secure the child restraint.

The LATCH system anchors are located at the rear of the seat cushion near the seatback. A label is attached to the seatback to help you locate the LATCH system anchors.

Some child restraints may also require the use of a top tether strap. See "Top tether strap child restraint" later in this section for installation instructions.

When installing, carefully read and follow the instructions in this manual and those supplied with the child restraint.

When you install a LATCH system compatible child restraint to the lower anchor attachments, follow these steps:



WARNING

Inspect the lower anchors by inserting your fingers into the lower anchor area and feeling to make sure there are no obstructions over the LATCH system anchors, such as seat belt webbing or seat cushion material. The child restraint will not be secured properly if the LATCH system anchors are obstructed.

1. To install the LATCH system compatible child restraint, insert the child restraint

SEATS, RESTRAINTS AND SUPPLEMENTAL AIR BAG SYSTEMS

LATCH system attachments into the anchor points on the seat. If the child restraint is equipped with a top tether, see “Top tether child restraint” later in this section for installation instructions.

2. After attaching the child restraint and before placing the child in it, use force to tilt the child restraint from side to side and tug it forward to make sure that the child restraint is securely held in place.
3. Check to make sure that the child restraint is properly secured prior to each use.

TOP TETHER STRAP CHILD RESTRAINT

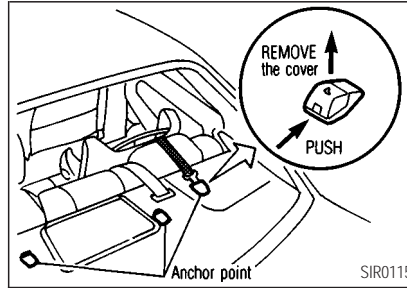

If your child restraint has a top tether strap, it must be secured to the provided anchor point. First, secure the child restraint with the rear seat belt.

Remove the anchor cover from the anchor point which is located directly behind the child seat.

Secure the top tether strap to the anchor bracket.

Tighten the strap according to the manufacturer's instructions to remove any slack.

Keep the removed cover in a secured place to prevent loss or damage.



WARNING

The child restraint anchor point is designed to withstand only those loads imposed by correctly fitted child restraints. Under no circumstance is it to be used for adult seat belts or harnesses.

Anchor point locations

Anchor points are located on the rear parcel shelf finisher.

If you have any questions when installing a top strap child restraint on the rear seat, consult your INFINITI retailer for details.

SEATS, RESTRAINTS AND SUPPLEMENTAL AIR BAG SYSTEMS

INSTALLATION ON FRONT PASSENGER SEAT

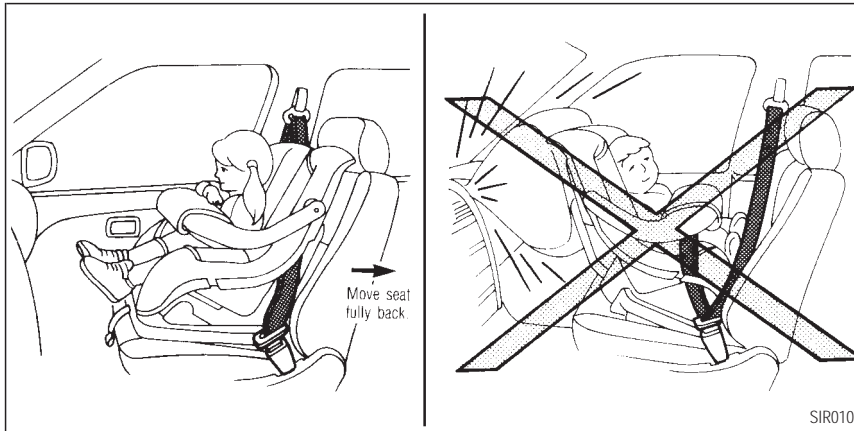

WARNING

- *Never install a rear facing child*

restraint in the front passenger seat. Supplemental front air bags inflate with great force. A rear facing child restraint could be struck

by the air bag in a crash and could seriously injure or kill your child.

- *INFINITI recommends that child restraints be installed in the rear seat. However, if you must install a front facing child restraint in the front passenger seat, move the passenger seat to the rearmost position.*
- *A child restraint with a top tether strap should not be used in the front passenger seat.*
- *The three-point belt in your vehicle is equipped with a locking mode retractor which must be used when installing a child restraint.*

SEATS, RESTRAINTS AND SUPPLEMENTAL AIR BAG SYSTEMS

- *Failure to use the retractor's locking mode will result in the child restraint not being properly secured. The child restraint could tip over or otherwise be unsecured and cause injury to the child in a sudden stop or collision.*

Front facing

If you must install a child restraint in the front seat, follow these steps:

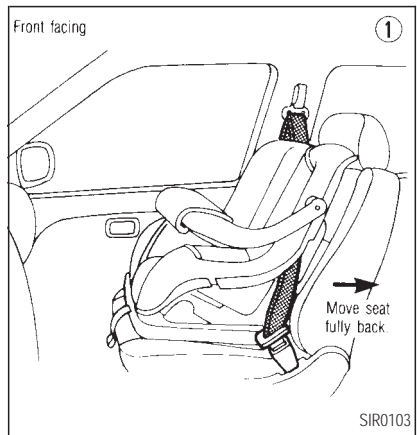

1. Position the child restraint on the front passenger seat. **It should be placed in a front facing direction only.** Move the seat to the rearmost position. Always follow

the child restraint manufacturer's instructions. **Child restraints for infants must be used in the rear facing direction and therefore must not be used in the front seat.**

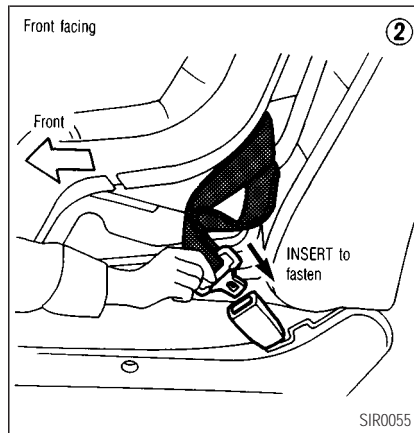

2. Route the seat belt tongue through the child restraint and insert it into the buckle

SEATS, RESTRAINTS AND SUPPLEMENTAL AIR BAG SYSTEMS

until you hear and feel the latch engage. Be sure to follow the child restraint manufacturer's instructions for belt routing.

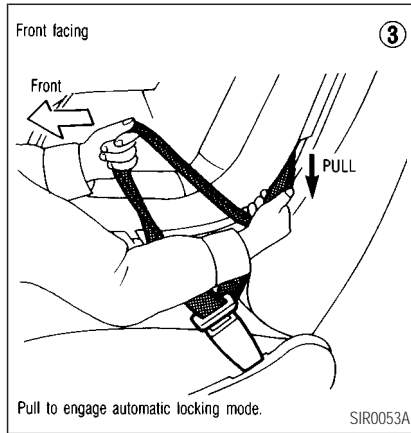

3. Pull on the shoulder belt until all of the belt is fully extended. At this time, the belt retractor is in the automatic locking mode (child restraint mode). It reverts back to

emergency locking mode when the belt is fully retracted.

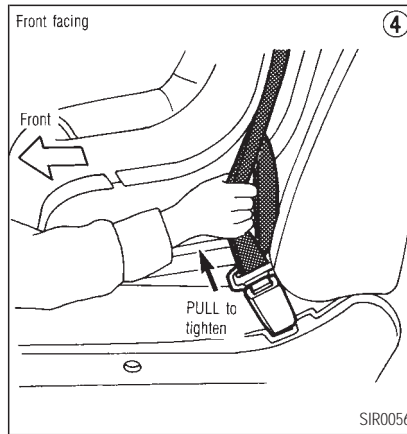

4. Allow the belt to retract. Pull up on the belt to remove any slack in the belt.



5. Before placing the child in the child restraint, use force to tilt the child restraint from side to side, and tug it forward to make sure that it is securely held in place.
6. Check that the retractor is in the automatic locking mode by trying to pull more belt out of the retractor. If you cannot pull any

SEATS, RESTRAINTS AND SUPPLEMENTAL AIR BAG SYSTEMS

more belt webbing out of the retractor, the belt is in the automatic locking mode.

7. Check to make sure that the child restraint is properly secured prior to each use. If the lap belt is not locked, repeat steps 3 through 6.

After the child restraint is removed and the seat belt is allowed to wind back into the retractor, the automatic locking mode (child restraint mode) is canceled; the seat belt only locks during a sudden stop or impact.

2 INSTRUMENTS AND CONTROLS

Instrument panel	2-2	Turn signal switch.....	2-20
Meters and gauges	2-3	Cornering light.....	2-21
Speedometer and odometer	2-4	Front fog light switch	2-21
Tachometer.....	2-4	Hazard warning flasher switch	2-21
Engine coolant temperature gauge	2-5	Horn.....	2-22
Fuel gauge.....	2-5	Heated seats (if so equipped)	2-22
Warning/indicator lights and audible		Heated steering wheel (if so equipped)	2-23
reminders.....	2-7	Traction control system (TCS) cancel	
Checking bulbs.....	2-7	switch (if so equipped)	2-24
Warning lights.....	2-8	Vehicle dynamic control off switch (if so	
Indicator lights.....	2-11	equipped)	2-24
Audible reminders.....	2-13	Power outlet	2-24
Security systems	2-13	Cigarette lighter and ashtray.....	2-25
Vehicle security systems.....	2-13	Sunglasses holder	2-26
Infiniti Vehicle Immobilizer System.....	2-15	Cup holder.....	2-26
Windshield wiper and washer switch.....	2-16	Glove box	2-27
Rear window and outside mirror (if so		Console box.....	2-28
equipped) defogger switch.....	2-17	Cargo net (if so equipped)	2-28
Headlight and turn signal switch.....	2-17	Windows.....	2-29
Xenon headlights.....	2-17	Power windows.....	2-29
Headlight switch.....	2-18	Sunroof (if so equipped)	2-31

Electric sunroof	2-31
Rear sun shade (if so equipped).....	2-33
Clock	2-34
Adjusting the time	2-34
Trip computer	2-35
Interior light	2-36
Ceiling.....	2-36
Personal light.....	2-37
Front	2-38
Vanity mirror lights.....	2-39
Trunk light	2-39
HomeLink® Universal Transceiver (if so equipped)	2-39

Programming HomeLink®	2-40
Programming HomeLink® for Canadian customers.....	2-42
Operating the HomeLink® Universal Transceiver	2-42
Programming trouble diagnosis.....	2-42
Clearing the programmed information	2-43
Reprogramming a single HomeLink® button	2-43
If your vehicle is stolen.....	2-43

INSTRUMENTS AND CONTROLS

INSTRUMENT PANEL

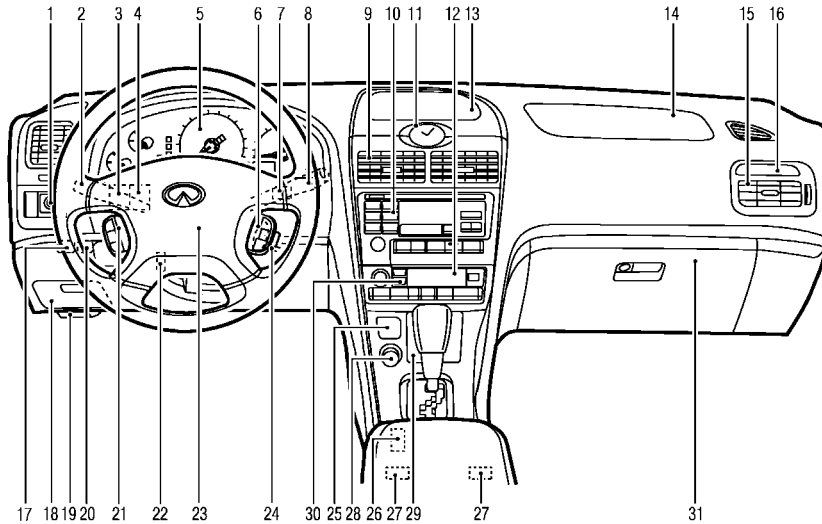

- 1 Outside mirror remote control (P.3-18)
- 2 Headlight and turn signal switch (P.2-17)/Front fog light switch (P.2-21)
- 3 Security indicator light (P.2-14)
- 4 Instrument brightness control switch (P.2-19)
- 5 Meters/gauges (P.2-3)
- 6 Cruise control main/set switch (P.5-12)
- 7 Traction control (TCS) or Vehicle dynamic control (VDC) OFF switch (if so equipped) (P.2-24)
- 8 Windshield wiper/washer switch (P.2-16)
- 9 Center ventilator (P.4-2)
- 10 Audio system (P.4-7) and navigation control*
- 11 Clock (P.2-35)
- 12 Automatic air conditioner (P.4-3)
- 13 Navigation system*
- 14 Front passenger supplemental air bag (P.1-7)
- 15 Side ventilator (P.4-2)
- 16 Cup holder (P.2-27)

SI10362

INSTRUMENTS AND CONTROLS

- 17 Automatic drive position system cancel switch (P.3-21)
- 18 Fuse box cover (P.8-21)
- 19 Hood release handle (P.3-10)
- 20 Heated steering switch (P.2-24)
- 21 Steering switch for audio control (P.4-27) and trip computer (P.2-35)
- 22 Tilting steering wheel lock lever (P.3-15)
- 23 Driver supplemental air bag (P.1-7)
- 24 Ignition switch/steering lock (P.5-5)
- 25 Hazard warning flasher switch (P.2-22)
- 26 Rear sun shade control switch (P.2-34)
- 27 Heated seat switch (if so equipped) (P.2-33)
- 28 Cigarette lighter (P.2-25)
- 29 Ashtray (P.2-25)
- 30 Rear window and outside door mirror defogger switch (P.2-17)
- 31 Glove box (P.2-28)

See the page indicated in parentheses for operating details.

*: Refer to the separate Navigation System Owner's Manual. (if so equipped)

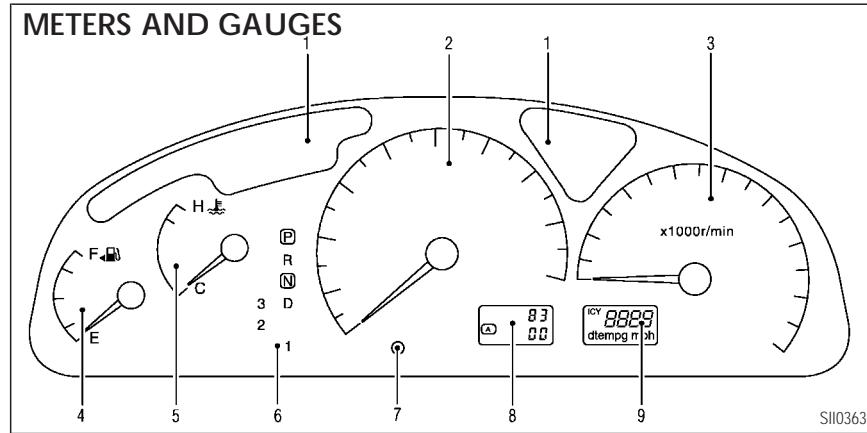

- 1 Warning/Indicator lights
- 2 Speedometer
- 3 Tachometer
- 4 Fuel gauge
- 5 Engine coolant temperature gauge
- 6 A/T indicator
- 7 Reset knob for trip odometer
- 8 Odometer (Total/twin trip)
- 9 Display for trip computer

INSTRUMENTS AND CONTROLS

SPEEDOMETER AND ODOMETER

Speedometer

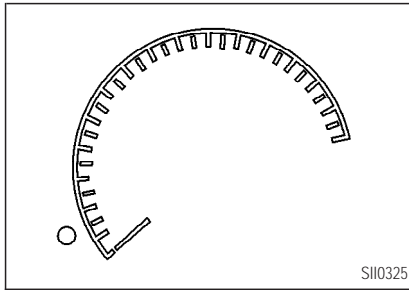

The speedometer indicates vehicle speed.

Odometer/Twin trip odometer

The odometer/twin trip odometer are displayed when the ignition key is in the ON position.

The odometer records the total distance the vehicle has been driven.

The twin trip odometer records the distance of individual trips.

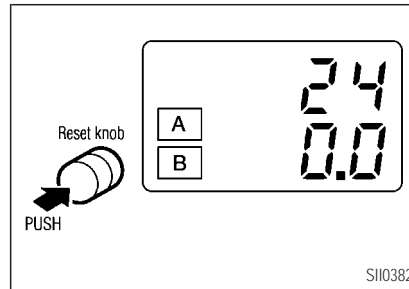

Changing the display:

Pushing the reset knob changes the display as follows:

TRIP A → TRIP B → TRIP A

Resetting the trip odometer:

Pushing the reset knob for more than 1 second resets the trip odometer to zero.

TACHOMETER

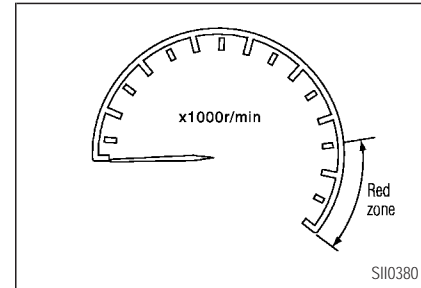

The tachometer indicates engine speed in revolutions per minute (r/min).



When engine speed approaches the red zone, shift to a higher gear. Operating the engine in the red zone may cause serious engine damage.

INSTRUMENTS AND CONTROLS

ENGINE COOLANT TEMPERATURE GAUGE

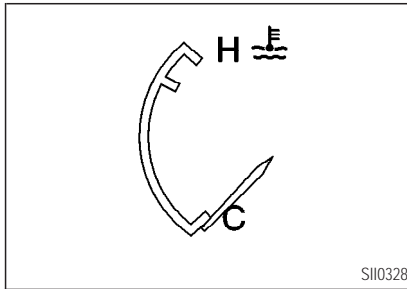

The gauge indicates the engine coolant temperature.

The engine coolant temperature will vary with the outside air temperature and driving conditions.



CAUTION

If the gauge indicates engine coolant temperature over the normal range, stop the vehicle as soon as safely possible. If the engine is overheated, continued operation of the vehicle may seriously damage the engine. See “If your vehicle overheats” in the “6. In case of emergency” section for immediate action required.

FUEL GAUGE

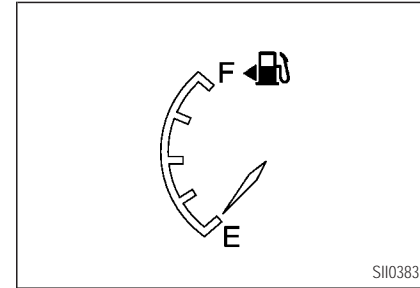

The gauge indicates the approximate fuel level in the tank.

The gauge may move slightly during braking, turning, acceleration, or going up or down hill.

Refill the fuel tank before the gauge registers Empty.

The low fuel warning light comes on when the fuel tank is getting low. Refuel as soon as it is convenient, preferably



INSTRUMENTS AND CONTROLS

before the gauge reaches E. There will be a small reserve of fuel in the tank when the fuel gauge needle reaches E.

The  indicates that the fuel filler lid is located on the driver's side of the vehicle.























CAUTION

- *If the vehicle runs out of fuel, the  malfunction indicator lamp (MIL) may come on. Refuel as soon as possible. After a few driving trips, the  lamp should turn off. If the lamp remains on after a few driving trips, have the vehicle inspected by an authorized INFINITI retailer.*
- *For additional information, see the “Malfunction indicator lamp (MIL)” later in this section.*

INSTRUMENTS AND CONTROLS

WARNING/INDICATOR LIGHTS AND AUDIBLE REMINDERS

 ABS	or 	Anti-lock brake warning light		Low washer fluid warning light		Malfunction indicator lamp (MIL)
 A/T CHECK		A/T check warning light (A/T models)		Seat belt warning light	 SLIP	Slip indicator light (if so equipped)
 BRAKE	or 	Brake warning light		Supplemental air bag warning light	 TCS OFF	Traction control system off indicator light (if so equipped)
		Charge warning light		Trunk lid open warning light		Turn signal/hazard indicator light
		Door open warning light	 CRUISE	Cruise main switch indicator light	 VDC OFF	Vehicle dynamic control off indicator light (if so equipped)
		Engine oil pressure warning light	 SET	Cruise set indicator light		
		Low fuel warning light		High beam indicator light (Blue)		

CHECKING BULBS

Apply the parking brake and turn the ignition key to ON without starting the engine. The following lights will come on:



The following lights come on briefly and then go off:



If any light fails to come on, it may indicate a burned-out bulb or an open circuit in the

electrical system. Have the system repaired promptly.

INSTRUMENTS AND CONTROLS

WARNING LIGHTS

 or  **Anti-lock brake warning light**

After turning the ignition key to the ON position, the anti-lock brake warning light will illuminate. The anti-lock brake warning light will turn off after about 2 seconds if the system is operational.

If the light comes on while the engine is running, it may indicate the anti-lock brake system is not functioning properly. Have the system checked by your INFINITI retailer.

If an abnormality occurs in the system, the anti-lock function will cease but the ordinary brakes will continue to operate normally.

If the light comes on while you are driving, contact your INFINITI retailer for repair.

 **A/T check warning light (A/T models)**

When the ignition switch is turned ON, the light comes on for 2 seconds. If the light blinks for approximately 8 seconds, it may indicate the automatic transmission system is not functioning properly. Have your INFINITI retailer check and repair the transmission.

 or  **Brake warning light**

This light functions for both the parking brake and the foot brake systems.

Parking brake indicator:

When the ignition key is in the ON position, the light comes on when the parking brake is applied.

Low brake fluid warning light:

The light warns of a low brake fluid level. If the light comes on while the engine is running with the parking brake not applied, stop the

vehicle and perform the following:

1. Check the brake fluid level. Add brake fluid as necessary. See “Brake and clutch fluid” in the “8. Do-it-yourself” section.



WARNING

- ***Your brake system may not be working properly if the warning light is on. Driving could be dangerous. If you judge it to be safe, drive carefully to the nearest service station for repairs. Otherwise, have your vehicle towed because driving it could be dangerous.***
- ***Pressing the brake pedal with the engine stopped and/or low brake fluid level may increase your stopping distance and braking***

INSTRUMENTS AND CONTROLS

will require greater pedal effort as well as greater pedal travel.

- *If the brake fluid level is below the MIN mark on the brake fluid reservoir, do not drive until the brake system has been checked at an INFINITI retailer.*

2. If the brake fluid level is correct, have the warning system checked by your INFINITI retailer.

Charge warning light

If the light comes on while the engine is running, it may indicate that the charging system is not functioning properly. Turn the engine off and check the alternator belt. If the belt is loose, broken, missing or if the light remains on, see your INFINITI retailer immediately.



CAUTION

Do not continue driving if the belt is loose, broken or missing.



Door open warning light

This light comes on when any of the doors are not closed securely while the ignition key is ON.



Engine oil pressure warning light

This light warns of low engine oil pressure. If the light flickers or comes on during normal driving, pull off the road in a safe area, stop the engine **immediately** and call an INFINITI retailer or other authorized repair shop.

The oil pressure warning light is not designed to indicate a low oil level. Use the dipstick to check the oil level. See "Engine

oil" in the "8. Do-it-yourself" section.



CAUTION

Running the engine with the oil pressure warning light on could cause serious damage to the engine almost immediately. Turn off the engine as soon as it is safe to do so.



Low fuel warning light

This light comes on when the fuel in the tank is getting low. Refuel as soon as it is convenient, preferably before the fuel gauge reaches E.

There will be a small reserve of fuel remaining in the tank when the fuel gauge needle reaches E.

INSTRUMENTS AND CONTROLS



Low washer fluid warning light

This light comes on when the washer tank fluid is at a low level. Add washer fluid as necessary. See “Window washer fluid” in the “8. Do-it-yourself” section.



Seat belt warning light and chime

The light and chime remind you to fasten seat belts. The light illuminates whenever the ignition key is turned to ON, and will remain illuminated until the driver's seat belt is fastened. At the same time, the chime will sound for about 6 seconds unless the driver's seat belt is securely fastened.

See “Seat belts” in the “1. Seats, restraints and supplemental air bag systems” section for precautions on seat belt usage.



Supplemental air bag warning light

After turning the ignition key to the ON position, the supplemental air bag warning light will illuminate. The supplemental air bag warning light will turn off after about 7 seconds if the supplemental front air bag system, supplemental side air bag system and/or pre-tensioner seat belt are operational.

If any of the following conditions occur, the supplemental front air bag, supplemental side air bag and pre-tensioner seat belt need servicing and your vehicle must be taken to your nearest authorized INFINITI retailer.

- The supplemental air bag warning light does not come on and remain on for 7 seconds and then go off as described above.
- The supplemental air bag warning light flashes intermittently or remains on (after 7 seconds).

- The supplemental air bag warning light does not come on at all.

Unless checked and repaired, the supplemental restraint system and/or the pre-tensioner seat belt may not function properly. For additional information, see “Supplemental restraint system” in the “1. Seats, restraints and supplemental air bag systems” section.



WARNING

If the supplemental air bag warning light is on, it could mean that the supplemental air bag system, supplemental side air bag system and/or pre-tensioner seat belt will not operate in an accident.



Trunk lid open warning light

This light comes on when the trunk lid is not

INSTRUMENTS AND CONTROLS

closed securely while the ignition key is ON.

INDICATOR LIGHTS



Cruise main switch indicator light

The light comes on when the main switch is pushed. The light goes out when the main switch is pushed again. When the cruise main switch indicator light comes on, the cruise control system is operational.



Cruise set indicator light

The light comes on while the vehicle speed is controlled by the cruise control system. If the light flickers while the engine is running, it may indicate the cruise control system is not functioning properly. Have the system checked by your INFINITI retailer.



High beam indicator light (Blue)

This light comes on when the headlight high

beam is on and goes out when the low beam is selected.



Malfunction indicator lamp (MIL)



If the malfunction indicator lamp comes on steady or blinks while the engine is running, it may indicate a potential emission control malfunction.

The malfunction indicator lamp may also come on steady if the fuel filler cap is loose or missing, or if the vehicle runs out of fuel. Check to make sure the fuel filler cap is installed and closed tightly, and that the vehicle has at least three gallons (14 liters) of fuel in the fuel tank.

After a few driving trips, the  lamp should turn off if no other potential emission control system malfunction exists.

Operation

The malfunction indicator lamp will come on in one of two ways:

- Malfunction indicator lamp on steady — An emission control system malfunction has been detected. Check the fuel filler cap. If the fuel filler cap is loose or missing, tighten or install the cap and continue to drive the vehicle. The  lamp should turn off after a few driving trips. If the  lamp does not turn off after a few driving trips, have the vehicle inspected by an authorized INFINITI retailer. You do not need to have your vehicle towed to the retailer.
- Malfunction indicator lamp blinking — An engine misfire has been detected which may damage the emission control system. To reduce or avoid emission control system damage:

INSTRUMENTS AND CONTROLS

- a) Do not drive at speeds above 45 MPH (72 km/h).
- b) Avoid hard acceleration or deceleration.
- c) Avoid steep uphill grades.
- d) If possible, reduce the amount of cargo being hauled or towed.

The malfunction indicator lamp may stop blinking and come on steady.

Have the vehicle inspected by an authorized INFINITI retailer. You do not need to have your vehicle towed to the retailer.



CAUTION

Continued vehicle operation without having the emission control system checked and repaired as necessary could lead to poor driveability, reduced fuel economy, and possible

damage to the emission control system.

SLIP

Slip indicator light (if so equipped)

This indicator will blink when the VDC system or the traction control system is operating, thus alerting the driver to the fact that the road surface is slippery and the vehicle is nearing its traction limits.

TCS
OFF

Traction control system off indicator light (if so equipped)

After turning the ignition key to the ON position, the light will illuminate. The light will turn off after about 2 seconds if the system is operational.

If the light stays on or comes on when you are driving, there may be a problem with your traction control system and it may not operate

properly. Have the system checked by your INFINITI retailer.

The traction control system off indicator light may come on for the following reasons.

- a) If the system is turned off by pressing the button on the instrument panel, the indicator light will come on and stay on. To turn the system back on, press the button again. The indicator light should go off.
- b) If engine speed is above 4,000 rpm in a selected gear. Use D range on low friction road surfaces.

If the traction control system off indicator light comes on and stays on for an extended period of time when the system is turned on, have your vehicle checked by your INFINITI retailer.

INSTRUMENTS AND CONTROLS

VDC
OFF

Vehicle dynamic control off indicator light (if so equipped)

The light comes on when the vehicle dynamic control off switch is pushed to OFF. This indicates the vehicle dynamic control system and the traction control system are not operating.

Push the vehicle dynamic control off switch again or restart the engine and the system will operate normally. See “Vehicle dynamic control” in the “5. Starting and driving” section.

While the vehicle dynamic control system is operating, you may feel slight vibration or hear the system working when starting the vehicle or accelerating, but this is normal.



Turn signal/hazard indicator lights

The light flashes when the turn signal switch lever or hazard switch is turned on.

AUDIBLE REMINDERS

Key reminder chime

The chime will sound if the driver's side door is opened while the key is left in the ignition switch (ignition switch is turned off). Remove the key and take it with you when leaving the vehicle.

Light reminder chime

The headlights reminder chime will sound when the driver's door is opened and the light switch is on, unless the ignition key is in the ON position.

Make sure to turn the light switch off when you leave the vehicle.

Seat belt warning chime

The chime will sound for about 6 seconds unless the driver's seat belt is securely fastened.

Brake pad wear warning

The disc brake pads have audible wear warnings. When a brake pad requires replacement, it will make a high pitched scraping sound when the vehicle is in motion whether or not the brake pedal is depressed. Have the brakes checked as soon as possible if the warning sound is heard.

SECURITY SYSTEMS

Your vehicle has two types of security systems, as follows:

- Vehicle Security System
- Infiniti Vehicle Immobilizer System

The security condition will be shown by the security indicator light.

VEHICLE SECURITY SYSTEM

The vehicle security system provides visual and audio alarm signals if parts of the vehicle are disturbed.

INSTRUMENTS AND CONTROLS

Security indicator light

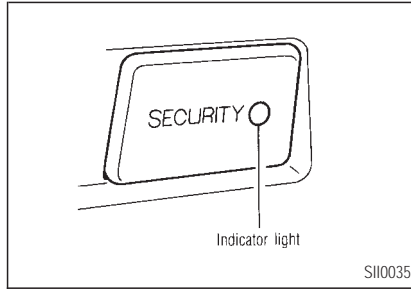

How to activate the vehicle security system

1. Close all windows.

The system can be activated even if the windows are open.

2. Remove the key from the ignition switch.
3. Close and lock all doors, hood and trunk lid. Lock all doors by pressing the LOCK button on the keyfob or with the key. When

using the keyfob, the hazard indicators flash twice to indicate all doors are locked.

4. Confirm that the SECURITY indicator light comes on. The SECURITY light glows for about 30 seconds and then blinks. The system is now activated. If, during this 30 second time period, the door is unlocked by the key or the keyfob, or the ignition key is turned to ACC or ON, the system will not activate.

- Even when the driver and/or passengers are in the vehicle, the system will activate with all doors, hood and trunk lid locked and ignition key off.

Vehicle security system operation

The security system will give the following alarm:

- the headlights blink and the horn sounds intermittently.

- the alarm automatically turns off after approximately 1 minute. However, the alarm reactivates if the vehicle is tampered with again. The alarm can be shut off by unlocking a door or trunk lid with the key, or by pressing the unlock button on the keyfob.

The alarm is activated by:

- Opening the door without using the key or keyfob.
- Opening the hood.

INSTRUMENTS AND CONTROLS

How to stop alarm

The alarm will stop only by unlocking a door or trunk lid with the key, or by pressing the UNLOCK button on the keyfob. The alarm will not stop if the ignition switch is turned to ACC or ON.

If the system does not operate as described above, have it checked by your INFINITI retailer.

INFINITI VEHICLE IMMOBILIZER SYSTEM

The Infiniti Vehicle Immobilizer System will not allow the engine to start without the use of the registered Infiniti Vehicle Immobilizer System key.

If the engine fails to start using the registered Infiniti Vehicle Immobilizer System key (for example, when interference is caused by another Infiniti Vehicle Immobilizer System key, an automated toll road device or automated payment device on the key ring), restart

the engine using the following procedures:

1. Leave the ignition switch in the ON position for approximately 5 seconds.
2. Turn the ignition switch to the OFF or LOCK position and wait approximately 10 seconds.
3. Repeat step 1 and 2 again.
4. Restart the engine while holding the device (which may have caused the interference) separate from the registered Infiniti Vehicle Immobilizer System key.

If this procedure allows the engine to start, INFINITI recommends placing the registered Infiniti Vehicle Immobilizer System key on a separate key ring to avoid interference from other devices.

Statement related to section 15 of FCC rules for Infiniti Vehicle Immobilizer System (CONT ASSY-IMMOBILIZER, ANT ASSY-IMMOBILIZER)

This device complies with part 15 of the FCC Rules and RSS-210 of Industry of Canada. Operation is subject to the following two conditions;

(1) This device may not cause harmful interference, and (2) this device must accept any interference received, including interference that may cause undesired operation of the device.

Changes or modifications not expressly approved by the manufacturer for compliance could void the user's authority to operate the equipment.

INSTRUMENTS AND CONTROLS

Security indicator light

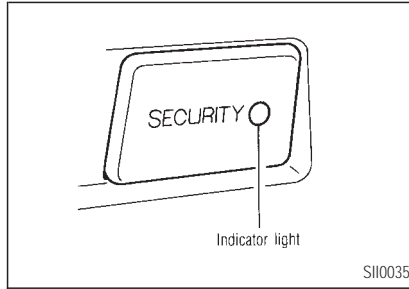

This light blinks whenever the ignition switch is in the LOCK, OFF or ACC position. This function indicates the security systems equipped on the vehicle are operational.

If Infiniti Vehicle Immobilizer System is malfunctioning, this light will remain on while the ignition key is in the ON position.

If the light still remains on and/or the engine will not start, see your INFINITI retailer for Infiniti Vehicle Immobilizer

System service as soon as possible. Please bring all Infiniti Vehicle Immobilizer System keys that you have when visiting your INFINITI retailer for service.

WINDSHIELD WIPER AND WASHER SWITCH

The windshield wiper and washer operates when the ignition key is in the ON position.

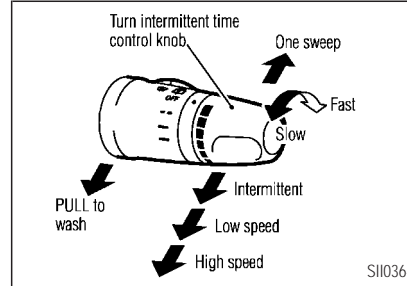

Push the lever down to operate the wiper.

Intermittent operation can be adjusted from 2 to 13 seconds by turning the knob.

Pull the lever toward you to operate the washer. The wiper will also operate several times.

WARNING

In freezing temperatures the washer solution may freeze on the windshield and obscure your vision which may lead to an accident. Warm the windshield with the defroster before you wash the windshield.

CAUTION

The following could damage the washer system:

- *Do not operate the washer continuously for more than 30 seconds.*
- *Do not operate the washer if the reservoir tank is empty.*

INSTRUMENTS AND CONTROLS

REAR WINDOW AND OUT-SIDE MIRROR (if so equipped) DEFOGGER SWITCH

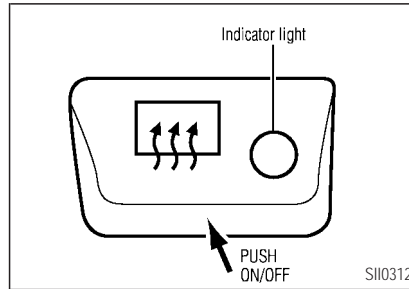

To defog/defrost the rear window glass and outside mirrors (if so equipped), start the engine and push the switch on. The indicator light will come on. Push the switch again to turn the defogger off.

It will automatically turn off in approximately 15 minutes.

CAUTION

When cleaning the inner side of the rear window, be careful not to scratch or damage the rear window defogger.

HEADLIGHT AND TURN SIGNAL SWITCH XENON HEADLIGHTS

WARNING

HIGH VOLTAGE

- *When xenon headlights are on, they produce a high voltage. To prevent an electric shock, never attempt to modify or disas-*

semble. Always have your xenon headlights replaced at an authorized INFINITI retailer.

- *Xenon headlights provide considerably more light than conventional headlights. If they are not correctly aimed, they might temporarily blind an oncoming driver or the driver ahead of you and cause a serious accident. If headlights are not aimed correctly, immediately take your vehicle to an authorized INFINITI retailer and have the headlights adjusted correctly.*

When the xenon headlight is initially turned on, its brightness or color varies slightly. However, the color and brightness will soon stabilize.

- **The life of xenon headlights will be**

INSTRUMENTS AND CONTROLS

shortened by frequent on-off operation. It is generally desirable not to turn off the headlights for short intervals (for example, when the vehicle stops at a traffic signal). Even when the daytime running lights are active (Canada only), the xenon headlights do not turn on. This way the life of the xenon headlights is not reduced.

- If the xenon headlight bulb is close to burning out, the brightness will drastically decrease, the light will start blinking, or the color of the light will become reddish. If one or more of the above signs appear, contact an INFINITI retailer.

HEADLIGHT SWITCH

Lighting

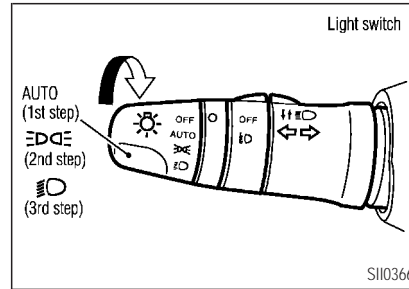

Turn the switch to the AUTO position:

When the ignition key is in the ON position, the tail light, headlight, instrument light and other lights turn on automatically, depending on the brightness of the surroundings. The headlight will automatically turn off 5 minutes after the ignition switch has been turned to the OFF position and the driver's or front passenger's door is opened. The headlight will also

automatically turn off 45 seconds after a front door is opened and closed.

When the light switch is turned to the  position, the headlight low or high beam will turn off.

Turn the switch to the  position:

The front parking, side marker, tail, license plate and instrument lights will come on.

Turn the switch to the  position:

Headlights will come on and all the other lights remain on.

INSTRUMENTS AND CONTROLS

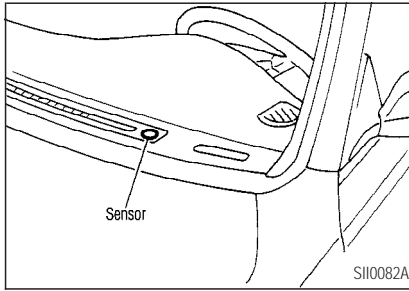

Be sure not to put anything on top of the photo sensor located on the top left-hand side of the instrument panel. The photo sensor controls the autolight; if it is covered, the photo sensor reacts as if it is dark and the headlights will illuminate.

Battery saver system

- When the headlight switch is in the $\equiv \text{D} \equiv$ or $\equiv \text{O}$ position while the ignition switch is in the ON position, the lights (including the front fog light) will auto-

matically turn off 5 minutes after the ignition switch has been turned to the OFF position.

- When the headlight switch remains in the $\equiv \text{D} \equiv$ or $\equiv \text{O}$ position after the lights automatically turn off, the lights will turn on when the headlight switch is turned to the OFF position, and turn to the $\equiv \text{D} \equiv$ or $\equiv \text{O}$ position.



CAUTION

- **Be sure to turn the light switch to the OFF position when you leave the vehicle for extended periods of time, otherwise the battery will go dead.**
- **Never leave the light switch on when the engine is not running for extended periods of time and if**

the headlight is turned off automatically.

Instrument brightness control

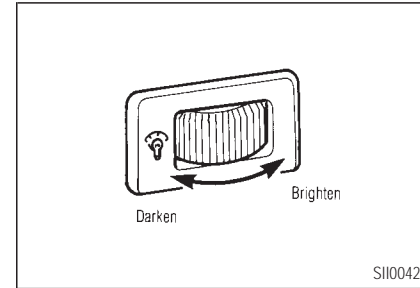

The instrument brightness control operates when the light switch is in the AUTO (ignition key is in the ON position), $\equiv \text{D} \equiv$ or $\equiv \text{O}$ position.

Turn the control to adjust the brightness of instrument panel lights (except clock) and power window switch lights.

INSTRUMENTS AND CONTROLS

When the control is turned to the right until a click sound is heard, the light intensity will be at maximum. When the control is turned to the left until a click sound is heard, the light will be turned off.

Headlight beam select

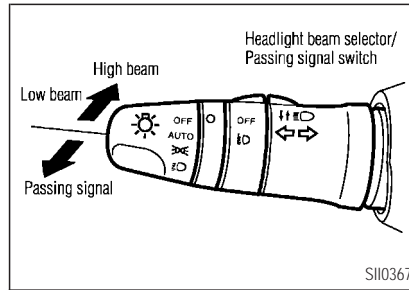



To select the high beam, push the lever forward. Pull it back to select the low beam.

Passing signal

Pulling the lever toward you will turn on the headlight high beam.

Daytime running light system (Canada only)

The headlights automatically illuminate at a reduced intensity when the engine is started with the parking brake released. The daytime running lights operate with the headlight switch in the OFF position or in the  position. Turn the headlight switch to the  position for full illumination when driving at night.

If the parking brake is applied before the engine is started, the daytime running lights do not illuminate. The daytime running lights illuminate once the parking brake is released. The daytime running lights will remain on until the ignition switch is turned off.



WARNING

When the daytime running light sys-

tem is active, tail lights on your vehicle are not on. It is necessary at dusk to turn on your headlights. Failure to do so could cause an accident injuring yourself and others.

TURN SIGNAL SWITCH

Turn signal

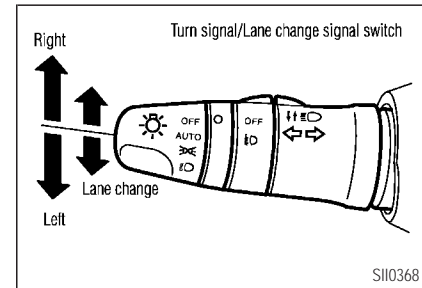

Move the lever up or down to signal the turning direction. When the turn is completed,

INSTRUMENTS AND CONTROLS

the turn signals cancel automatically.

Lane change signal

To indicate a lane change, move the lever up or down to the point where lights begin flashing.

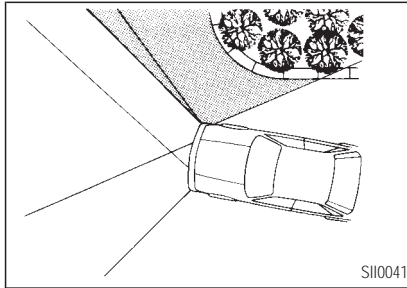

CORNERING LIGHT

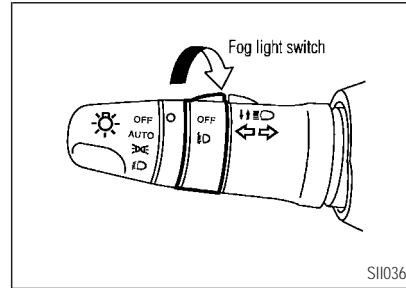

The cornering light provides additional illumination toward the turning direction. The light will come on when the turn signal lever is moved to the right or left with the headlights on.

FRONT FOG LIGHT SWITCH



To turn the fog lights on, turn the headlight switch to the  position, then turn the switch to the  position. To turn them off, turn the switch to the OFF position.

The headlights must be on for the fog lights to operate.

HAZARD WARNING FLASHER SWITCH

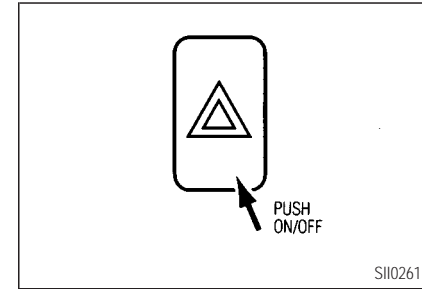

Push the switch on to warn other drivers when you must stop or park under emergency conditions. All turn signal lights will flash.

Some state laws may prohibit the use of the hazard warning flasher switch while driving.

INSTRUMENTS AND CONTROLS



WARNING

- *If stopping for an emergency, be sure to move the vehicle well off the road.*
- *Do not use the switch while moving on the highway unless unusual circumstances force you to drive so slowly that your vehicle might become a hazard to other traffic.*
- *Turn signals do not work when the switch is operating.*

The flasher can be actuated with the ignition switch either off or on.

HORN

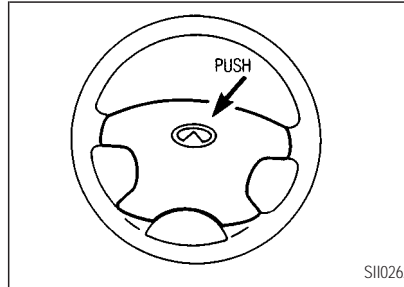

To sound the horn, push the center pad area of the steering wheel.



WARNING

Do not disassemble the horn. Doing so could affect proper operation of the supplemental front air bag system. Tampering with the supplemental front air bag system may result in

serious personal injury.

HEATED SEATS (if so equipped)

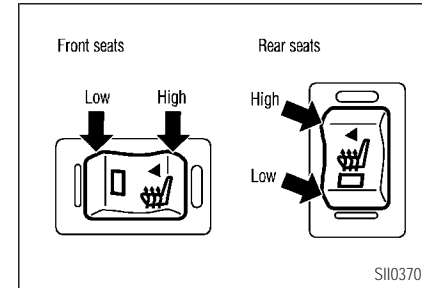

The front seats or rear seats are warmed by built-in heaters. The switches are located on the center console and on the inside of the rear door.

1. Start the engine.
2. Push the low or high position of the switch, as desired, depending on the tem-

perature. The indicator light in the switch will illuminate.

The heater is controlled by a thermostat, automatically turning the heater on and off. The indicator light will remain on as long as the switch is on.

3. When the seat is warmed or before you leave the vehicle, be sure to turn the switch to the off position (center).



CAUTION

- **Do not use the seat heater for extended periods or when no one is using the seat.**
- **Do not put anything on the seat which insulates heat, such as a blanket, cushion, seat cover, etc. Otherwise, the seat may become overheated.**

- **Do not place anything hard or heavy on the seat or pierce it with a pin or similar object. This may result in damage to the heater.**
- **Any liquid spilled on the heated seat should be removed immediately with a dry cloth.**
- **When cleaning the seat, never use benzine, thinner, or any similar materials.**
- **If any abnormalities are found or the heated seat does not operate, turn the switch off and have the system checked by your INFINITI retailer.**
- **The battery could run down if the seat heater is operated while the engine is not running.**

INSTRUMENTS AND CONTROLS

HEATED STEERING WHEEL (if so equipped)

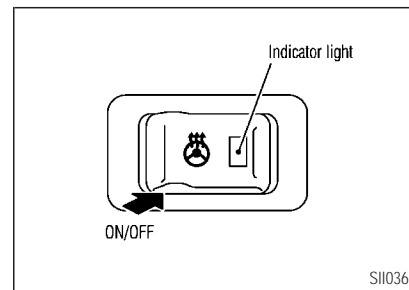

Push the heated steering switch to warm the steering wheel after the engine starts.

The indicator lights will come on.

Push the switch again to turn the heated steering off.

It will automatically turn off in approximately 30 minutes.

INSTRUMENTS AND CONTROLS

TRACTION CONTROL SYSTEM (TCS) CANCEL SWITCH (if so equipped)

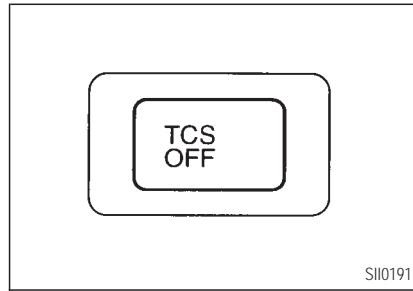

To cancel the Traction Control System (TCS), push the TCS OFF switch. The indicator **TCS OFF** will come on. Push it again or restart the engine to turn the system back on.

See "Traction control system" in the "5. Starting and driving" section.

VEHICLE DYNAMIC CONTROL OFF SWITCH (if so equipped)

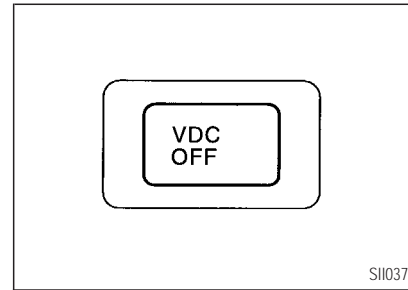

To cancel the Vehicle Dynamic Control System (VDC), push the "VDC OFF" switch to turn off the system. The **VDC OFF** indicator will come on.

Push the "VDC OFF" switch again or restart the engine and the system will operate normally. See "Vehicle dynamic control" in the "5. Starting and driving" section.

POWER OUTLET

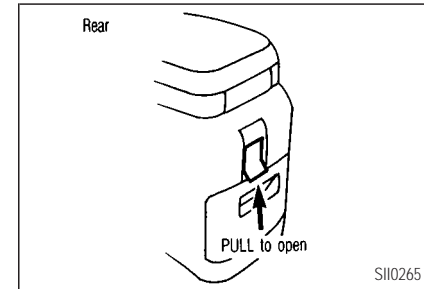

The power outlet is for powering electrical accessories such as cellular telephones.



CAUTION

- Use caution as the outlet and plug may be hot during or immediately after use.
- This power outlet is not designed

INSTRUMENTS AND CONTROLS

for use with a cigarette lighter unit.

- Do not use with accessories that exceed a 12 volt, 120W (10A) power draw. Do not use double adapters or more than one electrical accessory.
- Use this power outlet with the engine running. (If the engine is stopped, this could result in a discharged battery.)
- Avoid using when the air conditioner, headlights or rear window defogger is on.
- Before inserting or disconnecting a plug, be sure to turn off the power switch of electrical accessory being used or the ACC power of the vehicle.

- Push the plug in as far as it will go. If good contact is not made, the plug may overheat or the internal temperature fuse may blow.
- When not in use, be sure to close the cap. Do not allow water to contact the socket.

CIGARETTE LIGHTER AND ASHTRAY

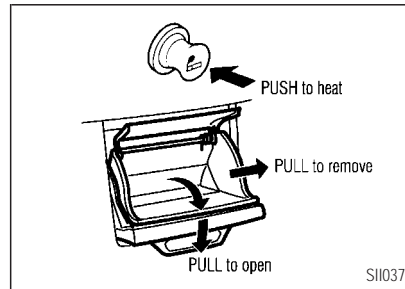

The cigarette lighter operates when the ignition switch is in the ACC or ON position.

Push the lighter in all the way. When the lighter is heated, it will spring out.

Return the lighter to its original position after use.



WARNING

The cigarette lighter should not be used while driving so full attention may be given to vehicle operation.



CAUTION

The cigarette lighter socket is a power source for the cigarette lighter element only. The use of the cigarette lighter socket as a power source

INSTRUMENTS AND CONTROLS

for any other accessory is not recommended.

SUNGLASSES HOLDER

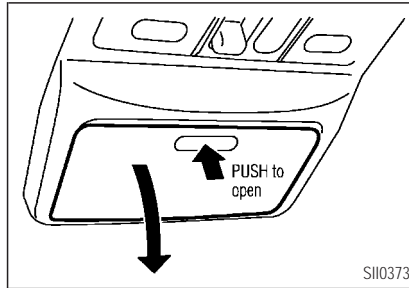

The sunglasses holder can be opened by pushing the lid.

! WARNING

The sunglasses holder should not be

used while driving so full attention may be given to vehicle operation.

! CAUTION

- *Do not use for anything other than glasses.*
- *Do not leave glasses in the sunglasses holder while parking in direct sunlight. The heat may damage the glasses.*

CUP HOLDER

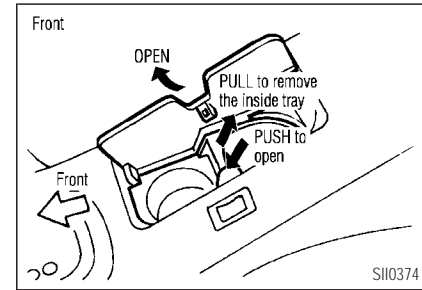

For larger cups, remove the inside tray.

! WARNING

The cup holder should not be used while driving so full attention may be given to vehicle operation.

INSTRUMENTS AND CONTROLS

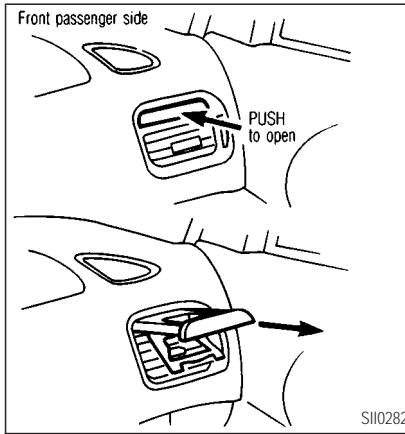

CAUTION

Do not put hot drinks in the instrument panel cup holder.

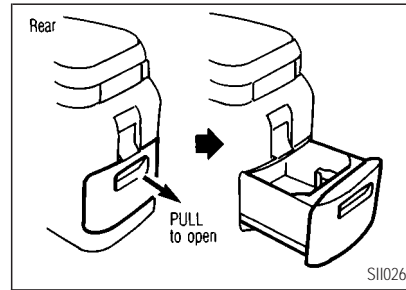

CAUTION

- *Avoid abrupt starting and braking when the cup holder is being used to prevent spilling the drink. If the liquid is hot, it can scald you or your passenger.*
- *Use only soft cups in the cup holder. Hard objects can injure you in an accident.*

GLOVE BOX

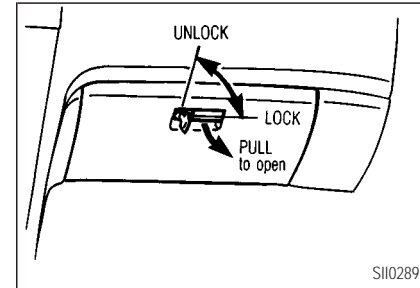

When locking or unlocking the glove box, use the master key or wallet key.

The glove box may be opened by pulling the handle.

WARNING

Keep glove box lid closed while driving to help prevent injury in an accident or a sudden stop.

INSTRUMENTS AND CONTROLS

CONSOLE BOX

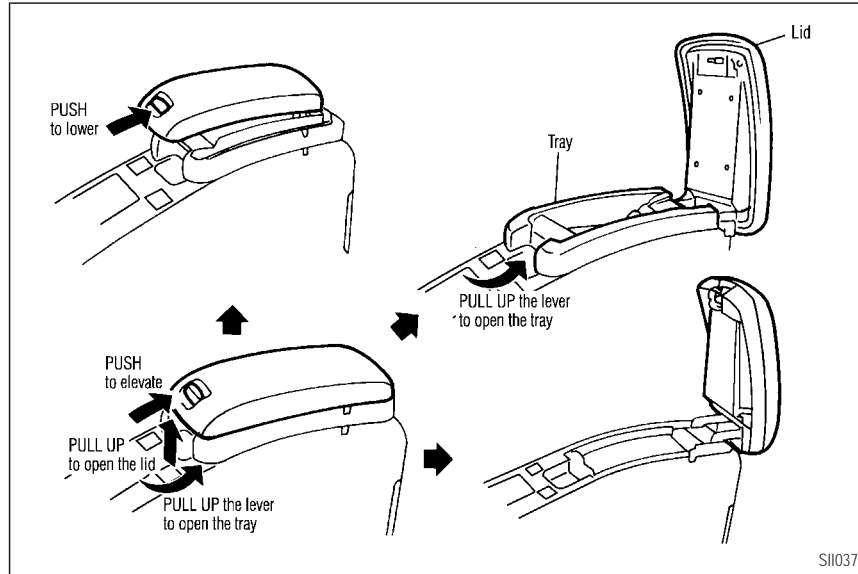

WARNING

The center console box should not be used while driving so full attention may be given to vehicle operation.

CARGO NET (if so equipped)

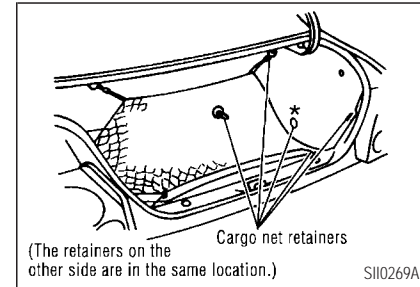

The cargo net helps keep packages in the cargo area from moving around while your vehicle is driven.

INSTRUMENTS AND CONTROLS

- * If the vehicle is equipped with a 215/55HR spare tire, you cannot use the cargo net retainer located here.

To install the cargo net, attach the hooks to the retainers.

To remove the cargo net, detach the hooks from the cargo net retainers.



WARNING

- Properly secure all cargo to help prevent it from sliding or shifting.
- Be sure to secure hooks into the retainers. The cargo restrained in the net must not exceed 30 lb (13.6 kg) or the net may not stay secured.

WINDOWS

POWER WINDOWS



WARNING

- Make sure that all passengers have their hands, etc. inside the vehicle while it is in motion and before closing the windows. Use the window lock switch to prevent unexpected use of the power windows.
- Do not leave children unattended inside the vehicle. They could unknowingly activate switches or controls and become trapped in a window. Unattended children could become involved in serious accidents.

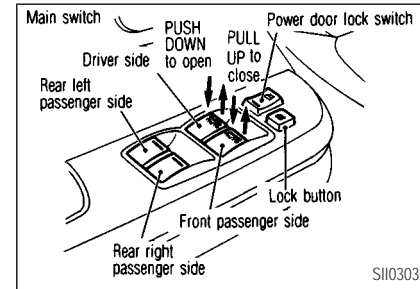

The power windows operate when the ignition key is in the ON position, or for about 45 seconds after the ignition key is turned to the OFF position. If the driver's or front passenger's door is opened during this period of about 45 seconds, power to the windows is cancelled.

To open or close the window, push down or pull up the switch and hold it. The main switch (driver side switches) will open or close all the windows.

INSTRUMENTS AND CONTROLS

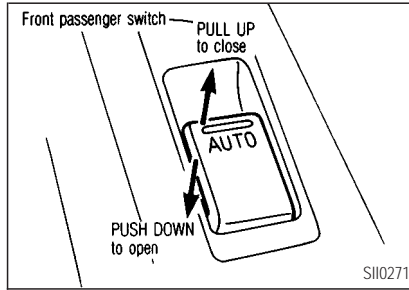

close the window, hold the switch down or up.

Locking passenger's windows

When the lock button is pushed in, only the driver side window can be opened or closed. Push it in again to cancel.

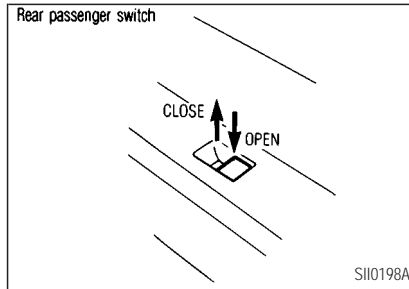

The passenger side switch will open or close only the corresponding window. To open or

Automatic operation

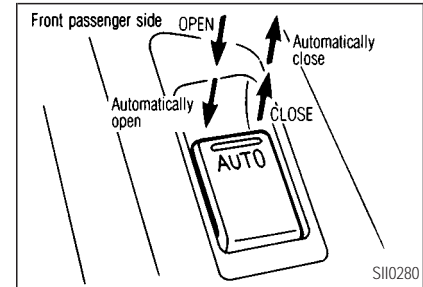
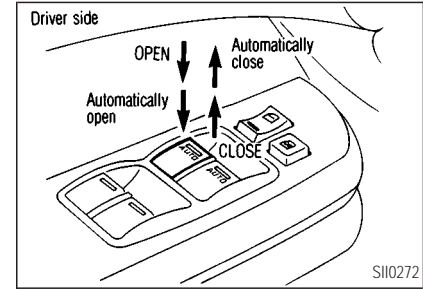

To fully open or close the front window,

INSTRUMENTS AND CONTROLS

completely press or lift the switch and release it; it need not be held. The window will automatically open or close all the way. To stop the window, just press or lift the switch on the opposite side.

Auto reverse function (For front windows)

If the control unit detects something caught in a front window as it moves up, the window will be immediately lowered.

The auto reverse function can be activated when a front window is closed by automatic operation when the ignition key is in the ON position or for about 45 seconds after the ignition key is turned to the OFF position.

Depending on the environment or driving conditions, the auto reverse function may be activated if an impact or load similar to something being caught in the window occurs.



WARNING

There are some small distances immediately before the closed position which cannot be detected. Make sure that all passengers have their hands, etc., inside the vehicle before closing the window.

SUNROOF (if so equipped)

ELECTRIC SUNROOF

The sunroof operates when the ignition key is in the ON position, or for about 45 seconds after the ignition key is turned to the OFF position. If the driver's, or front passenger's door is opened during this period of about 45 seconds, power to the sunroof is canceled.

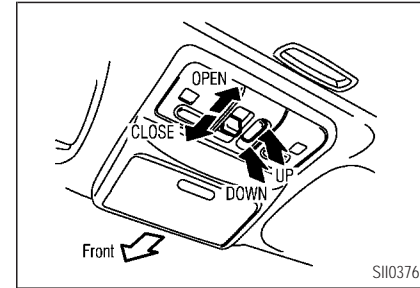

Sliding the sunroof



To open the sunroof, move the slide switch the required distance to the  side.

To close the roof, move the slide switch to the  side.

Sliding position of lid can be chosen according to sliding amount of switch.

To fully open or close the roof, completely move the switch to the  or  side.

INSTRUMENTS AND CONTROLS

Restarting the sunroof sliding switch

The sliding switch will become inoperable after the battery terminal is disconnected, the electrical supply interrupted and/or some abnormality detected.

Use the following re-set procedure to return sunroof operation to normal.

1. If the sunroof lid is open, push the tilting switch repeatedly toward tilt DOWN to fully close the lid.
2. After the lid has closed all the way, keep pushing the tilting switch toward tilt DOWN for more than 1 second.

Auto reverse function (When closing the sunroof)

If the control unit detects something caught in the sunroof as it moves to the front, the sunroof will immediately open backward.

The auto reverse function can be activated

when the sunroof is closed by automatic operation when the ignition key is in the ON position or for about 45 seconds after the ignition key is turned to the OFF position.



Depending on the environment or driving conditions, the auto reverse function may be activated if an impact or load similar to something being caught in the sunroof occurs.



WARNING

There are some small distances immediately before the closed position which cannot be detected. Make sure that all passengers have their hands, etc., inside the vehicle before closing the sunroof.

Tilting the sunroof

To tilt up, first close the sunroof, then press and hold the  side of the tilt switch. To tilt down the sunroof, press and hold the  side.

Sun shade

Open/close the sun shade by sliding it backward/forward.

The shade will open automatically when the sunroof is opened. However, it must be closed manually.



WARNING

- *In an accident you could be thrown from the vehicle through an open sunroof. Always use seat belts and child restraints.*
- *Do not allow anyone to stand up*

INSTRUMENTS AND CONTROLS

or extend any portion of their body out of the opening while the vehicle is in motion or while the sunroof is closing.

CAUTION

- Remove water drops, snow, ice or sand from the sunroof before opening.
- Do not place any heavy object on the sunroof or surrounding area.

If the sunroof does not close

Have your INFINITI retailer check and repair the sunroof.

REAR SUN SHADE (if so equipped)

CAUTION

- To avoid personal injury, keep your hands, fingers and head away from the sun shade arm, arm rail and screen inlet port.
- Do not allow children near the rear sun shade system. They could be injured.
- Do not place objects on or near the rear sun shade. This could cause improper operation or damage it.
- Do not pull or push the rear sun shade. This could cause improper operation or damage it.

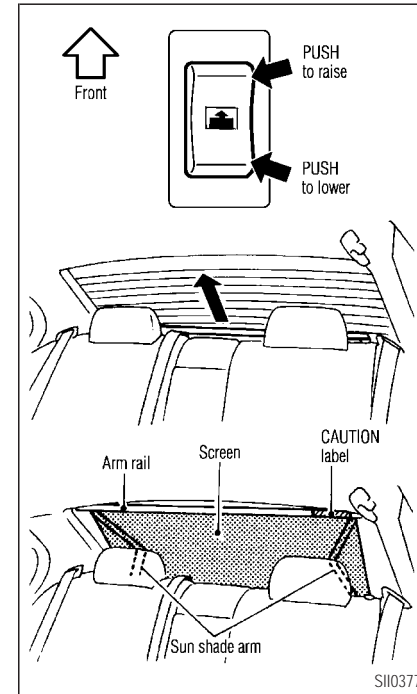

SI10377

INSTRUMENTS AND CONTROLS

The rear sun shade operates when the ignition key is in the ACC or ON position.

To raise the screen, push the UP side of the switch.

To lower the screen, push the DOWN side of the switch.

The switch need not be held down.



CAUTION

- *Do not place objects (such as newspapers, handkerchiefs, etc.) on the screen inlet port. Doing so may entangle these objects in the screen when it is extending or retracting, causing improper operation or damage to the screen.*
- *Do not place any object on the screen inlet port. Improper opera-*

tion or damage to the screen may result.

- *Do not push the sun shade arm with your hands, etc., as this may deform it. Improper operation or damage to the screen may result.*
- *Do not put any object into the screen inlet port as this may result in improper operation or damage the screen.*
- *Do not hang any object on the arm rail as this may result in improper operation or damage the screen.*
- *Do not forcefully pull the screen. Doing so may elongate the screen. Improper operation or damage to the screen may result.*

CLOCK

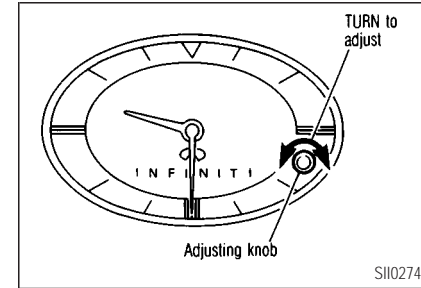

If the power supply is disconnected, the clock will not indicate the correct time. Readjust the time.

ADJUSTING THE TIME

To adjust the time, turn the adjusting knob.

INSTRUMENTS AND CONTROLS

TRIP COMPUTER



The display of the trip computer is situated in the tachometer display. When the ignition is turned to ON, the display scrolls all the modes of the trip computer and then shows the mode chosen before the ignition switch is turned OFF.

If the battery terminal is disconnected, push the trip computer mode switch more than 1 second to activate the computer.

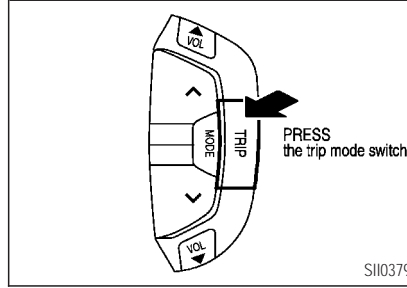

When the ignition switch is turned to ON, modes of the trip computer can be selected by pushing once on the trip mode switch. The following modes can be selected:

Outside air temperature (ICY — °F or °C)

The outside air temperature is displayed in °F or °C.

The outside air temperature mode includes a low temperature warning feature: below 37°F (3°C), the outside air temperature mode is

automatically selected and ICY will illuminate in order to draw the driver's attention. Press the mode switch if you wish to return to the mode that was selected before the warning occurred. The ICY indicator will continue blinking as long as the temperature remains below 39°F (4°C).

Distance to empty (dte — mile or km)

The distance to empty (dte) mode provides you with an estimation of the distance that can be driven before refueling. The dte is constantly being calculated, based on the amount of fuel in the fuel tank and the actual fuel consumption.

The display is updated every 30 seconds.

The dte mode includes a low range warning feature: when the fuel level is low, the dte mode is automatically selected and the digits blink in order to draw the driver's attention. Press the mode switch if you wish to return to

INSTRUMENTS AND CONTROLS

the mode that was selected before the warning occurred. The dte mark (dte) will remain blinking until the vehicle is refueled.

When the fuel level drops even lower, the dte display will change to (----).

NOTE:

- If the amount of fuel added while the ignition switch is OFF is small, the display just before the ignition switch is turned OFF may continue to be displayed.
- When driving uphill or rounding curves, the fuel in the tank shifts, which may momentarily change the display.

Average fuel consumption (Mpg OR l/100km)

The Average fuel consumption mode shows the average fuel consumption since the last reset. Resetting is done by pressing the mode

switch for more than approximately 1 second. The display is updated every 30 seconds. At about the first 1/3 miles (500 m) after a reset, the display shows (----).

Average speed (MPH OR km/h)

The average speed mode shows the average vehicle speed since last reset. Resetting is done by pressing the mode switch for more than approximately 1 second. The display is updated every 30 seconds. The first 30 seconds after a reset, the display shows (----).

Journey time

The journey time mode shows the time since the last reset. The displayed time can be reset by pressing the mode switch for more than approximately 1 second.

NOTE:

If a low temperature warning and low range warning occur simultaneously, other display modes switch automati-

cally to the outside temperature display.

When the mode switch is pushed, the display switches to the mode chosen before the warning display, and the outside air temperature indicator marked ICY will blink.

INTERIOR LIGHT

CEILING

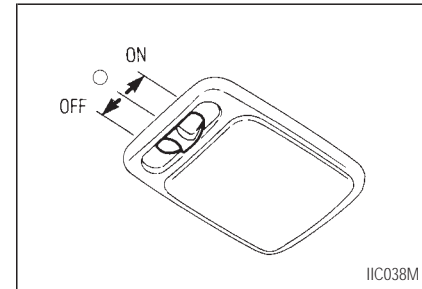

The light has a three-position switch.

When the switch is in the center ○ position,

INSTRUMENTS AND CONTROLS

the light will illuminate when a door is opened.

The light will stay on for about 30 seconds when:

- The driver's door is unlocked by the multi-remote controller, a key or the lock-unlock switch while all doors are closed.
- The driver's door is opened and then closed while the key is removed from the ignition switch.
- The key is removed from the ignition switch while all doors are closed.

The ceiling light will turn off while the 30 second timer is activated, when:

- The driver's door is locked either with the multi-remote controller, a key, or the lock-unlock switch.
- The ignition switch is turned ON.

When the interior light switch or per-

sonal light switch is in the ON position, the interior, personal and vanity mirror lights will automatically turn off 30 minutes after the ignition switch has been turned to the OFF position. To turn on the light again, insert the key into the ignition switch and move it to the ON position.

After the above procedure, the interior, personal or vanity mirror lights will automatically turn off 30 minutes after the latest operation of the following with the ignition switch in the ACC or OFF position:

- Opening or closing any door
- Locking or unlocking with the multi-remote controller, the lock-unlock switch or a key
- Inserting or removing a key from the ignition switch

These lights will turn on again when any of the above operations is performed after the lights

have turned off automatically. (The lights will turn off 30 minutes after the latest operation of the above as well.)



CAUTION

Turn off the interior, personal and vanity mirror lights when you leave the vehicle.

PERSONAL LIGHT

When the interior light switch or personal light switch is in the ON position, the interior, personal and vanity mirror lights will automatically turn off 30 minutes after the ignition switch has been turned to the OFF position. To turn on the light again, insert the key into the ignition switch and move it to the ON position.

After the above procedure, the interior, per-

INSTRUMENTS AND CONTROLS

sonal or vanity mirror lights will automatically turn off 30 minutes after the latest operation of the following with the ignition switch in the ACC or OFF position:

- Opening or closing any door
- Locking or unlocking with the multi-remote controller, the lock-unlock switch or a key
- Inserting or removing a key from the ignition switch

These lights will turn on again when any of the above operations is performed after the lights have turned off automatically. (The lights will turn off 30 minutes after the latest operation of the above as well.)



CAUTION

Turn off the interior, personal and

vanity mirror lights when you leave the vehicle.

FRONT

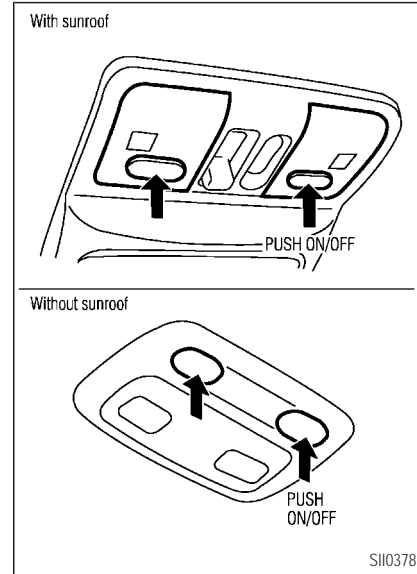

INSTRUMENTS AND CONTROLS

VANITY MIRROR LIGHTS

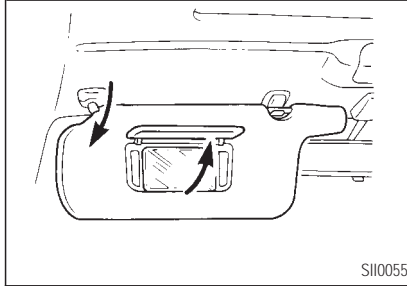

The light on the vanity mirror will turn on when the cover on the vanity mirror is opened.

When the interior light switch or personal light switch is in the ON position, the interior, personal and vanity mirror lights will automatically turn off 30 minutes after the ignition switch has been turned to the OFF position. To turn on the light again, insert the key into the ignition switch and move it to the ON position.

After the above procedure, the interior, personal, vanity mirror or trunk lights will automatically turn off 30 minutes after the latest operation of the following with the ignition switch in the ACC or OFF position:

- Opening or closing any door
- Locking or unlocking with the multi-remote controller, the lock-unlock switch or a key
- Inserting or removing a key from the ignition switch

These lights will turn on again when any of the above operations is performed after the lights have turned off automatically. (The lights will turn off 30 minutes after the latest operation of the above as well.)



CAUTION

Turn off the interior, personal and

vanity mirror lights when you leave the vehicle.

TRUNK LIGHT

The light illuminates when the trunk lid is opened. When the trunk lid is closed, the light will go off.

HomeLink® UNIVERSAL TRANSCEIVER (if so equipped)

The HomeLink® Universal Transceiver provides a convenient way to consolidate the functions of up to three individual hand-held transmitters into one built-in device.

The HomeLink® Universal Transceiver power will automatically turn off 30 minutes after the ignition switch has been turned to the off position.

HomeLink® Universal Transceiver:

INSTRUMENTS AND CONTROLS

- Will operate most Radio Frequency (RF) devices such as garage doors, gates, home and office lighting, entry door locks and security systems.
- Is powered by your vehicle's battery. No separate batteries are required. If the vehicle's battery is discharged or is disconnected, HomeLink® will retain all programming.

Once the HomeLink® Universal Transceiver is programmed, retain the original transmitter for future programming procedures (Example: new vehicle purchases). Upon sale of the vehicle, the programmed HomeLink® Universal Transceiver buttons should be erased for security purposes. For additional information, refer to "Programming HomeLink®" later in this section.



WARNING

- *Do not use the HomeLink® Universal Transceiver with any garage door opener that lacks safety stop and reverse features as required by federal safety standards. (These standards became effective for opener models manufactured after April 1, 1982). A garage door opener which cannot detect an object in the path of a closing garage door and then automatically stop and reverse, does not meet current federal safety standards. Using a garage door opener without these features increases the risk of serious injury or death.*
- *During programming, your ga-*

rage door or gate may open or close. Make sure that people and objects are clear of the garage door or gate that you are programming.

- *Your vehicle's engine should be turned off while programming the HomeLink® Universal Transceiver.*

PROGRAMMING HomeLink®

To program your HomeLink Transceiver to operate a garage door, gate, or entry door opener, home or office lighting, you need to be at the same location as the device. Note: Garage door openers (manufactured after 1996) have "rolling code protection". To program a garage door opener equipped with "rolling code protection"; you will need to use a ladder to get up to the garage door opener

INSTRUMENTS AND CONTROLS

motor to be able to access the “smart or learn” program button.

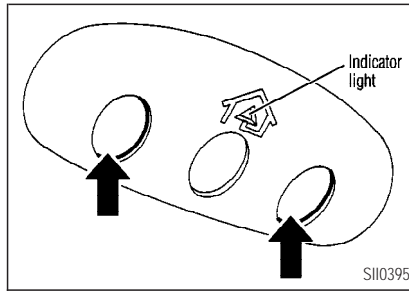

1. To begin, press and hold the 2 outer HomeLink® buttons (to clear the memory) until the indicator light blinks slowly (after 20 seconds). Release both buttons.
2. Position the end of the hand-held transmitter 1-3 inches away from the HomeLink® surface.

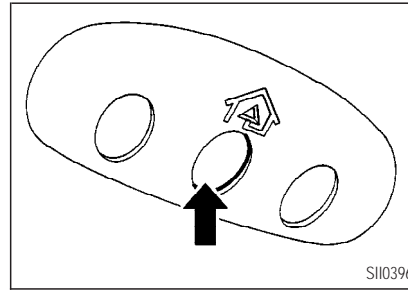

3. Using both hands, simultaneously press and hold both the HomeLink® button you want to program and the hand-held transmitter button.
DO NOT release the buttons until step 4 has been completed.
4. Hold down both buttons until the indicator light on the HomeLink® flashes, changing from a “slow blink” to a “rapidly flashing blink”. This could take up to 90 seconds. When the indicator light flashes rapidly, both buttons may be released. The rapidly

flashing light indicates successful programming. To activate the garage door or other programmed device, press and hold the programmed HomeLink® button - releasing when the device begins to activate.

5. If the indicator light on the HomeLink® blinks rapidly for two seconds and then turns solid, HomeLink® has picked up a “rolling code” garage door opener signal. You will need to proceed with the next steps to train the HomeLink® to complete the programming which may require a ladder and another person for convenience.
6. Press and release the “smart” or “learn” program button located on the garage door opener’s motor to activate the “training mode”. This button is usually located near the antenna wire that hangs down from the motor. If the wire originates from under a light lens, you will need to remove the lens to access the program button.

INSTRUMENTS AND CONTROLS

NOTE:

Once you have pressed and released the program button on the garage door opener's motor and the "training light" is lit, you have 30 seconds in which to perform step 7. Use the help of a second person for convenience to assist when performing this step.

7. Quickly within 30 seconds of pressing and releasing the garage door opener program button, firmly press and release the HomeLink® button you've just programmed. Press and release the HomeLink® button up to three times to complete the training.
8. Your HomeLink® button should now be programmed. (To program the remaining HomeLink® buttons for additional door or gate openers, follow steps 2-8 only.)

NOTE:

Do not repeat step one unless you want

2-42

to "clear" all previously programmed HomeLink® buttons).

If you have any questions or are having difficulty programming your HomeLink® buttons, please refer to the HomeLink® web site at: www.homelink.com or call 1-800-662-6200.

PROGRAMMING HomeLink® FOR CANADIAN CUSTOMERS

Prior to 1992, D.O.C. regulations required hand-held transmitters to stop transmitting after 2 seconds. To program your hand-held transmitter to HomeLink®, continue to press and hold the HomeLink® button (note steps 2 through 4 under "Programming HomeLink® ") while you press and re-press ("cycle") your hand-held transmitter every 2 seconds until the indicator light flashes rapidly (indicating successful programming).

NOTE:

If programming a garage door opener,

etc., it is advised to unplug the device during the "cycling" process to prevent possible damage to the garage door opener components.

OPERATING THE HomeLink® UNIVERSAL TRANSCEIVER

The HomeLink® Universal Transceiver (once programmed) may now be used to activate the garage door, etc. To operate, simply press the appropriate programmed HomeLink® Universal Transceiver button. The red indicator light will illuminate while the signal is being transmitted.

PROGRAMMING TROUBLE DIAGNOSIS

If the HomeLink® does not quickly learn the hand-held transmitter information:

- replace the hand-held transmitter batteries with new batteries.
- position the hand-held transmitter with its

INSTRUMENTS AND CONTROLS

battery area facing away from the HomeLink® surface.

- press and hold both the HomeLink® and hand-held transmitter buttons without interruption.
- position the hand-held transmitter 2 to 5 inches (50 to 127 mm) away from the HomeLink® surface. Hold the transmitter in that position for up to 15 seconds. If HomeLink® is not programmed within that time, try holding the transmitter in another position - keeping the indicator light in view at all times.

If you continue to have programming difficulties, please contact the INFINITI Consumer Affairs Department. The phone numbers are located in the Foreword of this Owner's Manual.

CLEARING THE PROGRAMMED INFORMATION

Individual buttons cannot be cleared, however

to clear all programming, press and hold the two outside buttons and release when the indicator light begins to flash (approximately 20 seconds).

REPROGRAMMING A SINGLE HomeLink® BUTTON

To reprogram a HomeLink® Universal Transceiver button, complete the following.

1. Press and hold the desired HomeLink® button. **Do not** release the button until step 4 has been completed.
2. When the indicator light begins to flash slowly (after 20 seconds), position the hand-held transmitter 2 to 5 inches (50 to 127 mm) away from the HomeLink® surface.
3. Press and hold the hand-held transmitter button.
4. The HomeLink® indicator light will flash, first slowly and then rapidly. When the

indicator light begins to flash rapidly, release both buttons.

The HomeLink® Universal Transceiver button has now been reprogrammed. The new device can be activated by pushing the HomeLink® button that was just programmed. This procedure will not affect any other programmed HomeLink® buttons.

IF YOUR VEHICLE IS STOLEN

If your vehicle is stolen, you should change the codes of any non-rolling code device that has been programmed into HomeLink®. Consult the Owner's Manual of each device or call the manufacturer or dealer of those devices for additional information.

When your vehicle is recovered, you will need to reprogram the HomeLink® Universal Transceiver with your new transmitter information.

INSTRUMENTS AND CONTROLS

FCC Notice:

This device complies with FCC rules part 15. Operation is subject to the following two conditions: (1) This device may not cause harmful interference and (2) This device must accept any interference that may be received, including interference that may cause undesired operation.

The transmitter has been tested and complies with FCC and DOC/MDC rules. Changes or modifications not expressly approved by the party responsible for compliance could void the user's authority to operate the device.

DOC: ISTC 1763K1313

FCC I.D.: CB2V67690

3 PRE-DRIVING CHECKS AND ADJUSTMENTS

Keys	3-2	Interior trunk lid release.....	3-12
Doors	3-3	Fuel filler lid.....	3-13
Locking with key	3-3	Opener operation.....	3-13
Front window open/close with key	3-3	Fuel filler cap.....	3-13
Locking with inside lock knob	3-4	Steering wheel	3-15
Locking with power door lock switch....	3-4	Tilt operation.....	3-15
Child safety rear door lock.....	3-4	Sun visors.....	3-16
Remote keyless entry system	3-5	Mirrors.....	3-16
How to use remote keyless entry		Automatic anti-glare inside mirror	3-16
system.....	3-5	Outside mirrors	3-18
Battery replacement	3-9	Automatic seat positioner.....	3-19
Hood	3-10	Automatic seat positioner operation	3-19
Trunk lid	3-11	Procedure for storing memory	3-19
Opener operation.....	3-11	Cancel switch	3-21
Rear seat trunk release	3-12		

PRE-DRIVING CHECKS AND ADJUSTMENTS

KEYS

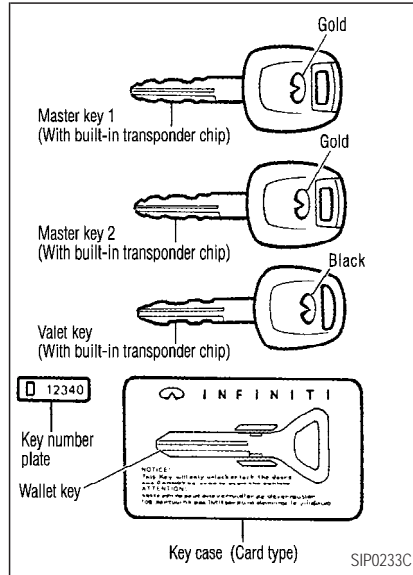

You can only drive your vehicle using the master or valet keys which are registered to

the Infiniti Vehicle Immobilizer System components in your vehicle. These keys have a transponder chip in the key head. (The wallet key cannot be used to drive your vehicle.)

The master key and wallet key can be used for all the locks.

When the key case with the wallet key is placed into your wallet, be careful not to apply excessive force to the wallet as it or other cards could be damaged.

The valet key cannot be used for the trunk lid or glove box locks.

To protect belongings when you leave a key with someone, give them the valet key only.

Never leave these keys in the vehicle.

Record the key number on the key number plate supplied with your keys and keep it in a safe place (such as your wallet), not in the vehicle. INFINITI does not record any key numbers so it is very important to keep track

of your key number plate.

A key number is only necessary when you have lost all keys and do not have one to duplicate from. If you still have a key, this key can be duplicated by your INFINITI retailer.

INFINITI VEHICLE IMMOBILIZER SYSTEM KEY - Master and Security keys:

The key number is necessary when you need extra Infiniti Vehicle Immobilizer System keys. As many as 5 Infiniti Vehicle Immobilizer System keys can be used with one vehicle. New keys must be registered to the Infiniti Vehicle Immobilizer System components in your vehicle by your INFINITI retailer. At this time, you should bring all Infiniti Vehicle Immobilizer System keys that you have to your INFINITI retailer for registration. This is because the registration process will erase all memory of the Infiniti Vehicle Immobilizer System components.

PRE-DRIVING CHECKS AND ADJUSTMENTS

DOORS

WARNING

- *Always have the doors locked while driving. Along with the use of seat belts, this provides greater safety in the event of an accident by helping to prevent persons from being thrown from the vehicle. This also helps keep children and others from unintentionally opening the doors, and will help keep out intruders.*
- *Before opening any door, always look for and avoid oncoming traffic.*

- *Do not leave children unattended inside the vehicle. They could unknowingly activate switches or controls. Unattended children could become involved in serious accidents.*

LOCKING WITH KEY

Power

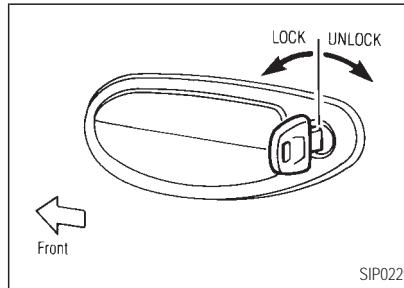

The power door lock system allows you to lock or unlock all doors simultaneously.

- Turning the driver's door key to the front of the vehicle will lock all doors.
- Turning the driver's door key one time to the rear of the vehicle will unlock the corresponding door. From that position, returning the key to neutral (where the key can only be removed and inserted.) and turning it to the rear again within 5 seconds will unlock all doors.

FRONT WINDOW OPEN/CLOSE WITH KEY

Turn the door key to unlock position and hold for 1 second, the front window will begin to lower.

To stop opening, turn the key to the neutral position.

To close the front window with the door key cylinder, turn the key to lock position and hold for 1 second.

PRE-DRIVING CHECKS AND ADJUSTMENTS

To stop closing, turn the key to the neutral position.

In the event of a hand in the way, or other obstruction, the auto reverse function will activate.

LOCKING WITH INSIDE LOCK KNOB

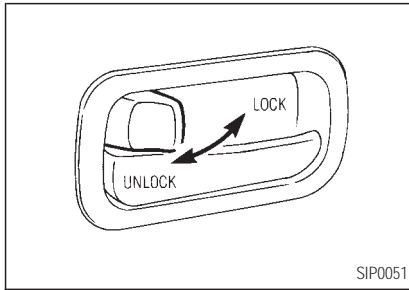

To individually lock the doors, move the inside lock knob to the LOCK position, then close the door. To unlock, pull up the inside lock knob to the unlock position.

When locking the door without a key, be sure not to leave the key inside the vehicle.

LOCKING WITH POWER DOOR LOCK SWITCH

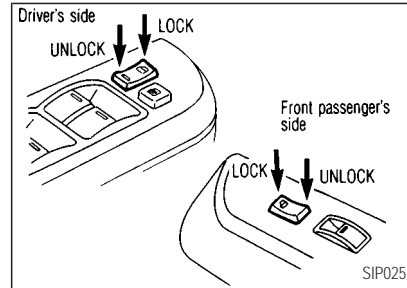

All door locks will be engaged when the power door lock switch is moved to the LOCK position with the driver's or front passenger's door open. Then close the door and all doors will be locked.

When the power door lock switch is moved to

the LOCK position while a key is in the ignition switch and any door is open, all doors will lock once and then unlock automatically.

CHILD SAFETY REAR DOOR LOCK

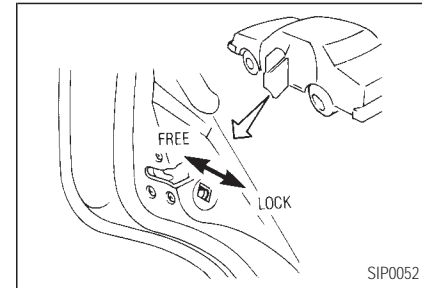

Child safety locking helps prevent doors from being opened accidentally, especially when small children are in the vehicle.

When the lever is in the lock position, the rear door can be opened only from the outside.

PRE-DRIVING CHECKS AND ADJUSTMENTS

REMOTE KEYLESS ENTRY SYSTEM

It is possible to lock/unlock all doors and activate the panic alarm by using the keyfob from outside the vehicle.

Before locking the doors, make sure the key is not left in the vehicle.

The keyfob can operate at a distance of approximately 33 ft (10 m) from the vehicle. (The effective distance depends upon the conditions around the vehicle.)

As many as four keyfobs can be used with one vehicle. For information concerning the purchase and use of additional keyfobs, contact your INFINITI retailer.

The keyfob will not function when:

- the battery is dead,
- the distance between the vehicle and the keyfob is over 33 ft (10 m).

The panic alarm will not activate when

the key is in the ignition switch.



CAUTION

The following conditions or occurrences will damage the keyfob.

- *Do not allow the keyfob to become wet.*
- *Do not drop the keyfob.*
- *Do not strike the keyfob sharply against another object.*
- *Do not place the keyfob for an extended period in an area where temperatures exceed 140°F (60°C).*

If a keyfob is lost or stolen, INFINITI recommends erasing the ID code of that controller. This will prevent the controller from unauthorized use to

unlock the vehicle. For information regarding the erasing procedure, please contact an authorized INFINITI retailer.

HOW TO USE REMOTE KEYLESS ENTRY SYSTEM

Setting hazard and horn chirp mode

This vehicle is set in hazard and horn chirp mode when you first receive the vehicle.

In hazard and horn chirp mode, when the LOCK button is pushed, the hazard indicator flashes twice and the horn chirps once. When the UNLOCK button is pushed, the hazard indicator flashes once.

If hazard and horn chirp mode is not necessary, you can switch to normal mode by following the switching procedure.

PRE-DRIVING CHECKS AND ADJUSTMENTS

In normal mode, when the LOCK button is pushed, the hazard indicator flashes twice. When the UNLOCK button is pushed, neither the hazard indicator nor the horn operates.

(Switching procedure)

Push the LOCK and UNLOCK buttons on the keyfob simultaneously for more than 2 seconds to switch from one mode to the other.

When pushing the buttons to set normal mode, the hazard indicator flashes 3 times.

When pushing the buttons to set hazard and horn chirp mode, the hazard indicator flashes once and the horn chirps once.

OPERATION GUIDE

MODE (Push "LOCK" and "UNLOCK" buttons for more than 2 seconds to switch)	Switching indicator	LOCK	UNLOCK
Hazard and horn chirp → NORMAL	HAZARD — 3 times	HAZARD — twice	No operation
Normal → HAZARD AND HORN CHIRP	HAZARD — once HORN — once	HAZARD — twice HORN — once	HAZARD — once

SIP0247

Locking doors

1. Remove the ignition key.*1
2. Close all the doors.*2
3. Push the LOCK button on the keyfob.
4. All the doors will lock.

All of the doors will lock when the LOCK

button on the keyfob is pushed even though a door remains open and/or the ignition key is in the ON position.

5. The hazard indicator flashes twice and the horn chirps once.
- When the LOCK button is pushed with all doors locked, the hazard indicator flashes

PRE-DRIVING CHECKS AND ADJUSTMENTS

twice and the horn chirps once as a reminder that the doors are already locked.

*1: Doors lock with the keyfob while a key is in the ignition switch. However, the panic alarm will not activate when the key is in the ignition switch.

*2: Doors lock with the keyfob while any door is open. However, hazard and horn chirp mode will not function.

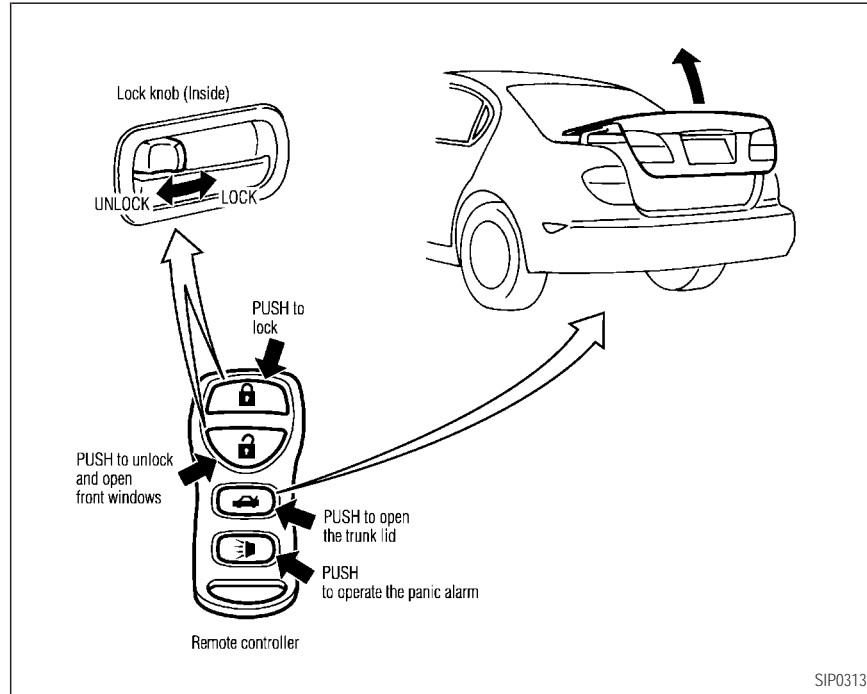

PRE-DRIVING CHECKS AND ADJUSTMENTS

Unlocking doors

1. Pushing the UNLOCK button on the keyfob once.
 - Only the driver's door unlocks
 - The hazard indicator flashes once if all doors are completely closed with the ignition key in any position except the ON position.
 - The interior light turns on and the light timer activates for 30 seconds when the switch is in the center ○ position with the ignition key in any position except the ON position.
2. Push the UNLOCK button on the keyfob again within 5 seconds.
 - All doors unlock
 - The hazard indicator flashes once if all doors are completely closed.

If the following operation is not carried

out within 5 minutes after pressing the UNLOCK button, all doors will be locked automatically.

- **When any door is not opened.**
- **When the ignition key is not set in the ON position.**

The interior light can be turned off without waiting for 30 seconds by turning the ignition switch to the ON position or by locking the doors with the keyfob.

Opening the front window

Push the UNLOCK button on the keyfob.

The driver's door will unlock.

Continue to press the UNLOCK button for 3 seconds. The driver's and front passenger's windows will be lowered.

Continue to press the UNLOCK button until windows are fully open.

To stop lowering the windows, release the UNLOCK button.

To start lowering the windows, press the UNLOCK button again for 3 more seconds.

This function will operate after the ignition switch is off and 45 seconds passed or either the front door is opened.

Releasing the trunk lid

1. Push the TRUNK button on the keyfob for longer than 0.5 second with the key removed from the ignition key cylinder.
2. The trunk lid opens.

The trunk lid will not open when the trunk lid cancel lever is in the CANCEL position. It can be opened only with the key.

See "Trunk lid" later in this section for cancel lever.

Using the panic alarm

If you are near your vehicle and feel threat-

PRE-DRIVING CHECKS AND ADJUSTMENTS

ened, you may activate the alarm to call attention as follows:

1. Push the PANIC button on the keyfob for **longer than 0.5 seconds**.
2. The theft warning alarm and headlights will stay on for 30 seconds.
3. The panic alarm stops when:
 - It has run for 30 seconds, or
 - The LOCK or the UNLOCK button is pressed, or
 - The panic button or trunk lid release button is pushed on the keyfob for longer than 0.5 seconds.

BATTERY REPLACEMENT

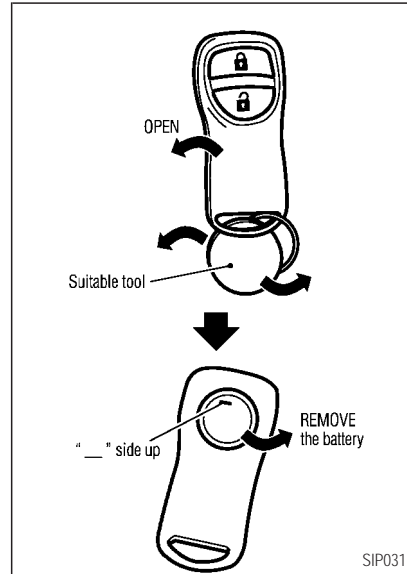

Replace the battery as follows:

1. Open the lid using a suitable tool.
2. Replace the battery with a new one.
Recommended battery: Sanyo CR2025 or equivalent

Make sure that the ⊕ side faces the bottom case.

3. Close the lid securely.
4. Push the keyfob button two or three times to check its operation.

See your INFINITI retailer if you need any assistance for replacement.

If the battery is removed for any reason other than replacement, perform step 4 above.

- **An improperly disposed battery can harm the environment. Always confirm local regulations for battery disposal.**

PRE-DRIVING CHECKS AND ADJUSTMENTS

- The keyfob is water-proof; however, if it does get wet, immediately wipe completely dry.
- When changing batteries, do not let dust or oil get on the controller.

FCC Notice:

Changes or modifications not expressly approved by the manufacturer compliance could void the user's authority to operate the equipment.

This device complies with Part 15 of the FCC Rules and RSS-210 of Industry Canada.

Operation is subject to the following two conditions: (1) This device may not cause harmful interference, and (2) this device must accept any interference received, including interference that may cause undesired operation of the device.

HOOD

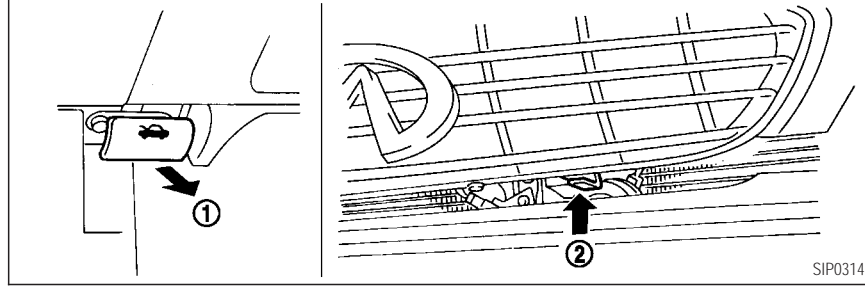

1. Pull the hood lock release handle ① located below the instrument panel; the hood will then spring up slightly.
2. Pull the lever ② at the front of the hood with your fingertips and raise the hood.
3. When closing the hood, slowly close the hood and make sure it locks into place.

WARNING

- *Make sure the hood is completely closed and latched before driving. Failure to do so could cause the hood to fly open and result in an accident.*
- *If you see steam or smoke coming*

PRE-DRIVING CHECKS AND ADJUSTMENTS

from the engine compartment, to avoid injury do not open the hood.

the car locked, with the trunk closed, when not in use, and prevent children's access to car keys.

TRUNK LID

WARNING

- *Do not drive with the trunk lid open. This could allow dangerous exhaust gases to be drawn into the vehicle. See "Precautions when starting and driving" in the "5. Starting and driving" section for exhaust gas.*
- *Closely supervise children when they are around cars to prevent them from playing and becoming locked in the trunk where they could be seriously injured. Keep*

OPENER OPERATION

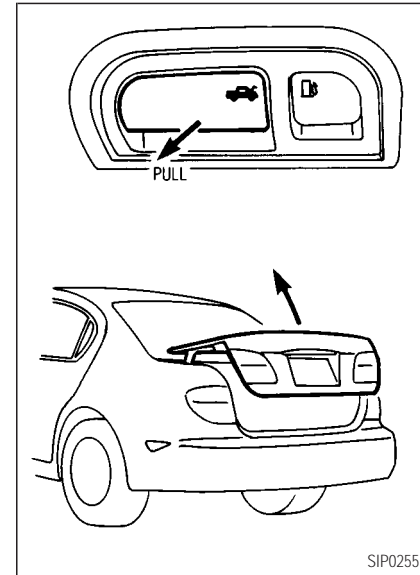

The trunk lid release button is located under the driver's arm rest. To open the trunk lid,

PRE-DRIVING CHECKS AND ADJUSTMENTS

pull the release button.

To close, push the trunk lid down securely.

Cancel lever

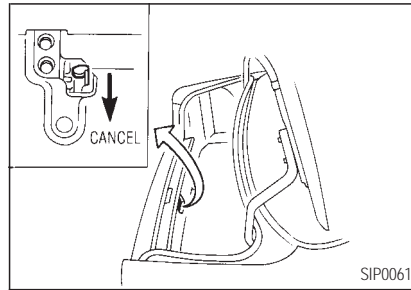

When the lever is in the cancel position, the trunk lid cannot be opened with the trunk lid release button. It can be opened only with the string handle.

REAR SEAT TRUNK RELEASE

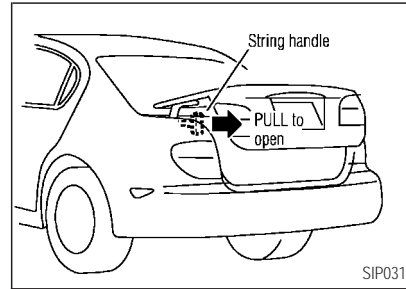

To open the trunk lid from the rear seat, fold the rear seat and pull the rear seat trunk release handle. To close, push the trunk lid down securely.

INTERIOR TRUNK LID RELEASE

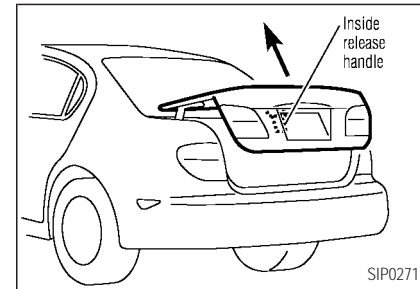

WARNING

Closely supervise children when they are around cars to prevent them from playing and becoming locked in the trunk where they could be seriously injured. Keep the car locked, with the trunk closed, when not in use, and prevent children's access to car

PRE-DRIVING CHECKS AND ADJUSTMENTS

keys.

The interior trunk lid release mechanism provides a means of escape for children and adults in the event they become locked inside the trunk.

To open the trunk lid from the inside, pull the release handle towards you until the lock releases and push up on the trunk lid. The release lever is made of a material that glows in the dark after a brief exposure to ambient light.

The handle is located on the back side of the trunk lid inside the trunk compartment.

FUEL FILLER LID OPENER OPERATION

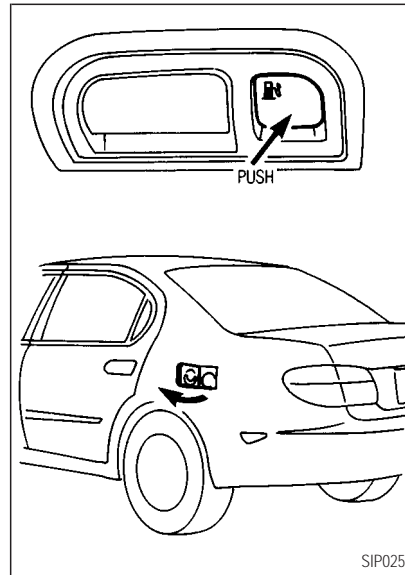

To open the fuel filler lid, push the opener switch. To lock, close the fuel filler lid securely.

FUEL FILLER CAP



WARNING

- *Gasoline is extremely flammable and highly explosive under certain conditions. You could be burned or seriously injured if it is misused or mishandled. Always stop the engine and do not smoke or allow open flames or sparks near the vehicle when refueling.*
- *Fuel may be under pressure. Turn the cap a quarter turn, and wait for any hissing sound to stop to prevent fuel from spraying out and possible personal injury.*

PRE-DRIVING CHECKS AND ADJUSTMENTS

Then remove the cap.

- Do not attempt to top off the fuel tank after the fuel pump nozzle shuts off automatically. Continued refueling may cause fuel overflow, resulting in fuel spray and possibly a fire.
- Use only an original equipment type fuel filler cap as a replacement. It has a built-in safety valve needed for proper operation of the fuel system and emission control system. An incorrect cap can result in a serious malfunction and possible injury. It could also cause the SERVICE ENGINE SOON malfunction indicator lamp to come on.
- Never pour fuel into the throttle body to attempt to start your vehicle.

- Do not fill a portable fuel container in the vehicle or trailer. Static electricity can cause an explosion of flammable liquid, vapor or gas in any vehicle or trailer. To reduce the risk of serious injury or death when filling portable fuel containers:
 - Always place the container on the ground when filling.
 - Do not use electronic devices while filling.
 - Keep the pump nozzle in contact with the container while you are filling it.
 - Use only approved portable fuel containers for flammable liquid.



CAUTION

- If fuel is spilled on the car body,

flush it away with water to avoid paint damage.

- Tighten until the fuel filler cap clicks. Failure to tighten the fuel filler cap properly may cause the SERVICE ENGINE SOON malfunction indicator lamp (MIL) to illuminate. If the SERVICE ENGINE SOON lamp illuminates because the fuel filler cap is loose or missing, tighten or install the cap and continue to drive the vehicle. The SERVICE ENGINE SOON lamp should turn off after a few driving trips. If the SERVICE ENGINE SOON lamp does not turn off after a few driving trips, have the vehicle inspected by an authorized INFINITI retailer.
- For additional information, see the “Malfunction indicator lamp (MIL)” in the “2. Instruments and controls” section.

PRE-DRIVING CHECKS AND ADJUSTMENTS

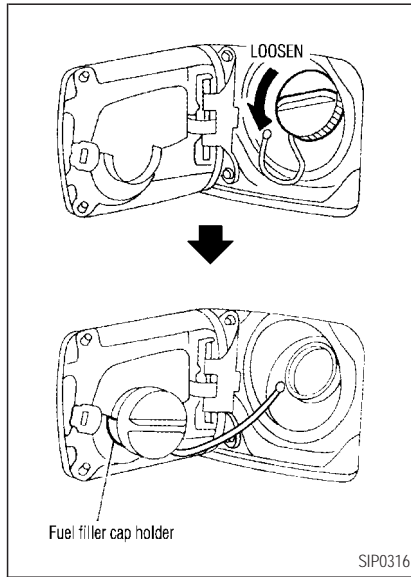

The fuel filler cap is a ratcheting type. Tighten the cap clockwise until ratcheting clicks are heard.

Put the fuel filler cap on the cap holder while refueling.

STEERING WHEEL



WARNING

Do not adjust the steering wheel while driving. You could lose control of your vehicle and cause an accident.

TILT OPERATION

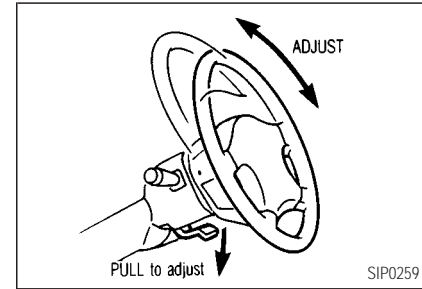

Pull the lock lever and while holding down, adjust the steering wheel up or down to the desired position.

Push the lock lever back into place to lock the steering wheel in place.

PRE-DRIVING CHECKS AND ADJUSTMENTS

SUN VISORS

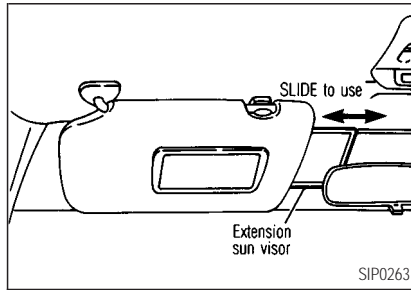

Store the main sun visor after storing the extension sun visor.

MIRRORS

AUTOMATIC ANTI-GLARE INSIDE MIRROR

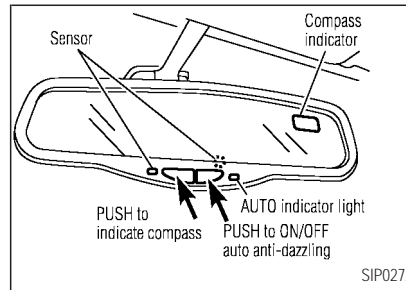

The inside mirror is designed so that it automatically changes reflection according to the intensity of the headlight of the following vehicle.



Use the AUTO position only when necessary, because it reduces rear view clarity.

When the mirror switch is in the ON position, AUTO indicator light remains on and excessive glare from the headlights of the vehicle behind you will be reduced automatically. When the switch is in the OFF position, the inside mirror will operate normally.

When the COMP switch is in the ON position, the compass display will indicate the heading direction of the vehicle.

If the display reads "C", calibrate the compass by driving the vehicle in 3 complete circles at less than five mph.

**The compass needs to be calibrated.
Drive the vehicle in 3 circles at five mph**

PRE-DRIVING CHECKS AND ADJUSTMENTS

or less until the display reads a direction. You can also calibrate the compass by driving your vehicle on your everyday routine. The compass will be calibrated once it has tracked 3 complete circles.

Zone variation change procedure

The difference between magnetic north and geographical north is known as variance. In some areas, this difference can sometimes be great enough to cause false compass readings. Follow these instructions to set the variance for your particular location if this happens:

1. Press the "COMPASS" switch for more than 3 seconds. The current zone number will appear in the display.
2. Find your current location and variance one number on the zone map.
3. Press the "COMPASS" switch until the new zone number appears in the display. After you stop pressing the button in, the

display will show a compass direction within a few seconds.

Inaccurate compass direction:

1. With the display turned on, push the "COMP" switch for 3 seconds, until the zone selection comes up (a number will be displayed in the mirror compass window).
2. Toggle until correct zone is found and release switch.
3. The display will show all segments, and return to the normal compass mode within 10 seconds of no switch activity.
4. If the vehicle changes zone, repeat steps 1 thru 3. See map.
 - If the compass deviates from the correct indication soon after repeated adjustment, have the compass checked at an authorized dealer.
 - The compass may not indicate the correct compass point in tunnels or while driving

up or down a steep hill.

(The compass returns to the correct compass point when the vehicle moves to an area where the geomagnetism is stabilized.)



CAUTION

- ***Do not install a ski rack, antenna, etc. which are attached to the vehicle by means of a magnet. They affect the operation of the compass.***
- ***When cleaning the mirror, use a paper towel or similar material dampened with glass cleaner. Do not spray glass cleaner directly on the mirror as it may cause the liquid cleaner to enter the mirror housing.***

PRE-DRIVING CHECKS AND ADJUSTMENTS

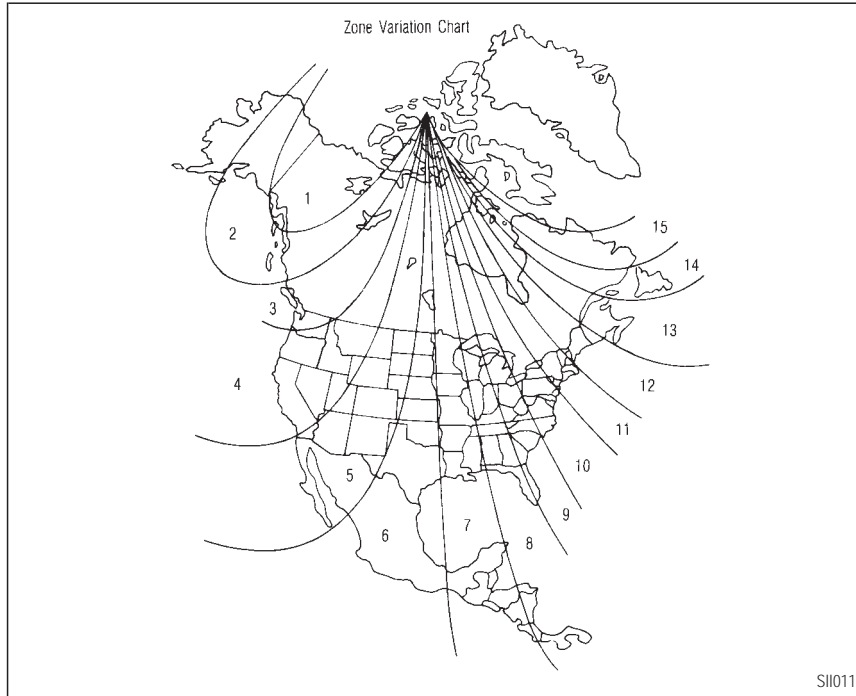

3-18

OUTSIDE MIRRORS

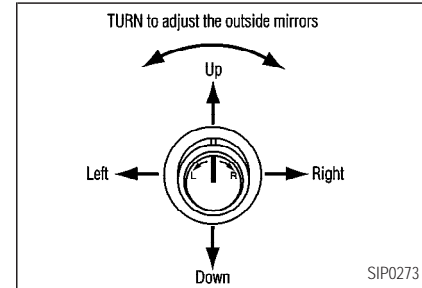

The outside mirror will operate only when the ignition switch is in the ACC or ON position.

Turn the control knob to the right or left to select the right or left outside mirror, then adjust using the control knob.

PRE-DRIVING CHECKS AND ADJUSTMENTS



WARNING

Objects viewed in the outside mirror on the passenger side are closer than they appear. Be careful when moving to the right. Using only this mirror could cause an accident. Use inside mirror or glance over your shoulder to properly judge distances to other objects.

Foldable outside mirrors

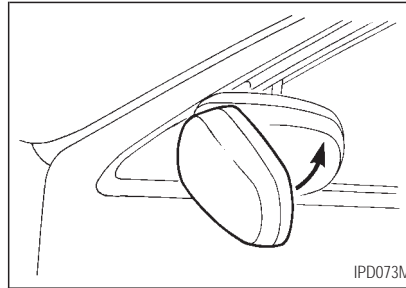

Push the outside mirror backward to fold it.

AUTOMATIC SEAT POSITIONER

AUTOMATIC SEAT POSITIONER OPERATION

This system is designed so that the driver's seat will automatically move when the automatic transmission selector lever is in the P (Park) position. This allows the driver to get into and out of the driver's seat more easily.

When one of the following conditions is met, the driver's seat will slide backward:

- When the key is removed from the ignition switch.
- When the driver's door is opened with the key turned to ACC or LOCK.
- When the key is turned from ON to ACC with the driver's door open.

When one of the following conditions is met, the driver's seat will return to the positions before being set.

- When the key is inserted into the ignition switch.
- When the driver's door is closed with the key turned to LOCK.

PROCEDURE FOR STORING MEMORY

Two positions can be stored in the automatic driver's seat positioner memory. **Follow**

PRE-DRIVING CHECKS AND ADJUSTMENTS

these procedures to use the memory system.

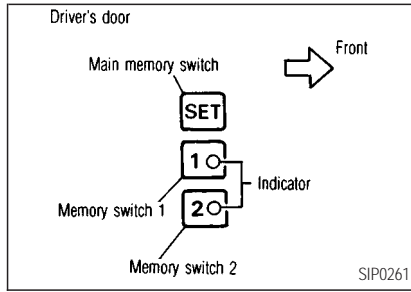

1. Set the automatic transmission selector lever to the P (Park) position.
2. Turn the ignition ON.
3. Adjust the driver's seat to the desired positions by manually operating each adjusting switch. For additional information, see "Seats" in the "1. Seats, restraints and supplemental air bag systems" section.

During this step, do not turn the ignition to

any positions other than ON.

4. Push the SET switch and, within 5 seconds, push the memory switch 1 or 2 fully for at least 1 second.

The indicator light for the pushed memory switch will come on and stay on for approximately 5 seconds after pushing the switch. After the indicator light goes off, the selected positions are stored in the selected memory (1 or 2).

If memory is stored in the same memory switch, the previous memory will be deleted.

Confirming memory storage

- Turn the ignition ON and push the SET switch. If the main memory has not been stored, the indicator light will come on for approximately 0.5 seconds. When the memory has stored the position, the indicator light will stay on for approximately 5 seconds.

- If the battery cable is disconnected, or if the fuse blows, the memory will be canceled. In such a case, reset the desired positions using the following procedures.

1. Open and close the driver's door more than two times with the ignition key in the LOCK position.
2. Reset the desired position using the previous procedure.

Selecting the memorized position

1. Set the automatic transmission selector lever to the P (Park) position.
2. Turn the ignition ON.
3. Push the memory switch 1 or 2 fully for at least 1 second.

The driver's seat will move to the memorized position with the indicator light flashing. Then the light will stay on for approximately 5 seconds.

PRE-DRIVING CHECKS AND ADJUSTMENTS

When the memory switch 1 or 2 is pushed with the driver's door open and then the key inserted into the ignition switch within approximately 1 minute, the driver's seat will move to the memorized position.

System operation

The automatic drive positioner system will not work or will stop operating under the following conditions:

- when the vehicle speed is above 4 MPH (7 km/h).
- when any two or more of the memory switches are simultaneously pressed while the automatic drive positioner is operating.
- when the adjusting switch for the driver's seat is turned on while the automatic drive positioner is operating.
- when the cancel switch located on the instrument panel is pushed to cancel.
- when the memory switch 1 or 2 is not

pushed for at least 1 second.

- when the seat has already been moved to memorized position.
- when no seat position is stored in the memory switch.

CANCEL SWITCH

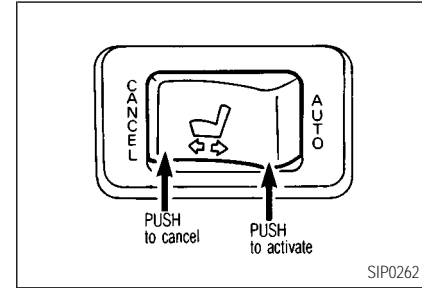

When the CANCEL side of the switch is pushed, the automatic drive positioner system will not function.

When the AUTO side of the switch is pushed, the system will function.

4 HEATER, AIR CONDITIONER AND AUDIO SYSTEMS

Ventilators.....	4-2	Audio operation precautions.....	4-8
Heater and air conditioner (Automatic).....	4-3	FM-AM-SAT radio with cassette player and compact disc (CD) player/CD changer.....	4-12
Automatic operation.....	4-4	FM-AM-SAT radio with cassette player.....	4-20
Manual operation.....	4-5	CD care and cleaning.....	4-27
Operating tips.....	4-5	Steering wheel switch for audio control (if so equipped).....	4-27
In-cabin microfilter.....	4-6	Antenna.....	4-28
Servicing air conditioner.....	4-6	Compact disc (CD) autochanger (if so equipped).....	4-29
Audio system.....	4-7	Car phone or CB radio.....	4-30
Radio.....	4-7		
FM radio reception.....	4-7		
AM radio reception.....	4-8		
Satellite radio reception (if so equipped).....	4-8		

HEATER, AIR CONDITIONER AND AUDIO SYSTEMS

VENTILATORS

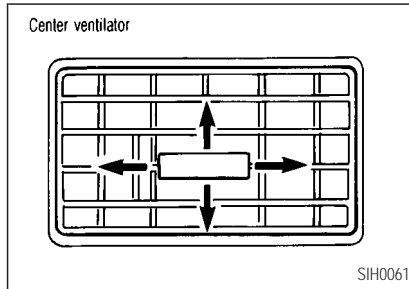

Adjust the air flow direction of ventilators.

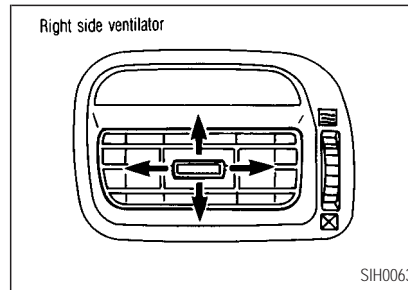
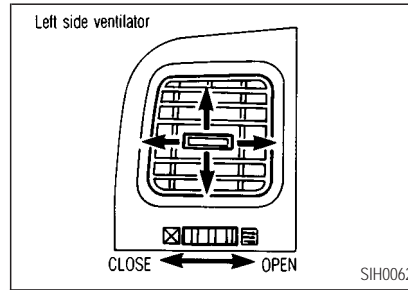

Open or close, and adjust the air flow direction of ventilators.

☒ : This symbol indicates that the vents are closed when the vent switch is moved to the left.

☒☒☒ : This symbol indicates that the vents are open when the vent switch is moved to the right.

HEATER, AIR CONDITIONER AND AUDIO SYSTEMS

HEATER AND AIR CONDITIONER (Automatic)

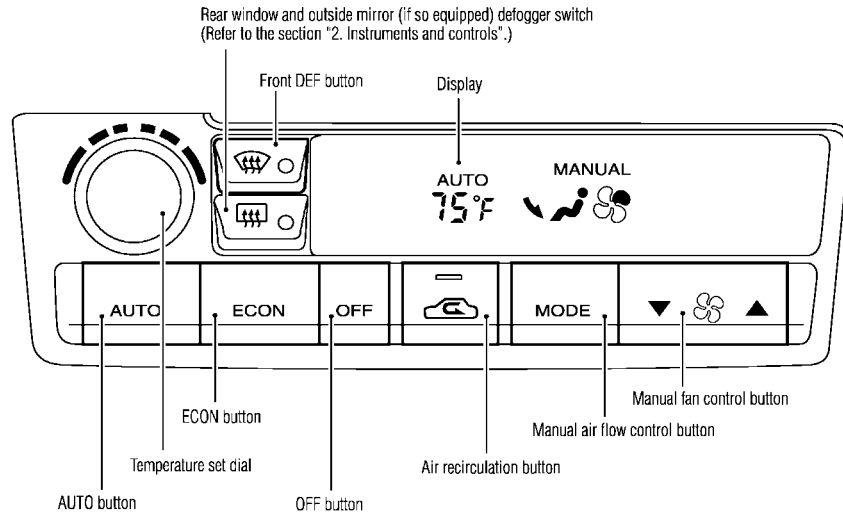

HEATER, AIR CONDITIONER AND AUDIO SYSTEMS

Start the engine and operate the controls to activate the air conditioner.



WARNING

- *The air conditioner cooling function operates only when the engine is running.*
- *Do not leave children or adults who would normally require the support of others alone in your vehicle. Pets should not be left alone either. On hot, sunny days, temperatures in a closed vehicle could quickly become high enough to cause severe or possibly fatal injuries to people or animals.*
- *Do not use the recirculation mode for long periods as it may cause the interior air to become stale*

and the windows to fog up.

- *Positioning of the heater and air conditioner controls should not be done while driving. So full attention may be given to vehicle operation.*

AUTOMATIC OPERATION

Cooling and/or dehumidified heating (AUTO)

This mode may be normally used all year round as the system automatically works to keep a constant temperature. Air flow distribution and fan speed are also controlled automatically.

1. Push the AUTO button on. (AUTO will be displayed.)
 2. Turn the temperature set button to the right or left to set the desired temperature.
- Adjust the temperature set button to about

75°F (24°C) for normal operation.

- The temperature of the passenger compartment will be maintained automatically. Air flow distribution and fan speed are also controlled automatically.





Heating (ECON)

The air conditioner does not activate. When you need to heat only, use this mode.

1. Push the ECON (Economy) button on. (ECON will be displayed.)
 2. Turn the temperature set button to the right or left to set the desired temperature.
- The temperature of the passenger compartment will be maintained automatically. Air flow distribution and fan speed are also controlled automatically.
 - Do not set the temperature lower than the outside air temperature. Otherwise the system may not work properly.
 - Not recommended if windows fog up.

HEATER, AIR CONDITIONER AND AUDIO SYSTEMS

Dehumidified defogging

1. Push the DEF button  on. (The indicator light on the button will come on.)
 2. Turn the temperature set button to the right or left to set the desired temperature.
- To quickly remove ice from the outside of the windows, push the manual fan control button  and set to the maximum position  .
 - As soon as possible after the windshield is cleaned, push the AUTO button to return to the auto mode.
 - When the DEF button  is pushed, the air conditioner will automatically be turned on at outside temperatures above 23°F (-5°C) to defog the windshield, and the air recirculation mode will automatically be turned off.
Outside air is drawn into the passenger

compartment to improve the defogging performance.

MANUAL OPERATION

Fan speed control

Push the fan control button  to manually control the fan speed.

Push the AUTO button to return to automatic control of the fan speed.

Air recirculation





Push the air recirculation button  to recirculate interior air inside the vehicle. The indicator light on the button will come on.

Push it again to make the air inlet controlled automatically (FRESH, REC/FRE and RECIRCULATION). The indicator will go out.

The air recirculation button will not be activated when the air conditioner is in DEF mode.

Air flow control

Pushing the manual air flow control button selects the air outlet to:

- : Air flows from center and side ventilators.
- : Air flows from center and side ventilators and foot outlets.
- : Air flows mainly from foot outlets.
- : Air flows from defroster and foot outlets.

To turn the system off

Push the OFF button.

OPERATING TIPS

When the engine coolant temperature and outside air temperature are low, the air flow from the foot outlets may not operate for a maximum of 150 seconds. However, this is not a malfunction. After the coolant temperature warms up, the air flow

HEATER, AIR CONDITIONER AND AUDIO SYSTEMS

from the foot outlets will operate normally.

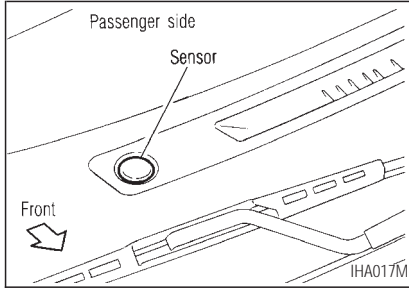

The sensor on the instrument panel helps maintain a constant temperature; do not put anything on or around this sensor.

IN-CABIN MICROFILTER

The air conditioning system is equipped with an in-cabin microfilter which collects dirt, pollen, dust, etc. To make sure air conditioner heats, defogs, and ventilates efficiently, replace the filter in accordance with the maintenance schedule in this manual. To replace

the filter, contact your INFINITI retailer.

The filter should be replaced if air flow decreases significantly or if windows fog up easily when operating the heater or air conditioning system.

SERVICING AIR CONDITIONER

The air conditioning system in your INFINITI vehicle is charged with a new refrigerant designed with the environment in mind. **This new refrigerant will not harm the earth's ozone layer.** However special charging equipment and lubricant are required when servicing your INFINITI air conditioner. Using improper refrigerants or lubricants will cause severe damage to your air conditioning system. See "Capacities and recommended fuel/lubricants" in the "10. Technical and consumer information" section for air conditioning system refrigerant and lubricant recommendations.

Your INFINITI retailer will be able to service

your environmentally friendly air conditioning system.



WARNING

The air conditioner system contains refrigerant under high pressure. To avoid personal injury, any air conditioner service should be done only by an experienced technician with proper equipment.

HEATER, AIR CONDITIONER AND AUDIO SYSTEMS

AUDIO SYSTEM

RADIO

Turn the ignition key to ACC or ON and press the power on switch to turn on the radio. If you listen to the radio with the engine not running, the key should be turned to the ACC position.

Radio reception is affected by station signal strength, distance from radio transmitter, buildings, bridges, mountains and other external influences. Intermittent changes in reception quality normally are caused by these external influences.

Using a cellular phone in or near the vehicle may influence radio reception quality.

Radio reception

Your INFINITI radio system is equipped with state-of-the-art electronic circuits to enhance radio reception. These circuits are designed to

extend reception range, and to enhance the quality of that reception.

However there are some general characteristics of both FM and AM radio signals that can affect radio reception quality in a moving vehicle, even when the finest equipment is used. These characteristics are completely normal in a given reception area, and do not indicate any malfunction in your INFINITI radio system.

Remember that a moving vehicle is not the ideal place to listen to a radio. Because of the movement, reception conditions will constantly change. Buildings, terrain, signal distance and interference from other vehicles can work against ideal reception. Described below are some of the factors that can affect your radio reception.

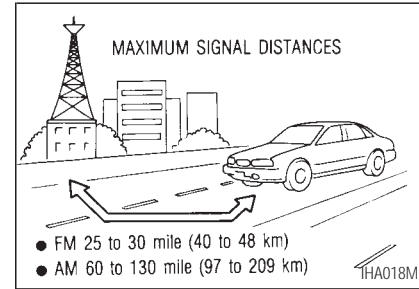

FM RADIO RECEPTION

Range: FM range is normally limited to 25 to 30 miles (40 to 48 km), with monaural (single channel) FM having slightly more range than stereo FM. External influences may sometimes interfere with FM station reception even if the FM station is within 25 miles (40 km). The strength of the FM signal is directly related to the distance between the transmitter and receiver. FM signals follow a line-of-sight path, exhibiting many of the same character-

HEATER, AIR CONDITIONER AND AUDIO SYSTEMS

istics as light. For example they will reflect off objects.

Fade and drift: As your vehicle moves away from a station transmitter, the signals will tend to fade and/or drift.

Static and flutter: During signal interference from buildings, large hills or due to antenna position, usually in conjunction with increased distance from the station transmitter, static or flutter can be heard. This can be reduced by adjusting the treble control counterclockwise to reduce treble response.

Multipath reception: Because of the reflective characteristics of FM signals, direct and reflected signals reach the receiver at the same time. The signals may cancel each other, resulting in momentary flutter or loss of sound.

AM RADIO RECEPTION

AM signals, because of their low frequency, can bend around objects and skip along the

ground. In addition, the signals can be bounced off the ionosphere and bent back to earth. Because of these characteristics, AM signals are also subject to interference as they travel from transmitter to receiver.

Fading: Occurs while the vehicle is passing through freeway underpasses or in areas with many tall buildings. It can also occur for several seconds during ionospheric turbulence, even in areas where no obstacles exist.

Static: Caused by thunderstorms, electrical power lines, electric signs and even traffic lights.

SATELLITE RADIO RECEPTION (if so equipped)

When the satellite radio is first installed or the battery has been replaced, the satellite radio may not work properly. This is not a malfunction. Wait more than 10 minutes with satellite radio ON for satellite radio to receive all of the necessary data.

AUDIO OPERATION PRECAUTIONS

Cassette player

- To maintain good quality sound, INFINITI recommends using cassette tapes of 60 minutes or shorter in length.
- Cassette tapes should be removed from the player when not in use. Store cassettes in their protective cases and away from direct sunlight, heat, dust, moisture and magnetic sources.
- Direct sunlight can cause the cassette to become deformed. The use of deformed cassettes may cause the cassette to jam in the player.
- Do not use cassettes with labels which are peeling and loose. If used, the label could jam in the player.

HEATER, AIR CONDITIONER AND AUDIO SYSTEMS

- If a cassette has loose tape, insert a pencil through one of the cassette hubs and rewind the tape firmly around the hubs. Loose tape may cause tape jamming and wavering sound quality.
- Over a period of time, the playback head, capstan and pinch roller may collect a tape coating residue as the tape is played. This residue accumulation can cause weak or wavering sound, and should be removed periodically with a head cleaning tape. If the residue is not removed periodically, the player may need to be disassembled for cleaning.

Compact Disc (CD) player

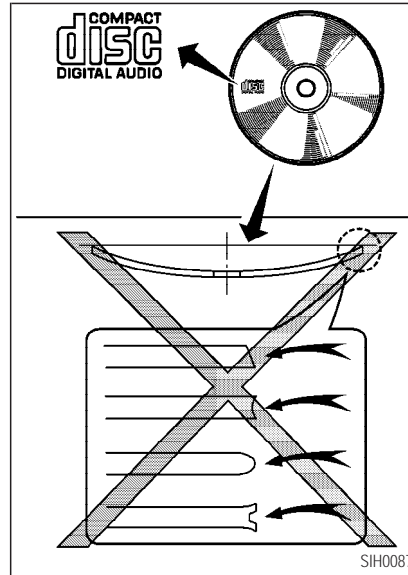

- Only use high quality 4.7 inches (12 cm) round discs that have the "COMPACT disc DIGITAL AUDIO" logo on the disc or packaging.
- During cold weather or rainy days, the player may malfunction due to the humidity. If this occurs, remove the CD and dehumidify or ventilate the player completely.
- The player may skip while driving on rough roads.
- The CD player sometimes cannot function when the compartment temperature is extremely high. Decrease the temperature before use.
- Do not expose the CD to direct sunlight.
- CDs that are of poor quality, dirty, scratched, covered with fingerprints, or that have pin holes may not work properly.

HEATER, AIR CONDITIONER AND AUDIO SYSTEMS

- The following CDs may not work properly:
 - Copy control compact discs (CCCD)
 - Recordable compact discs (CD-R)
 - Rewritable compact discs (CD-RW)
- Do not use the following CDs as they may cause the CD player to malfunction.
 - 3.1 in (8 cm) discs with an adapter
 - CDs that are not round
 - CDs with a paper label
 - CDs that are warped, scratched, or have abnormal edges

HEATER, AIR CONDITIONER AND AUDIO SYSTEMS

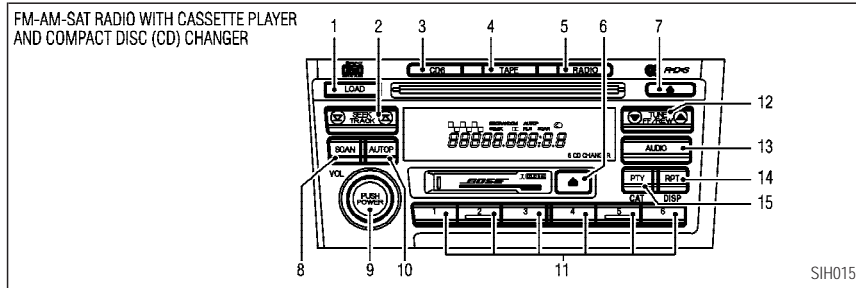

15. PTY (Program type), CAT (Category) button

1. CD LOAD button
2. SEEK/APS REW, APS FF/TRACK CHANGE button
3. CD play button
4. TAPE play button
5. RADIO (Mode) select button
6. TAPE EJECT button
7. CD EJECT button
8. SCAN tuning button
9. ON-OFF/VOLUME control knob
10. AUTOP (Automatic preset) button
11. Station and preset (FM/AM), CD insert or CD play select button
12. RADIO TUNE/FF-REW/AUDIO (Bass, treble, fader, balance, SCV and NR (Dolby)) ADJUSTING button
13. AUDIO (BASS, TREBLE, FADER, BALANCE, SCV and NR (Dolby)) button
14. RPT (repeat) play, DISP (Display) button

HEATER, AIR CONDITIONER AND AUDIO SYSTEMS

FM-AM-SAT RADIO WITH CASSETTE PLAYER AND COMPACT DISC (CD) PLAYER/CD CHANGER

Audio main operation

Head unit

The radio has an FM diversity reception system, which employs two antennas printed on the rear window. This system automatically switches to the antenna which is receiving less interference.

The tape deck employs a permalloy head which allows for improved reproduction of high frequency ranges. Noise is also greatly reduced by the combined use of the Dolby NR (Noise Reduction) system. The auto loudness circuit enhances the low frequency range automatically in both radio reception and tape and CD playback.

ON-OFF/Volume control:

Turn the ignition key to ACC or ON, and then push the ON-OFF/VOL control knob while the system is off to call up the mode (radio, tape or CD) which was playing immediately before the system was turned off. When no CD or tape is loaded, the radio will come on. While the system is on, pushing the ON-OFF/VOL control knob turns the system off.

To turn the radio off, press the ON-OFF/VOL control knob.





Turn the ON-OFF/VOL control knob to adjust the volume.

This vehicle has Speed sensitive Control Volume (SCV) for audio. The audio volume changes as the driving speed changes.

AUDIO button (BASS, TREBLE, FADER, BALANCE, SCV and NR (Dolby):



Press the AUDIO button to change the selecting mode as follows.



BASS → TREBLE → FADER → BALANCE
→ SCV → NR (when cassette playing)
→ BASS

To adjust BASS, Treble, Fader and Balance, press the AUDIO button until the desired mode BASS, TREBLE, FADER or BALANCE appears in the display. Press the TUNE () or () button to adjust Bass and Treble to the desired level. Use the  or  button also to adjust Fader or Balance modes. Fader adjusts the sound level between the front and rear speakers and Balance adjusts the sound between the right and left speakers.

To change the SCV mode to OFF, LOW, MID

HEATER, AIR CONDITIONER AND AUDIO SYSTEMS

or HIGH, press the  or  (TUNE) button (type B only).

To change the NR (Dolby) mode to OFF or ON, press the  or  (TUNE) button while cassette tape is playing. When Dolby is ON, the display indicates the  mark.

Dolby NR is manufactured under license from Dolby Laboratories Licensing Corporation. DOLBY NR and the double-D symbol  are trademarks of Dolby Laboratories Licensing Corporation.

After 10 seconds, the radio or cassette tape display reappears. Once the sound quality is set to the desired level, press the AUDIO button repeatedly until the radio or cassette tape display appears.

FM-AM-SAT (if so equipped) radio operation

 **FM/AM/SAT band select:**

Pushing the RADIO mode band select button

will change the mode as follows:

AM → AM (preset station) → FM1 → FM (preset station) → FM2 → (SAT1 → SAT2 →) AM

If you have not separately contracted for satellite radio or have not had SAT receiver installed, "SAT" will not be shown on the display. Satellite radio hardware must also be installed.

When RADIO mode select button is pushed while the ignition switch is in the ACC or ON position, the radio will come on at the station last played.

The last station played will also come on when the power knob is turned to ON.

If a compact disc or tape is playing when the RADIO mode select button is turned to ON, the compact disc or tape will automatically be turned off and the last radio station played will come on.

The FM stereo indicator ST will glow during FM stereo reception. When the stereo broadcast signal is weak, the radio will automatically change from stereo to monaural reception.



TUNE (Tuning):



WARNING

The radio should not be tuned while driving so full attention may be given to vehicle operation.

Use these buttons for manual tuning. To move quickly through the channels, hold either of the TUNE buttons down for more than 0.5 seconds.



SEEK tuning:



For AM and FM radio

Push the SEEK button  or  , to

HEATER, AIR CONDITIONER AND AUDIO SYSTEMS

tune from high to low or low to high frequencies and stop at the next broadcasting station.

For SATELLITE radio

Push the SEEK button  or  to seek channels of the next or previous category.

SCAN

SCAN tuning:

Push the SCAN tuning button to tune from low to high frequencies and stop at each broadcasting station for 5 seconds. Pushing the button again during this 5 seconds period will stop SCAN tuning and the radio will remain tuned to that station.

If the SCAN tuning button is not pushed within 5 seconds, SCAN tuning moves to the next station.

Display mode (RPT-DISP) of satellite radio:

- Pushing the “RPT” button will display additional information (for example: Title,

Artist name) about the satellite radio broadcast.

- Pushing the “RPT” button for more than 1.5 seconds will change the display mode as follows:

Channel number → Channel name →
Artist name → Song title → Channel
number

Station memory operations:

Twelve stations can be set for the FM band (six for FM1, six for FM2) and satellite radio (six for SAT1, six for SAT2), and six stations can be set for the AM band.

1. Tune to the desired station using the SEEK, SCAN or TUNE button.
2. Select the desired station and keep pushing any of the desired station memory buttons (1 to 6) until a beep sound is heard. (The radio mutes when the select button is pushed.)

3. The channel indicator will then come on and the sound will resume. Memorizing is now complete.

4. Other buttons can be set in the same manner.

If the battery cable is disconnected, or if the fuse blows, the radio memory will be cancelled. In that case, reset the desired stations.

AUTOP

(Automatic preset) button:

To select the preset FM, AM, SAT or PTY station/channel, push the AUTOP button for less than 1.5 seconds.

To preset the FM, AM, SAT or PTY station, push the AUTOP button for more than 1.5 seconds.

Radio data system (RDS)

RDS stands for Radio Data System, and is a data information service transmitted by some radio stations on the FM band (not AM band) and/or SATELLITE band encoded within a

HEATER, AIR CONDITIONER AND AUDIO SYSTEMS

regular radio broadcast. Currently, most RDS stations are in large cities, but many stations are now considering broadcasting RDS data.

RDS can display:

- Station call sign, such as “WHFR 98.3”.
- Station name, such as “The Groove”.
- Music or programming type such as “Classical”, “Country”, or “Rock”.
- Traffic reports about delays or construction.



If the station broadcasts RDS information, the RDS icon is displayed.

PTY Program type (Category (CAT)) button:

When PTY button is pressed during FM mode, the PTY name of the current tuned station is displayed. When the PTY (CAT) button is pressed during satellite radio mode, the category name of the current channel is displayed.

During this time if the PTY data code is zero, or the data is unreadable; the display will show NONE.

1. PTY (CAT) selection mode

PTY (CAT) name selection can be done by the up/down TUNE button  or  in the PTY (CAT) selection mode.



After selecting a PTY (CAT) name, push the SEEK button or SCAN button within 10 seconds. Tuning to the PTY (CAT) station will start. If you do not push the TUNE button within the 10 second period, the PTY (CAT) mode will be canceled.

PTY (CAT) name selection can also be achieved by pressing the preset buttons.

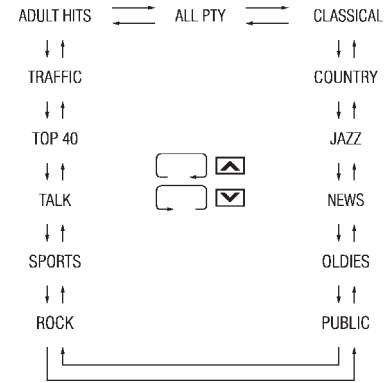
Initial PTY (CAT) names are stored in the preset buttons; but these can be changed by pressing the preset buttons for more than 1.5 seconds when the desired PTY name is in the display.



2. PTY (CAT) SEEK tuning

After selecting a PTY (CAT) name, push the SEEK button  or  within 10 seconds. Tuning to the PTY (CAT) station will start. If you do not push the SEEK button within the 10 second period, the PTY (CAT) mode will be canceled.

HEATER, AIR CONDITIONER AND AUDIO SYSTEMS

3. PTY (CAT) SCAN tuning mode

Push the SCAN tuning button to tune the PTY (CAT) name station, and stop at each broadcasting station for 5 seconds. Pushing the button again during this 5 second period will stop SCAN tuning and the radio will remain tuned to that station. If the SCAN tuning button is not pushed within 5 seconds, SCAN tuning moves to the next station.

Cassette tape player operation

Turn the ignition key to ACC or ON, and then lightly insert the cassette tape into the tape door. The cassette tape will be automatically pulled into the player.

The radio or CD will turn off (if it is on) and the cassette tape will begin to play.



CAUTION

Do not force the cassette tape into the tape door. This could cause player damage.

If the system is turned off by pushing the ON-OFF/VOL control knob with the cassette tape still in the player, the tape will resume playing when the system is turned back on.





TAPE PLAY:

- When the TAPE button is pushed with the system turned off and a tape loaded, the system will come on and the tape will play.
- When the TAPE button is pushed with either the radio or compact disc turned on and the tape loaded, the compact disc or the radio will automatically be turned off and the tape will play.

- When the TAPE button is pushed with the TAPE playing, the tape will play the program recorded on the reverse side.





**FF (Fast Forward),
REW (Rewind):**

Push the  (fast forward) button to fast forward the tape. To rewind the tape, push the  (rewind) button. Either the FF or REW symbol illuminates on the right side of the display window. To stop the FF or REW function, press the  (fast forward) or  (rewind) again, or the TAPE button.





**APS (Automatic
Program Search)
FF, APS REW:**

When the  (APS FF) button is pushed while the tape is being played, the next program will start to play from the beginning. Push the  (APS REW) button several times to skip through programs. The tape will advance the number of times the button is

HEATER, AIR CONDITIONER AND AUDIO SYSTEMS

pushed (up to nine programs).

When the  (APS REW) button is pushed once, the program being played starts over from the beginning. Push the  (APS REW) button several times to skip back several selections. The tape will go back the number of times the button is pushed. Either the FF or REW symbol flashes on the right side of the display window while searching for the selection.

This system searches for the blank intervals between selections. If there is a blank interval within one program or there is no interval between programs, the system may not stop in the desired or expected location.

SCAN tuning:

Push the SCAN tuning button while playing a tape, it stops at the next tape program for 5 seconds. Pushing the button again during this 5 second period will stop SCAN tuning and the tape program is continued. If the SCAN

tuning button is not pushed within 5 seconds, SCAN tuning moves to the next tape program.

TAPE EJECT:

When this button is pushed with the tape loaded, the tape will be ejected.

When the tape is ejected while it is being played, the system will be turned off.

Compact disc (CD) changer operation

Turn the ignition key to the ACC or ON position and insert the compact disc into the slot with the label side facing up. The compact disc will be guided automatically into the slot and start playing.

After loading the disc, the number of tracks on the disc and the play time will appear on the display.

If the radio or tape is already operating, it will automatically turn off and the compact disc will play.



CAUTION

Do not force the compact disc into the slot. This could damage the player.

If the system has been turned off while the compact disc was playing, pushing the ON-OFF/VOL control knob will start the compact disc.

button:

To insert a CD in the CD changer, push the LOAD button for less than 1.5 seconds. Select the loading slot by pushing the CD insert select button (1 to 6), then insert the CD.

To insert 6 CDs to the CD changer, push the LOAD button for more than 1.5 seconds.

The inserted slot numbers will illuminate on the display.

HEATER, AIR CONDITIONER AND AUDIO SYSTEMS



CD6 PLAY:

When the CD6 button is pushed with the system off and the compact disc loaded, the system will turn on and the compact disc will start to play.

When the CD6 button is pushed with the compact disc loaded with the tape or the radio playing, the tape or radio will automatically be turned off and the compact disc will start to play.





FF (Fast Forward), REW (Rewind):

When the  (fast forward) or  (rewind) button is pushed while the compact disc is being played, the compact disc will play while fast forwarding or rewinding. When the button is released, the compact disc will return to normal play speed.



APS (Automatic Program Search) FF, APS REW:

When the  (APS FF) button is pushed while the compact disc is being played, the program next to the present one will start to play from its beginning. Push several times to skip through programs. The compact disc will advance the number of times the button is pushed. (When the last program on the compact disc is skipped through, the first program will be played.) When the  (APS REW) button is pushed, the program being played returns to its beginning. Push several times to skip back through programs. The compact disc will go back the number of times the button is pushed.

CD PLAY button:

To change CD, push the CD play select button (1 to 6).

SCAN SCAN tuning:

When the SCAN tuning button is pushed for less than 1.5 seconds while the CD is being played, the beginning of all the CD programs in each track will be played for 10 seconds in sequence.

When the SCAN tuning button is pushed for more than 1.5 seconds while the CD is being played, the first program in all the CDs will be played for 10 seconds.

Pushing the button again during this 10 second period will stop SCAN tuning.

If the SCAN tuning button is not pushed within 10 seconds, SCAN tuning moves to the next disc program.

RPT REPEAT (RPT):

When the RPT button is pushed while the compact disc is played, the play pattern can be changed as follows:

HEATER, AIR CONDITIONER AND AUDIO SYSTEMS



DISPLAY CD TEXT:

To indicate the CD mode text, push the PTY button during CD playing.

To change the indicated text, push PTY button.

The text will change as follows:



If the text is more than 10 letters, push the AUTOP button to display the remaining text.



CD EJECT:

When the CD EJECT button is pushed with the compact disc loaded, the compact disc will be ejected.

To eject the discs selected by the EJECT button, push it for less than 1.5 seconds.

To eject all the discs, push the EJECT button for more than 1.5 seconds.

When this button is pushed while the compact disc is being played, the compact disc will come out and the system will turn off.

If the compact disc comes out and is not removed, it will be pulled back into the slot to protect it. (without 8 cm diameter compact discs)

CD IN indicator:

CD IN indicator appears on the display when the CD is loaded with the system on.

HEATER, AIR CONDITIONER AND AUDIO SYSTEMS

FM-AM-SAT RADIO WITH CASSETTE PLAYER

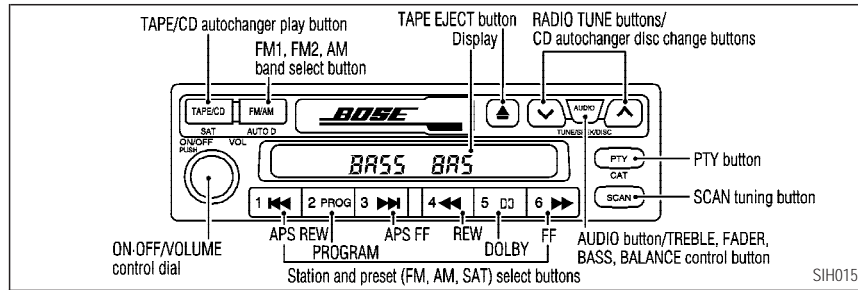

Refer to the separate Owner's Manual for information about the navigation system.

Audio main operation

ON-OFF/Volume control:

Turn the ignition key to ACC or ON, then push the ON-OFF/Volume control knob. The mode (radio or cassette) which was playing immediately before the system was turned off resumes playing. When no cassette is loaded,

the radio comes on. Pushing the ON-OFF/Volume control knob again turns the system off.

Turn the ON-OFF/Volume control knob to adjust the volume.

This vehicle has Speed sensitive Control Volume (SCV) for audio. The audio volume changes as the driving speed changes.

AUDIO button (BASS, TREBLE, FADER, BALANCE, SCV, DISP MODE):

Press the AUDIO button to change the selecting mode as follows:

Temp Artist Display → Temp Title Display → BASS → TREBLE → FADER → BALANCE → SCV → DISP MODE → MENU OFF.



When the AUDIO button is pushed while listening to the satellite radio, the artist name and song title will be displayed temporarily.



To adjust Bass, Treble, Fader, Balance, press the AUDIO button until the desired mode BASS, TREBLE, FADER or BALANCE appears in the display.

Press the ∇ or \blacktriangle button to adjust Bass and Treble to the desired level. Use the ∇ or \blacktriangle button to adjust Fader or Balance modes. Fader adjusts the sound level between the front and rear speakers and Balance adjusts the sound level between the

HEATER, AIR CONDITIONER AND AUDIO SYSTEMS

right and left speakers.

To change the SCV mode to OFF, LOW, MID or HIGH, press the  or  (TUNE) button.

When the DISP MODE is selected while playing the satellite radio, you can display the following information in sequence by using the  or  button.

CH Number → CH Name → Artist name → Song title

After 10 seconds, the radio or cassette tape display reappears. Once the sound quality is set to the desired level, press the AUDIO button repeatedly until the radio or cassette tape display appears.

Radio/Cassette tape priority mode

In this mode, the radio station illuminates in the display during radio operation. During

cassette tape operation, TAPE illuminates in the display.

FM-AM radio operation

 **FM-AM band select:**

Pushing the FM-AM band select button will change the band as follows:

AM → AM (preset station) → FM1 → FM2
→ FM (preset station) → AM

When FM/AM band select button is pushed while the ignition switch is in the ACC or ON, the radio will come on at the station last played.

The last station played will also come on when the power knob is turned to ON.

If a compact disc or tape is playing when the FM/AM band select button is turned to ON, the compact disc or tape will automatically be turned off and the last radio station played will come on.

To preset (AUTO.P) the AM or FM station, push the FM/AM button for more than 1.5 seconds.

The FM stereo indicator ST illuminates during FM stereo reception. When the stereo broadcast signal is weak, the radio automatically changes from stereo to monaural reception.



TUNE (Tuning):



WARNING

The radio should not be tuned while driving so full attention may be given to vehicle operation.

Use these buttons for manual tuning. To move quickly through the channels, hold either of the TUNE buttons down for more than 0.5 seconds.

HEATER, AIR CONDITIONER AND AUDIO SYSTEMS

SCAN tuning:



Push the SCAN tuning button and SCAN will illuminate in the display window. SCAN tuning begins from high to low or low to high frequencies and stops at each broadcasting station for 5 seconds. Pushing the button again during this 5 second period stops SCAN tuning and the radio remains tuned to that station.



If any of the SEEK/SCAN tuning buttons are not pushed within 5 seconds, SCAN tuning moves to the next station.

PTY Program type (Category (CAT)) button:

When PTY button is pressed during FM mode, the PTY name of the current tuned station is displayed. During this time if the PTY data code is zero, or the data is unreadable; the display will show NONE.

1. PTY (CAT) selection mode

PTY (CAT) name selection can be done by the up/down TUNE button  or  in the PTY (CAT) selection mode.



It is possible to shift the PTY (CAT) name by one step, with one push of the up/down tuning button  or .

PTY (CAT) name selection can also be achieved by pressing the preset buttons.

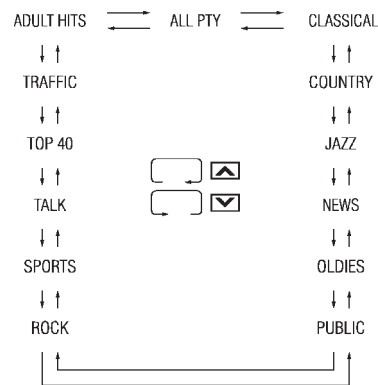
Initial PTY (CAT) names are stored in the preset buttons; but these can be changed by pressing the preset buttons for more than 1.5 seconds when the desired PTY (CAT) name is in the display.



2. PTY (CAT) SEEK tuning

After selecting a PTY (CAT) name, push the TUNE button  or  for more than 1.5 seconds within 10 seconds. Tuning to the PTY (CAT) station will start. If you do not push the TUNE button within the 10 second period, the PTY mode will be canceled.

HEATER, AIR CONDITIONER AND AUDIO SYSTEMS

3. PTY (CAT) SCAN tuning mode

Push the SCAN tuning button to tune the PTY name station, and stop at each broadcasting station for 5 seconds. Pushing the button again during this 5 second period will stop SCAN tuning and the radio will remain tuned to that station. If the SCAN tuning button is not pushed within 5 seconds, SCAN tuning moves to the next station.

Satellite radio operation (if so equipped)

TAPE/CD Satellite channel (SAT1 or SAT2) selected tape/CD play:



Pushing the TAPE/CD button will change the mode as follows:

TAPE → CD → (SAT1 → SAT2 →) TAPE





If you have not separately contracted for satellite radio, "SAT1 and SAT2" will not be shown on the display. Satellite radio hardware

must also be installed.



Press the  or  button to select the satellite radio channel. Channels which are not available will automatically be skipped. If channel 0 is selected, it will display the hardware ID of the satellite tuner.

SEEK/SCAN tuning:

1. When the PTY button is pushed while the satellite radio is ON, the Category mode will be displayed.
2. Push the ,  or PTY (up only) button to select the Category.
3. Push and hold the  or  button to seek the channel in the selected category.
4. If the SCAN button is pushed after operation 1 or 2, scan will stop at each channel in the selected category for 5 seconds.

To cancel the scan tuning, press the SCAN button.

Station memory (and preset) operations

Twelve stations can be set for the FM band (six for FM1, six for FM2), SAT band (six for SAT1, six for SAT2) and six stations can be set for the AM band.

1. Tune to the desired station using the SCAN or TUNE buttons.
2. Select the desired station and keep pushing any of the desired station memory buttons (1 to 6) until a beep sound is heard. (The radio mutes when the select button is pushed.)
3. The channel indicator will come on and the sound will resume. Memorizing is now complete.
4. Other station select buttons can be set in the same manner.

HEATER, AIR CONDITIONER AND AUDIO SYSTEMS

If the battery cable is disconnected, or if the radio fuse opens, the radio memory is cancelled. In that case, reset the desired stations.

Cassette tape player operation

Turn the ignition key to ACC or ON, then carefully insert a cassette tape into the tape door.

The cassette tape automatically pulls into the player. The word TAPE and moving digital squares illuminate on the right side of the display window.



CAUTION

Do not force the cassette tape into the tape door. This could cause player damage.

The cassette tape automatically changes directions to play the other side when the first side is complete. At this time, the moving

digital squares illuminate on the left side of the display window.

TAPE/CD PLAY:

When the TAPE/CD button is pushed with the radio turned on and the tape loaded, the radio will automatically be turned off and the tape will play.

If the TAPE/CD button is pushed during either the FF, REW, APS FF or APS REW function, the cassette tape enters the normal play mode.

When the TAPE/CD button is pushed with the CD playing, the tape will play.

4 ◀◀ 6 ▶▶ FF (fast forward), REW (rewind):

Push either the FF or REW button for the desired direction.

The FF or REW symbol illuminates in the display.

To stop the FF or REW function, press the FF

or REW button again, or the TAPE/CD button.

1 |◀◀ 3 ▶▶| APS (automatic program search) FF, APS REW:

Push either the APS FF or APS REW button while the cassette tape is playing. The tape runs quickly, stops, then plays the next selection. Either the FF or REW symbol flashes in the display while searching for the selection.

This system searches for the blank intervals between selections. If there is a blank interval within one selection or there is no interval between selections, the system may not stop in the desired or expected location.

2 PRO PROG (program):

Push the PROG button. The moving digital squares illuminate on either the right or left side of the display window to indicate the side of program play.

HEATER, AIR CONDITIONER AND AUDIO SYSTEMS

If the PROG button is pushed during either the FF or REW function the tape enters the normal play mode.

Dolby NR (Noise Reduction):

Push the Dolby NR  button for Dolby NR encoded tapes to reduce high frequency tape noise. The  indicator light comes on.

Dolby NR is manufactured under license from Dolby Laboratories Licensing Corporation. DOLBY NR and the double-D symbol  are trademarks of Dolby Laboratories Licensing Corporation.

Metal or chrome tape usage:

The cassette player is automatically set to high performance play when playing a metal or chrome cassette tape.

TAPE EJECT:

Push the EJECT button. The cassette tape automatically comes out.

Compact disc (CD) player/changer operation

Turn the ignition key to the ACC or ON position.

To play the CD, push the TAPE/CD button after loading the disc.

With the disc loaded, the number of discs and tracks will appear on the display.

If the radio or tape is already operating, it will automatically turn off and the CD will play.

CAUTION

Do not force the CD into the slot. This could damage the player.

If the system has been turned off while the CD was playing, pushing the ON-OFF/VOL control knob will start the CD.

PLAY:

- When the TAPE/CD button is pushed with the CD loaded in the player or CD autochanger (if so equipped):
 - a) If the TAPE player (if cassette tape is inserted) is turned on, the mode (CD player or CD autochanger) will turn on.
 - b) If the CD player is on, the CD player will automatically be turned off and the CD autochanger will turn on.
 - c) If the CD autochanger is on, the CD autochanger will automatically be turned off and the TAPE player will turn on.
- When the TAPE/CD button is pushed with the CD loaded in only the CD autochanger, the CD autochanger will turn on.
- When the TAPE/CD button is pushed with no disc in either the player or CD au-



HEATER, AIR CONDITIONER AND AUDIO SYSTEMS



tochanger, the TAPE player will change the tape side.

  **DISC change:**

Use these buttons for selecting the compact disc inserted into the CD magazine.

  **FF (Fast Forward),
REW (Rewind):**

When the  (fast forward) or  (rewind) button is pushed while the CD is being played, the CD will play while fast forwarding or rewinding. When the button is released, the CD will return to normal play speed.

  **APS (Automatic Program Search) FF, APS
REW:**

When the  (APS FF) button is pushed while the CD is being played, the program next to the present one will start to play from its beginning. Push several times to skip through programs. The CD will advance the

number of times the button is pushed. (When the last program on the CD is skipped through, the first program will be played.) When the  (APS REW) button is pushed, the program being played returns to its beginning. Push several times to skip back through programs. The CD disc will go back the number of times the button is pushed.

 **PROG (Program):**

When the PROG button is pushed while the CD is being played, the play pattern will change as follows:

ALL → 1 → RANDOM → OFF → ALL

ALL: All the programs will be played repeatedly in sequence.

1: Only one program (the one being played when the PROG button is pushed) will be repeated.

RANDOM: Programs will be played at random, not following the sequence on the CD. To

change the one disc random or all disc random, push the PROG button for a second. The same program may be repeated twice.

When the CD is ejected, the play pattern will automatically change to all.

 **CD EJECT:**

When the CD EJECT button is pushed with the CD loaded, the CD will be ejected.

When this button is pushed while the CD is being played, the CD will come out and the system will turn off.

If the CD comes out and is not removed, it will be pulled back into the slot to protect it. (except 8 cm diameter compact discs)

CD IN indicator:

CD IN indicator appears on the display when the CD is loaded with the system on.

HEATER, AIR CONDITIONER AND AUDIO SYSTEMS

CD CARE AND CLEANING

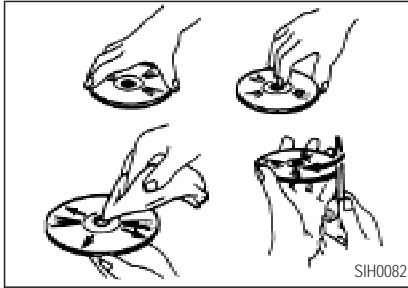

- Handle a CD by its edges. Never touch the surface of the disc. Do not bend the disc.
- Always place the discs in the storage case when they are not being used.
- To clean a disc, wipe the surface from the center to the outer edge using a clean, soft cloth. Do not wipe the disc using a circular motion.
Do not use a conventional record cleaner or alcohol intended for industrial use.

- A new disc may be rough on its inner and outer edges. Remove the rough edges using the side of a pen or pencil as illustrated.

STEERING WHEEL SWITCH FOR AUDIO CONTROL (if so equipped)

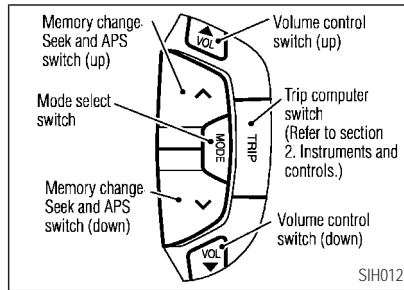

The audio system can be operated using the controls on the steering wheel.

MODE select switch

Push the mode select switch to change the

mode in the sequence of AM, FM1, FM2, (SAT1, SAT2 — if so equipped) CD, CD autochanger (if so equipped) and Tape.

Volume control switches

Push the upper side switch or lower side switch to adjust the volume.



Upper side: Volume increases

Lower side: Volume decreases





Tuning

Memory change (radio):

Push the tuning switch  or  for less than 1.5 seconds to change the radio frequency, or SAT radio preset channel.

SEEK tuning (radio):

Push the tuning switch  or  for more than 1.5 seconds to seek the next or previous radio station, or for a cursory search of satellite radio.

HEATER, AIR CONDITIONER AND AUDIO SYSTEMS

APS (Automatic Program Search) FF, APS REW (tape/CD):

Push the tuning switch  for less than 1.5 seconds while the tape/CD is being played, the next program will start to play from the beginning.

Push the  switch several times to skip through programs. The tape/CD will advance the number of times the switch is pushed (up to nine programs).



Push the tuning switch  for less than 1.5 seconds and, the program being played starts over from the beginning.



Push the  switch several times to skip back several selections. The tape/CD will go back the number of times the switch is pushed. Either the FF or REW symbol flashes on the right side of the display window while searching for the selection.

This system searches for the blank intervals between selections. If there is a blank interval

within one program or there is no interval between programs, the system may not stop in the desired or expected location.

FF (Fast Forward), REW (Rewind) (tape):

Push the tuning button  for more than 1.5 seconds to fast forward the tape. To rewind the tape, push the tuning button  for more than 1.5 seconds. Either the FF or REW symbol illuminates on the right side of the display window.

To stop the FF or REW function, press the  or  button again for more than 1.5 seconds.

ANTENNA

Window antenna

The antenna pattern is printed inside the rear window.



CAUTION

- *Do not place metalized film near the rear window glass or attach any metal parts to it. This may cause poor reception or noise.*
- *When cleaning the inside of the rear window, be careful not to scratch or damage the rear window antenna. Lightly wipe along the antenna with a dampened soft cloth.*

HEATER, AIR CONDITIONER AND AUDIO SYSTEMS

COMPACT DISC (CD) AU-TOCHANGER (if so equipped)

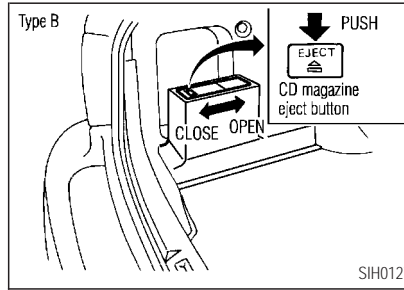
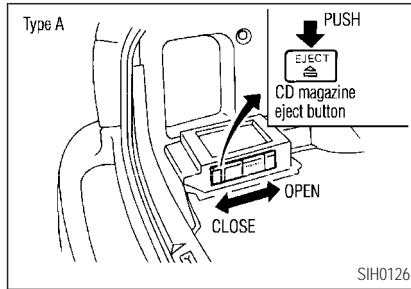

CD magazine

Insert the CD magazine into the changer with the label side facing up, as illustrated. Close the sliding lid of the CD autochanger.

When ejecting the CD magazine, press the  EJECT button located inside the CD autochanger.

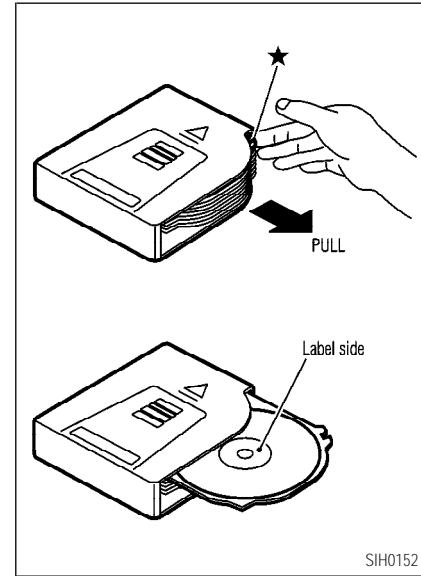

Disc loading

- Pull the disc holder from the magazine and turn over the magazine.

HEATER, AIR CONDITIONER AND AUDIO SYSTEMS

- Insert the CD with label side facing up then push the disc holder into the magazine.

Disc removal

- Pull the * marked area with your fingers.
- Use your fingertips to grasp the center part of the disc and remove the disc.



CAUTION

- *Do not touch the playing surface of the disc.*
- *Do not use 8 cm discs. They may cause player damage even if using with the optional adapter.*

CAR PHONE OR CB RADIO

When installing a CB radio or a car phone in your INFINITI, be sure to observe the following cautions, otherwise the new equipment may adversely affect the Engine Control sys-

tem and other electronic parts.



WARNING

- *A cellular telephone should not be used while driving so full attention may be given to vehicle operation. Some jurisdictions prohibit the use of cellular telephones while driving.*
- *If you must make a call while your vehicle is in motion, the hands free cellular phone operational mode (if so equipped) is highly recommended. Exercise extreme caution at all times so full attention may be given to vehicle operation.*
- *If a conversation in a moving vehicle requires you to take*

notes, pull off the road to a safe location and stop your vehicle before doing so.



CAUTION

- *Keep the antenna as far as possible away from the Electronic Control Unit (including radio) under the center of the instrument panel.*
- *Keep the antenna wire more than 8 in (20 cm) away from the Engine Control harness. Do not route the antenna wire next to any harness.*
- *Adjust the antenna standing-wave ratio as recommended by the manufacturer.*

HEATER, AIR CONDITIONER AND AUDIO SYSTEMS

- *Connect the ground wire from the CB radio chassis to the body.*
- *For details, consult your INFINITI retailer.*

5 STARTING AND DRIVING

Precautions when starting and driving	5-2	Parking/parking on hills.....	5-15
Exhaust gas (Carbon monoxide).....	5-2	Power steering.....	5-16
Three way catalyst	5-3	Brake system	5-16
Avoiding collision and rollover.....	5-4	Braking precautions.....	5-16
Drinking alcohol/drugs and driving.....	5-4	Anti-lock brake system (ABS).....	5-17
Ignition switch.....	5-5	Traction control system	
Automatic transmission	5-5	(if so equipped).....	5-19
Key positions.....	5-6	Vehicle dynamic control system (VDC) (if so	
Infiniti Vehicle Immobilizer System.....	5-6	equipped)	5-20
Before starting the engine.....	5-7	Cold weather driving	5-21
Starting the engine.....	5-7	Freeing a frozen door lock	5-21
Driving the vehicle.....	5-8	Anti-freeze	5-21
Automatic transmission	5-8	Battery	5-21
Parking brake.....	5-11	Draining of coolant water	5-21
Cruise control	5-12	Tire equipment	5-21
Precautions on cruise control	5-12	Special winter equipment.....	5-22
Cruise control operations.....	5-13	Driving on snow or ice	5-22
Break-in schedule	5-14	Engine block heater (if so equipped)...	5-23
Increasing fuel economy	5-14		

STARTING AND DRIVING

PRECAUTIONS WHEN STARTING AND DRIVING



WARNING

- Do not leave children or adults who would normally require the support of others alone in your vehicle. Pets should not be left alone either. They could accidentally injure themselves or others through inadvertent operation of the vehicle. Also, on hot, sunny days, temperatures in a closed vehicle could quickly become high enough to cause severe or possibly fatal injuries to people or animals.
- Closely supervise children when they are around cars to prevent them from playing and becoming locked in the trunk where they

could be seriously injured. Keep the car locked, with the trunk closed, when not in use, and prevent children's access to car keys.

EXHAUST GAS (Carbon monoxide)



WARNING

Do not breathe exhaust gases; they contain colorless and odorless carbon monoxide. Carbon monoxide is dangerous. It can cause unconsciousness or death.

- If you suspect that exhaust fumes are entering the vehicle, drive with all windows fully open, and have the vehicle inspected immediately.

- Do not run the engine in closed spaces such as a garage.
- Do not park the vehicle with the engine running for any extended length of time.
- Keep the trunk lid, closed while driving, otherwise exhaust gases could be drawn into the passenger compartment. If you must drive with the trunk lid open, follow these precautions.
 1. Open all the windows.
 2. Set the air recirculation switch OFF and the fan control at 4 (high) to circulate the air.
- If electrical wiring or other cable connections must pass to a trailer through the seal on the trunk lid

or the body, follow the manufacturer's recommendation to prevent carbon monoxide entry into the vehicle.

- If a special body or other equipment is added for recreational or other usage, follow the manufacturer's recommendation to prevent carbon monoxide entry into the vehicle. (Some recreational vehicle appliances such as stoves, refrigerator, heaters, etc. may also generate carbon monoxide.)
- The exhaust system and body should be inspected by a qualified mechanic whenever:
 - a. The vehicle is raised for service.
 - b. You suspect that exhaust

fumes are entering into the passenger compartment.

- c. You notice a change in the sound of the exhaust system.
- d. You have had an accident involving damage to the exhaust system, underbody, or rear of the vehicle.

THREE WAY CATALYST

The three way catalyst is an emission control device installed in the exhaust system. Exhaust gases in the converter are burned at high temperatures to help reduce pollutants.



WARNING

- The exhaust gas and the exhaust system are very hot. Keep people,

STARTING AND DRIVING

animals or flammable materials away from the exhaust system components.

- Do not stop or park the vehicle over flammable materials such as dry grass, waste paper or rags. They may ignite and cause a fire.



CAUTION

- Do not use leaded gasoline. Deposits from leaded gasoline seriously reduce the three way catalyst's ability to help reduce exhaust pollutants.
- Keep your engine tuned up. Malfunctions in the ignition, fuel injection, or electrical systems can cause overrich fuel flow into the

STARTING AND DRIVING

three way catalyst, causing it to overheat. Do not keep driving if the engine misfires, or if noticeable loss of performance or other unusual operating conditions are detected. Have the vehicle inspected promptly by an authorized INFINITI retailer.

- *Avoid driving with an extremely low fuel level. Running out of fuel could cause the engine to misfire, damaging the three way catalyst.*
- *Do not race the engine while warming it up.*
- *Do not push or tow your vehicle to start the engine.*

AVOIDING COLLISION AND ROLLOVER



WARNING

Failure to operate this vehicle in a safe and prudent manner may result in loss of control or an accident.

Be alert and drive defensively at all times. Obey all traffic regulations. Avoid excessive speed, high speed cornering, or sudden steering maneuvers, because these driving practices could cause you to lose control of your vehicle. **As with any vehicle, a loss of control could result in a collision with other vehicles or objects, or cause the vehicle to rollover, particularly if the loss of control causes the vehicle to slide sideways.** Be attentive at all times, and avoid driving when tired. Never drive when under the influence of alcohol or drugs (including prescription or over-the-counter

drugs which may cause drowsiness). Always wear your seat belt. See "Seat Belts" in the "1. Seats, restraints and supplemental air bag systems" section. Also instruct your passengers to do so.

DRINKING ALCOHOL/ DRUGS AND DRIVING



WARNING

Never drive under the influence of alcohol or drugs. Alcohol in the bloodstream reduces coordination, delays reaction time and impairs judgement. Driving after drinking alcohol increases the likelihood of being involved in an accident injuring yourself and others. Additionally, if you are injured in the accident, alcohol can increase the severity of the injury.

INFINITI is committed to safe driving. You must not drive under the influence of alcohol. Every year thousands of people are injured or killed in alcohol related accidents. Although the local laws vary on what is considered to be legally intoxicated, the fact is that alcohol affects all people differently and most people underestimate the effects of alcohol.

Remember, drinking and driving don't mix!

And that's true for drugs too (over the counter, prescription, and illegal drugs). Don't drive if your ability to operate your vehicle is impaired by alcohol, drugs, or some other physical condition.

IGNITION SWITCH



WARNING

Never remove or turn the key to the

LOCK position while driving. The steering wheel will lock. This may cause the driver to lose control of the vehicle and could result in serious vehicle damage and/or personal injury.

AUTOMATIC TRANSMISSION

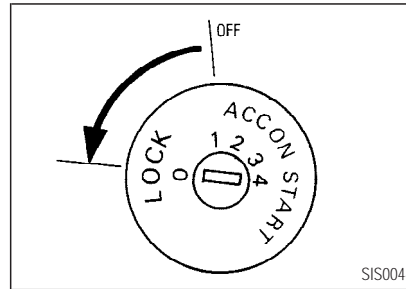

The ignition lock is designed so that the key cannot be turned to LOCK and removed until

STARTING AND DRIVING

the selector lever is moved to the P (Park) position.

When removing the key from the ignition, make sure the selector lever is in the P (Park) position.

If the selector lever is not returned to the P (Park) position, the key cannot be moved toward LOCK.

When the key cannot be turned toward the LOCK position, proceed as follows to remove the key:

1. Move the selector lever into the P (Park) position.
2. Turn the ignition key slightly in the ON direction.
3. Turn the key toward the LOCK position.
4. Remove the key.

If the key is removed from the ignition switch, the selector lever cannot be moved from the P

STARTING AND DRIVING

(Park) position. **The selector lever can be moved if the ignition switch is in the ON position and the foot brake pedal is depressed.**

There is an OFF position in between LOCK and ACC, although it does not show on the lock cylinder. When the ignition is in OFF the steering wheel is not locked.

In order for the steering wheel to be locked, it must be turned about 1/6 of a turn counter-clockwise from the straight up position.

To lock the steering wheel, turn the key to the LOCK position. Remove the key. To unlock the steering wheel, insert the key and turn it gently while rotating the steering wheel slightly right and left.

KEY POSITIONS

The switch includes an anti-theft steering lock device.

LOCK (Normal parking position) (0)

The ignition key can only be removed when the switch is in this position.

OFF (1)

The engine can be turned off without locking the steering wheel.

ACC (Accessories) (2)

This position activates electrical accessories such as the radio when the engine is not running.

ON (Normal operating position) (3)

This position turns on the ignition system and the electrical accessories.

START (4)

This position activates the starter motor, starting the engine.

INFINITI VEHICLE IMMOBILIZER SYSTEM

The Infiniti Vehicle Immobilizer System will

not allow the engine to start without the use of the registered Infiniti Vehicle Immobilizer System key.

If the engine fails to start using the registered Infiniti Vehicle Immobilizer System key (it may be due to interference caused by another Infiniti Vehicle Immobilizer System key, an automated toll road device or automated payment device on the key ring). Restart the engine using the following procedures:

1. Leave the ignition switch in the ON position for approximately 5 seconds.
2. Turn ignition switch to the OFF or LOCK position and wait approximately 10 seconds.
3. Repeat step 1 and 2 again.
4. Restart the engine while holding the device (which may have caused the interference) separate from the registered Infiniti Vehicle Immobilizer System key.

If this procedure allows the engine to start, INFINITI recommends placing the registered Infiniti Vehicle Immobilizer System key on a separate key ring to avoid interference from other devices.

BEFORE STARTING THE ENGINE

- Make sure the area around the vehicle is clear.
- Maintenance items listed here should be checked periodically, e.g., each time you check engine oil.
- Check that all windows and lights are clean.
- Visually inspect tires for their appearance and condition. Also, check tires for proper inflation.
- Lock all doors.
- Position seat and adjust head restraints.

- Adjust inside and outside mirrors.
- Fasten seat belts and ask all passengers to do likewise.
- Check the operation of warning lights when key is turned to the ON (3) position.

STARTING THE ENGINE

1. Apply the parking brake.
2. Move the selector lever to P (Park) or N (Neutral). (P preferred.)

The starter is designed not to operate if the selector lever is in one of the driving positions.

3. Crank the engine **with your foot off the accelerator pedal** by turning the ignition key to START. Release the key when the engine starts. If the engine starts, but fails to run, repeat the above procedure.
- If the engine is very hard to start in extremely cold weather after a very short

STARTING AND DRIVING

running time, depress the accelerator pedal a little (approximately 1/5 to the floor) and hold it then crank the engine. Release the key and the accelerator pedal when the engine starts.

- If the engine is very hard to start because it is flooded, depress the accelerator pedal all the way to the floor and hold it. Crank the engine for 5 to 6 seconds. After cranking the engine, release the accelerator pedal. Crank the engine with your foot off the accelerator pedal by turning the ignition key to START. Release the key when the engine starts. If the engine starts, but fails to run, repeat the above procedure.



CAUTION

Do not operate the starter for more than 10 seconds at a time. If the en-

STARTING AND DRIVING

gine does not start, turn the key off and wait 10 seconds before cranking again, otherwise the starter could be damaged.

4. Warm-up

Allow the engine to idle for at least 30 seconds after starting. Drive at moderate speed for a short distance first, especially in cold weather.

DRIVING THE VEHICLE AUTOMATIC TRANSMISSION

Gate type shift

The automatic transmission in your vehicle is electronically controlled by a transmission control module to produce maximum power and smooth operation.

Shown on the following pages are the recommended operating procedures for this trans-

mission. Follow these procedures for maximum vehicle performance and driving enjoyment.

Starting the vehicle

After starting the engine, fully depress the foot brake pedal before shifting the selector lever to the R, N, D, 3, 2 or 1 position. Be sure the vehicle is fully stopped before attempting to shift the selector lever.

This automatic transmission is designed so the foot brake pedal must be depressed before shifting from the P (Park) position to any drive position while the ignition switch is ON.

The selector lever cannot be moved out of the P (Park) position and into any of the other gear positions if the key is turned to the LOCK, OFF or ACC position or if the key is removed from the switch.

1. Keep the foot brake pedal depressed and shift into a driving gear.

2. Release the parking brake and foot brake, then gradually start the vehicle in motion.



WARNING

- **Do not depress the accelerator pedal while shifting from P or N to R, D, 3, 2 or 1. Always depress the brake pedal until shifting is completed. Failure to do so could cause you to lose control and have an accident.**
- **Cold engine idle speed is high, so use caution when shifting into a forward or reverse gear before the engine has warmed up.**
- **Never shift to P or R while vehicle is moving. This could cause an accident.**
- **On slippery roads, do not down-shift. This may cause a loss of**

control.

CAUTION

When stopping the vehicle on an up-hill grade, do not hold the vehicle by depressing the accelerator pedal. The foot brakes should be used for this purpose.

Shifting

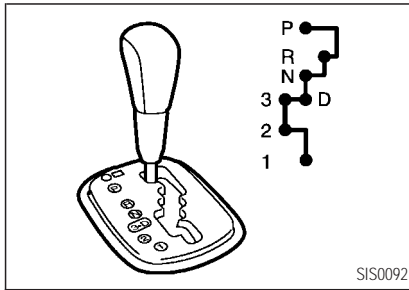

After starting the engine, fully depress the brake pedal and shift the selector lever from P (Park) to R (Reverse), D (Drive), or any of the desired shift positions.

WARNING

Apply the parking brake if the selector lever is in any position while the engine is not running. Failure to do so could cause the vehicle to move unexpectedly or roll away and result in serious personal injury or property damage.

If the key is turned to OFF or ACC for any reason while the vehicle is in R (Reverse), N (Neutral), or any D (Drive) position, the key cannot be turned to LOCK and be removed from the ignition switch. Additionally, the selector lever cannot be moved to P (Park) from N (Neutral) or any D (Drive) position.

STARTING AND DRIVING

The selector lever can be moved from R (Reverse) to P (Park) with the key in the OFF or ACC position. If the key cannot be turned to LOCK, perform the following steps:

1. Apply the parking brake when the vehicle is stopped.
2. Turn the key to ON while depressing the foot brake pedal.
3. Move the selector lever to P (Park).
4. Turn the ignition key to LOCK to remove the key.

P (Park):

Use this selector position when the vehicle is parked or when starting the engine. Make sure the vehicle is completely stopped. **The brake pedal must be depressed to move the selector lever from N (Neutral) or any drive position to P (Park).** Apply the parking brake. When parking on a hill, apply the

STARTING AND DRIVING

parking brake first, then move the lever to the P (Park) position.



Use this position only when the vehicle is completely stopped.

R (Reverse):

Use this position to back up. Always be sure the vehicle is completely stopped when selecting R (Reverse). **The brake pedal must be depressed to move the selector lever from P (Park), N (Neutral) or any drive position to R (Reverse).**

N (Neutral):

Neither forward nor reverse gear is engaged. The engine can be started in this position. You may shift to N (Neutral) and restart a stalled engine while the vehicle is moving.

D (Drive):

Use this position for all normal forward driving.

3 (Third gear):

For driving up and down long slopes where engine braking would be advantageous.

2 (Second gear):

Use for hill climbing or engine braking on downhill grades.

Do not exceed 69 MPH (110 km/h) in the 2 (Second gear) position.

1 (Low gear):

Use this position when climbing steep hills slowly or driving slowly through deep snow, sand or mud, or for maximum engine braking on steep downhill grades.

Do not exceed 37 MPH (60 km/h) in the 1 (Low gear) position.

Shift lock release

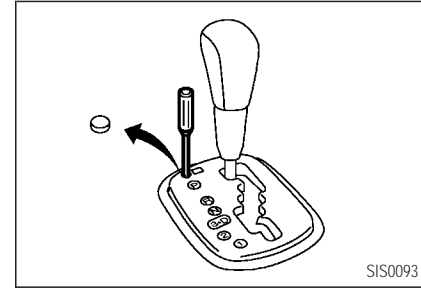

If the battery charge is low or discharged, the select lever may not move from the P position even with the brake pedal depressed.

To move the select lever, depress the brake pedal, and push the shift lock release button. The select lever can be moved to N (Neutral).

This allows the vehicle to be moved if the battery is discharged.

If the lever cannot be moved out of P (Park) have your INFINITI retailer check the auto-

matic transmission system as soon as possible.



WARNING

If the selector lever cannot be moved from the P position while the engine is running and the brake pedal is depressed, the stop lights may not work. Malfunctioning stop lights could cause an accident injuring yourself and others.

Accelerator downshift — In D position —

For rapid passing or hill climbing, fully depress the accelerator pedal to the floor. This shifts the transmission down into second gear or first gear, depending on the vehicle speed.

Fail-safe

When the fail-safe operation occurs, the next time the key is turned to the ON position, the **AT CHECK** light will blink for approximately 8 seconds after coming on for 2 seconds. While the vehicle can be driven under these circumstances please note that the gears in the automatic transmission will be locked in third gear.

If the vehicle is driven under extreme conditions, such as excessive wheel spinning and subsequent hard braking, the fail-safe system may be activated. This will occur even if all electrical circuits are functioning properly. In this case, turn the ignition key OFF and wait for 3 seconds. Then turn the key back to the ON position. The vehicle should return to its normal operating condition. If it does not return to its normal operating condition, have your INFINITI retailer

STARTING AND DRIVING

check the transmission and repair if necessary.

PARKING BRAKE

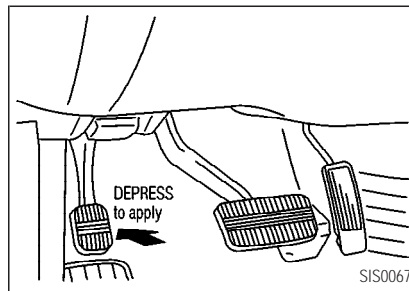

To apply: Fully depress the parking brake pedal.

To release:

1. Firmly apply the foot brake.
2. Depress the parking brake pedal and the parking brake will be released.

STARTING AND DRIVING

3. Before driving, be sure the brake warning light goes out.



WARNING

- *Be sure the parking brake is fully released before driving. Failure to do so can cause brake failure and lead to an accident.*
- *Do not release the parking brake from outside the vehicle.*
- *Do not use the gear shift in place of the parking brake. When parking, be sure the parking brake is fully engaged.*
- *Do not leave children unattended in a vehicle. They could release the parking brake and cause an accident.*

CRUISE CONTROL



WARNING

Do not use the cruise control when driving under the following conditions:

- *it is not possible to keep the vehicle at set speed.*
- *in heavy traffic or in traffic that varies in speed.*
- *on winding roads, or hilly roads.*
- *on slippery roads (rain, snow, ice, etc.)*
- *in very windy areas.*

Doing so could cause a loss of vehicle control and result in an accident.

PRECAUTIONS ON CRUISE CONTROL

- If the cruise control system malfunctions, it will cancel automatically. The cruise indicator light in the instrument panel will then blink to warn the driver.
- When the cruise indicator light blinks, turn the cruise control switch (main switch) OFF and have the system checked by your INFINITI retailer.
- The cruise indicator light may blink when the cruise control main switch is turned ON while pushing the RES/ACCEL, COAST/SET, or CANCEL switch (located on the steering wheel). To properly set the cruise control system perform the steps above in the order indicated.

CRUISE CONTROL OPERATIONS

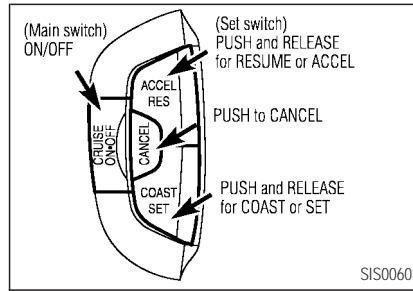

The cruise control allows driving at a speed between 25 to 89 MPH (40 to 144 km/h) without keeping your foot on the accelerator pedal.

To turn on the cruise control, push the main switch on. The cruise indicator light on the meter panel will come on.

To set at cruising speed, accelerate your vehicle to the desired speed, push the

COAST/SET switch and release it. (The SET indicator light will come on.) Take your foot off the accelerator pedal. Your vehicle will maintain the set speed.

- **To pass another vehicle,** depress the accelerator pedal. When you release the pedal, the vehicle will return to the previously set speed.
- The vehicle may not maintain the set speed when going up or down steep hills. If this happens, drive without the cruise control.

To cancel the preset speed, follow any of these methods:

- a) Push the CANCEL switch; The SET indicator light will go out.
- b) Tap the brake pedal; The SET indicator light will go out.
- c) Turn the main switch off. Both the CRUISE indicator and SET indicator lights will go out.

STARTING AND DRIVING

- If you depress the brake pedal while pushing the RES/ACCEL set switch and reset at the cruising speed, turn the main switch off once and then turn it on again.
- The cruise control will automatically be cancelled if the vehicle slows down below approximately 8 MPH (13 km/h).
- Move the selector lever to N (Neutral) position. The SET light will go out.

To reset at a faster cruising speed, use one of the following three methods:

- a) Depress the accelerator pedal. When the vehicle attains the desired speed, push and release the COAST/SET switch.
- b) Push and hold the RES/ACCEL set switch. When the vehicle attains the speed you desire, release the switch.
- c) Push, then quickly release the RES/ACCEL set switch. Each time you do this, the set

STARTING AND DRIVING

speed will increase by about 1 MPH (1.6 km/h).

To reset at a slower cruising speed, use one of the following three methods:

- a) Lightly tap the brake pedal. When the vehicle attains the desired speed, push the COAST/SET switch and release it.
- b) Push and hold the COAST/SET switch. Release the switch when the vehicle slows down to the desired speed.
- c) Push, then quickly release the COAST/SET switch. Each time you do this, the set speed will decrease by about 1 MPH (1.6 km/h).

To resume the preset speed, push and release the RES/ACCEL set switch. The vehicle will resume the last set cruising speed when the vehicle speed is over 25 MPH (40 km/h).

BREAK-IN SCHEDULE

During the first 1,200 miles (2,000 km), follow

these recommendations to obtain maximum engine performance and ensure the future reliability and economy of your new vehicle. Failure to follow these recommendations may result in shortened engine life and reduced engine performance.

- Avoid driving for long periods at constant speed, either fast or slow. Do not run the engine over 4,000 rpm.
- Do not accelerate at full throttle in any gear.
- Avoid quick starts.
- Avoid hard braking as much as possible.
- Do not tow a trailer for the first 500 miles (800 km).

INCREASING FUEL ECONOMY

- Accelerate slowly and smoothly. Maintain cruising speeds with a constant accelerator position.

- Drive at moderate speeds on the highway. Driving at high speed will lower fuel economy.
- Avoid unnecessary stopping and braking. Maintain a safe distance behind other vehicles.
- Use a proper gear range which suits road conditions. On level roads, shift into high gear as soon as possible.
- Avoid unnecessary engine idling.
- Keep your engine tuned up.
- Follow the recommended periodic maintenance schedule.
- Keep the tires inflated at the correct pressure. Low pressure will increase tire wear and waste fuel.
- Keep the front wheels in correct alignment. Improper alignment will cause not only tire wear but also lower fuel economy.

STARTING AND DRIVING

- Air conditioner operation lowers fuel economy. Use the air conditioner only when necessary.
- When cruising at highway speeds, it is more economical to use the air conditioner and leave the windows closed to reduce drag.

PARKING/PARKING ON HILLS

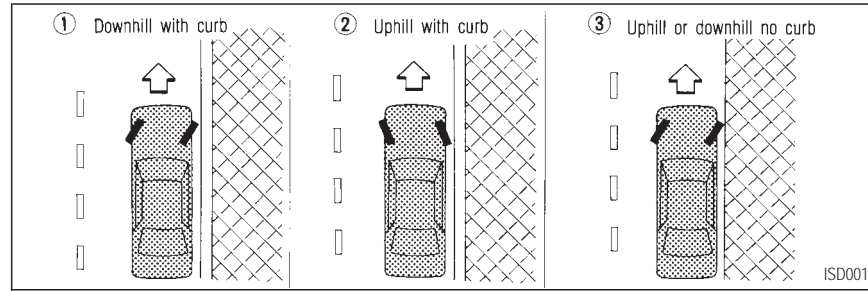

WARNING

- *Do not stop or park the vehicle over flammable materials such as dry grass, waste paper or rags. They may ignite and cause a fire.*
- *Never leave the engine running*

while the vehicle is unattended.

- *Never leave children unattended in the vehicle.*

1. Firmly apply the parking brake.
2. Move the selector lever to the P (Park) position.

STARTING AND DRIVING



WARNING

- *Safe parking procedures require that both the parking brake be set and the transmission placed into P (Park) for automatic transmission models. Failure to do so could cause the vehicle to move unexpectedly or roll away and result in an accident.*
 - *Make sure the automatic transmission selector lever has been pushed as far forward as it can go and cannot be moved without depressing the button at the end of the lever.*
3. To help prevent the vehicle from rolling into the street when parked on a sloping drive way, it is a good practice to turn the wheels as illustrated.

5-16

- HEADED DOWNHILL WITH CURB: ①

Turn the wheels into the curb and move the vehicle forward until the curb side wheel gently touches the curb.

- HEADED UPHILL WITH CURB: ②

Turn the wheels away from the curb and move the vehicle back until the curb side wheel gently touches the curb.

- HEADED UPHILL OR DOWNHILL, NO CURB: ③

Turn the wheels toward the side of the road so the vehicle will move away from the center of the road if it moves.

4. Turn the ignition key to the LOCK position and remove the key.

POWER STEERING

The power assisted steering is designed to use a hydraulic pump, driven by the engine, to assist steering.

If the engine stops or drive belt breaks, you will still have control of the vehicle. However, much greater steering effort is needed, especially in sharp turns or at low speeds.



WARNING

If the engine is not running or is turned off while driving, the power assist for the steering will not work. Steering will be much harder to operate.

BRAKE SYSTEM

BRAKING PRECAUTIONS

The brake system has two separate hydraulic circuits. If one circuit malfunctions, you will still have braking at two wheels.

Vacuum assisted brake

The brake booster aids braking by using

engine vacuum. If the engine stops, you can stop the vehicle by depressing the brake pedal. However, greater foot pressure on the brake pedal will be required to stop the vehicle and the stopping distance will be longer.

Wet brakes

When the vehicle is washed or driven through water, the brakes may get wet. As a result, your braking distance will be longer and the vehicle may pull to one side during braking. To dry brakes, drive the vehicle at a safe speed while lightly pressing the brake pedal to heat-up the brakes. Do this until the brakes return to normal. Avoid driving the vehicle at high speeds until the brakes function correctly.

Using the brakes

Avoid resting your foot on the brake pedal while driving. This will overheat the brakes, wear out the brake linings and pads faster and reduce gas mileage.

To help save the brakes and to prevent the brakes from overheating, reduce speed and downshift to a lower gear before going down a slope or long grade. Overheated brakes may reduce braking performance and could result in loss of vehicle control.



WARNING

- ***While driving on a slippery surface, be careful when braking, accelerating or downshifting. Abrupt braking or accelerating could cause the wheels to skid and result in an accident.***
- ***If the engine is not running or is turned off while driving, the power assist for the brakes will not work. Braking will be harder.***

STARTING AND DRIVING

ANTI-LOCK BRAKE SYSTEM (ABS)

The anti-lock brake system controls the brakes at each wheel so the wheels will not lock when braking abruptly or when braking on slippery surfaces. The system detects the rotation speed at each wheel and varies the brake fluid pressure to prevent each wheel from locking and sliding. By preventing wheel lockup, the system helps the driver maintain steering control and helps to minimize swerving and spinning on slippery surfaces.

Using the system

Depress the brake pedal and hold it down.



WARNING

Do not pump the brake pedal. Doing so may result in increased stopping distances.

STARTING AND DRIVING

Normal operation

The anti-lock brake system will not operate at speeds below 3 to 6 MPH (5 to 10 km/h) to completely stop the vehicle. (The speeds will vary according to road conditions.) When the anti-lock system senses that one or more wheels are close to locking up, the actuator (under the hood) rapidly applies and releases hydraulic pressure (like pumping the brakes very quickly). While the actuator is working, you may feel a pulsation in the brake pedal and hear a noise or vibration from the actuator under the hood. This is normal and indicates that the anti-lock system is working properly. However, the pulsation may indicate that road conditions are hazardous and extra care is required while driving.

Self-test feature

The anti-lock brake system consists of electronic sensors, electric pumps, and hydraulic solenoids controlled by a computer. The

computer has a built-in diagnostic feature that tests the system each time you start the engine and move the vehicle at a low speed in forward or reverse. When the self-test occurs, you may hear a clunk noise and/or feel a pulsation in the brake pedal. This is normal and is not an indication of any malfunction. If the computer senses any malfunction, it switches the anti-lock brake system OFF and turns on the ABS warning light in the dashboard. The brake system will then behave normally, but without anti-lock assistance.

If the light comes on during the self check, or while you are driving, you should take your vehicle to your INFINITI retailer for repair at your earliest convenience.



WARNING

The anti-lock brake system is a sophisticated device, but it cannot pre-

vent accidents resulting from careless or dangerous driving techniques. It can help maintain vehicle control during braking on slippery surfaces, but remember that the stopping distance on slippery surfaces will be longer than on normal surfaces, even with the anti-lock system. Stopping distances may also be longer on rough, gravel or snow covered roads, or if you are using tire chains. Always maintain a safe distance from the vehicle in front of you. Ultimately, the responsibility for safety of self and others rests in the hands of the driver.

Tire type and condition of tires may also affect braking effectiveness.

- ***When replacing tires, install the specified size of tires on all four***

wheels.

- *When installing a spare tire, make sure it is the proper size and type as specified on the tire placard. See “Vehicle identification” in the “10. Technical and consumer information” section for tire placard location.*

TRACTION CONTROL SYSTEM (if so equipped)

On slippery surfaces such as wet asphalt roads, vehicle wheels may spin when the vehicle is accelerated. This wheel spin reduces acceleration, or causes the vehicle to swerve, thus decreasing vehicle stability.

The traction control system helps limit wheel spin on slippery roads. The system operates only if it senses one or both of the front wheels spinning or beginning to lose traction.

When this happens, the system reduces engine power and may also upshift the transmission to help limit wheel spin.

- Indicator light
If a malfunction occurs in the traction control system, the SLIP and  indicator lights come on in the meter panel. As long as these warning lights are on, the traction control function is canceled. The vehicle will behave like a model without the traction control system.

CAUTION

- *The traction control system is most effective when the transmission gear selector is in the D position.*
- *If you drive in gear 1 or 2 with the TCS on, this could cause the three*

STARTING AND DRIVING

way catalyst to overheat and be damaged. To avoid this, the TCS will automatically turn off. Shifting the gear selector to D will reactivate the TCS.



WARNING

This system is designed to prevent the wheels from spinning. However, it does not prevent vehicle slipping or spinning due to abrupt steering operation at high speeds or by careless or dangerous driving techniques. Be especially careful when driving on slippery surfaces and always drive safely.

STARTING AND DRIVING

VEHICLE DYNAMIC CONTROL SYSTEM (VDC) (if so equipped)

When driving on slippery surfaces or suddenly avoiding obstacles on roads, the vehicle might swerve or slip. With the vehicle dynamic control system, sensors detect these movements and control the braking and engine output to help improve vehicle stability while driving.

- When the vehicle dynamic control system is operating, the slip indicator in the instrument panel blinks.
- When only the traction control system in the vehicle dynamic control system is operating, the slip indicator blinks.
- If the slip indicator blinks, the vehicle is under slippery conditions. Be sure to drive carefully. See "Slip indicator light", and "Vehicle dynamic control off indicator

light" in the "Instruments and controls" section.

- Indicator light

If a malfunction occurs in the system, the SLIP and **VDC OFF** indicator lights come on in the meter panel.

As long as these warning lights are on, the traction control function is canceled. The vehicle will behave like a model without the system.



WARNING

- *The vehicle dynamic control system is designed to help improve driving stability but does not prevent accidents due to abrupt steering operation at high speeds or by careless or dangerous driving techniques. Reduce vehicle speed and be especially careful*

when driving and cornering on slippery surfaces and always drive carefully.

- *If suspension parts such as shock absorbers, struts, springs and bushings are not standard equipment or are extremely deteriorated, the vehicle dynamic control off indicator light may come on.*
- *When driving on extremely inclined surfaces such as higher banked corners, the vehicle dynamic control system may not operate properly or the vehicle dynamic control off indicator light may come on. Do not drive on these types of roads.*
- *If the tires other than the recommended ones are used, the ve-*

hicle dynamic control system may not operate properly or the vehicle dynamic control off indicator light may come on.

- *The vehicle dynamic control system is not a substitute for winter tires or tire chains on a snow covered road.*

COLD WEATHER DRIVING

FREEDING A FROZEN DOOR LOCK

To prevent a door lock from freezing, apply de-icer or glycerin to it through the key hole. If the lock becomes frozen, heat the key before inserting it into the key hole.

ANTI-FREEZE

In the winter when it is anticipated that the temperature will drop below 32°F (0°C),

check anti-freeze to assure proper winter protection. For additional information, see “Engine cooling system” in the “8. Do-it-yourself” section.

BATTERY

If the battery is not fully charged during extremely cold weather conditions, the battery fluid may freeze and damage the battery. To maintain maximum efficiency, the battery should be checked regularly. For additional information, see “Battery” in the “8. Do-it-yourself” section.

DRAINING OF COOLANT WATER

If the vehicle is to be left outside without anti-freeze, drain the cooling system by opening the drain valves located under the radiator and on the engine block. Refill before operating the vehicle. See “Engine cooling system” in the “8. Do-it-yourself” section for changing engine coolant.

STARTING AND DRIVING

TIRE EQUIPMENT

1. SUMMER tires are of a tread design to provide superior performance on dry pavement. However, the performance of these tires will be substantially reduced in snowy and icy conditions. If you operate your vehicle on snowy or icy roads, INFINITI recommends the use of MUD & SNOW or ALL SEASON tires on all four wheels. Please consult your INFINITI retailer for the tire type, size, speed rating and availability information.
2. For additional traction on icy roads, studded tires may be used. However, some provinces and states prohibit their use. Check local, state and provincial laws before installing studded tires.

Skid and traction capabilities of studded snow tires, on wet or dry surfaces, may be poorer than that of non-studded snow tires.

STARTING AND DRIVING

3. Tire chains may be used if desired. Make sure they are of proper size for the tires on your vehicle and are installed according to the chain manufacturer's suggestions. Use of tire chains may be prohibited according to location. Check the local laws before installing tire chains. When installing tire chains, make sure they are of proper size for the tires on your vehicle and are installed according to the chain manufacturer's suggestions. **Use only SAE Class S chains.** Class "S" chains are used on vehicles with restricted tire to vehicle clearance. Vehicles that can use Class "S" chains are designed to meet the SAE standard minimum clearances between the tire and the closest vehicle suspension or body component required to accommodate the use of a winter traction device (tire chains or cables). The minimum clearances are determined using the factory equipped tire size. Other types may damage your vehicle. Use chain tensioners

when recommended by the tire chain manufacturer to ensure a tight fit. Loose end links of the tire chain must be secured or removed to prevent the possibility of whipping action damage to the fenders or underbody. If possible, avoid fully loading your vehicle when using tire chains. In addition, drive at a reduced speed. Otherwise, your vehicle may be damaged and/or vehicle handling and performance may be adversely affected.

Never install tire chains on a T-type spare tire. Do not use tire chains on dry roads.

SPECIAL WINTER EQUIPMENT

It is recommended that the following items be carried in the vehicle during winter:

- a scraper and stiff-bristled brush to remove ice and snow from the windows and wiper blades.
- a sturdy, flat board to be placed under the jack to give it firm support.

- a shovel to dig the vehicle out of snow-drifts.
- extra window washer fluid to refill the reservoir tank.

DRIVING ON SNOW OR ICE



WARNING

- ***Wet ice (32°F, 0°C and freezing rain), very cold snow or ice can be slick and very hard to drive on. The vehicle will have a lot less traction or grip under these conditions. Try to avoid driving on wet ice until the road is salted or sanded.***
- ***Whatever the condition, drive with caution. Accelerate and slow down with care. If accelerating or downshifting too fast, the drive wheels will lose even more traction.***

STARTING AND DRIVING

- *Allow more stopping distance under these conditions. Braking should be started sooner than on dry pavement.*
- *Allow greater following distances on slippery roads.*
- *Watch for slippery spots (glare ice). These may appear on an otherwise clear road in shaded areas. If a patch of ice is seen ahead, brake before reaching it. Try not to brake while actually on the ice, and avoid any sudden steering maneuvers.*
- *Do not use cruise control on slippery roads.*

- *Snow can trap dangerous exhaust gases under your vehicle. Keep snow clear of the exhaust pipe and from around your vehicle.*

ENGINE BLOCK HEATER (if so equipped)

An engine block heater to assist extreme cold temperature starting is available through your INFINITI retailer.



WARNING

Do not use your heater with an ungrounded electrical system or two-pronged (cheater) adapters. You can be injured by an electrical shock if you use an ungrounded connection.

6 IN CASE OF EMERGENCY

Roadside assistance program	6-2	If your vehicle overheats.....	6-10
Flat tire	6-2	Towing your vehicle	6-12
Changing a flat tire	6-2	Towing recommended by INFINITI	6-12
Jump starting	6-7	Vehicle recovery (Freeing a stuck	
Push starting.....	6-10	vehicle)	6-14

IN CASE OF EMERGENCY

ROADSIDE ASSISTANCE PROGRAM

Every new INFINITI comes with a 4 year, unlimited mileage Roadside Assistance plan. In the event of a roadside emergency, Roadside Assistance Service is available to you. Please refer to your Warranty Booklet for details. Both the Warranty Booklet and Roadside Assistance Calling Card in your Owner's Literature Portfolio provide the Toll-Free Number to call for assistance. Roadside Assistance is provided 24 hours a day, 365 days a year, for four years from the date sold to give emergency roadside help, in the event of mechanical or nonmechanical trouble(s) such as flat tires, out-of-gas, dead battery, lost keys mechanical breakdown, accident, etc.

FLAT TIRE

CHANGING A FLAT TIRE

If you have a flat tire, follow the instructions below.

Stopping the vehicle

1. Safely move the vehicle off the road away from traffic.
2. Turn on the hazard warning flashers.
3. Park on a level surface and apply the parking brake. Shift the manual transmission into the R (Reverse) position (automatic transmission in the P (Park) position).
4. Turn off the engine.
5. Raise the hood to warn other traffic, and to signal professional road assistance personnel that you need assistance.
6. Have all passengers get out of the vehicle and stand in a safe place, away from traffic

and clear of the vehicle.



WARNING

- *Make sure that the parking brake is securely applied and the manual transmission is shifted into R (Reverse), or the automatic transmission into P (Park).*
- *Never change tires when the vehicle is on a slope, ice or slippery areas. This is hazardous.*
- *Never change tires if oncoming traffic is close to your vehicle. Wait for professional road assistance.*

Blocking wheels

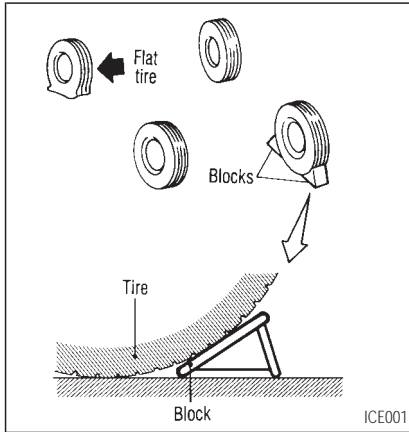

Place suitable blocks at both the front and back of the wheel diagonally opposite the flat tire to prevent the vehicle from rolling when it is jacked up.



WARNING

Be sure to block the wheel as the vehicle may move and could cause personal injury.

IN CASE OF EMERGENCY

Getting the spare tire and tools

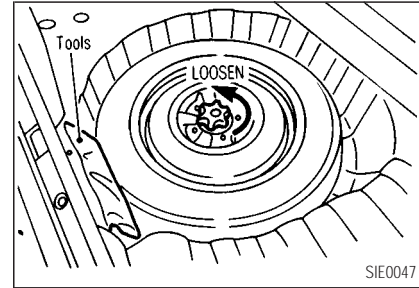

IN CASE OF EMERGENCY

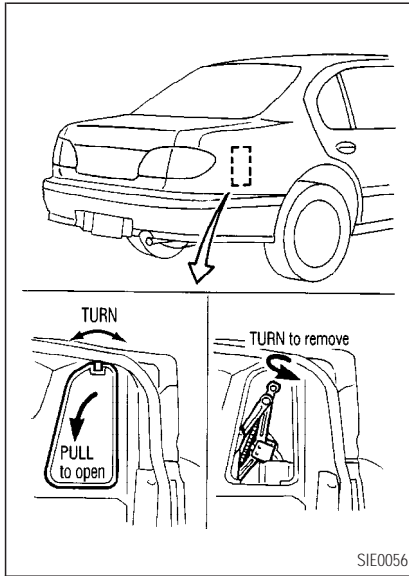

Remove jacking tools and spare tire from the storage area located inside the trunk as illustrated.

Jacking up the vehicle and removing the damaged tire

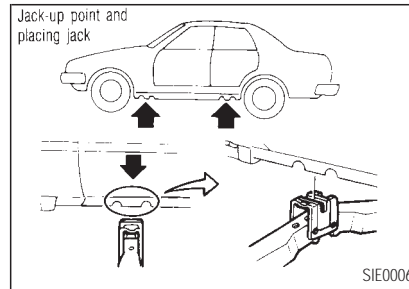

Carefully read the caution label attached to the jack body and the following instructions.

IN CASE OF EMERGENCY

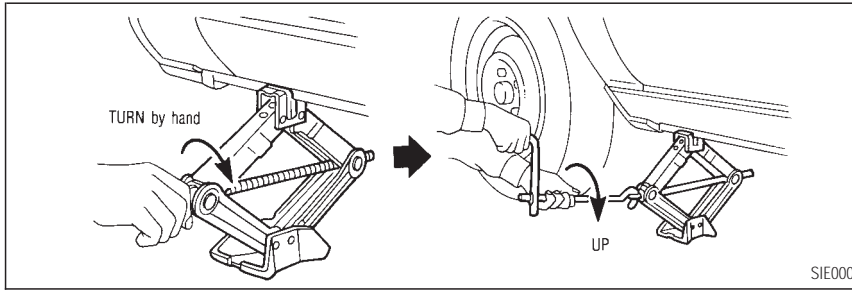

1. Place the jack directly under the jack-up point as illustrated above so that top of the jack contacts the vehicle at the jack up point. Align the jack head between the two notches in the front or the rear as shown. Also fit the groove of the jack head between the notches as shown.

The jack should be used on level firm ground.

2. Loosen each wheel nut one or two turns by turning counterclockwise with the wheel nut wrench. **Do not remove the wheel nuts until the tire is off the ground.**
3. Carefully raise the vehicle until the tire clears the ground. To lift the vehicle, securely hold the jack lever and rod with both hands as shown above. Remove the wheel nuts, and then remove the tire.

WARNING

- *Never get under the vehicle while it is supported only by the jack.*
- *Use only the jack provided with your vehicle to lift the vehicle. Do not use the jack provided with your vehicle on other vehicles. The jack is designed only for lifting your vehicle during a tire change.*
- *Use the correct jack up points; never use any other part of the vehicle for jack support.*
- *Never jack up the vehicle more than necessary.*
- *Never use blocks on or under the jack.*

IN CASE OF EMERGENCY

- *Do not start or run engine while vehicle is on the jack, as it may cause the vehicle to move. This is especially true for vehicle with limited slip differential carrier.*
- *Do not allow passengers to stay in the vehicle while it is on the jack.*

Installing the spare tire

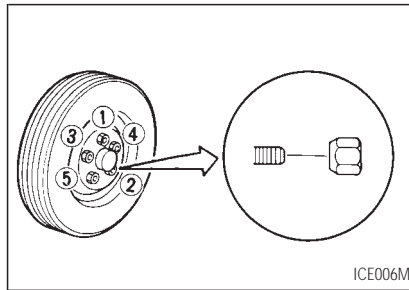

1. Clean any mud or dirt from the surface between the wheel and hub.
2. Carefully put the wheel on and tighten the wheel nuts finger tight.
3. With the wheel nut wrench, tighten wheel nuts alternately and evenly until they are tight.
4. Lower the vehicle slowly until the tire touches the ground. Then, with the wheel nut wrench, tighten the wheel nuts securely in the sequence as illustrated.

WARNING

- *Incorrect wheel nuts or improperly tightened wheel nuts can cause the wheel to become loose or come off. This could cause an accident.*

- *Do not use oil or grease on the wheel studs or nuts. This could cause the nuts to become loose.*

As soon as possible tighten the wheel nuts to the specified torque with a torque wrench.

Wheel nut tightening torque:

80 ft-lb
(108 N-m)

Adjust tire pressure to the COLD pressure.

COLD pressure:

After vehicle has been parked for three hours or more or driven less than 1 mile (1.6 km).

COLD tire pressures are shown on the tire placard affixed to the center console lid.



WARNING

Retighten the wheel nuts when the vehicle has been driven for 600 miles (1,000 km) (also in cases of a flat tire, etc.).

Stowing the damaged tire and tools

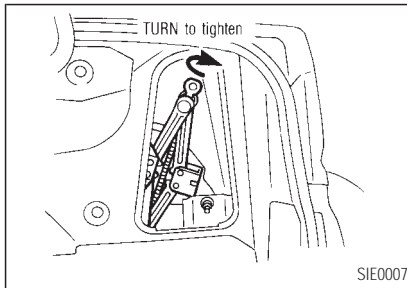

Securely store the damaged tire and jacking equipment in the vehicle.



WARNING

- Always make sure that the spare tire and jacking equipment are properly secured after use. Such items can become dangerous projectiles in an accident or sudden stop.
- The T-type spare tire and small size spare tire are designed for emergency use. See “Wheels and tires” in the “8. Do-it-yourself” section.

If needed, Roadside Assistance is available. Please see your Warranty Booklet or Roadside Assistance I.D. Card for the toll-free number to call.

JUMP STARTING

To start your engine with a booster battery,

IN CASE OF EMERGENCY

the instructions and precautions below must be followed.



WARNING

- If done incorrectly, jump starting can lead to a battery explosion, resulting in severe injury or death. It could also damage your vehicle.
- Explosive hydrogen gas is always present in the vicinity of the battery. Keep all sparks and flames away from the battery.
- Do not allow battery fluid to come into contact with eyes, skin, cloth or painted surfaces. Battery fluid is a corrosive sulphuric acid solution which can cause severe burns. If the fluid should come into contact with anything,

IN CASE OF EMERGENCY

immediately flush the contacted area with water.

- *Keep battery out of the reach of children.*
- *The booster battery must be rated at 12 volts. Use of an improperly rated battery can damage your vehicle.*
- *Whenever working on or near a battery, always wear suitable eye protectors (For example, goggles or industrial safety spectacles) and remove rings, metal bands, or any other jewelry. Do not lean over the battery when jump starting.*
- *Do not attempt to jump start a frozen battery. It could explode and cause serious injury.*

- *Your vehicle has an automatic engine cooling fan. It could come on at any time. Keep hands and other objects away from it.*

If needed, Roadside Assistance is available. Please see your Warranty Information Booklet or Roadside Assistance I.D. Card for the toll-free number to call.

IN CASE OF EMERGENCY

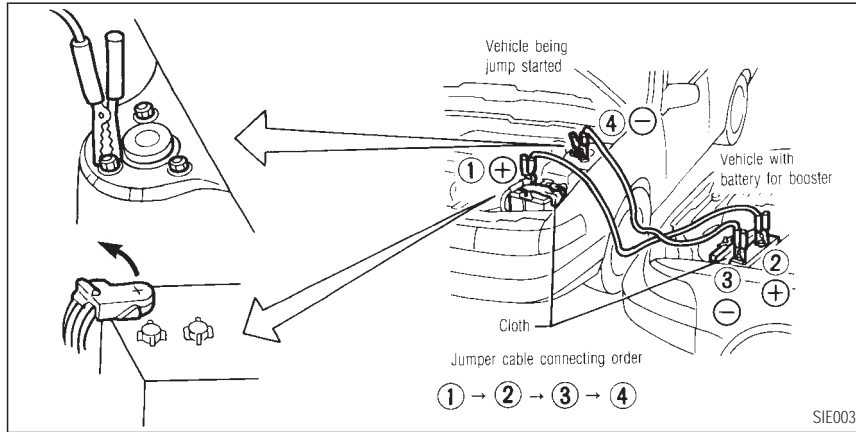

WARNING

Always follow the instructions below. Failure to do so could result in damage to the charging system and

cause personal injury.

1. If the booster battery is in another vehicle, position the two vehicles to bring their batteries into close proximity to each other.



CAUTION

- *Always connect positive (+) to positive (+) and negative (-) to body ground (For example, strut mounting bolt, etc. — not to the*

Do not allow the two vehicles to touch.

2. Apply parking brake. Move the shift lever to the N (Neutral) position (On automatic transmission models, move the selector lever to the P (Park) position). Switch off all unnecessary electrical systems (light, heater, air conditioner, etc.).
3. Remove vent caps on the battery (if so equipped). Cover the battery with an old cloth to reduce explosion hazard.
4. Connect jumper cables in the sequence as illustrated.

IN CASE OF EMERGENCY

battery).

- ***Make sure that cables do not touch moving parts in the engine compartment and that clamps do not contact any other metal.***
5. Start the engine of the other vehicle and let it run for a few minutes.
 6. Keep the engine speed of the other vehicle at about 2,000 rpm, and start your engine in the normal manner.



CAUTION

Do not keep starter motor engaged for more than 10 seconds. If the engine does not start right away, turn the key off and wait 3 to 4 seconds before trying again.

7. After starting your engine, carefully disconnect the negative cable and then the positive cable.
8. Replace the vent caps (if so equipped). Be sure to dispose of the cloth used to cover the vent holes as it may be contaminated with corrosive acid.

PUSH STARTING

Do not start the engine by pushing.



CAUTION

- ***Automatic transmission models cannot be push started. This may cause transmission damage.***
- ***Three way catalyst equipped models should not be started by pushing since the three way catalyst may be damaged.***

- ***Never try to start the vehicle by towing it; when the engine starts, the forward surge could cause the vehicle to collide with the tow vehicle.***

If needed Roadside Assistance is available. Please see your Warranty Information Booklet or Roadside Assistance I.D. Card for the toll-free number to call.

IF YOUR VEHICLE OVERHEATS



WARNING

- ***Do not continue to drive if your vehicle overheats. Doing so could cause a vehicle fire.***

- *To avoid the danger of being scalded, never remove the radiator cap while the engine is still hot. When the radiator cap is removed, pressurized hot water will spurt out, possibly causing serious injury.*
- *Do not open the hood if steam is coming out.*

If your vehicle is overheating (indicated by an extremely high temperature gauge reading), or if you feel a lack of engine power, detect abnormal noise, etc., take the following steps:

1. Move the vehicle safely off the road, apply the parking brake and move the shift lever to the N (Neutral) position (automatic transmission to the P (Park) position).

Do not stop the engine.

2. Turn off the air conditioner switch. Open

all the windows, move the heater or air conditioner temperature control to maximum hot and fan control to high speed.

3. Get out of the vehicle. Look and listen for steam or coolant escaping from the radiator before opening the hood. Wait until no steam or coolant can be seen before proceeding.
4. Open the engine hood.



WARNING

If steam or water is coming from the engine, stand clear to prevent getting burned.

5. Visually check if the cooling fan is running. The radiator hoses and radiator should not leak water. If coolant is leaking or the cooling fan does not run, stop the engine.

IN CASE OF EMERGENCY



WARNING

- *Be careful not to allow your hands, hair, jewelry or clothing to come into contact with, or to get caught in the cooling fan, or drive belt.*
- *The engine cooling fan can start at any time when the coolant temperature is high.*

6. After the engine cools down, check the coolant level in the reservoir tank with the engine running. Add coolant to the reservoir tank if necessary. Have your vehicle repaired at the nearest INFINITI retailer.

If needed, Roadside Assistance is available. Please see your Warranty Information Booklet or Roadside Assistance I.D. Card for the toll-free number to call.

IN CASE OF EMERGENCY

TOWING YOUR VEHICLE

When towing your vehicle, all State (Provincial in Canada) and local regulations for towing must be followed. Incorrect towing equipment could damage your vehicle. Towing instructions are available from an authorized INFINITI retailer. Local service operators are generally familiar with the applicable laws and procedures for towing. To assure proper towing and to prevent accidental damage to your vehicle, INFINITI recommends having a service operator tow your vehicle. It is advisable to have the service operator carefully read the following precautions:

WARNING

- **Never ride in a vehicle that is being towed.**
- **Never get under your vehicle after it has been lifted by a tow truck.**

CAUTION

- **When towing, make sure that the transmission, axles, steering system and powertrain are in working condition. If any unit is damaged, dollies must be used.**
- **Always attach safety chains before towing.**

If needed, Roadside Assistance is available. Please see your Warranty Information Booklet or Roadside Assistance I.D. Card for the toll-free number to call.

For Canada models, Warranty & Roadside assistance Information booklet.

TOWING RECOMMENDED BY INFINITI

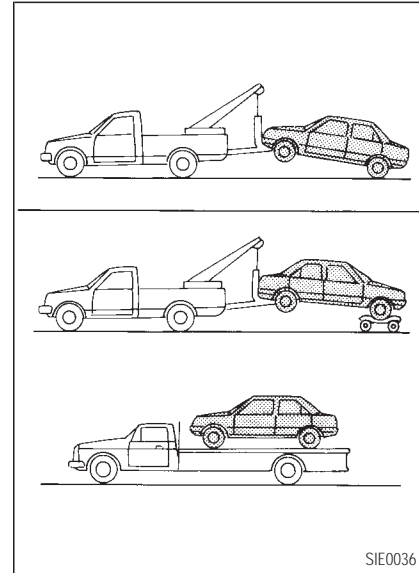

INFINITI recommends that your vehicle be

towed with the driving (front) wheels off the ground or place the vehicle on a flat bed truck as illustrated.

 **CAUTION**

- *Never tow automatic transmission models with the front wheels on the ground or four wheels on the ground (forward or backward), as this may cause serious and expensive damage to the transmission. If it is necessary to tow the vehicle with the rear wheels raised, always use towing dollies under the front wheels.*
- *When towing automatic transmission models with the front wheels on towing dollies, or when towing manual transmission models with the front wheels on the ground:*

- *Turn the ignition key to the OFF position, and secure the steering wheel in a straight ahead position with a rope or similar device. Never secure the steering wheel by turning the ignition key to the LOCK position. This may damage the steering lock mechanism.*
- *Move the shift lever to the N (Neutral) position.*
- *When towing automatic or manual transmission models with the rear wheels on the ground (if you do not use towing dollies): Always release the parking brake.*

IN CASE OF EMERGENCY

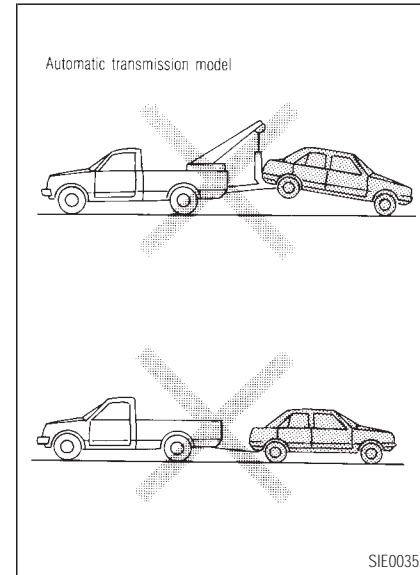

IN CASE OF EMERGENCY

VEHICLE RECOVERY (Freeing a stuck vehicle)

- Tow chains or cables must be attached only to the main structural members of the vehicle.
- Pulling devices should be routed so they do not touch any part of the suspension, steering, brake or cooling systems.
- Always pull the cable straight out from the front or rear of the vehicle. Never pull on the vehicle at an angle.
- Pulling devices such as ropes or canvas straps are not recommended for use in vehicle towing or recovery.
- Stand clear of a stuck vehicle.



WARNING

Do not spin your tires at high speed. This could cause them to explode and result in serious injury. Parts of your vehicle could also overheat and be damaged.

7 APPEARANCE AND CARE

Cleaning exterior	7-2	Floor mats.....	7-5
Washing.....	7-2	Seat belts.....	7-5
Waxing.....	7-3	Corrosion protection.....	7-6
Removing spots	7-3	Most common factors contributing to ve-	
Underbody	7-3	hicle corrosion.....	7-6
Glass.....	7-3	Environmental factors influence the rate of	
Aluminum alloy wheels	7-4	corrosion	7-6
Chrome parts	7-4	To protect your vehicle from	
Cleaning interior	7-4	corrosion	7-6

APPEARANCE AND CARE

CLEANING EXTERIOR

In order to maintain the appearance of your vehicle, it is important to take proper care of it.

In the following cases, please wash your vehicle as soon as possible to protect the paint surface.

- After a rainfall to prevent possible damage from acid rain
- After driving on coastal roads
- When things such as soot, bird droppings, tree sap, metal particles or bugs get on the paint surface
- When dust or mud builds up on the surface

Whenever possible, store or park your vehicle inside a garage or in a covered area.

When it is necessary to park outside, park in

a shady area or protect the vehicle with a body cover.

Be careful not to scratch the paint surface when putting on or removing the body cover.

WASHING

Thoroughly rinse surface dirt off the vehicle with a wet sponge and plenty of clean water. Clean the vehicle thoroughly using a mild soap such as NISSAN Car Wash, or a general purpose dishwashing liquid mixed with clean, lukewarm (never hot) water. Rinse the vehicle again with plenty of clean water.

Inside flanges, seams and folds on the doors, hatches and hood are particularly vulnerable to the effects of road salt. Therefore, these areas must be regularly cleaned. Make sure that the drain holes in the lower edge of the door are open. Spray water under the body and in the wheel wells to loosen the dirt and wash away road salt.

Avoid leaving water spots on the paint surface by using a damp chamois to dry the vehicle.



CAUTION

- ***Do not use strong household soap, strong chemical detergents, gasoline or solvents.***
- ***Do not wash the vehicle in direct sunlight or while the vehicle body is hot, as the surface may become water-spotted.***
- ***Avoid using tight-napped or rough cloths, such as washing mitts. Care must be taken when removing caked-on dirt or other foreign substances so that the paint surface is not scratched or damaged.***

APPEARANCE AND CARE

WAXING

If you wish to wax your vehicle, only use a wax specified for use over clear coats, such as NISSAN Liquid or Spray Wax, because your INFINITI has been finished with the finest paint and hard clear coats. Your INFINITI retailer can assist you in choosing the proper product.

- Wax your vehicle only after a thorough washing. Follow the instructions supplied with the wax.
- Do not use a wax containing any abrasives, cutting compounds or cleaners that may damage the vehicle finish.
- If the surface does not polish easily, use a road tar remover and wax again.

Machine compounding or aggressive polishing on a base coat/clear coat paint finish may dull the finish or leave swirl marks.

REMOVING SPOTS

Remove tar and oil spots, industrial dust, insects, and tree sap as quickly as possible from the paint surface to avoid lasting damage or staining. Special cleaning products are available at your INFINITI retailer or automotive accessory stores.

UNDERBODY

In areas where road salt is used in winter, the underbody must be cleaned regularly. This will prevent dirt and salt from building up and causing underbody and suspension corrosion. Before the winter period and again in the spring, the underseal must be checked and, if necessary, re-treated.

GLASS

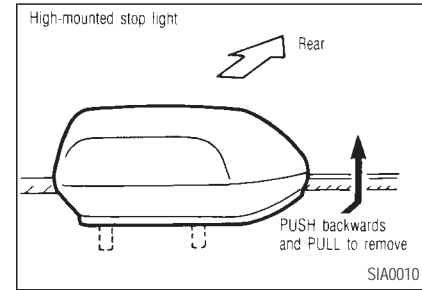

Use glass cleaner to remove smoke and dust film from the glass surfaces. It is normal for glass to become coated with a film after the vehicle is parked in the hot sun. Glass cleaner and a soft cloth will easily remove this film.

APPEARANCE AND CARE



CAUTION

When cleaning the inside of the window, do not use sharp-edged tools, abrasive cleaners or chlorine based disinfectant cleaners. They could damage the electrical conductors, radio antenna elements or rear window defogger elements.

ALUMINUM ALLOY WHEELS

Wash regularly, especially during winter months in areas where road salt is used. Salt could discolor the wheel if not removed.

CHROME PARTS

Clean chrome parts regularly with a non-abrasive chrome polish to maintain the finish.

CLEANING INTERIOR

Occasionally remove loose dust from the

interior trim, plastic parts and seats using a vacuum cleaner or soft brush.

When interior trim or seats are stained, clean immediately as follows:

- wipe clean using a clean, soft damp cloth and a neutral detergent. Wipe off all traces of the detergent with another clean soft damp cloth, finishing with a soft dry cloth.
- if the above method does not remove the stains, etc., rub the affected area using a soft wet brush and a neutral detergent. Wipe off all traces of the detergent with a clean soft damp cloth, finishing with a soft dry cloth.

Before using any fabric protector, read the manufacturer's recommendations. Some fabric protectors contain chemicals that may stain or bleach the seat material. Use a cloth dampened only with water, to clean the meter and gauge lens.

INFINITI offers vinyl and leather cleaner for

more difficult stains or soiled surfaces. See your INFINITI retailer for assistance in choosing the proper product.



CAUTION

- *Never use benzine, thinner, or any similar solvents.*
- *The leather seats should be regularly coated with a leather wax like saddle soap. Never use car wax.*
- *Never use fabric protectors unless recommended by the manufacturer.*
- *Do not use glass or plastic cleaner on meter or gauge lens covers. It may damage the lens cover.*

FLOOR MATS

The use of genuine floor mats can extend the life of your vehicle carpet and make it easier to clean the interior.

No matter what mats are used, be sure they are fitted for your vehicle and are properly positioned in the footwell to prevent interference with pedal operation.

Mats should be maintained with regular cleaning and replaced if they become excessively worn.

Floor mat positioning aid (Driver side only)

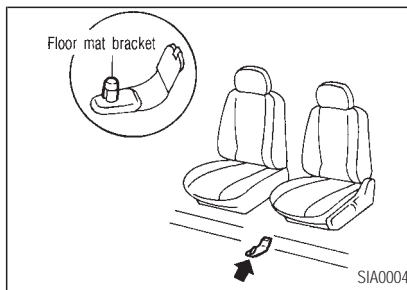

Your INFINITI model includes a front floor mat bracket to act as a floor mat positioning aid. INFINITI floor mats have been specially designed for your vehicle model. The driver's side floor mat has a grommet hole incorporated in it. Simply position the mat by placing the floor mat bracket through the floor mat grommet hole while centering the mat in the floorpan contour.

Periodically check to make certain that the

APPEARANCE AND CARE

mats are properly positioned.

SEAT BELTS

The seat belts can be cleaned by wiping them with a sponge dampened in a mild soap solution. Allow the belts to dry completely before using them.



WARNING

Do not allow wet belts to roll up in the retractor. Never use bleach, dye, or chemical solvents since these may severely weaken the seat belt webbing.

APPEARANCE AND CARE

CORROSION PROTECTION

MOST COMMON FACTORS CONTRIBUTING TO VEHICLE CORROSION

- The accumulation of moisture-retaining dirt and debris in body panel sections, cavities, and other areas.
- Damage to paint and other protective coatings caused by gravel and stone chips or minor traffic accidents.

ENVIRONMENTAL FACTORS INFLUENCE THE RATE OF CORROSION

Moisture

Accumulation of sand, dirt and water on the vehicle body underside can accelerate corrosion. Wet floor coverings will not dry completely inside the vehicle, and should be removed for drying to avoid floor panel corrosion.

Relative humidity

Corrosion will be accelerated in areas of high relative humidity, especially those areas where the temperatures stay above freezing where atmospheric pollution exists, or where road salt is used.

Temperature

A temperature increase will accelerate the rate of corrosion to those parts which are not well ventilated.

Air pollution

Industrial pollution, the presence of salt in the air in coastal areas, or heavy road salt use will accelerate the corrosion process. Road salt will also accelerate the disintegration of paint surfaces.

TO PROTECT YOUR VEHICLE FROM CORROSION

- Wash your vehicle often to keep the vehicle clean.
- Always check for minor damage to the paint and repair it as soon as possible.
- Keep drain holes at the bottom of the doors open to avoid water accumulation.
- Check the underbody for accumulation of sand, dirt or salt. If present, wash with water as soon as possible.



CAUTION

- ***Never remove dirt, sand or other debris from the passenger compartment by washing it out with a hose. Remove dirt with a vacuum cleaner or broom.***

APPEARANCE AND CARE

- *Never allow water or other liquids to come in contact with electronic components inside the vehicle as this may damage them.*
- *See your INFINITI retailer for assistance.*

Chemicals used for road surface de-icing are extremely corrosive. They accelerate corrosion and deterioration of underbody components such as the exhaust system, fuel and brake lines, brake cables, floor pan and fenders.

In winter, the underbody must be cleaned periodically.

For additional protection against rust and corrosion, which may be required in some areas, consult your local INFINITI retailer.

8 DO-IT-YOURSELF

Maintenance precautions	8-2	Windshield wiper blades.....	8-16
Engine compartment check locations	8-4	Cleaning.....	8-16
Engine cooling system	8-5	Replacing.....	8-17
Checking engine coolant level.....	8-5	Parking brake and brake pedal.....	8-18
Changing engine coolant.....	8-6	Checking parking brake.....	8-18
Engine oil	8-7	Checking brake pedal	8-18
Checking engine oil level.....	8-7	Brake booster	8-19
Changing engine oil.....	8-8	Fuses.....	8-19
Changing engine oil filter.....	8-9	Engine compartment.....	8-20
Automatic transmission fluid	8-10	Passenger compartment	8-21
Temperature conditions for		Keyfob battery replacement.....	8-21
checking	8-10	Lights	8-23
Power steering fluid	8-12	Headlights.....	8-24
Brake fluid.....	8-12	Exterior and interior lights	8-26
Window washer fluid.....	8-13	Wheels and tires.....	8-32
Battery	8-13	Tire pressure	8-32
Drive belts	8-14	Types of tires	8-33
Spark plugs	8-15	Tire chains.....	8-34
Replacing spark plugs.....	8-15	Changing wheels and tires.....	8-34
Air cleaner.....	8-16		

DO-IT-YOURSELF

MAINTENANCE PRECAUTIONS

When performing any inspection or maintenance work on your vehicle, always take care to prevent serious accidental injury to yourself or damage to the vehicle. The following are general precautions which should be closely observed.



WARNING

- *Park the vehicle on a level surface, apply the parking brake securely and block the wheels to prevent the vehicle from moving. For a manual transmission, move the shift lever to N (Neutral). For an automatic transmission, move the selector lever to P (Park).*
- *Be sure the ignition key is OFF*

or LOCK when performing any parts replacement or repairs.

- *Your vehicle is equipped with an automatic engine cooling fan. It may come on at any time without warning, even if the ignition key is in the OFF position and the engine is not running. To avoid injury, always disconnect the negative battery cable before working near the fan.*
- *If you must work with the engine running, keep your hands, clothing, hair and tools away from moving fans, belts and any other moving parts.*
- *It is advisable to secure or remove any loose clothing and any jewelry, such as rings, watches, etc. before working on your ve-*

hicle.

- *Always wear eye protection whenever you work on your vehicle.*
- *If you must run the engine in an enclosed space such as a garage, be sure there is proper ventilation for exhaust gases to escape.*
- *Never get under the vehicle while it is supported only by a jack. If it is necessary to work under the vehicle, support it with safety stands.*
- *Keep smoking materials, flame and sparks away from fuel and the battery.*
- *On gasoline engine models with the Multiport Fuel Injection (MFI) System, the fuel filter or fuel*

lines should be serviced by a INFINITI retailer because the fuel lines are under high pressure even when the engine is off.



CAUTION

- *Do not work under the hood while the engine is hot. Turn off the engine and wait until it cools down.*
- *Never connect or disconnect either the battery or any transistorized component connector while the ignition key is on.*
- *Never leave the engine or the automatic transmission related component harness connector disconnected while the ignition key is on.*

- *Avoid direct contact with used engine oil and coolant. Improperly disposed engine oil, engine coolant, and/or other vehicle fluids can hurt the environment. Always conform to local regulations for disposal of vehicle fluid.*

This “8. Do-it-yourself” section gives instructions regarding only those items which are relatively easy for an owner to perform.

More involved service should be done by your INFINITI retailer.

A genuine INFINITI Service Manual is also available. See “Owner’s Manual/Service Manual order information” in the “10. Technical and Consumer Information” section.

You should be aware that incomplete or improper servicing may result in operating difficulties or excessive emissions, and could

DO-IT-YOURSELF

affect your warranty coverage. **If in doubt about any servicing, have it done by your INFINITI retailer.**

DO-IT-YOURSELF

ENGINE COMPARTMENT CHECK LOCATIONS

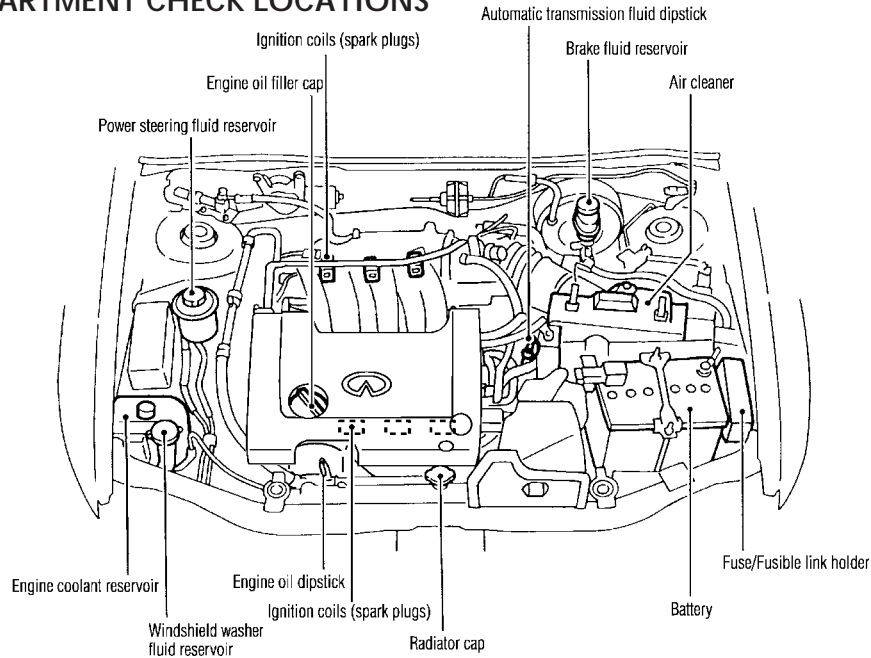

SID0251

DO-IT-YOURSELF

ENGINE COOLING SYSTEM

The engine cooling system is filled at the factory with a high-quality, year-round, anti-freeze coolant solution. The anti-freeze solution contains rust and corrosion inhibitors, therefore additional cooling system additives are not necessary.



CAUTION

When adding or replacing coolant, be sure to use only a genuine NISSAN anti-freeze coolant or equivalent with the proper mixture ratio of 50% anti-freeze and 50% demineralized water/distilled water. The use of other types of coolant solutions may damage your engine cooling system.

Outside temperature down to		Anti-freeze	Demineralized water/ distilled water
°C	°F		
-35	-30	50%	50%



WARNING

- *Never remove the radiator cap when the engine is hot. Serious burns could be caused by high pressure fluid escaping from the radiator. Wait until the engine and radiator cool down.*
- *See “If your vehicle overheats” in the “6. In case of emergency” section.*
- *The radiator is equipped with a pressure cap. To prevent engine damage, use only a genuine NISSAN radiator cap.*

CHECKING ENGINE COOLANT LEVEL

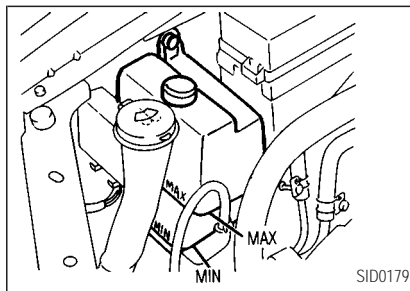

Check the coolant level in the reservoir tank when the engine is cold. If the coolant level is below MIN, add coolant up to the MAX level. If the reservoir tank is empty, check the coolant level in the radiator **when the engine is cold**. If there is insufficient coolant in the radiator, fill the radiator with coolant up to the filler opening and also add it to the reservoir tank up to the MAX level.

If the cooling system frequently requires

DO-IT-YOURSELF

coolant, have it checked by your INFINITI retailer.

CHANGING ENGINE COOLANT

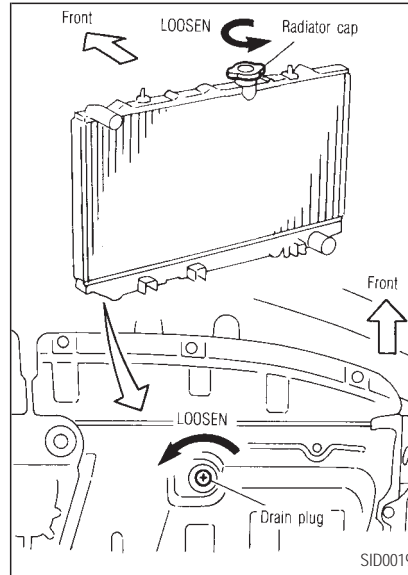

- Major cooling system repairs should be

performed by your INFINITI retailer. The service procedures can be found in the appropriate INFINITI Service Manual.

- Improper servicing can result in reduced heater performance and engine overheating.



WARNING

- *To avoid being scalded, never change the coolant when the engine is hot.*
- *Never remove the radiator cap when the engine is hot. Serious burns could be caused by high pressure fluid escaping from the radiator.*
- *Avoid direct skin contact with used coolant. If skin contact is made, wash thoroughly with soap*

DO-IT-YOURSELF

or hand cleaner as soon as possible.

- **Keep coolant out of reach of children and pets.**

1. Perform the following procedure to open the heater water cock.
 - Turn the ignition key from OFF to ON.
 - Move the heater or air conditioner temperature control dial to the maximum hot position then turn the ignition key to OFF.
2. Open radiator drain valve at the bottom of radiator, and remove radiator filler cap.
 - **Be careful not to allow coolant to contact drive belts.**
 - **Waste coolant must be disposed of properly. Check your local regulations.**

3. Close the radiator drain valve securely after the coolant is drained.
4. Fill the radiator slowly with the proper mixture of anti-freeze solution and demineralized water/distilled water. Fill the reservoir tank up to the MAX level. Then install the radiator filler cap.
5. Start the engine and warm it up until it reaches normal operating temperature. Then race the engine 2 or 3 times under no load. Watch the engine coolant temperature gauge for signs of overheating.
6. Stop the engine. After it completely cools down, refill the radiator up to the filler opening. Fill the reservoir tank up to the MAX level. Check the drain valve for any sign of leakage.
7. Recheck the coolant level after the vehicle has been driven for a day.

ENGINE OIL

CHECKING ENGINE OIL LEVEL

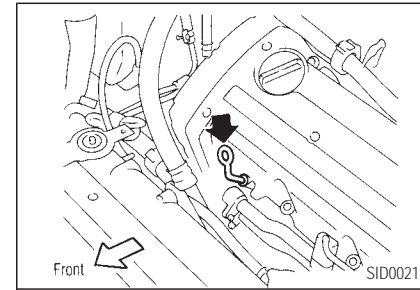

1. Park the vehicle on a level surface and apply parking brake.
2. Run the engine until it reaches operating temperature.
3. Turn off the engine. **Wait more than 10 minutes for the oil to drain back into the oil pan.**

DO-IT-YOURSELF

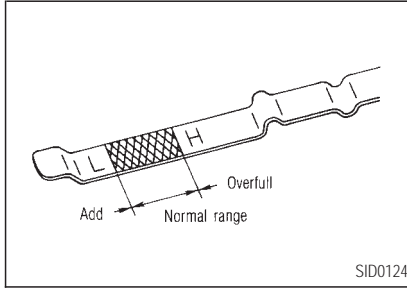

4. Remove the dipstick and wipe it clean. Reinsert it all the way.
5. Remove the dipstick again and check the oil level. It should be between the H and L marks. If the oil level is below the L mark, remove the oil filler cap and pour recommended oil through the opening. **Do not overfill.**
6. Recheck oil level with dipstick.

It is normal to add some oil between oil maintenance intervals or during the

break-in period, depending on the severity of operating conditions.



Oil level should be checked regularly. Operating with insufficient amount of oil can damage the engine, and such damage is not covered by warranty.

CHANGING ENGINE OIL

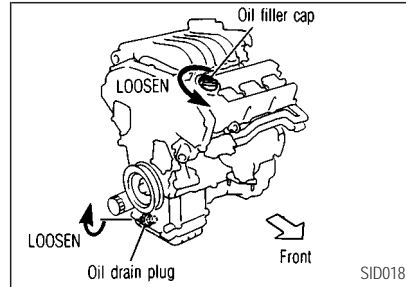

1. Park the vehicle on a level surface and apply the parking brake.
2. Run the engine until it reaches operating temperature.
3. Turn the engine off and wait more than 10 minutes.
4. Place a large drain pan under the drain plug.
5. Remove the oil filler cap.
6. Remove the drain plug with a wrench and completely drain the oil.

If oil filter is to be changed, remove and replace it at this time. See later in "Engine oil" for changing engine oil filter.



Be careful not to burn yourself, as the engine oil is hot.

DO-IT-YOURSELF

- **Waste oil must be disposed of properly.**
 - **Check your local regulations.**
7. Clean and re-install the drain plug with a new washer. Securely tighten the drain plug with a wrench.

Drain plug tightening torque:

**22 to 29 ft-lb
(29 to 39 N·m)**

Do not use excessive force.

8. Refill engine with recommended oil and install the cap securely.

See “Capacities and recommended fuel/lubricants” in the “10. Technical and consumer information” section for drain and refill capacity.

The drain and refill capacity depends on the oil temperature and drain time. Use these specifications for reference only. Always use the dipstick to determine the

- proper amount of oil in the engine.
9. Start the engine.
Check for leakage around the drain plug. Correct as required.
10. Turn the engine off and wait more than 10 minutes. Check the oil level with the dipstick. Add engine oil if necessary.
11. Dispose waste oil properly.



WARNING

- ***Prolonged and repeated contact with used engine oil may cause skin cancer.***
- ***Try to avoid direct skin contact with used oil. If skin contact is made, wash thoroughly with soap or hand cleaner as soon as possible.***

- ***Keep used engine oil out of reach of children.***

CHANGING ENGINE OIL FILTER

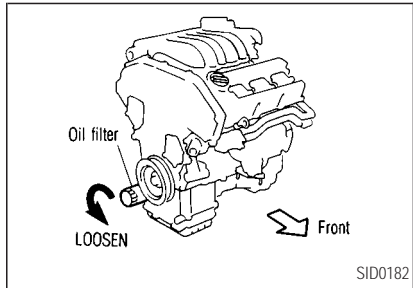

SID0182

1. Park the vehicle on a level surface and apply the parking brake.
2. Turn the engine off.
3. Loosen the oil filter with an oil filter wrench. (Depending on the engine model,

DO-IT-YOURSELF

a special **cap type** wrench may be required. See your INFINITI retailer if in doubt.) Remove the oil filter by turning it by hand.



CAUTION

Be careful not to burn yourself, as the engine oil may be hot.

4. Wipe the engine oil filter mounting surface with a clean rag.

Be sure to remove any old rubber gasket remaining on the mounting surface of the engine.

5. Coat the rubber gasket on the new filter with clean engine oil.
6. Screw in the oil filter until a slight resistance is felt, then tighten additionally more than 2/3 turn.

Oil filter tightening torque:

**10.85 to 15.19 ft-lb
(14.7 to 20.6 N·m)**

7. Start the engine and check for leakage around the oil filter. Correct as required.
8. Turn the engine off and wait several minutes. Check the oil level. Add engine oil if necessary.

AUTOMATIC TRANSMISSION FLUID



WARNING

- ***When engine is running, keep hands, jewelry and clothing away from any moving parts such as cooling fan and drive belt.***
- ***Automatic transmission fluid is poisonous and should be stored***

carefully in marked containers out of the reach of children.

TEMPERATURE CONDITIONS FOR CHECKING

- The fluid level should be checked using the HOT range on the dipstick after the following conditions have been met:
 - a) the engine should be warmed up to operating temperature.
 - b) the vehicle should be driven at least 5 minutes.
 - c) the automatic transmission fluid should be warmed to between 122 and 176°F (50 and 80°C).
- The fluid can be checked at fluid temperatures of 86 to 122°F (30 to 50°C) using the COLD range on the dipstick after the engine is warmed up and before driving.

DO-IT-YOURSELF

However, the fluid should be re-checked using the HOT range.

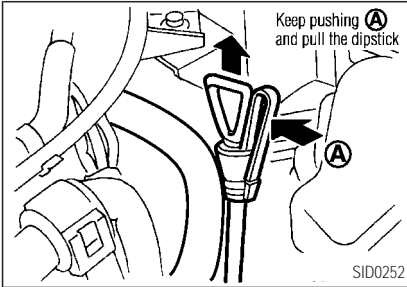

1. Park the vehicle on a level surface and set the parking brake.
2. Start the engine and then move the selector lever through each gear range. Move the selector lever to the P (Park) position after you have moved it through all ranges.

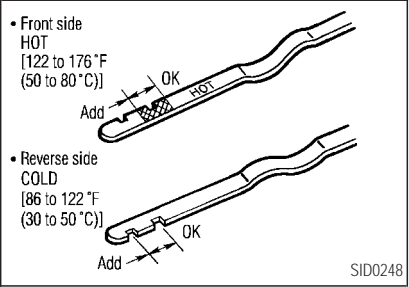

3. Check the fluid level with the engine idling.
4. Remove the dipstick and wipe it clean with lint-free paper.
5. Reinsert the dipstick into the charging pipe as far as it will go.
6. Remove the dipstick and note the reading. If the level is at the low side of either range, add fluid to the charging pipe.

CAUTION

- Do not overfill.
- Use only NISSAN Matic D (Continental US and Alaska) or Canada Nissan automatic transmission fluid. Dexron™ III/Mercon™ or equivalent may also be used. Outside the continental US and Alaska contact an INFINITI retailer for more information regarding suitable fluids, including recommended brand(s) of Dexron™ III/Mercon™ automatic transmission fluid.

If the vehicle has been driven for a long time at high speeds, or in city traffic in hot weather, or if it is being used to pull a trailer, the accurate fluid level cannot

DO-IT-YOURSELF

be read. You should wait until the fluid has cooled down (about 30 minutes).

POWER STEERING FLUID

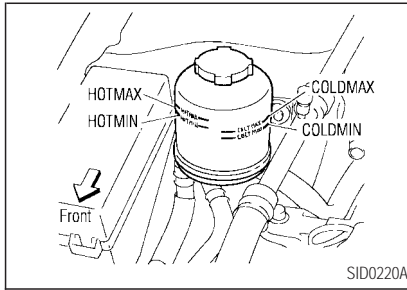

Check the fluid level in the reservoir tank.

The fluid level should be checked using the HOT range at fluid temperatures of 122 to 176°F (50 to 80°C) or using the COLD range at fluid temperatures of 32 to 86°F (0 to 30°C).



CAUTION

- Do not overfill.
- Use Genuine Nissan PSFII or equivalent.

BRAKE FLUID

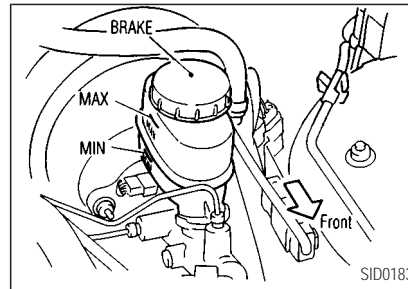

Check the fluid level in the reservoir. If the fluid is below the MIN line or the brake warning light comes on, add **DOT 3** fluid up

to the MAX line. If fluid must be added frequently, the system should be thoroughly checked by your INFINITI retailer.



WARNING

Use only new fluid. Old, inferior, or contaminated fluid may damage the brake systems. The use of improper fluids can damage the brake system and affect the vehicle's stopping ability.



CAUTION

Do not spill the fluid on painted surfaces. This will damage the paint. If fluid is spilled, wash with water.

DO-IT-YOURSELF

WINDOW WASHER FLUID

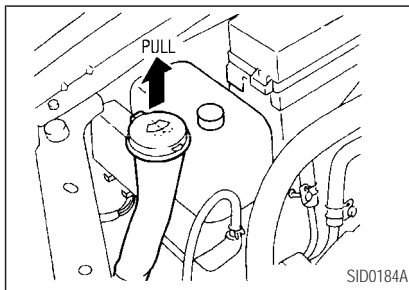

Add fluid when the low washer fluid warning light comes on. Add a washer solvent to the water for better cleaning. In the winter season, add a windshield washer anti-freeze. Follow the manufacturer's instructions for the mixture ratio.



Anti-freeze is poisonous and should

be stored carefully in marked containers out of the reach of children.



Do not substitute engine anti-freeze coolant for window washer solution. This may result in damage to the paint.

BATTERY

- Keep the battery surface clean and dry. Any corrosion should be washed off with a solution of baking soda and water.
- Make certain the terminal connections are clean and securely tightened.
- If the vehicle is not to be used for 30 days or longer, disconnect the (—) negative battery terminal cable to prevent discharging it.



- *Do not expose the battery to flames or electrical sparks. Hydrogen gas generated by battery action is explosive. Do not allow battery fluid to contact your skin, eyes, fabrics, or painted surfaces. After touching a battery or battery cap, do not touch or rub your eyes. Thoroughly wash your hands. If the acid contacts your eyes, skin or clothing, immediately flush with water for at least 15 minutes and seek medical attention.*
- *When working on or near a battery, always wear suitable eye protection and remove all jewelry.*

DO-IT-YOURSELF

- **Battery posts, terminals and related accessories contain lead and lead compounds. Wash hands after handling.**
- **Keep the battery out of the reach of children.**

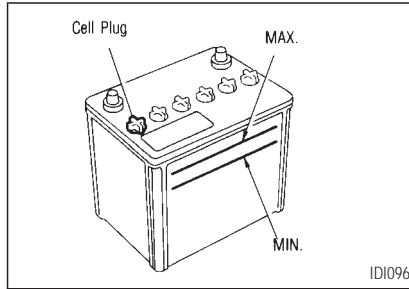

Check the fluid level in each cell. It should be between the MAX. and MIN. lines.

If it is necessary to add fluid, add only distilled water to bring the level to the

indicator in each filler opening. **Do not overfill.**

1. Remove the cell plugs.
2. Add distilled water up to the MAX. level.
3. Tighten cell plugs.

Vehicle operated in high temperatures or under severe conditions require frequent checks of the battery fluid level.

If jump starting is necessary, see "Jump starting" in the "6. In case of emergency" section. If the engine does not start by jump starting, the battery may have to be replaced. Contact your INFINITI retailer.

DRIVE BELTS

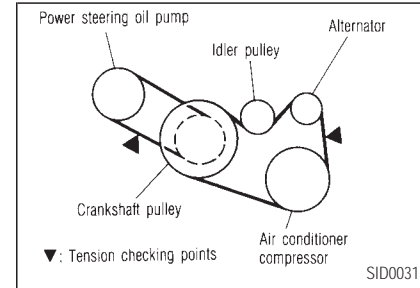

WARNING

Be sure the ignition key is in the OFF or LOCK position. The engine could rotate unexpectedly.

1. Visually inspect each belt for signs of unusual wear, cuts, fraying, oil adhesion or looseness. If the belt is in poor condi-

tion or loose, have it replaced or adjusted by your INFINITI retailer.

2. Have the belts checked regularly for condition and tension in accordance with the maintenance schedule in this manual.

SPARK PLUGS



WARNING

Be sure the engine and ignition switch are off and that the parking brake is engaged securely.



CAUTION

Be sure to use the correct socket to remove the spark plugs. An incorrect socket can damage the spark plugs.

DO-IT-YOURSELF

REPLACING SPARK PLUGS

Platinum-tipped spark plugs

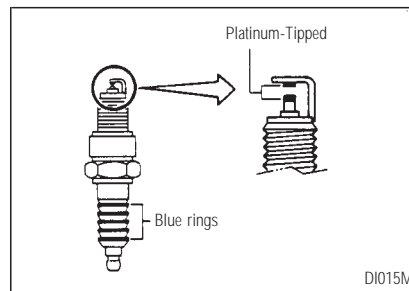

It is not necessary to replace the platinum-tipped spark plugs as frequently as the conventional type spark plugs since they will last much longer. Follow the maintenance schedule but, do not reuse them by cleaning or regapping.

If replacement is required, see your INFINITI dealer for servicing.

Always replace with recommended

DO-IT-YOURSELF

platinum-tipped spark plugs.

AIR CLEANER

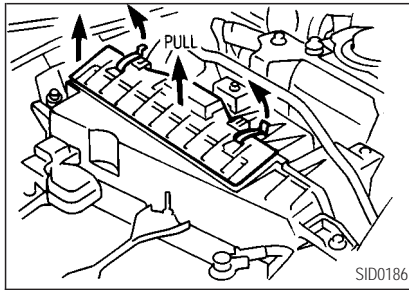

The filter element should not be cleaned and reused. Replace it according to the maintenance intervals. See "Periodic maintenance schedules" in the "9. Maintenance" section for maintenance intervals. When replacing the filter, wipe the inside of the air cleaner housing and the cover with a damp cloth.

WARNING

- *Operating the engine with the air cleaner removed can cause you or others to be burned. The air cleaner not only cleans the air, it stops flame if the engine backfires. If it is not there, and the engine backfires, you could be burned. Do not drive with the air cleaner removed, and be careful working on the engine with the air cleaner removed.*
- *Never pour fuel into the throttle body or attempt to start the engine with the air cleaner removed. Doing so could result in serious injury.*

WINDSHIELD WIPER BLADES

CAUTION

- *After wiper blade replacement, return the wiper arm to its original position.*
- *Otherwise it may be damaged when the engine hood is opened. Make sure the wiper blade contacts the glass, otherwise the arm may be damaged from wind pressure.*
- *Worn windshield wiper blades can damage the windshield and impair driver vision.*

CLEANING

If your windshield is not clear after using the

DO-IT-YOURSELF

windshield washer or if a wiper blade chatters when running, wax or other material may be on the blade or windshield.

Clean the outside of the windshield with a washer solution or a mild detergent. Your windshield is clean if beads do not form when rinsing with clear water.

Clean the blade by wiping it with a cloth soaked in a washer solution or a mild detergent. Then rinse the blade with clear water. If your windshield is still not clear after cleaning the blades and using the wiper, replace the blades.

REPLACING

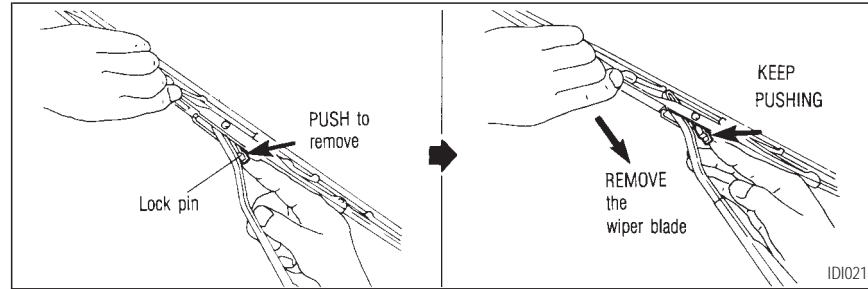

Replace the wiper blades if they are worn.

1. Pull the wiper arm.
2. Push the lock pin, then remove the wiper blade.
3. Insert the new wiper blade to the wiper arm until a click sounds.

DO-IT-YOURSELF

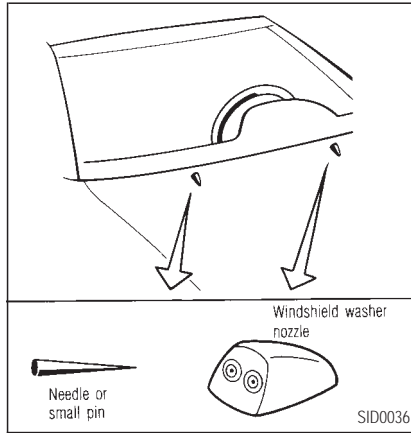

If you wax the surface of the hood, be careful not to let wax get into the washer nozzle. This may clog the nozzle that could cause or improper windshield washer operation. If wax gets into the nozzle, unplug it with a needle or small pin.

PARKING BRAKE AND BRAKE PEDAL

CHECKING PARKING BRAKE

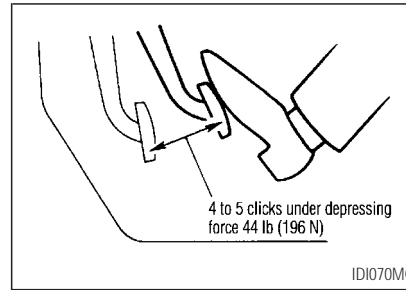

From the released position, depress the parking brake pedal slowly and firmly. If the number of clicks is out of the range shown above, see your INFINITI retailer.

CHECKING BRAKE PEDAL

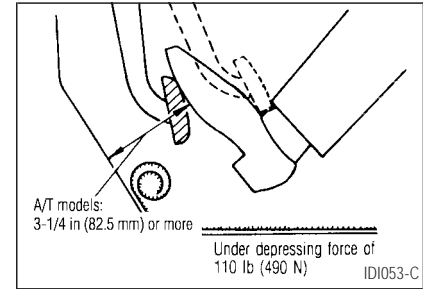

With the engine running, check the distance between the upper surface of the pedal and the metal floor. If it is out of the range shown above, see your INFINITI retailer.

Self-adjusting brakes

Your vehicle is equipped with self-adjusting brakes.

The disc-type brakes self-adjust every time the brake pedal is applied.



WARNING

See your INFINITI retailer and have it checked if the brake pedal height does not return to normal.

Brake pad wear indicators

The disc brake pads on your vehicle have audible wear indicators. When a brake pad requires replacement, it will make a high pitched scraping or screeching sound when the vehicle is in motion whether or not the brake pedal is depressed. Have the brakes checked as soon as possible if the wear indicator sound is heard.

Under some driving or climate conditions, occasional brake squeak, squeal or other noise may be heard. Occasional brake noise during light to moderate stops is normal and

does not affect the function or performance of the brake system.

Proper brake inspection intervals should be followed. For additional information, see “Periodic maintenance schedules” in the “9. Maintenance” section for maintenance intervals.

BRAKE BOOSTER

Check the brake booster function as follows:

1. With the engine off, press and release the brake pedal several times. When brake pedal movement (distance of travel) remains the same from one pedal application to the next, continue on to the next step.
2. While depressing the brake pedal, start the engine. The pedal height should drop a little.
3. With the brake pedal depressed, stop the engine. Keeping the pedal depressed for

DO-IT-YOURSELF

about 30 seconds, the pedal height should not change.

4. Run the engine for 1 minute without depressing the brake pedal, then turn it off. Depress the brake pedal several times. The pedal travel distance will decrease gradually with each depression as the vacuum is released from the booster.

If the brakes do not operate properly, see your INFINITI retailer.

FUSES



CAUTION

Never use a fuse of higher amperage rating than that specified on the fuse box cover. This could damage the electrical system or cause a fire.

DO-IT-YOURSELF

ENGINE COMPARTMENT

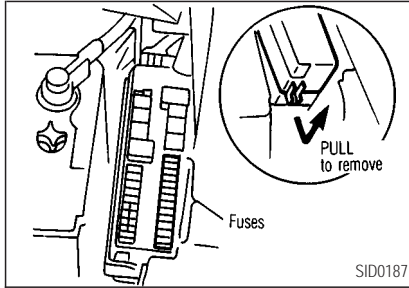

If any electrical equipment does not operate, check for an open fuse.

1. Be sure the ignition key and headlight switch are OFF.
2. Open the engine hood.
3. Remove the fusible link cover.
4. Remove the fuse with the fuse puller.
5. If the fuse is open, replace it with a new fuse.

8-20

6. If a new fuse also opens, have the electrical system checked and repaired by your INFINITI retailer.

Fusible links

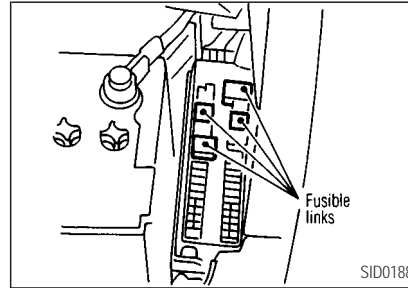

If the electrical equipment does not operate and fuses are in good condition, check the fusible links. If any of these fusible links are melted, replace only with genuine INFINITI parts.

DO-IT-YOURSELF

PASSENGER COMPARTMENT

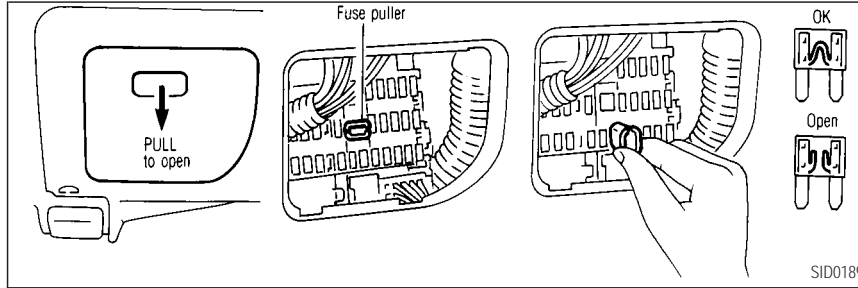

If any electrical equipment does not operate, check for an open fuse.

1. Be sure the ignition key and headlight switch are OFF.
2. Open the fuse box lid.
3. Remove the fuse with the fuse puller.
4. If the fuse is open, replace it with a new fuse.
5. If a new fuse also opens, have the electrical system checked and repaired by your INFINITI retailer.

KEYFOB BATTERY REPLACEMENT

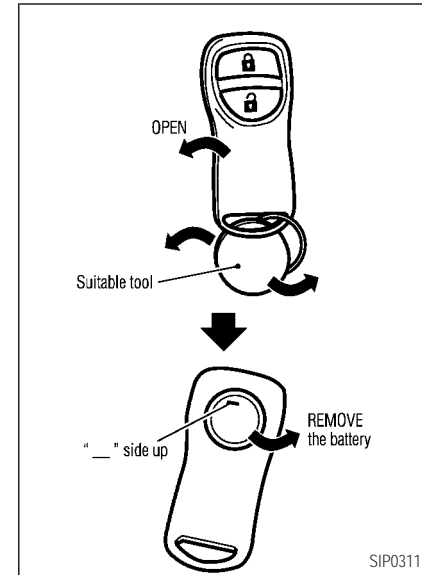

DO-IT-YOURSELF

Replace the battery as follows:

1. Open the lid using a suitable tool.
2. Replace the battery with a new one.
Recommended battery: Sanyo CR2025 or equivalent

Make sure that the ⊕ side faces the bottom case.

3. Close the lid securely.
4. Push the keyfob button two or three times to check its operation.

See your INFINITI retailer if you need any assistance for replacement.

If the battery is removed for any reason other than replacement, perform step 4 above.

- **An improperly disposed battery can harm the environment. Always confirm local regulations for battery disposal.**

- **The keyfob is water-proof; however, if it does get wet, immediately wipe completely dry.**
- **When changing batteries, do not let dust or oil get on the controller.**

FCC Notice:

Changes or modifications not expressly approved by the manufacturer compliance could void the user's authority to operate the equipment.

This device complies with Part 15 of the FCC Rules and RSS-210 of Industry Canada.

Operation is subject to the following two conditions: (1) This device may not cause harmful interference, and (2) this device must accept any interference received, including interference that may cause undesired operation of the device.

LIGHTS

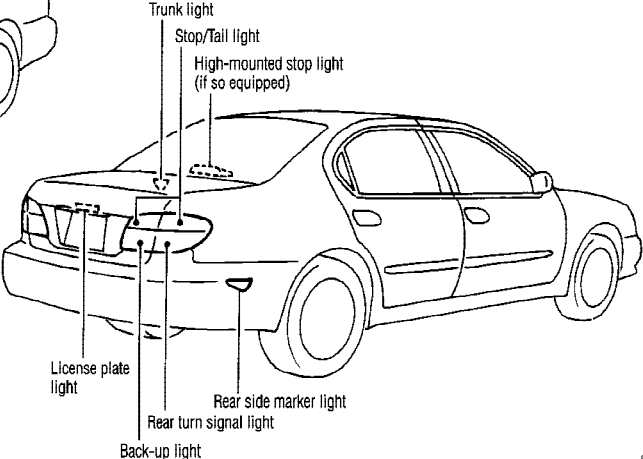
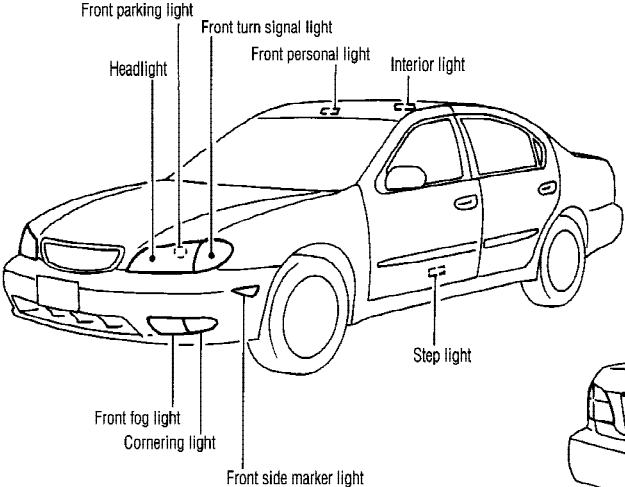

SID0253A

DO-IT-YOURSELF

HEADLIGHTS

Replacing the xenon headlight bulb (Low beam)

 **WARNING**

 **HIGH VOLTAGE**

When xenon headlights are on, they produce a high voltage. To prevent an electric shock, never attempt to modify or disassemble. Always have your xenon headlights replaced at an authorized INFINITI retailer. For additional information, see “Headlight and turn signal switch” in the “2. Instruments and controls” section.

Replacing the halogen headlight bulb (High beam)

The headlight is a semi-sealed beam type which uses replaceable headlight (halogen)

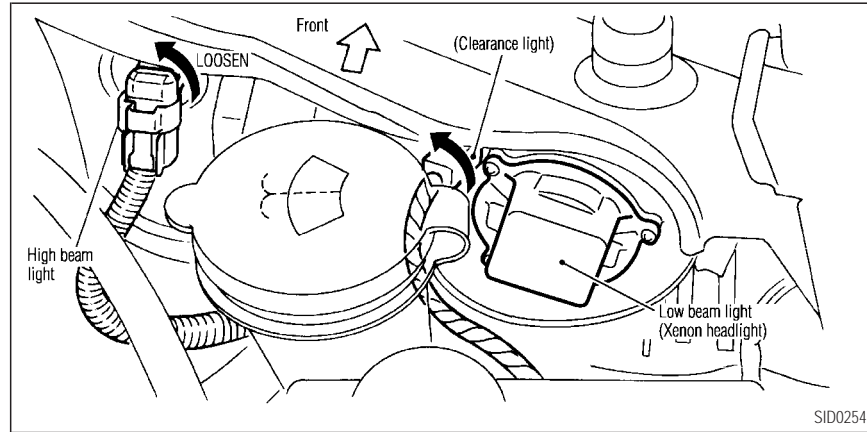

SID0254

bulbs. They can be replaced from inside the engine compartment without removing the headlight assembly.

 **CAUTION**

- High pressure halogen gas is

sealed inside the bulb. The bulb may break if the glass envelope is scratched or the bulb is dropped.

- Hold the plastic base when handling the bulb. Never touch the glass envelope.

DO-IT-YOURSELF

- **Use the same number and wattage as originally installed:**

*High beam bulb 60W - HB3
Low beam (Xenon) See an authorized INFINITI retailer to replace the xenon headlights.*

- **Do not leave the bulb out of the headlight reflector for a long period of time as dust, moisture, and smoke may enter the headlight body and affect the performance of the headlight.**

1. Open the engine hood.
2. Disconnect the battery negative cable.
3. Turn the bulb connector counterclockwise, then remove it.
4. Remove the headlight bulb. Do not shake or rotate the bulb when removing it.

5. Install the new bulb in the reverse order of removal.

Aiming is not necessary after the bulb has been replaced. When aiming adjustment is necessary, contact your INFINITI retailer.

DO-IT-YOURSELF

EXTERIOR AND INTERIOR LIGHTS

Item	Wattage (W)	Bulb No.
Turn signal	21	T20
Front parking light	5	T10
Side marker lights (Front, Rear)	3.8	T10
Front fog light	See an authorized INFINITI retailer for assistance.	
Cornering light		
Rear combination light		
Turn signal	21	T20
Stop/Tail	21/5	T20
Back-up	18	T16
License plate light	5	T10
High-mounted stop light (1-lamp type)	21	T20
High-mounted stop light (5-lamp type)	5	T10
Interior light	10	
Front personal light	10	
Step light	2.7	161
Trunk light	3.4	158
Vanity mirror light	1.4	

Replacement procedures

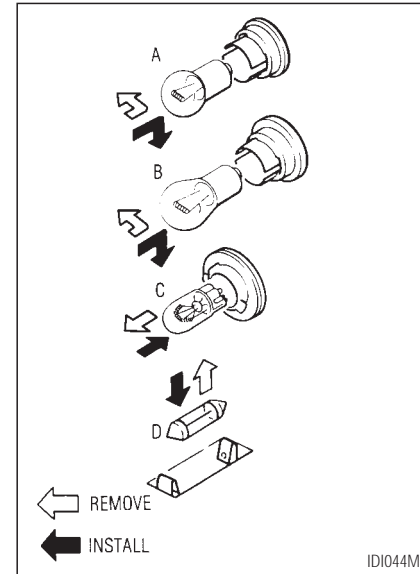

All other lights are either type A, B, C or D.

DO-IT-YOURSELF

When replacing a bulb, first remove the lens and/or cover.

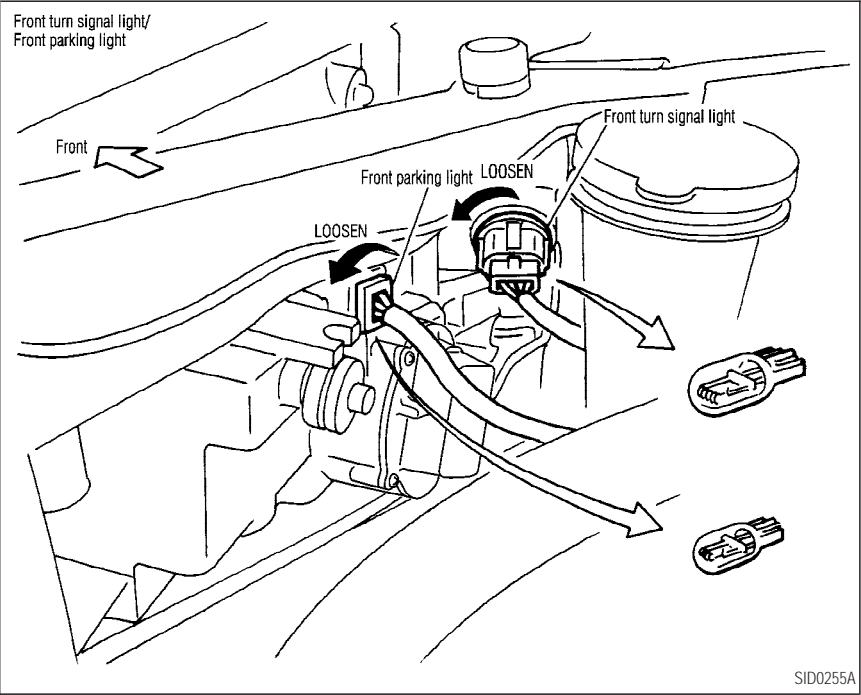

DO-IT-YOURSELF

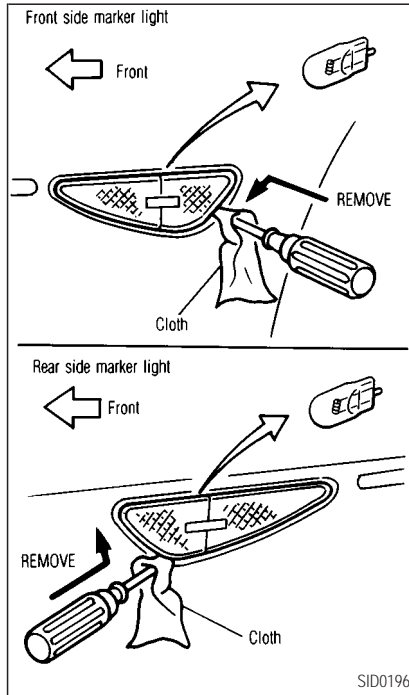

DO-IT-YOURSELF

Rear combination light (Trunk side)

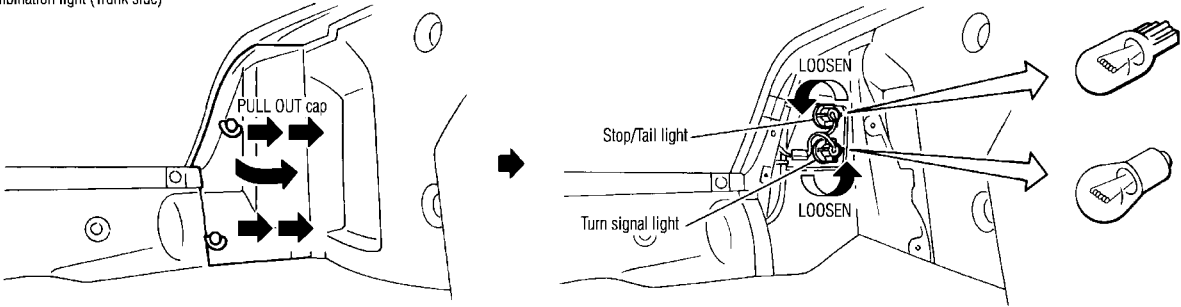

(Trunk lid side)

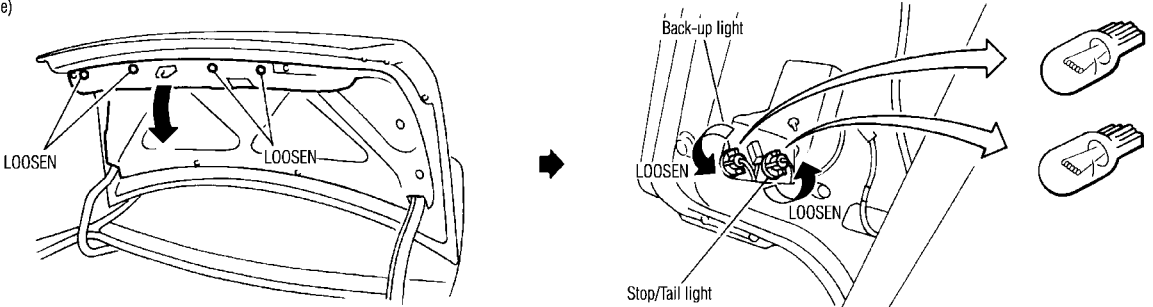

SID0256

DO-IT-YOURSELF

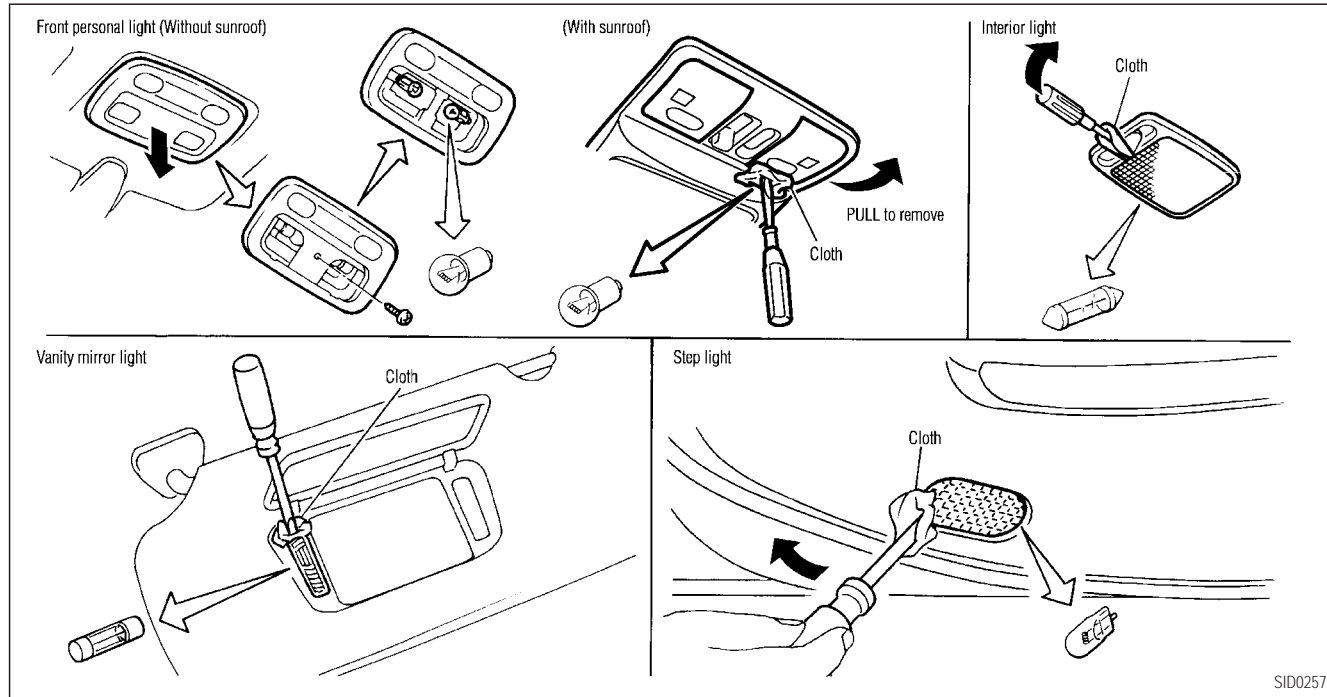

SID0257

DO-IT-YOURSELF

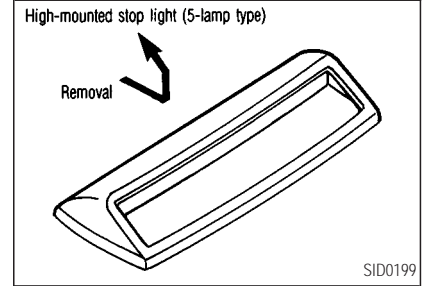
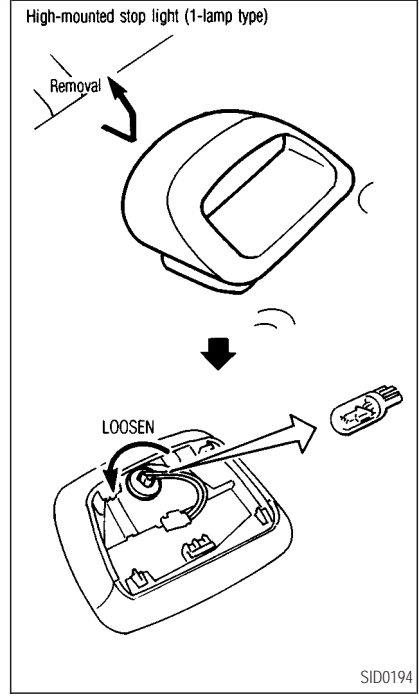
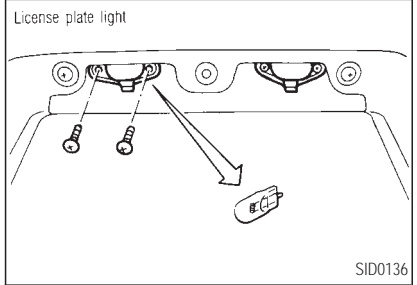
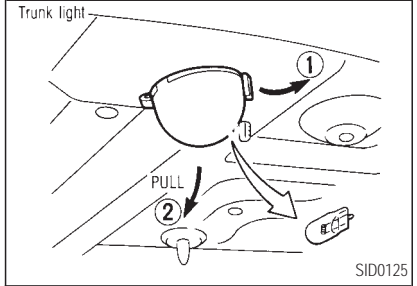

DO-IT-YOURSELF

WHEELS AND TIRES

If you have a flat tire, see “Flat tire” in the “6. In case of emergency” section.

TIRE PRESSURE

Maximum inflation pressure

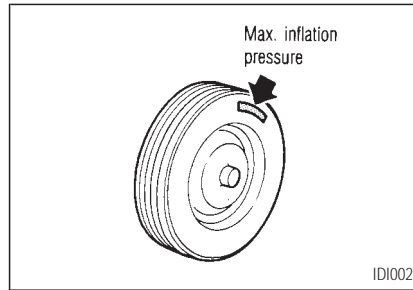

Do not exceed the maximum inflation pressures shown on the side wall of the tire.

Tire inflation pressure

Check the tire pressure (including spare) at least once a month and always prior to long distance trips. Incorrect tire pressure may

adversely affect tire life and vehicle handling. Tire pressure should be checked when tires are COLD. Tires are considered COLD after the vehicle has been parked for 3 or more hours, or driven less than 1 mile (1.6 km). COLD tire pressures are shown on the tire placard affixed to the center console lid.



WARNING

- *Improperly inflated tires can fail suddenly and cause an accident.*
- *The vehicle capacity weight is indicated on the tire placard. Do not load your vehicle beyond this capacity. Overloading your vehicle may result in reduced tire life, unsafe operating conditions due to premature tire failure, or unfavorable handling characteristics and could also lead to a serious accident. Loading beyond*

the specified capacity may also result in failure of other vehicle components.

- *Before taking a long trip, or whenever you have loaded your vehicle heavily, use a tire pressure gauge to ensure that the tire pressure is at the specified level.*
- *Do not drive your vehicle over 85 MPH (140 km/h) unless it is equipped with high speed capability tires. Driving faster than 85 MPH (140 km/h) may result in tire failure, loss of control and possible injury.*
- *For additional information regarding tires, refer to “Important Tire Safety Information” (US) or “Tire Safety Information” (Canada) in the INFINITI Warranty Information booklet.*

DO-IT-YOURSELF

TYPES OF TIRES



CAUTION

- *When changing or replacing tires, be sure all four tires are of the same type (i.e., summer, all season or snow) and construction. Your INFINITI retailer may be able to help you with information about tire type, size, speed rating and availability. Replacement tires may have a lower speed rating than the factory equipped tires, and may not match the potential maximum vehicle speed. Never exceed the maximum speed rating of the tire.*
- *For additional information regarding tires, refer to “Important Tire Safety Information” (US) or “Tire Safety Information” (Canada) in the INFINITI Warranty Information booklet.*

All season tires

INFINITI specifies all season tires on some models to provide good performance for use all year around, including snowy and icy road conditions. All season tires are identified by ALL SEASON and/or M&S on the tire sidewall. Snow tires have better snow traction than all season tires and may be more appropriate in some areas.

Summer tires

INFINITI specifies summer tires on some models to provide superior performance on dry roads. Summer tire performance in snow and ice will be substantially reduced. Summer tires do not have the tire traction rating M&S on the tire sidewall.

If you operate your vehicle in snowy or icy conditions, INFINITI recommends the use of snow or all season tires on all four wheels.

Snow tires

If snow tires are needed, it is necessary to select tires equivalent in size and load rating to the original equipment tires. If you do not, it can adversely affect the safety and handling of your vehicle.

Generally, snow tires will have lower speed ratings than factory equipped tires and may not match the potential maximum vehicle speed. Never exceed the maximum speed rating of the tire.

If you operate your vehicle in snowy or icy conditions, INFINITI recommends the use of snow or all season tires on all four wheels.

For additional traction on icy roads, studded tires may be used. However, some provinces and states prohibit their use. Check local, state and provincial laws before installing studded tires. Skid and traction capabilities of studded snow tires, on wet or dry surfaces, may be poorer than that of non-studded snow tires.

DO-IT-YOURSELF

TIRE CHAINS

Use of tire chains may be prohibited according to location. Check the local laws before installing tire chains. When installing tire chains, make sure they are of proper size for the tires on your vehicle and are installed according to the chain manufacturer's suggestions. **Use only SAE class S chains.** Class "S" chains are used on vehicles with restricted tire to vehicle clearance. Vehicles that can use Class "S" chains are designed to meet the SAE standard minimum clearances between the tire and the closest vehicle suspension or body component required to accommodate the use of a winter traction device (tire chains or cables). The minimum clearances are determined using the factory equipped tire size. Other types may damage your vehicle. Use chain tensioners when recommended by the tire chain manufacturer to ensure a tight fit. Loose end links of the tire chain must be secured or removed to prevent the possibility of whipping action dam-

age to the fenders or undercarriage. If possible, avoid fully loading your vehicle when using tire chains. In addition, drive at a reduced speed. Otherwise, your vehicle may be damaged and/or vehicle handling and performance may be adversely affected.

Never install tire chains on a T-type spare tire. Do not use tire chains on dry roads.

CHANGING WHEELS AND TIRES

Tire rotation

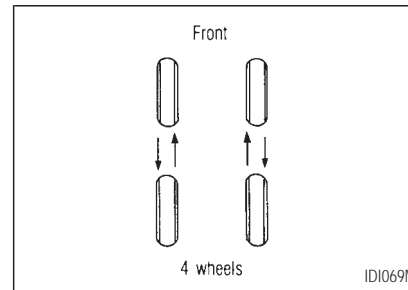

INFINITI recommends that tires be rotated every 7,500 miles (12,000 km).

Wheel nut tightening torque:

80 ft-lb (108 N·m)

See "Flat tire" in the "6. In case of emergency" section for tire replacing procedures.



WARNING

- *After rotating the tires, adjust the tire pressure.*
- *Retighten the wheel nuts when the vehicle has been driven for 600 miles (1,000 km) (also in cases of a flat tire, etc.).*
- *Do not include the T-type spare tire or any other small size spare tire in the tire rotation.*
- *For additional information regarding tires, refer to "Important Tire Safety Information" (US) or*

“Tire Safety Information” (Canada) in the INFINITI Warranty Information booklet.

Tire wear and damage

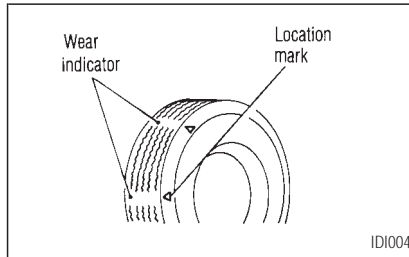

WARNING

- *Tires should be periodically inspected for wear, cracking, bulg-*

ing, or objects caught in the tread. If excessive wear, cracks, bulging, or deep cuts are found, the tire should be replaced.

- *The original tires have a built-in tread wear indicator. When the wear indicator is visible, the tire should be replaced.*
- *Improper service for a T-type spare tire may result in serious personal injury. If it is necessary to repair the T-type spare tire, contact your INFINITI retailer.*
- *For additional information regarding tires, refer to “Important Tire Safety Information” (US) or “Tire Safety Information” (Canada) in the INFINITI Warranty Information booklet.*

DO-IT-YOURSELF

Replacing wheels and tires

When replacing a tire, use the same size, speed rating and load carrying capacity as originally equipped. See “Specifications” in the “10. Technical and consumer information” section for recommended types and sizes of tires and wheels.



WARNING

- *The use of tires other than those recommended or the mixed use of tires of different brands, construction (bias, bias-belted or radial), or tread patterns can adversely affect the ride, braking, handling, ground clearance, body-to-tire clearance, tire chain clearance, speedometer calibration, headlight aim and bumper height.*

DO-IT-YOURSELF

Some of these effects may lead to accidents and could result in serious personal injury.

- *If the wheels are changed for any reason, always replace with wheels which have the same offset dimension. Wheels of a different offset could cause early tire wear, possibly degraded vehicle handling characteristics and/or interference with the brake discs. Such interference can lead to decreased braking efficiency and/or early brake pad wear.*
- *Do not install a deformed wheel or tire even if it has been repaired. Such wheels or tires could have structural damage and could fail without warning.*

- ***The use of retread tire is not recommended.***
- ***For additional information regarding tires, refer to “Important Tire Safety Information” (US) or “Tire Safety Information” (Canada) in the INFINITI Warranty Information booklet.***

Wheel balance

Unbalanced wheels may affect vehicle handling and tire life. Even with regular use, wheels can get out of balance. Therefore, they should be balanced as required.

Wheel balance service should be performed with the wheels off the vehicle. Spin balancing the front wheels on the vehicle could lead to transmission damage.

Care of wheels

- Wash the wheels when washing the vehicle to maintain their appearance.

- Clean the inner side of the wheels when the wheel is changed or the underside of the vehicle is washed.
- Do not use abrasive cleaners when washing the wheels.
- Inspect wheel rims regularly for dents or corrosion. Such damage may cause loss of pressure or poor seal at the tire bead.
- INFINITI recommends that the road wheels be waxed to protect against road salt in areas where it is used during winter.

Spare tire (T-type spare tire)

US only. Canadian vehicles are equipped with a full size spare tire.

Observe the following precautions if the T-type spare tire must be used, otherwise your vehicle could be damaged or involved in an accident.

DO-IT-YOURSELF



WARNING

- *The T-type spare tire should be used only for emergency. It should be replaced by the standard tire at the first opportunity.*
- *Drive carefully while the T-type spare tire is installed.*
Avoid sharp turns and abrupt braking while driving.
- *Periodically check the T-type spare tire inflation pressure, and always keep it at 60 psi (420 kPa, 4.2 bar).*
- *Always keep the pressure of the full size spare tire (if so equipped) at the recommended pressure for standard tires, as indicated on the tire placard. For*

tire placard location, see “Tire placard” in the “10. Technical and consumer information”.

- *Do not drive your vehicle at speeds faster than 50 MPH (80 km/h).*
- *When driving on roads covered with snow or ice, the T-type spare tire should be used on the rear wheel and the original tire used on the front wheels (drive wheels). Use tire chains only on the front two original tires.*
- *Tire tread of the T-type spare tire will wear at a faster rate than the original tire. Replace the T-type spare tire as soon as the tread wear indicators appear.*
- *Do not use the T-type spare tire*

on other vehicles.

- *Do not use more than one T-type spare tire at the same time.*
- *Do not tow a trailer while the T-type spare tire is installed.*



CAUTION

- *Do not use tire chains on a T-type spare tire. Tire chains will not fit properly on the T-type spare tire and may cause damage to the vehicle.*
- *Because the T-type spare tire is smaller than the original tire, ground clearance is reduced. To avoid damage to the vehicle do not drive over obstacles. Also do not drive the vehicle through an*

DO-IT-YOURSELF

*automatic car wash since it may
get caught.*

9 MAINTENANCE

General maintenance	9-3	Schedule 1.....	9-6
Explanation of maintenance items	9-3	Schedule 2.....	9-6
Periodic maintenance schedules	9-6	Explanation of maintenance items	9-11

MAINTENANCE

Your new INFINITI has been designed to have minimum maintenance requirements with longer service intervals to save you both time and money. However, some day-to-day and regular maintenance is essential to maintain your INFINITI's good mechanical condition, as well as its emission and engine performance.

It is the owner's responsibility to make sure that the specified maintenance, as well as general maintenance, is performed.

As the vehicle owner, you are the only one who can ensure that your vehicle receives the proper maintenance care. You are a vital link in the maintenance chain.

General maintenance:

General maintenance includes those items which should be checked during normal day-to-day operation of the vehicle. They are essential if your vehicle is to continue to operate properly. It is your responsibility to

perform these procedures regularly as prescribed.

These checks or inspections can be done by yourself, a qualified technician or, if you prefer, your INFINITI retailer.

Periodic maintenance:

The maintenance items listed in this part are required to be serviced at regular intervals.

However, under severe driving conditions, additional or more frequent maintenance will be required.

Where to go for service:

If maintenance service is required or your vehicle appears to malfunction, have the systems checked and tuned by an authorized INFINITI retailer.

INFINITI technicians are well-trained specialists and are kept up to date with the latest service information through technical bulletins, service tips, and in-retailership training

programs. They are completely qualified to work on INFINITI's vehicles **before** they work on your vehicle, rather than after they have worked on it.

You can be confident that your INFINITI retailer's service department performs the best job to meet the maintenance requirements on your vehicle — in a reliable and economic way.

MAINTENANCE

GENERAL MAINTENANCE

During the normal day-to-day operation of the vehicle, general maintenance should be performed regularly as prescribed in this section. If you detect any unusual sounds, vibrations or smell, be sure to check for the cause or have your INFINITI retailer do it promptly. In addition, you should notify your INFINITI retailer if you think that repairs are required.

When performing any checks or maintenance work, see “Maintenance precautions” in the “8. Do-it-yourself” section.

EXPLANATION OF MAINTENANCE ITEMS

Additional information on the following items with “*” is found in the “8. Do-it-yourself” section.

Outside the vehicle

The maintenance items listed here should be performed from time to time, unless otherwise specified.

Tires*: Check the pressure with a gauge at least once a month and always prior to long distance trips. If necessary adjust the pressure in all tires, including the spare, to the pressure specified. Check carefully for damage, cuts or excessive wear.

Wheel nuts*: When checking the tires, make sure no nuts are missing, and check for any loose nuts. Tighten if necessary.

Tire rotation*: Tires should be rotated every 7,500 miles (12,000 km).

Wheel alignment and balance: If the vehicle pulls to either side while driving on a straight and level road, or if you detect uneven or abnormal tire wear, there may be a need for wheel alignment.

If the steering wheel or seat vibrates at normal highway speeds, wheel balancing may be needed.

For additional information regarding tires, refer to “Important Tire Safety Information” (US) or “Tire Safety Information” (Canada) in the INFINITI Warranty Information booklet.

Windshield: Clean the windshield on a regular basis. Check the windshield at least every six months for cracks or other damage. Have a damaged windshield repaired by a qualified repair facility.

Windshield wiper blades*: Check for cracks or wear if they do not wipe properly.

Doors and engine hood: Check that all doors and the engine hood, operate smoothly

MAINTENANCE

as well as the trunk lid or back hatch. Also make sure that all latches lock securely. Lubricate if necessary. Make sure that the secondary latch keeps the hood from opening when the primary latch is released.

When driving in areas using road salt or other corrosive materials, check lubrication frequently.

Inside the vehicle

The maintenance items listed here should be checked on a regular basis, such as when performing periodic maintenance, cleaning the vehicle, etc.

Lights*: Clean the headlights on a regular basis. Make sure that the headlights, stop lights, tail lights, turn signal lights, and other lights are all operating properly and installed securely. Also check headlight aim.

Warning lights and chimes: Make sure that all warning lights and chimes are operating properly.

Windshield wiper and washer*: Check that the wipers and washer operate properly and that the wipers do not streak.

Windshield defroster: Check that the air comes out of the defroster outlets properly and in good quantity when operating the heater or air conditioner.

Steering wheel: Check that it has the specified play. Be sure to check for changes in the steering conditions, such as excessive free play, hard steering or strange noises.

Seats: Check seat position controls such as seat adjusters, seatback recliner, etc. to ensure they operate smoothly and that all latches lock securely in every position. Check that the head restraints move up and down smoothly and that the locks (if so equipped) hold securely in all latched positions.

Seat belts: Check that all parts of the seat belt system (For example, buckles, anchors, adjusters and retractors) operate properly and

smoothly, and are installed securely. Check the belt webbing for cuts, fraying, wear or damage.

Accelerator pedal: Check the pedal for smooth operation and make sure the pedal does not catch or require uneven effort. Keep the floor mats away from the pedal.

Brakes: Check that the brakes do not pull the vehicle to one side when applied.

Brake pedal and booster*: Check the pedal for smooth operation and make sure it has the proper distance under it when depressed fully. Check the brake booster function. Be sure to keep floor mats away from the pedal.

Parking brake*: Check that the lever has the proper travel and make sure that the vehicle is held securely on a fairly steep hill when only the parking brake is applied.

Automatic transaxle P (Park) position mechanism: On a fairly steep hill check that the vehicle is held securely with the selector

MAINTENANCE

lever in the P (Park) position without applying any brakes.

Under the hood and vehicle

The maintenance items listed here should be checked periodically (For example, each time you check the engine oil or refuel).

Windshield washer fluid*: Check that there is adequate fluid in the tank.

Engine coolant level*: Check the coolant level when the engine is cold.

Radiator and hoses: Check the front of the radiator and clean off any dirt, insects, leaves, etc., that may have accumulated. Make sure the hoses have no cracks, deformation, deterioration or loose connections.

Brake fluid level*: Make sure that the brake fluid level is between the MAX and MIN lines on the reservoir.

Battery*: Check the fluid level in each cell. It should be between the MAX and MIN lines.

Vehicles operated in high temperatures or under severe conditions require frequent checks of the battery fluid level.

Engine drive belts*: Make sure that no belt is frayed, worn, cracked or oily.

Engine oil level*: Check the level on the dipstick after parking the vehicle on a level spot and turning off the engine.

Power steering fluid level* and lines: Check the level in the reservoir tank with the engine off. Check the lines for proper attachment, leaks, cracks, etc.

Automatic transaxle fluid level*: Check the level on the dipstick after putting the selector lever in the P (Park) position with the engine idling.

Exhaust system: Make sure there are no loose supports, cracks or holes. If the sound of the exhaust seems unusual or there is a smell of exhaust fumes, immediately locate the trouble and correct it. (See "Precautions when

starting and driving" in the "5. Starting and driving" section for exhaust gas (carbon monoxide).)

Underbody: The underbody is frequently exposed to corrosive substances such as those used on icy roads or to control dust. It is very important to remove these substances, otherwise rust will form on the floor pan, frame, fuel lines and around the exhaust system. At the end of winter, the underbody should be thoroughly flushed with plain water, being careful to clean those areas where mud and dirt may accumulate. For additional information, see "Cleaning exterior" in the "7. Appearance and care" section.

Fluid leaks: Check under the vehicle for fuel, oil, water or other fluid leaks after the vehicle has been parked for a while. Water dripping from the air conditioner after use is normal. If you should notice any leaks or if gasoline fumes are evident, check for the cause and have it corrected immediately.

MAINTENANCE

PERIODIC MAINTENANCE SCHEDULES

To ensure smooth, trouble-free, safe and economical driving, INFINITI provides two different maintenance schedules that may be used, depending upon the conditions in which you usually drive. These schedules contain both distance and time intervals, up to 60,000 miles (96,000 km)/48 months. For most people, the odometer reading will indicate when service is needed. However, if you drive very little, your vehicle should be serviced at the regular time intervals shown in the schedule. **After 60,000 miles (96,000 km) or 48 months, continue the periodic maintenance at the same mileage/time intervals.**

SCHEDULE 1

Follow Periodic Maintenance Schedule 1 if your driving habits frequently include one or more of the following driving conditions:

- repeated short trips of less than 5 miles (8 km).
- repeated short trips of less than 10 miles (16 km) with outside temperatures remaining below freezing.
- operating in hot weather in stop-and-go rush hour traffic.
- extensive idling and/or low speed driving for long distances, such as police, taxi or door-to-door delivery use.
- driving in dusty conditions.
- driving on rough, muddy, or salt spread roads.
- towing a trailer, using a camper or a car-top carrier.

SCHEDULE 2

Follow Periodic Maintenance Schedule 2 if none of the driving conditions shown in

Schedule 1 apply to your driving habits.

MAINTENANCE

Schedule 1

Abbreviations: R = Replace I = Inspect. Correct or replace if necessary.

[]: At the mileage intervals only

MAINTENANCE OPERATION	MAINTENANCE INTERVAL																
	Miles x 1,000	3.8	7.5	11.3	15	18.8	22.5	26.3	30	33.8	37.5	41.3	45	48.8	52.5	56.3	60
Perform at number of miles, kilometers or months, whichever comes first.	(km x 1,000)	(6)	(12)	(18)	(24)	(30)	(36)	(42)	(48)	(54)	(60)	(66)	(72)	(78)	(84)	(90)	(96)
	Months	3	6	9	12	15	18	21	24	27	30	33	36	39	42	45	48
Emission control system maintenance																	
Drive belts	See NOTE (1)																I*
Air cleaner filter	See NOTE (2)								[R]								[R]
EVAP vapor lines																	I*
Fuel lines																	I*
Fuel filter	See NOTE (3)																
Engine coolant	See NOTE (4)																R*
Engine oil		R	R	R	R	R	R	R	R	R	R	R	R	R	R	R	R
Engine oil filter (Use part No. 15208-31U00 or 15208-65F00 or equivalent)		R	R	R	R	R	R	R	R	R	R	R	R	R	R	R	R
Spark plugs (Use PLATINUM-TIPPED type)		Replace every 105,000 miles (169,000 km)															
Intake & exhaust valve clearance*	See NOTE (5)																

- NOTE: (1) After 60,000 miles (96,000 km) or 48 months, inspect every 15,000 miles (24,000 km) or 12 months.
 (2) If operating mainly in dusty conditions, more frequent maintenance may be required.
 (3) Maintenance-free item.
 (4) After 60,000 miles (96,000 km) or 48 months, replace every 30,000 miles (48,000 km) or 24 months.
 (5) If valve noise increases, inspect valve clearance.

* Maintenance items and intervals with "*" are recommended by INFINITI for reliable vehicle operation. The owner need not perform such maintenance in order to maintain the emission warranty or manufacturer recall liability. Other maintenance items and intervals are required.

MAINTENANCE

Schedule 1

Abbreviations: R = Replace I = Inspect. Correct or replace if necessary.

MAINTENANCE OPERATION		MAINTENANCE INTERVAL																	
		Miles x 1,000	3.8	7.5	11.3	15	18.8	22.5	26.3	30	33.8	37.5	41.3	45	48.8	52.5	56.3	60	
Perform at number of miles, kilometers or months, whichever comes first.	(km x 1,000)	(6)	(12)	(18)	(24)	(30)	(36)	(42)	(48)	(54)	(60)	(66)	(72)	(78)	(84)	(90)	(96)		
	Months	3	6	9	12	15	18	21	24	27	30	33	36	39	42	45	48		
Chassis and body maintenance																			
Brake lines & cables						I				I				I					I
Brake pads & rotors				I		I		I		I		I		I		I		I	
Automatic transaxle fluid		See NOTE (1)				I		I		I		I		I		I		I	
Steering gear & linkage, axle & suspension parts				I		I		I		I		I		I		I		I	
Tire rotation		See NOTE (2)																	
Exhaust system				I		I		I		I		I		I		I		I	
Front drive shaft boots				I		I		I		I		I		I		I		I	
In-cabin microfilter						R				R				R					R

NOTE: (1) If towing a trailer, using a camper or a car-top carrier, or driving on rough or muddy roads, change (not just inspect) oil at every 30,000 miles (48,000 km) or 24 months.

(2) Refer to "Tire rotation" under the "General maintenance" heading earlier in this section.

MAINTENANCE

Schedule 2

Abbreviations: R = Replace I = Inspect. Correct or replace if necessary.

[]: At the mileage intervals only

MAINTENANCE OPERATION		MAINTENANCE INTERVAL							
	Miles x 1,000	7.5	15	22.5	30	37.5	45	52.5	60
Perform at number of miles, kilometers or months, whichever comes first.	(km x 1,000)	(12)	(24)	(36)	(48)	(60)	(72)	(84)	(96)
	Months	6	12	18	24	30	36	42	48
Emission control system maintenance									
Drive belts	See NOTE (1)								I*
Air cleaner filter					[R]				[R]
EVAP vapor lines					I*				I*
Fuel lines					I*				I*
Fuel filter	See NOTE (2)								
Engine coolant	See NOTE (3)								R*
Engine oil		R	R	R	R	R	R	R	R
Engine oil filter (Use part No. 15208-31U00 or 15208-65F00 or equivalent)		R	R	R	R	R	R	R	R
Spark plugs (Use PLATINUM-TIPPED type)		Replace every 105,000 miles (169,000 km)							
Intake & exhaust valve clearance*	See NOTE (4)								

NOTE: (1) After 60,000 miles (96,000 km) or 48 months, inspect every 15,000 miles (24,000 km) or 12 months.

(2) Maintenance-free item.

(3) After 60,000 miles (96,000 km) or 48 months, replace every 30,000 miles (48,000 km) or 24 months.

(4) If valve noise increases, inspect valve clearance.

* Maintenance items and intervals with "*" are recommended by INFINITI for reliable vehicle operation. The owner need not perform such maintenance in order to maintain the emission warranty or manufacturer recall liability. Other maintenance items and intervals are required.

MAINTENANCE

Schedule 2

Abbreviations: R = Replace I = Inspect. Correct or replace if necessary.

MAINTENANCE OPERATION		MAINTENANCE INTERVAL								
Perform at number of miles, kilometers or months, whichever comes first.	Miles x 1,000	7.5	15	22.5	30	37.5	45	52.5	60	
	(km x 1,000)	(12)	(24)	(36)	(48)	(60)	(72)	(84)	(96)	
	Months	6	12	18	24	30	36	42	48	
Chassis and body maintenance										
Brake lines & cables			I		I		I		I	
Brake pads & rotors			I		I		I		I	
Automatic transaxle fluid			I		I		I		I	
Steering gear & linkage, axle & suspension parts					I				I	
Tire rotation		See NOTE (1)								
Exhaust system					I				I	
Front drive shaft boots			I		I		I		I	
In-cabin microfilter			R		R		R		R	

NOTE: (1) Refer to "Tire rotation" under the "General maintenance" heading earlier in this section.

MAINTENANCE

EXPLANATION OF MAINTENANCE ITEMS

Additional information on the following items with "*" is found in the "8. Do-it-yourself" section.

Emission control system maintenance

Drive belts*: Check drive belts for wear, fraying or cracking and also for proper tension. Replace the drive belts if found damaged.

Air cleaner filter: Under normal driving conditions, the air cleaner filter should be replaced in accordance with the maintenance schedule. However, driving the vehicle in dusty areas may cause more rapid clogging of the element. Consequently, the element may have to be replaced more frequently.

EVAP vapor lines: Check vapor lines and connections for failure or looseness. If leaks are found, replace them.

Fuel lines: Check the fuel hoses, piping and connections for leaks, looseness or deterioration. Replace any parts if they are damaged.

Engine coolant*: Drain and flush the cooling system.

Engine oil & oil filter*: Under normal driving conditions, the engine oil and oil filter should be replaced in accordance with the maintenance schedule. However, under severe driving conditions, they may have to be replaced more frequently.

Spark plugs*: Replace with new plugs having the correct heat range.

Intake & exhaust valve clearance: check and adjust the valve clearance.

Chassis and body maintenance

Brake lines & cables: Check the brake lines and hoses (including brake booster vacuum hoses, connections & check valve) and parking brake cables for proper attachment, leaks,

cracks, chafing, abrasion, deterioration, etc.

Brake pads & rotors: Check these and the other neighboring brake components for wear, deterioration and leaks. Under severe driving conditions, they may have to be inspected more frequently.

Automatic transaxle fluid*: Check the oil level and visually inspect for signs of leakage.

Under severe driving conditions, the oil should be replaced at the specified interval.

Steering gear & linkage, axle & suspension parts, and front drive shaft boots: Check for damage, looseness and leakage of oil or grease. Under severe driving conditions, more frequent inspection should be performed.

Exhaust system: Visually check the exhaust pipes, muffler, and hangers for proper attachment, leaks, cracks, chafing, abrasion, deterioration, etc. Under severe driving conditions, inspection should be performed more frequently.

MAINTENANCE

In-cabin microfilter: Under normal conditions, the in-cabin microfilter should be replaced in accordance with the maintenance schedule. However, in some situations, the microfilter may clog more rapidly (depending on the air conditioner's working environment). If this happens, the air flow may decrease, or the windows may fog up easily when the air conditioner is in use, the microfilter should be replaced immediately at your INFINITI dealer.

10 TECHNICAL AND CONSUMER INFORMATION

Capacities and recommended fuel/lubricants	10-2	Vehicle identification number (Chassis number)	10-11
Fuel recommendation.....	10-3	Engine serial number	10-11
Engine oil and oil filter recommendation	10-5	F.M.V.S.S. certification label	10-11
Recommended SAE viscosity number	10-7	Emission control information label	10-12
Air conditioning system refrigerant and lubricant recommendations.....	10-7	Tire placard	10-12
Specifications	10-8	Air conditioner specification label.....	10-12
Engine.....	10-8	Installing front license plate.....	10-13
Wheels and tires	10-9	Vehicle loading information.....	10-14
Dimensions and weights.....	10-9	Terms	10-14
When traveling or registering your vehicle in another country.....	10-10	Determining vehicle payload capacity	10-15
Vehicle identification.....	10-10	Loading tips.....	10-15
Vehicle identification number (VIN) plate.....	10-10	Towing a trailer.....	10-16
		Maximum load limits.....	10-16
		Towing safety	10-17
		Uniform tire quality grading	10-20
		Emission control system warranty	10-21
		Reporting safety defects (US only)	10-21

Readiness for inspection/maintenance (I/M)
test (US only) 10-22
Owner's Manual/Service Manual order
information 10-23

In the event of a collision 10-23

TECHNICAL AND CONSUMER INFORMATION

CAPACITIES AND RECOMMENDED FUEL/LUBRICANTS

The following are approximate capacities. The actual refill capacities may be a little different. When refilling, follow the procedure instructed in the "8. Do-it-yourself" section to determine the proper refill capacity.

	Capacity (Approximate)			Recommended specifications
	US measure	Imp measure	Liter	
Fuel	18-1/2 gal	15-3/8 gal	70	Unleaded gasoline with an octane rating of at least 91 AKI (RON 96)*1
Engine oil*6 Drain and refill				
With oil filter change	4-1/4 qt	3-1/2 qt	4.0	<ul style="list-style-type: none"> • API Certification Mark *2, *3 • API grade SG/SH, Energy Conserving I & II or API grade SJ or SL, Energy Conserving *2, *3 • ILSAC grade GF-I, GF-II & GF-III*2, *3
Without oil filter change	3-7/8 qt	3-1/4 qt	3.7	
Cooling system				
With reservoir	8-1/8 qt	6-3/4 qt	7.7	Genuine NISSAN anti-freeze coolant or equivalent
Reservoir	7/8 qt	3/4 qt	0.8	
Automatic transmission fluid				Nissan Matic "D" (Continental US and Alaska) or Canada Nissan Automatic Transmission Fluid.*4
Power steering fluid	Refill to the proper oil level according to the instructions in the "8. Do-it-yourself" section.			Genuine Nissan PSFII or equivalent*8
Brake and clutch fluid				Genuine Nissan Brake Fluid*5 or equivalent DOT 3 (US FMVSS No. 116)
Multi-purpose grease	—	—	—	NLGI No. 2 (Lithium soap base)
Air conditioning system refrigerant	—	—	—	HFC-134a (R-134a)*7
Air conditioning system lubricants	—	—	—	INFINITI A/C System Oil Type S or exact equivalent

*1: For additional information, see later in this paragraph for fuel recommendation.

*2: For additional information, see later in this paragraph for engine oil and oil filter recommendation.

*3: For additional information, see later in this paragraph for recommended SAE viscosity number.

*4: Dexron™ III/Mercon™ or equivalent may also be used. Outside the continental United States and Alaska contact an INFINITI retailer for more information regarding suitable fluids, including recommended brand(s) of Dexron™ III/Mercon™ automatic transmission fluid.

*5: Available in mainland US through your INFINITI retailer.

*6: For additional information, see "Engine oil" in the "8. Do-it-yourself" section for changing engine oil.

*7: For additional information, see "Vehicle identification" in the "10. Technical and consumer information" for air conditioner specification label.

*8: Genuine Nissan PSF, Canada Nissan Automatic Transmission fluid, Dexron™ III/Mercon™ or equivalent ATF may also be used.

TECHNICAL AND CONSUMER INFORMATION

FUEL RECOMMENDATION

Use unleaded premium gasoline with an octane rating of at least 87 AKI (Anti-Knock Index) number (Research octane number 91)

For improved vehicle performance, INFINITI recommends the use of unleaded premium gasoline with an octane rating of at least 91 AKI (Research octane number 96).



CAUTION

Using a fuel other than that specified could adversely affect the emission control devices and systems, and could also affect the warranty coverage.

Under no circumstances should a leaded gasoline be used, since this will damage the three way catalyst.

Reformulated gasoline

Some fuel suppliers are now producing reformulated gasolines. These gasolines are specially designed to reduce vehicle emissions. INFINITI supports efforts towards cleaner air and suggests that you use reformulated gasoline when available.

Gasoline containing oxygenates

Some fuel suppliers sell gasoline containing oxygenates such as ethanol, MTBE and methanol with or without advertising their presence. INFINITI does not recommend the use of fuels of which oxygenate content and the fuel compatibility for your INFINITI cannot be readily determined. If in doubt, ask your service station manager.

If you use oxygenate-blend gasoline, please take the following precautions as the usage of such fuels may cause vehicle performance problems and/or fuel system damage.

- The fuel should be unleaded and have an octane rating no lower than that recommended for unleaded gasoline.
- If an oxygenate-blend, excepting a methanol blend, is used, it should contain no more than 10% oxygenate. (MTBE may, however, be added up to 15%.)
- If a methanol blend is used, it should contain no more than 5% methanol (methyl alcohol, wood alcohol). It should also contain a suitable amount of appropriate cosolvents and corrosion inhibitors. If not properly formulated with appropriate cosolvents and corrosion inhibitors, such methanol blends may cause fuel

TECHNICAL AND CONSUMER INFORMATION

system damage and/or vehicle performance problems. At this time, sufficient data is not available to ensure that all methanol blends are suitable for use in INFINITI vehicles.

If any undesirable driveability problems such as engine stalling and hard hot starting are experienced after using oxygenate-blend fuels, immediately change to a non-oxygenate fuel or a fuel with a low blend of MTBE.

Take care not to spill gasoline during refueling. Gasoline containing oxygenates can cause paint damage.

Aftermarket fuel additives

INFINITI does not recommend the use of any fuel additives (i.e. fuel injector cleaner, octane booster, intake valve deposit removers, etc.) which are sold commercially. Many of these additives intended for gum, varnish or deposit removal may contain active solvent or similar

ingredients that can be harmful to the fuel system and engine.

Octane rating tips

In most parts of North America, you should use unleaded gasoline with an octane rating of at least 87 or 91 AKI (Anti-Knock Index) number. However, you may use unleaded gasoline with an octane rating as low as 85 AKI number in these high altitude areas [over 4,000 ft (1,219 m)] such as: Colorado, Montana, New Mexico, Utah, Wyoming, northeastern Nevada, southern Idaho, western South Dakota, western Nebraska, and that part of Texas which is directly south of New Mexico.

Using unleaded gasoline with an octane rating lower than stated above can cause persistent, heavy spark knock. (Spark knock is a metallic rapping noise.) If severe, this can lead to engine damage. If you detect a persistent heavy spark knock even when using gasoline

of the stated octane rating, or if you hear steady spark knock while holding a steady speed on level roads, have your retailer correct the condition. Failure to correct the condition is misuse of the vehicle, for which INFINITI is not responsible.

Incorrect ignition timing will result in knocking, after-run or overheating. This in turn may cause excessive fuel consumption or damage to the engine. If any of the above symptoms are encountered, have your vehicle checked at an INFINITI retailer or other competent service facility.

However, now and then you may notice light spark knock for a short time while accelerating or driving up hills. This is no cause for concern, because you get the greatest fuel benefit when there is light spark knock for a short time under heavy engine load.

TECHNICAL AND CONSUMER INFORMATION

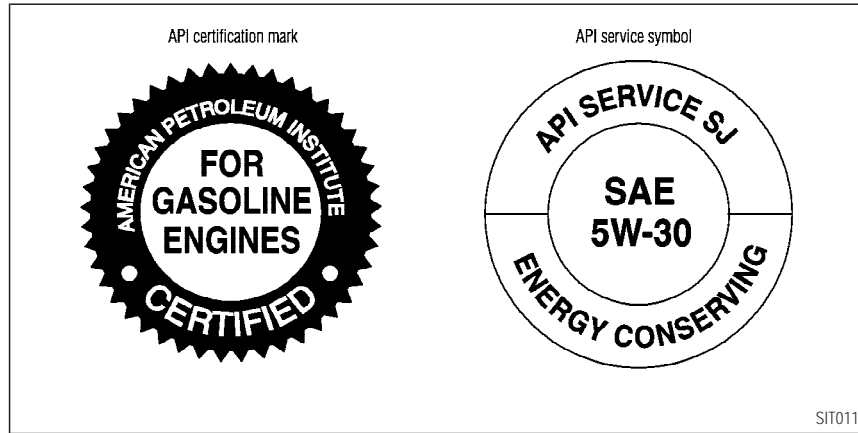

ENGINE OIL AND OIL FILTER RECOMMENDATION

Selecting the correct oil

It is essential to choose the correct quality, and viscosity oil to ensure satisfactory engine life and performance. INFINITI recommends the use of a low friction oil (energy conserving

oil) in order to improve fuel economy and conserve energy. Oils which do not have the specified quality label should not be used as they could cause engine damage.

Only those engine oils with the American Petroleum Institute (API) certification mark on the front of the container should be used. This

type of oil supersedes the existing API SG or SH and Energy Conserving II categories.

If you cannot find engine oil with the API certification mark, use an API grade SG/SH, Energy Conserving I & II or API grade SJ or SL, Energy Conserving oil. An oil with a single designation SG or SH, or in combination with other categories (For example, SG/CC or SG/CD) may also be used if one with the API certification mark cannot be found. An ILSAC grade GF-I, II & III oil can also be used.

INFINITI recommends mineral based oils. These oils must however, meet the API quality and SAE viscosity ratings specified for your vehicle.

Oil additives

INFINITI does not recommend the use of oil additives. The use of an oil additive is not necessary when the proper oil type is used and maintenance intervals are followed.

TECHNICAL AND CONSUMER INFORMATION

Oil which may contain foreign matter or has been previously used should not be used.

Oil viscosity

The engine oil viscosity or thickness changes with temperature. Because of this, it is important that the engine oil viscosity be selected based on the temperatures at which the vehicle will be operated before the next oil change. The recommended SAE viscosity number chart shows the recommended oil viscosities for the expected ambient temperatures. Choosing an oil viscosity other than that recommended could cause serious engine damage.

Selecting the correct oil filter

Your new vehicle is equipped with a high-quality genuine INFINITI oil filter. When replacing, use the genuine oil filter or its equivalent for the reason described in change intervals.

Change intervals

The oil and oil filter change intervals for your engine are based on the use of the specified quality oils and filters. Oil and filter other than the specified quality, or oil and filter change intervals longer than recommended could reduce engine life. Damage to engines caused by improper maintenance or use of incorrect oil and filter quality and/or viscosity is not covered by the new INFINITI vehicle warranties.

Your engine was filled with a high quality engine oil when it was built. You do not have to change the oil before the first recommended change interval. Oil and filter change intervals depend upon how you use your vehicle. Operation under the following conditions may require more frequent oil and filter changes.

- repeated short distance driving at cold outside temperatures,
- driving in dusty conditions,
- extensive idling,
- towing a trailer.

TECHNICAL AND CONSUMER INFORMATION

RECOMMENDED SAE VISCOSITY NUMBER

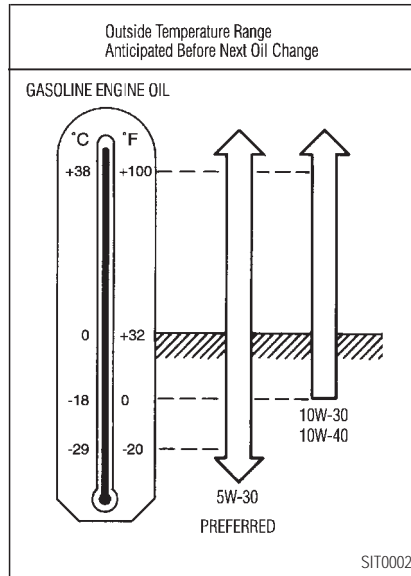

SAE 5W-30 viscosity oil is preferred for all ambient temperatures. SAE 10W-30, 10W-40 viscosity oil may be used if the ambient temperature is above 0°F (-18°C).

AIR CONDITIONING SYSTEM REFRIGERANT AND LUBRICANT RECOMMENDATIONS

The air conditioning system in this INFINITI vehicle must be charged with the refrigerant HFC-134a (R-134a) and the lubricant, INFINITI A/C System Oil Type S or the exact equivalents.



The use of any other refrigerant or lubricant will cause severe damage to the air conditioning system and will require the replacement of all air conditioner system components.

The refrigerant HFC-134a (R-134a) in your INFINITI vehicle will not harm the earth's ozone layer. Although this refrigerant does not affect the earth's atmosphere, certain governmental regulations require the recovery and recycling of any refrigerant during automotive air conditioning system service. Your INFINITI retailer has the trained technicians and equipment needed to recover and recycle your air conditioning system refrigerant.

Contact your INFINITI retailer whenever servicing your air conditioning system.

TECHNICAL AND CONSUMER INFORMATION

SPECIFICATIONS

ENGINE

Model		VQ35DE
Type		Gasoline, 4-cycle
Cylinder arrangement		6-cylinder, V-slanted at 60°
Bore x Stroke	in (mm)	3.760 x 3.205 (955 x 81.4)
Displacement	cu in (cm ³)	213.45 (3,498)
Firing order		1-2-3-4-5-6*
Idle speed	rpm	
Ignition timing (B.T.D.C.)	degree/rpm	See the emission control label on the underside of the hood.
CO percentage at idle speed	[No air] %	
Spark plug	Standard	PLFR5A-11
	Service option	PLFR4A-11, PLFR6A-11
Spark plug gap	in (mm)	0.043 (1.1)
Camshaft operation		Timing chain

The spark ignition system of this vehicle meets all requirements of the Canadian Interference-Causing Equipment Regulations.

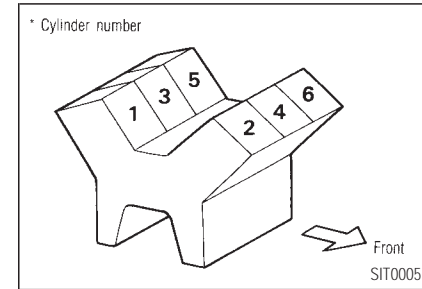

TECHNICAL AND CONSUMER INFORMATION

WHEELS AND TIRES

Road wheel	Aluminum	Size	Offset in (mm)
		17 x 7JJ 17 x 7JJ*	1.57 (40) 1.75 (45)
Tire size	Conventional	P215/55HR17 P225/50VR17*	
	Spare	Conventional T135/90D16 (T type)	

*: t-pack

DIMENSIONS AND WEIGHTS

		Sedan
Overall length	in (mm)	193.7 (4,921)
Overall width	in (mm)	70.2 (1,782)
Overall height	in (mm)	57.0 (1,449)*1 56.7 (1,440)*2
Front tread	in (mm)	60.2 (1,530)*1 59.8 (1,520)*2
Rear tread	in (mm)	59.4 (1,510)*1 59.1 (1,500)*2
Wheelbase	in (mm)	108.3 (2,750)
Gross vehicle weight rating	lb (kg)	
Gross axle weight rating		See the F.M.V.S.S. certification label on the driver's side lock pillar.
Front	lb (kg)	
Rear	lb (kg)	

*1: For models with tire size - P215/55HR17

*2: For models with tire size - P225/50VR17

TECHNICAL AND CONSUMER INFORMATION

WHEN TRAVELING OR REGISTERING YOUR VEHICLE IN ANOTHER COUNTRY

When planning to travel in another country, you should first find out if the fuel available is suitable for your vehicle's engine.

Using fuel with too low an octane rating may cause engine damage. All gasoline vehicles must be operated with unleaded engine gasoline. Therefore, avoid taking your vehicle to areas where appropriate fuel is not available.

When transferring the registration of your vehicle to another country, state, province or district, it may be necessary to modify the vehicle to meet local laws and regulations.

The laws and regulations for motor vehicle emission control and safety standards vary according to the country, state, province or district; therefore, vehicle specifications may differ.

10-10

When any vehicle is to be taken into another country, state, province or district and registered, its modifications, transportation, and registration are the responsibility of the user. INFINITI is not responsible for any inconvenience that may result.

VEHICLE IDENTIFICATION

VEHICLE IDENTIFICATION NUMBER (VIN) PLATE

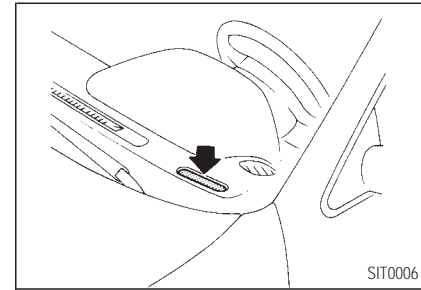

The vehicle identification number plate is attached as shown. This number is the identification for your vehicle and is used in the vehicle registration.

TECHNICAL AND CONSUMER INFORMATION

VEHICLE IDENTIFICATION NUMBER (Chassis number)

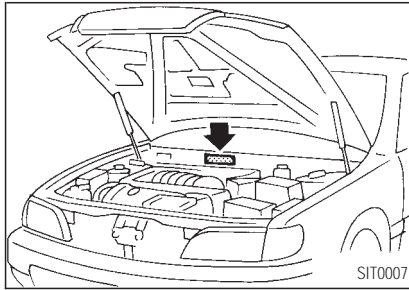

The number is stamped as shown.

ENGINE SERIAL NUMBER

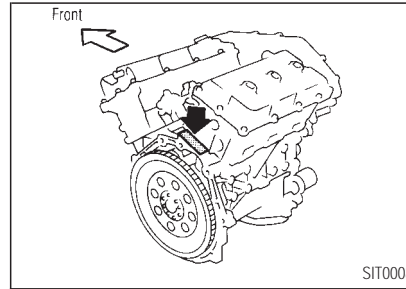

The number is stamped on the engine as shown.

F.M.V.S.S. CERTIFICATION LABEL

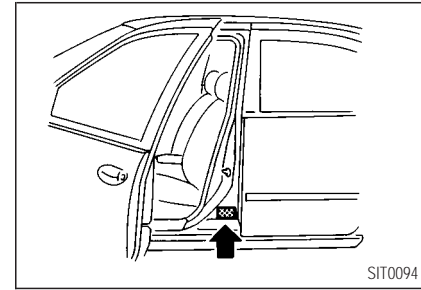

The Federal Motor Vehicle Safety Standards (F.M.V.S.S.) certification label is affixed as shown. This label contains valuable vehicle information, such as: Gross Vehicle Weight Ratings (GVWR), Gross Axle Weight Rating (GAWR), month and year of manufacture, Vehicle Identification Number, (VIN), etc. Review it carefully.

TECHNICAL AND CONSUMER INFORMATION

EMISSION CONTROL INFORMATION LABEL

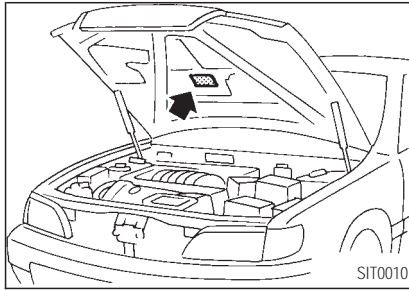

The emission control information label is attached as shown.

TIRE PLACARD

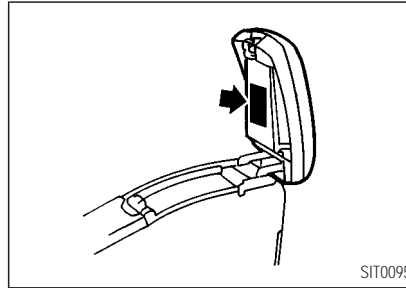

The cold tire pressure is shown on the tire placard affixed to the console box lid.

AIR CONDITIONER SPECIFICATION LABEL

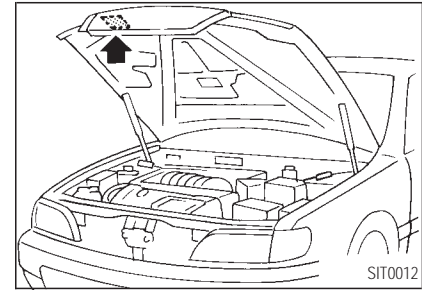

The label is affixed inside of the hood as shown.

TECHNICAL AND CONSUMER INFORMATION

INSTALLING FRONT LICENSE PLATE

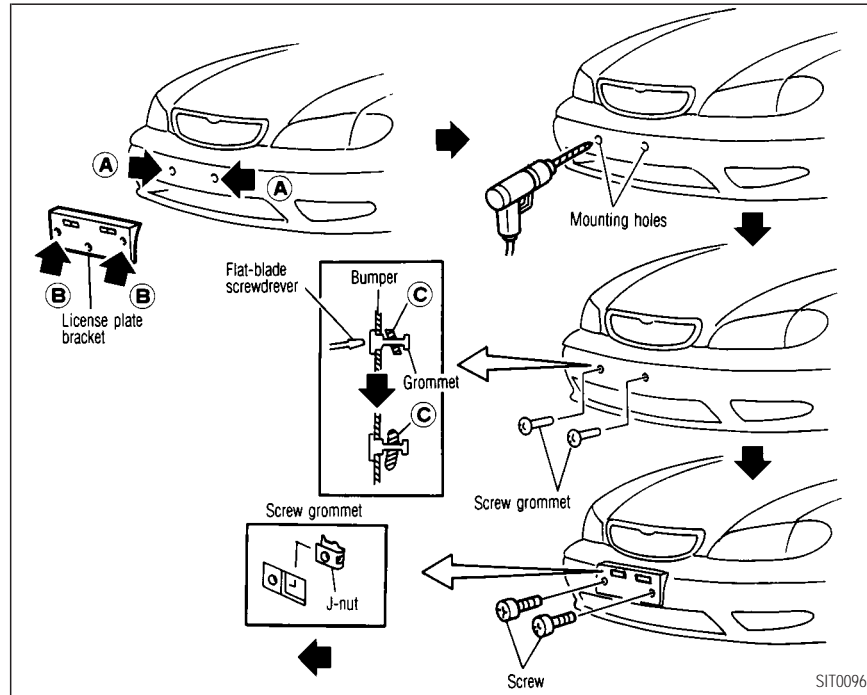

TECHNICAL AND CONSUMER INFORMATION

Use the following steps to mount the license plate:

Before mounting the license plate, confirm that the following parts are enclosed in the vinyl bag.

- License plate bracket
- J-nut x 2
- Screw x 2
- Screw grommet x 2

1. Temporarily place the license plate bracket while aligning points **(A)** of the front bumper fascia with holes **(B)** in the license plate bracket.
2. Remove the license plate bracket.
3. Carefully drill two pilot holes **(A)** using a 0.39 in (10 mm) drill bit at the marked locations. **(Be sure that the drill only goes through the fascia, or damage to the nut may occur.)**

4. Insert grommets into the hole on the fascia.
5. Insert a flat-blade screwdriver into the grommet hole to add 90° turn onto the part **(C)**.
6. Insert a J-nut into the license plate bracket before placing the license plate bracket on the fascia.
7. Install the license plate bracket with screws.
8. Install the license plate with bolts that are no longer than 0.55 in (14 mm).

VEHICLE LOADING INFORMATION



WARNING

- ***It is extremely dangerous to ride in a cargo area inside of a vehicle. In***

a collision, people riding in these areas are more likely to be seriously injured or killed.

- ***Do not allow people to ride in any area of your vehicle that is not equipped with seats and seat belts.***
- ***Be sure everyone in your vehicle is in a seat and using a seat belt properly.***

TERMS

It is important to familiarize yourself with the following terms before loading your vehicle:

- **Curb Weight** (actual weight of your vehicle) - vehicle weight including: standard and optional equipment, fluids, emergency tools, and spare tire assembly. This weight **does not** include passengers and cargo.
- **GVW** (Gross Vehicle Weight) - curb weight

TECHNICAL AND CONSUMER INFORMATION

plus the combined weight of passengers and cargo.

- GVWR (Gross Vehicle Weight Rating) - maximum total weight (load) limit specified for the vehicle.
- GAWR (Gross Axle Weight Rating) - maximum weight (load) limit specified for the front or rear axle.

DETERMINING VEHICLE PAY-LOAD CAPACITY

The load capacity of this vehicle is determined by weight, not by available cargo space. For example, a luggage rack, bike carrier, cartop carrier or similar equipment does not increase load carrying capacity of your vehicle.

To determine vehicle load capacity:

Vehicle weight can be determined by using a commercial-grade scale, found at places such as a truck stop, gravel quarry, grain elevator, or a scrap metal recycling facility.

1. Determine the curb weight of your vehicle.
2. Compare the curb weight amount to the GVWR specified for your vehicle to determine how much more weight your vehicle can carry.
3. After loading (cargo and passengers), re-weigh your vehicle to determine if either GVWR or GAWR for your vehicle is exceeded. If GVWR is exceeded, remove cargo as necessary. If either the front or rear GAWR is exceeded, shift the load or remove cargo as necessary.

LOADING TIPS

- The GVW must not exceed GVWR or GAWR as specified on the F.M.V.S.S. certification label.
- Do not load the front and rear axle to the GAWR. Doing so will exceed the GVWR.



WARNING

- *Properly secure all cargo to help prevent it from sliding or shifting. Do not place cargo higher than the seatbacks. In a sudden stop or collision, unsecured cargo could cause personal injury.*
- *Do not load your vehicle any heavier than the GVWR or the maximum front and rear GAWRs. If you do, parts on your vehicle can break, or it can change the way your vehicle handles. This could result in loss of control and cause personal injury.*
- *Overloading can shorten the life of your vehicle. Failures caused by overloading are not covered by your warranty.*

TECHNICAL AND CONSUMER INFORMATION

TOWING A TRAILER

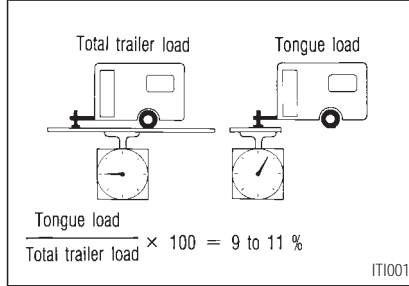

Your new vehicle was designed to be used primarily to carry passengers and cargo. Remember that towing a trailer will place additional loads on your vehicle's engine, drive train, steering, braking and other systems.

Information on trailer towing ability and the special equipment required should be obtained from your INFINITI retailer. He can obtain an **INFINITI Trailer Towing Guide** for you.

MAXIMUM LOAD LIMITS

Maximum trailer loads

Never allow the total trailer load to exceed 1,000 lb (454 kg). The total trailer load equals trailer weight plus its cargo weight. Towing loads greater than 1,000 lb (454 kg) or using improper towing equipment could adversely affect vehicle handling, braking and performance.

The ability of your vehicle to tow a trailer is not only related to the maximum trailer loads, but also the places you plan to tow. Tow weights appropriate for level highway driving may have to be reduced on very steep grades or in low traction situations (for example, on slippery boat ramps).



WARNING

Vehicle damage and/or personal injury resulting from improper towing

procedures are not covered by INFINITI warranties. A Nissan Trailer Towing Guide (U.S. only) containing information on trailer towing ability and the special equipment required may be obtained from an authorized INFINITI retailer.

Tongue load

Keep the tongue load between 9 and 11% of the total trailer load. If the tongue load becomes excessive, rearrange cargo to allow for proper tongue load.

TECHNICAL AND CONSUMER INFORMATION

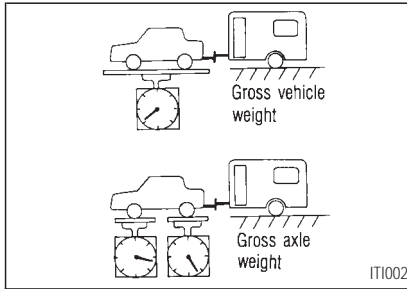

Maximum gross vehicle weight/maximum gross axle weight

The gross vehicle weight of the towing vehicle must not exceed the GVWR shown on the F.M.V.S.S. certification label. The gross vehicle weight equals the combined weight of the unloaded vehicle, passengers, luggage, hitch, trailer tongue load and any other optional equipment. In addition, front or rear gross axle weight must not exceed the GAWR shown on the F.M.V.S.S. certification label.

TOWING LOAD/SPECIFICATION CHART UNIT: lb (kg)	
MAXIMUM TOWING LOAD	1,000 (454)
MAXIMUM TONGUE LOAD	110 (49)

TOWING SAFETY

Trailer hitch

Choose a proper hitch for your vehicle and trailer. Make sure the trailer hitch is securely attached to the vehicle, to help avoid personal injury or property damage due to sway caused by crosswinds, rough road surfaces or passing trucks.



- *Do not use axle-mounted hitches.*
- *The hitch should not be attached to or affect the operation of the impact-absorbing bumper*
- *Do not modify the vehicle exhaust system, brake system, etc. to install a trailer hitch.*
- *To reduce the possibility of additional damage if your vehicle is struck from the rear, where practical, remove the hitch and/or receiver when not in use. After the hitch is removed, seal the bolt holes to prevent exhaust fumes, water or dust from entering the passenger compartment.*

TECHNICAL AND CONSUMER INFORMATION

- **Regularly check that all hitch mounting bolts are securely mounted.**

Tire pressures

- When towing a trailer, inflate the vehicle tires to the recommended cold tire pressure indicated on the tire placard (located on the inside of the center console lid.)
- Trailer tire condition, size, load rating and proper inflation pressure should be in accordance with the trailer and tire manufacturers' specifications.

Safety chains

Always use a suitable chain between your vehicle and the trailer. The chain should be crossed and should be attached to the hitch, not to the vehicle bumper or axle. Be sure to leave enough slack in the chain to permit turning corners.

10-18

Trailer lights

Trailer lights should comply with federal and/or local regulations. When wiring the vehicle for towing, connect the stop and tail light pickup into the vehicle electrical circuit at a point between the sensor and stop light or light switch.

Trailer brakes

If your trailer is equipped with a braking system, make sure it conforms to federal and/or local regulations and that it is properly installed.



WARNING

Never connect a trailer brake system directly to the vehicle brake system.

Pre-towing tips

- Be certain your vehicle maintains a level position when a loaded and/or unloaded

trailer is hitched. Do not drive the vehicle if it has an abnormal nose-up or nose-down condition; check for improper tongue load, overload, worn suspension or other possible causes of either condition.

- Always secure items in the trailer to prevent load shifts while driving.
- Be certain your rear view mirrors conform to all federal, state or local regulations. If not, install any mirrors required for towing before driving the vehicle.

Trailer towing tips

In order to gain skill and an understanding of the vehicle's behavior, you should practice turning, stopping and backing up in an area which is free from traffic. Steering stability, and braking performance will be somewhat different than under normal driving conditions.

- Always secure items in the trailer to prevent load shift while driving.

TECHNICAL AND CONSUMER INFORMATION

- Avoid abrupt starts, acceleration or stops.
- Avoid sharp turns or lane changes.
- Always drive your vehicle at a moderate speed.
- Always block the wheels on both vehicle and trailer when parking. Parking on a slope is not recommended; however, if you must do so, and if your vehicle is equipped with automatic transmission, first block the wheels and apply the parking brake, and then move the transmission selector lever into the P (Park) position. If you move the selector lever to the P (Park) position before blocking the wheels and applying the parking brake, transmission damage could occur.
- When going down a hill, shift into a lower gear and use the engine braking effect. When ascending a long grade, downshift the transmission to a lower gear and reduce speed to reduce chances of engine overloading and/or overheating.
- If the engine coolant rises to an extremely high temperature when the air conditioning system is on, turn off the air conditioner. Coolant heat can be additionally vented by opening the windows, switching the fan control to high and setting the temperature control to the HOT position.
- Trailer towing requires more fuel than normal circumstances.
- Avoid towing a trailer for the first 500 miles (800 km).
- Have your vehicle serviced more often than at intervals specified in the recommended maintenance schedule.
- When making a turn, your trailer wheels will be closer to the inside of the turn than your vehicle wheels. To compensate for this, make a larger than normal turning radius during the turn.
- Crosswinds and rough roads will adversely affect vehicle/trailer handling, possibly causing vehicle sway. When being passed by larger vehicles, be prepared for possible changes in crosswinds that could affect vehicle handling. If swaying does occur, firmly grip the steering wheel, steer straight ahead, and immediately (but gradually) reduce vehicle speed. This combination will help stabilize the vehicle. Never increase speed.
- Be careful when passing other vehicles. Passing while towing a trailer requires considerably more distance than normal passing. Remember the length of the trailer must also pass the other vehicle before you can safely change lanes.
- To maintain engine braking efficiency and electrical charging performance, do not use fifth gear (manual transmission) or overdrive (automatic transmission).
- Avoid holding the brake pedal down too long or too frequently. This could cause

TECHNICAL AND CONSUMER INFORMATION

the brakes to overheat, resulting in reduced braking efficiency.

When towing a trailer, change oil in the transmission more frequently.

See “Periodic maintenance schedules” in the “9. Maintenance” section.

UNIFORM TIRE QUALITY GRADING

DOT (Department Of Transportation) Quality Grades: All passenger car tires must conform to federal safety requirements in addition to these grades.

Quality grades can be found where applicable on the tire sidewall between tread shoulder and maximum section width. For example:

Treadwear 200 Traction AA Temperature A

Treadwear

Treadwear grade is a comparative rating based on tire wear rate when tested under controlled conditions on specified government test courses. For example, a tire graded 150 would wear one and a half (1-1/2) times as well on the government course as a tire graded 100. However, relative tire performance depends on actual driving conditions, and may vary significantly from the norm due to variations in driving habits, service practices and differences in road characteristics and climate.

Traction AA, A, B and C

The traction grades, from highest to lowest, are AA, A, B, and C. Those grades represent the tire's ability to stop on wet pavement as measured under controlled conditions on specified government test surfaces of asphalt and concrete. A tire marked C may have poor traction performance.



WARNING

The traction grade assigned to your vehicle tires is based on straight-ahead braking traction tests, and does not include acceleration, cornering, hydroplaning, or peak traction characteristics.

Temperature A, B and C

Temperature grades are A (the highest), B, and C. They represent a tire's resistance to heat build-up, and its ability to dissipate heat when tested under controlled conditions on a specified indoor laboratory test wheel. Sustained high temperature can cause tire material to degenerate, reducing tire life. Excessive temperatures can lead to sudden tire failure. Grade C corresponds to a performance level which all passenger car tires must meet under the Federal Motor Vehicle Safety Standard No.

TECHNICAL AND CONSUMER INFORMATION

109. Grades A and B represent higher levels of performance on laboratory test wheels than the minimum required by law.



WARNING

The temperature grade for this tire is established for a tire that is properly inflated and not overloaded. Excessive speed, underinflation, or excessive loading, either separately or in combination, can cause heat buildup and possible tire failure.

EMISSION CONTROL SYSTEM WARRANTY

Your INFINITI is covered by the following emission warranties.

For US:

- Emission Defects Warranty

- Emissions Performance Warranty (See Warranty Information Booklet for details.)

For Canada:

Emission Control System Warranty

Details of these warranties may be found with other vehicle warranties in your Warranty Information Booklet (Warranty and Roadside Assistance Information (Canada only)) that comes with your INFINITI. If you did not receive a Warranty Information Booklet (Warranty and Roadside Assistance Information (Canada only)), or it has become lost, you may obtain a replacement by writing to:

- INFINITI Division
Nissan North America, Inc.
Consumer Affairs Department
P.O. Box 47038, Gardena, CA 90247-6838
- Nissan Canada Inc.
5290 Orbitor Drive

Mississauga, Ontario, L4W 4Z5

- INFINITI Division
Nissan Motor Corporation in Hawaii, Ltd.
Consumer Affairs Department
2880 Kilihau Street
Honolulu, Hawaii 96819

REPORTING SAFETY DEFECTS (US only)

If you believe that your vehicle has a defect which could cause a crash or could cause injury or death, you should immediately inform the National Highway Traffic Safety Administration (NHTSA) in addition to notifying INFINITI.

If NHTSA receives similar complaints, it may open an investigation, and if it finds that a safety defect exists in a group of vehicles, it may order a recall and remedy campaign. However, NHTSA cannot become involved in individual problems between you, your retailer, or INFINITI.

TECHNICAL AND CONSUMER INFORMATION

To contact NHTSA, you may call the Auto Safety Hotline toll-free at 1-888-327-4236. If you reside in Hawaii, please call 808-836-0888. You may also write to: NHTSA, U.S. Department of Transportation, Washington, D.C. 20590. You can also obtain other information about motor vehicle safety from the Hotline.

You may notify INFINITI by contacting our Consumer Affairs Department, toll-free, at 1-800-662-6200. In Hawaii call 808-836-0848.

READINESS FOR INSPECTION/ MAINTENANCE (I/M) TEST (US only)

Due to legal requirements in some states, your vehicle may be required to be in what is called the ready condition for an Inspection/Maintenance (I/M) test of the emission control system.

The vehicle is set to the ready condition when it is driven through certain driving patterns. Usually, the ready condition can be obtained by ordinary usage of the vehicle.

If a powertrain system component is repaired or the battery is disconnected, the vehicle may be reset to a not ready condition. Before taking the I/M test, drive the vehicle through the following pattern to set the vehicle to the ready condition. If you cannot or do not want to perform the driving pattern, an INFINITI retailer can conduct it for you.



WARNING

Always drive the vehicle in a safe and prudent manner according to traffic conditions, and obey all traffic laws.

1. Start the engine. Allow the engine to idle until the engine coolant temperature gauge

needle points between the C and H (normal operating temperature).

2. Accelerate the vehicle to 55 MPH (88 km/h), then quickly release the accelerator pedal completely and keep it released for at least 6 seconds.
3. Quickly depress the accelerator pedal for a moment, then drive the vehicle at a speed of 53 to 60 MPH (86 to 96 km/h) for at least 5 minutes.
4. Stop the vehicle. Leave the engine running.
5. Accelerate the vehicle to 35 MPH (55 km/h) and maintain the speed for 20 seconds.
6. Repeat steps 4 and 5 at least three times.
7. Accelerate the vehicle to 55 MPH (88 km/h) and maintain the speed for at least 3 minutes.
8. Stop the vehicle. Place the transmission

TECHNICAL AND CONSUMER INFORMATION

gear (selector lever in the “P” or “N” position).

9. Turn the engine off.
10. Repeat steps 1 through 8 at least one more time.

If step 1 through 7 is interrupted, repeat the preceding step. Any safe driving mode is acceptable between steps. Do not stop the engine until step 7 is completed.

OWNER'S MANUAL/SERVICE MANUAL ORDER INFORMATION

A genuine INFINITI Service Manual is the best source of service and repair information for your vehicle. Filled with wiring diagrams, illustrations and step-by-step diagnostic and adjustment procedures, this manual is the same one used by the factory trained technicians working at authorized INFINITI dealerships. Also available are genuine INFINITI

Owner's Manuals, and genuine INFINITI Service and Owner's Manuals for older INFINITI models.

In the USA:

For current pricing and availability of genuine **INFINITI Service Manuals** for the 2000 model year and later, contact:

Tweddle Litho Company
1-800-639-8841
www.nissan-techinfo.com

For current pricing and availability of genuine **INFINITI Service Manuals** for the 1999 model year and prior, see an authorized INFINITI dealer, or contact:

DDS Distribution Services, Ltd.
20770 Westwood Road
Strongsville, OH 44136
1-800-247-5321

For current pricing and availability of genuine **INFINITI Owner's Manuals** for the 2002

model year and prior, see an authorized INFINITI dealer, or contact:

DDS Distribution Services, Ltd.
20770 Westwood Road
Strongsville, OH 44136
1-800-247-5321

In Canada:

To purchase a copy of a genuine INFINITI Service Manual or Owner's Manual please contact your nearest INFINITI dealer. For the phone number and location of an INFINITI dealer in your area call the INFINITI Satisfaction Center at 1-800-361-4792 and a bilingual INFINITI representative will assist you.

Also available are genuine INFINITI Service and Owner's Manuals for older INFINITI models.

IN THE EVENT OF A COLLISION

Unfortunately, accidents do occur. In this unlikely event, there is some important infor-

TECHNICAL AND CONSUMER INFORMATION

mation you should know. Many insurance companies routinely authorize the use of non-genuine collision parts in order to cut costs, among other reasons.

Insist on the use of Genuine Infiniti Collision Parts!

If you want your vehicle to be restored using parts made to INFINITI's original exacting specifications — if you want to help it to last and hold its resale value, the solution is simple. **Tell your insurance agent and your repair shop to only use Genuine Infiniti Collision Parts.** INFINITI does not warrant non-Infiniti parts, nor does Infiniti's warranty apply to damage caused by a non-genuine parts.

Using Genuine Infiniti Parts can help protect your personal safety, preserve your warranty protection and maintain the resale value of your vehicle. And if your vehicle was leased, using Genuine Infiniti Parts may prevent or

limit unnecessary excess wear and tear expenses at the end of your lease.

INFINITI designs its hoods with crumple zones to minimize the risk that the hood will penetrate the windshield of your vehicle in an accident. Non-genuine (imitation) parts may not provide such built in safeguards. Also, non-genuine parts often show premature wear, rust and corrosion.

Why should you take a chance?

In over 40 states, the law says you must be advised if non-genuine parts are used to repair your vehicle. And some states/provinces have enacted laws that restrict insurance companies from authorizing the use of non-genuine collision parts during the new vehicle warranty. These laws help protect you, so you can take action to protect yourself.

It's your right!

11 Index

A

ABS (Anti-lock brake system)	5-17
Air bag system	
Front (See supplemental front air bag system)...	1-14
Side (See supplemental side air bag system).....	1-16
Air bag warning labels	1-20
Air bag warning light.....	1-20, 2-10
Air cleaner housing filter.....	8-16
Air conditioner	
Air conditioner operation.....	4-3
Air conditioner service.....	4-3, 4-6
Air conditioner specification label.....	10-12
Air conditioning system refrigerant and lubricant recommendations.....	4-6, 10-7
Heater and air conditioner (automatic).....	4-3
Microfilter	4-6
Alcohol, drugs and driving.....	5-4
Anchor point locations	
Top tether strap.....	1-41
Antenna	4-28
Anti-lock Brake System (ABS).....	5-17
Anti-lock brake warning light.....	2-8
Appearance care	
Exterior appearance care.....	7-2

Interior appearance care.....	7-4
Armrest.....	1-7
Ashtray (See cigarette lighter and ashtray)	2-25
Audible reminders.....	2-13
Audio operation precautions.....	4-8
Audio system	4-7
Steering wheel audio controls.....	4-27
Autochanger	
Compact Disc (CD).....	4-17
Automatic	
Anti-glare inside mirror	3-16
Automatic transmission fluid (ATF).....	8-10
Drive positioner.....	3-19
Driving with automatic transmission	5-8
Seat positioner, seat.....	3-19
Transmission selector lever lock release	5-10
Avoiding collision and rollover	5-4

B

Battery	8-13
Battery saver system	2-19
Before starting the engine	5-7
Belts (See drive belts).....	8-14

Brake

Anti-lock brake system (ABS).....	5-17
Brake booster.....	8-19
Brake fluid.....	8-12
Brake pedal	8-18
Brake pedal check.....	8-18
Brake system.....	5-16
Parking brake check.....	5-11, 8-18
Parking brake operation.....	5-11
Warning light	2-8
Break-in schedule	5-14
Bulb check/instrument panel	2-7

C

Cabin air filter.....	4-6
Capacities and recommended fuel/lubricants.....	10-2
Car phone or CB radio.....	4-30
Cargo (See vehicle loading information)	2-28
Cargo net.....	2-28
Cassette player (See audio system)	4-16, 4-24
Catalytic converter, Three way catalyst.....	5-3
CD care and cleaning.....	4-27
Child restraints	1-32
Installation on front passenger seat	1-42

INDEX

Installation on rear seat center or outboard positions.....	1-34
Precautions on child restraints.....	1-32
Top tether strap anchor point locations.....	1-41
With top tether strap.....	1-41
Child safety.....	1-26
Child safety rear door lock.....	3-4
Chimes, Audible reminders.....	2-13
Cigarette lighter and ashtray.....	2-25
Circuit breaker, Fusible link.....	8-20
Cleaning exterior and interior.....	7-2, 7-4
Clock.....	2-34
Cold weather driving.....	5-21
Compact Disc (CD) autochanger.....	4-29
Compact Disc (CD) changer operation.....	4-17
Compact spare tire.....	8-36
Console box.....	2-28
Controls	
Heater and air conditioner controls (automatic)....	4-3
Steering wheel audio controls.....	4-27
Coolant	
Capacities and recommended fuel/ lubricants	10-2
Changing engine coolant.....	8-6
Checking engine coolant level.....	8-5
Cornering light.....	2-21

Corrosion protection.....	7-6
Cruise control.....	5-12
Cup holder.....	2-26

D

Daytime running light system.....	2-20
Defogger switch, Rear window and outside mirror defogger switch.....	2-17
Dimensions and weights.....	10-9
Door open warning light.....	2-9
Drive bells.....	8-14
Drive positioner, Automatic.....	3-19
Driving	
Cold weather driving.....	5-21
Driving with automatic transmission.....	5-5, 5-8
Precautions when starting and driving.....	5-2

E

Economy, Fuel.....	5-14
Electric sunroof.....	2-31
Emission control information label.....	10-12
Emission control system warranty.....	10-21

Engine

Before starting the engine.....	5-7
Capacities and recommended fuel/lubricants.....	10-2
Changing engine coolant.....	8-6
Changing engine oil.....	8-8
Changing engine oil filter.....	8-9
Checking engine coolant level.....	8-5
Checking engine oil level.....	8-7
Coolant temperature gauge.....	2-5
Engine block heater.....	5-23
Engine compartment check locations.....	8-4
Engine cooling system.....	8-5
Engine oil.....	8-7
Engine oil and oil filter recommendation.....	10-5
Engine oil viscosity.....	10-6
Engine serial number.....	10-11
Engine specifications.....	10-8
If your vehicle overheats.....	6-10
Starting the engine.....	5-7
Exhaust gas (Carbon monoxide).....	5-2

F

F.M.V.S.S. certification label.....	10-11
Filter, Air cleaner housing filter.....	8-16

INDEX

Flashers (See hazard warning flasher switch).....	2-21
Flat tire.....	6-2
Floor mat cleaning.....	7-5
Fluid	
Automatic transmission fluid (ATF).....	8-10
Brake fluid.....	8-12
Capacities and recommended fuel/lubricants.....	10-2
Engine coolant.....	8-5
Engine oil.....	8-7
Power steering fluid.....	8-12
Window washer fluid.....	8-13
FM-AM-SAT radio with cassette player.....	4-20
FM-AM-SAT radio with cassette player and compact disc (CD) player/CD changer.....	4-12
Fog light switch.....	2-21
Folding rear seat.....	1-4
Front air bag system (See supplemental restraint system).....	1-14
Front fog light switch.....	2-21
Front power seat adjustment.....	1-3
Fuel	
Capacities and recommended fuel/lubricants.....	10-2
filler cap.....	3-13
filler lid.....	3-13
Fuel economy.....	5-14

Fuel octane rating.....	10-3
Fuel recommendation.....	10-3
Gauge.....	2-5
Fuses.....	8-19
Fusible links.....	8-20

G

Garage door opener, HomeLink® Universal Transceiver.....	2-39
Gas cap.....	3-13
Gauge.....	2-3
Engine coolant temperature gauge.....	2-5
Fuel gauge.....	2-5
Odometer.....	2-4
Speedometer.....	2-4
Tachometer.....	2-4
Trip computer.....	2-35
General maintenance.....	9-2, 9-3
Glove box.....	2-27
Glove box lock.....	2-27

H

Hazard warning flasher switch.....	2-21
------------------------------------	------

Head restraints.....	1-5
Headlights	
Bulb replacement.....	8-24
Headlight switch.....	2-18
Xenon headlights.....	2-17
Heated seats.....	2-22
Heated steering wheel.....	2-23
Heater	
Engine coolant heater.....	5-23
Heater and air conditioner (automatic).....	4-3
HomeLink® Universal Transceiver.....	2-39
Hood, release.....	3-10
Horn.....	2-22
How to stop alarm, Vehicle security.....	2-15

I

Ignition switch.....	5-5
Automatic transmission models.....	5-5
Key positions.....	5-6
Immobilizer system.....	2-15
In-cabin microfilter.....	4-6
Indicator lights.....	2-11
Infiniti Vehicle Immobilizer System, Engine start.....	5-6
Inside Automatic anti-glare mirror.....	3-16

INDEX

Inspection/maintenance (I/M) test	10-22
Instrument panel	2-2
Interior light	2-36
Interior light replacement.....	8-26
Interior trunk lid release	3-12
ISOFIX child restrain	1-39

J

Jump starting	6-7
---------------------	-----

K

Keyless entry (See remote keyless entry system)	3-5
Keys	3-2

L

Label, Air conditioner specification label	10-12
Label, Emission control information label	10-12
Label, F.M.V.S.S. certification label	10-11
Labels	
Air bag warning labels.....	1-20
Engine serial number	10-11
Vehicle identification number (VIN)	10-10

LATCH system.....	1-39
License plate, Installing front license plate.....	10-13
Light	
Air bag warning light.....	1-20
Cornering light.....	2-21
Front fog light switch	2-21
Headlight switch.....	2-18
Headlights Bulb replacement.....	8-24
Interior light	2-36
Personal light.....	2-37
Trunk light	2-39
Vanity mirror lights.....	2-39
Warning/indicator lights and audible reminders	2-8, 2-11
Xenon headlights	2-17
Lights, Exterior and interior light replacement.....	8-26
Loading information (See vehicle loading information).....	10-14
Lock	
Door locks.....	3-3
Glove box lock.....	2-27
Power door lock	3-3
Trunk lid lock opener lever	3-11
Low fuel warning light.....	2-9

M

Maintenance

Battery	8-13
Chassis and body.....	9-11
Emission control system.....	9-11
General maintenance.....	9-2, 9-3
Inside the vehicle.....	9-4
Maintenance precautions	8-2
Outside the vehicle	9-3
Periodic maintenance schedules.....	9-6
Seat belt maintenance.....	1-32
Under the hood and vehicle.....	9-5
Meters and gauges	2-3

Mirror

Automatic anti-glare inside mirror.....	3-16
Outside mirror control	3-18
Outside mirrors	3-18

N

Net, Cargo net	2-28
New vehicle break-in	5-14
Nissan vehicle Immobilizer System.....	2-13

INDEX

O

Odometer.....	2-4
Oil	
Capacities and recommended fuel/lubricants.....	10-2
Changing engine oil.....	8-8
Changing engine oil filter.....	8-9
Checking engine oil level.....	8-7
Engine oil.....	8-7
Engine oil viscosity.....	10-6
Outside mirror control.....	3-18
Outside mirrors.....	3-18
Overheat, If your vehicle overheats.....	6-10
Owner's Manual/Service Manual order information.....	10-23

P

Parking	
Brake check.....	8-18
Parking brake check.....	5-11
Parking brake operation.....	5-11
Parking on hills.....	5-11
Parking/parking on hills.....	5-15
Periodic maintenance schedules.....	9-6

Personal light.....	2-37
Phone, Car phone or CB radio.....	4-30
Power	
Front seat adjustment.....	1-3
Power door lock.....	3-3
Power outlet.....	2-24
Power steering fluid.....	8-12
Power steering system.....	5-16
Power windows.....	2-29
Pre-tensioner seat belt system.....	1-18
Precautions	
Audio operation precautions.....	4-8
Braking precautions.....	5-16
Cruise control precautions.....	5-12
Maintenance precautions.....	8-2
On child restraints.....	1-32
On seat belt usage.....	1-22
Precautions on supplemental restraint system.....	1-7
Precautions when starting and driving.....	5-2
Push starting.....	6-10

R

Radio.....	4-7
Car phone or CB radio.....	4-30

Steering wheel audio controls.....	4-27
Readiness for inspection/maintenance (I/M) test (US only).....	10-22
Rear door lock, Child safety rear door lock.....	3-4
Rear power point.....	2-24
Rear seat trunk release.....	3-12
Rear sun shade.....	2-33
Rear window and outside mirror defogger switch.....	2-17
Registering your vehicle in another country.....	10-10
Remote keyless entry system.....	3-5
Reporting safety defects (US only).....	10-21
Roadside assistance program.....	6-2
Rollover.....	5-4

S

Safety	
Child seat belts.....	1-26
Reporting safety defects (US only).....	10-21
Towing safety.....	10-17
Satellite radio operation.....	4-23
Seat belt warning light and chime.....	2-10
Seat adjustment, Front power seat adjustment.....	1-3
Seat belt(s)	
Child safety.....	1-26

INDEX

Infants and small children.....	1-27	Speedometer	2-4
Injured persons.....	1-28	Starting	
Larger children.....	1-27	Before starting the engine.....	5-7
Pre-tensioner seat belt system	1-18	Jump starting	6-7
Precautions on seat belt usage	1-22	Precautions when starting and driving.....	5-2
Pregnant women	1-27	Push starting.....	6-10
Seat belt cleaning	7-5	Starting the engine.....	5-7
Seat belt extenders.....	1-31	Steering	
Seat belt maintenance.....	1-32	Heated steering wheel.....	2-23
Seat belts	1-22	Power steering fluid.....	8-12
Three-point type with retractor	1-28	Power steering system.....	5-16
Seat(s)		Steering wheel switch for audio controls.....	4-27
Heated seats.....	2-22	Tilting steering wheel.....	3-15
Seats.....	1-2	Sun shade.....	2-32
Security systems (Infiniti Vehicle Immobilizer System),		Rear sun shade.....	2-33
Engine start.....	2-15	Sun visors.....	3-16
Security systems (See vehicle security system)	2-13	Sunglasses holder	2-26
Servicing air conditioner.....	4-3, 4-6	Sunroof	2-31
Shift lock release	5-10	Electric sunroof.....	2-31
Shifting		Supplemental air bag warning labels.....	1-20
Automatic transmission.....	5-5, 5-8	Supplemental air bag warning light	1-20, 2-10
Shoulder belt height adjustment, For front seats	1-31	Supplemental front air bag system	1-14
Side air bag system (See supplemental side air bag		Supplemental restraint system.....	1-7
system).....	1-16	Precautions on supplemental restraint system.....	1-7
Spark plugs.....	8-15	Supplemental side air bag system	1-16

Switch	
Audio control	4-27
Front fog light switch	2-21
Hazard warning flasher switch.....	2-21
Headlight switch.....	2-18
Ignition switch.....	5-5
Ignition switch automatic transmission	
models.....	5-5, 5-8
Power door lock switch	3-4
Rear window and outside mirror defogger	
switch	2-17
Traction control system cancel switch.....	2-24
Turn signal switch	2-20
Vehicle dynamic control off switch	2-24

T

Tachometer	2-4
Temperature gauge, Engine coolant temperature	
gauge	2-5
Theft (Infiniti Vehicle Immobilizer System), Engine	
start	2-15
Three way catalyst	5-3
Tilting steering wheel	3-15
Tire	
Flat tire.....	6-2

INDEX

Uniform tire quality grading	10-20
Tires	
Spare tire.....	8-36
Tire chains	8-34
Tire placard.....	10-12
Tire pressure.....	8-32
Tire rotation.....	8-34
Types of tires.....	8-33
wheel/tire size	10-9
Wheels and tires	8-32
Top tether strap child restraints.....	1-41
Towing	
Tow truck towing.....	6-12
Towing a trailer.....	10-16
Towing load/specification chart.....	10-16
Towing safety.....	10-17
Traction control system.....	5-19
Traction control system (TCS) cancel switch.....	2-24
Trailer towing.....	10-16
Transceiver, HomeLink® Universal Transceiver	2-39
Transmission	
Automatic transmission fluid (ATF).....	8-10
Driving with automatic transmission	5-5, 5-8
Transmission selector lever lock release	5-10
Transmitter (See remote keyless entry system).....	3-5

Traveling or registering your vehicle in another country	10-10
Trip computer	2-35
Trunk	
Access through rear seat.....	1-4
Interior trunk lid release	3-12
Lid lock opener lever.....	3-11
Light	2-39
Rear seat trunk release	3-12
Turn signal switch.....	2-20

U

Underbody cleaning.....	7-3
Uniform tire quality grading	10-20

V

Vanity mirror lights.....	2-39
Vehicle	
Dimensions and weights.....	10-9
Dynamic control (VDC) system.....	5-20
Dynamic control off switch.....	2-24
Identification number (VIN).....	10-10
Loading information.....	10-14

Recovery (freeing a stuck vehicle).....	6-14
Vehicle security system	2-3
Ventilators.....	4-2

W

Warning labels, Air bag warning labels.....	1-20
Warning light	
Air bag warning light.....	1-20, 2-10
Anti-lock brake warning light	2-8
Brake warning light.....	2-8
Door open warning light.....	2-9
Low fuel warning light.....	2-9
Seat belt warning light and chime	2-10
Warning lights	2-8
Warning, Hazard warning flasher switch.....	2-21
Warning, Warning/indicator lights and audible reminders	2-7
Warranty, Emission control system warranty.....	10-21
Washer switch, Windshield wiper and washer switch.....	2-16
Washing.....	7-2
Waxing.....	7-3
Weights (See dimensions and weights).....	10-9
Wheel/tire size	10-9

INDEX

Wheels and tires.....	8-32
Cleaning aluminum alloy wheels.....	7-4
Window washer fluid.....	8-13
Window(s)	
Cleaning.....	7-3
Power windows.....	2-29
Windshield wiper and washer switch.....	2-16
Wiper	
Windshield wiper and washer switch.....	2-16
Wiper blades.....	8-16

X

Xenon headlights.....	2-17
-----------------------	------