

FOREWORD

Your INFINITI represents a new way of thinking about car design. It integrates advanced engineering and superior craftsmanship with a simple, refined aesthetic sensitivity associated with traditional Japanese culture.

The result is a different notion of luxury and beauty. The car itself is important, but so also is the sense of harmony that the car evokes in its driver, and the sense of satisfaction you feel with the INFINITI —from the way it looks and drives to the high level of dealer service.

To ensure that you enjoy your INFINITI to the fullest, we encourage you to read this Owner's Manual immediately. It explains all of the features, controls and performance characteristics of your INFINITI; it also provides important instructions and safety information.

A separate Warranty Information Booklet is to be found in your Owner's literature portfolio. Always carry it with you when you take your INFINITI to an authorized dealer. The portfolio contents provide complete information about all warranties covering this vehicle, the periodic maintenance required to keep the warranties in effect as well as the INFINITI Roadside Assistance program.

INFINITI is dedicated to providing a satisfying ownership experience for as long as you own your car. Should you have any questions regarding your INFINITI or your INFINITI dealer, please contact our Consumer Affairs department at 1-800-662-6200. In Hawaii 531-0231 (Oahu number). In Canada 1-800-363-4520. Thank you.

WHEN READING THE MANUAL

This manual includes information for all options available on this model. Therefore, you may find some information that does not apply to your vehicle.

All information, specifications and illustrations in this manual are those in effect at the time of printing. INFINITI reserves the right to change specifications or design at any time without notice.

MODIFICATION OF YOUR VEHICLE

This vehicle should not be modified. Modification could affect its

performance, safety or durability, and may even violate governmental regulations. In addition, damage or performance problems resulting from modification may not be covered under INFINITI warranties.

READ FIRST — THEN DRIVE SAFELY

Before driving your vehicle please read your Owner's Manual carefully. This will ensure familiarity with controls and maintenance requirements, assisting you in the safe operation of your vehicle.



WARNING

IMPORTANT SAFETY INFORMATION

REMINDERS FOR SAFETY!

Follow these five important driving rules to help ensure a safe and comfortable trip for you and your passengers!

- NEVER drive under the influence of alcohol or drugs.
- ALWAYS observe posted speed limits and never drive too fast for conditions.
- ALWAYS use your seat belts and appropriate child restraint systems.
- ALWAYS provide information about the proper use of vehicle safety features to all occupants of the vehicle.
- ALWAYS review this Owner's Manual for important safety information.

IMPORTANT INFORMATION ABOUT THIS MANUAL

You will see the various symbols in this manual. They are used in the following ways:



WARNING

This is used to indicate the presence of a hazard that could cause death or serious personal injury. To avoid or reduce the risk, the procedures must be followed precisely.



CAUTION

This is used to indicate the presence of a hazard that could cause minor or moderate personal injury or damage to your vehicle. To avoid or reduce the risk, the procedures must be followed carefully.

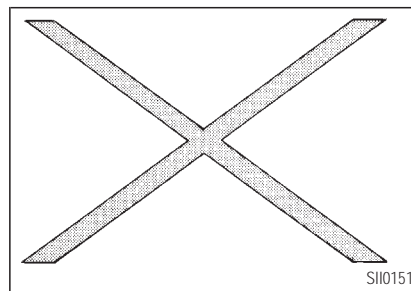

If you see this symbol, it means "Do not do this" or "Do not let this happen".



INFINITI®

© 1996 NISSAN MOTOR CO., LTD.
TOKYO, JAPAN

All rights reserved. No part of this Owner's Manual may be reproduced or stored in a retrieval system, or transmitted in any form, or by any means, electronic, mechanical, photocopying, recording or otherwise, without the prior written permission of Nissan Motor Co., Ltd.

TABLE OF CONTENTS

INSTRUMENTS AND CONTROLS	1-1
PRE-DRIVING CHECKS AND ADJUSTMENTS.....	2-1
HEATER/AIR CONDITIONER/AUDIO	3-1
STARTING AND DRIVING.....	4-1
IN CASE OF EMERGENCY	5-1
APPEARANCE AND CARE.....	6-1
DO-IT-YOURSELF	7-1
MAINTENANCE	8-1
TECHNICAL AND CONSUMER INFORMATION.....	9-1
INDEX	10-1

1 INSTRUMENTS AND CONTROLS

Meters and gauges	1-3	Book holder	1-19
Warning/indicator light and chime	1-6	Cargo net	1-19
Windshield wiper and washer switch	1-12	Power window	1-20
Rear window and outside door mirror defogger switch	1-13	Power window automatic switch	1-21
Headlight and turn signal switch	1-13	Sunroof	1-21
Instrument brightness control	1-15	Clock	1-22
Hazard warning flasher switch	1-15	Interior light	1-22
Heated seat	1-16	Vanity mirror light	1-23
Cigarette lighters and ashtrays	1-17	Personal light	1-23
Cup holder	1-18	Console light	1-23

INSTRUMENTS AND CONTROLS

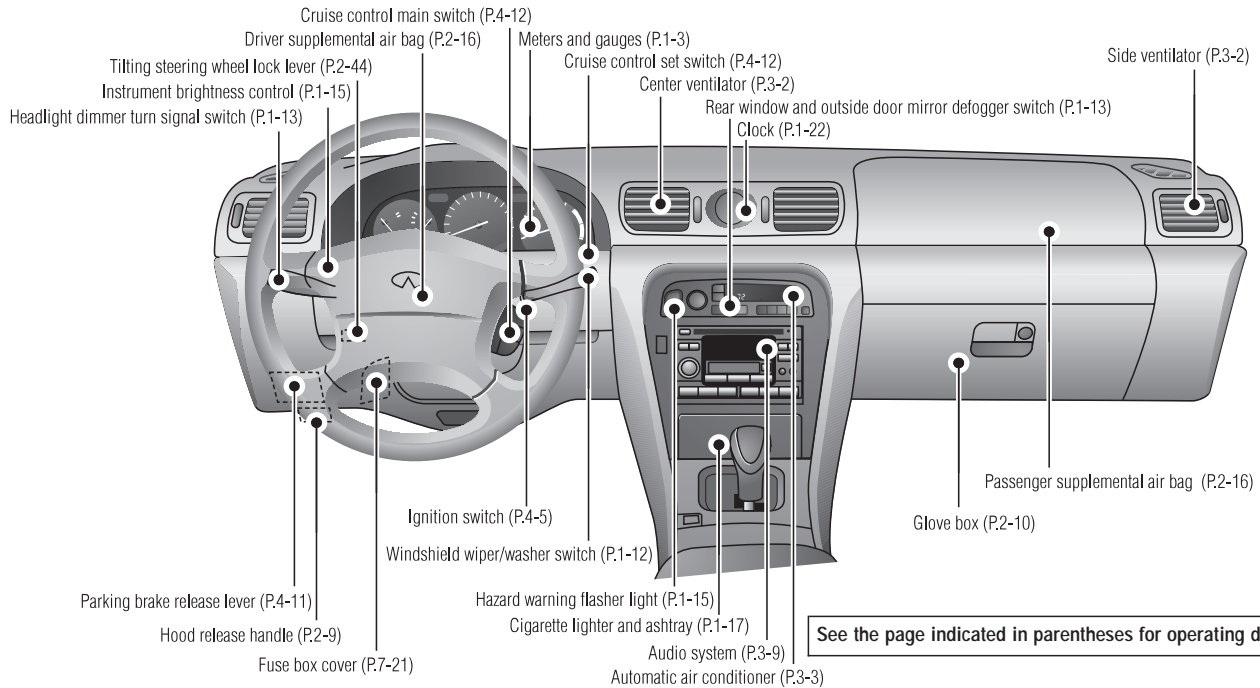

SI10122

INSTRUMENTS AND CONTROLS

METERS AND GAUGES

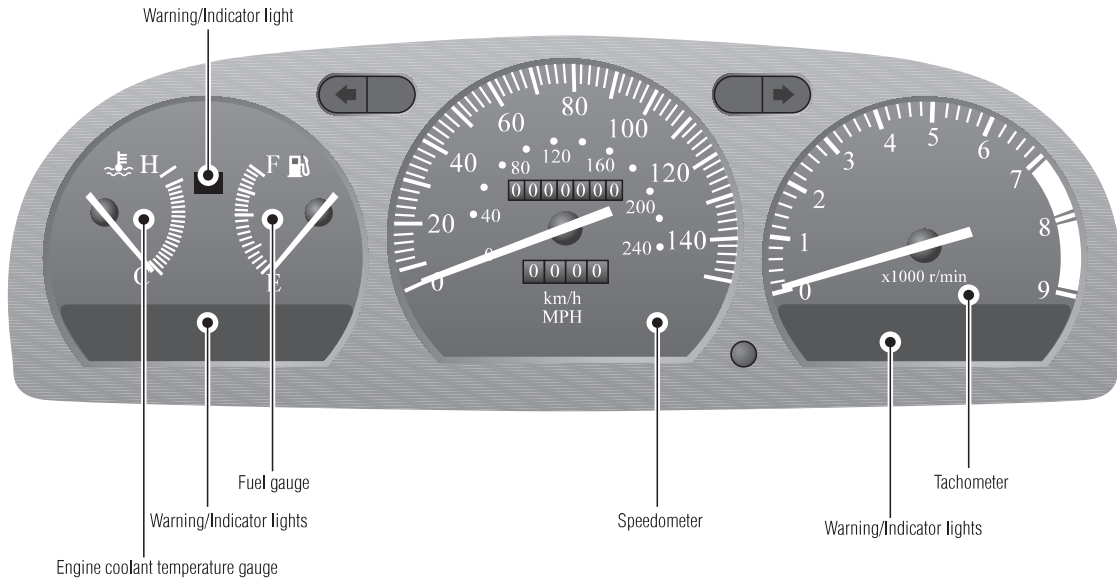

INSTRUMENTS AND CONTROLS

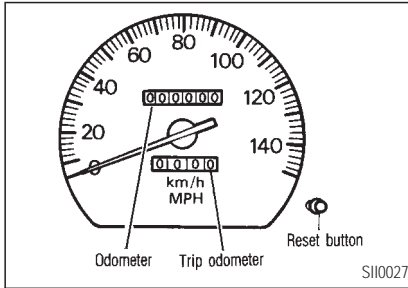

SPEEDOMETER

The speedometer indicates vehicle speed.

ODOMETER

The odometer records the total mileage the vehicle has been driven.

TRIP ODOMETER

The trip odometer records the distance of individual trips. Before each trip, set the trip odometer to zero by pushing the RESET button.

TACHOMETER

The tachometer indicates engine speed in revolutions per minute (r/min).

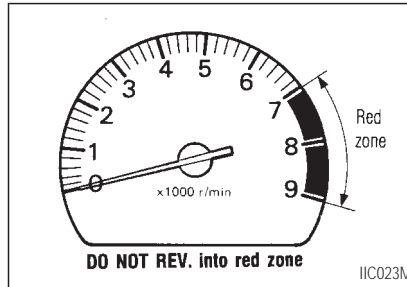

CAUTION

When engine speed approaches the red zone, shift to a higher gear. Operating the engine in the red zone may cause serious engine damage.

INSTRUMENTS AND CONTROLS

ENGINE COOLANT TEMPERATURE GAUGE

The gauge indicates engine coolant temperature.

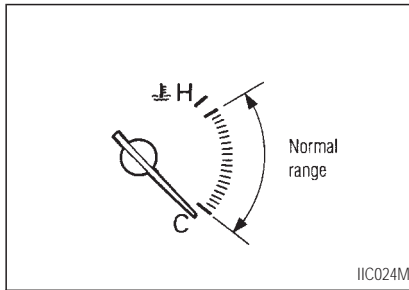

Engine coolant temperature will vary with the outside air temperature and driving conditions.



CAUTION

If the gauge indicates over the normal range, stop the vehicle as soon as safely possible. If the engine is overheated, continued operation of the vehicle may seriously damage the engine. See "In case of emergency" section for immediate action required.

FUEL GAUGE

The gauge indicates the APPROXIMATE fuel level in the tank.

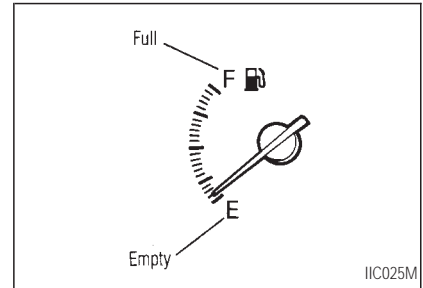



















The gauge may move slightly during braking, turning, acceleration, or going up or down hill.

The gauge needle is designed to remain in approximately the same position, even when the ignition key is turned "OFF".

Refill the fuel tank before the gauge registers Empty.









INSTRUMENTS AND CONTROLS

WARNING/INDICATOR LIGHT AND CHIME



	or		Brake warning light		Supplemental air bag warning light		Malfunction indicator light.		
			Turn signal/hazard indicator lights		Low washer fluid warning light		Engine oil pressure warning light		
			High beam indicator light (Blue)		or		Anti-lock brake system warning light		Low fuel warning light
			Charge warning light		Theft warning light		CRUISE indicator light		
			Door open warning light		Stop/tail warning light				
			Seat belt warning light		A/T check light				

Checking bulbs

Apply the parking brake and turn the ignition key to "ON" without starting the engine. The following lights will come on:

 ,  or  ,  ,  ,  ,  or 

The following lights come on briefly and then go off:

 ' 

If any light fails to come on, it may indicate a burned-out bulb or an open circuit in the electrical system. Have the system repaired promptly.

Engine oil pressure warning light

This light warns of low engine oil pressure. If the light flickers or comes on during normal driving, pull off the road in a safe area, stop the engine **immediately** and call an INFINITI dealer or other authorized repair shop.

INSTRUMENTS AND CONTROLS

The oil pressure warning light is not designed to indicate a low oil level. Use the dipstick to check the oil level. See "Engine oil" in the "Do-it-yourself" section.



CAUTION

Running the engine with the oil pressure warning light on could cause serious damage to the engine almost immediately. Turn off the engine as soon as it is safe to do so. See section 5, In case of emergency.



Charge warning light

If the light comes on while the engine is running, it may indicate that there is something wrong with the charging system. Turn the engine off and check the alternator belt. If the belt is loose, broken, missing or if the

light remains on, see your INFINITI dealer immediately.



CAUTION

Do not continue driving if the belt is loose, broken or missing. See section 5, In case of emergency.



Low fuel warning light

This light comes on when the fuel in the tank is getting low. Refuel as soon as it is convenient, preferably before the fuel gauge reaches "E".

There should be a small reserve of fuel remaining in the tank when the fuel gauge needle reaches "E".



Door open warning light

This light comes on when any of the doors are

not closed securely while the ignition key is "ON".



Supplemental air bag warning light

When the ignition key is in the "ON" or "START" position, the supplemental air bag light will illuminate for about 7 seconds and then turn off. This means the system is operational.

If any of the following conditions occur, the supplemental air bag needs servicing and your INFINITI must be taken to your nearest authorized INFINITI dealer.

1. The supplemental air bag light goes off within 7 seconds.
2. The supplemental air bag light flashes intermittently or remains on (after 7 seconds).
3. The supplemental air bag light does not come on at all.

INSTRUMENTS AND CONTROLS

Unless checked and repaired, the Supplemental Restraint System may not function properly.

For additional details on the Supplemental Air Bag System, see section 2.



WARNING

If the supplemental air bag warning light is on, it could mean that the supplemental air bag system will not operate in an accident.



Seat belt warning light and chime

The light and chime remind you to fasten seat belts. The light illuminates whenever the ignition key is turned to "ON", and will remain illuminated until the driver's seat belt is fastened. (When the ignition key is turned to "ON" with the driver's seat belt fastened, the

light will illuminate for about 7 seconds and then go off.) At the same time, the chime will sound for about six seconds unless the driver's seat belt is securely fastened.

Refer to "Seat belts" in the "Pre-driving checks and adjustments" section for precautions on seat belt usage.

If the seat belt warning light blinks, there may be something wrong with the pre-tensioner seat belt. In this case, the pre-tensioner will not operate properly. Have it checked by your INFINITI dealer.

For additional details on the pre-tensioner seat belt system, see section 2.



Low washer fluid warning light

This light comes on when the washer tank fluid is at a low level. Add washer fluid as necessary. See the "Do-it-yourself" section.



or

BRAKE

Brake warning light

This light functions for both the parking brake and the foot brake systems.

Parking brake indicator:

The light comes on when the parking brake is applied.

Low brake fluid warning:

The light warns of a low brake fluid level. If the light comes on while the engine is running with the parking brake not applied, stop the vehicle and perform the following:

1. Check the brake fluid level. Add brake fluid as necessary. See "Brake and clutch fluid" in the "Do-it-yourself" section.
2. If the brake fluid level is correct:
Have the warning system checked by an INFINITI dealer.

INSTRUMENTS AND CONTROLS



WARNING

- *Your brake system may not be working properly if the warning light is on. Driving could be dangerous. If you judge it to be safe, drive carefully to the nearest service station for repairs. Otherwise, have your vehicle towed.*
- *Pressing the brake pedal with the engine stopped could increase your stopping distance and require greater pedal effort as well as pedal travel.*
- *If the level is below the MINIMUM mark on the brake fluid reservoir, do not drive until the brake system has been checked at an INFINITI dealer.*

ABS

or



Anti-lock brake warning light

If the light comes on while the engine is running, it may indicate there is something wrong with the anti-lock portion of the brake system. In either case, have the system checked by your INFINITI dealer.

If an abnormality occurs in the system, the anti-lock function will cease but the ordinary brakes will continue to operate normally.

If the light comes on while you are driving, contact your INFINITI dealer for repair.

AT
CHECK

A/T check

When the ignition switch is turned ON, the light comes on for 2 seconds. If the light blinks for approximately 8 seconds, it may indicate that there is something wrong with the transmission. Have your INFINITI dealer check and repair the transmission.



Turn signal/hazard indicator lights

The light flashes when the turn signal switch lever or hazard switch is turned on.



Stop/tail warning light

If the light comes on with the engine running and with the light switch on, or when the brake pedal is depressed, one or more stop/tail light bulbs are burned out. Replace the stop/tail light bulb.



High beam indicator light (Blue)

This light comes on when the headlight high beam is on and goes out when the low beam is selected.

CRUISE

CRUISE indicator light

The light comes on while the vehicle speed is controlled by the cruise control system.

INSTRUMENTS AND CONTROLS

Key reminder chime

The chime will sound if the driver side door is opened while the key is left in the ignition switch. Remove the key and take it with you when leaving the vehicle.

Light reminder chime

A chime will sound when the driver side door is opened if the light switch is turned on (ignition switch is turned off).

Turn the light switch off when you leave the vehicle.

Brake pad wear warning

The disc brake pads have audible wear warnings. When a brake pad requires replacement, it will make a high pitched scraping sound when the vehicle is in motion whether or not the brake pedal is depressed. Have the brakes checked as soon as possible if the warning sound is heard.



Malfunction indicator light (MIL)

If the Malfunction indicator light comes on steady or blinks while the engine is running, it may indicate a potential emission control problem.

The Malfunction indicator light will come on in one of two ways:

- Malfunction indicator light on steady — An emission control system malfunction has been detected. Have the vehicle inspected by an authorized INFINITI dealer. You do not need to have your vehicle towed to the dealer.
- Malfunction indicator light blinking — An engine misfire has been detected which may damage the emission control system. To reduce or avoid emission control system damage:
 - * do not drive at speeds above 45 MPH (72 km/h).

- * avoid hard acceleration or deceleration.
- * avoid steep uphill grades.
- * if possible, reduce the amount of cargo being hauled or towed.

The malfunction indicator light may stop blinking and come on steady.

Have the vehicle inspected by an authorized INFINITI dealer. You do not need to have your vehicle towed to the dealer.



CAUTION

Continued vehicle operation without having the emission control system checked and repaired as necessary could lead to poor driveability, reduced fuel economy, and possible damage to the emission control system, which may affect your warranty coverage.

INSTRUMENTS AND CONTROLS

Some conditions may cause the malfunction indicator light to come on steady or blink. For example, running the vehicle out of fuel, which causes the engine to misfire, may cause the malfunction indicator light to come on steady or blink.

If you suspect that you experienced such a condition, drive the vehicle to an authorized INFINITI dealer and have the vehicle inspected. Avoid any unnecessary diagnosis during the service by informing the dealer of the condition that may have occurred.

SECURITY

THEFT WARNING

The theft warning system provides visual and audio alarm signals if parts of the vehicle are disturbed.

How to activate the theft warning system

1. Close all windows.
2. Remove the key from the ignition switch.

3. Close and lock all doors, hood and trunk lid. The doors can be locked either with or without the key.

The system can be activated even if the windows are open.

4. Confirm that the indicator light comes on. The light will glow for about 30 seconds and then go out. The system is now activated. If, during this 30 second time period, the door is unlocked or the ignition key is turned to "ACC" or "ON", the system will not activate.
- **If the key is turned slowly when locking the door, the system may not activate. Furthermore, if the key is turned excessively to the unlock position, the system may be deactivated when the key is removed. If the indicator light fails to glow for 30 seconds, unlock the door once and lock it again.**
 - **Even when the driver and/or passen-**

gers are in the vehicle, the system will activate with all doors, hood, trunk lid and back door locked and ignition key off. Turn the ignition key to "ACC" to turn the system off.

Theft warning system operation

The warning system will give the following alarm:

- The headlights blink and the horn sounds intermittently. In addition, the starter motor will not operate.
- The alarm automatically turns off after 2 to 4 minutes; however, the alarm will reactivate if the vehicle is tampered with again.

The alarm is activated by:

- Unlocking the door or opening the trunk lid without using the key or multi-remote controller. (Even if the door is opened by releasing the door inside lock knob or the trunk lid is opened by operating the trunk

INSTRUMENTS AND CONTROLS

lid release switch, the alarm is activated.)

- Opening the hood.
- Pushing in or pulling out of the key cylinder on the door or trunk lid.

How to stop alarms

The alarm will stop only by unlocking a door or trunk lid with the key. The alarm will not stop if the ignition switch is turned to "ACC" or "ON".

If the system does not operate as described above, have it checked by your INFINITI dealer.

WINDSHIELD WIPER AND WASHER SWITCH

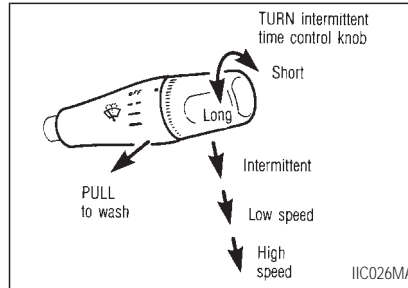

The windshield wiper and washer operates when the ignition key is in the "ACC" or "ON" position.

Push the lever down to operate the wiper. Pull the lever toward you to operate the washer.

Intermittent operation can be adjusted from 4 to 12 seconds by turning the knob.



CAUTION

The following could damage the washer system:

- Do not operate the washer continuously for more than 30 seconds.
- Do not operate the washer if the reservoir tank is empty.



WARNING

In freezing temperatures the washer solution may freeze on the windshield and obscure your vision which may lead to an accident. Warm the windshield with the defroster before you wash the windshield.

INSTRUMENTS AND CONTROLS

REAR WINDOW AND OUTSIDE DOOR MIRROR DEFOGGER SWITCH

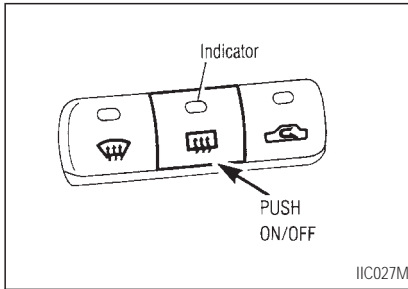

To defog the rear window glass and the outside door mirrors, start the engine and push the switch on. (The indicator light will come on.) Push the switch again to turn the defogger off.

It will automatically turn off in approximately 15 minutes.

CAUTION

When cleaning the inner side of the rear window, be careful not to scratch or damage the rear window defogger.

HEADLIGHT AND TURN SIGNAL SWITCH

Lighting

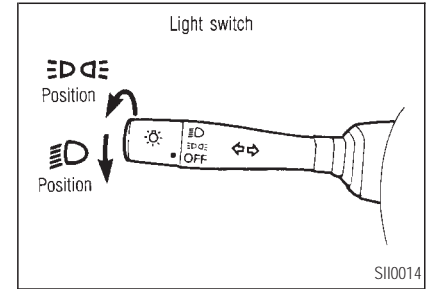

Turn the switch to the “” position:

The parking, front and rear side marker, tail, license plate and instrument lights will come on.

Turn the switch to the “” position:

Headlights will come on and all the other lights remain on.

INSTRUMENTS AND CONTROLS

Daytime running light system (For Canada)

The headlights automatically illuminate at a reduced intensity when the engine is started with the parking brake released. The daytime running lights operate with the headlight switch in the "OFF" position or in the "☰" position. Turn the headlight switch to the "☉" position for full illumination when driving at night.

If the parking brake is applied before the engine is started, the daytime running lights do not illuminate. The daytime running lights illuminate once the parking brake is released. The daytime running lights will remain on until the ignition switch is turned off.

WARNING

When the daytime running light system is active, tail lights on your vehicle will not be on. It is necessary at dusk to turn on your headlights. Failure to do so could cause an accident injuring yourself and others.

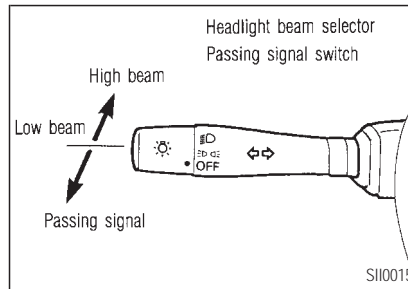

To select the high beam, push the lever for-

ward. Pull it back to select the low beam.

Passing signal

Pulling the lever toward you will flash the headlight high beam.

Turn signal

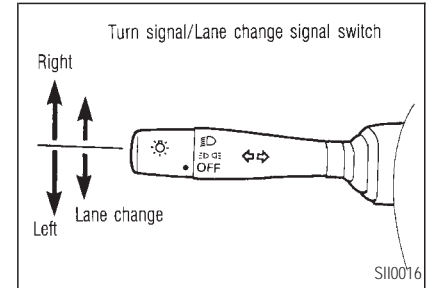

Move the lever up or down to signal the turning direction. When the turn is completed, the turn signals cancel automatically.

Lane change signal

To indicate a lane change, move the lever up

INSTRUMENTS AND CONTROLS

or down to the point where lights begin flashing.

INSTRUMENT BRIGHTNESS CONTROL

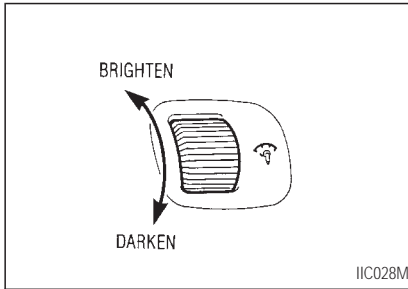

The instrument brightness control operates when the head light switch is in the "☰" or "☷" position.

Turn the control to adjust the brightness of the instrument panel lights.

When the control is turned in the upper direction until a click sound is heard, the light

intensity will be at maximum. When the control is turned in the lower direction until a click sound is heard, the light will be turned off.

HAZARD WARNING FLASHER SWITCH

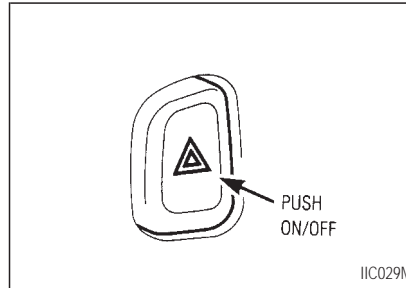

Push the switch on to warn other drivers when you must stop or park under emergency conditions. All turn signal lights will flash.



WARNING

- *When stalled or stopped on the roadway under emergency conditions, move the vehicle well off the road.*
- *Do not use the switch while moving on the highway unless unusual circumstances force you to drive so slowly that your vehicle might become a hazard to other traffic.*
- *Turn signals do not work when the switch is operating.*

The flasher can be actuated with the ignition switch either off or on.

Some state laws may prohibit the use of the hazard warning flasher switch while driving.

INSTRUMENTS AND CONTROLS

HEATED SEAT

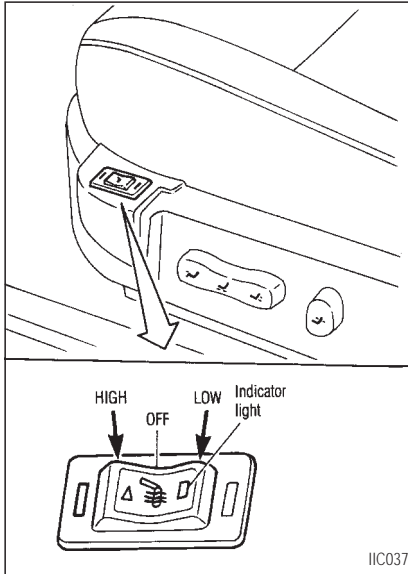

The front seats are warmed by built-in heaters. The switches located on the side part of the seats can be operated independently of each other.

1. Start the engine.

The battery could run down if the heater is operated while the engine is not running.

2. Push the "LO" or "HI" position of the switch, as desired, depending on the temperature. The indicator light in the switch will illuminate.

The heater is controlled by a thermostat, automatically turning the heater on and off. The indicator light will remain on as long as the switch is on.

3. When the vehicle's interior is warmed or before you leave the vehicle, be sure to turn the switch off.



CAUTION

Do not use the seat heater for a long time or when no one is seated there.

- *Do not put anything on the seat which insulates heat, such as a blanket, cushion, seat cover, etc. Otherwise, the seat may become overheated.*
- *Do not place anything hard or heavy on the seat or pierce it with a pin or similar object. This may result in damage to the heater.*
- *Any liquid spilled on the heating seat should be immediately wiped up with a dry cloth.*
- *When cleaning the seat, never use benzine, thinner, or any similar materials.*

INSTRUMENTS AND CONTROLS

- *If any abnormalities are found or the heating seat does not operate, turn the switch OFF and have the system checked by your INFINITI dealer.*

CIGARETTE LIGHTERS AND ASHTRAYS

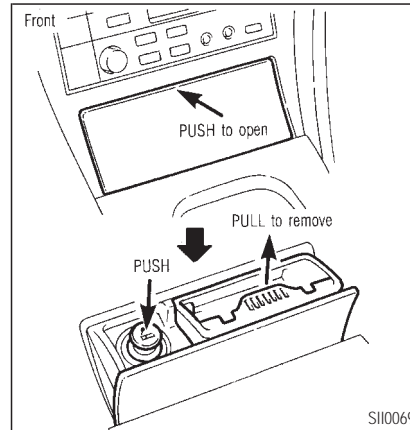

The cigarette lighter operates when the ignition switch is in the "ACC" or "ON" position.

Push the lighter in all the way, then release it. When the lighter is heated, it will spring out.

Return the lighter to its original position after use.

To empty the ashtray, pull up on the horizontal bar and remove the tray.

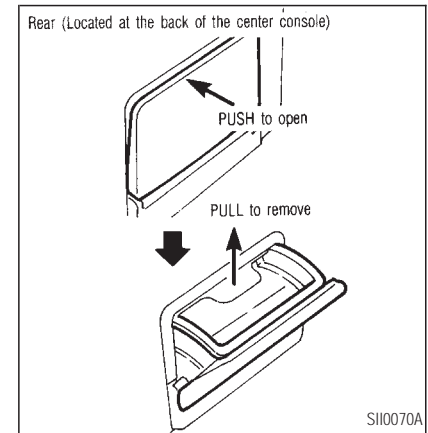

INSTRUMENTS AND CONTROLS

WARNING

The cigarette lighter should not be used while driving in order that full attention may be given to the driving operation.

CAUTION

The cigarette lighter socket is a power source for the cigarette lighter element only. The use of the cigarette lighter socket as a power source for any other accessory is not recommended.

CUP HOLDER

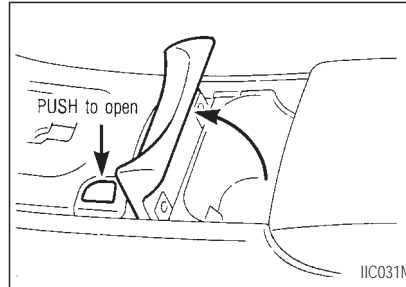

To open, push the cup holder opener switch.

To close, lower the cup holder lid and push down lightly.

WARNING

- The cup holder should not be used while driving in order that

full attention may be given to the driving operation.

CAUTION

- Avoid abrupt starting and braking when the cup holder is being used to prevent spilling the drink. If the liquid is hot, it can scald you or your passenger.
- Use only soft cups in the cup holder. Hard objects can injure you in an accident.

INSTRUMENTS AND CONTROLS

BOOK HOLDER

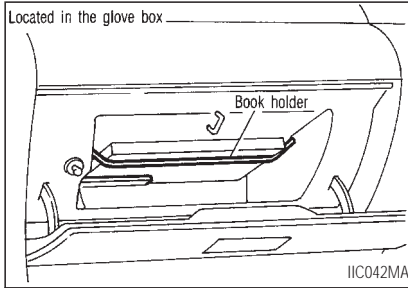

CARGO NET

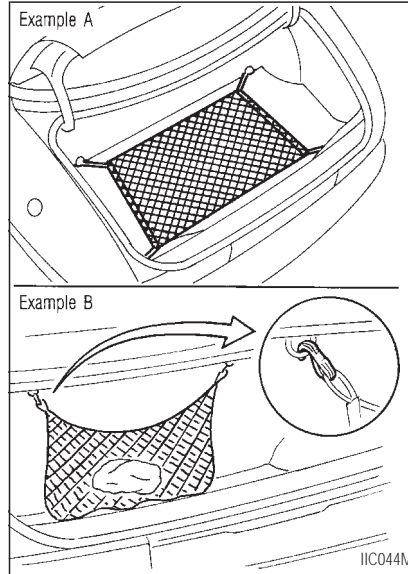

- Do not put heavy objects in the cargo net. The net is designed only to hold light packages or objects in place while driving.

INSTRUMENTS AND CONTROLS

POWER WINDOW



- ***Make sure that all passengers have their hands, etc. inside the vehicle before closing the windows. Use the window lock switch to prevent unexpected use of the power windows.***
- ***Do not leave children unattended inside the vehicle. They could unknowingly activate switches or controls and become trapped in a window. Unattended children could become involved in serious accidents.***

The power windows only operate when the ignition key is in the "ON" position.

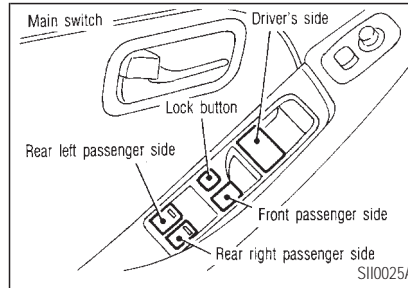

To open or close the window, push down or pull up the switch and hold it. The main switch (driver side switches) will open or close all the windows.

Locking passenger's window

When the lock button is pushed in, only the driver side window can be opened or closed. Push it in again to cancel.

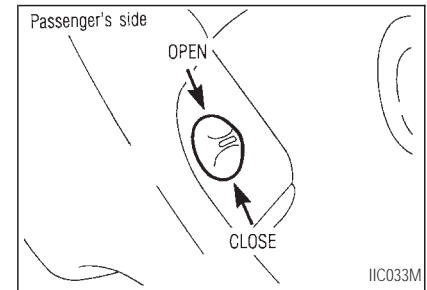

The passenger side switch will open or close only the corresponding window. To open or close the window, hold the switch down or up.

INSTRUMENTS AND CONTROLS

POWER WINDOW AUTOMATIC SWITCH

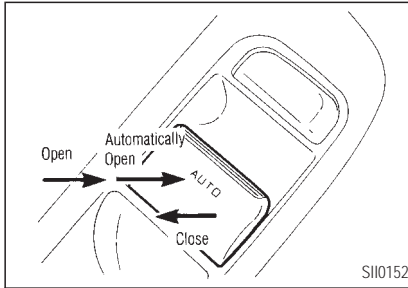

To fully open the driver side window, completely press down the switch and release it; it need not be held. The window will automatically open all the way. To stop the window, just pull up the switch toward the "CLOSE" side.

A light press on the switch will cause the window to open until the switch is released.

SUNROOF

The sunroof will only operate when the ignition key is in the "ON" position.

Sliding the sunroof

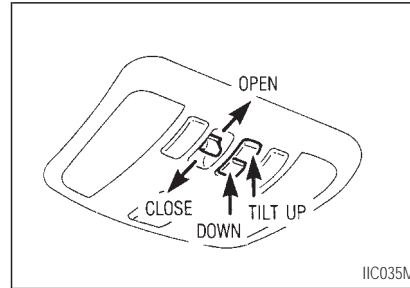

To open the roof, keep pressing the switch to the "OPEN" side.

To close the roof, keep pressing the switch to the "CLOSE" side.

Tilting the sunroof

To tilt up, first close the sunroof, then keep

pushing the "UP" side of the tilt switch. To tilt down the sunroof, keep pushing the "DOWN" side.



WARNING

- In an accident you could be thrown from the vehicle through an open sunroof. Always use seat belts and child restraints properly.
- Do not allow anyone to stand up or extend any portion of their body out of the opening while the vehicle is in motion or while the sunroof is closing.

INSTRUMENTS AND CONTROLS

CAUTION

- Remove water drops, snow, ice or sand from the sunroof before opening.
- Do not place any heavy object on the sunroof or surrounding area.

IF THE SUNROOF DOES NOT CLOSE

Have your INFINITI dealer check and repair the sunroof.

CLOCK

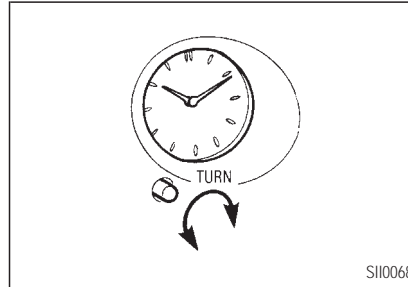

The time can be adjusted by turning the knob.

INTERIOR LIGHT

The interior light has a three-position switch.

When the switch is in the center "O" position, the light will illuminate when a door is opened.

CAUTION

Leaving the interior light switch in the ON position for extended periods of time will result in a discharged battery.

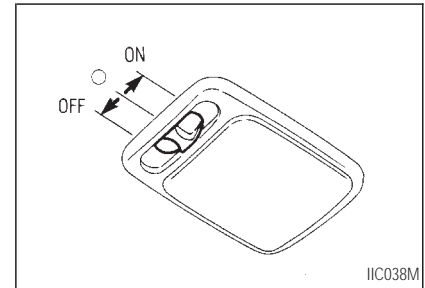

INSTRUMENTS AND CONTROLS

Illuminated entry system

When the light switch is set at the center “○” position and the front door handle is pulled and released once, the interior light and ignition key light will come on and gradually go out. This system is helpful at night to locate the ignition key slot or check the vehicle interior.

VANITY MIRROR LIGHT

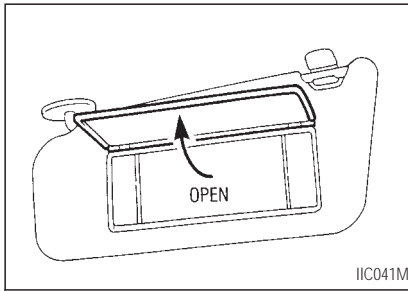

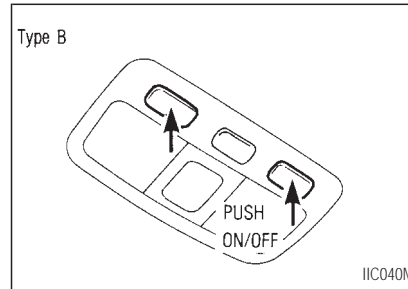
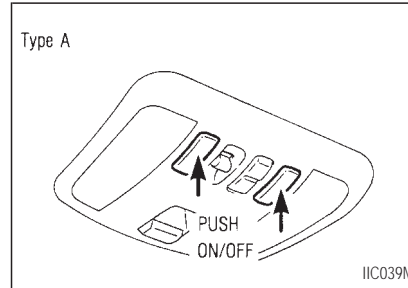

The light on the vanity mirror will turn on when the cover on the vanity mirror is opened.

PERSONAL LIGHT

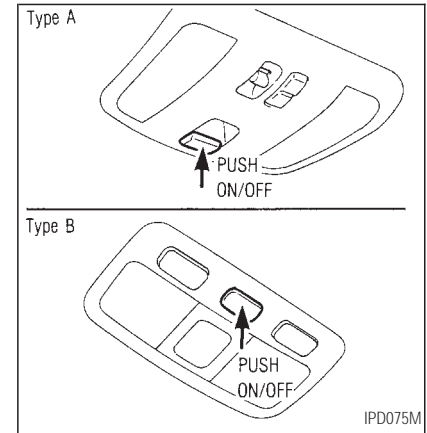

CONSOLE LIGHT



With the console light switch turned on, the light will come on by turning the headlight and turn signal switch to the “ ” or “ ” position. The light is designed to illuminate the switches, etc. on the center console and the automatic transmission shift

INSTRUMENTS AND CONTROLS

lever to make them easier to see and use at night.

Normally, keep the console light switch turned on. Switch off the console light when not needed.

2 PRE-DRIVING CHECKS AND ADJUSTMENTS

Key	2-2	Warning labels	2-25
Door locks	2-2	Supplemental air bag warning light	2-25
Multi-remote control system	2-5	Seat belts	2-27
Hood release	2-9	Child restraints for infants and small children.....	2-35
Glove box lock	2-10	Tilting steering wheel	2-44
Trunk lid lock	2-10	Outside mirror remote control	2-44
Fuel filler lid lock	2-11	Foldable outside mirrors	2-45
Seats	2-13	Automatic anti-dazzling inside mirror	2-45
Supplemental restraint system (Supplemental air bag system)	2-16	Center sunvisor	2-45

PRE-DRIVING CHECKS AND ADJUSTMENTS

KEY

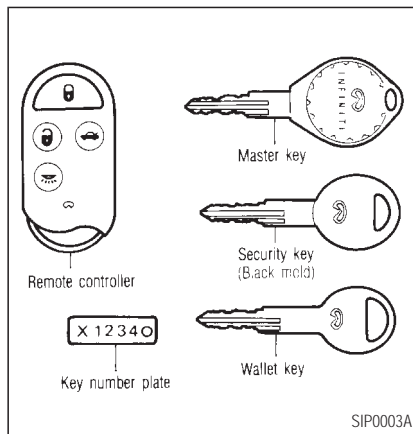

The master key and wallet key can be used for all the locks. The security key cannot be used for the trunk lid or glove box locks. To protect belongings when you leave a key with someone, give them the security key only. Never leave this key in the vehicle.

Record the key number on the key number plate and keep it in a safe place (such as your wallet), NOT IN THE CAR. A key number plate is supplied with your key. Keep the plate in a safe place. INFINITI does not record key numbers so it is very important to keep track of your key number plate.

A key number is only necessary when you have lost all keys and do not have one to duplicate from. If you still have a key, this key can be duplicated by your INFINITI dealer or a lock smith shop.

DOOR LOCKS

Locking front doors with key

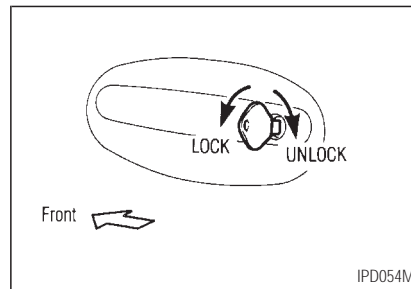

To lock the door, turn the key toward the front of the vehicle.

To unlock, turn it toward the rear.

Locking the front door will simultaneously lock the other doors.

PRE-DRIVING CHECKS AND ADJUSTMENTS

Locking the doors without key

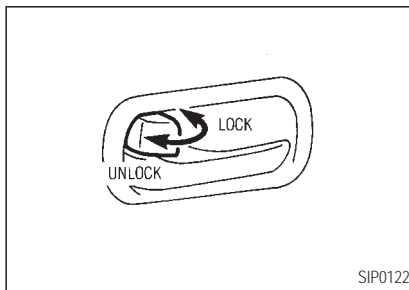

To lock from the outside without a key, move the inside lock knob to the "LOCK" position. Then close the door.

When locking the door this way, be certain not to leave the key inside the vehicle.



WARNING

- Always have the doors locked

while driving. Along with the use of seat belts, this provides greater safety in the event of an accident by helping to prevent persons from being thrown from the vehicle. This also helps keep children and others from unintentionally opening the doors, and will help keep out intruders.

- Before opening any door, always look for and avoid oncoming traffic.
- Do not leave children unattended inside the vehicle. They could unknowingly activate switches or controls. Unattended children could become involved in serious accidents.

CHILD SAFETY REAR DOOR LOCK

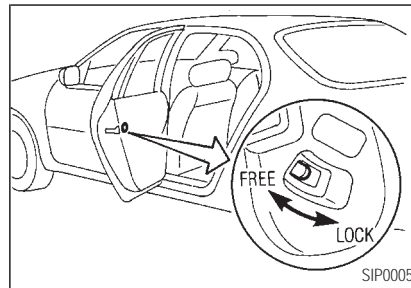

Child safety locking helps prevent doors from being opened accidentally, especially when small children are in the vehicle.

When the lever is in the lock position, the rear door can be opened only from the outside.

PRE-DRIVING CHECKS AND ADJUSTMENTS

POWER DOOR LOCK

The power door lock system allows you to lock or unlock all doors simultaneously.

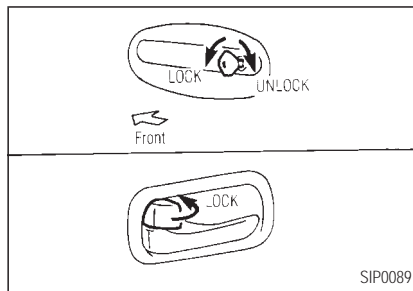

- Turning the front door key to the front of the vehicle will lock all doors.
- Turning the front door key one time to the rear of the vehicle will unlock the corresponding door. From that position, returning the key to Neutral (where the key can only be removed and inserted.) and turning it to the rear again within 3 seconds

will unlock all doors.

- Pushing the front door lock knob in will lock all doors.

If the front doors are open with the key in the ignition when the inside lock knob is set to the lock position, all door knobs will unlock. When the open front door is closed, all the knobs will lock then quickly unlock automatically.

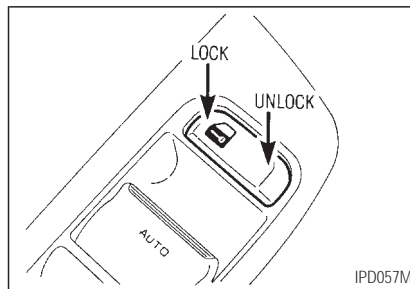

- Operating the lock-unlock switch will lock or unlock all doors.



WARNING

- Before opening the door, always look for and avoid oncoming traffic.
- Do not leave children unattended inside the vehicle. They could unknowingly activate switches or controls. Unattended children could become involved in serious accidents.

PRE-DRIVING CHECKS AND ADJUSTMENTS

MULTI-REMOTE CONTROL SYSTEM

It is possible to lock/unlock all doors, to open the driver's and front passenger's windows, to release the trunk lid and to turn on or off the interior light by using the remote controller from outside the car.

Be sure to remove the key from the vehicle before locking the doors and leaving it.

The remote controller can operate at a distance of approximately 49 ft (15 m) from the vehicle. (The effective distance depends upon the conditions around the vehicle.)

As many as four remote controllers can be used with one vehicle. For information concerning the purchase and use of additional remote controllers, contact your INFINITI dealer.



CAUTION

Listed below are conditions or occurrences which will damage the remote controller.

- *Do not allow the remote controller to become wet.*
- *Do not drop the remote controller.*
- *Do not strike the remote controller sharply against another object.*
- *Do not place the remote controller for an extended period in an area where temperatures exceed 140°F (60°C).*

PRE-DRIVING CHECKS AND ADJUSTMENTS

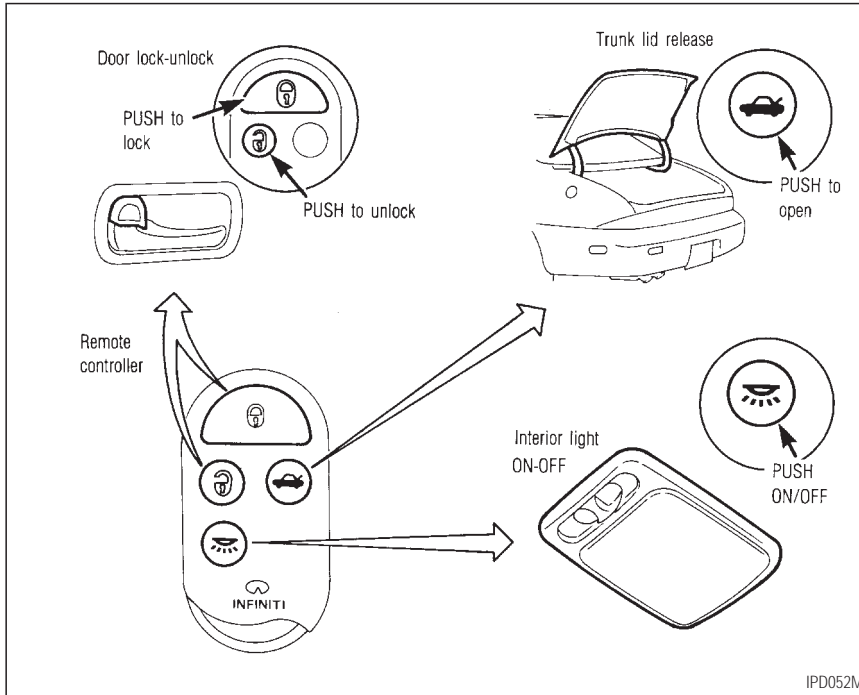

HOW TO USE MULTI-REMOTE CONTROL SYSTEM

Locking doors

1. Remove the ignition key.
 2. Close all doors.
 3. Push the lock button on the remote controller.
 4. All doors will lock.
 5. The hazard indicator flashes twice.
- When the lock button is pushed with all doors locked, the hazard indicator flashes twice as a reminder that the doors are already locked.

PRE-DRIVING CHECKS AND ADJUSTMENTS

Unlocking doors

1. Push the unlock button on the remote controller.
2. Only the driver side door will unlock. Push the unlock button on the remote controller again within 3 seconds.
3. All doors will unlock.
4. The interior light will stay on for 30 seconds when the interior light switch is in the center "O" position.

The interior light can be turned off without waiting for 30 seconds by inserting the key into the ignition or by locking the doors with the remote controller or by pushing the interior light button.

Releasing the trunk lid

1. Push the trunk lid release button for longer than 1.0 seconds.
2. The trunk lid will open.

The trunk will not open with the trunk lid release cancel switch turned to OFF. (See "Trunk lid lock" for details.)

Using the interior light

1. Push the interior light button.
2. The interior light will stay on for 30 seconds when the interior light switch is in the center "O" position.

The interior light can be turned off without waiting for 30 seconds by locking the doors with the remote controller or by pushing the interior light button or by inserting the key into the ignition.

Using the panic alarm

If you are near your vehicle and feel threatened, you may activate the alarm to call attention as follows:

1. Push the lock button on the remote controller for longer than 1.5 seconds.
2. The theft warning alarm and headlight will

stay on for 30 seconds.

3. The alarm will stop when any of the key functions are used.

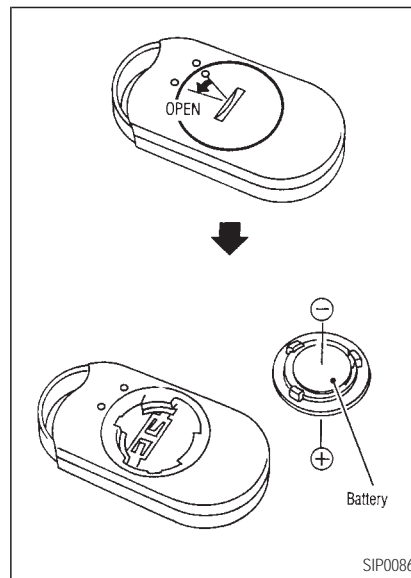

PRE-DRIVING CHECKS AND ADJUSTMENTS

BATTERY REPLACEMENT

Replace the battery as follows:

1. Open the lid using a suitable tool.
2. Replace the battery with a new one.
Recommended battery: Sanyo CR2025 or equivalent
3. Close the lid securely.
4. Press the key button two or three times to check its operation.

If the battery is removed for any reason other than replacement, perform step 4 above.

- **An improperly disposed battery can hurt the environment. Always confirm local regulations for battery disposal.**
- **The remote controller is water-proof; however, if it does get wet, immediately wipe completely dry.**

- **The operational range of the remote controller extends to approximately 49 ft (15 m) from the vehicle. This range may vary with conditions.**

FCC Notice:

Changes or modifications not expressly approved by the manufacturers compliance could void the user's authority to operate the equipment.

This device complies with Part 15 of the FCC Rules and RSS-210 of Industry Canada.

Operation is subject to the following two conditions: (1) This device may not cause harmful interference, and (2) this device must accept any interference received, including interference that may cause undesired operation of the device.

PRE-DRIVING CHECKS AND ADJUSTMENTS

HOOD RELEASE

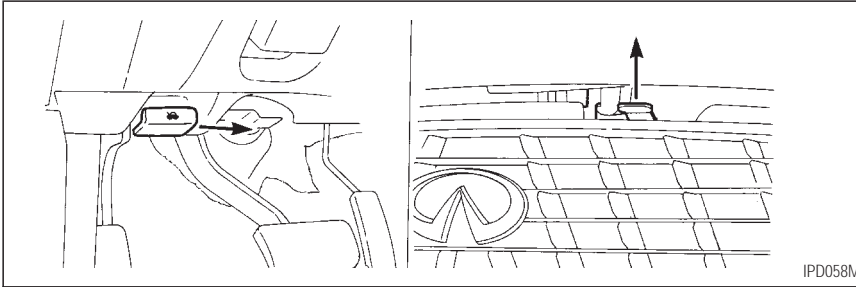

1. Pull the hood lock release handle located below the instrument panel; the hood will then spring up slightly.
2. Pull the lever at the front of the hood with your fingertips and raise the hood.
3. When closing the hood, slowly close the hood and make sure it locks into place.

WARNING

- ***Make sure the hood is completely closed and latched before driving. Failure to do so could cause the hood to fly open and result in an accident.***

- ***If you see steam or smoke coming from the engine compartment, to avoid injury, do not open the hood.***

PRE-DRIVING CHECKS AND ADJUSTMENTS

GLOVE BOX LOCK

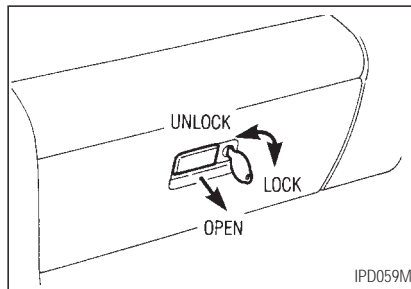

When locking or unlocking the glove box, use the master key and wallet key.

The glove box may be opened by pulling the handle.

CAUTION

Keep the glove box lid closed while driving to help prevent injury in an accident or a sudden stop.

TRUNK LID LOCK

Trunk lid release switch operation

The trunk lid release switch is located on the driver's side door panel.

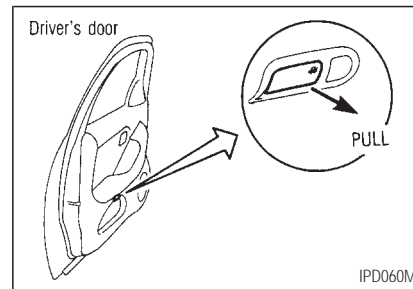

To open the trunk lid, pull the release switch. To close, push the trunk lid down securely.

PRE-DRIVING CHECKS AND ADJUSTMENTS

Key operation

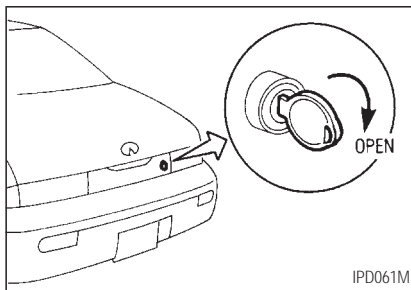

To open the trunk lid, turn the key clockwise. To close, lower and push the trunk lid down securely.



WARNING

Do not drive with the trunk lid open. This could allow dangerous exhaust gases to be drawn into the vehicle.

See "Exhaust gas" in the "Starting and driving" section.

TRUNK LID RELEASE CANCEL SWITCH

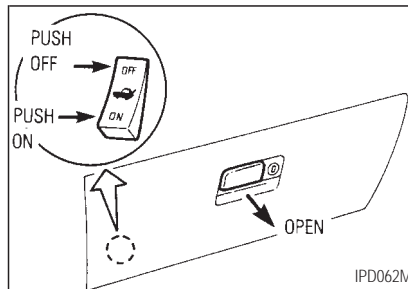

When the cancel switch located inside the glove box is "OFF", the trunk lid cannot be opened with the trunk lid release switch or the remote controller. It can be opened only with the master key or wallet key.

FUEL FILLER LID LOCK

Opener switch

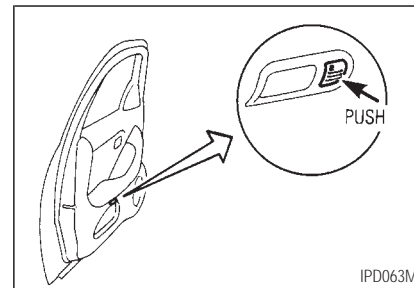

To open the fuel filler lid, push the opener switch. To lock, close the fuel filler lid securely.

PRE-DRIVING CHECKS AND ADJUSTMENTS

FUEL FILLER CAP

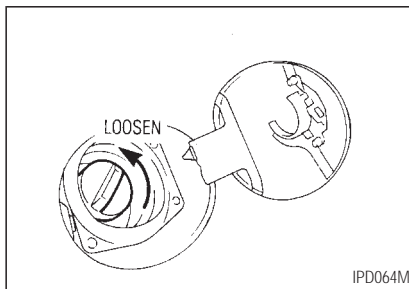

The fuel filler cap is a screw-on ratcheting type. Tighten the cap clockwise until ratcheting clicks are heard.



WARNING

- Gasoline is extremely flammable and highly explosive under certain conditions. You could be burned or seriously injured if it is

misused or mishandled. Always stop the engine and do not smoke or allow open flames or sparks near the vehicle when refueling.

- Fuel may be under pressure. Turn the cap one-half turn and wait for any “hissing” sound to stop, to prevent fuel from spraying out and possible personal injury. Then remove the cap.
- Use only a genuine fuel filler cap as a replacement. It has a built-in safety valve needed for proper operation of the fuel system and emission control system. An incorrect cap can result in a serious malfunction and possible injury.



CAUTION

If fuel is spilled on the car body, flush it away with water to avoid paint damage.

FUEL FILLER CAP HOLDER

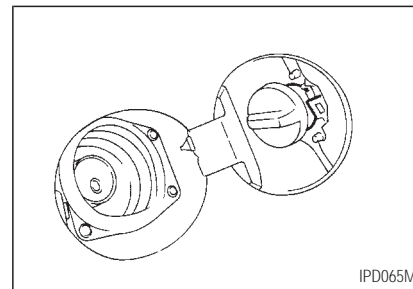

Put the fuel filler cap on the cap holder while refueling.

PRE-DRIVING CHECKS AND ADJUSTMENTS

SEATS

POWER SEAT

WARNING

- Do not adjust the driver's seat while driving in order that full attention may be given to the driving operation.
- The seatback should not be reclined any more than needed for comfort. Seat belts are most effective when the occupant sits well back and straight up in the seat. If the seatback is reclined, the risk of sliding under the lap belt and being injured is increased.
- Do not leave children unattended inside the vehicle. They could

unknowingly activate switches or controls. Unattended children could become involved in serious accidents.

Operating tips

- The power seat motor has an auto-reset overload protection circuit. If the motor stops during operation, wait 30 seconds, then reactivate the switch.
- Do not operate the power seat for a long period of time when the engine is off. This will discharge the battery.

Forward and backward

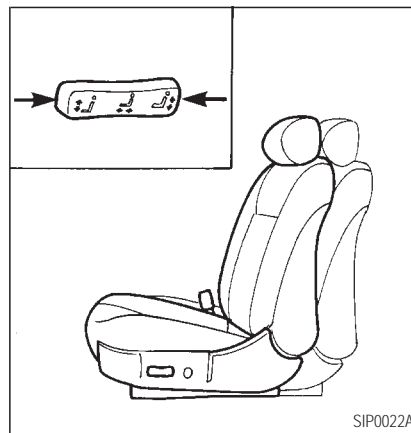

Pressing the switch forward or backward will slide the seat forward or backward to the desired position.

PRE-DRIVING CHECKS AND ADJUSTMENTS

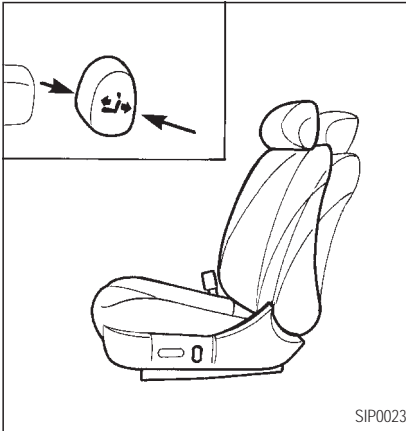

Reclining

Moving the recline switch forward or backward will move the seatback forward or backward to the desired position.

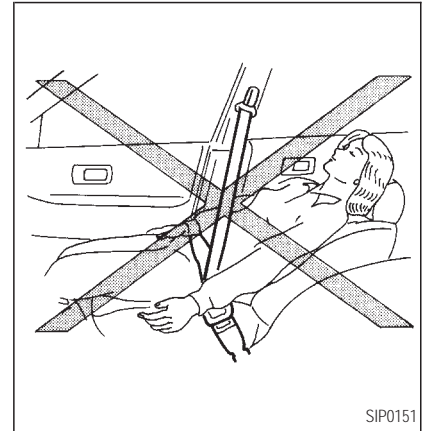

WARNING

Do not ride in a moving vehicle when the seatback is reclined. This can be dangerous. The shoulder belt will

PRE-DRIVING CHECKS AND ADJUSTMENTS

not be against your body. In an accident you could be thrown into it and receive neck or other serious injuries. You could also slide under the lap belt and receive serious internal injuries.

For most effective protection when the vehicle is in motion, the seat should be upright. Always sit well back in the seat and adjust the seat belt properly. See "Precautions on seat belt usage" later in this chapter.

Seat lifter

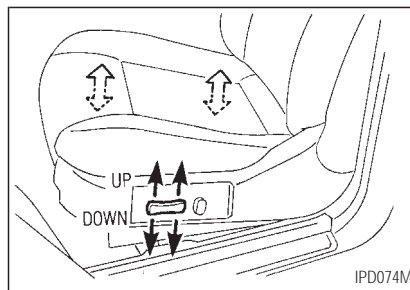

Pull or lower either side of the switch to adjust the seat cushion to the desired angle and height.

Lumbar support (Driver's seat)

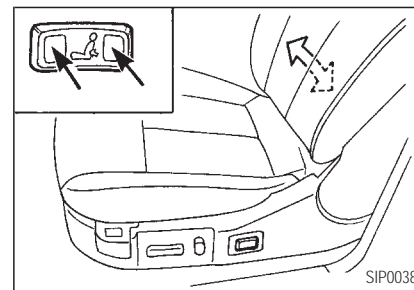

Push either side of the switch to adjust the seat lumbar area.

PRE-DRIVING CHECKS AND ADJUSTMENTS

HEAD RESTRAINTS

Adjust the top of the head restraint level with the top of your ears.

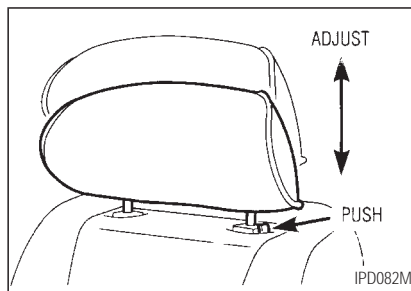

To raise the head restraint, just pull it up. To lower, push the lock knob and push the head restraint down.



WARNING

Head restraints should be adjusted

properly as they may provide significant protection against injury in an accident. Do not remove them. Check the adjustment after someone else uses the seat.

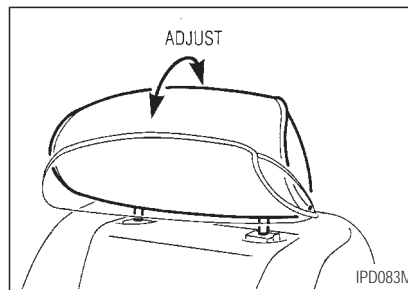

To adjust the head restraint, push it forward or rearward as shown.

SUPPLEMENTAL RESTRAINT SYSTEM (SUPPLEMENTAL AIR BAG SYSTEM)

This Supplemental Restraint System section contains important information concerning the driver and passenger supplemental air bags and pre-tensioner seat belt. The Supplemental Restraint System Air Bag can help reduce impact force to the driver and to the front passenger in certain frontal collisions. The supplemental air bags are designed to **supplement** the crash protection provided by the driver and front passenger seat belts and are **not a substitute** for them. Seat belts should always be correctly worn and the driver and front passenger seated a suitable distance away from the steering wheel and instrument panel. (See "Seat belts" for instructions and precautions on seat belt usage.)

The supplemental air bags and pre-tensioner seat belts will operate only

PRE-DRIVING CHECKS AND ADJUSTMENTS

when the ignition switch is in the "ON" or "START" position.



WARNING

- *The supplemental air bags ordinarily will not inflate in the event of a side impact, rear impact, roll over, or lower severity frontal collision. Always wear your seat belts to help reduce the risk or severity of injury in various kinds of accidents.*

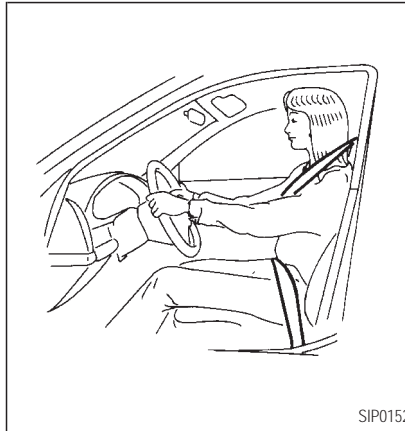

SIP0152

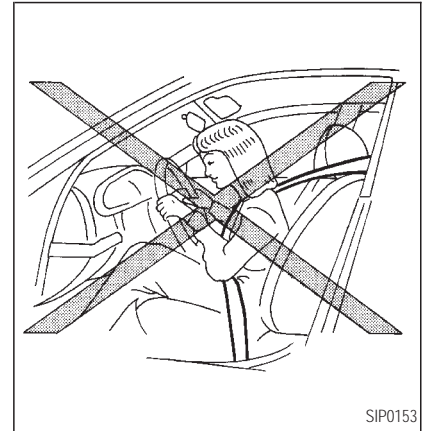

SIP0153



WARNING

- *The seat belts and the supplemental air bags are most effective when you are sitting back and upright in the seat. Supplemental*

air bags inflate with great force. If you are unrestrained, leaning forward, sitting sideways or out of position in any way, you are at greater risk of injury or death in a crash and may also receive seri-

PRE-DRIVING CHECKS AND ADJUSTMENTS



ous or fatal injuries from the supplemental air bag if you are up against it when it inflates. Always sit back against the seat-back and as far away as practical from the steering wheel or instru-

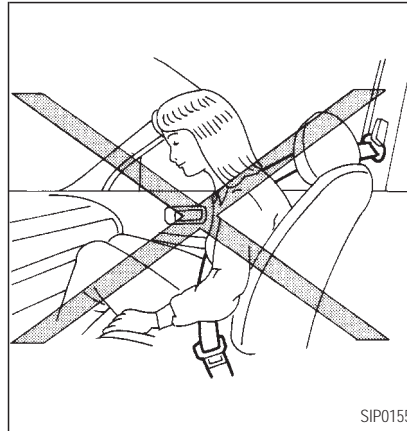

ment panel. Always use the seat belts.

- *Keep hands on the outside of the steering wheel. Placing them inside the steering wheel rim could*

increase the risk that they are injured when the supplemental air bag inflates.

PRE-DRIVING CHECKS AND ADJUSTMENTS

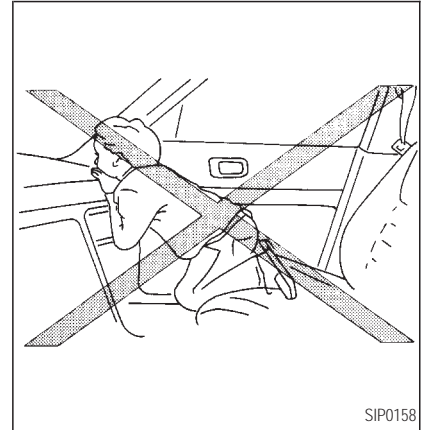
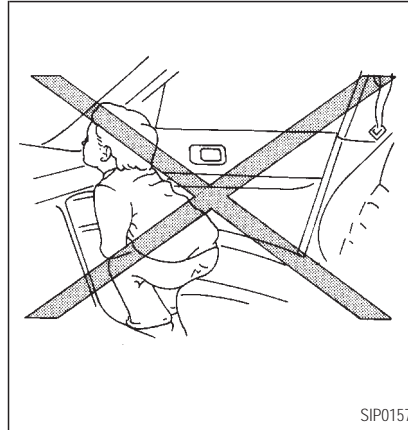
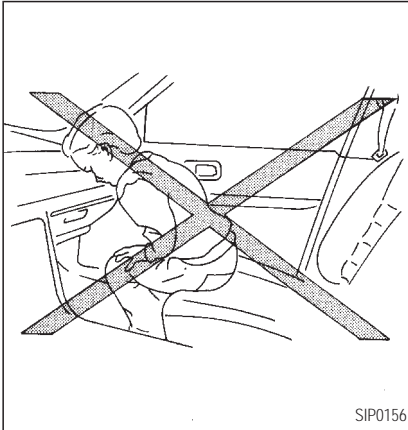

PRE-DRIVING CHECKS AND ADJUSTMENTS

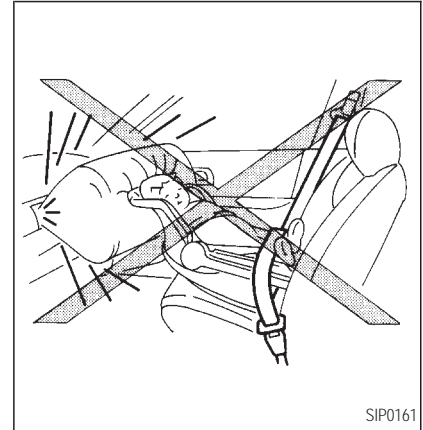
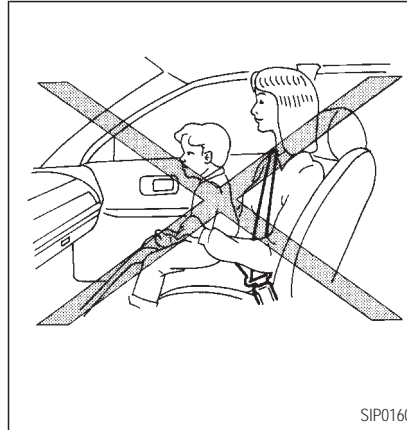
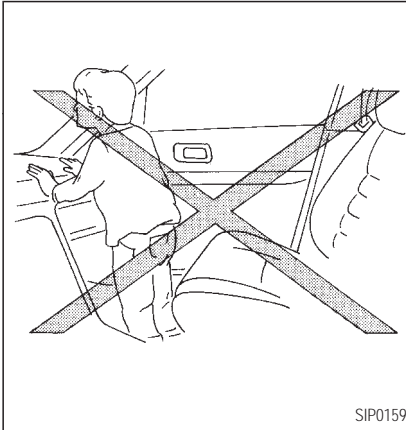

WARNING

- Never let children ride unrestrained. Do not attempt to hold them in your lap or arms. Some examples of dangerous riding po-

sitions are shown in the previous illustrations.

- Children may be severely injured or killed when the supplemental air bag inflates if they are not

properly restrained.

- Also, never install a rear-facing child restraint in the front seat. An inflating supplemental air bag could seriously injure or kill your

PRE-DRIVING CHECKS AND ADJUSTMENTS

child. See “Child restraints for infants and small children” for details.

Pre-tensioner seat belt system

The front seat pre-tensioner seat belt system activates in conjunction with the supplemental air bag. Working with the seat belt retractor, it helps tighten the seat belt the instant the vehicle becomes involved in certain types of frontal collisions, thereby restraining seat occupants.

The pre-tensioner is encased with the seat belt's retractor. These seat belts are used the same as conventional seat belts.

When the pre-tensioner seat belt activates, smoke is released and a loud noise may be heard. The smoke is not harmful, but care should be taken not to inhale it as it may cause irritation and choking.



WARNING

- *The pre-tensioner seat belt cannot be reused after activation. It must be replaced together with the retractor as a unit.*
- *If the vehicle becomes involved in a frontal collision but the pre-tensioner is not activated, be sure to have the pre-tensioner system checked and, if necessary, replaced by your INFINITI dealer.*

If any abnormality occurs in the pre-tensioner system, the seat belt warning light will flash intermittently after the ignition key is turned to the “ON” or “START” position. In this case, the pre-tensioner seat belt will not function properly.

When selling your vehicle, we request

that you inform the buyer about the pre-tensioner seat belt system and guide the buyer to the appropriate sections in this Owner's Manual.



WARNING

- *No unauthorized changes should be made to any components or wiring of the pre-tensioner seat belt system. This is to prevent accidental retraction of the pre-tensioner seat belt or damage to the pre-tensioner seat belt operation. Tampering with the pre-tensioner seat belt system may result in serious personal injury.*
- *Work around and on the pre-tensioner system should be done by an authorized INFINITI dealer. Installation of electrical equip-*

PRE-DRIVING CHECKS AND ADJUSTMENTS

ment should also be done by an authorized INFINITI dealer. Unauthorized electrical test equipment and probing devices should not be used on the pre-tensioner seat belt system.

- If you need to dispose of the pre-tensioner or scrap the vehicle, contact an authorized INFINITI dealer. Correct pre-tensioner disposal procedures are set forth in the appropriate INFINITI Service Manual. Incorrect disposal procedures could cause personal injury.

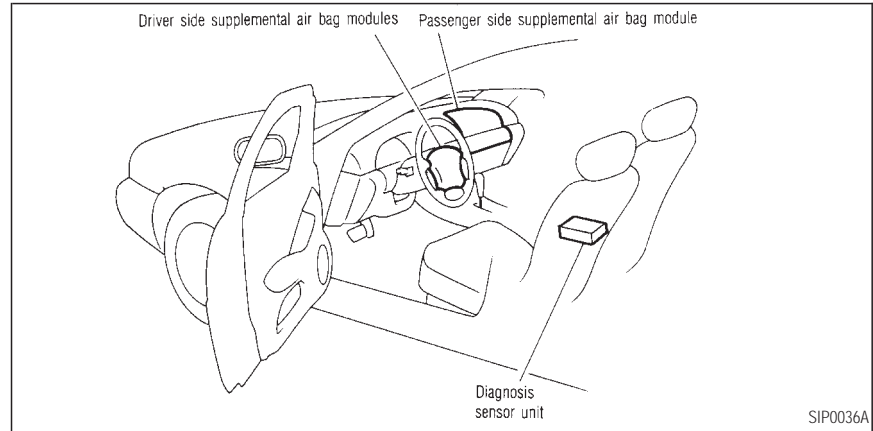

Supplemental air bag system

The driver supplemental air bag is located in the center of the steering wheel; the front passenger supplemental air bag is mounted in the dashboard above the glove box. The supplemental air bags are designed to inflate in higher severity frontal collisions, although

it may inflate if the forces in another type of collision are similar to those of a higher severity frontal impact. It may not inflate in certain frontal collisions. Vehicle damage (or lack of it) is not always an indication of proper supplemental air bag operation.

When the supplemental air bag inflates, a fairly loud noise may be heard, followed by

PRE-DRIVING CHECKS AND ADJUSTMENTS

release of smoke. This smoke is not harmful and does not indicate a fire, but care should be taken not to inflate it, as it may cause irritation and choking. Those with a history of breathing trouble should get fresh air promptly.

Supplemental air bags, along with the use of seat belts, help to cushion the impact force on the face and chest of the occupant. They can help save lives and reduce serious injuries. However, an inflating supplemental air bag may cause facial abrasions or other injuries. Supplemental air bags do not provide restraint to the lower body.

The seat belts should be correctly worn and the driver and passenger seated upright as far as practical away from the steering wheel or dash board. Since the supplemental air bags inflate quickly in order to help protect the occupant, the force of the supplemental air bag inflating can increase the risk of injury if the occupant is too close to or is against the supplemental air bag module during inflation. The supplemental air bag will deflate quickly

after the collision is over.

The supplemental air bags will operate only when the ignition switch is in the "ON" or "START" position.



WARNING

- *Do not attach any objects to the steering wheel pad and to the instrument panel. Also, do not place any objects between any occupant and the steering wheel or instrument panel. Such objects may become dangerous projectiles and cause injury if the supplemental air bag inflates.*
- *Right after inflation, several supplemental air bag system components will be hot. Do not touch them; you may severely burn yourself.*

- *No unauthorized changes should be made to any components or wiring of the supplemental air bag system. This is to prevent accidental inflation of the supplemental air bag or damage to the supplemental air bag system.*
- *Do not make unauthorized changes to your vehicle's electrical system, suspension system or front end structure. This could affect proper operation of the supplemental air bag system.*
- *Tampering with the supplemental air bag system may result in serious personal injury. Tampering includes changes to the steering wheel and the instrument panel assembly by placing material*

PRE-DRIVING CHECKS AND ADJUSTMENTS

over the steering wheel pad and above the instrument panel, or by installing additional trim material around the supplemental air bag system.

- *Work around and on the supplemental air bag system should be done by an authorized NISSAN dealer. Installation of electrical equipment should also be done by an authorized INFINITI dealer. The yellow SRS wiring should not be modified or disconnected. Unauthorized electrical test equipment and probing devices should not be used on the supplemental air bag system.*

- *The SRS wiring harnesses are covered with yellow insulation either just before the harness connectors or over the complete harness for easy identification.*

When selling your vehicle, we request that you inform the buyer about the supplemental air bag system and guide the buyer to the appropriate sections in this Owner's Manual.

PRE-DRIVING CHECKS AND ADJUSTMENTS

WARNING LABELS

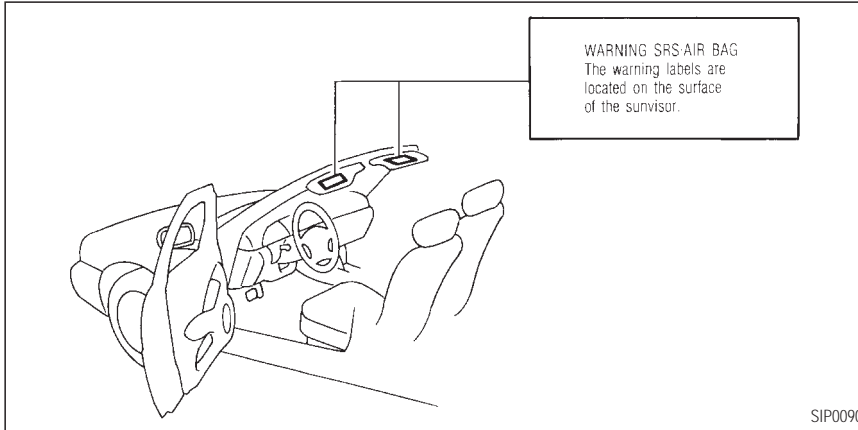

The warning labels about the supplemental air bag system are placed in the vehicle.

SUPPLEMENTAL AIR BAG WARNING LIGHT

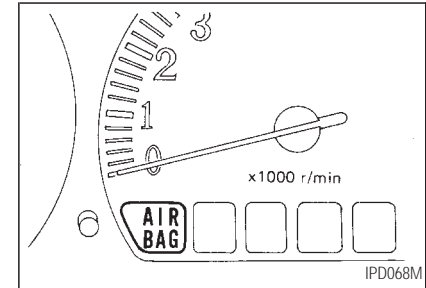

The supplemental air bag light, displaying "AIR BAG" in the instrument panel, monitors the circuits of the supplemental air bag. The circuits monitored by the supplemental air bag light are the diagnosis sensor unit, supplemental air bag modules and all related wiring.

When the ignition key is in the "ON" or "START" position, the supplemental air bag light will illuminate for about 7 seconds and

PRE-DRIVING CHECKS AND ADJUSTMENTS

then turn off. This means the system is operational.

If any of the following conditions occur, the supplemental air bag system needs servicing:

1. The supplemental air bag light goes off within 7 seconds.
2. The supplemental air bag light flashes intermittently or remains on (after 7 seconds).
3. The supplemental air bag light does not come on at all.

Under these conditions, the Supplemental Restraint System Air Bag may not operate properly. It must be checked and repaired. Take your vehicle to the nearest authorized INFINITI dealer.



WARNING

If the supplemental air bag warning light is on, it could mean that the supplemental air bag will not operate in an accident.

Repair and replacement procedure

The supplemental air bag system is designed to inflate on a one-time-only basis. As a reminder, unless it is damaged, the supplemental air bag light will remain illuminated after inflation has occurred. Repair and replacement of the supplemental air bag system should be done only by authorized INFINITI dealers.

After a supplemental air bag inflates, the front instrument panel assembly should be replaced by your INFINITI dealer.

To ensure long-term functioning, the system must be inspected 10 years after the date of manufacture noted on the certification label located on the driver side center pillar.

When maintenance work is required on the vehicle, the supplemental air bag system and related parts should be pointed out to the person conducting the maintenance. The ignition key should always be in the "LOCK" position when working under the hood or inside the vehicle.



WARNING

- ***Once the supplemental air bag has inflated, the supplemental air bag module will not function again and must be replaced. The supplemental air bag module cannot be repaired.***

PRE-DRIVING CHECKS AND ADJUSTMENTS

- *The supplemental air bag system should be inspected by an authorized INFINITI dealer if there is any damage to the front end portion of the vehicle or replaced if the supplemental air bag has inflated.*
- *If you need to dispose of the supplemental air bag or scrap the vehicle, contact an authorized INFINITI dealer.*

Correct supplemental air bag disposal procedures are set forth in the appropriate INFINITI Service Manual. Incorrect disposal procedures could cause personal injury.

SEAT BELTS

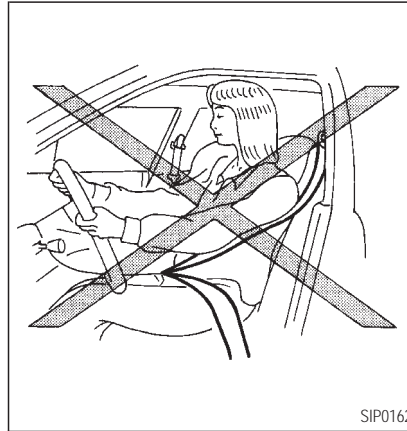

PRE-DRIVING CHECKS AND ADJUSTMENTS

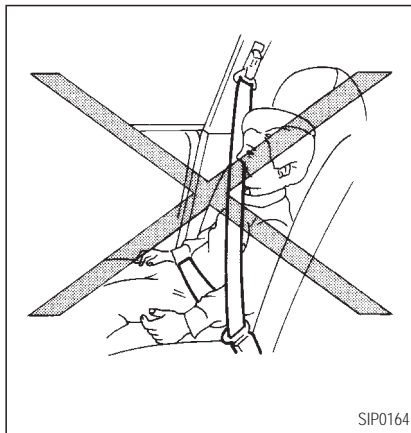

PRECAUTIONS ON SEAT BELT USAGE

Your chances of being injured in an accident and/or the severity of injury or killed may be greatly reduced if you are wearing your seat belt and it is properly adjusted. INFINITI strongly encourages you and all of your

passengers to buckle up every time you drive, even if your seating position includes a supplemental air bag.

Some states, provinces or territories require that seat belts be worn at all times when a vehicle is being driven.



WARNING

- *Every person who drives or rides in this vehicle should wear a seat belt at all times. Children should be properly restrained and, if appropriate, in a child restraint.*
- *The belt should be adjusted properly and to a snug fit. Failure to do so will reduce the effectiveness of the entire restraint system and increase the chance or severity of injury in an accident. Seri-*

ous injury or death can occur if the seat belt is not worn properly.

- *Always route the shoulder belt over your shoulder and across your chest. Never run the belt behind your back, under your arm or across your neck. The belt should be away from your face and neck, but not falling off your shoulder.*
- *Position the lap belt as low and snug as possible AROUND THE HIPS, NOT THE WAIST. A lap belt worn too high could increase the risk of internal injuries in an accident.*
- *Be sure the seat belt tongue is securely fastened to the proper buckle.*

PRE-DRIVING CHECKS AND ADJUSTMENTS

- *Do not wear the belt inside out or twisted. Doing so may reduce its effectiveness.*
- *Do not allow more than one person to use the same belt.*
- *Never carry more people in the vehicle than there are seat belts.*
- *If the seat belt warning lamp glows continuously while the ignition is turned "ON" with all doors closed and all seat belts fastened, it may indicate a malfunction in the system. Have the system checked by your INFINITI dealer.*
- *All seat belt assemblies including retractors and attaching hardware should be inspected after any collision by your INFINITI dealer.*

INFINITI recommends that all seat belt assemblies in use during a collision be replaced unless the collision was minor and the belts show no damage and continue to operate properly. Seat belt assemblies not in use during a collision should also be inspected and replaced if either damage or improper operation is noted.

- *Once the pre-tensioner has activated, it cannot be reused and must be replaced together with the retractor. See your INFINITI dealer.*

Child safety

Children need adults to help protect them.



WARNING

Infants and children need special protection. The vehicle's seat belts may not fit them properly. The shoulder belt may come too close to the face or neck. The lap belt may not fit over their small hip bones. In an accident, an improperly fitting seat belt could cause serious or fatal injury. Always use appropriate child restraints.

All U.S. states and provinces of Canada require the use of approved child restraints for infants and small children. (See "Child restraints for infants and small children" later in this section.)

In addition, there are many types of child restraints available for larger children which

PRE-DRIVING CHECKS AND ADJUSTMENTS

should be used for maximum protection.

Infant or small child:

INFINITI recommends that infants or small children be placed in child restraints that comply with Federal Motor Vehicle Safety Standards or Canadian Motor Vehicle Safety Standards. You should choose a child restraint which fits your vehicle and always follow the manufacturer's instructions for installation and use.

Children:

Children who are too large for child restraints should be seated and restrained by the seat belts which are provided.

INFINITI recommends that children sit in the rear seat if available. According to accident statistics, children are safer when properly restrained in the rear seat than in the front seat.

If the child's seating position has a shoulder

belt that fits close to the face or neck, the use of a booster seat (commercially available) may help overcome this. The booster seat should raise the child so that the shoulder belt is properly positioned across the top, middle portion of the shoulder and the lap belt is low on the hips. The booster seat should fit the vehicle seat and have a label certifying that it complies with Federal Motor Vehicle Safety Standards or Canadian Motor Vehicle Safety Standards. Once the child has grown so the shoulder belt is no longer on or near the face and neck, use the shoulder belt without the booster seat.



WARNING

Never let a child stand or kneel on any seat and do not allow a child in the cargo areas while the vehicle is moving. The child could be seriously

injured or killed in an accident.

Pregnant women

INFINITI recommends that pregnant women use seat belts. Contact your doctor for specific recommendations. The lap belt should be worn snug and positioned as low as possible around the hips, not the waist.

Injured persons

INFINITI recommends that injured persons use seat belts, depending on the injury. Check with your doctor for specific recommendations.

PRE-DRIVING CHECKS AND ADJUSTMENTS

3-POINT TYPE WITH RETRAC-TOR



WARNING

Every person who drives or rides in this vehicle should wear a seat belt at all times.

Fastening the belts

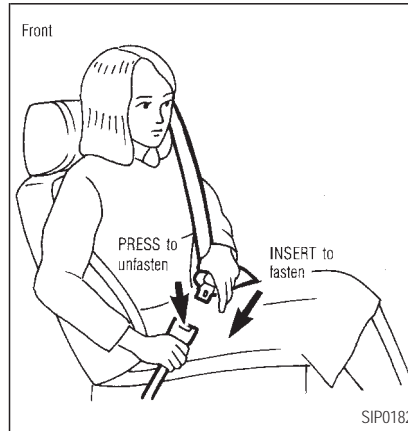

1. Adjust the seat.



WARNING

Do not ride in a moving vehicle when

the seatback is reclined. This can be dangerous. The shoulder belt will not be against your body. In an accident you could be thrown into it and receive neck or other serious injuries. You could also slide under the lap belt and receive serious internal injuries.

For most effective protection when the vehicle is in motion, the seat should be upright. Always sit well back in the seat and adjust the seat belt properly.

2. Slowly pull the seat belt out of the retractor and insert the tongue into the buckle until it snaps.

PRE-DRIVING CHECKS AND ADJUSTMENTS

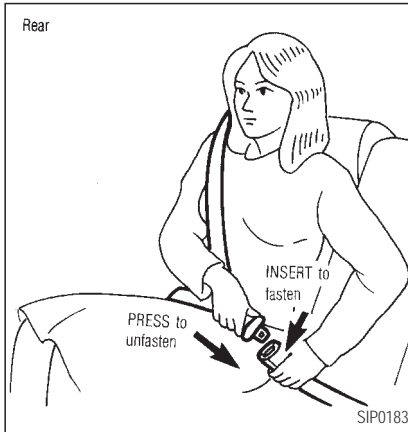

The retractor is designed to lock during a sudden stop or on impact. A slow pulling motion will permit the belt to move, and allow you some freedom of movement in the seat.

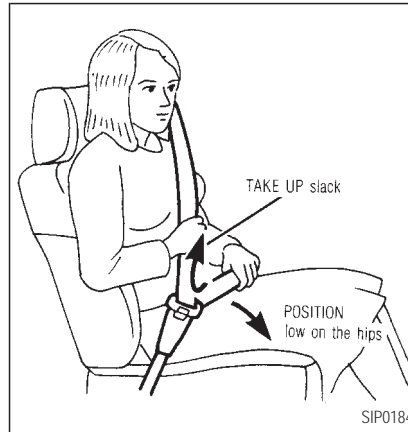

3. Position the lap belt portion **low and snug on the hips** as shown.
4. Pull the shoulder belt portion toward the retractor to take up extra slack.

The front passenger side seat belt and rear 3-point seat belts have a cinching mechanism for child seat installation. It is referred to as

the automatic locking mode. When the cinching mechanism is activated the seat belt cannot be withdrawn again until the seat belt tongue is detached from the buckle and fully retracted. Refer to "Child Restraint Systems for Infants and Small Children" later in this section for more information.

The automatic locking mode should be used only for child seat installation. During normal seat belt use by a passenger, the locking mode should not be activated. If it is activated it may cause uncomfortable seat belt tension.

Unfastening the belts

To unfasten the belt, press the button on the buckle. The seat belt will automatically retract.

Checking seat belt operation (3-point type with retractor)

Your seat belt retractors are designed to lock belt movement by two separate methods:

PRE-DRIVING CHECKS AND ADJUSTMENTS

1) When the belt is pulled quickly from the retractor.

2) When the vehicle slows down rapidly.

You can check their operation as follows:

- Grasp the shoulder belt and pull quickly forward. The retractor should lock and restrict further belt movement.

If the retractor does not lock during this check or if you have any question about belt operation, see your INFINITI dealer.

Shoulder belt height adjustment (For front seats)

The shoulder belt anchor height should be adjusted to the position best for you. (See "Precautions on seat belt usage".)

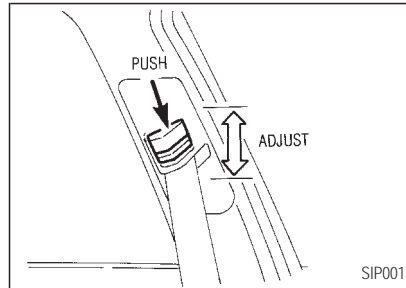

To adjust, push the release button, and then move it to the desired position, so that the belt passes over the center of the shoulder. The belt should be away from your face and neck, but not falling off of your shoulder.



WARNING

- ***After adjustment, release the button and check that it does not move up and down to make sure the shoulder belt anchor is se-***

curely fixed in position.

2-POINT TYPE WITHOUT RETRACTOR (Rear center lap belt)

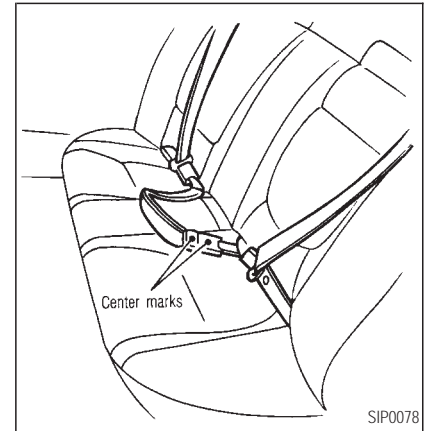

PRE-DRIVING CHECKS AND ADJUSTMENTS

Selecting correct set of belts

The center seat belt buckle and tongue are identified by the "CENTER" mark. The center seat belt tongue can be fastened **only** into the center seat belt buckle.

Fastening the belts

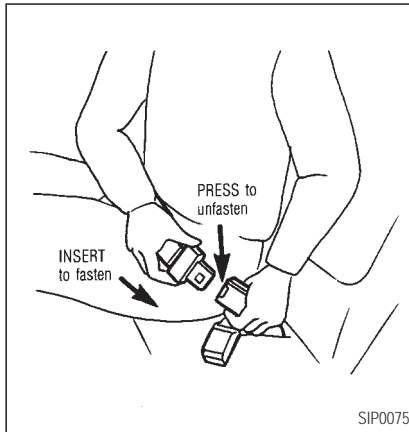

1. Insert the tongue into the buckle marked

CENTER until it snaps.

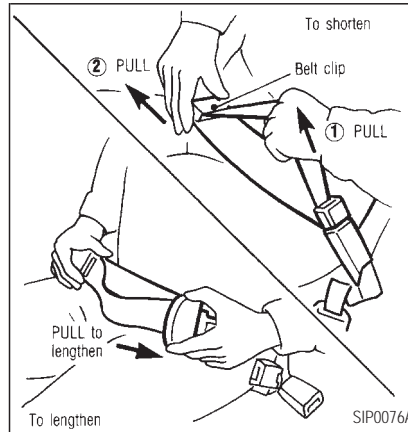

2. To lengthen, hold the tongue at a right angle to the belt and pull on the belt.

To shorten, pull the free end of the belt away from the tongue, then pull the belt clip to take up the slack.

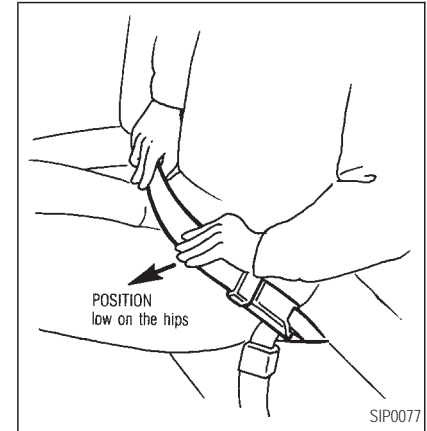

3. Position the lap belt **low and snug on the hips** as illustrated.

Unfastening the belts

To unfasten the belt, press the button on the buckle.

PRE-DRIVING CHECKS AND ADJUSTMENTS

SEAT BELT EXTENDERS

If, because of body size or driving position, it is not possible to properly fit the lap-shoulder belt and fasten it, an extender is available which is compatible with the installed seat belts. The extender adds approximately 8 inches (200 mm) of length and may be used for either the driver or front passenger seating position. See your INFINITI dealer for assistance if the extender is required.



WARNING

- **Only INFINITI belt extenders, made by the same company which made the original equipment belts, should be used with the INFINITI belts.**

- ***Persons who can use the standard seat belt should not use an extender. Such unnecessary use could result in serious personal injury in the event of an accident.***

SEAT BELT MAINTENANCE

- **To clean the belt webbings**, apply a mild soap solution or any non-caustic solution recommended for gently cleaning cloth upholstery or carpets. Then brush it, wipe with a cloth and allow it to dry in the shade. Do not allow the belts to retract until they are completely dry.
- **Periodically check to see that the belt and the metal components** such as buckles, tongues, retractors, flexible wires and anchors work properly. If loose parts, deterioration, cuts or other damage on the webbing are found, the entire belt

assembly should be replaced.

CHILD RESTRAINTS FOR INFANTS AND SMALL CHILDREN



WARNING

- ***Infants and small children should always be placed in an appropriate child restraint while riding in the vehicle. Failure to use a child restraint can result in serious injury or death.***
- ***Children and infants should never be carried on your lap. It is not possible for even the strongest adult to resist the forces of a severe accident. The child could be crushed between the adult and***

PRE-DRIVING CHECKS AND ADJUSTMENTS

parts of the vehicle. Also, do not put the same seat belt around both your child and yourself.

- *INFINITI recommends that the child restraint be installed in the rear seat. According to accident statistics, children are safer when properly restrained in the rear seat than in the front seat.*
- *An improperly installed child restraint could lead to serious injury or death in an accident.*

In general, child restraints are designed to be installed with a lap belt or the lap portion of a three-point type seat belt.

Child restraints specially designed for infants and small children are offered by several manufacturers. When selecting any child re-

straint system, keep the following points in mind:

- 1) Choose only a restraint with a label certifying that it complies with Federal Motor Vehicle Safety Standard 213 or Canadian Motor Vehicle Safety Standard 213.
- 2) Check that child restraint in your vehicle to be sure it is compatible with the vehicle's seat and seat belt system. Choose a child restraint that meets the guidelines of Society of Automotive Engineers recommended practice J1819 for child restraint installation.
- 3) If the child restraint is compatible with your vehicle, place your child in the child restraint and check the various adjustments to be sure the child restraint is compatible with your child. Always follow all recommended procedures.

All U.S. states and provinces of Canada require that infants and small children

be restrained in approved child restraint systems at all times while the vehicle is being operated.



WARNING

- *Never install a rear-facing child restraint in the front seat. An inflating supplemental air bag could seriously injure or kill your child. A rear-facing child restraint must only be used in the rear seat. See "Installation on front passenger seat" for details.*
- *Improper use of a child restraint can result in increased injuries for both the infant or child and other occupants in the vehicle.*
- *Follow all of the child restraint manufacturer's instructions for*

PRE-DRIVING CHECKS AND ADJUSTMENTS

installation and use. When purchasing a child restraint, be sure to select one which will fit your child and vehicle. It may not be possible to properly install some types of child restraints in your vehicle.

- *If the child restraint is not anchored properly, the risk of a child being injured in a collision or a sudden stop greatly increases.*
- *Adjustable seatbacks should be positioned to fit the child restraint, but as upright as possible.*
- *After attaching the child restraint, test the restraint before you place the child in it. Tilt the restraint*

from side to side. Try to tug it forward and check to see if the belt holds it in place. If the restraint is not secure, tighten the belt as necessary, or put the restraint in another seat and test it again.

- *For a front facing child restraint, if the seat position where it is installed has a 3-point type lap/shoulder belt, check to make sure the shoulder belt does not go in front of the child's face or neck. If it does, put the shoulder belt behind the child restraint.*
- *When your child restraint is not in use, store it in the trunk or keep it secured with a seat belt to prevent it from being thrown around*

in case of a sudden stop or accident.



CAUTION

Remember that a child restraint left in a closed vehicle can become very hot. Check the seating surface and buckles before placing your child in the child restraint.

PRE-DRIVING CHECKS AND ADJUSTMENTS

Installation on rear seat

Center lap belt

When you install a child restraint in a rear center seat, follow these steps:

1. Position the child restraint on the seat as illustrated. It can be placed in a forward facing or rear facing direction, depending on the size of the child. Always follow the restraint manufacturer's instructions.
2. Route the seat belt tongue through the child restraint and insert it into the buckle until you hear and feel the latch engage. Be sure to follow the child restraint manufacturer's instructions for belt routing.
3. Remove all slack in the lap belt for a very tight fit by pulling forcefully on the lap belt adjustment.
4. Before placing the child in the child restraint, use force to tilt the child restraint from side to side, and tug it forward to

make sure that it is securely held in place.

5. If it is not secure, try to tighten the belt again, or put the restraint in another seat.
6. Check to make sure the child restraint is properly secured prior to each use.

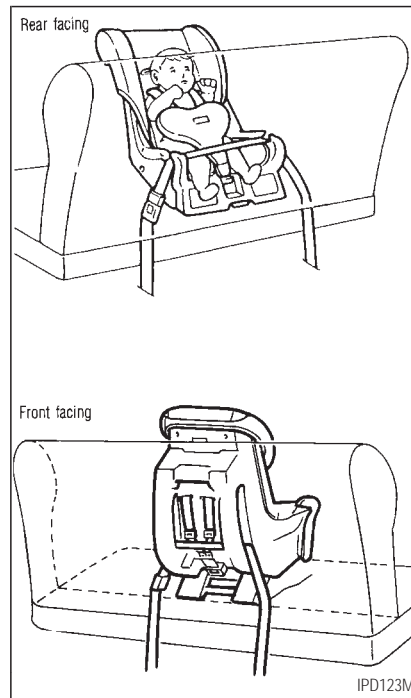

PRE-DRIVING CHECKS AND ADJUSTMENTS

Outboard shoulder/lap belt

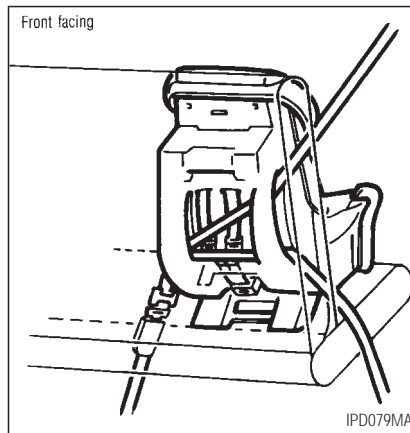
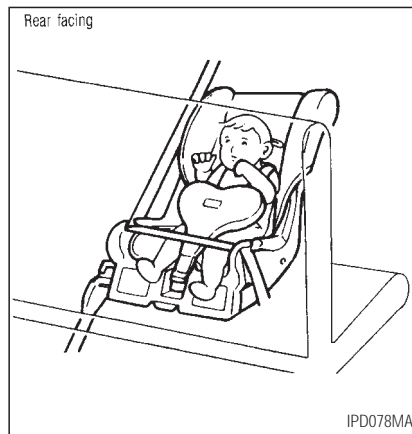

Installation on rear outboard seating positions

WARNING

- *The 3-point belt on your vehicle is equipped with a locking mode*

retractor which must be used when installing a child restraint.

- *Failure to do so will result in the child restraint not being properly secured. It could tip over or otherwise be unsecured and cause injury to the child in a sudden stop or collision.*

When you install a child restraint in a rear outboard seat, follow these steps:

1. Position the child restraint on the seat as illustrated. It can be placed in a forward facing or rear facing direction, depending on the size of the child. Always follow the restraint manufacturer's instructions.
2. Route the seat belt tongue through the child restraint and insert it into the buckle until you hear and feel the latch engage.

PRE-DRIVING CHECKS AND ADJUSTMENTS

Be sure to follow the child restraint manufacturer's instructions for belt routing.

3. Pull on the shoulder belt until all of the belt is fully extended and a click is heard. At this time, the belt retractor is in the automatic locking mode (child restraint mode). It will revert back to "emergency locking" when the belt is fully retracted.
4. Allow the belt to retract. A clicking sound will be heard as the belt retracts. This indicates that the retractor is in the automatic locking mode. Pull up on the belt to remove any slack in the belt.
5. Before placing the child in the child restraint, use force to tilt the child restraint from side to side, and tug it forward to make sure that it is securely held in place.
6. Check that the retractor is in the automatic locking mode by trying to pull more belt out of the retractor. If you cannot pull any more belt webbing out of the retractor, the

belt is in the automatic locking mode.

7. Check to make sure that the child restraint is properly secured prior to each use. If the lap belt is not locked, repeat steps 3 through 6.

After the child restraint is removed and the seat belt is allowed to wind back into the retractor, the automatic locking mode (child restraint mode) is canceled; the seat belt may be used as normal and will only lock during a sudden stop or impact.

Top strap child restraint

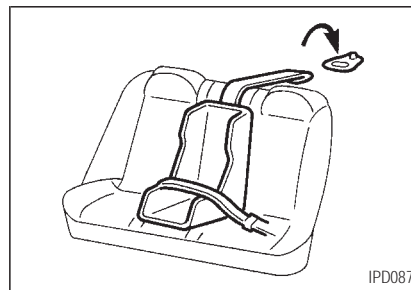

If your child restraint has a top strap, install the anchor bracket to the provided anchor point. Anchor bracket hardware must be installed. The top strap anchor bracket hardware is available through your INFINITI dealer.

Part #88894-89900

Secure the child restraint with the center lap belt or the lap portion of an outboard 3-point belt and latch the top strap hook onto the appropriate anchor bracket. To install the anchor bracket, a metric bolt of the dimen-

PRE-DRIVING CHECKS AND ADJUSTMENTS

sions listed below must be used.

Bolt diameter: 8.0 mm

Bolt length: more than 1.18 in (30 mm)

Thread pitch: 1.25 mm

The top strap should be secured to the attaching bolt which provides the straightest installation of the top strap.



WARNING

Child restraint anchor points are designed to withstand only those loads imposed by correctly fitted child restraints. Under no circumstances are they to be used for adult seat belts or harnesses.

Anchor point locations

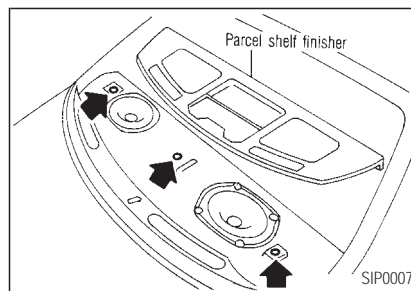

Anchor points are located under the rear parcel shelf finisher.

When installing a top strap child restraint on the rear seat for the first time, consult your INFINITI dealer for details.

PRE-DRIVING CHECKS AND ADJUSTMENTS

Installation on front passenger seat

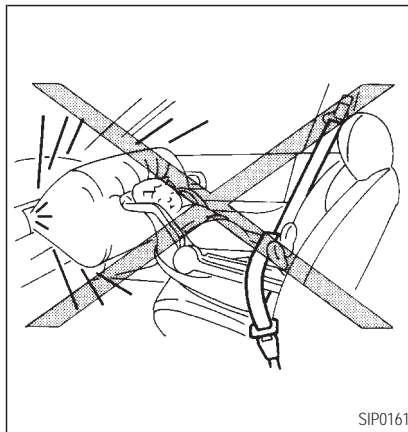
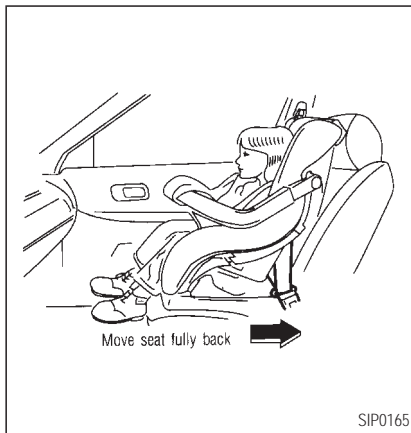

WARNING

- Never install a rear-facing child restraint in the front passenger seat. Supplemental air bags in-

flate with great force. A rear-facing child restraint could be struck by the supplemental air bag in a crash and could seriously injure or kill your child.

- If you install a forward-facing child restraint in the front-passenger seat, place the passenger seat as far back as possible.
- A child restraint with a top strap should not be used in the front passenger seat.
- The 3-point belt in your vehicle is equipped with a locking mode retractor which must be used when installing a child restraint.

PRE-DRIVING CHECKS AND ADJUSTMENTS

- **Failure to use the retractor's locking mode may result in the child restraint not being properly secured. The restraint could tip over or otherwise be unsecured and cause injury to the child in a sudden stop or collision.**

When you install a child restraint in the front seat, follow these steps:

1. Position the child restraint on the front passenger seat. **It should be placed in a forward facing direction only.** Move the seat as far back from the instrument panel as possible. Always follow the child restraint manufacturer's instructions. **Child restraints for infants must be used in the rear-facing direction and therefore must not be used in the front seat.**

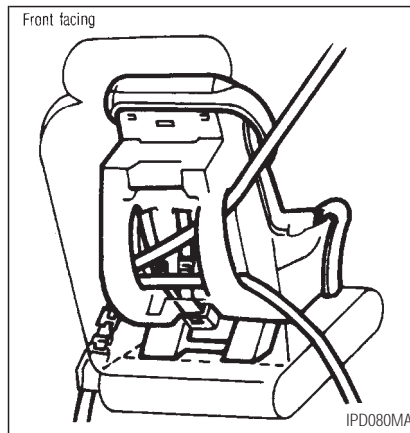

2. Route the seat belt tongue through the child restraint and insert it into the buckle until you hear and feel the latch engage.

Be sure to follow the child restraint manufacturer's instructions for belt routing.

3. Pull on the shoulder belt until all of the belt is fully extended and a click is heard.

At this time, the belt retractor is in the automatic locking mode (child restraint mode). (It will revert back to "emergency locking" when the belt is fully retracted.)

4. Allow the belt to retract. A clicking sound will be heard as the belt retracts. This indicates that the retractor is in the automatic locking mode. Pull up on the belt to remove any slack in the belt.
5. Before placing the child in the child restraint, use force to tilt the child restraint from side to side, and tug it forward to make sure that it is securely held in place.
6. Check that the retractor is in the automatic locking mode by trying to pull more belt out of the retractor. If you cannot pull any more belt webbing out of the retractor, the belt is in the automatic locking mode.
7. Check to make sure that the child restraint is properly secured prior to each use. If the lap belt is not locked, repeat steps 3 through 6.

PRE-DRIVING CHECKS AND ADJUSTMENTS

After the child restraint is removed and the seat belt is allowed to wind back into the retractor, the automatic locking mode (child restraint mode) is canceled; the seat belt may be used as normal and will only lock during a sudden stop or impact.

TILTING STEERING WHEEL

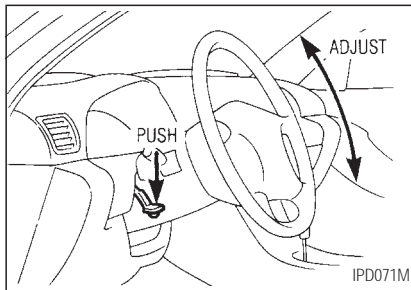

Tilt operation

Push the lock lever and while holding it down, adjust the steering wheel up or down to the desired position.

WARNING

Do not adjust the steering wheel while driving. You could lose control of your vehicle and cause an accident.

OUTSIDE MIRROR RE-MOTE CONTROL

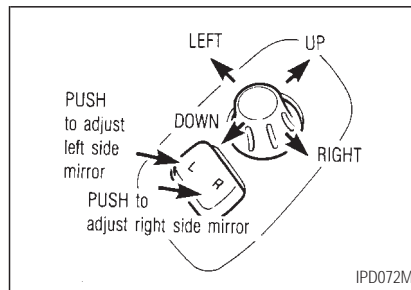

The outside mirror will operate only when the

ignition switch is in the "ACC" or "ON" position.

Push the right or left end of the switch to select the right or left side mirror, then adjust using the control lever.

WARNING

Objects viewed in the outside mirror on the passenger side are closer than they appear. Be careful when moving to the right. Using only this mirror could cause an accident. Use inside mirror or glance over your shoulder to properly judge distances to other objects.

PRE-DRIVING CHECKS AND ADJUSTMENTS

FOLDABLE OUTSIDE MIRRORS

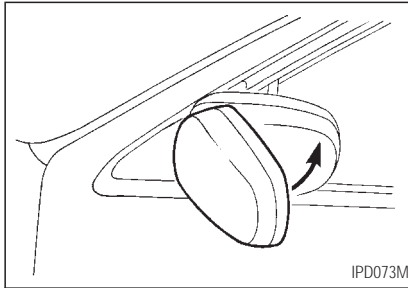

Push the outside mirror backward to fold it.

AUTOMATIC ANTI-DAZZLING INSIDE MIRROR

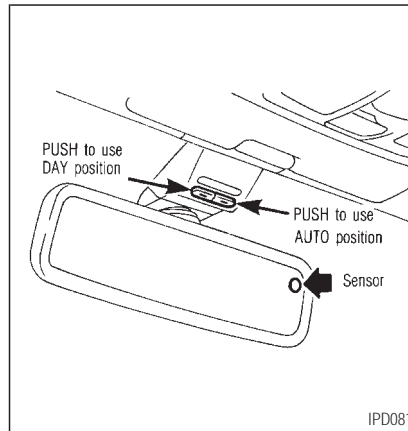

The inside mirror is designed so that it automatically changes reflection according to the intensity of the headlight of the following vehicle.

Push the DAY switch during daylight driving.

At night when the headlights of the following vehicle can cause excessive glare in the inside mirror, push the AUTO switch.

CENTER SUNVISOR

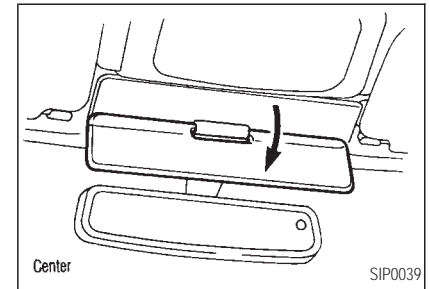

3 HEATER, AIR CONDITIONER AND AUDIO SYSTEM

Ventilator	3-2
Automatic air conditioner	3-3
Radio	3-7
CB radio or car phone	3-17

HEATER, AIR CONDITIONER AND AUDIO SYSTEM

VENTILATOR

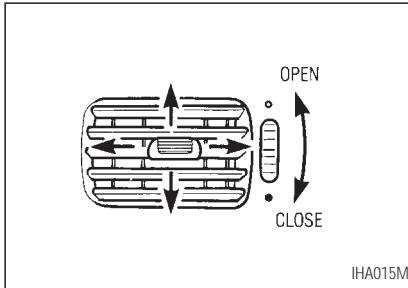

Open or close, and adjust the air flow direction of ventilators.

HEATER, AIR CONDITIONER AND AUDIO SYSTEM

AUTOMATIC AIR CONDITIONER

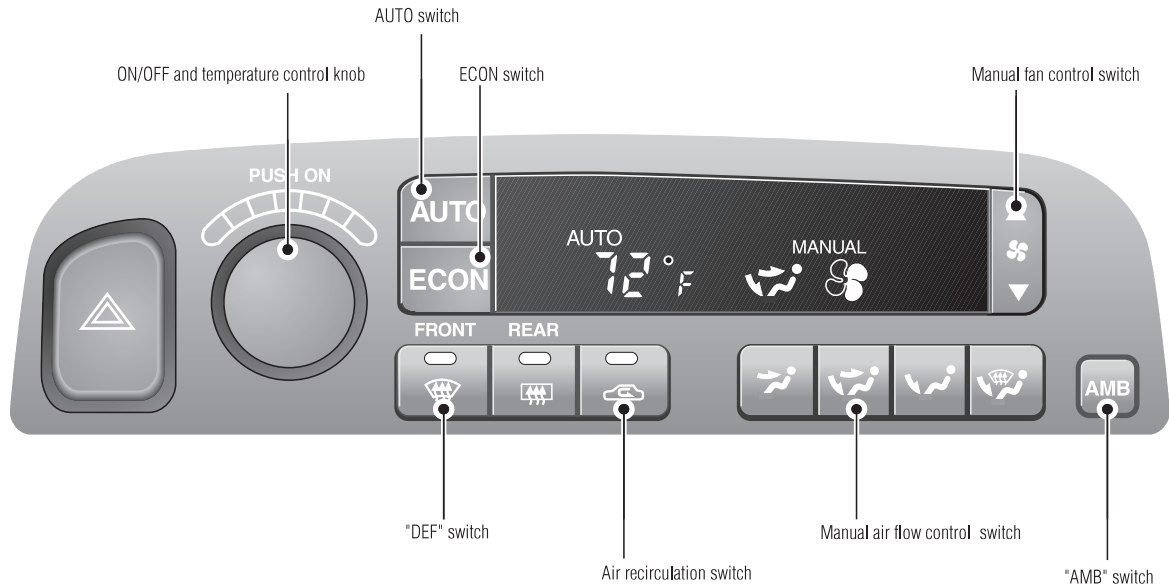

SIH0026

HEATER, AIR CONDITIONER AND AUDIO SYSTEM

Start the engine and operate the controls to activate the air conditioner.



WARNING

- *The air conditioner cooling function operates only when the engine is running.*
- *Do not leave children, unreliable adults, or pets alone in your vehicle. On hot, sunny days, temperatures in a closed vehicle could quickly become high enough to cause severe or possibly fatal injuries to people or animals.*
- *Do not use the recirculation mode for long periods as it may cause the interior air to become stale and the windows to fog up.*

- *Positioning of the heater and air conditioner controls should not be done while driving. In order that full attention may be given to the driving operation.*

Cooling and/or dehumidified heating (Auto mode)

This mode may be used all year round. The system works automatically to maintain a constant temperature. Air flow distribution and fan speed are also controlled automatically.

1. Push the AUTO switch on. ("AUTO" will appear on the display.)
 2. Turn the temperature set knob to set the desired temperature.
- For normal operation, adjust the temperature set knob to about 77°F (25°C).

Heating (ECON mode)



Use this mode when you need to heat only.

1. Push the ECON (ECONOMY) switch on. ("ECON" appears on the display.)
 2. Push the temperature set knob to set the desired temperature.
- The temperature of the passenger compartment will be maintained automatically. Air flow distribution and fan speed are also controlled automatically.
 - Do not set the temperature lower than the outside air temperature. Otherwise the system may not work properly.
 - If the windows fog up, do not use the ECON mode.

Dehumidified defogging

1. Push the "DEF  " switch on. (The indicator light on the switch will come on.) Air flows mainly from defroster outlets.

HEATER, AIR CONDITIONER AND AUDIO SYSTEM

2. Turn the temperature set knob to set the desired temperature.
- To remove ice or fog from the outside of the windows, push the manual fan control switch “” and set to the maximum position.
 - As soon as possible after the windshield is clean, push the AUTO switch to return to the auto mode.
 - When the “DEF ” switch is pushed, the air conditioner will automatically be turned on at outside temperatures above 32°F (0°C) to defog the windshield. The air recirculation mode will automatically be turned off.

Outside air is drawn into the passenger compartment to improve defogging performance.

Air recirculation switch

Push the air recirculation switch “” to

recirculate interior air inside the vehicle. The indicator light on the switch will come on.

Push it again to draw outside air into the passenger compartment. The indicator will go out.

- The air recirculation switch can not be activated when the air conditioner is in the DEF mode.

Manual operation

A resume function is provided. When the ON/OFF switch is turned off after setting manually to the desired operating conditions, turning the ON/OFF switch on will return the previously set conditions.

Manual fan speed control

Push the fan control switch “” to change the fan speed manually.

- Push the AUTO switch to return to automatic control of the fan speed.

Manual air flow control switch

Pushing the manual air flow control switch selects the air outlet to provide:

 : Air flow from center and side ventilators.

 : Air flow from center and side ventilators and foot outlets.

 : Air flow mainly from foot outlets.

 : Air flow from defroster and foot outlets.

To turn the system off

Push the ON/OFF switch.

Ambient temperature switch “AMB”

Push the ambient temperature switch. The outside ambient temperature will be displayed for approximately five seconds.

HEATER, AIR CONDITIONER AND AUDIO SYSTEM

Operating tips

- When the engine coolant temperature and outside air temperature are low, the air flow from the foot outlets may not operate for 20 to 150 seconds. This is not a malfunction. After the coolant temperature warms up, air flow from the foot outlets will operate normally.

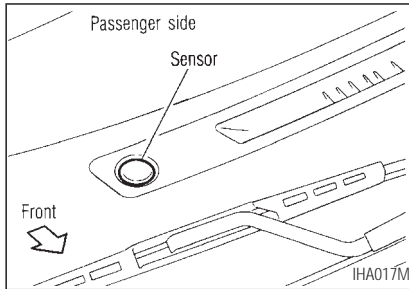

The sensor on the instrument panel helps maintain a constant temperature. Do not put anything on or around this sensor.

Servicing air conditioner

The air conditioning system in your INFINITI is charged with a refrigerant designed with the environment in mind. **This refrigerant will not harm the earth's ozone layer.** However, special charging equipment and lubricant are required when servicing your INFINITI air conditioner. Using improper refrigerants or lubricants will cause severe damage to your air conditioning system. See "Air conditioning system refrigerant and lubricant recommendations" in the "Technical and consumer information" section of this manual.

Your INFINITI dealer will be able to service your environmentally "friendly" air conditioning system.

HEATER, AIR CONDITIONER AND AUDIO SYSTEM

RADIO

Turn the ignition key to "ACC" or "ON" and press the power on switch to turn on the radio. If you listen to the radio with the engine not running, the key should be turned to the "ACC" position.

Radio reception is affected by station signal strength, distance from radio transmitter, buildings, bridges, mountains and other external influences. Intermittent changes in reception quality normally are caused by these external influences.

RADIO RECEPTION

Your INFINITI radio system is equipped with state-of-the-art electronic circuits to enhance radio reception. These circuits are designed to extend reception range, and to enhance the quality of that reception.

However there are some general characteristics of both FM and AM radio signals that can

affect radio reception quality in a moving vehicle, even when the finest equipment is used. These characteristics are completely normal in a given reception area, and do not indicate any malfunction in your INFINITI radio system.

Remember that a moving vehicle is not the ideal place to listen to a radio. Because of the movement, reception conditions will constantly change. Buildings, terrain, signal distance and interference from other vehicles can work against ideal reception. Described below are some of the factors that can affect your radio reception.

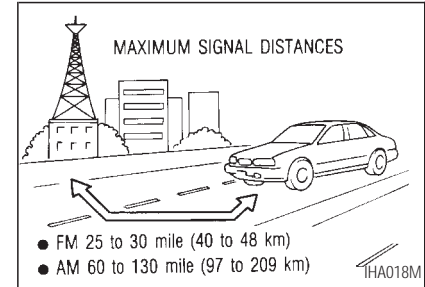

FM RADIO RECEPTION

Range: FM range is normally limited to 25 to 30 miles (40 to 48 km), with monaural (single channel) FM having slightly more range than stereo FM. External influences may sometimes interfere with FM station reception even if the FM station is within 25 miles (40 km). The strength of the FM signal is directly related to the distance between the transmitter and receiver. FM signals follow a line-of-sight path, exhibiting many of the same character-

HEATER, AIR CONDITIONER AND AUDIO SYSTEM

istics as light. For example they will reflect off objects.

Fade and drift: As your vehicle moves away from a station transmitter, the signals will tend to fade and/or drift.

Static and flutter: During signal interference from buildings, large hills or due to antenna position, usually in conjunction with increased distance from the station transmitter, static or flutter can be heard. This can be reduced by adjusting the TREBLE control counterclockwise to reduce treble response.

Multipath reception: Because of the reflective characteristics of FM signals, direct and reflected signals reach the receiver at the same time. The signals may cancel each other, resulting in momentary flutter or loss of sound.

AM RADIO RECEPTION

AM signals, because of their low frequency, can “bend” around objects and skip along the

ground. In addition, the signals can be bounced off the ionosphere and bent back to earth. Because of these characteristics. AM signals are also subject to interference as they travel from transmitter to receiver.

Fading: Occurs while the vehicle is passing through freeway underpasses or in areas with many tall buildings. It can also occur for several seconds during ionospheric turbulence even in areas where no obstacles exist.

Static: Caused by thunderstorms, electrical power lines, electric signs and even traffic lights.

HEATER, AIR CONDITIONER AND AUDIO SYSTEM

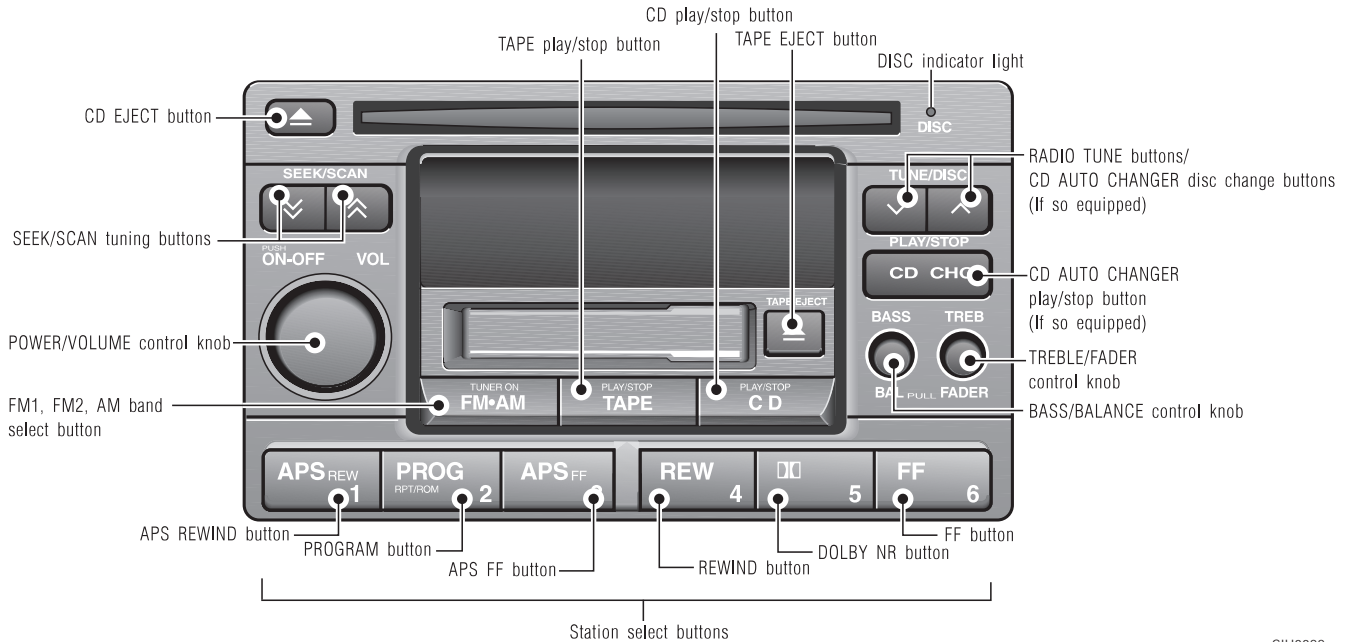

SIH0028

HEATER, AIR CONDITIONER AND AUDIO SYSTEM

AUDIO MAIN OPERATION

Head unit

The radio has an FM Diversity reception system, which employs two antennas. One is a rod type antenna; the other is an antenna printed on the window. This system automatically switches to the antenna which is receiving less noise.

The tape deck employs a permalloy head which allows for improved reproduction of high frequency ranges. Noise is also greatly reduced by the combined use of the Dolby NR (noise reduction) system. The auto loudness circuit enhances the low frequency range automatically in both radio reception and tape and CD playback.

Power/Volume control

Turn the ignition key to "ACC" or "ON", and then push the POWER/VOLUME knob while the system is off to call up the mode (radio, tape or CD) which was playing immediately

before the system was turned off. When no CD or tape is loaded, the radio will come on. While the system is on, pushing the POWER/VOLUME knob turns the system off.

To turn the radio off, press the POWER/VOLUME knob.

Turn the POWER/VOLUME control knob to adjust the volume.

Adjusting tone quality

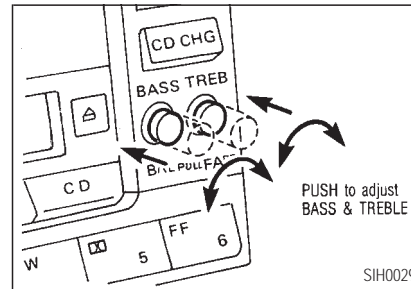

Push then turn the BASS and TREB (TREBLE)

control knobs to obtain the most pleasant sound.

Adjusting speaker sound balance

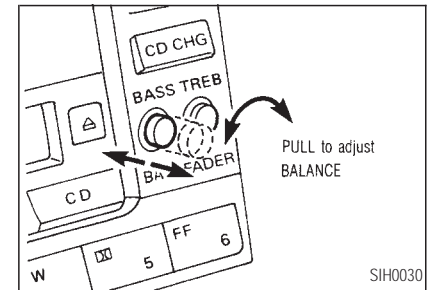

Push then pull the BAL (BALANCE) control knob to adjust the volume between the right and left speakers.

Fader volume control

Push then pull the FADER control knob to adjust the volume between the front and rear speakers.

HEATER, AIR CONDITIONER AND AUDIO SYSTEM

RADIO OPERATION

FM•AM band select button



Pushing the FM•AM band select button will change the band.

When FM•AM band select button is pushed while the ignition switch is at "ACC" or "ON", the radio will come on at the station last played.

The last station played will also come on when the power knob is turned to ON.

If a compact disc or tape is inserted when the power knob is turned to ON, the compact disc or tape will automatically be turned off and the last radio station played will come on.

The FM stereo indicator "ST" will glow during FM stereo reception. When the stereo broadcast signal is weak, the radio will automatically change from stereo to monaural reception.

TUNE button  



WARNING

The radio should not be tuned while driving in order that full attention may be given to the driving operation.

Use these buttons for manual tuning.

If the TUNE button is pushed for less than 0.5 seconds, the frequency moves by an increment of 1 step.

To move quickly through the channels, hold either of the TUNE buttons down for more than 0.5 seconds.

SEEK/SCAN tuning buttons



SEEK tuning

Push the SEEK/SCAN tuning button " ≡ " or " ≡ " for less than 1.5 seconds. SEEK tuning begins from low to high frequencies and stops at the next broadcasting station.

SCAN tuning

Push the SEEK/SCAN tuning button " ≡ " or " ≡ " for more than 1.5 seconds. SCAN tuning begins from low to high frequencies and stops at each broadcasting station for five seconds. Pushing the button again during this five seconds period will stop SCAN tuning and the radio will remain tuned to that station.

If the SEEK/SCAN tuning button is not pushed within five seconds, SCAN tuning moves to the next station.

HEATER, AIR CONDITIONER AND AUDIO SYSTEM

Station memory operations

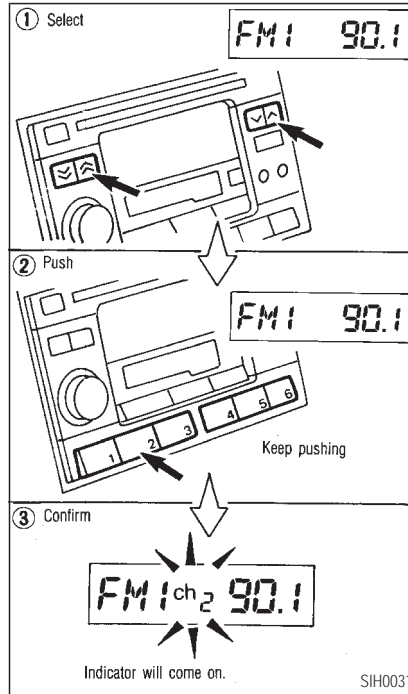

Twelve stations can be set for the FM band.

Six stations can be set for the AM band.

1. Tune to the desired station using the SEEK/SCAN or TUNE button.
2. Push the desired station select button for more than 1.5 seconds. (For example, in the diagram ch2 is to be memorized. The radio ceases emitting sounds when the select button is pushed.)
3. The indicator "ch2" will then come on and the sound will resume. Memorizing is now complete.
4. Other buttons can be set in the same manner.

If the battery cable is disconnected, or if the fuse blows, the radio memory will be cancelled. In that case, reset the desired stations.

HEATER, AIR CONDITIONER AND AUDIO SYSTEM

CASSETTE TAPE PLAYER OPERATION

Turn the ignition key to "ACC" or "ON", and then lightly insert the cassette tape into the tape door. The cassette tape will be automatically pulled into the player.

The radio or CD will turn off (if it is on) and the cassette tape will begin to play.



CAUTION

Do not force the cassette tape into the tape door.

This could cause player damage.





If the system is turned off by pushing the POWER/VOLUME knob with the cassette tape still in the player, the tape will resume playing when the system is turned back on.

TAPE button

- When this button is pushed with the system turned off and a tape loaded, the system will come on and the tape will play.
- When this button is pushed with either the radio or compact disc turned on and the tape loaded, the compact disc or the radio will automatically be turned off and the tape will play.

While the tape is playing, pushing the TAPE button stops the tape. Pushing the button again allows the tape to play.



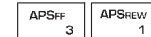

FF (fast forward), REW (rewind) button

Push the FF (fast forward) button to fast forward the tape. To rewind the tape, push the REW (rewind) button. Either the indicator light  ,  ,  or  will come on when the FF or REW function is started.

APS (automatic program search) FF, APS REW button



When the APS FF button is pushed while the tape is being played, the next program will start to play from the beginning. Push the APS FF button several times to skip through programs. The tape will advance the number of times the button is pushed (up to 9 programs).

When the APS REW button is pushed once, the program being played starts over from the beginning. Push several times to fast rewind programs. The tape will go back the number of times the button is pushed. Either the indicator light  ,  ,  or  will come on when the APS FF or APS REW function is started.

This system searches for the blank intervals between selections. If there is a blank interval within one program or there is no interval

HEATER, AIR CONDITIONER AND AUDIO SYSTEM

between programs, the system may not stop in the desired or expected location.

PROG (program) button





Push the PROG (program) button to change the tape side while the tape is being played.

The cassette tape will automatically change directions to play the other side when the first side is completed.

Dolby NR (noise reduction) button



Push the  "DOLBY NR" button for Dolby NR encoded tapes to reduce high frequency tape noise. The indicator will come on.

Dolby noise reduction manufactured under license from Dolby Laboratories Licensing Corporation. "DOLBY" and the double-D symbol  are trademarks of Dolby Laboratories Licensing Corporation.

Metal or chrome tape usage

The cassette player will be automatically set to high performance play when playing a metal or chrome cassette tape.

TAPE EJECT button



When this button is pushed with the tape loaded, the tape will be ejected.

When the tape is ejected while it is being played, the system will be turned off.

Precautions on cassette tape player operation

- To maintain good quality sound, INFINITI recommends that you use cassette tapes of 60 minutes or shorter in length.
- Cassette tapes should be removed from the player when not in use. Store cassettes in their protective cases and away from direct sunlight, heat, moisture or magnetic sources.

Direct sunlight can cause the cassette to become deformed. The use of deformed cassettes may cause the cassette to jam in the player.

- Do not use cassettes that have peeling or loose labels. If used, the label could jam in the player.
- If a cassette has loose tape, insert a pencil through one of the cassette hubs and rewind the tape firmly. Loose tape may cause jamming and wavering sound quality.
- Over a period of time, the playback head, capstan and pinch roller may gather a tape coating residue as the tape passes over the head. This residue accumulation can cause a weak or wavering sound and should be removed periodically with a head cleaning tape.

If the residue is not removed periodically, the player may need to be

HEATER, AIR CONDITIONER AND AUDIO SYSTEM

disassembled for cleaning.

COMPACT DISC (CD) PLAYER OPERATION

Turn the ignition key to the "ACC" or "ON" position and insert the compact disc into the slot with the label side facing up. The compact disc will be guided automatically into the slot and start playing.

After loading the disc, the number of tracks on the disc and the play time will appear on the display.

If the radio or tape is already operating, it will automatically turn off and the compact disc will play.



CAUTION

Do not force the compact disc into the slot. This could damage the player.

If the system has been turned off while the compact disc was playing, pushing the POWER/VOLUME knob will start the compact disc.

8 cm diameter compact discs can also be used without an adapter.

CD button



When this button is pushed with the system off and the compact disc loaded, the system will turn on and the compact disc will start to play.

When this button is pushed with the compact disc loaded but the tape or the radio playing, the tape or radio will automatically be turned off and the compact disc will start to play.

When this button is pushed while the compact disc is playing, the compact disc will stop playing. When this button is pushed with the compact disc stopped, the compact disc will start to play.

FF (fast forward), REW (rewind) button



When the FF (fast forward) or REW (rewind) button is pushed while the compact disc is being played, the compact disc will play while fast forwarding or rewinding. When the button is released, the compact disc will return to normal play speed.

APS (automatic program search) FF, APS REW button

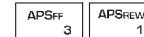

When the APS FF button is pushed while the compact disc is being played, the program next to the present one will start to play from its beginning. Push several times to skip through programs. The compact disc will advance the number of times the button is pushed. (When the last program on the compact disc is skipped through, the first program will be played.) When the APS REW button is pushed, the program being played

HEATER, AIR CONDITIONER AND AUDIO SYSTEM

returns to its beginning. Push several times to skip back through programs. The compact disc will go back the number of times the button is pushed.

PROG (program) button



When this button is pushed while the compact disc is being played, the play pattern will change as follows:

ALL: All the programs will be played repeatedly in sequence.

1: Only one program (the one being played when the PROG (program) button is pushed) will be repeated.

RANDOM: Programs will be played at random, not following the sequence on the compact disc. The same program may be repeated twice.

(no mark): All the programs will be played in sequence and stop when the last program is finished.

- **When the compact disc is ejected, the play pattern will automatically change to ALL.**

CD EJECT button



When the CD EJECT button is pushed with the compact disc loaded, the compact disc will be ejected.

When this button is pushed while the compact disc is being played, the compact disc will come out and the system will turn off.

If the compact disc comes out and is not removed, it will be pulled back into the slot to protect it.

DISC indicator light

This light comes on when the compact disc is loaded.



CAUTION

- ***During cold weather or rainy days, the player may malfunction due to the humidity. If this occurs, remove the CD and dehumidify or ventilate the player completely.***
- ***The player may skip while driving on rough roads.***
- ***The CD player sometimes cannot function when the compartment temperature is extremely high. Decrease the temperature before use.***
- ***Do not expose the CD to direct sunlight.***
- ***Do not use an 8 cm CD adapter as this will cause malfunction.***

HEATER, AIR CONDITIONER AND AUDIO SYSTEM

Power antenna

The antenna will automatically extend when the radio is turned on, and retract when switched off. If the radio is left on, the antenna will retract and extend with the ignition key "OFF-ON" operation.

CAUTION

- Before turning the radio on, make sure that no one is near the antenna outlet and there is enough space for it to extend.
- To prevent damage, be sure that antenna is fully retracted before the vehicle enters an automatic car wash.
- Dirt and other foreign matter on the power antenna rod may interrupt its operation. Clean the rod

periodically with a damp cloth. This type of cleaning is especially important during the winter seasons in areas where road salt and other chemicals may be spread on road surfaces and splashed onto the antenna rod.

CB RADIO OR CAR PHONE

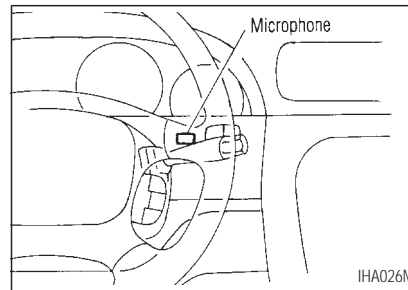

If equipped with a genuine cellular phone,

your INFINITI features a non-directional microphone, so it is not necessary to look at or speak directly into the microphone when calling.

To do so could detract from the driving operation and cause an accident.

See the manual for car phone operation.

All INFINITI J30 models are pre-wired to accept the genuine INFINITI cellular phone. In addition, the J30 model has the phone antenna built into the rear glass window.

When installing a CB radio or a car phone in your INFINITI, be sure to observe the following cautions, otherwise the new equipment may adversely affect the PCME system and other electronic parts.

CAUTION

- Keep the antenna as far as pos-

sible away from the Electronic Control Unit (including radio).

- *Keep the antenna wire more than 8 inches (20 cm) away from the PCME harness. Do not route the antenna wire next to any harness.*
- *Adjust the antenna standing-wave ratio as recommended by the manufacturer.*

Connect the ground wire from the CB radio chassis to the body.

- *For details, consult your INFINITI dealer.*

4 STARTING AND DRIVING

Precautions when starting and driving	4-2
Avoiding collision and rollover	4-4
Drinking alcohol/drugs and driving	4-4
Ignition switch	4-5
Before starting the engine	4-6
Driving with automatic transmission	4-6
Starting the engine	4-10
Parking brake	4-11
Cruise control	4-12
Break-in schedule	4-14
Economy hints	4-14
Parking/parking on hills	4-15
Power assisted system	4-16
Brake system	4-16
Anti-lock brake system	4-17
Cold weather driving	4-19

STARTING AND DRIVING

PRECAUTIONS WHEN STARTING AND DRIVING



WARNING

Do not leave children, unreliable adults, or pets alone in your vehicle. They could accidentally injure themselves or others through inadvertent operation of the vehicle. Also, on hot, sunny days, temperatures in a closed vehicle could quickly become high enough to cause severe or possibly fatal injuries to people or animals.



WARNING

EXHAUST GAS (Carbon Monoxide)

Do not breathe exhaust gases. They contain colorless and odorless carbon monoxide. Carbon monoxide is dangerous and can cause unconsciousness or death.

- *If you suspect that exhaust fumes are entering the vehicle, drive with all windows fully open, and have the vehicle inspected immediately.*
- *Do not run the engine in closed spaces such as a garage.*
- *Do not park the vehicle with the engine running for any extended length of time.*

- *Keep the trunk lid closed while driving, otherwise exhaust gases may be drawn into the passenger compartment. If you must drive with the rear lid open follow these precautions:*

1. *Open all the windows.*
2. *Set the air recirculate switch "OFF" and the fan control at "high" to circulate the air.*

- *If electrical wiring or other cable connections must be routed to a trailer through the seal on the trunk lid or the body, follow the manufacturer's recommendation to prevent carbon monoxide entry into the vehicle.*
- *The exhaust system and body should be inspected by a quali-*

STARTING AND DRIVING

fied technician whenever:

- a. *The vehicle is raised for service.*
- b. *You suspect that exhaust fumes are entering into the passenger compartment.*
- c. *You notice a change in the sound of the exhaust system.*
- d. *You have had an accident involving damage to the exhaust system, underbody, or rear of the vehicle.*

THREE WAY CATALYST

The three way catalyst is an emission control device installed in the exhaust system. Exhaust gases in the three way catalyst are burned at high temperatures to help reduce pollutants.



WARNING

- *The exhaust gas and the exhaust system are very hot. Keep people, animals or flammable materials away from the exhaust pipe.*
- *Do not stop or park the vehicle over flammable materials such as dry grass, waste paper or rags. They may ignite and cause a fire.*



CAUTION

- *Do not use leaded gasoline. Deposits from leaded gasoline will seriously reduce the three way catalyst ability to reduce exhaust pollutants.*

- *Keep your engine tuned up. Malfunctions in the ignition, fuel injection, or electrical systems can cause overrich fuel flow into the three way catalyst, causing it to overheat. Do not keep driving if the engine misfires, or if noticeable loss of performance or other unusual operating conditions are detected. Have the vehicle inspected promptly by an authorized INFINITI dealer.*
- *Avoid driving with an extremely low fuel level. Running out of fuel could cause the engine to misfire, damaging the three way catalyst.*
- *Do not race the engine while warming it up.*

STARTING AND DRIVING

- *Do not push or tow your vehicle to start the engine.*

AVOIDING COLLISION AND ROLLOVER



WARNING

Failure to operate this vehicle in a safe and prudent manner may result in loss of control or an accident.

Be alert and drive defensively at all times. Obey all traffic regulations. Avoid excessive speed, high speed cornering, or sudden steering maneuvers, because these driving practices could cause you to lose control of your vehicle. **As with any vehicle, a loss of control could result in a collision with other vehicles or objects, or cause the**

vehicle to rollover, particularly if the loss of control causes the vehicle to slide sideways. Be attentive at all times, and avoid driving when tired. Never drive when under the influence of alcohol or drugs (including prescription or over-the-counter drugs which may cause drowsiness). Always wear your seat belt as outlined in the "Seat Belts" section of this manual, and also instruct your passengers to do so.

DRINKING ALCOHOL/ DRUGS AND DRIVING



WARNING

Never drive under the influence of alcohol or drugs. Alcohol in the blood stream reduces coordination, delays reaction time and impairs judgement. Driving after drinking alcohol increases the likelihood of

being involved in an accident injuring yourself and others. Additionally, if you are injured in the accident alcohol can increase the severity of injury.

INFINITI is committed to safe driving. But, you must choose not to drive under the influence of alcohol. Every year thousands of people are injured or killed in alcohol related accidents. Although the local laws vary on what is considered to be legally intoxicated, the fact is that alcohol affects all people differently and most people underestimate the effects of alcohol.

Remember, drinking and driving do not mix!

And that's true for drugs too (over the counter, prescription, and illegal drugs). Do not drive if your ability to operate your vehicle is impaired

STARTING AND DRIVING

by alcohol, drugs, or some other physical condition.

IGNITION SWITCH

The switch includes an anti-theft steering lock device.

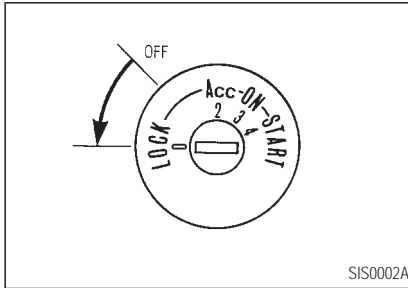

“LOCK” Normal parking position (0)

The ignition key can only be removed when the switch is in this position.

The ignition lock is designed so that the key cannot be turned to “LOCK” and removed until

the shift lever is moved to the “P” position.

When removing the key from the ignition, make sure the shift lever is in the “P” position.

If the shift lever is not returned to “P” (Park), the key cannot be moved toward LOCK.

When the key cannot be turned toward the “LOCK” position, proceed as follows to remove the key:

- 1) Move the shift lever into the “P” position.
- 2) Turn the ignition key slightly in the “ON” direction.
- 3) Turn the key toward the “LOCK” position.
- 4) Remove the key.

If the key is removed from the ignition switch, the shift lever cannot be moved from “P” (Park). **The shift lever can be moved if the ignition switch is in the “ACC” position. The shift lever can also be moved if the ignition switch is in the**

“ON” position and the foot brake pedal is depressed.

There is an “OFF” position in between “LOCK” and “ACC”, although it does not show on the lock cylinder. When the ignition is in “OFF” the steering wheel is not locked.

In order for the steering wheel to be locked, it must be turned about 1/6 of a turn counter-clockwise from the straight up position.

To lock the steering wheel, remove the key. To unlock the steering wheel, insert the key and turn it gently while rotating the steering wheel slightly right and left.



WARNING

*Never remove the key while driving.
If the key is removed, the steering*

wheel will lock. This may cause the driver to lose control of the vehicle and could result in serious vehicle damage or personal injury.

“OFF” (1)

The engine can be turned off without locking the steering wheel.

“ACC” (Accessories) (2)

This position activates electrical accessories such as the radio when the engine is not running. The automatic transmission selector lever can be shifted.

“ON” Normal operating position (3)

This position turns on the ignition system and the electrical accessories.

“START” (4)

STARTING AND DRIVING

This position activates the starter motor, starting the engine.

BEFORE STARTING THE ENGINE

- Make sure all windows and lights are clean.
- Visually inspect tires for condition. Also check tire pressure.
- Lock all doors.
- Position seat and adjust head restraints.
- Adjust inside and outside mirrors.
- Fasten seat belts and ask all passengers to do likewise.
- Check the operation of warning lights when key is turned to the “ON (3)” position.

DRIVING WITH AUTOMATIC TRANSMISSION

The automatic transmission in your vehicle is electronically controlled by a microcomputer to produce maximum power and smooth operation.

Recommended operating procedures for this transmission are shown on the following pages. Follow these procedures for maximum vehicle performance and driving enjoyment.

STARTING AND DRIVING

Starting the vehicle

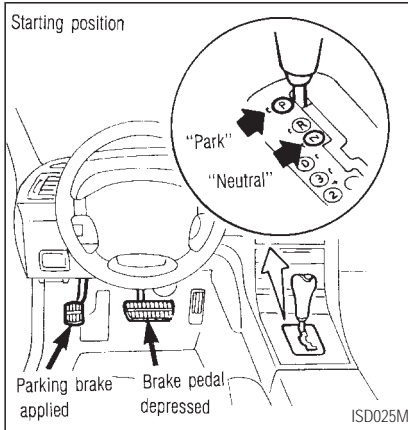

- After starting the engine, fully depress the foot brake pedal and push the selector lever button before shifting the selector lever from "P" to the "D", "R", "3", "2" or "1" position. Be sure the vehicle is fully stopped before attempting to shift the selector lever

from or to "P" or "R".

This automatic transmission is designed so that the foot brake pedal **MUST** be depressed before shifting from "P" to any drive position while the ignition switch is "ON".

The selector lever cannot be moved out of "P" and into any of the other gear positions if the ignition key is turned to the "LOCK" position or if the key is removed from the switch.

1. Keep the foot brake pedal depressed and push the selector lever button to shift into a driving gear.
2. Release the parking brake and foot brake, then gradually start the vehicle in motion.

When the battery charge is low, the selector lever can be moved if the ignition switch is in the "ACC" position.



WARNING

- *Do not depress the accelerator pedal while shifting from "P" or "N" to "R", "D", "2" or "1". Always depress the brake pedal until shifting is completed. Failure to do so could cause you to lose control and have an accident.*
- *Cold engine idle speed is higher, so use caution when shifting into a forward or reverse gear before the engine has warmed up.*
- *Never shift to "P" or "R" while the vehicle is moving. This could cause an accident.*

STARTING AND DRIVING

- *On slippery roads, do not down-shift. This may cause a loss of control.*

CAUTION

When stopping the vehicle on an uphill grade, do not hold the vehicle by depressing the accelerator pedal. The foot brakes should be used for this purpose.

Shifting from “P” (Park)

If the ignition switch is in the “ON” position and the foot brake pedal is depressed, but the selector lever still cannot be moved out of “P” (Park), follow these instructions:

1. Shut the engine off and remove the key.
2. Apply the parking brake.

3. Reinsert the ignition key and turn it clockwise to the “ACC” position.
4. Depress the brake pedal, move the selector lever to “N” (Neutral) and start the engine.
5. Check stop light operation.

WARNING

If the selector lever cannot be moved from the “P” position while the engine is running and the brake pedal depressed, the stop lights may not work. Malfunctioning stop lights could cause an accident injuring yourself and others.

These instructions for starting the vehicle in “N” (Neutral) should only be used until service can be obtained. Never drive the vehicle if the stop lights are not operating properly.

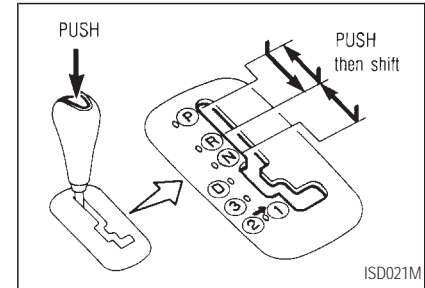

Push the button to shift into “P”, or from “N” to “R” and “P” to “R”. All other positions can be selected without pushing the button.

STARTING AND DRIVING

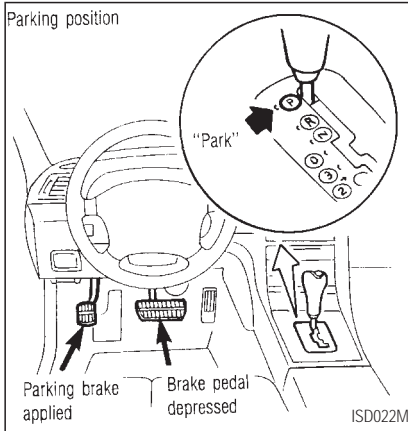

"P" (Park):

Use this selector position when the vehicle is parked or when starting the engine. Make sure the vehicle is completely stopped. For maximum safety, depress the brake pedal, then push in the select lever button and move the lever to the "P" position. Apply the parking

brake. When parking on a hill, apply the parking brake first, then shift the lever into the "P" position.

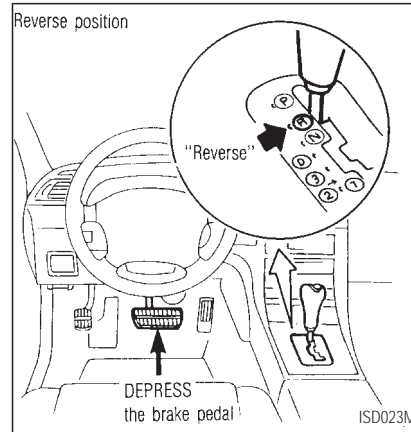

"R" (Reverse):

Use this position to back up. Always be sure the vehicle is completely stopped when selecting "R". With the brake pedal depressed,

push in the select lever button and move the lever to the "R" position.

"N" (Neutral):

Neither forward nor reverse gear is engaged. The engine can be started in this position. To restart a stalled engine while the vehicle is moving, use "N" only.

"D" (Drive):

Use this position for all normal forward driving.

"3" (Third gear):

Use for driving up and down long slopes where engine "braking" would be advantageous.

"2" (Second gear):

Use for hill climbing or engine braking on downhill grades.

Do not downshift into the "2" position at speeds over 62 MPH (100 km/h). Do not ex-

STARTING AND DRIVING

ceed 62 MPH (100 km/h) in the “2” position.

“1” (Low gear):

Use this position when climbing steep hills slowly or driving slowly through deep snow, sand or mud, or for maximum engine braking on steep downhill grades.

Do not shift into the “1” position at speeds over 62 MPH (100 km/h). Do not exceed 25 MPH (40 km/h) in the “1” position.

Accelerator downshift — In “D” position —

For passing or hill climbing, fully depress the accelerator pedal to the floor. This shifts the transmission down into second gear or first gear, depending on the vehicle speed.

Overdrive position

For normal driving move the shift lever to the “D” position. The transmission is upshifted into OVERDRIVE as the vehicle speed increases. To cancel the overdrive, move the

shift lever to “3” position.

When cruising at a low speed or climbing a gentle slope, you may feel uncomfortable shift shocks as the transmission shifts between 3rd and overdrive repeatedly. In this case, move the shift lever to the “3” position.

When driving conditions change, reset the shift lever in the “D” position

The overdrive will not engage until the engine has warmed up.

Remember not to drive at high speeds for extended periods of time with the shift lever in the “3” position. This reduces the fuel economy.

Fail-safe

When Fail-safe operation occurs, i.e., if the power train control module senses a malfunction in any of the A/T circuits, the next time the key is turned to the “ON” position, the AT Check light will blink for approximately 8

seconds after coming on for 2 seconds. While the vehicle can be driven under these circumstances please note that the gears in the automatic transmission will be locked in third gear.

If the vehicle is driven under extreme conditions, such as excessive wheel spinning and subsequent hard braking, the Fail-safe system may be activated. This will occur even if all electrical circuits are functioning properly. In this case, turn the ignition key “OFF” and wait for 3 seconds. Then turn the key back to the “ON” position. The vehicle should return to its normal operating condition. If it does not return to its normal operating condition have your INFINITI dealer check the transmission and repair if necessary.

STARTING THE ENGINE

1. Apply the parking brake.

STARTING AND DRIVING

2. Move the selector lever to "P" (Park) or "N" (Neutral). ("P" preferred.)

NOTE:

The shift lever cannot be moved out of "P" and into any of the other gear positions if the ignition key is turned to "OFF" or if the key is removed from the switch.

The starter is designed not to operate if the selector lever is in one of the driving positions.

3. Crank the engine **with your foot off the accelerator pedal** by turning the ignition key to "START". Release the key when the engine starts. If the engine starts, but fails to run, repeat the above procedure.

— If the engine is very hard to start in extremely cold or hot weather, depress the accelerator pedal and hold it to help start the engine.



CAUTION

Do not operate the starter for more than 15 seconds at a time. If the engine does not start, turn the key off and wait 10 seconds before cranking again, otherwise the starter could be damaged.

4. Warm-up

Allow the engine to idle for at least 30 seconds after starting. Drive at moderate speed for a short distance first, especially in cold weather.

PARKING BRAKE

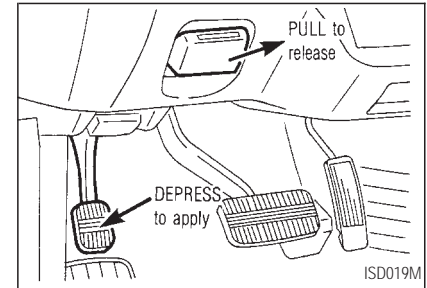

To apply: Fully depress the parking brake pedal.

To release:

1. Firmly apply foot brake.
2. Move the selector lever to the "P" (Park) position.
3. Pull the release lever.
4. Before driving, be sure the brake warning light goes out.



WARNING

- *Be sure the parking brake is fully released before driving. Failure to do so can cause brake failure and lead to an accident.*
- *Do not release the parking brake from outside the vehicle.*
- *Do not use the gear shift in place of the parking brake. When parking, be sure the parking brake is fully engaged.*
- *Do not leave children unattended in a vehicle. They could release the parking brake and cause an accident.*

CRUISE CONTROL

The cruise control allows driving at a speed

STARTING AND DRIVING

between 30 to 89 MPH (48 to 144 km/h) without keeping your foot on the accelerator pedal.

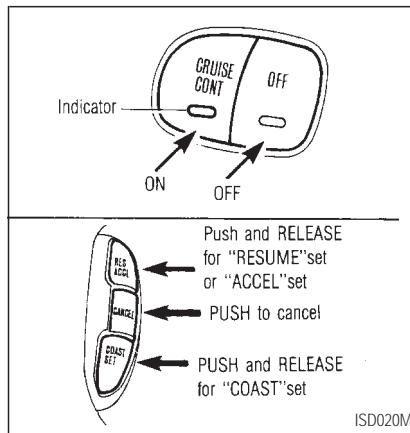

To turn on the cruise control, push the main switch on. The indicator light on the switch will come on.

To set cruising speed, accelerate your vehicle to the desired speed, push the COAST/SET switch and release it. (The "CRUISE" light will come on.) Take your foot off the accelerator pedal. Your vehicle will maintain the set speed.

- **When passing a vehicle**, depress the accelerator pedal. When you release the pedal, the vehicle will return to the previously set speed.
- The vehicle may not maintain the set speed when going up or down steep hills. If this happens, drive without the cruise control.

To cancel the preset speed, follow any of these methods:

- a) Push the cancel button; The "CRUISE" light will go out.

STARTING AND DRIVING

- b) Tap the brake pedal; The “CRUISE” light will go out.
- c) Turn the main switch off. Both the “ON” indicator and “CRUISE” lights will go out.

The cruise control is automatically cancelled and the “CRUISE” light goes out if:

- You depress the brake pedal while pushing the “ACCEL” set switch.
- The vehicle slows down more than 8 MPH (13 km/h) below the set speed.
- You depress the clutch pedal (manual transmission), or move the shift lever to “N” (automatic transmission).

To reset at a faster cruising speed, use one of the following methods:

- a) Depress the accelerator pedal. When the vehicle attains the desired speed, push and release the “COAST/SET” switch.
- b) Push and hold the “ACCEL” set switch.

When the vehicle attains the speed you desire, release the switch.

- c) Push, then quickly release the “ACCEL” set switch. Each time you do this, the set speed will increase by about 1 MPH (1.6 km/h).

To reset at a slower cruising speed, use one of the following methods:

- a) Lightly tap the brake pedal. When the vehicle attains the desired speed, push the “COAST/SET” switch and release it.
- b) Push and hold the “COAST/SET” switch. Release the switch when the vehicle slows down to the desired speed.
- c) Push, then quickly release the “COAST/SET” switch. Each time you do this, the set speed will decrease by about 1 MPH (1.6 km/h).

To resume the preset speed, push and release the “RESUME” set switch. The vehicle

will resume the last set cruising speed when the vehicle speed is over 30 MPH (48 km/h).

Precautions

- If the cruise control system malfunctions, it will cancel automatically. The cruise indicator in the meter assembly will then blink to warn the driver.
- If the cruise indicator blinks, turn the cruise control switch (Main switch) “OFF” and have the system checked by your INFINITI dealer.
- The cruise indicator may sometimes blink when the cruise control switch (Main switch) is turned “ON” while pushing the “ACCEL/RESUME” switch or “COAST/SET” switch or “CANCEL” switch (located on the steering wheel). To properly set the cruise control system, perform the steps above in the order indicated.

STARTING AND DRIVING



WARNING

Do not use the cruise control when driving under the following conditions:

- *it is not possible to keep the vehicle at a set speed.*
- *in heavy traffic or in traffic that varies in speed.*
- *on winding or hilly roads.*
- *on slippery roads (rain, snow, ice, etc.).*
- *in very windy areas.*

Doing so could cause a loss of vehicle control and result in an accident.

BREAK-IN SCHEDULE

Your driving habits during the first 1,000 miles (1,600 km) of vehicle operation are important to the future reliability and economy of your new INFINITI. Listed below are driving recommendations that will allow proper break-in of engine components. Driving the vehicle too hard during the break-in may result in vehicle damage or shortened engine life.

- Do not drive over 55 MPH (90 km/h) and do not run the engine over 4,000 rpm. Avoid driving for long periods at constant speed, either fast or slow.
- Do not accelerate at full throttle in any gear.
- Avoid quick starts.
- Avoid hard braking as much as possible.
- Do not tow a trailer for the first 500 miles (800 km).

ECONOMY HINTS

- Accelerate slowly and smoothly. Maintain cruising speeds with a constant accelerator position.
- Drive at moderate speeds on the highway.
- Avoid unnecessary stopping and braking. Keep a safe distance behind other vehicles.
- Select a gear range suitable to road conditions.
- Avoid unnecessary prolonged engine idling.
- Keep your engine tuned up.
- Follow the recommended periodic maintenance schedule.
- Keep the tires inflated at the correct pressure. Improper tire pressure will increase wear and waste fuel.
- Make sure the front wheels are properly aligned. Improper alignment will cause

STARTING AND DRIVING

premature tire wear and lower fuel economy.

- Air conditioner operation lowers fuel economy. Use the air conditioner only when necessary.
- When cruising at highway speeds, it is more economical to use the air conditioner and leave the windows closed to reduce drag.

PARKING/PARKING ON HILLS

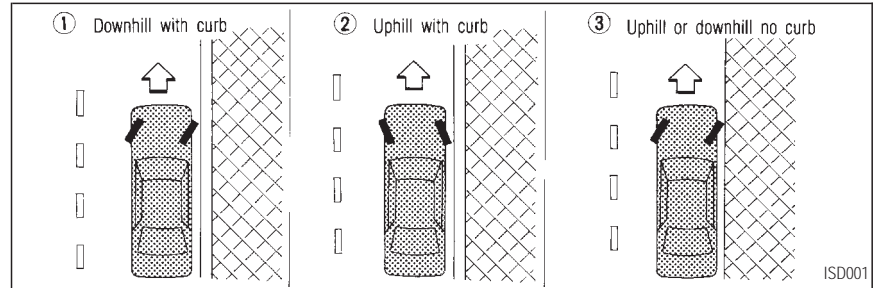

WARNING

Do not park the vehicle over flammable materials such as dry grass, waste paper or rags. They may ignite and cause a fire.

1. Firmly apply the parking brake.

2. Move the selector lever to the "P" (PARK) position.

WARNING

Safe parking procedures require that both the parking brake be set and the transmission placed into the "P"

position. Failure to do so could cause the vehicle to move unexpectedly or roll away and result in an accident. Make sure the selector lever has been pushed as far forward as it can go and cannot be moved.

3. To help prevent the vehicle from rolling into the street when parked on a sloping drive way, it is a good practice to turn the wheels as illustrated.
 - HEADED DOWNHILL WITH CURB:①
Turn the wheels into the curb and move the vehicle forward until the curb side wheel gently touches the curb.
 - HEADED UPHILL WITH CURB:②
Turn the wheels away from the curb and move the vehicle back until the curb side wheel gently touches the curb.

STARTING AND DRIVING

- HEADED UPHILL OR DOWNHILL, NO CURB:③
Turn the wheels toward the side of the road so the vehicle will move away from the center of the road if it moves.
- 4. Turn the ignition key to the "LOCK" position and remove the key.



WARNING

- **Never leave the engine running while the vehicle is unattended.**
- **Never leave children unattended in the vehicle.**

POWER ASSISTED SYSTEM

The power assisted steering is designed to use a hydraulic pump, driven by the engine, to assist steering.

If the engine stops or the drive belt breaks, you will still have control of the vehicle. However, much greater steering effort is needed, especially in sharp turns or at low speeds.

BRAKE SYSTEM

The brake system has two separate hydraulic circuits. If one circuit develops a problem, you will still have braking at two wheels.

- **Vacuum assisted brake:**

The brake booster aids braking by using engine vacuum. If the engine stops, you can stop the vehicle by depressing the brake pedal. However, greater foot pressure on the brake pedal will be required to stop the vehicle and the stopping distance will be longer.

- **Wet brakes:**

When the vehicle is washed or driven through water, the brakes may get wet. As a result, your braking distance will be longer and the

STARTING AND DRIVING

vehicle may pull to one side during braking.

To dry brakes, drive the vehicle at a safe speed while lightly pressing the brake pedal to heat-up the brakes. Do this until the brakes return to normal. Avoid driving the vehicle at high speeds until the brakes function correctly.

● Using the brakes

Avoid resting your foot on the brake pedal while driving. This will overheat the brakes, increases wear on the brake linings and pads, and reduces gas mileage.

To help save the brakes and to prevent the brakes from overheating, reduce speed and downshift to a lower gear before going down a slope or long grade. Overheated brakes may reduce braking performance and could result in loss of vehicle control.



WARNING

While driving on a slippery surface, be careful when braking, accelerating or downshifting. Abrupt braking or accelerating could cause the wheels to skid and result in an accident.

● Parking brake bedding

The parking brake shoes must be “bedded down” whenever the stopping effect of the parking brake is weakened or whenever the parking brake shoes and/or drums are replaced, in order to assure the best braking performance.

This procedure is described in the Vehicle service manual and can be performed by your INFINITI dealer.

ANTI-LOCK BRAKE SYSTEM

The anti-lock brake system controls the brakes at each wheel so the wheels will not lock when braking abruptly or when braking on slippery surfaces. The system detects the rotation speed at each wheel and varies the brake fluid pressure to prevent each wheel from locking. By preventing wheel lockup, the system helps the driver maintain steering control and helps to minimize swerving and spinning on slippery surfaces.

Using the system

Depress the brake pedal and hold it down.



WARNING

Do not pump the brake pedal. Doing so may result in increased stopping distances.

STARTING AND DRIVING

Normal operation

The anti-lock brake system will not operate at speeds below 3 to 6 MPH (5 to 10 km/h) to completely stop the vehicle. (The speeds will vary according to road conditions.) When the anti-lock system senses that one or more wheels are close to locking up, the actuator (under the hood) rapidly applies and releases hydraulic pressure (like pumping the brakes very quickly). While the actuator is working, you may feel a pulsation in the brake pedal and hear a noise or vibration from the actuator under the hood. This is normal and indicates that the anti-lock system is working properly. However, the pulsation may indicate that road conditions are hazardous and extra care is required while driving.

Self-test feature

The anti-lock brake system consists of electronic sensors, electric pumps, and hydraulic solenoids controlled by a computer. The

computer has a built-in diagnostic feature that tests the system each time you start the engine and move the vehicle at a low speed in forward or reverse. When the “self-test” occurs, you may hear a “clank” noise and/or feel a “pulsation” in the brake pedal. This is normal and is not an indication of any malfunction. If the computer senses any malfunction, it switches the anti-lock brake system OFF and turns on the “ANTI-LOCK” brake warning light in the dashboard. The brake system will then behave normally, but without anti-lock assistance.

If the light comes on during the self check, or while you are driving, you should take your vehicle to your INFINITI dealer for repair at your earliest convenience.



WARNING

The anti-lock brake system is a so-

phisticated device, but it cannot prevent accidents resulting from careless or dangerous driving techniques. It can help maintain vehicle control during braking on slippery surfaces, but remember that the stopping distance on slippery surfaces will be longer than on normal surfaces, even with the anti-lock system. Stopping distances may also be longer on rough, gravel or snow covered roads, or if you are using tire chains. Always maintain a safe distance from the vehicle in front of you. Ultimately, the responsibility for safety of self and others rests in the hands of the driver.

Tire type and condition may also affect braking effectiveness.

STARTING AND DRIVING

- **When replacing tires, install the specified size of tires on all 4 wheels.**
- **When installing a spare tire, make sure it is the proper size and type as specified on the tire placard. For tire placard location information, refer to “Tire placard” in the “Technical and consumer information” section of this owner’s manual.**

COLD WEATHER DRIVING

Freeing a frozen door lock

To prevent a door lock from freezing, apply de-icer or glycerin through the key hole. If the lock becomes frozen, heat the key before inserting it into the key hole.

Anti-freeze

When it is anticipated that the temperature will drop below 32°F (0°C), check the anti-freeze (ethylene glycol base) to assure proper winter protection. For details, see “Engine cooling system” in the “Do-it-yourself” section.

Battery

If the battery is not fully charged during extremely cold weather conditions, the battery fluid may freeze and damage the battery. To maintain maximum efficiency, the battery should be checked regularly. For details, see “Battery” in the “Do-it-yourself” section.

Draining of coolant water

If the vehicle is to be left outside without anti-freeze, drain the cooling system by opening the drain valves located under the radiator and on the engine block. Refill before operating the vehicle. See “Changing engine coolant” in the “Do-it-yourself” section.

Tire equipment

1. SUMMER tires are of a tread design to provide superior performance on dry pavement. However, the performance of these tires will be substantially reduced in snowy and icy conditions. If you operate your vehicle on snowy or icy roads, INFINITI recommends the use of MUD & SNOW or ALL SEASON tires on all four wheels. Please consult your INFINITI dealer for the tire type, size, speed rating and availability information.
2. For additional traction on icy roads, studded tires may be used. However, some provinces and states prohibit their use. Check local, state and provincial laws before installing studded tires.

Skid and traction capabilities of studded snow tires, on wet or dry surfaces, may be poorer than that of non-studded snow tires.

STARTING AND DRIVING

3. Tire chains may be used if desired. Make sure they are of proper size for the tires on your vehicle and are installed according to the chain manufacturer's suggestions.

Use of tire chains may be prohibited according to location. Check the local laws before installing tire chains. When installing tire chains, make sure they are of proper size for the tires on your vehicle and are installed according to the chain manufacturer's suggestions. **Use only SAE Class "S" chains.** Other types may damage your vehicle. Use chain tensioners when recommended by the tire chain manufacturer to ensure a tight fit. Loose end links of the tire chain must be secured or removed to prevent the possibility of whipping action damage to the fenders or underbody. If possible, avoid fully loading your vehicle when using tire chains. In addition, drive at a reduced speed. Otherwise, your vehicle may be damaged and/or vehicle han-

dling and performance may be adversely affected.

Never install tire chains on T-type spare tires. Do not use tire chains on dry roads.

Special winter equipment

It is recommended that the following items be carried in the vehicle during winter:

1. A scraper and stiff-bristled brush to remove ice and snow from the windows and wiper blades.
2. A sturdy, flat board to be placed under the jack to give it firm support.
3. A shovel to dig the vehicle out of snow-drifts.
4. Extra window washer fluid to refill the reservoir tank.

Driving on snow or ice



WARNING

- *Wet ice (32°F, 0°C and freezing rain), very cold snow or ice can be slick and very hard to drive on. The vehicle will have a lot less traction or "grip" under these conditions. Try to avoid driving on wet ice until the road is salted or sanded.*
- *Whatever the condition, drive with caution. Accelerate and slow down with care. If accelerating or downshifting too fast, the drive wheels will lose even more traction.*
- *Allow more stopping distance under these conditions. Braking should be started sooner than on*

STARTING AND DRIVING

dry pavement.

- *Allow greater following distances on slippery roads.*
- *Watch for slippery spots (glare ice). These may appear on an otherwise clear road in shaded areas. If a patch of ice is seen ahead, brake before reaching it. Try not to brake while actually on the ice, and avoid any sudden steering maneuvers.*
- *Do not use cruise control on slippery roads.*
- *Snow can trap dangerous exhaust gases under your vehicle. Keep snow clear of the exhaust pipe and from around your vehicle.*

Engine block heater/Engine heater (if so equipped)

An engine block heater/engine heater to assist extreme cold temperature starting is available through your INFINITI dealer.



WARNING

Do not use your heater with an ungrounded electrical system or two-pronged (cheater) adapters. You can be injured by an electrical shock if you use an ungrounded connection.

5 IN CASE OF EMERGENCY

Roadside assistance program	5-2
Flat tire	5-2
Push starting	5-9
If your vehicle overheats	5-9
Tow truck towing	5-10
Freeing vehicle from sand, snow or mud	5-12

IN CASE OF EMERGENCY

ROADSIDE ASSISTANCE PROGRAM

Every new INFINITI comes with a 4 year, unlimited mileage Roadside Assistance plan. In the event of a roadside emergency, Roadside Assistance Service is available to you. Please refer to your Warranty Booklet for details. Both the Warranty Booklet and Roadside Assistance Calling Card in your Owner's Literature Portfolio provide the Toll-Free Number to call for assistance. Roadside Assistance is provided 24 hours a day, 365 days a year, for four years from the date sold to give emergency roadside help, in the event of mechanical or nonmechanical trouble(s) such as flat tires, out-of-gas, dead battery, lost keys mechanical breakdown, accident, etc.

FLAT TIRE

If you have a flat tire, follow the instructions below.

Stopping the vehicle

1. Safely move the vehicle off the road and away from traffic.
2. Turn on the hazard warning flashers.
3. Park on a level surface and apply the parking brake. Shift the automatic transmission to "P".
4. Turn off the engine.
5. Raise the hood to warn other traffic, and to signal professional road assistance personnel that you need help.
6. Have all passengers get out of the vehicle and stand in a safe place, away from traffic and clear of the vehicle.



WARNING

- ***Make sure that the parking brake is securely applied and the automatic transmission into P (Park).***
- ***Never change tires when the vehicle is on a slope, ice or slippery areas. This is hazardous.***
- ***Never change tires if oncoming traffic is close to your vehicle. Wait for professional road assistance.***

If needed, Roadside Assistance is available. Please refer to your Warranty Booklet or Roadside Assistance I.D. Card for the toll-free number to call.

IN CASE OF EMERGENCY

Getting the spare tire and tools

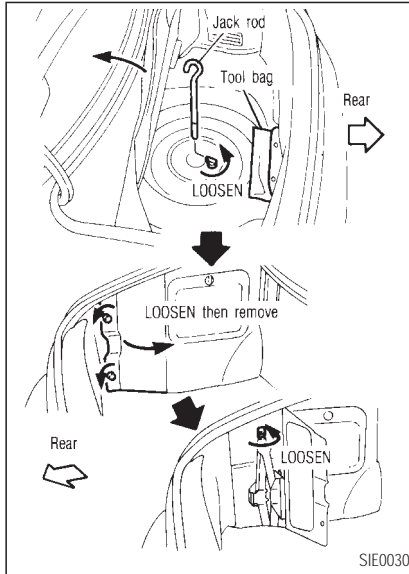

Remove jacking tools and spare tire from storage area.

If the spare wheel clamp cannot be moved easily, use the jack rod as shown.

Blocking wheels

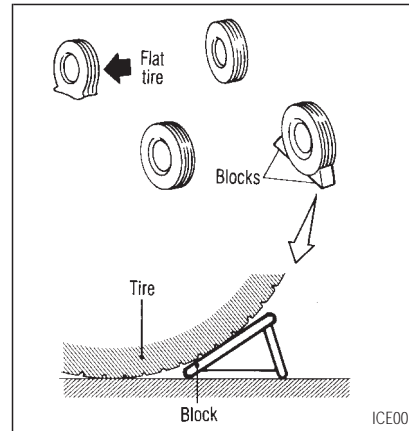

Place suitable blocks at both the front and back of the wheel diagonally opposite the flat

tire to prevent the vehicle from rolling when it is jacked up.



WARNING

Be sure to block the wheel as the vehicle may move and cause personal injury.

Removing wheel cover

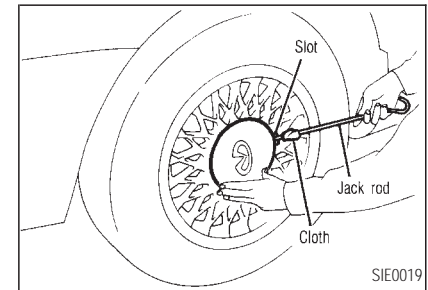

IN CASE OF EMERGENCY

CAUTION

Do not use hands to pry off wheel cover. Doing so could result in personal injury.

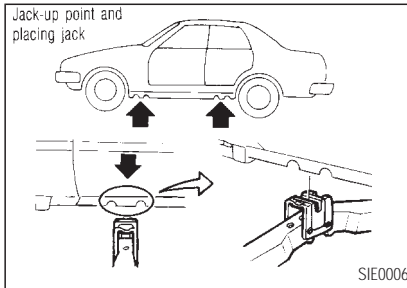

Jacking up and removing wheel

Carefully read the caution label attached to the jack body and the following instructions.

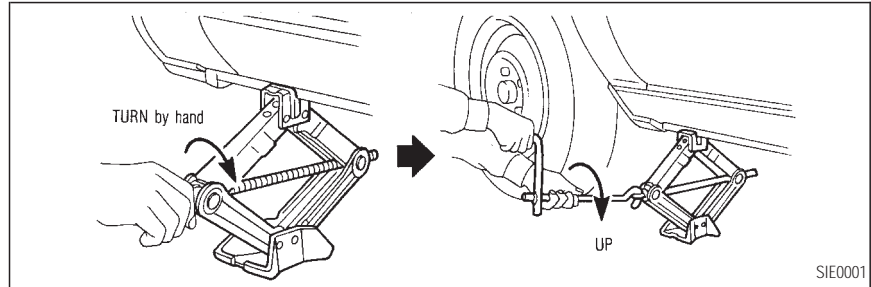

1. Place the jack directly under the jack-up point as illustrated above so that top of the jack contacts the vehicle at the jack up point. Align the center of both the jack head and the notch at the jack up point as shown. Also fit the notched portion of the vehicle in the groove of the jack head as shown.

The jack should be used on level firm ground.

2. Loosen each wheel nut one or two turns by turning counterclockwise with the wheel

nut wrench. **Do not remove the wheel nuts until the tire is off the ground.**

3. Carefully raise the vehicle until the tire clears the ground. To lift the vehicle securely hold the jack lever and rod with both hands as shown above. Remove the wheel nuts, and then remove the tire.

IN CASE OF EMERGENCY



WARNING

- Never get under the vehicle while it is supported only by the jack.
- Use the jack provided with your vehicle. Do not use the jack provided with your vehicle on other vehicles. The jack is designed only for lifting your vehicle during a tire change.
- Use the correct jack up points; never use any other part of the vehicle for jack support.
- Never jack up the vehicle more than necessary.
- Never use blocks on or under the jack.

- Do not start or run engine while vehicle is on the jack.
- Do not allow passengers to stay in the vehicle while it is on the jack.
- Never run the engine with the wheels off the ground. It may cause the vehicle to move.

Installing wheel

1. Clean mud or dirt from the surface between the wheel and hub.
2. Carefully put the wheel on and tighten the wheel nuts finger tight.

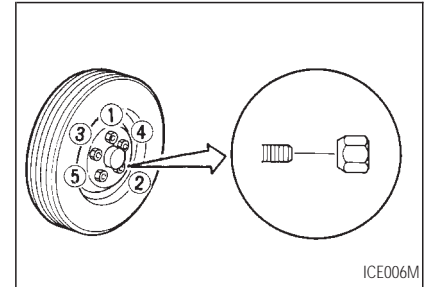

3. With the wheel nut wrench, tighten wheel nuts alternately and evenly until they are tight.
4. Lower the vehicle slowly until the tire touches the ground. Then, with the wheel nut wrench, tighten the wheel nuts securely in the sequence as illustrated.

IN CASE OF EMERGENCY

As soon as possible tighten the wheel nuts to the specified torque with a torque wrench.

Wheel nut tightening torque:

72 to 87 ft-lb
(98 to 118 N·m)



WARNING

- *Incorrect wheel nuts or improperly tightened wheel nuts can cause the wheel to become loose or come off. This could cause an accident.*
- *Do not use oil or grease on the wheel studs or nuts. This could cause the nuts to become loose.*

Adjust tire pressure to the COLD pressure.

COLD pressure:

After vehicle has been parked for three hours or more or driven less than 1 mile (1.6 km).

COLD tire pressures are shown on the tire placard affixed to the center console lid.

- Retighten the wheel nuts when the vehicle has been run for 600 miles (1,000 km) after installing an aluminum wheel.

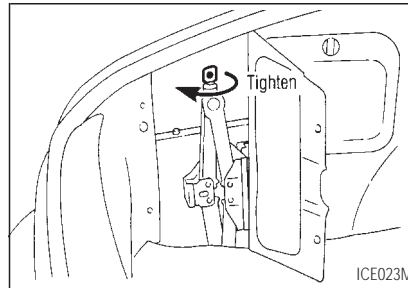

5. Securely store the spare tire and jacking

equipment in the vehicle.



WARNING

- *Always make sure that the spare tire and jacking equipment are properly secured after use. Such items can become dangerous projectiles in an accident or sudden stop.*
- *The T-type spare tire and small size spare tire are designed for emergency use. See specific instructions under the heading "Wheel and tire" in the "Do-it-yourself" section.*

JUMP STARTING

To start your engine with a booster battery, the instructions and precautions below must be followed.

IN CASE OF EMERGENCY



WARNING

- *If done incorrectly, jump starting can lead to a battery explosion, resulting in severe injury or death. It could also damage your vehicle.*
- *Explosive hydrogen gas is always present in the vicinity of the battery. Keep all sparks and flames away from the battery.*
- *Do not allow battery fluid to come into contact with eyes, skin, cloth or painted surfaces. Battery fluid is a corrosive sulphuric acid solution which can cause severe burns. If the fluid should come into contact with anything, immediately flush the contacted area with water.*

- *Keep battery out of the reach of children.*
- *The booster battery must be rated at 12 volts. Use of an improperly rated battery can damage your vehicle.*
- *Whenever working on or near a battery, always wear suitable eye protectors (e.g., goggles or industrial safety spectacles) and remove rings, metal bands, or any other metal jewelry. Do not lean over battery when jump starting.*
- *Never attempt to jump start a vehicle with a frozen battery. The battery could rupture and explode. If you suspect a frozen battery, remove the vent caps and check the fluid. If there seems to*

be no fluid, or if you see ice, do not attempt a jump start until the fluid thaws.

- *Do not attempt to jump start a frozen battery. It could explode and cause serious injury.*
- *Your vehicle has an automatic engine cooling fan. It could come on at any time. Keep hands and other objects away from it.*

If needed, Roadside Assistance is available. Please refer to your Warranty Information Booklet or Roadside Assistance I.D. Card for the toll-free number to call.



CAUTION

Always follow the instructions be-

low. Failure to do so could result in damage to the charging system and cause personal injury.

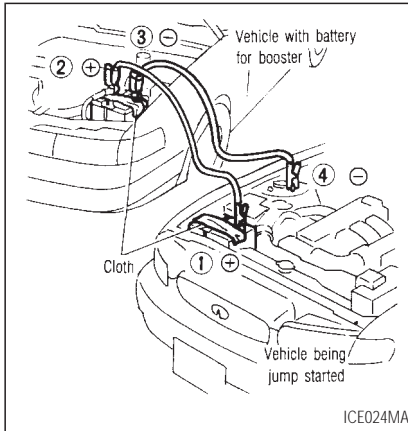

1. If the booster battery is in another vehicle, position the two vehicles to bring their

IN CASE OF EMERGENCY

batteries into close proximity to each other.

Do not allow the two vehicles to touch.

2. Apply parking brake. Move the selector lever to "P" (Park). Switch off all unnecessary electrical systems (light, heater, air conditioner, etc.).
3. Remove vent caps on the battery (if so equipped). Cover the battery with an old cloth to reduce explosion hazard.
4. Connect jumper cables in the sequence as illustrated.

CAUTION

- **Always connect positive (+) to positive (+) and negative (-) to body ground (e.g., strut mounting**

bolt, etc. — not to the battery).

- **Make sure that cables do not touch moving parts in the engine compartment and that clamps do not contact any other metal.**
5. Start the engine of the other vehicle and let it run for a few minutes.
 6. Keep the engine speed of the other vehicle at about 2,000 rpm, and start your engine in the normal manner.

CAUTION

Do not engage the starter motor for more than 10 seconds. If the engine does not start right away, turn the key off and wait 3 to 4 seconds before trying again.

7. After starting your engine, carefully disconnect the negative cable and then the positive cable.
8. Replace the vent caps (if so equipped). Be sure to dispose of the cloth used to cover the vent holes as it may be contaminated with corrosive acid.

PUSH STARTING



CAUTION

- *This model cannot be push started. This may cause transmission damage.*
- *Three-way catalyst equipped models should not be started by pushing since the three-way catalyst may be damaged.*
- *Never try to start the vehicle by*

IN CASE OF EMERGENCY

towing it; when the engine starts, the forward surge could cause the vehicle to collide with the tow vehicle.

If needed, Roadside Assistance is available. Please refer to your Warranty Booklet or Roadside Assistance I.D. Card for the toll-free number to call.

IF YOUR VEHICLE OVERHEATS

If your vehicle is overheating (indicated by an extremely high temperature gauge reading), or if you feel a lack of engine power, detect abnormal noise, etc., take the following steps:



WARNING

- *Do not continue to drive if your vehicle overheats. Doing so could cause a vehicle fire.*
- *To avoid the danger of being scalded, never remove the radiator cap while the engine is still hot. When the radiator cap is removed, pressurized hot water will spurt out, possibly causing serious injury.*
- *Do not open the hood if steam is coming out.*

1. Move the vehicle safely off the road, apply the parking brake and move the shift lever to "P".

Do not stop the engine.

IN CASE OF EMERGENCY

2. Turn off the air conditioner switch. Open all the windows, move the heater or air conditioner temperature control to "maximum hot" and fan control to "high speed".
3. If engine overheating is caused by climbing a long hill on a hot day, run the engine at a fast idle (approximately 1,500 rpm) until the temperature gauge indication returns to normal.
4. Get out of the vehicle. Look and listen for steam or coolant escaping from the radiator before opening the hood. Wait until no steam or coolant can be seen before proceeding.
5. Open the engine hood.



WARNING

If steam or water is coming from the engine, stand clear to prevent get-

ting burned.

6. Visually check drive belts for damage or looseness. Also check to make sure the cooling fan is running. The radiator hoses and radiator should not leak water. If coolant is leaking, the cooling fan belt is missing or loose, or the cooling fan does not run, stop the engine.



WARNING

- *Be careful not to allow your hands, hair, jewelry or clothing to come into contact with, or to get caught in, the running fan, belts, or motor fan.*
- *The fan motor can start at any time when the coolant temperature is high.*

7. After the engine cools down, check the coolant level in the reservoir tank with the engine running. Add coolant to the reservoir tank if necessary. Have your vehicle repaired at the nearest INFINITI dealer.

If needed, Roadside Assistance is available. Please refer to your Warranty Information Booklet or Roadside Assistance I.D. Card for the toll-free number to call.

TOW TRUCK TOWING

When towing your vehicle, all State (Provincial in Canada) and local regulations for towing must be followed. Incorrect towing equipment could damage your vehicle. Towing instructions are available from your INFINITI dealer. Local service operators will generally be familiar with the applicable laws and procedures for towing. To assure proper towing and to prevent accidental damage to your vehicle, INFINITI recommends that you have a service operator tow your vehicle. It is

IN CASE OF EMERGENCY

advisable to have the service operator carefully read the following precautions.



WARNING

- Never ride in a vehicle that is being towed.
- Never get under your vehicle after it has been lifted by a tow truck.



CAUTION

- When towing, make sure that the transmission, axles, steering system and power train are in working condition. If any unit is damaged, a dolly must be used.
- When towing with the front wheels on the ground: Turn the

ignition key to the "OFF" position and secure the steering wheel in a straight-ahead position with a rope or similar device. Never place the ignition key in the "LOCK" position. This will result in damage to the steering lock mechanism. To move the selector lever to the "N" position, turn the ignition key to the "ACC" position. After moving the shift lever to the "N" position, be sure to turn the ignition key to the "OFF" position.

- Attach safety chains for all towing.

If needed, Roadside Assistance is available. Please refer to your Warranty Information Booklet or Roadside Assistance I.D. Card for the toll-free number to call.

INFINITI recommends that your vehicle be towed with the driving (rear) wheels off the ground as illustrated.

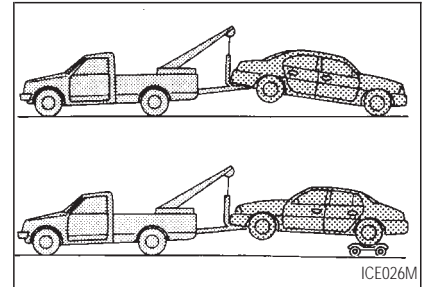

If you have to tow an automatic transmission model with four wheels on ground or with front wheels raised (with rear wheels on ground)

- Release the parking brake move the shift lever to neutral ("N" position) and turn the ignition key to the "ACC" position. After moving the shift lever to neutral ("N"

IN CASE OF EMERGENCY

position), be sure to turn the ignition key to the "OFF" position.

- Observe the following restricted towing speeds and distances.
 - **Speed: Below 30 MPH (50 km/h)**
 - **Distance: Less than 40 miles (65 km)**

If the speed or distance must necessarily be greater, remove the propeller shaft before towing to prevent damage to the transmission.

CAUTION

Never tow an automatic transmission model from the rear (i.e., backward) with four wheels on the ground as this may cause serious

and expensive damage to the transmission.

FREEING VEHICLE FROM SAND, SNOW OR MUD

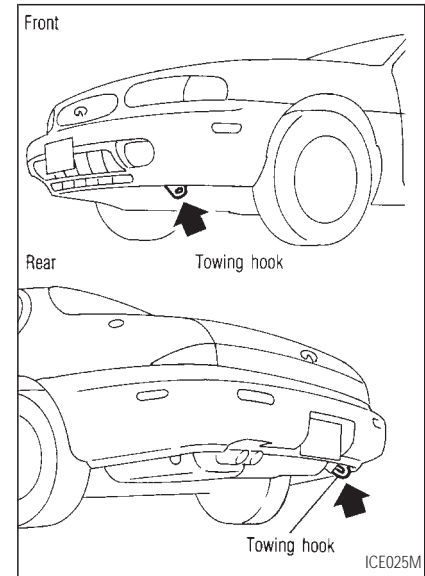

IN CASE OF EMERGENCY

- Use the towing hooks **only** as illustrated, not other parts of the vehicle. Otherwise, the vehicle body will be damaged.
- Use the towing hooks **only** to free a vehicle stuck in sand, snow, mud, etc. **Never** tow the vehicle for a long distance using only the towing hooks.
- The towing hook is under tremendous force when used to free a stuck vehicle. Always pull the cable straight out from the front or rear of the vehicle. **Never** pull on the hook at an angle.
- Stand clear of a stuck vehicle.

be damaged.



WARNING

Do not spin your tires at high speed. This could cause them to explode and result in serious injury. Parts of your vehicle could also overheat and

6 APPEARANCE AND CARE

Cleaning exterior and interior	6-2
Corrosion protection	6-6

APPEARANCE AND CARE

CLEANING EXTERIOR AND INTERIOR

In order to maintain the appearance of your vehicle, it is important to take proper care of it.

In the following cases, please wash your vehicle as soon as possible to protect the paint surface.

- After a rainfall to prevent possible damage from acid rain
- After driving on coastal roads
- When contaminants such as soot, bird droppings, tree sap, metal particles or bugs get on the paint surface
- When dust or mud builds up on the surface

Whenever possible, store or park your vehicle inside a garage or in a covered area.

When it is necessary to park outside, park in

a shady area or protect the vehicle with a body cover.

Be careful not to scratch the paint surface when putting on or removing the body cover.

Washing

Thoroughly rinse surface dirt off the vehicle with a wet sponge and plenty of clean water. Clean the vehicle thoroughly using a mild soap such as Nissan Car Wash, or a general purpose dishwashing liquid mixed with clean, lukewarm (never hot) water. Rinse the vehicle again with plenty of clean water.

Inside flanges, seams and folds on the doors, hatches and hood are particularly vulnerable to the effects of road salt. Therefore, these areas must be regularly cleaned. Make sure that the drain holes in the lower edge of the door are open. Spray water under the body and in the wheel wells to loosen the dirt and wash away road salt.

Avoid leaving water spots on the paint surface by using a damp chamois to dry the vehicle.



CAUTION

- **Do not use strong household soap, strong chemical detergents, gasoline or solvents.**
- **Do not wash the vehicle in direct sunlight or while the vehicle body is hot, as the surface may become water-spotted.**
- **Avoid using tight-napped or rough cloths, such as washing mitts. Care must be taken when removing caked-on dirt or other foreign substance so that the paint surface is not scratched or damaged.**

Waxing

If you wish to wax your vehicle, only use a wax

APPEARANCE AND CARE

specified for use over clear coats, such as Nissan Liquid or Spray Wax, because your INFINITI has been finished with the finest paint and hard clear coats. Your INFINITI dealer can assist you in choosing the proper product.

- Wax your vehicle only after a thorough washing. Follow the instructions supplied with the wax.
- Do not use a wax containing any abrasives, cutting compounds or cleaners that may damage the vehicle finish.
- If the surface does not polish easily, use a “road tar” remover and wax again.

Machine compound or aggressive polishing on a base coat/clear coat paint finish may dull the finish or leave swirl marks.

Removing spots

Remove tar and oil spots, industrial dust, insects, and tree sap as quickly as possible

from the paint surface to avoid lasting damage or staining. Special cleaning products are available at your INFINITI dealer or automotive accessory stores.

Underbody

In areas where road salt is used in winter, the underbody must be cleaned regularly. This will prevent dirt and salt from building up and causing underbody and suspension corrosion. Before the winter period and again in the spring, the underseal must be checked and, if necessary, re-treated.

Cleaning glass

Use glass cleaner to remove smoke and dust film from the glass surfaces. It is normal for glass to become coated with a film after the vehicle is parked in the hot sun. Glass cleaner and a soft cloth will easily remove this film.



CAUTION

When cleaning the inside of the window, do not use sharp-edged tools, abrasive cleaners or chlorine based disinfectant cleaners. They could damage the rear window defogger.

APPEARANCE AND CARE

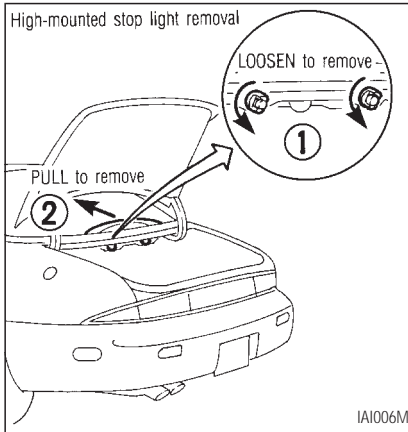

Cleaning aluminum alloy wheels

Wash regularly, especially during winter months in areas where road salt is used. Salt could discolor the wheel if not removed.

Chrome parts

Clean chrome parts regularly with a non-abrasive chrome polish to maintain the finish.

Bumpers and foldable mirrors

INFINITI recommends bumpers and foldable mirror housings be waxed with a non-abrasive wax from time to time to maintain appearance.

Cleaning interior

Occasionally remove loose dust from the interior trim, plastic parts and seats using a vacuum cleaner or soft brush.

When interior trim or seats are stained, clean immediately as follows:

- Wipe clean using a clean, soft damp cloth and a neutral detergent. Wipe off all traces of the detergent with another clean soft damp cloth, finishing with a soft dry cloth.
- If the above method does not remove the stains, etc., rub the affected area using a soft wet brush and a neutral detergent. Wipe off all traces of the detergent with a clean soft damp cloth, finishing with a soft dry cloth.

Before using any fabric protector, read the manufacturer's recommendations. Some fabric protectors contain chemicals that may stain or bleach the seat material.

INFINITI offers vinyl and leather cleaner for more difficult stains or soiled surfaces. See your INFINITI dealer for assistance in choosing the proper product.



CAUTION

- **Never use benzine, thinner, or any similar material.**
- **The leather seats should be regularly coated with a leather wax like saddle soap. Never use car wax.**
- **Never use fabric protectors unless recommended by the manufacturer.**

APPEARANCE AND CARE

Wool moquette material

Quality wool moquette is used for the seat cover, door trim, door armrest and headrest. The moquette seat cover may become partially glazed if exposed to heat or humidity due to the pile being laid flat.

1. Spray water to moisten the glazed portion of the moquette seat cover. (Use of steam is allowed.)
2. Brush the glazed moquette so that the flattened pile of the moquette is raised up allowing moisture to penetrate down to the roots.
3. As the moquette pile is raised, wipe off any moisture lightly using a dry soft cloth. (A heat gun may be used for drying.)



WARNING

Never touch the heating element or hot air outlet of the heat gun as this

may cause scalding.

- Make sure that the moquette has been thoroughly dried after repairing the glazed portion.

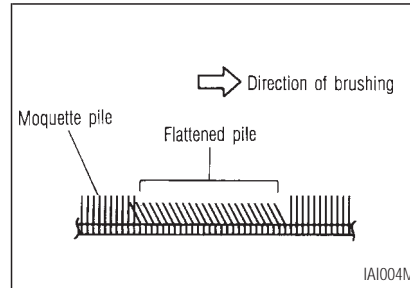

Prolonged exposure to heavy sunlight may cause the moquette to be discolored. Be sure to park your vehicle in the shade, particularly in hotter climate.

Floor mat positioning aid

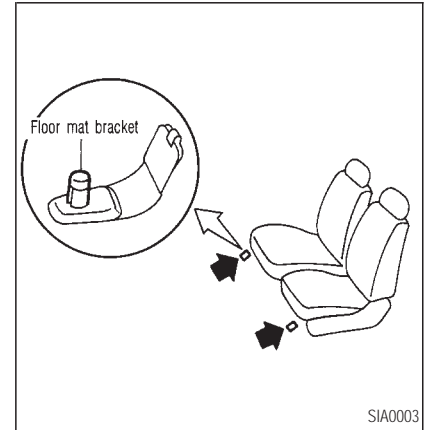

Your INFINITI model includes floor mat brackets to act as floor mat positioning aids. Position the mat and place the floor mat bracket hook through the floor mat grommet hole. Repeat this procedure for both the driver side and front passenger side floor mats.

APPEARANCE AND CARE

Periodically check to make certain that the mats are properly positioned.

Floor mats

The use of genuine floor mats can extend the life of your vehicle carpet and make it easier to clean the interior. **No matter what mats are used, be sure they are fitted for your vehicle and are properly positioned in the footwell to prevent interference with pedal operation.** Mats should be maintained with regular cleaning and replaced if they become excessively worn.

Seat belts

The seat belts can be cleaned by wiping them with a sponge dampened in a mild soap solution. Allow the belts to dry completely before using them.



WARNING

Do not allow wet belts to roll up in the retractor. NEVER use bleach, dye, or chemical solvents since these may severely weaken the seat belt webbing.

CORROSION PROTECTION

Most common factors contributing to vehicle corrosion:

1. The accumulation of moisture-retaining dirt and debris in body panel sections, cavities, and other areas.
2. Damage to paint and other protective coatings caused by gravel and stone chips or minor traffic accidents.

Environmental factors influence the rate of corrosion:

Moisture

Accumulation of sand, dirt and water on the vehicle body underside can accelerate corrosion. Wet floor coverings will not dry completely inside the vehicle, and should be removed for drying to avoid floor panel corrosion.

Relative humidity

Corrosion will be accelerated in areas of high relative humidity, especially those areas where the temperatures stay above freezing where atmospheric pollution exists, or where road salt is used.

Temperature

A temperature increase will accelerate the rate of corrosion to those parts which are not well ventilated.

APPEARANCE AND CARE

Air pollution

Industrial pollution, the presence of salt in the air in coastal areas, or heavy road salt use will accelerate the corrosion process. Road salt will also accelerate the disintegration of paint surfaces.

To protect your vehicle from corrosion:

- Wash your vehicle often to keep the vehicle clean.
- Always check for minor damage to the paint and repair it as soon as possible.
- Keep drain holes at the bottom of the doors open to avoid water accumulation.
- Check the underbody for accumulation of sand, dirt or salt. If present, wash with water as soon as possible.



CAUTION

- ***NEVER remove dirt, sand or other debris from the passenger compartment by washing it out with a hose. Remove dirt with a vacuum cleaner or broom.***
- ***Never allow water or other liquids to come in contact with electronic components inside the vehicle as this may damage them.***
- ***See your INFINITI dealer for assistance.***

7 DO-IT-YOURSELF

Precautions	7-2	Air cleaner	7-17
Engine cooling system	7-5	Wiper blade	7-17
Engine oil	7-8	Parking brake	7-19
Automatic transmission fluid	7-11	Brake pedal	7-19
Power steering fluid	7-13	Brake booster	7-20
Brake fluid	7-13	Fuses	7-20
Window washer fluid	7-14	Fusible links	7-22
Battery	7-14	Light bulbs	7-22
Drive belts	7-15	Wheels and tires	7-30
Spark plug replacement	7-16		

DO-IT-YOURSELF

PRECAUTIONS

When performing any inspection or maintenance work on your vehicle, always take care to prevent serious accidental injury to yourself or damage to the vehicle. The following are general precautions which should be closely observed.



WARNING

- *Park the vehicle on a level surface, apply the parking brake securely and block the wheels to prevent the vehicle from moving. Move the shift lever to "P" (Park).*
- *Be sure to turn the ignition key to the "OFF" or "LOCK" position when performing any replacement or repair.*

- *If you must work with the engine running, keep your hands, clothing, hair and tools away from moving fans, belts and any other moving parts.*
- *It is advisable to remove ties and any jewelry, such as rings, watches, etc. before working on your vehicle.*
- *If you must run the engine in an enclosed space such as a garage, be sure there is proper ventilation for exhaust gases.*
- *Never get under the vehicle while it is supported only by a jack. If it is necessary to work under the vehicle, support it with safety stands.*

- *Keep smoking materials, flame and sparks away from fuel and battery.*
- *The fuel filter or fuel lines should be serviced by an INFINITI dealer because the fuel lines are under high pressure even when the engine is off.*



CAUTION

- *Do not work under the hood while the engine is hot. Turn off the engine and wait until it cools down.*
- *Never connect or disconnect either the battery or any transistorized component connector while*

DO-IT-YOURSELF

the ignition is on.

- *Never leave the engine or the automatic transmission related component harness connector disconnected while the ignition is on.*
- *Avoid direct contact with used engine oil. Improperly disposed motor oil and/or other vehicle fluids can hurt the environment. Always conform to local regulations for disposal of vehicle fluid.*

improper servicing may result in operating difficulties or excessive emissions, and could affect your warranty coverage. **If in doubt about any servicing, have it done by your INFINITI dealer.**

This "Do-it-yourself" section gives instructions regarding only those items which are relatively easy for most owners to perform. More involved service should be done by your INFINITI dealer.

You should be aware that incomplete or

DO-IT-YOURSELF

CHECK LOCATIONS IN ENGINE COMPARTMENT

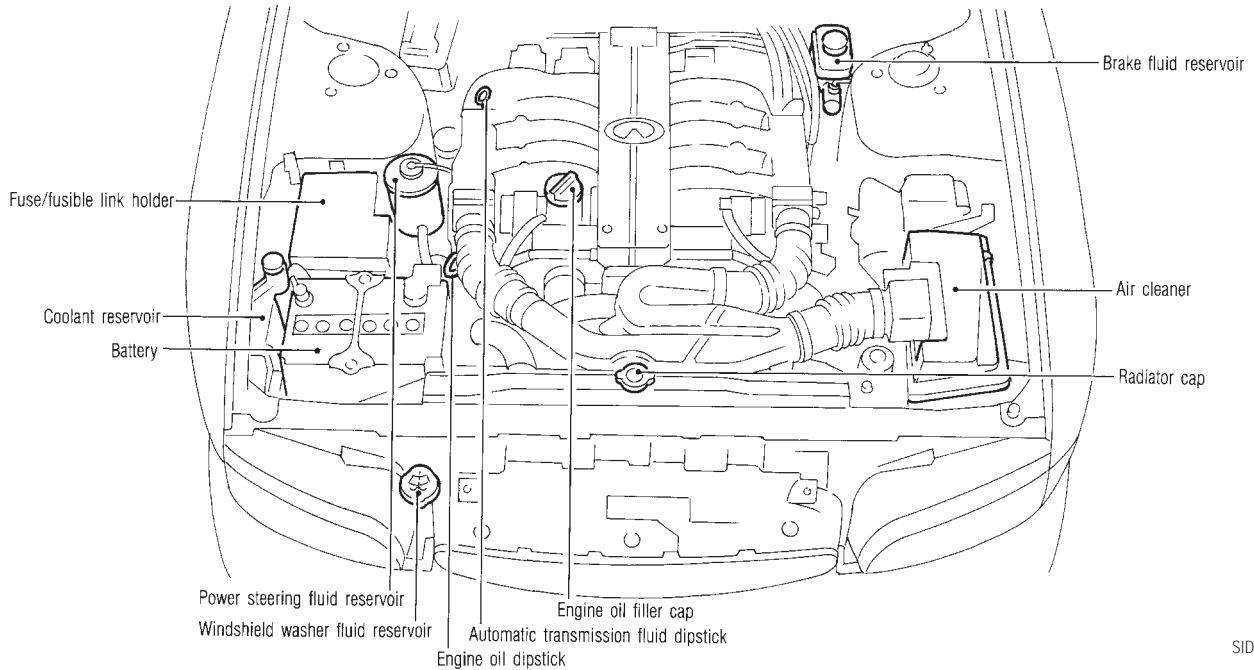

SID0011

DO-IT-YOURSELF

ENGINE COOLING SYSTEM

The engine cooling system is filled at the factory with a high-quality, year-round, anti-freeze coolant solution. The anti-freeze solution contains rust and corrosion inhibitors, therefore additional cooling system additives are not necessary.



CAUTION

When adding or replacing coolant, use only an ethylene glycol anti-freeze with the proper mixture ratio of 50% antifreeze 50% distilled water.

The use of other types of coolant solutions may damage your engine cooling system.

Outside temperature down to		Anti-freeze	Distilled water
°C	°F		
-35	-30	50%	50%



WARNING

- *Never remove the radiator cap when the engine is hot. Serious burns could be caused by high pressure fluid escaping from the radiator.*
- *Wait until the engine and radiator cool down. See precautions in "If your vehicle overheats" found in the "In case of emergency" section.*

- *The radiator is equipped with a pressure cap. Use a genuine cap or its equivalent when replacement is required.*

DO-IT-YOURSELF

CHECKING ENGINE COOLANT LEVEL

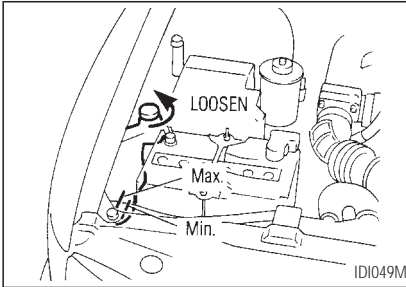

Check the coolant level in the reservoir tank when the engine is cold. If the coolant level is below "MIN", add coolant up to the "MAX" level. If the reservoir tank is empty, check the coolant level in the radiator **when the engine is cold**. If there is insufficient coolant in the radiator, fill the radiator with coolant up to the filler opening and also add it to the reservoir tank up to the "MAX" level.

If the engine cooling system requires

coolant frequently, have it checked by your INFINITI dealer.

CHANGING ENGINE COOLANT

- Major engine cooling system repairs should be performed by your INFINITI dealer. The service procedures can be found in the appropriate INFINITI Service Manual.
- Improper servicing can result in reduced heater performance and engine overheating.

WARNING

- *To avoid the danger of being scalded, never change the coolant when the engine is hot.*
- *Never remove the radiator cap when the engine is hot. Serious*

burns could be caused by high pressure fluid escaping from the radiator.

1. Park the vehicle in the shade and set the temperature set button to the maximum hot temperature after turning the ignition key to the "ON" position.

DO-IT-YOURSELF

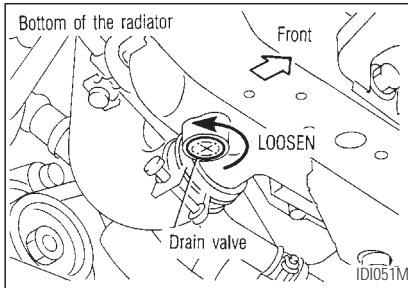
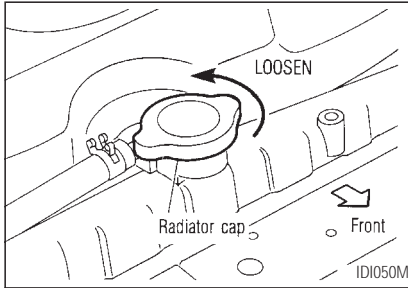

2. Open the radiator cap and drain valve.

Open the drain valves on both sides of the engine block.

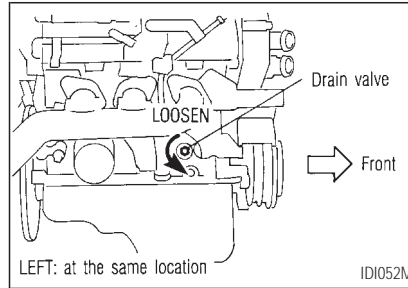

3. Flush the cooling system by running fresh water through the radiator.
4. Close both drain valves securely.
5. See the "Technical information" section for cooling system capacity. Fill the radiator slowly with the proper mixture of coolant and water. Fill the reservoir tank up to the "MAX" level. Then install the radiator cap.
6. Start the engine and warm it up until it

reaches normal operating temperature. Then race the engine 2 or 3 times under no load. Watch the coolant temperature gauge for signs of overheating.

7. Stop the engine. **After it completely cools down**, refill the radiator up to the filler opening. Fill the reservoir tank up to the "MAX" level.
8. Check the drain valve for any sign of leakage.

DO-IT-YOURSELF

ENGINE OIL

CHECKING ENGINE OIL LEVEL

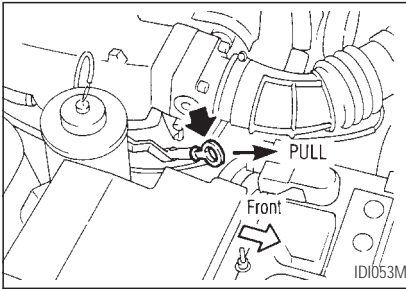

1. Park the vehicle on a level surface and apply parking brake.
2. Run the engine until it reaches operating temperature.
3. Turn off the engine. **Wait a few minutes for the oil to drain back into the oil pan.**

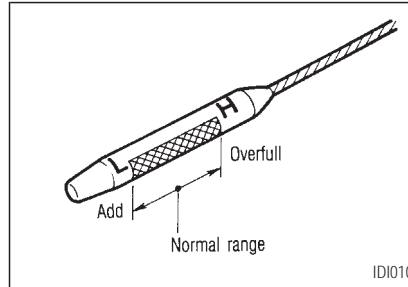

4. Remove the dipstick and wipe it clean. Reinsert it all the way.
5. Remove the dipstick again and check the oil level. It should be between the "H" and "L" marks. If the oil level is below the "L" mark, remove the oil filler cap and pour recommended oil through the opening. **Do not overfill.**
6. Recheck oil level with dipstick.

It is normal to add some oil between oil maintenance intervals or during the

break-in period, depending on the severity of operating conditions.



CAUTION

Oil level should be checked regularly. Operating with insufficient amount of oil can damage the engine, and such damage is not covered by warranty.

DO-IT-YOURSELF

CHANGING ENGINE OIL

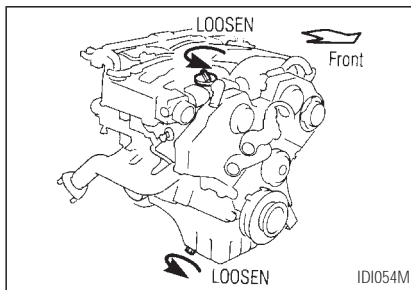

1. Park the vehicle on a level surface and apply the parking brake.
2. Run the engine until it reaches operating temperature, and then turn it off.
3. Place a large drain pan under the drain plug.
4. Remove the oil filler cap.
5. Remove the drain plug with a wrench and completely drain the oil.

If oil filter is to be changed, remove and replace it at this time. See “Changing the oil filter”.



CAUTION

Be careful not to burn yourself. The engine oil will be hot.

Waste oil must be disposed of properly. Check your local regulations.

6. Clean and re-install the drain plug and washer. Tighten the drain plug with a wrench.

**Drain plug tightening torque:
22 to 29 ft-lb
(29 to 39 N·m)**

Do not use excessive force.

7. Refill the engine with recommended oil and install the cap securely.

See the “Technical information” section for oil type and refill capacity.

8. Start the engine.

Check for leakage around the drain plug. Correct as required.

9. Turn the engine off and wait several minutes. Check the oil level. Add engine oil if necessary.

10. Dispose of waste oil in the proper manner.

DO-IT-YOURSELF



WARNING

- *Prolonged and repeated contact with used engine oil may cause skin cancer.*
- *Try to avoid direct skin contact with used oil. If skin contact is made, wash thoroughly with soap or hand cleaner as soon as possible.*
- *Keep used engine oil out of reach of children.*

CHANGING ENGINE OIL FILTER

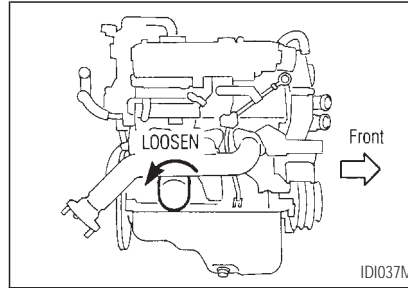

1. Park the vehicle on a level surface and apply the parking brake.
2. Turn the engine off.
3. Loosen the oil filter with an oil filter wrench. Remove the oil filter by turning it by hand.



CAUTION

Be careful not to burn yourself. The engine oil will be hot.

4. Wipe the engine oil filter mounting surface with a clean rag.

Be sure to remove any old rubber gasket remaining on the mounting surface of the engine.

5. Coat the rubber gasket on the new filter with clean engine oil.
6. Screw in the oil filter until a slight resistance is felt, then tighten additionally more than 2/3 turn.
7. Start the engine and check for leakage around the oil filter. Correct as required.

Check the oil level. Add engine oil as necessary.

DO-IT-YOURSELF

AUTOMATIC TRANSMISSION FLUID

WARNING

- *When the engine is running, keep hands, jewelry and clothing away from any moving parts such as fan drive belt.*
- *Automatic transmission fluid is poisonous and should be stored carefully in marked containers out of the reach of children.*

TEMPERATURE CONDITIONS FOR CHECKING

- The fluid level should be checked using the "HOT" range on the dipstick after the following conditions have been met:
 - The engine should be warmed up to

operating temperature.

- The vehicle should be driven at least 5 minutes.
- The automatic transmission fluid should be warmed to between 122 and 176°F (50 and 80°C).
- The fluid can be checked at fluid temperatures of 86 to 122°F (30 to 50°C) using the "COLD" range on the dipstick after the engine is warmed up and before driving. However, the fluid should be re-checked using the "HOT" range.

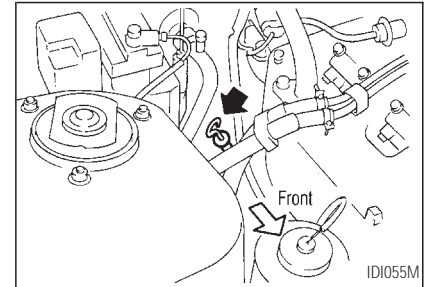

1. Park the vehicle on a level surface and set the parking brake.
2. Start the engine and then move the selector lever through each gear range ending in "P".

DO-IT-YOURSELF

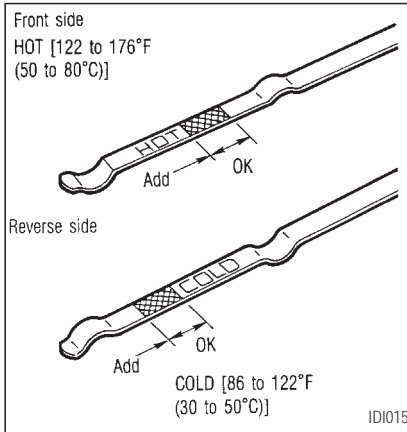

3. Check the fluid level with the engine idling.
4. Remove the dipstick and wipe it clean with lint-free paper.
5. Reinsert the dipstick into the charging pipe as far as it will go.
6. Remove the dipstick and note the reading.

If the level is at the low side of either range, add fluid to the charging pipe.



CAUTION

DO NOT OVERFILL.

USE Nissan Matic "D" (Continental U.S. and Alaska) or Genuine Nissan Automatic Transmission Fluid (Canada). Dexron® III/Mercon® or equivalent may also be used. Outside the continental United States and Alaska contact a Nissan dealership for more information regarding suitable fluids, including recommended brand(s) of Dexron® III/Mercon® or Dexron® IIE/Mercon® Automatic Transmission Fluid.

NOTE:

If the vehicle has been driven for a long

time at high speeds, or in city traffic in hot weather, or if it is being used to pull a trailer, an accurate fluid level cannot be read. You should wait until the fluid has cooled down (about 30 minutes).

DO-IT-YOURSELF

POWER STEERING FLUID

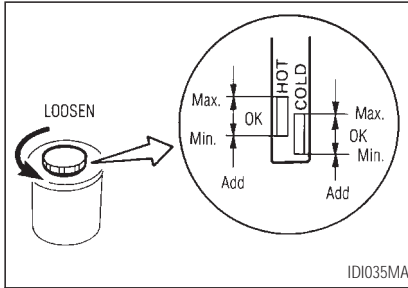

The fluid level should be checked using the "HOT" range on the dipstick at fluid temperature of 122 to 176°F (50 to 80°C) or using the "COLD" range on the dipstick at fluid temperature of 32 to 86°F (0 to 30°C).

⚠ CAUTION

- Do not overfill.
- Recommended fluid is type DEXRON™IIIE, DEXRON™III or equivalent.

BRAKE FLUID

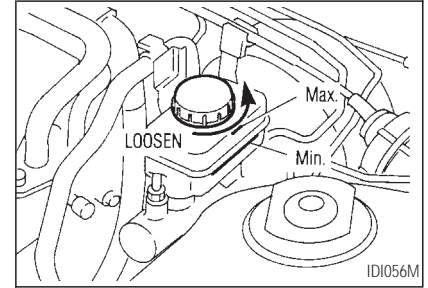

Check the fluid level in the reservoir. If the fluid is below the Min. line or the brake warning light comes on, add **DOT 3** fluid up to the Max. line. If fluid must be added frequently, the system should be checked by your INFINITI dealer.

DO-IT-YOURSELF



WARNING

Use only new fluid. Old, inferior, or contaminated fluid may damage the brake system. The use of improper fluids can damage the brake system and affect the vehicle's stopping ability.



CAUTION

Do not spill the fluid on painted surfaces. This will damage the paint. If fluid is spilled, wash with water.

WINDOW WASHER FLUID

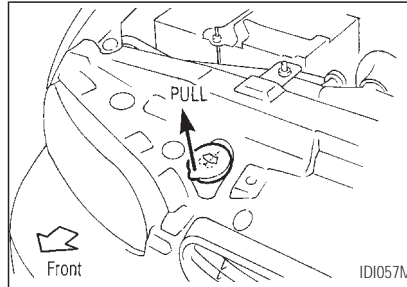

Add fluid when the low washer fluid warning light comes on. Add a washer solvent to the water for better cleaning. In the winter season, add a windshield washer anti-freeze. Follow the manufacturer's instructions for the mixture ratio.



CAUTION

Do not substitute engine anti-freeze coolant for window washer solution. This may result in damage to the paint.

BATTERY

- Keep the battery surface clean and dry. Any corrosion should be washed off with a solution of baking soda and water.
- Make certain the terminal connections are clean and securely tightened.
- If the vehicle is not to be used for 30 days or longer, disconnect the “—” negative battery terminal cable to prevent discharge.

DO-IT-YOURSELF



WARNING

- Do not expose the battery to flames or electrical sparks. Hydrogen gas generated by battery action is explosive. Do not allow battery fluid to contact your skin, eyes, fabrics, or painted surfaces. After touching a battery or battery cap, do not touch or rub your eyes. Thoroughly wash your hands. If the acid contacts your eyes, skin or clothing, immediately flush with water for at least 15 minutes and seek medical attention.
- When working on or near a battery, always wear suitable eye protection and remove all jewelry.

- Keep the battery out of the reach of children.

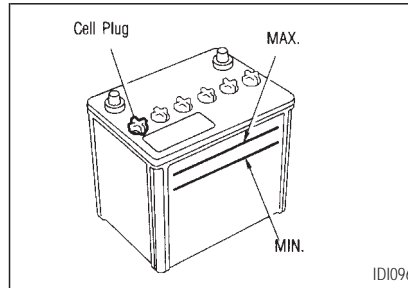

Check the fluid level in each cell (Remove the battery cover if it is necessary). It should be between the MAX. and MIN. lines.

If it is necessary to add fluid, add only distilled water to bring the level to the indicator in each filler opening. **Do not overfill.**

1. Remove the cell plugs.
2. Add distilled water up to the MAX. level.
3. Install the cell plugs.

JUMP STARTING

If jump starting is necessary, see the "In case of emergency" section. If the engine does not start by jump starting, the battery may have to be replaced. Contact your INFINITI dealer.

DRIVE BELTS

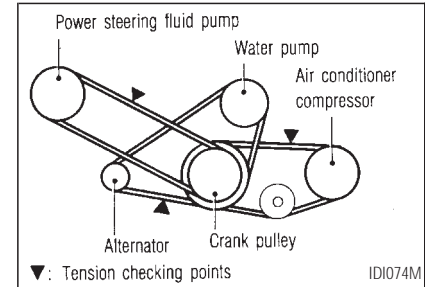

DO-IT-YOURSELF



WARNING

Be sure the ignition key is "OFF". The engine could rotate unexpectedly.

1. Visually inspect each belt for signs of unusual wear, cuts, fraying or looseness. If the belt is in poor condition or loose, have it replaced or adjusted by your INFINITI dealer.
2. Have the belts checked regularly for condition and tension in accordance with the maintenance schedule in this manual.

SPARK PLUG REPLACEMENT



WARNING

Be sure the engine and ignition switch are off and that the parking brake is engaged securely.



CAUTION

Be sure to use the correct socket to remove the plugs. An incorrect socket can cause damage.

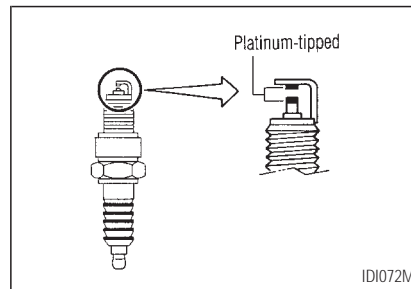

Platinum-tipped spark plugs

It is not necessary to replace the platinum-tipped spark plugs as frequently as the conventional type spark plugs since they will last much longer. Follow the maintenance schedule, but do not reuse them by cleaning or regapping.

If replacement is required, see your INFINITI dealer for servicing.

Always replace spark plugs with recommended or equivalent ones.

DO-IT-YOURSELF

AIR CLEANER

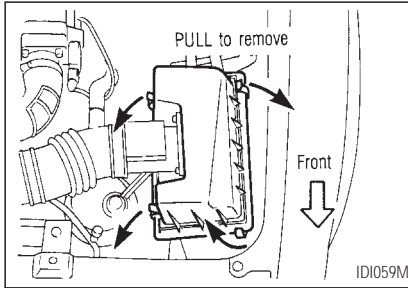

Viscous paper type

The filter element should not be cleaned and reused. Replace it according to the maintenance intervals shown in the "Maintenance" section. When replacing the filter, wipe the inside of the air cleaner housing and the cover with a damp cloth.

WARNING

Operating the engine with the air cleaner off can cause you or others to be burned. The air cleaner not only cleans the air, it stops flame if the engine backfires. If it is not there, and the engine backfires, you could be burned. Do not drive with it off, and be careful working on the engine with the air cleaner off.

WIPER BLADE

1) CLEANING

If your windshield is not clear after using the windshield washer, or if the wiper blade chatters when running, wax or other material may be on the blade or windshield.

Clean the outside of the windshield with a washer solution or a mild detergent. Your windshield is clean if beads do not form when rinsing with clear water.

Clean the blade by wiping it with a cloth soaked in a washer solution or a mild detergent. Then rinse the blade with clear water. If your windshield is still not clear after cleaning the blades and using the wiper, replace the blades.

DO-IT-YOURSELF

2) REPLACEMENT

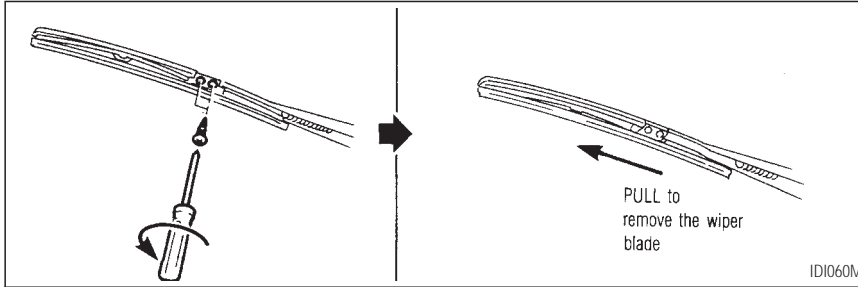

1. Pull the wiper arm.
2. Remove the screws, then remove the wiper blade.
3. Insert the new wiper blade onto the wiper arm and tighten the screws.



CAUTION

After wiper blade replacement, return the wiper arm to its original position. Otherwise it may be damaged when the engine hood is opened.

Make sure the wiper blade contacts

the glass, otherwise the arm may be damaged from wind pressure.

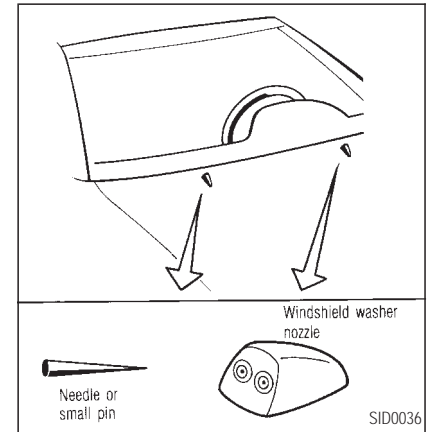

If you wax the surface of the hood, be careful not to let wax get into the washer nozzle. This may cause clog-

DO-IT-YOURSELF

ging or improper windshield washer operation. If wax gets into the nozzle, remove it with a needle or small pin.

PARKING BRAKE

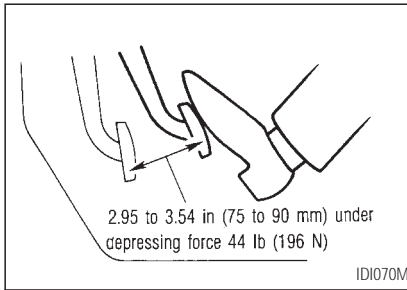

From the released position, depress the parking brake pedal slowly and firmly, and check the distance between the initial and final position of the pedal. If it is out of the range shown above, see your INFINITI dealer.

BRAKE PEDAL

With the engine running, check the distance between the upper surface of the pedal and the metal floor. If it is out of the range shown above, see your INFINITI dealer.

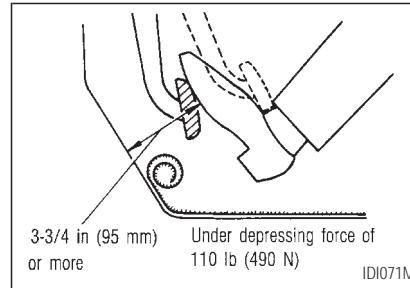

Self-adjusting brakes

Your vehicle is equipped with self-adjusting brakes.

The disc-type brakes self-adjust every time the brake pedal is applied.



WARNING

See your INFINITI dealer for a brake system check if the brake pedal height does not return to normal.

Brake pad wear indicators

The disc brake pads on your vehicle have audible wear indicators. When a brake pad requires replacement, it will make a high pitched scraping or screeching sound when the vehicle is in motion whether or not the brake pedal is depressed. Have the brakes checked as soon as possible if the wear indicator sound is heard.

Under some driving or climate conditions, occasional brake squeak, squeal or other noise may be heard. Occasional brake noise during light to moderate stops is normal and

DO-IT-YOURSELF

does not affect the function or performance of the brake system.

The rear drum brakes (if so equipped) do not have audible wear indicators. Should you ever hear an unusually loud noise from the rear drum brakes, have them inspected as soon as possible by your INFINITI dealer.

Proper brake inspection intervals should be followed. For more information regarding brake inspections, see the appropriate maintenance schedule information in the “Maintenance Schedule” section of this manual.

BRAKE BOOSTER

Check the brake booster function as follows:

1. With the engine off, press and release the brake pedal several times. When brake pedal movement (distance of travel) remains the same from one pedal application to the next, continue on to the next step.

2. While depressing the brake pedal, start the engine. The pedal height should drop a little.
3. With the brake pedal depressed, stop the engine. Keeping the pedal depressed for about 30 seconds, the pedal height should not change.
4. Run the engine for one minute without depressing the brake pedal, then turn it off. Depress the brake pedal several times. The pedal travel distance will decrease gradually with each depression as the vacuum is released from the booster.

If the brakes do not operate properly, see your INFINITI dealer.

FUSES



CAUTION

Never use a fuse of higher amperage rating than that specified on the fuse box cover. This could damage the electrical system or cause a fire.

Engine compartment

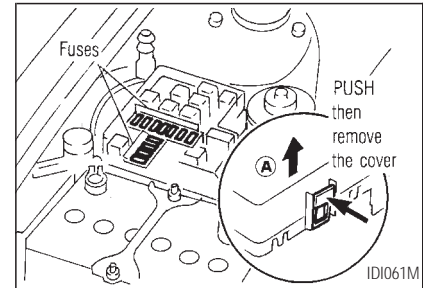

If any electrical equipment does not operate,

DO-IT-YOURSELF

check for an open fuse.

1. Be sure the ignition key and the headlight switch are "OFF".
2. Open the engine hood.
3. Remove the fuse box cover (A).
4. Remove the fuse with the fuse puller.
5. If the fuse is open, replace it with a new fuse.
6. If a new fuse opens again, have the electrical system checked and repaired by your INFINITI dealer.

Passenger compartment

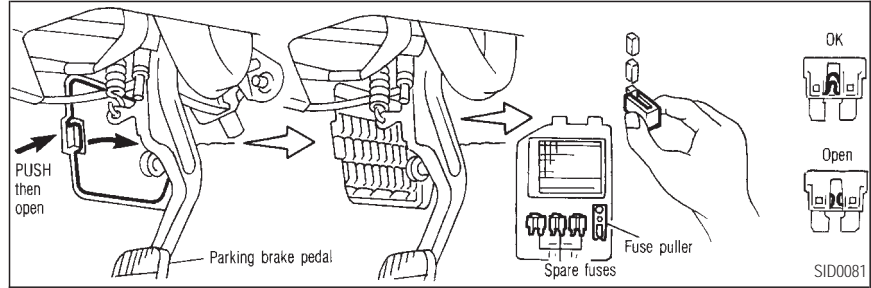

If any electrical equipment does not operate, check for a burned-out fuse.

1. Be sure the ignition key and the headlight switch are "OFF".
2. Open the fuse box cover.
3. Remove the fuse with the fuse puller.
4. If the fuse is open, replace it with a new fuse.

5. If a new fuse opens again, have the electrical system checked and repaired by your INFINITI dealer.

DO-IT-YOURSELF

FUSIBLE LINKS

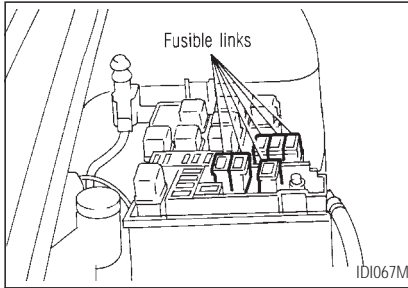

If any electrical equipment does not operate and fuses are in good condition, check the fusible links. If any of these fusible links are melted, replace only with genuine parts. See your INFINITI dealer.

LIGHT BULBS

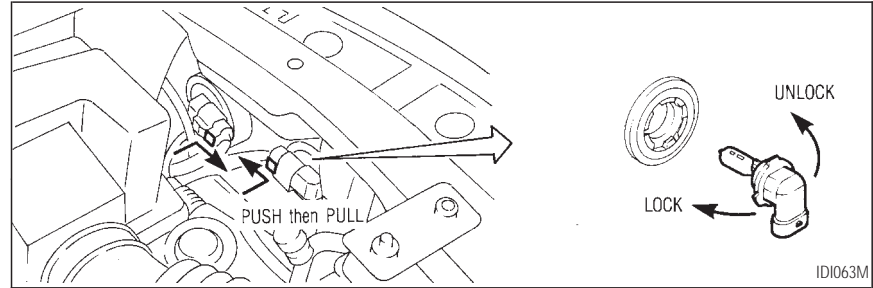

HEADLIGHTS

The headlight is a semi-sealed beam type which uses a replaceable headlight (halogen) bulb. A bulb can be replaced from inside the engine compartment without removing the headlight assembly.



CAUTION

High pressure halogen gas is sealed inside the bulb. The bulb may break if the glass envelope is scratched or the bulb is dropped.

Hold the plastic base when handling

DO-IT-YOURSELF

the bulb. Never touch the glass envelope.

Removing the headlight bulb

1. Disconnect the negative battery cable.
2. Remove the cover.
3. Disconnect the electrical connector by pushing the knob and pulling connector base sideward from the rear end of the bulb.
4. Turn the plastic base counterclockwise until it is free from the headlight reflector, then remove it.
5. Remove the headlight bulb. Do not shake or rotate the bulb when removing it.

Replacing the headlight bulb

1. Insert the bulb into the headlight reflector with the plastic base facing downward and

turn it clockwise until it stops.

2. Push the electrical connector into the bulb plastic base until it snaps and stops.
3. Connect the negative battery cable.



CAUTION

DO NOT TOUCH THE BULB.

- ***Use the same number and wattage as originally installed:***

	Inside (High beam)	Outside (Low beam)
Wattage (W)	65	55
Bulb no.	9005 (HB3)	9006 (HB4)

- ***Aiming is not necessary after replacing the bulb. When aiming adjustment is necessary, contact your INFINITI dealer.***
- ***Do not leave the bulb out of the headlight reflector for a long period of time as dust, moisture, and smoke may enter the headlight body and affect the performance of the headlight.***

DO-IT-YOURSELF

Adjusting the headlight aim.

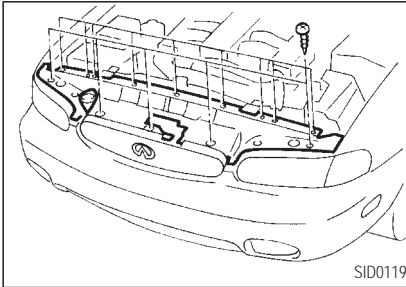

Before adjusting the headlights, make sure that all of the tires are properly inflated, the vehicle is on level ground and there is no excess weight in the vehicle that would effect the level of the vehicle.

First, open the hood. Then remove the air guide.

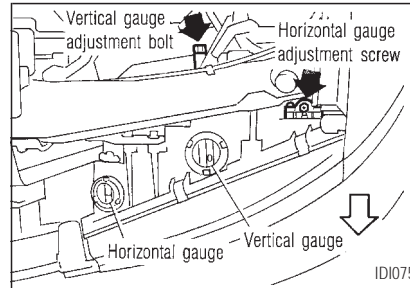

You will see two gauges on the headlight. The gauge on the side further away from the engine is the vertical gauge. The gauge that is closer to the engine is the horizontal gauge.

The vertical gauge adjustment bolt is behind the headlight. The air bubble in this gauge should be centered on the "O" mark. This can be done with an 8 millimeter wrench. Turn the adjustment bolt clockwise and the headlight beam will raise, moving the air bubble in the gauge forward. Turn the adjustment bolt counterclockwise and the headlight beam will

lower, moving the air bubble backward.

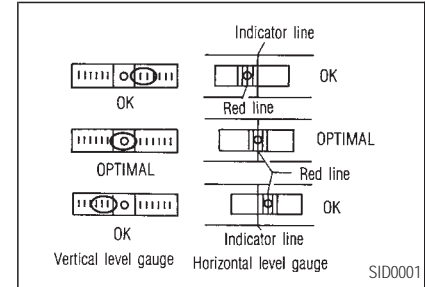

The horizontal gauge adjustment screw is above the headlight. The inner red line should align with the "O" mark on the indicator.

To adjust the horizontal level of the headlight, turn the adjustment screw with a Phillips screwdriver. Turn the screw clockwise to turn the headlight beam left, and turn it counterclockwise to turn the headlight beam right.

DO-IT-YOURSELF

OTHER LIGHTS

Item	Wattage (W)	Bulb No.
Parking light	5	
Front turn signal light	27	1156 NA
Front side marker light	3.8	194
Rear combination light		
stop/tail	27/8	1157
turn signal	27	1156
Back-up light	18	921
Rear side marker light	3.8	194
License plate light	5	0116
High-mounted stop light	13	922
Interior light	10	—
Personal light	8	—
Vanity mirror light	1.8	—
Step light	3.4	158
Foot light	3.4	158
Trunk light	3.4	158

DO-IT-YOURSELF

LIGHT LOCATION

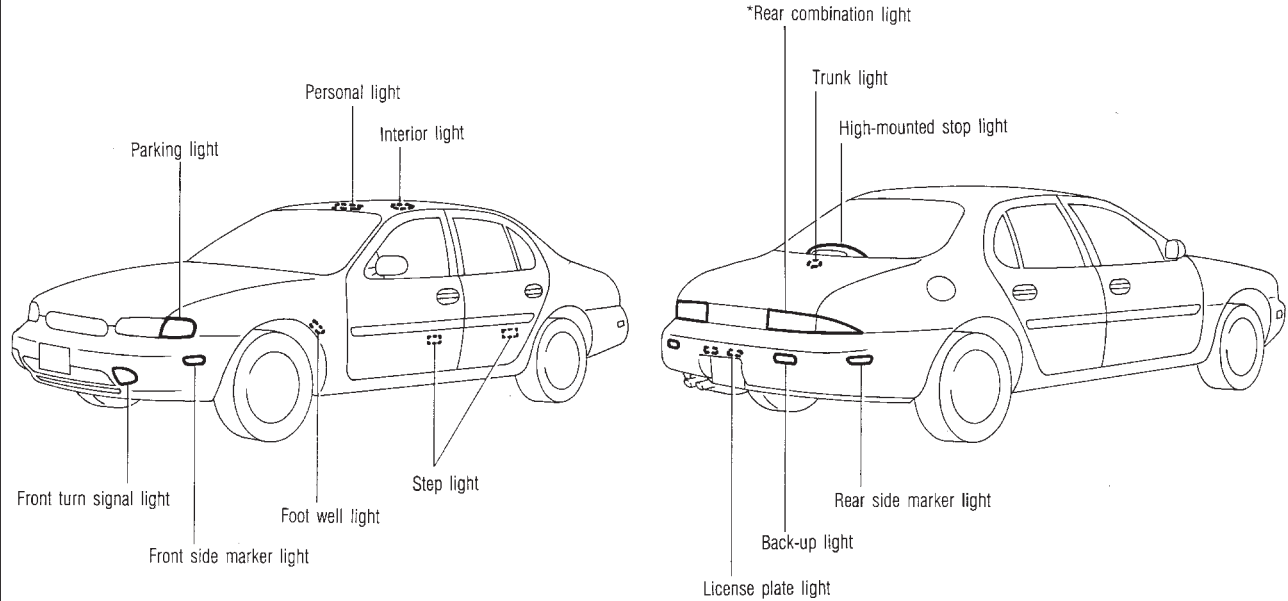

*When replacing any of the rear combination bulbs, see your INFINITI dealer.

ID1064M

DO-IT-YOURSELF

Replacement procedures

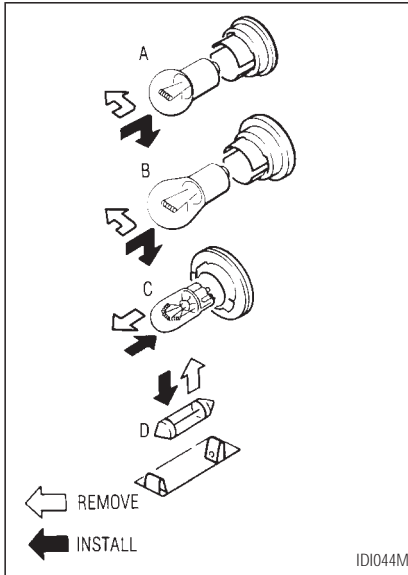

All other lights are either type A, B or C. When

replacing a bulb, first remove the lens and/or cover.

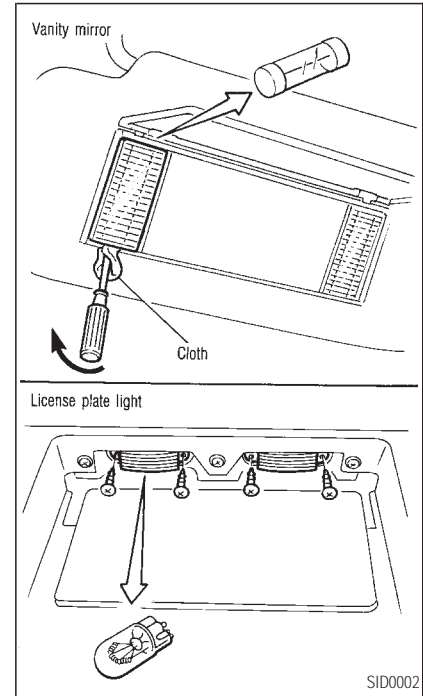

DO-IT-YOURSELF

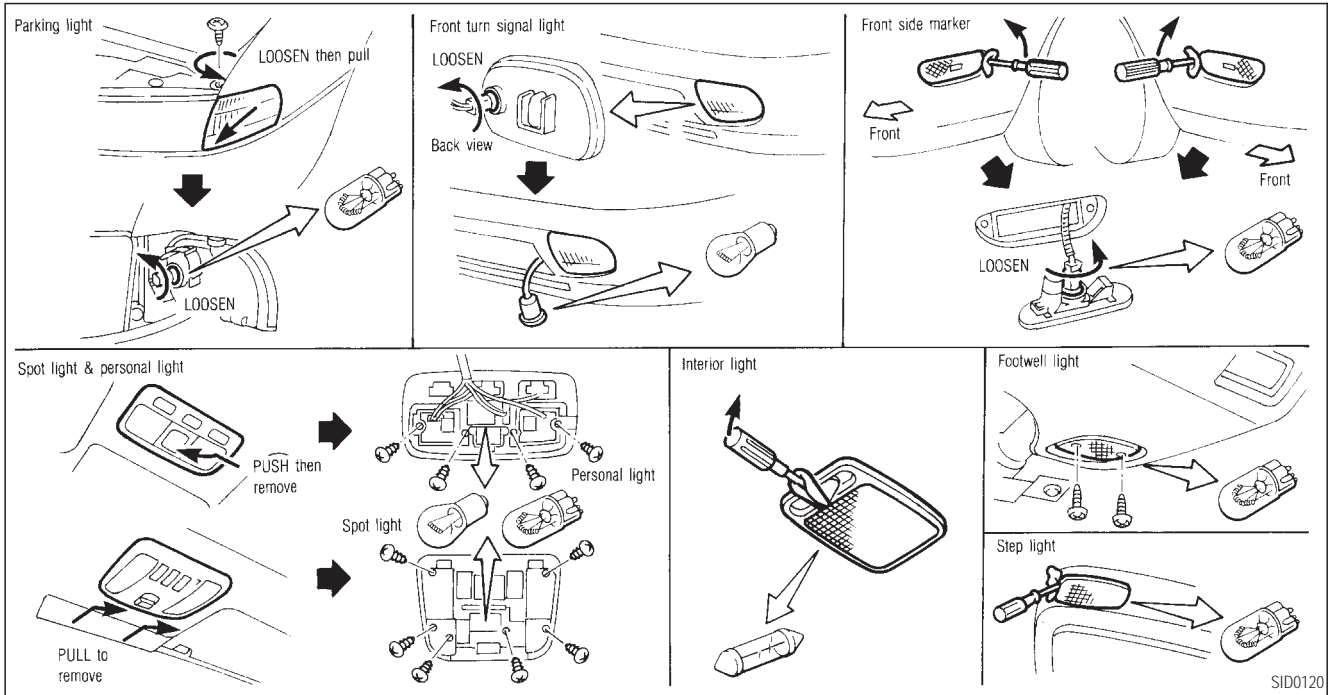

DO-IT-YOURSELF

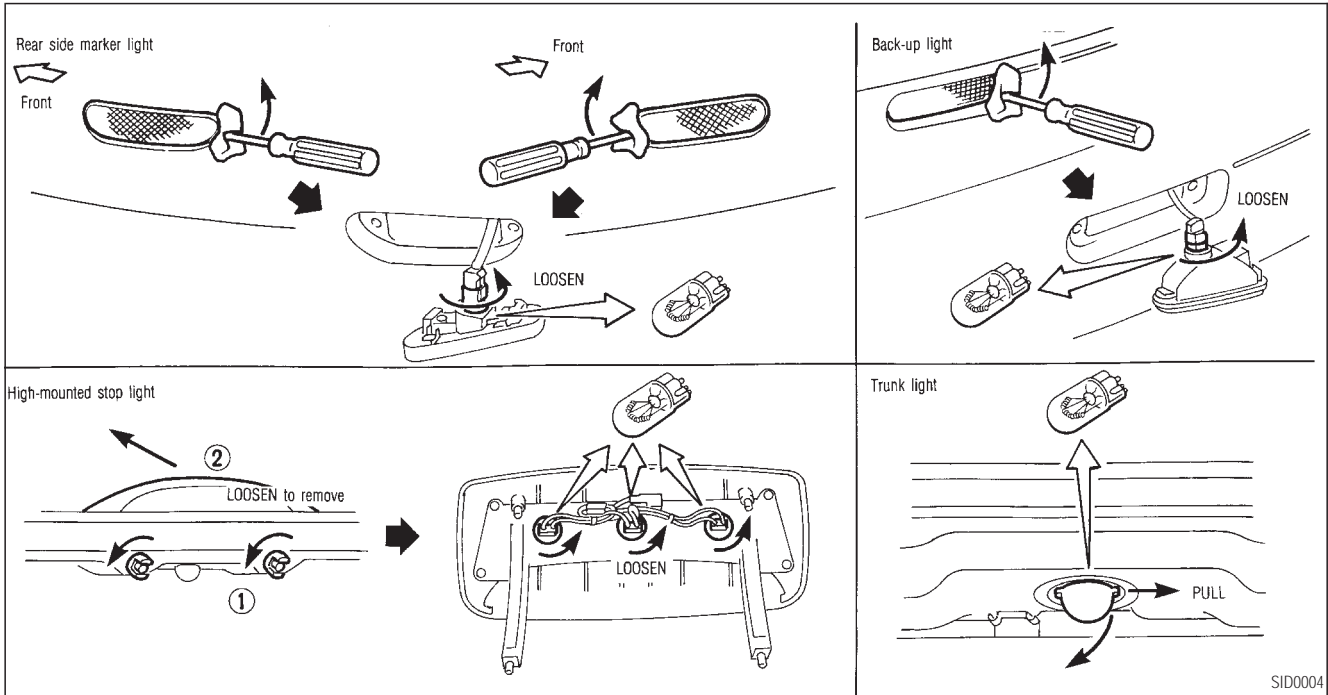

DO-IT-YOURSELF

WHEELS AND TIRES

If you have a flat tire, see “In case of emergency” section.

Maximum inflation pressure

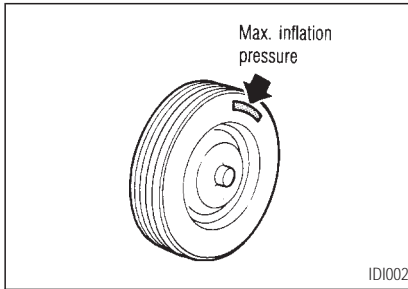

Do not exceed the maximum inflation pressures shown on the side wall of the tire.

Tire inflation pressure

Periodically check the tire pressure (including spare). Incorrect tire pressure may adversely affect tire life and vehicle handling. Tire pres-

sure should be checked when the tires are COLD. Tires are considered COLD after the vehicle has been parked for three or more hours, or driven less than 1 mile (1.6 km). COLD tire pressures are shown on the tire placard affixed to the center console lid.

WARNING

- *The vehicle weight capacity is indicated on the tire placard. Do not load your vehicle beyond this capacity. Overloading your vehicle may result in reduced tire life, unsafe operating conditions due to premature tire failure, or unfavorable handling characteristics and could also lead to a serious accident. Loading beyond the specified capacity may also result in failure of other vehicle*

components.

- *Before taking a long trip, or whenever you have loaded your vehicle heavily, use a tire pressure gauge to ensure that the tire pressure is at the specified level.*
- *Do not drive your vehicle over 85 MPH (140 km/h) unless it is equipped with high speed capability tires. Driving faster than 85 MPH (140 km/h) may result in tire failure, loss of control and possible injury.*

DO-IT-YOURSELF

Types of tires



CAUTION

When changing or replacing tires, be sure all four tires are of the same type (i.e., Summer, All Season or Snow) and construction. Your INFINITI dealer may be able to help you with information about tire type, size, speed rating and availability. Replacement tires may have a lower speed rating than the factory equipped tires, and may not match the potential maximum vehicle speed. Never exceed the maximum speed rating of the tire.

All season tires

INFINITI specifies All Season tires on some models to provide good performance for use all year around, including snowy and icy road conditions. All Season Tires are identified by “ALL SEASON” and/or “M&S” on the tire sidewall. Snow tires have better snow traction than All Season tires and may be more appropriate in some areas.

Summer tires

INFINITI specifies summer tires on some models to provide superior performance on dry roads. Summer tire performance in snow and ice will be substantially reduced. Summer tires do not have the tire traction rating “M&S” on the tire sidewall.

If you plan to operate your vehicle in snowy or icy conditions, INFINITI recommends the use of “SNOW” or “ALL SEASON” tires on all four wheels.

Snow tires

If snow tires are needed, it is necessary to select tires equivalent in size and load rating to the original equipment tires. If you do not, it can adversely affect the safety and handling of your vehicle.

Generally, snow tires will have lower speed ratings than factory equipped tires and may not match the potential maximum vehicle speed. Never exceed the maximum speed rating of the tire.

For additional traction on icy roads, studded tires may be used. However, some provinces and states prohibit their use. Check local, state and provincial laws before installing studded tires. Skid and traction capabilities of studded snow tires, on wet or dry surfaces, may be poorer than that of non-studded snow tires.

Tire chains

Use of tire chains may be prohibited accord-

DO-IT-YOURSELF

ing to location. Check the local laws before installing tire chains. When installing tire chains, make sure they are of proper size for the tires on your vehicle and are installed according to the chain manufacturer's suggestions. **Use only SAE Class "S" chains.** Other types may damage your vehicle. Use chain tensioners when recommended by the tire chain manufacturer to ensure a tight fit. Loose end links of the tire chain must be secured or removed to prevent the possibility of whipping action damage to the fenders or underbody. If possible, avoid fully loading your vehicle when using tire chains. In addition, drive at a reduced speed. Otherwise, your vehicle may be damaged and/or vehicle handling and performance may be adversely affected.

Never install tire chains on T-type spare tires. Do not use tire chains on dry roads.

Tire rotation

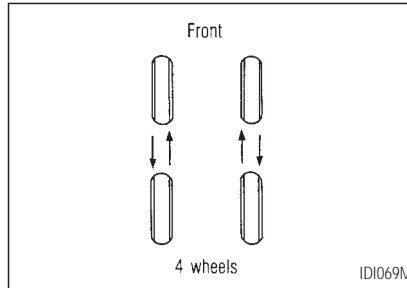

INFINITI recommends that tires be rotated every 7,500 miles (12,000 km).

Wheel nut tightening torque:
72 to 87 ft-lb
(98 to 118 N·m)

See "Flat tire" in the "In case of emergency" section for tire replacing procedures.



WARNING

- After rotating the tires, adjust the tire pressure.
- Retighten the wheel nuts any time after the aluminum wheels have been run for the first 600 miles (1,000 km) (also in cases of a flat tire, etc.).
- Do not include the T-type spare tire or any other small size spare tire in the tire rotation.

DO-IT-YOURSELF

Tire wear and damage

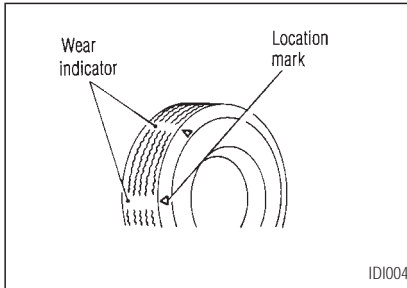

WARNING

- *Tires should be inspected periodically for wear, cracking, bulging, or objects caught in the tread. If excessive wear, cracks, bulging, or deep cuts are found, the tire should be replaced.*

- *The original tires have a built-in tread wear indicator. When the wear indicator is visible, the tire should be replaced.*
- *Improper service for a T-type spare tire may result in serious personal injury. If it is necessary to repair the T-type spare tire, contact your INFINITI dealer.*

Changing tires and wheels

When replacing a tire, use the same size and load carrying capacity as the original equipment tires. Recommended types and sizes are shown in "Wheels & tires" in the "Technical information" section.



WARNING

- *The use of tires other than those recommended or the mixed use of tires of different brands, construction (bias, bias-belted or radial), or tread patterns can adversely affect the ride, braking, handling, ground clearance, body-to-tire clearance, snow chain clearance, speedometer calibration, headlight aim and bumper height. Some of these effects may lead to accidents and could result in serious personal injury.*
- *If the wheels are changed for any reason, always replace with wheels which have the same offset dimension. Wheels of a dif-*

DO-IT-YOURSELF

ferent offset could cause early tire wear, possibly degraded vehicle handling characteristics and/or interference with the brake discs/drums. Such interference can lead to decreased braking efficiency and/or early brake pad/shoe wear.

- *Do not install a deformed wheel or tire even if it has been repaired. Such wheels or tires could have structural damage and could fail without warning.*

Wheel balance

Unbalanced wheels may affect vehicle handling and tire life. Even with regular use, wheels can get out of balance. Therefore, they should be balanced as required.

Wheel balance service should be performed with the wheels off the vehicle. Spin balancing the driving wheels on the vehicle could lead to transmission damage.

Care of wheels

- Wash the wheels when washing the vehicle to maintain their appearance.
- Clean the inner side of the wheels when the wheel is changed or the underside of the vehicle is washed.
- Do not use abrasive cleaners when washing the wheels.
- Inspect wheel rims regularly for dents or corrosion. Such damage may cause loss of pressure or poor seal at the tire bead.
- INFINITI recommends that the road wheels be waxed to protect against road salt in areas where it is used during winter.

Spare tire (T-type spare tire)

Observe the following precautions if the T-type spare tire must be used, otherwise your vehicle could be damaged or involved in an accident.



CAUTION

- *The T-type spare tire should be used only for emergency. It should be replaced by the standard tire at the first opportunity.*
- *Drive carefully while the T-type spare tire is installed. Avoid sharp turns and abrupt braking while driving.*
- *Periodically check tire inflation pressure, and always keep it at 60 psi (420 kPa, 4.2 bar).*

DO-IT-YOURSELF

- *Do not drive your vehicle a speeds faster than 50 MPH (80 km/h).*
 - *Do not use tire chains on a T-type spare tire. Tire chains will not fit properly on the T-type spare tire and may cause damage to the vehicle.*
 - *When driving on roads covered with snow or ice, the T-type spare tire should be used on the front and original tire used on the rear wheels (drive wheels). Use tire chains only on the rear two original tires.*
 - *Tire tread of the T-type spare tire will wear at a faster rate than the original tire. Replace the T-type spare tire as soon as the tread wear indicators appear.*
- *Because the T-type spare tire is smaller than the original tire, ground clearance is reduced. To avoid damage to the vehicle do not drive over obstacles. Also do not drive the vehicle through an automatic car wash since it may get caught.*
 - *Do not use the T-type spare tire on other vehicles.*
 - *Do not use more than one T-type spare tire at the same time.*
 - *Do not tow a trailer while the T-type spare tire is installed.*

8 MAINTENANCE

General maintenance	8-2
Periodic maintenance	8-5

MAINTENANCE

Your new INFINITI has been designed to have minimum maintenance requirements with longer service intervals to save you both time and money. However, some day-to-day and regular maintenance is essential to maintain your INFINITI's good mechanical condition, as well as its emission and engine performance.

It is the owner's responsibility to make sure that the specified maintenance, as well as general maintenance, is performed.

As the vehicle owner, you are the only one who can ensure that your vehicle receives the proper maintenance care. You are a vital link in the maintenance chain.

General maintenance

General maintenance includes those items which should be checked during normal day-to-day operation of the vehicle. They are essential if your vehicle is to continue to operate properly. It is your responsibility to

perform these procedures regularly as prescribed.

These checks or inspections can be done by yourself, a qualified technician or, if you prefer, your INFINITI dealer.

Periodic maintenance

The maintenance items listed in this part are required to be serviced at regular intervals.

However, under severe driving conditions, additional or more frequent maintenance will be required.

Where to go for service

If maintenance service is required or your vehicle appears to malfunction, have the systems checked and serviced by an authorized INFINITI dealer.

INFINITI technicians are well-trained specialists and are kept up to date with the latest service information through technical bulletins, service tips, and in-dealership informa-

tion systems. They are completely qualified to work on INFINITI vehicles **before** work begins.

You can be confident that your INFINITI dealer's service department performs the best job to meet the maintenance requirements on your vehicle — in a reliable and economic way.

GENERAL MAINTENANCE

During the normal day-to-day operation of the vehicle, general maintenance should be performed regularly as prescribed in this section. If you detect any unusual sounds, vibrations or smell, be sure to check for the cause or have your INFINITI dealer do it promptly. In addition, you should notify your INFINITI dealer if you think that repairs are required.

When performing any checks or maintenance work, closely observe the precautions in the "Do-it-yourself" section.

MAINTENANCE

Additional information on the following items with “*” is found in the “Do-it-yourself” section.

OUTSIDE THE VEHICLE

The maintenance items listed here should be performed from time to time, unless otherwise specified.

Tires* Check the pressure with a gauge periodically when at a service station, including the spare, and adjust to the specified pressure if necessary. Check carefully for damage, cuts or excessive wear.

Wheel nuts* When checking the tires, make sure no nuts are missing, and check for any loose nuts. Tighten if necessary.

Tire rotation* Tires should be rotated every 7,500 miles (12,000 km).

Wheel alignment and balance If the vehicle pulls to either side while driving on a straight and level road, or if you detect uneven

or abnormal tire wear, there may be a need for wheel alignment.

If the steering wheel or seat vibrates at normal highway speeds, wheel balancing may be needed.

Windshield wiper blades* Check for cracks or wear if they do not wipe properly.

Doors and engine hood Check that all doors and the engine hood, operate properly. Also ensure that all latches lock securely. Lubricate hinges and latches if necessary. Make sure that the secondary latch keeps the hood from opening when the primary latch is released.

When driving in areas using road salt or other corrosive materials, check lubrication frequently.

INSIDE THE VEHICLE

The maintenance items listed here should be checked on a regular basis, such as when

performing periodic maintenance, cleaning the vehicle, etc.

Lights* Make sure that the headlights, stop lights, tail lights, turn signal lights, and other lights are all operating properly and installed securely. Also check headlight aim.

Warning lights and buzzers/chimes Make sure that all warning lights and buzzers/chimes are operating properly.

Windshield wiper and washer* Check that the wipers and washer operate properly and that the wipers do not streak.

Windshield defroster Check that the air comes out of the defroster outlets properly and in sufficient quantity when operating the heater or air conditioner.

Steering wheel Check for changes in the steering conditions, such as excessive free play, hard steering or strange noises.

Seats Check seat position controls such as

MAINTENANCE

seat adjusters, seatback recliner, etc. to ensure they operate smoothly and that all latches lock securely in every position. Check that the head restraints move up and down smoothly and that the locks (if so equipped) hold securely in all latched positions.

Seat belts Check that all parts of the seat belt system (e.g. buckles, anchors, adjusters and retractors) operate properly and smoothly, and are installed securely. Check the belt webbing for cuts, fraying, wear or damage.

Accelerator pedal Check the pedal for smooth operation and make sure the pedal does not catch or require uneven effort. Keep the floor mats away from the pedal.

Brakes Check that the brakes do not pull the vehicle to one side when applied.

Brake pedal* Check the pedal for smooth operation and make sure it has the proper distance under it when depressed fully. Check the brake booster function. Be sure to keep the

floor mats away from the pedal.

Parking brake* Check that the lever has the proper travel and confirm that your vehicle is held securely on a fairly steep hill with only the parking brake applied.

Automatic transmission “Park” mechanism On a fairly steep hill check that your vehicle is held securely with the selector lever in the “P” position without applying any brakes.

UNDER THE HOOD AND VEHICLE

The maintenance items listed here should be checked periodically e.g. each time you check the engine oil or refuel.

Windshield washer fluid* Check that there is adequate fluid in the tank.

Engine coolant level* Check the coolant level when the engine is cold.

Radiator and hoses Check the front of the

radiator and clean off any dirt, insects, leaves, etc., that may have accumulated. Make sure the hoses have no cracks, deformation, deterioration or loose connections.

Brake fluid level* Make sure that the brake fluid level is between the “MAX” and “MIN” lines on the reservoir.

Battery* Check the fluid level in each cell. It should be between the “MAX” and “MIN” lines.

Engine drive belts* Make sure that no belt is frayed, worn, cracked or oily.

Engine oil level* Check the level after parking the vehicle on a level spot and turning off the engine. (Be sure to wait a few minutes to allow the oil to drain back into the sump.)

Power steering fluid level* and lines Check the level when the fluid is cold and the engine is turned off. Check the lines for proper attachment, leaks, cracks, etc.

MAINTENANCE

Automatic transmission fluid level*

Check the level after putting the selector lever in "P" with the engine idling.

Exhaust system Make sure there are no loose supports, cracks or holes. If the sound of the exhaust seems unusual or there is a smell of exhaust fumes, immediately locate the trouble and correct it. (See the carbon monoxide warning in the "Starting and driving" section.)

Underbody The underbody is frequently exposed to corrosive substances such as those used on icy roads or to control dust. It is very important to remove these substances, otherwise rust will form on the floor pan, frame, fuel lines and around the exhaust system. At the end of winter, the underbody should be thoroughly flushed with plain water, being careful to clean those areas where mud and dirt may accumulate. See the "Appearance and care" section for additional information.

Fluid leaks Check under the vehicle for fuel, oil, water or other fluid leaks after the vehicle has been parked for a while. Water dripping from the air conditioner after use is normal. If you should notice any leaks or if gasoline fumes are evident, check for the cause and have it corrected immediately.

PERIODIC MAINTENANCE

To ensure smooth, trouble-free, safe and economical driving, INFINITI provides two different maintenance schedules that may be used, depending upon the conditions in which you usually drive. These schedules contain both distance and time intervals, up to 60,000 miles (96,000 km)/48 months. For most people, the odometer reading will indicate when service is needed. However, if you drive very little, your vehicle should be serviced at the regular time intervals shown in the schedule. **After 60,000 miles (96,000 km) or 48 months, continue periodic maintenance**

at the same mileage/time intervals.

SCHEDULE 1

Follow Periodic Maintenance Schedule 1 if your driving habits frequently include one or more of the following driving conditions:

- **Repeated short trips of less than 5 miles (8 km).**
- **Repeated short trips of less than 10 miles (16 km) with outside temperatures remaining below freezing.**
- **Operating in hot weather in stop-and-go "rush hour" traffic.**
- **Extensive idling and/or low speed driving for long distances, such as police, taxi or door-to-door delivery use.**
- **Driving in dusty conditions.**

MAINTENANCE

- Driving on rough, muddy, or salt spread roads.
- Towing a trailer, using a camper or a car-top carrier.

SCHEDULE 2

Follow Periodic Maintenance Schedule 2 if none of the driving conditions shown in Schedule 1 apply to your driving habits.

MAINTENANCE

SCHEDULE 1

Abbreviations: R = Replace I = Inspect. Correct or replace if necessary.

[]: Perform service at the mileage intervals only

MAINTENANCE OPERATION	MAINTENANCE INTERVAL																	
	Miles x 1,000 (km x 1,000)	3.75 (6)	7.5 (12)	11.25 (18)	15 (24)	18.75 (30)	22.5 (36)	26.25 (42)	30 (48)	33.75 (54)	37.5 (60)	41.25 (66)	45 (72)	48.75 (78)	52.5 (84)	56.25 (90)	60 (96)	
	Months	3	6	9	12	15	18	21	24	27	30	33	36	39	42	45	48	
EMISSION CONTROL SYSTEM MAINTENANCE																		
Service "A"																		
Engine oil		R	R	R	R	R	R	R	R	R	R	R	R	R	R	R	R	
Engine oil filter (Use Part No. 15208-60U00 or equivalent)		R	R	R	R	R	R	R	R	R	R	R	R	R	R	R	R	
Service "E"																		
Air cleaner filter	See NOTE (1)									[R]							[R]	
Service "F"																		
Vapor lines										I*							I*	
Fuel lines										I*							I*	
Fuel filter	See NOTE (2)*																	
Service "G"																		
Drive belts	See NOTE (3)																	I*
Service "J"																		
Engine coolant	See NOTE (4)																	R*
Service "H"																		
Spark plugs (PLATINUM-TIPPED type)																		[R]
Timing belt																		Replace every 105,000 miles (168,000 km)

- NOTE:
- (1) If operating mainly in dusty conditions, more frequent maintenance may be required.
 - (2) If vehicle is operated under extremely adverse weather conditions or in areas where ambient temperatures are either extremely low or extremely high, the filters might become clogged. In such an event, replace them immediately.
 - (3) After 60,000 miles (96,000 km) or 48 months, inspect every 15,000 miles (24,000 km) or 12 months.
 - (4) After 60,000 miles (96,000 km) or 48 months, replace every 30,000 miles (48,000 km) or 24 months.
- * Maintenance items and intervals with "*" are recommended by INFINITI for reliable vehicle operation. The owner need not perform such maintenance in order to maintain the emission warranty or manufacturer recall liability. Other maintenance items and intervals are required.

MAINTENANCE

SCHEDULE 1

Abbreviations: R = Replace I = Inspect. Correct or replace if necessary.

[]: Perform service at the mileage intervals only

MAINTENANCE OPERATION	MAINTENANCE INTERVAL																	
	Miles x 1,000 (km x 1,000)	3.75 (6)	7.5 (12)	11.25 (18)	15 (24)	18.75 (30)	22.5 (36)	26.25 (42)	30 (48)	33.75 (54)	37.5 (60)	41.25 (66)	45 (72)	48.75 (78)	52.5 (84)	56.25 (90)	60 (96)	
Perform at number of miles, kilometers or months, whichever comes first.	Months	3	6	9	12	15	18	21	24	27	30	33	36	39	42	45	48	

CHASSIS AND BODY MAINTENANCE

Service "B"																	
Brake pads & discs			I		I		I		I		I		I		I		I
Steering gear & linkage, axle & suspension parts			I		I		I		I		I		I		I		I
Steering linkage ball joints & front suspension ball joints			I		I		I		I		I		I		I		I
Exhaust system			I		I		I		I		I		I		I		I
Service "D"																	
Brake lines & cables					I				I				I				I
Automatic transmission fluid & differential gear oil	See NOTE (1)				I				I				I				I
Supplemental air bag system	See NOTE (2)																

NOTE: (1) If towing a trailer, using a camper or a car-top carrier, or driving on rough or muddy roads, change (not just inspect) oil at every 30,000 miles (48,000 km) or 24 months.
 (2) Inspect the supplemental air bag system 10 years after the date of manufacture noted on the F.M.V.S.S. certification label.

MAINTENANCE

SCHEDULE 2

Abbreviations: R = Replace I = Inspect. Correct or replace if necessary.

[]: Perform service at the mileage intervals only

MAINTENANCE OPERATION	MAINTENANCE INTERVAL									
	Miles x 1,000 (km x 1,000)	7.5 (12)	15 (24)	22.5 (36)	30 (48)	37.5 (60)	45 (72)	52.5 (84)	60 (96)	
	Months	6	12	18	24	30	36	42	48	
EMISSION CONTROL SYSTEM MAINTENANCE										
Service "B"										
Engine oil			R	R	R	R	R	R	R	R
Engine oil filter (Use Part No. 15208-60U00 or equivalent)			R	R	R	R	R	R	R	R
Service "E"										
Air cleaner filter						[R]				[R]
Service "F"										
Vapor lines						I*				I*
Fuel lines						I*				I*
Fuel filter	See NOTE (1)*									
Service "G"										
Drive belts	See NOTE (2)									I*
Service "J"										
Engine coolant	See NOTE (3)									R*
Service "H"										
Spark plugs (PLATINUM-TIPPED Type)										[R]
Timing belt										Replace every 105,000 miles (168,000 km)

NOTE: (1) If vehicle is operated under extremely adverse weather conditions or in areas where ambient temperatures are either extremely low or extremely high, the filters might become clogged. In such an event, replace them immediately.

(2) After 60,000 miles (96,000 km) or 48 months, inspect every 15,000 miles (24,000 km) or 12 months.

(3) After 60,000 miles (96,000 km) or 48 months, replace every 30,000 miles (48,000 km) or 24 months.

* Maintenance items and intervals with "*" are recommended by INFINITI for reliable vehicle operation. The owner need not perform such maintenance in order to maintain the emission warranty or manufacturer recall liability. Other maintenance items and intervals are required.

MAINTENANCE

SCHEDULE 2

Abbreviations: R = Replace I = Inspect. Correct or replace if necessary.

[]: Perform service at the mileage intervals only

MAINTENANCE OPERATION	MAINTENANCE INTERVAL									
	Miles x 1,000 (km x 1,000)	7.5 (12)	15 (24)	22.5 (36)	30 (48)	37.5 (60)	45 (72)	52.5 (84)	60 (96)	
Perform at number of miles, kilometers or months, whichever comes first.	Months	6	12	18	24	30	36	42	48	
CHASSIS AND BODY MAINTENANCE										
Service "D"										
Brake lines & cables			I		I		I		I	
Brake pads & discs			I		I		I		I	
Automatic transmission fluid & differential gear oil			I		I		I		I	
Service "F"										
Steering gear linkage axle & suspension parts						I				I
Exhaust system						I				I
Supplemental air bag system	See NOTE (1)									

NOTE: (1) Inspect the supplemental air bag system 10 years after the date of manufacture noted on the F.M.V.S.S. certification label.

MAINTENANCE

EXPLANATION OF MAINTENANCE ITEMS

Additional information on the following items with “*” is found in the “Do-it-yourself” section.

Emission control system maintenance

Drive belts* Check drive belts for wear, fraying or cracking and also for proper tension. Replace the drive belts if found damaged.

Air cleaner filter Under normal driving conditions, the air cleaner filter should be replaced in accordance with the maintenance schedule. However, driving the vehicle in dusty areas may cause more rapid clogging of the element. Consequently, the element may have to be replaced more frequently.

Vapor lines Check vapor lines and connections for failure or looseness. If leaks are found, replace them.

Fuel lines Check the fuel hoses, piping and connections for leaks, looseness or deterioration. Replace any parts if they are damaged.

Fuel filter If the vehicle is operated under extremely adverse weather conditions or in areas where ambient temperatures are either extremely low or extremely high, the filter might become clogged. In such an event, replace the filter immediately.

Engine coolant* Drain and flush the cooling system.

Engine oil & oil filter* Under normal driving conditions, the engine oil and oil filter should be replaced in accordance with the maintenance schedule. However, under severe driving conditions, they may have to be replaced more frequently.

Spark plugs* Replace with new plugs having the correct heat range.

Timing belt Replace the timing belt which drives the camshaft.

Chassis and body maintenance

Brake lines & cables Check the brake lines and hoses (including brake booster vacuum hoses, connections & check valve) and parking brake cables for proper attachment, leaks, cracks, chafing, abrasion, deterioration, etc.

Brake pads & discs Check these and the other neighboring brake components for wear, deterioration and leaks. Under severe driving conditions, they may have to be inspected more frequently.

Automatic transmission fluid & differential gear oil* Visually inspect for signs of leakage. Under severe driving conditions, the oil should be replaced at the specified interval.

Steering gear & linkage, axle & suspension parts Check for damage, looseness and leakage of oil or grease. Under severe driving conditions, more frequent inspection should be performed.

Steering linkage ball joints & front

MAINTENANCE

suspension ball joints Check the ball joints for damage, looseness and grease leakage.

Exhaust system Visually check the exhaust pipes, muffler, and hangers for proper attachment, leaks, cracks, chafing, abrasion, deterioration, etc. Under severe driving conditions, inspection should be performed more frequently.

Supplemental air bag system Check the supplemental air bag system components for proper attachment, damage, deformities, cracks, rust, etc. Work around and on the supplemental air bag system should be done by an authorized INFINITI dealer.

9 TECHNICAL AND CONSUMER INFORMATION

Major systems and how they work	9-2	When traveling or registering your vehicle	
Engine and drive train	9-2	in another country	9-23
Suspension and brake systems	9-8	Vehicle identification	9-24
Supplemental air bag system	9-12	Vehicle loading information	9-27
Capacities and recommended		Trailer towing	9-29
fuel/lubricants	9-14	Uniform tire quality grading	9-33
Recommended SAE viscosity number	9-19	Emission control system warranty	9-34
Engine	9-21	Reporting safety defects (For U.S.A.)	9-34
Wheels and tires	9-22	Readiness for Inspection/Maintenance	
Dimensions and weights	9-23	(I/M) test	9-35

TECHNICAL AND CONSUMER INFORMATION

MAJOR SYSTEMS AND HOW THEY WORK

The common theme that applies to almost all of the automotive systems described in this section is electronic controls. Because of their speed, precision and reliability, electronic components are used wherever possible to increase the efficiency and driveability of your INFINITI.

The typical control system employs “sensors”, which collect information about operating conditions and driver demand and send it, usually in the form of an electrical voltage signal, to an “engine control module”, which is a small, on-board computer. The engine control module monitors the information provided by the sensors, calculates the optimum or best control, and makes it happen through signals to electrical “actuators” in the engine or transmission or brake system—wherever the control must take place. The results can seem miraculous.

ENGINE AND DRIVE TRAIN

INFINITI VG30DE Engine with Electronic Concentrated Engine Control System (ECCS)

SUMMARY—ECCS ENGINE

The magic of the ECCS system is that it coordinates the functions and control of air-fuel mixture, ignition timing, exhaust gas recirculation, and idle speed by the operation of a high-speed computer. The precisely coordinated control of all of these functions allows the engine to operate more efficiently and emission free than would have been possible under earlier technologies.

TECHNICAL AND CONSUMER INFORMATION

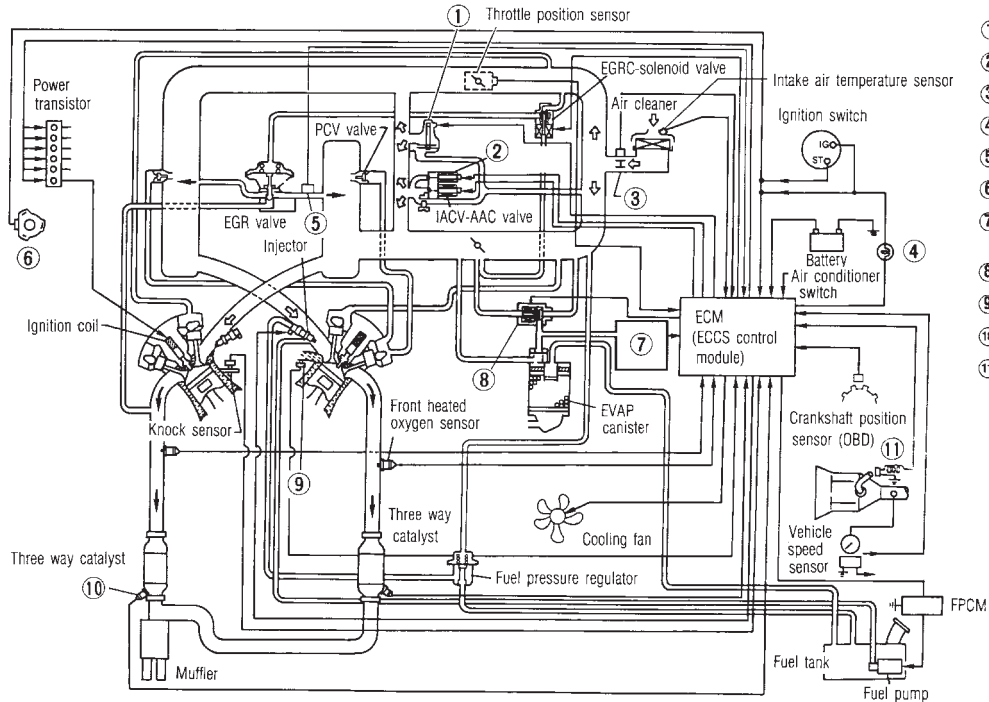

- ① IACV-air regulator
- ② IACV-FICD solenoid valve
- ③ Mass air flow sensor (Hot film type)
- ④ Malfunction indicator lamp
- ⑤ EGR temperature sensor
- ⑥ Camshaft position sensor
- ⑦ Canister control vacuum check switch
- ⑧ EVAP canister purge control solenoid valve
- ⑨ Engine coolant temperature sensor
- ⑩ Rear heated oxygen sensor
- ⑪ Park/neutral position switch

TECHNICAL AND CONSUMER INFORMATION

To get the most from an engine—in the way of performance, smooth driveability, economy and control of harmful emissions—a number of decisive factors must be controlled as precisely as possible under all driving conditions. These “factors” include the following:

- The timing and overlap of the intake and exhaust valves in relation to the position of the pistons in the engine.
- The mixture of air and fuel that enters the engine cylinders during each intake stroke of the pistons.
- The timing of the spark that ignites the pressurized charge of air and fuel near the end of the compression stroke of the pistons.
- The temperature of the combustion that occurs in the cylinders, especially under load.
- Engine idle speed under all conditions.

The engine in your INFINITI has degrees of precision in the automatic control of these factors that, only a few years ago, were not thought possible by any known technology. Such a high performance engine must operate smoothly and efficiently at all speed. And it must do so with a minimum of fuel consumption and a minimum of emissions into the environment.

MIXTURE CONTROL

A gasoline engine requires a relatively “rich” mixture of fuel to air during idle, a “lean” mixture for mid-range and “cruise” conditions, and a “richer” mixture for high load, high RPM operation. The changes in amount of fuel delivered to the engine must occur smoothly, sometimes in response to sudden changes in demand from the driver. The INFINITI ECCS can give the engine precisely the amount of fuel required for each condition, according to a precise measurement of the amount of air that is allowed into the engine

either through automatic devices provided for idle control or in response to your foot pressure on the vehicle throttle.

All of the atmospheric air that is drawn into the engine is measured by a mass air flow sensor.

This type of mass air flow sensor can respond very quickly to changes in intake air quantity and density, which means as you step on the throttle of your INFINITI to move into freeway traffic, a voltage signal is sent to the ECM (engine control module) instantly, and the ECM responds just as quickly to provide more fuel by allowing the port fuel injectors to stay open precise milliseconds longer. The result is smooth acceleration, without “stumble” or “hesitation”.

TECHNICAL AND CONSUMER INFORMATION

SEQUENTIAL MULTIPOINT FUEL INJECTION SYSTEM

Your INFINITI engine uses a separate fuel injector for each cylinder. These are placed into the intake ports, so that they can spray atomized fuel under pressure into the intake air stream. These injectors are controlled “sequentially”, which means that they operate in each cylinder according to the firing order. Each injector opens to spray its carefully metered amount of fuel just before the intake valve of the cylinder opens.

Constant Pressure

Fuel injector operation depends upon a supply of fuel that is always maintained at a constant pressure in relation to the pressure in the engine intake manifold. Under pressure, the fuel travels through the line, through a large and efficient fuel filter mounted under the hood, and into a “fuel rail” which feeds the injectors. Fuel flows into the bases of the

injectors, where it is available to flow out of the injector nozzles and into the intake ports when the injectors are opened electrically by signals from the ECM.

By allowing more or less fuel to return to the tank, the fuel pressure regulator maintains the pressure at the injectors at 36.3 psi (2.55 kg/cm², 250.1 kPa) above manifold pressure.

That allows the ECM to adjust the flow of fuel into the engine simply by controlling the amount of time the injectors stay open. The longer the injectors are held open, in milliseconds, the more fuel flow.

IGNITION TIMING CONTROL

For best efficiency, ignition timing must be dynamic, that is it must change depending upon the engine operating conditions. It must respond to engine load, RPM changes, engine temperature changes, altitude, and so on. For precisely correct, automatic, adjustments in ignition timing to take place, the ECM must

have sensors that tell about such conditions. The most important of these is the crank angle sensor. The camshaft position sensor tells the ECM the engine speed and the positions of the pistons under all conditions.

CONTROL OF COMBUSTION TEMPERATURE

Oxides of nitrogen, in a number of chemical variations, are among the major components of photochemical air pollution. These nitrogen oxide compounds are formed in the engine when the combustion temperatures are higher than about 2,000°F (1,093°C). One way to decrease nitrogen oxide formation in the engine, then, is to cool the temperature of combustion slightly. This is done by allowing a small amount of burned, and therefore inert, exhaust gases to recirculate back into the engine intake manifold where they can be drawn into the cylinders.

TECHNICAL AND CONSUMER INFORMATION

IDLE AIR CONTROL SYSTEM

The idle speed of an engine may be affected by a number of conditions. For example, a cold engine is inclined to run sluggishly at idle as well as under load. Such accessories as air conditioning and power steering may load the engine during idle and bring the idle speed down. Accessories that draw a large amount of current from the alternator, such as headlamps, window defoggers, radiator fans, etc., increase the load on the engine. So, to provide smooth idle under all conditions, and to provide the best overall fuel economy, the ECCS system gives computer controlled, automatic idle speed control. Using the information provided by the sensors, the ECM calculates the best idle speed and brings it about through the IACV-AAC valve, which allows more, or less, air into the intake manifold. Because the air is measured by the mass air flow sensor, the injectors always follow along

with the correct pulse duration, so the mixture is always correct.

ON-BOARD DIAGNOSTIC SYSTEM

The ECM (engine control module) has an on-board diagnostic system function, which monitors the engine and automatic transmission related circuits/components for problems. If the ECM senses a problem, it stores the information for retrieval by an experienced INFINITI technician at your dealership. So diagnosis and repair, even of this sophisticated system, may be made easier and more accurate.

TECHNICAL AND CONSUMER INFORMATION

INFINITI electronically controlled 4-speed automatic transmission

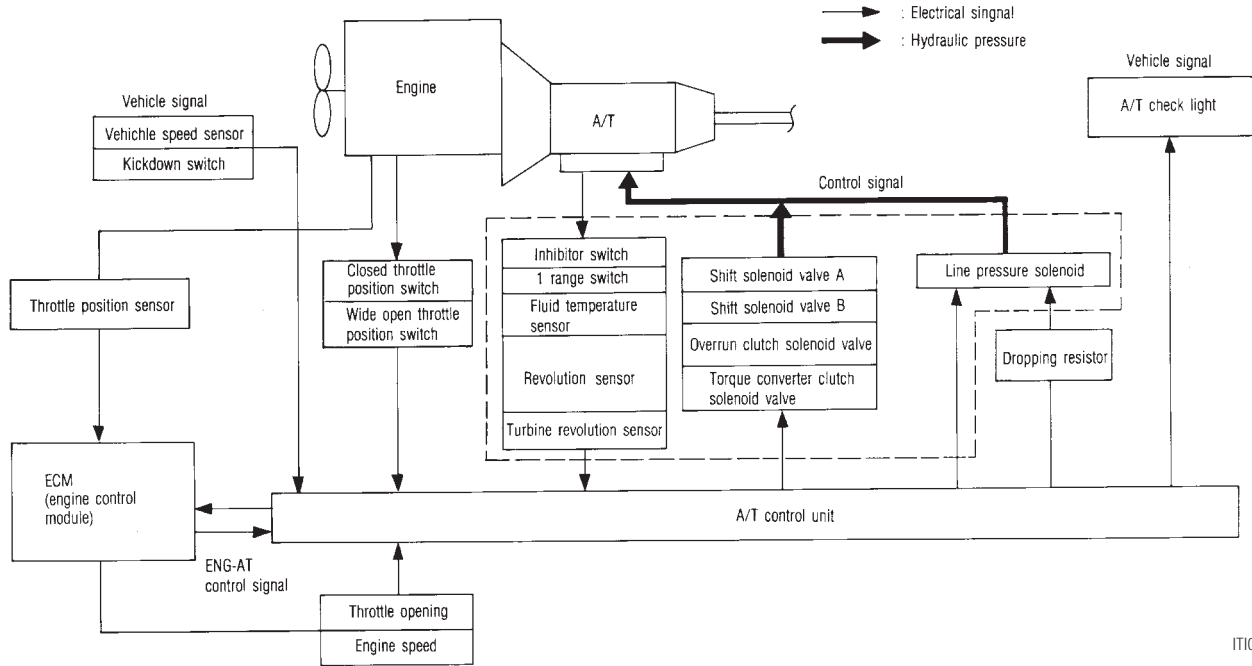

TECHNICAL AND CONSUMER INFORMATION

The function of an automotive transmission, is to provide a means of matching engine speed and vehicle speed in such a way that the engine is kept in the most efficient RPM range at all times.

Automatic Transmission Control Functions

Using the information provided by the sensors, the control unit calculates the best possible operation of the transmission for any condition by controlling the following functions:

1. Shift timing.
2. Lock-up timing.
3. Engine brake operation timing.

Self Diagnosis

Any electrical malfunction in the system will be sensed by the automatic transmission control unit, which stores the information in memory.

SUSPENSION AND BRAKE SYSTEMS

INFINITI multi-link rear suspension

Your INFINITI uses multi-link suspension at the rear wheels. This type of suspension allows for a comfortable ride and increased tire life, yet it gives excellent stability in hard cornering and braking. The multiple links control up and down and fore and aft movement of the wheels.

TECHNICAL AND CONSUMER INFORMATION

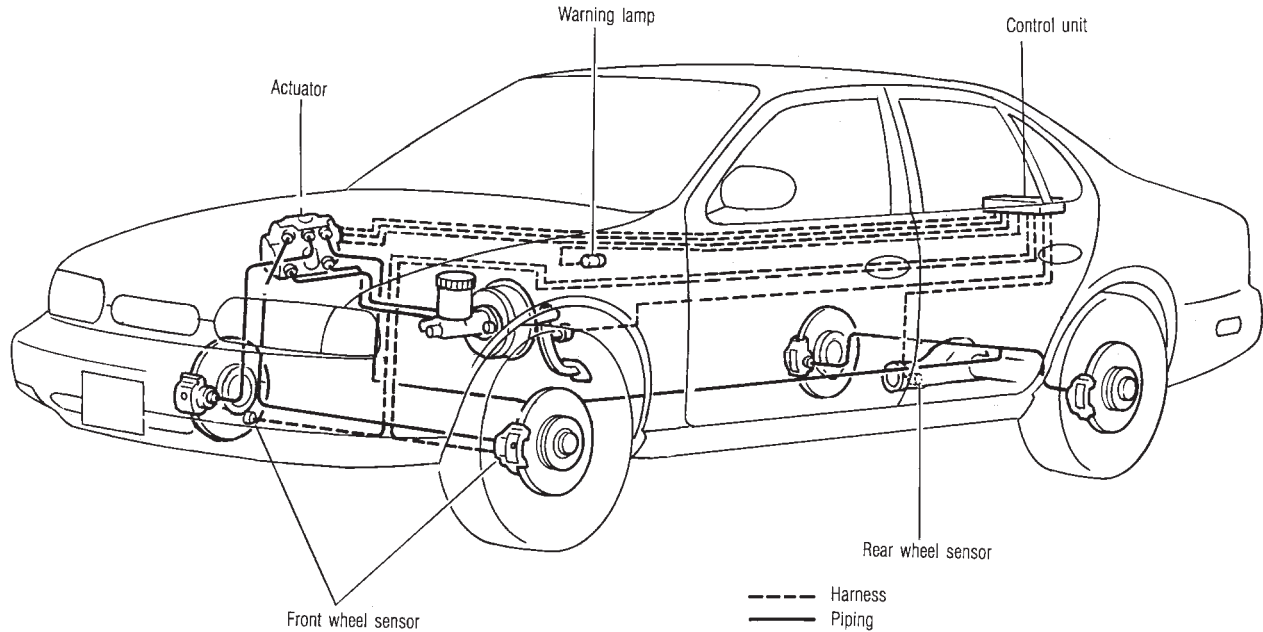

IT1021M

TECHNICAL AND CONSUMER INFORMATION

INFINITI Anti-Lock Brake System (ABS)

In sudden braking and on wet surfaces, the wheels are more easily locked. If the front wheels lock, steering control may be difficult.

If the rear wheels lock, swerving or spinning of the vehicle may result. To reduce this possibility, short and quick pumping of the brakes is needed, but this technique can be difficult for some drivers, especially in an emergency. The Anti-Lock braking system (ABS) can perform this pumping action quickly and is automatic when the driver depresses the brake pedal firmly. Since the braking force is controlled delicately by electronic control, wheel lock-up is minimized, and steering operation remains normal.

Brake pedal kickback remains minimal, and smooth pedal feel is ensured even when the ABS is operating.

System malfunction

If the ABS control unit detects a malfunction in any of the system electrical circuits, it will de-activate the anti-lock function by cutting electrical power to the ABS actuator. The braking system will then work as usual, without the anti-lock function.

If the control unit stops the ABS system operation, the ABS warning lamp will glow. This will aid your INFINITI dealership technician in diagnosis of the problem.

TECHNICAL AND CONSUMER INFORMATION

FOR YOUR DRIVING COMFORT-AUTOMATIC AIR CONDITIONING

For precision control over the interior climate of your INFINITI, there is a fully automatic air conditioning system. The system uses sensors, a control unit or "auto amplifier", and actuators to provide the most comfortable temperature, humidity and air flow inside the vehicle. The auto amplifier also has a self diagnosis feature to recognize any system circuit malfunction and aid your INFINITI dealership technician in a quick, accurate repair if it becomes necessary.

The auto amplifier receives information from the control panel, by which you may request the interior "weather" you wish, and from sensors placed in strategic locations in the vehicle. Once you have signaled a target temperature at the control panel, the auto amplifier uses information from the sensors to calculate what must be done.

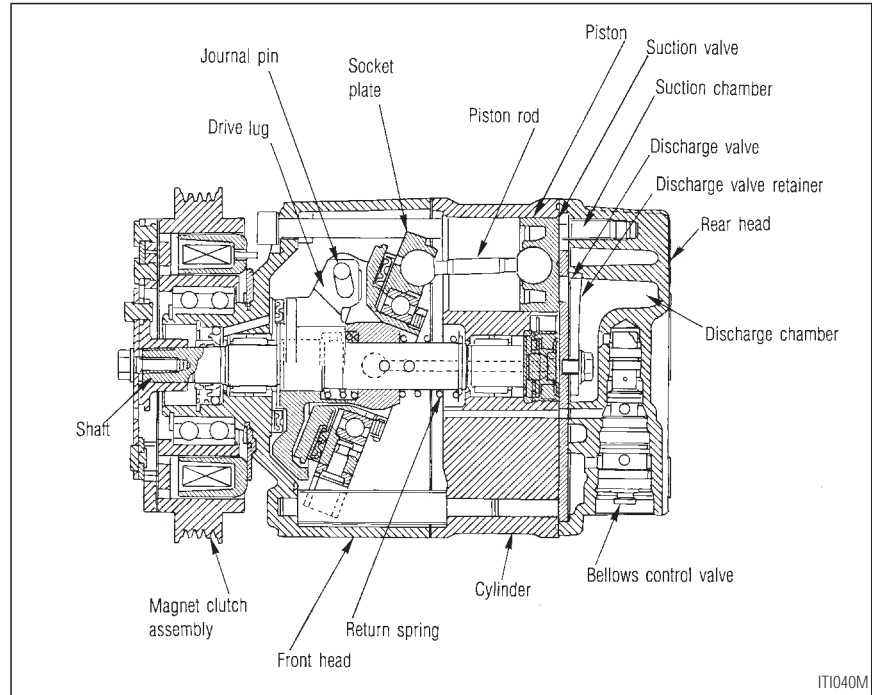

ITI040M

TECHNICAL AND CONSUMER INFORMATION

Hard clear coat (New cross linking clear coat)

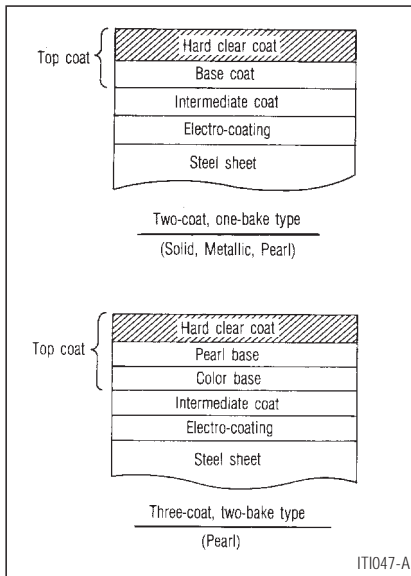

Your INFINITI paint coating has been applied with the finest appearance and best durability in mind:

- To ensure enhanced appearance, (i.e., solid, pearl and metallic paint clearness), the hard clear coat (2-coat/1-bake, or 3-coat/2-bake type) is used instead of the conventional clear coat (acrylic resin).
- Improved scratch resistance—
The hard clear coat has higher resistance against scratches which may be caused by car wash equipment than the conventional coats.
- Refinishing the clear coat should only be done using hard clear type materials, to ensure compatibility in the rate of refinisher gloss retention.

SUPPLEMENTAL AIR BAG SYSTEM

Supplemental air bags are designed to inflate in higher severity frontal collisions. When the supplemental air bag system receives a signal

from the diagnosis sensor unit, the supplemental air bags inside the supplemental air bag modules fill with gas, inflating instantly. This, in conjunction with the seat belts, helps to cushion the impact force to the occupants' face and chest.

A supplemental air bag system is provided on the front passenger side in addition to the driver side.

Pre-tensioner seat belt system

The front seat belt pre-tensioner, working with the retractor, helps tighten the seat belt when the vehicle is involved in certain types of collisions, thus helping to restrain the occupants on the front seats. This, in conjunction with the supplemental air bag systems, reduces impact forces to the occupants in a collision.

When the pre-tensioner receives a signal at the time of a collision, gas inside the cylinder installed on the retractor expands, thereby pushing up the piston to operate the retractor. The pre-tensioners will not usually operate when the vehicle is involved in side or

TECHNICAL AND CONSUMER INFORMATION

rear-end collisions or the seat belts are not fastened.

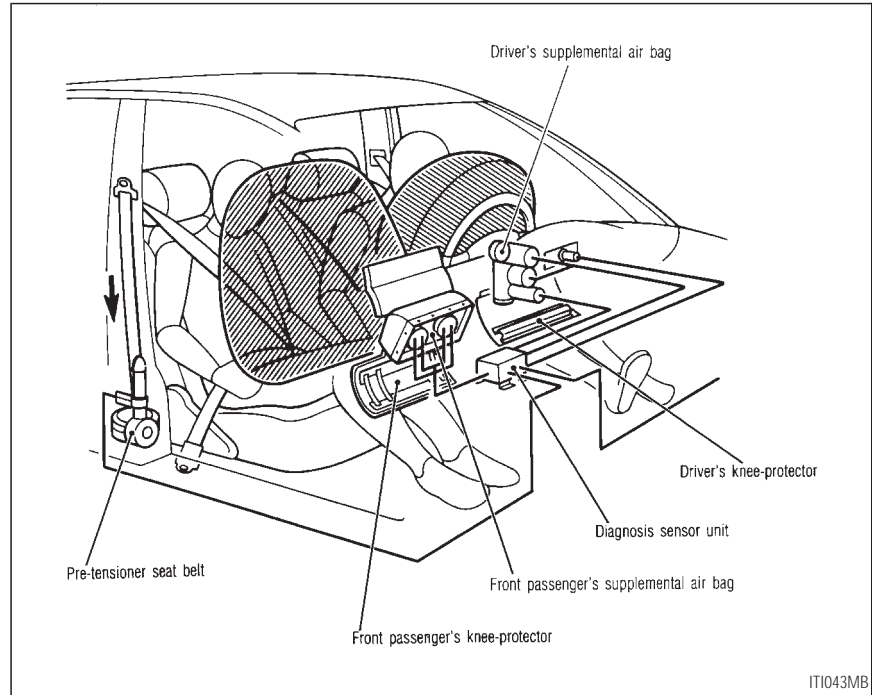

IT1043MB

TECHNICAL AND CONSUMER INFORMATION

CAPACITIES AND RECOMMENDED FUEL/LUBRICANTS

The following are approximate capacities. The actual refill capacities may be a little different. When refilling, follow the procedure instructed in the “Do-it-yourself” section to determine the proper refill capacity.

	Capacity (Approximate)			Recommended specifications
	US measure	Imp measure	Liter	
Fuel	19 gal	15-7/8 gal	72	Unleaded premium gasoline with an octane rating of at least 91 AKI (RON 96)*1
Engine oil (Refill)				<ul style="list-style-type: none"> ● API SG or SH and Energy Conserving II*2, *3 ● API Certification Mark*2, *3
With oil filter	4-1/2 qt	3-3/4 qt	4.3	
Without oil filter	4-1/8 qt	3-3/8 qt	3.9	
Cooling system				Anti-freeze coolant (Ethylene glycol base)
With reservoir	9-3/4 qt	8-1/8 qt	9.2	
Reservoir	1-1/8 qt	7/8 qt	1.0	
Differential gear oil	—	—	—	API GL-5*3
Automatic transmission fluid	Refill to the proper oil level according to the instructions in the “Do-it-yourself” section			Nissan Matic “D” (Continental U.S. and Alaska) or Genuine Nissan Automatic Transmission Fluid (Canada).*5
Power steering fluid				Type DEXRON™IIIE, DEXRON™IIII or equivalent
Brake fluid				Genuine Brake Fluid*4 or equivalent DOT 3 (US FMVSS No. 116)
Multi-purpose grease	—	—	—	NLGI No. 2 (Lithium soap base)
Air conditioning system refrigerant	—	—	—	HFC-134a (R-134a)
Air conditioning system lubricants				Nissan A/C System Oil Type S or equivalent

*1: For further details, see “Fuel requirement”.

*2: For further details, see “Engine oil and oil filter recommendation”.

*3: For further details, see “Recommended SAE viscosity number”.

*4: Available in mainland U.S.A. through your INFINITI dealer.

*5: Dexron® III/Mercon® or equivalent may also be used. Outside the continental United States and Alaska contact an INFINITI dealer for more information regarding suitable fluids, including recommended brand(s) of Dexron® III/Mercon® or Dexron® IIE/Mercon® Automatic Transmission Fluid.

TECHNICAL AND CONSUMER INFORMATION

FUEL REQUIREMENT

In order to maintain engine and exhaust system durability and performance, UNLEADED PREMIUM gasoline with an octane rating of at least 91 AKI (Research octane number 96) must be used.

If premium gasoline is not available, UNLEADED REGULAR gasoline with an octane rating of 87 AKI (Research octane number 91) may be temporarily used, but only under the following precautions:

- Have the fuel tank filled only partially with unleaded regular gasoline, and fill up with premium unleaded gasoline as soon as possible.
- Avoid full throttle driving and abrupt acceleration

Use UNLEADED fuel only. Under no circumstances should leaded gasoline be used. It will damage your three-way catalyst and increase dangerous emis-

sions from your vehicle exhaust.



CAUTION

Using a fuel other than that specified could adversely affect the emission control devices and systems, and could also affect warranty coverage.

Under no circumstances should a leaded gasoline be used, since this will damage the three way catalyst.

Reformulated gasoline

Some fuel suppliers are now producing reformulated gasolines. These gasolines are specially designed to reduce vehicle emissions. INFINITI supports efforts towards cleaner air and suggests that you use reformulated gasoline when available.

Gasoline containing oxygenates

Some fuel suppliers sell gasoline containing oxygenates such as ethanol, MTBE and methanol with or without advertising their presence. INFINITI does not recommend the use of fuels of which the oxygenate content and the fuel compatibility for your INFINITI cannot be readily determined. If in doubt, ask your service station manager.

If you use oxygenate-blend gasoline, please take the following precautions as the usage of such fuels may cause vehicle performance problems and/or fuel system damage.

- **The fuel should be unleaded and have an octane rating no lower than that recommended for unleaded gasoline.**
- **If an oxygenate-blend, excepting a methanol blend, is used, it should contain no more than 10% oxygen-**

TECHNICAL AND CONSUMER INFORMATION

ate. (MTBE may, however, be added up to 15%.)

- If a methanol blend is used, it should contain no more than 5% methanol (methyl alcohol, wood alcohol). It should also contain a suitable amount of appropriate cosolvents and corrosion inhibitors. If not properly formulated with appropriate cosolvents and corrosion inhibitors, such methanol blends may cause fuel system damage and/or vehicle performance problems. At this time, sufficient data is not available to ensure that all methanol blends are suitable for use in INFINITI vehicles.

If any undesirable driveability problems such as engine stalling and hard hot starting are experienced after using oxygenate-blend fuels, immediately change to a non-oxygenate fuel or a fuel with a low blend of MTBE.

Take care not to spill gasoline during refueling. Gasoline containing oxygenates can cause paint damage.

Aftermarket fuel additives

INFINITI does not recommend the use of any fuel additives (i.e. fuel injector cleaner, octane booster, intake valve deposit removers, etc.) which are sold commercially. Many of these additives intended for gum, varnish or deposit removal may contain active solvent or similar ingredients that can be harmful to the fuel system and engine.

Octane rating tips

In most parts of North America, you should use unleaded gasoline with an octane rating of at least 87 or 91 AKI (Anti-Knock Index) number. However, you may use unleaded gasoline with an octane rating as low as 85 AKI (Anti-Knock Index) number in these high altitude areas [over 4,000 ft (1,219 m)] such as: Colorado, Montana, New Mexico, Utah,

Wyoming, northeastern Nevada, southern Idaho, western South Dakota, western Nebraska, and that part of Texas which is directly south of New Mexico.

Using unleaded gasoline with an octane rating lower than stated above can cause persistent, heavy “spark knock”. (“Spark knock” is a metallic rapping noise.) **If severe, this can lead to engine damage. If you detect a persistent heavy spark knock even when using gasoline of the stated octane rating, or if you hear steady spark knock while holding a steady speed on level roads, have your dealer correct the condition. Failure to correct the condition is misuse of the vehicle, for which INFINITI is not responsible.**

Incorrect ignition timing will result in knocking, after-run or overheating. This in turn may cause excessive fuel consumption or damage to the engine. If any of the above symptoms

TECHNICAL AND CONSUMER INFORMATION

are encountered, have your vehicle checked at an INFINITI dealer or other competent service facility.

However, now and then you may notice light spark knock for a short time while accelerating or driving up hills. This is no cause for concern, because you get the greatest fuel benefit when there is light spark knock for a short time under heavy engine load.



ENGINE OIL AND OIL FILTER RECOMMENDATION

Selecting the correct oil

It is essential to choose the correct quality, and viscosity oil to ensure satisfactory engine life and performance. Nissan recommends the use of a low friction oil (energy conserving

oil) in order to improve fuel economy and conserve energy. Oils which do not have the specified quality label should not be used as they could cause engine damage.

Only those engine oils with the American Petroleum Institute (API) CERTIFICATION MARK on the front of the container should be

TECHNICAL AND CONSUMER INFORMATION

used. This type of oil supersedes the existing API SG or SH and Energy Conserving II categories.

If you cannot find engine oil with the CERTIFICATION MARK, an API SG or SH and Energy Conserving II oil with API Service Symbol may be used. An oil with a single designation "SG" or "SH", or in combination with other categories (for example, "SG/CC" or "SG/CD") may also be used if one with the API CERTIFICATION MARK cannot be found.

Mineral based or synthetic type oils may be used in your INFINITI vehicle. These oils must however, meet the API quality and SAE viscosity ratings specified for your vehicle. Do not mix mineral based and synthetic type oils in the engine at the same time.

Oil additives

INFINITI does not recommend the use of oil additives. The use of an oil additive is not necessary when the proper oil type is used

and maintenance intervals are followed.

Oil which may contain foreign matter or has been previously used should not be used.

Oil viscosity

The engine oil viscosity or thickness changes with temperature. Because of this, it is important that the engine oil viscosity be selected based on the temperatures at which the vehicle will be operated before the next oil change. The chart "Recommended SAE viscosity number" shows the recommended oil viscosities for the expected ambient temperatures. Choosing an oil viscosity other than that recommended could cause serious engine damage.

Selecting the correct oil filter

Your new vehicle is equipped with a high-quality genuine Nissan oil filter. When replacing, use the genuine oil filter or its equivalent for the reason described in "change intervals".

Change intervals

The oil and oil filter change intervals for your engine are based on the use of the specified quality oils and filters. Oil and filter other than the specified quality, or oil and filter change intervals longer than recommended could reduce engine life. Damage to engines caused by improper maintenance or use of incorrect oil and filter quality and/or viscosity is not covered by the new INFINITI vehicle warranties.

Your engine was filled with a high quality engine oil when it was built. You do not have to change the oil before the first recommended change interval. Oil and filter change intervals depend upon how you use your vehicle. Operation under the following conditions may require more frequent oil and filter changes.

TECHNICAL AND CONSUMER INFORMATION

- repeated short distance driving at cold outside temperatures,
- driving in dusty conditions,
- extensive idling,
- towing a trailer.

RECOMMENDED SAE VISCOSITY NUMBER

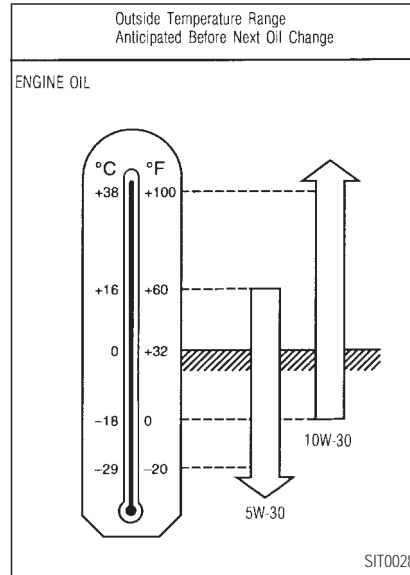

- SAE 10W-30 viscosity oil is preferable for ambient temperatures above 0°F (-18°C). SAE 5W-30 viscosity oil should be used only under extremely cold conditions.

TECHNICAL AND CONSUMER INFORMATION

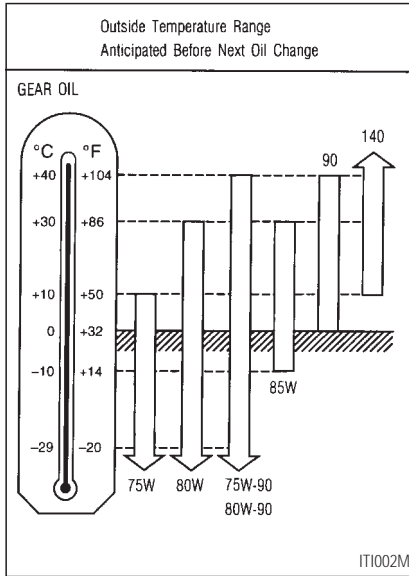

- For differential gear oil, 80W-90 is preferable for ambient temperatures below 104°F (40°C).

AIR CONDITIONING SYSTEM REFRIGERANT AND LUBRI- CANT RECOMMENDATIONS

The air conditioning in your INFINITI vehicle must be charged with the refrigerant HFC-134a (R-134a) and the lubricant, Nissan A/C system oil Type S or the exact equivalents.



CAUTION

Use of any other refrigerant or lubricant will cause severe damage and you will need to replace your vehicle's entire air conditioning system.

The refrigerant HFC-134a (R-134a) in your INFINITI vehicle will not harm the earth's ozone layer. Although this refrigerant does not affect the earth's atmosphere, certain governmental regulations require the recovery and recycling of any refrigerant during automotive

air conditioning system service. Your INFINITI dealer has the trained technicians and equipment needed to recover and recycle your air conditioning system refrigerant.

Contact your INFINITI dealer when servicing your air conditioning system.

TECHNICAL AND CONSUMER INFORMATION

ENGINE

Model		VG30DE
Type		Gasoline, 4-cycle
Cylinder arrangement		6-cylinder, V-slanted at 60°
Bore x Stroke	in (mm)	3.425 x 3.268 (87.0 x 83.0)
Displacement	cu in (cm ³)	180.62 (2,960)
Firing order		1-2-3-4-5-6*1
Idle speed	rpm	See the "Emission Control Label" on the underside of the hood.
Ignition timing (BTDC)	degree/rpm	
CO percentage at idle speed		[No air]
Spark plug	Standard	XFR5A-11 PFR5G-11 (PFR5B-11*3)
	Cold type	XFR6A-11 PFR6B-11 PFR6G-11
Camshaft operation		Timing belt*2
Alternator belt size		
Width x Length	in (mm)	0.559 x 39.96 (14.2 x 1,015)

*2: Periodic maintenance is necessary. Refer to "8 Maintenance".

*3: Equivalent to standard.

The spark ignition system of this vehicle meets all requirements of the Canadian Interference-Causing Equipment Regulations.

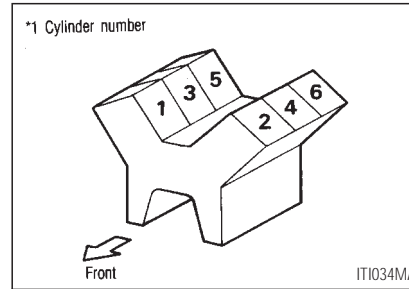

TECHNICAL AND CONSUMER INFORMATION

WHEELS AND TIRES

Road wheel	Aluminum	15 x 6-1/2 JJ
	Spare	16x4T*
	Offset	in (mm) 1.57 (40)

Tire size	Conventional	P215/60R15 93H
	Spare	T125/90D16 98M*

*: T-type spare wheel

TECHNICAL AND CONSUMER INFORMATION

DIMENSIONS AND WEIGHTS

		Sedan
Overall length	in (mm)	191.3 (4,859)
Overall width	in (mm)	69.7 (1,770)
Overall height	in (mm)	54.7 (1,389)
Front tread	in (mm)	59.1 (1,500)
Rear tread	in (mm)	58.9 (1,495)
Wheelbase	in (mm)	108.7 (2,760)
Gross vehicle weight rating	lb (kg)	
Gross axle weight rating		See the "F.M.V.S.S. certification label" on the driver's side lock pillar.
Front	lb (kg)	
Rear	lb (kg)	

WHEN TRAVELING OR REGISTERING YOUR VEHICLE IN ANOTHER COUNTRY

If you plan to travel in another country, you should first find out if the fuel available is suitable for your vehicle's engine.

Using fuel with too low an octane rating may cause engine damage. All gasoline vehicles must be operated with unleaded gasoline. Therefore, avoid taking your vehicle to areas where appropriate fuel is not available.

When transferring the registration of your vehicle to another country, state, province or district, it may be necessary to modify the vehicle to meet local laws and regulations.

The laws and regulations for motor vehicle emission control and safety standards vary according to the country, state, province or

TECHNICAL AND CONSUMER INFORMATION

district; therefore, vehicle specifications may differ.

When any vehicle is to be taken into another country, state, province or district and registered, its modifications, transportation, and registration are the responsibility of the user. INFINITI is not responsible for any inconvenience that may result.

VEHICLE IDENTIFICATION VEHICLE IDENTIFICATION NUMBER PLATE

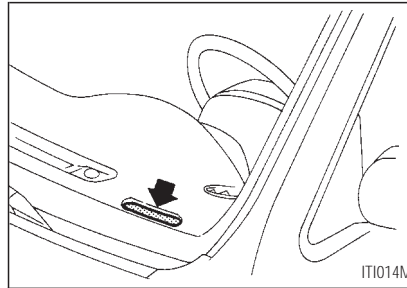

The vehicle identification number plate is attached as shown. This number is the identification for your vehicle and is used in the vehicle registration.

VEHICLE IDENTIFICATION NUMBER (Chassis number)

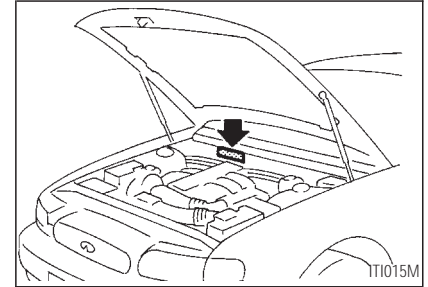

The number is stamped as shown.

TECHNICAL AND CONSUMER INFORMATION

ENGINE SERIAL NUMBER

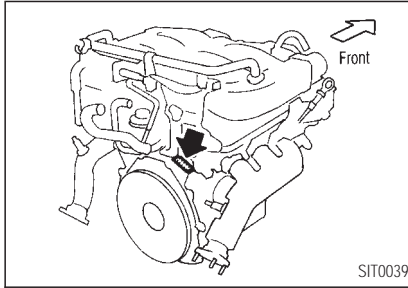

The number is stamped on the engine as shown.

F.M.V.S.S. CERTIFICATION LABEL

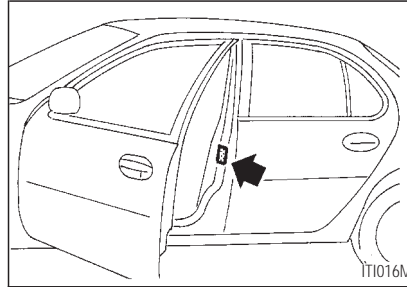

The F.M.V.S.S. certification label is affixed as shown.

EMISSION CONTROL INFORMATION LABEL

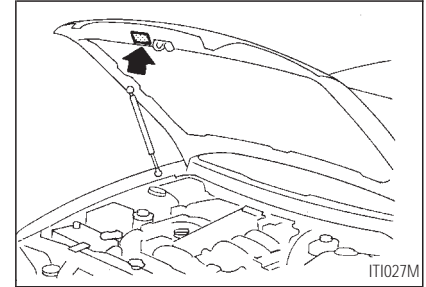

The emission control information label is attached as shown.

TECHNICAL AND CONSUMER INFORMATION

TIRE PLACARD

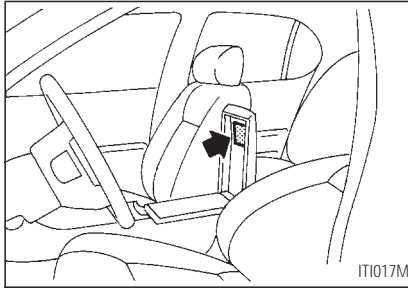

The cold tire pressure is shown on the tire placard affixed to the center console lid.

AIR CONDITIONER SPECIFICATION LABEL

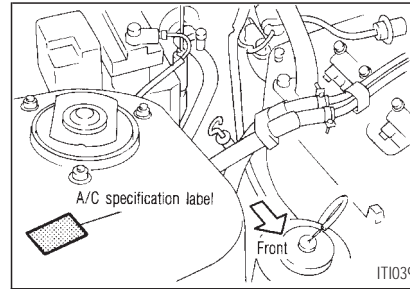

The air conditioner specification label is affixed on the strut tower as shown.

INSTALLING FRONT LICENSE PLATE

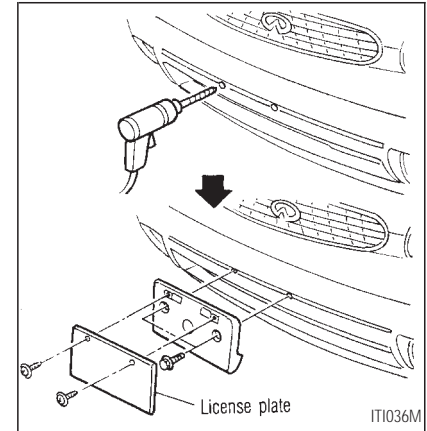

Use the following steps to mount the license plate:

1. Make a hole in each plastic finisher (the small rectangular pieces on the bumper) using a 0.31 in (8 mm) drill. Use the

TECHNICAL AND CONSUMER INFORMATION

location marks as a guide. To avoid damaging the threads behind the finisher, apply only light pressure to the drill.

2. Install the license plate bracket on the bumper.
3. Install the license plate on the bracket.

VEHICLE LOADING INFORMATION



WARNING

- *It is extremely dangerous to ride in a cargo area inside of a vehicle. In a collision, people riding in these areas are more likely to be seriously injured or killed.*
- *Do not allow people to ride in any area of your vehicle that is not equipped with seats and seat belts.*
- *Be sure everyone in your vehicle is in a seat and using a seat belt properly.*

Terms

It is important to familiarize yourself with the

following terms before loading your vehicle:

- Curb Weight (actual weight of your vehicle) - vehicle weight including: standard and optional equipment, fluids, emergency tools, and spare tire assembly. This weight **does not** include passengers and cargo.
- GVW (Gross Vehicle Weight) - curb weight plus the combined weight of passengers and cargo.
- GVWR (Gross Vehicle Weight Rating) - maximum total weight (load) limit specified for the vehicle.
- GAWR (Gross Axle Weight Rating) - maximum weight (load) limit specified for the front or rear axle.

Determining vehicle load capacity

The load capacity of this vehicle is determined by weight, not by available cargo space. For

TECHNICAL AND CONSUMER INFORMATION

example, a luggage rack, bike carrier, cartop carrier or similar equipment does not increase load carrying capacity of your vehicle.

To determine vehicle load capacity:

Vehicle weight can be determined by using a commercial-grade scale, found at places such as a truck stop, gravel quarry, grain elevator, or a scrap metal recycling facility.

- 1) Determine the curb weight of your vehicle.
- 2) Compare the curb weight amount to the GVWR specified for your vehicle to determine how much more weight your vehicle can carry.
- 3) After loading (cargo and passengers), re-weigh your vehicle to determine if either GVWR or GAWR for your vehicle is exceeded. If GVWR is exceeded, remove cargo as necessary. If either the front or rear GAWR is exceeded, shift the load or remove cargo as necessary.

Loading tips

- The GVW must not exceed GVWR or GAWR as specified on the FMVSS Certification Label.
- Do not load the front and rear axle to the GAWR. Doing so will exceed the GVWR.



CAUTION

- ***Properly secure all cargo to help prevent it from sliding or shifting. Do not place cargo higher than the seatbacks. In a sudden stop or collision, unsecured cargo could cause personal injury.***
- ***Do not load your vehicle any heavier than the GVWR or the maximum front and rear GAWRs.***

If you do, parts on your vehicle can break, or it can change the way your vehicle handles. This could result in loss of control and cause personal injury.

- ***Overloading can shorten the life of your vehicle. Failures caused by overloading are not covered by your warranty.***

TECHNICAL AND CONSUMER INFORMATION

TRAILER TOWING

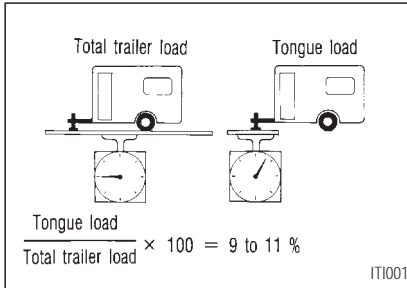

Your new vehicle was designed to be used primarily to carry passengers and cargo. Remember that towing a trailer will place additional loads on your vehicle's engine, drive train, steering, braking and other systems.

Information on trailer towing and the special equipment required should be obtained from a professional trailer dealer/installer.

Maximum load limits

Maximum trailer loads

Never allow the total trailer load to exceed 1,000 lb (454 kg). The total trailer load equals trailer weight plus its cargo weight. Towing loads greater than 1,000 lb (454 kg) or using improper towing equipment could adversely affect vehicle handling, braking and performance.

WARNING

Vehicle damage and/or personal injury resulting from improper towing procedures is not covered by INFINITI warranties. Information on trailer towing and required towing equipment should be obtained from dealers who specialize in providing trailers and other towing equipment.

Tongue load

Keep the tongue load between 9 and 11% of the total trailer load. If the tongue load becomes excessive, rearrange cargo to allow for proper tongue load.

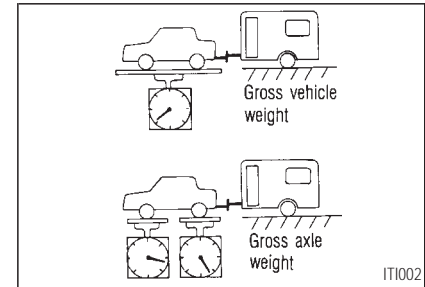

Maximum gross vehicle weight/maximum gross axle weight

The gross vehicle weight of the towing vehicle must not exceed the gross vehicle weight rating (GVWR) shown on the F.M.V.S.S. certification label. The gross vehicle weight

TECHNICAL AND CONSUMER INFORMATION

equals the combined weight of the unloaded vehicle, passengers, luggage, hitch, trailer tongue load and any other optional equipment. In addition, front or rear gross axle weight must not exceed the gross axle weight rating (GAWR) shown on the F.M.V.S.S. certification label.

TOWING LOAD/SPECIFICATION CHART

Unit: lb (kg)

MAXIMUM TOWING LOAD	1,000 (454)
MAXIMUM TONGUE LOAD	110 (49)

Trailer hitch

Choose a proper hitch for your vehicle and trailer. Make sure the trailer hitch is securely attached to the vehicle, to help avoid personal injury or property damage due to sway caused

by crosswinds, rough road surfaces or passing trucks.



CAUTION

- *Do not use axle-mounted hitches.*
- *The hitch should not be attached to or affect the operation of the impact-absorbing bumper.*
- *Do not modify the vehicle exhaust system, brake system, etc. when the hitch is installed.*
- *To reduce the possibility of additional damage if your vehicle is struck from the rear, where practical, remove the hitch when not in use. Remove the receiver when not in use.*

- *Regularly check that all hitch mounting bolts are securely mounted.*

Tire pressures

- When towing a trailer, inflate the vehicle tires to the recommended cold tire pressure indicated on the tire placard (located on the inside of the center console lid).
- Trailer tire condition, size, load rating and proper inflation pressure should be in accordance with the trailer and tire manufacturers' specifications.

Safety chain

Always use a suitable chain between your vehicle and the trailer. The chain should be crossed and should be attached to the hitch, not to the vehicle bumper or axle. Be sure to

TECHNICAL AND CONSUMER INFORMATION

leave enough slack in the chain to permit turning corners.

Trailer lights

Trailer lights should comply with Federal and/or local regulations. When wiring the vehicle for towing, connect the stop and tail light pickup into the vehicle electrical circuit at a point between the sensor and stop light switch or light switch.

Trailer brakes

If your trailer is equipped with a braking system, make sure it conforms to Federal and/or local regulations and that it is properly installed.



WARNING

Never connect a trailer brake system directly to the vehicle brake system.

Pre-towing tips

- Be certain your vehicle maintains a level position when a loaded or unloaded trailer is hitched. Do not drive the vehicle if it has an abnormal nose-up or nose-down condition; check for improper tongue load, overload, worn suspension or other possible causes of either condition.
- Always secure items in the trailer to prevent load shifts while driving.
- Be certain your rear view mirrors conform to all federal, state or local regulations. If not, install any mirrors required for towing before driving the vehicle.

Trailer towing tips

In order to gain skill and an understanding of the vehicle's behavior, you should practice turning, stopping and backing up in an area which is free from traffic. Steering stability, and braking performance will be somewhat

different than under normal driving conditions.

- Always secure items in the trailer to prevent load shift while driving.
- Avoid abrupt starts, acceleration or stops.
- Avoid sharp turns or lane changes.
- Always drive your vehicle at a moderate speed.
- Always block the wheels on both vehicle and trailer when parking. Parking on a slope is not recommended; however, if you must do so, and if your vehicle is equipped with automatic transmission, first block the wheels and apply the parking brake, and then move the transmission shift lever into the "P" position. If you move the shift lever to the "P" position before blocking the wheels and applying the parking brake, transmission damage could occur.

TECHNICAL AND CONSUMER INFORMATION

- When going down a hill, shift into a lower gear and use the engine braking effect. When ascending a long grade, downshift the transmission to a lower gear and reduce speed to reduce chances of engine overloading and/or overheating.
- If the engine coolant rises to an extremely high temperature when the air conditioning system is on, turn off the air conditioner. Coolant heat can be additionally vented by opening the windows, switching the fan control to high and setting the temperature control to the "HOT" position.
- Trailer towing requires more fuel than normal circumstances.
- Avoid towing a trailer for the first 500 miles (800 km).
- Have your vehicle serviced more often than at intervals specified in the recommended maintenance schedule.
- When making a turn, your trailer wheels will be closer to the inside of the turn than your vehicle wheels. To compensate for this, make a larger than normal turning radius during the turn.
- Crosswinds and rough roads will adversely affect vehicle/trailer handling, possibly causing vehicle sway. When being passed by larger vehicles, be prepared for possible changes in crosswinds that could affect vehicle handling. If swaying does occur, firmly grip the steering wheel, steer straight ahead, and immediately (but gradually) reduce vehicle speed. This combination will help stabilize the vehicle. Never increase speed.
- Be careful when passing other vehicles. Passing while towing a trailer requires considerably more distance than normal passing. Remember the length of the trailer must also pass the other vehicle before you can safely change lanes.
- To maintain engine braking efficiency and electrical charging performance, do not use overdrive (automatic transmission).
- Avoid holding the brake pedal down too long or too frequently. This could cause the brakes to overheat, resulting in reduced braking efficiency.

When towing a trailer, change fluid in the transmission more frequently.

See the "Maintenance" section.

TECHNICAL AND CONSUMER INFORMATION

UNIFORM TIRE QUALITY GRADING

DOT Quality Grades: All passenger car tires must conform to Federal Safety Requirements in addition to these grades.

Treadwear

Treadwear grade is a comparative rating based on tire wear rate when tested under controlled conditions on specified government test courses. For example, a tire graded 150 would wear one and a half (1-1/2) times as well on the government course as a tire graded 100. However, relative tire performance depends on actual driving conditions, and may vary significantly from the norm due to variations in driving habits, service practices and differences in road characteristics and climate.

Traction A, B and C

Traction grades are A (the highest), B and C. They represent a tire's ability to stop on wet

pavement as measured under controlled conditions, on specified government test surfaces of asphalt and concrete. A tire marked with a C may have poor traction performance.



WARNING

The traction grade assigned to your vehicle tires is based on straight line braking traction tests and does not include cornering (turning) traction.

Temperature A, B and C

Temperature grades are A (the highest), B, and C. They represent a tire's resistance to heat build-up, and its ability to dissipate heat when tested under controlled conditions on a specified indoor laboratory test wheel. Sustained high temperature can cause tire material to degenerate, reducing tire life. Excessive temperatures can lead to sudden tire failure.

Grade C corresponds to a performance level which all passenger car tires must meet under the Federal Motor Vehicle Safety Standard No. 109. Grades A and B represent higher levels of performance on laboratory test wheels than the minimum required by law.



WARNING

The temperature grade is established for a tire that is properly inflated and not overloaded. Excessive speed, underinflation, or excessive loading, either separately or in combination, can cause heat build-up and possible tire failure.

TECHNICAL AND CONSUMER INFORMATION

EMISSION CONTROL SYSTEM WARRANTY

Your INFINITI is covered by the following emission warranties.

For U.S.A.

- 1) Emission Defects Warranty
- 2) Emissions Performance Warranty
(See Warranty Information Booklet for details.)

For Canada

Emission Control System Warranty

Details of these warranties may be found with other vehicle warranties in your Warranty Information Booklet that comes with your INFINITI. If you did not receive a Warranty Information Booklet, or it has become lost, you may obtain a replacement by writing to:

- INFINITI Division, Nissan
Nissan Motor Corporation U.S.A.

Consumer Affairs Department
P.O. Box 191, Gardena, CA 90248-0191

- Nissan Canada Inc.
P.O. Box 1709, Station "B"
Mississauga, Ontario,
L4Y 4H6
- INFINITI Division
Nissan Motor Corporation in Hawaii, Ltd.
Consumer Affairs Department
2880 Kilihau Street
Honolulu, Hawaii 96819

REPORTING SAFETY DEFECTS (For U.S.A.)

If you believe that your vehicle has a defect which could cause a crash or could cause injury or death, you should immediately inform the National Highway Traffic Safety Administration (NHTSA) in addition to notifying INFINITI.

If NHTSA receives similar complaints, it may open an investigation, and if it finds that a safety defect exists in a group of vehicles, it may order a recall and remedy campaign. However, NHTSA cannot become involved in individual problems between you, your dealer, or INFINITI.

To contact NHTSA, you may either call the Auto Safety Hotline toll-free at 1-800-424-9393 (or 366-0123 in Washington, D.C. area) or write to: NHTSA, U.S. Department of Transportation, Washington, D.C. 20590. You can also obtain other information about motor vehicle safety from the Hotline.

You may notify INFINITI by contacting our Consumer Affairs Department, toll-free, at 1-800-662-6200. In Hawaii call 808-836-0848.

TECHNICAL AND CONSUMER INFORMATION

READINESS FOR INSPECTION/MAINTENANCE (I/M) TEST

Due to legal requirements in some states/areas, your vehicle may be required to be in what is called the “ready condition” for an Inspection/Maintenance (I/M) test of the emission control system.

The vehicle is set to the “ready condition” when it is driven through certain driving patterns. Usually, the ready condition can be obtained by ordinary usage of the vehicle.

If a powertrain system component is repaired or the battery is disconnected, the vehicle may be reset to a “not ready” condition. Before taking the I/M test, drive the vehicle through the following pattern to set the vehicle to the ready condition. If you cannot or do not want to perform the driving pattern, an INFINITI dealer can conduct it for you.



WARNING

Always drive the vehicle in a safe manner according to traffic conditions and obey all traffic laws.

1. Start the engine when the engine coolant temperature gauge needle points to “C”. Allow the engine to idle until the gauge needle points between the “C” and “H” (normal operating temperature).
 2. Accelerate the vehicle to 55 MPH (88 km/h), then quickly release the accelerator pedal completely and keep it released for at least 6 seconds.
 3. Quickly depress the accelerator pedal for a moment, then drive the vehicle at a speed of 53 to 60 MPH (86 to 96 km/h) for at least 5 minutes.
 4. Stop the vehicle and turn the engine off.
 5. Repeat steps 1 through 4 at least one more time.
- If step 1, 2 or 3 is interrupted, repeat the preceding step. Any safe driving mode is acceptable between steps. Do not stop the engine until step 3 is completed.

A

Air cleaner.....	7-17
Air conditioner	
Air conditioner specification label.....	9-26
Air conditioner system refrigerant and lubrication recommendations.....	9-20
AM radio reception.....	3-8
Anti-lock brake system.....	4-17
Audio main operation.....	3-10
Automatic	
Automatic anti-dazzling inside mirror.....	2-45
Automatic transmission fluid.....	7-11
Driving with automatic transmission.....	4-6
For your driving comfort-automatic air conditioning.....	9-11
Power window automatic switch.....	1-21
Avoiding collision and rollover.....	4-4

B

Battery.....	7-14
Battery replacement.....	2-8
Before starting the engine.....	4-6
Book holder.....	1-19

Brake

Anti-lock brake system.....	4-17
Brake booster.....	7-20
Brake fluid.....	7-13
Brake pedal.....	7-19
Brake system.....	4-16
Brake wear indicators.....	1-10, 7-19
Parking brake.....	4-11, 7-19
Suspension and brake systems.....	9-8
Break-in schedule.....	4-14

C

Capacities and recommended fuel/lubricants.....	9-14
Cargo net.....	1-19
Cargo (See "Vehicle loading information").....	9-27
Cassette tape player operation.....	3-13
Center sunvisor.....	2-45
Changing	
Changing engine coolant.....	7-6
Changing engine oil.....	7-9
Changing engine oil filter.....	7-10
Checking engine coolant level.....	7-6
Checking engine oil level.....	7-8
Child restraints for infants and small children.....	2-35

Child safety rear door lock.....	2-3
Cigarette lighters and ashtrays.....	1-17
Cleaning exterior and interior.....	6-2
Clock.....	1-22
Cold weather driving.....	4-19
Compact disc (CD) player operation.....	3-15
Console light.....	1-23
Control of combustion temperature.....	9-5
Coolant	
Changing engine coolant.....	7-6
Checking engine coolant level.....	7-6
Engine coolant temperature gauge.....	1-5
Corrosion protection.....	6-6
Cruise control.....	4-12
Cup holder.....	1-18

D

Defogger switch	
Rear window and outside door mirror defogger switch.....	1-13
Dimensions and weights.....	9-23
Door locks.....	2-2
Drinking alcohol/drugs and driving.....	4-4
Drive belts.....	7-15

INDEX

Driving	
Cold weather driving.....	4-19
Driving with automatic transmission.....	4-6
For your driving comfort-automatic air conditioning	9-11
Precautions when starting and driving.....	4-2

E

Economy hints.....	4-14
Emission control.....	9-34
Emission control information label	9-25
Engine.....	9-21
Before starting the engine.....	4-6
Changing engine coolant.....	7-6
Changing engine oil	7-9
Changing engine oil filter	7-10
Checking engine coolant level.....	7-6
Checking engine oil level	7-8
Engine and drive train	9-2
Engine coolant temperature gauge	1-5
Engine cooling system.....	7-5
Engine oil.....	7-8
Engine oil and oil filter recommendation.....	9-17
Engine serial number.....	9-25

Starting the engine.....	4-10
Exhaust gas (Carbon monoxide).....	4-2
Explanation of maintenance items.....	8-11

F

Flat tire.....	5-2
Fluid	
Automatic transmission fluid.....	7-11
Brake fluid.....	7-13
Power steering fluid.....	7-13
Window washer fluid	7-14
FM radio reception.....	3-7
F.M.V.S.S. certification label	9-25
Foldable outside mirrors	2-45
For your driving comfort-automatic air conditioning	9-11
Freeing vehicle from sand, snow or mud.....	5-12
Fuel	
Capacities and recommended fuel/lubricants.....	9-14
Fuel filler cap.....	2-12
Fuel filler cap holder	2-12
Fuel filler lid lock	2-11
Fuel gauge	1-5
Fuel requirement.....	9-15, 10-6

Sequential multiport fuel injection system.....	9-5
Fuses.....	7-20
Fusible links	7-22

G

Gauge	
Engine coolant temperature gauge	1-5
Fuel gauge	1-5
General maintenance.....	8-2
Glove box lock.....	2-10

H

Hazard warning flasher switch.....	1-15
Head restraints.....	2-16
Headlight and turn signal switch	1-13
Headlights	7-22
Heated seat	1-16
Hood release.....	2-9
How to use multi-remote control system.....	2-6

I

Idle air control system.....	9-6
------------------------------	-----

INDEX

If the sunroof does not close.....	1-22
If your vehicle overheats.....	5-9
Ignition switch.....	4-5
Ignition timing control.....	9-5
Installing front license plate.....	9-26
Instrument brightness control.....	1-15
Interior light.....	1-22

J

Jump starting.....	5-6, 7-15
--------------------	-----------

K

Key.....	2-2
----------	-----

L

License plate	
Installing front license plate.....	9-26
Light	
Console light.....	1-23
Headlight and turn signal switch.....	1-13
Headlights.....	7-22
Interior light.....	1-22

Light bulbs.....	7-22
Supplemental air bag warning light.....	2-25
Vanity mirror light.....	1-23
Warning/indicator light and chime.....	1-6
Lock	
Anti-lock brake system.....	4-17
Child safety rear door lock.....	2-3
Door locks.....	2-2
Fuel filler lid lock.....	2-11
Glove box lock.....	2-10
Power door lock.....	2-4
Trunk lid lock.....	2-10
Luggage (See "Vehicle loading information").....	9-27

M

Maintenance	
Explanation of maintenance items.....	8-11
General maintenance.....	8-2
Periodic maintenance.....	8-5
Readiness for inspection/maintenance (I/M) test.....	9-35
Seat belt maintenance.....	2-35
Major systems and how they work.....	9-2

Mirror	
Automatic anti-dazzling inside mirror.....	2-45
Foldable outside mirrors.....	2-45
Rear window and outside door mirror defogger switch.....	1-13
Vanity mirror light.....	1-23
Mixture control.....	9-4
Multi-remote control system.....	2-5

O

Odometer.....	1-4
Oil	
Changing engine oil.....	7-9
Changing engine oil filter.....	7-10
Checking engine oil level.....	7-8
Engine oil.....	7-8
Engine oil and oil filter recommendation.....	9-17
On-board diagnostic system.....	9-6
Outboard shoulder/lap belt.....	2-39
Overheat	
If your vehicle overheats.....	5-9

INDEX

P

Parking	
Parking brake.....	4-11, 7-19
Parking/parking on hills.....	4-15
Periodic maintenance.....	8-5
Power	
Power assisted system.....	4-16
Power door lock.....	2-4
Power seat.....	2-13
Power steering fluid.....	7-13
Power window.....	1-20
Power window automatic switch.....	1-21
Precautions	
Precautions on seat belt usage.....	2-28
Precautions when starting and driving.....	4-2
Push starting.....	5-9

R

Radio.....	3-7
AM radio reception.....	3-8
FM radio reception.....	3-7
Radio operation.....	3-11
Radio reception.....	3-7

Readiness for inspection/maintenance (I/M) test.....	9-35
Rear window and outside door mirror defogger switch.....	1-13
Recommended SAE viscosity number.....	9-19
Refrigerant recommendation.....	9-20
Reporting safety defects (For U.S.A.).....	9-34
Roadside assistance program.....	5-2

S

Safety	
Child safety rear door lock.....	2-3
Reporting safety defects (For U.S.A.).....	9-34
Seat belt	
3-point type with retractor.....	2-31
Precautions on seat belt usage.....	2-28
Seat belt extenders.....	2-35
Seat belt maintenance.....	2-35
Seat belts.....	2-27
Seats.....	2-13
Sequential multiport fuel injection system.....	9-5
Spark plug replacement.....	7-16
Speedometer.....	1-4
Starting	
Before starting the engine.....	4-6

Jump starting.....	5-6, 7-15
Precautions when starting and driving.....	4-2
Push starting.....	5-9
Starting the engine.....	4-10
Steering	
Power steering fluid.....	7-13
Tilting steering wheel.....	2-44
Sunroof.....	1-21
Supplemental.....	2-16
Supplemental air bag system.....	9-12
Supplemental air bag warning light.....	2-25
Suspension and brake systems.....	9-8
Switch	
Hazard warning flasher switch.....	1-15
Headlight and turn signal switch.....	1-13
Ignition switch.....	4-5
Power window automatic switch.....	1-21
Rear window and outside door mirror defogger switch.....	1-13
Trunk lid release cancel switch.....	2-11
Windshield wiper and washer switch.....	1-12

T

Tachometer.....	1-4
-----------------	-----

INDEX

Temperature conditions for checking	7-11
Three way catalyst	4-3
Tilting steering wheel	2-44
Timing belt.....	9-21
Tire	
Flat tire	5-2
Tire placard	9-26
Tire pressure	7-30
Uniform tire quality grading	9-33
Wheels and tires	7-30, 9-22
Tow truck towing	5-10
Towing	
Tow truck towing	5-10
Towing load/specification chart	9-30
Trailer towing	9-29
Trailer towing.....	9-29
Transmission	
Automatic transmission fluid.....	7-11
Driving with automatic transmission	4-6
Trip odometer	1-4
Trunk lid lock	2-10
Trunk lid release cancel switch.....	2-11

U

Uniform tire quality grading	9-33
------------------------------------	------

V

Vanity mirror light	1-23
Vehicle identification.....	9-24
Vehicle identification number (Chassis number).....	9-24
Vehicle identification number plate	9-24
Vehicle loading information.....	9-27
Ventilator	3-2

W

Warning	
Hazard warning flasher switch.....	1-15
Supplemental air bag warning light	2-25
Warning labels	2-25
Warning/indicator light and chime.....	1-6
Wheels and tires.....	7-30, 9-22
When traveling or registering your	9-23
Window washer fluid	7-14
Windshield wiper and washer switch.....	1-12

Wiper

Windshield wiper and washer switch.....	1-12
Wiper blade.....	7-17

MEMO

MEMO

MEMO

MEMO

GAS STATION INFORMATION

Fuel requirement

In order to maintain engine and exhaust system durability and performance, UNLEADED PREMIUM gasoline with an octane rating of at least 91 AKI (Research octane number 96) must be used.

If premium gasoline is not available, UNLEADED REGULAR gasoline with an octane rating of 87 AKI (Research octane number 91) may be temporarily used, but only under the following precautions:

- Have the fuel tank filled only partially with unleaded regular gasoline, and fill up with premium unleaded gasoline as soon as possible.
- Avoid full throttle driving and abrupt acceleration



CAUTION

Use UNLEADED fuel only. Under no circumstances should leaded gasoline be used. It will damage your three-way catalyst and increase dangerous emissions from your vehicle exhaust.

Recommended engine oil specifications:

- API SG or SH and Energy Conserving II
- API Certification Mark
- SAE 10W-30 viscosity oil is preferred for ambient temperatures above 0°F (-18°C). See "Engine oil and oil filter recommendation" in the "Technical and consumer information" section.

Tire cold pressure:

See tire placard affixed to the center console lid.

Recommended new vehicle break-in procedure:

During the first 1,000 miles (1,600 km) of vehicle use, follow the recommendations outlined in the "BREAK-IN SCHEDULE" Information found in the "Starting and driving" section of this Owner's Manual. Follow these recommendations for the future reliability and economy of your new vehicle. Failure to follow these recommendations may result in vehicle damage or shortened engine life.

QUICK REFERENCE

