

FOREWORD

Your INFINITI represents a new way of thinking about vehicle design. It integrates advanced engineering and superior craftsmanship with a simple, refined aesthetic sensitivity associated with traditional Japanese culture.

The result is a different notion of luxury and beauty. The car itself is important, but so also is the sense of harmony that the vehicle evokes in its driver, and the sense of satisfaction you feel with the INFINITI—from the way it looks and drives to the high level of dealer service.

To ensure that you enjoy your INFINITI to the fullest, we encourage you to read this Owner's Manual immediately. It explains all of the features, controls and performance characteristics of your INFINITI; it also provides important instructions and safety information.

A separate Warranty Information Booklet is to be found in your Owner's literature portfolio. Always carry it with you when you take your INFINITI to an authorized dealer. The portfolio contents provide complete information about all warranties covering this vehicle, the periodic maintenance required

to keep the warranties in effect as well as the INFINITI Roadside Assistance program.

Additionally, a separate Customer Care and Lemon Law Information Booklet will explain how to resolve any concerns you may have with your vehicle, as well as clarify your rights under your state's lemon law.

INFINITI is dedicated to providing a satisfying ownership experience for as long as you own your car. Should you have any questions regarding your INFINITI or your INFINITI retailer, please contact our Consumer Affairs department at 1-800-662-6200. In Hawaii 1-808-836-0848 (Oahu number). In Canada 1-800-361-4792. Thank you.

READ FIRST — THEN DRIVE SAFELY

Before driving your vehicle please read your Owner's Manual carefully. This will ensure familiarity with controls and maintenance requirements, assisting you in the safe operation of your vehicle.



WARNING

IMPORTANT SAFETY INFORMATION REMINDERS FOR SAFETY!

Follow these important driving rules to help ensure a safe and comfortable trip for you and your passengers!

- Never drive under the influence of alcohol or drugs.
- Always observe posted speed limits and never drive too fast for conditions.
- Always use your seat belts and appropriate child restraint systems. Preteen children should be seated in the rear seat.
- Always provide information about the proper use of vehicle safety

features to all occupants of the vehicle.

- Always review this Owner's Manual for important safety information.

As with other vehicles with features for offroad use, failure to operate four wheel drive models correctly may result in loss of control or an accident. For additional information, see "Driving four wheel drive safely" in the "5. Starting and driving" section.

ON-PAVEMENT AND OFF-ROAD DRIVING

This vehicle will handle and maneuver differently from an ordinary passenger car because it has a higher center of gravity for offroad use. As with other vehicles with features of

this type, failure to operate this vehicle correctly may result in loss of control or an accident.

For additional information, see "On-pavement and offroad driving precautions" and "Avoiding collision and rollover" in the "5. Starting and driving" section.

MODIFICATION OF YOUR VEHICLE

This vehicle should not be modified. Modification could affect its performance, safety or durability, and may even violate governmental regulations. In addition, damage or performance problems resulting from modification may not be covered under INFINITI warranties.

WHEN READING THE MANUAL

This manual includes information for all options available on this model. Therefore, you may find some information that does not apply to your vehicle.

All information, specifications and illustrations in this manual are those in effect at the time of printing. INFINITI reserves the right to change specifications or design at any time without notice.

IMPORTANT INFORMATION ABOUT THIS MANUAL

You will see various symbols in this manual. They are used in the following ways:



WARNING

This is used to indicate the presence of a hazard that could cause death or

serious personal injury. To avoid or reduce the risk, the procedures must be followed precisely.



CAUTION

This is used to indicate the presence of a hazard that could cause minor or moderate personal injury or damage to your vehicle. To avoid or reduce the risk, the procedures must be followed carefully.

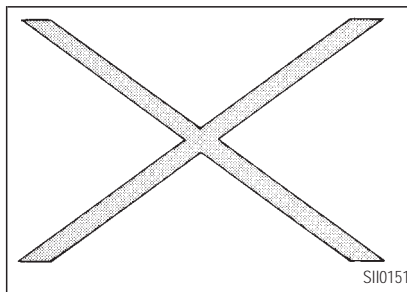

If you see this symbol, it means **Do not do this** or **Do not let this happen.**



INFINITI®

© 2002 NISSAN MOTOR CO., LTD.
TOKYO, JAPAN

All rights reserved. No part of this Owner's Manual may be reproduced or stored in a retrieval system, or transmitted in any form, or by any means, electronic, mechanical, photocopying, recording or otherwise, without the prior written permission of Nissan Motor Co., Ltd.

CALIFORNIA PROPOSITION 65 WARNING



WARNING

Engine Exhaust, some of its constituents, and certain vehicle components contain or emit chemicals known to State of California to cause cancer and birth defects or other reproductive harm.

TABLE OF CONTENTS

SEATS, RESTRAINTS AND SUPPLEMENTAL AIR BAG SYSTEMS	1-1
INSTRUMENTS AND CONTROLS	2-1
PRE-DRIVING CHECKS AND ADJUSTMENTS.....	3-1
HEATER, AIR CONDITIONER AND AUDIO SYSTEMS	4-1
STARTING AND DRIVING.....	5-1
IN CASE OF EMERGENCY	6-1
APPEARANCE AND CARE.....	7-1
DO-IT-YOURSELF	8-1
MAINTENANCE	9-1
TECHNICAL AND CONSUMER INFORMATION	10-1
INDEX	11-1

1 SEATS, RESTRAINTS AND SUPPLEMENTAL AIR BAG SYSTEMS

Seats.....	1-2	Three-point type seat belt with retractor.....	1-28
Front power seat adjustment.....	1-3	Two-point type seat belt without retractor (Center of rear seat).....	1-31
Rear seat adjustment.....	1-4	Seat belt extenders.....	1-33
Head restraint adjustment.....	1-7	Seat belt maintenance.....	1-34
Active head restraint (For front seats)...	1-7	Child restraints.....	1-34
Armrest.....	1-8	Precautions on child restraints.....	1-34
Supplemental restraint system.....	1-8	Installation on rear seat center position.....	1-36
Precautions on supplemental restraint system.....	1-8	Installation on rear seat outboard positions.....	1-39
Supplemental air bag warning labels...	1-21	LATCH (Lower anchors and tether for children) system.....	1-44
Supplemental air bag warning light.....	1-21	Top tether strap child restraint.....	1-45
Seat belts.....	1-23	Installation on front passenger seat....	1-47
Precautions on seat belt usage.....	1-23		
Child safety.....	1-26		
Pregnant women.....	1-27		
Injured persons.....	1-27		

SEATS, RESTRAINTS AND SUPPLEMENTAL AIR BAG SYSTEMS

SEATS

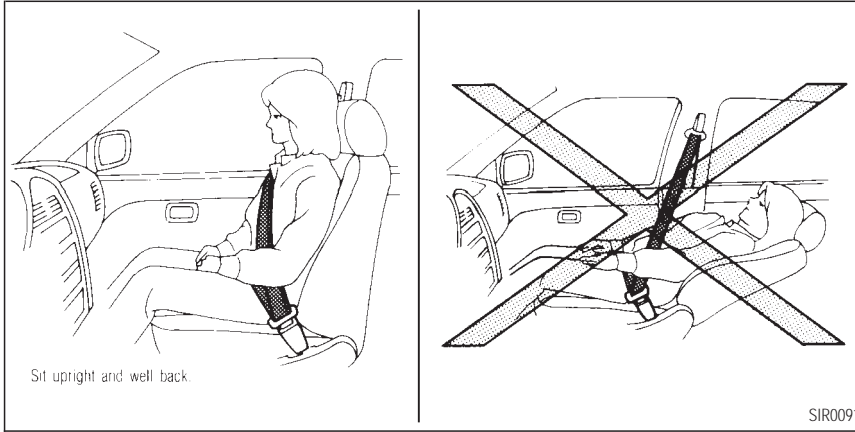

WARNING

- Do not ride in a moving vehicle when the seatback is reclined.

This can be dangerous. The shoulder belt will not be against your body. In an accident you could be thrown into it and receive neck or

other serious injuries. You could also slide under the lap belt and receive serious internal injuries.

- *For most effective protection when the vehicle is in motion, the seat should be upright. Always sit well back in the seat and adjust the seat belt properly. See "Precautions on seat belt usage" later in this section for precautions on seat belt usage.*

See "Automatic seat positioner" in the "3. Pre-driving checks and adjustments" for automatic seat positioner operation.

SEATS, RESTRAINTS AND SUPPLEMENTAL AIR BAG SYSTEMS

FRONT POWER SEAT ADJUSTMENT

WARNING

- Do not adjust the driver's seat while driving so full attention may be given to vehicle operation.
- Do not leave children unattended inside the vehicle. They could unknowingly activate switches or controls which could cause a serious accident.

Operating tips

- The motor has an auto-reset overload protection circuit. If the motor stops during operation, wait 30 seconds, then reactivate the switch.
- Do not operate the power seat for a long period of time when the engine is off. This

will discharge the battery.

Forward and backward

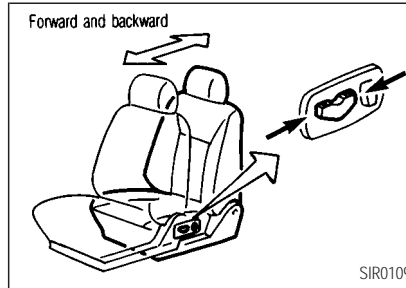

Moving the switch forward or backward will slide the seat forward or backward to the desired position.

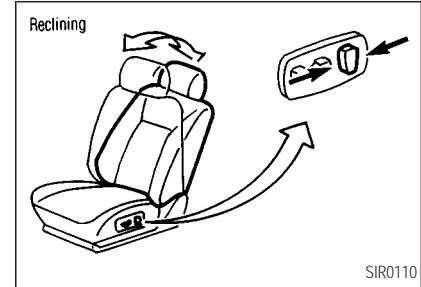

Reclining

Moving the recline switch forward or backward will move the seatback forward or backward to the desired position.

SEATS, RESTRAINTS AND SUPPLEMENTAL AIR BAG SYSTEMS

Seat lifter

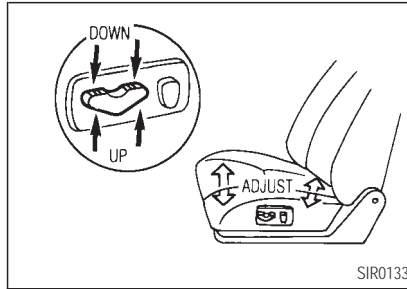

Push the front or rear end of the switch to adjust the angle and height of the seat cushion.

Lumbar support (if so equipped for driver's seat)

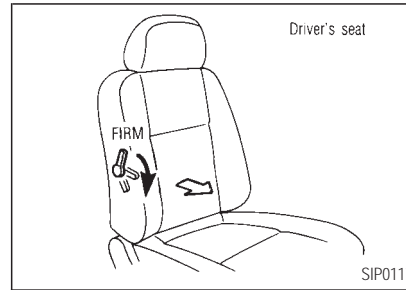

The lumbar support feature provides lower back support to the driver. Move the lever up or down to adjust the seat lumbar area.

REAR SEAT ADJUSTMENT

Before folding down the seat, put the buckle in its storage area in the seatback to avoid dropping it under the seat cushion.

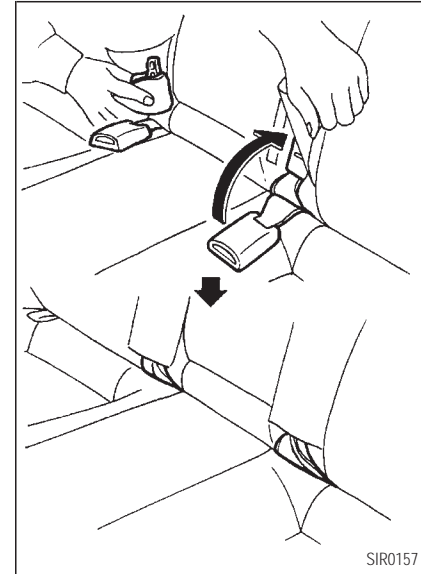

Folding

1. Remove the head restraints.

SEATS, RESTRAINTS AND SUPPLEMENTAL AIR BAG SYSTEMS

2. Pull the strap forward and fold the seat cushion up.
3. Pull the lever and pull the seat back forward to fold it down.
4. When resetting the seat, be sure to install the head restraints.

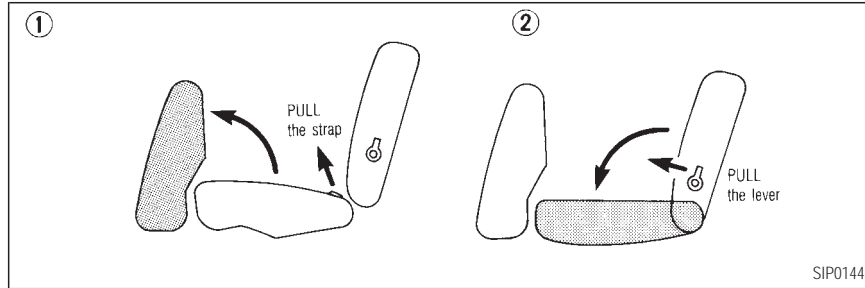

WARNING

- *Never allow anyone to ride in the cargo area or on the rear seat when it is in the fold-down position. Use of these areas by passengers without proper restraints could result in serious injury in an accident or sudden stop.*
- *It is extremely dangerous to ride*

in a cargo area inside of a vehicle. In a collision, people riding in these areas are more likely to be seriously injured or killed.

- *Do not allow people to ride in any area of your vehicle that is not equipped with seats and seat belts. Be sure everyone in your vehicle is in a seat and using a seat belt properly.*

SEATS, RESTRAINTS AND SUPPLEMENTAL AIR BAG SYSTEMS

- *Head restraints should be adjusted properly as they may provide significant protection against injury in an accident. Always replace and adjust them properly if they have been removed for any reason.*
- *If the head restraints are removed for any reason, they should be securely stored to prevent them from causing injury to passengers or damage to the vehicle in case of sudden braking or an accident.*
- *Properly secure all cargo to help prevent it from sliding or shifting. Do not place cargo higher than the seatbacks. In a sudden stop or collision, unsecured cargo could cause personal injury.*

- *When returning the seatbacks to the upright position, be certain they are completely secured in the latched position. If they are not completely secured in the right position, passengers may be injured in an accident or sudden stop.*

Reclining

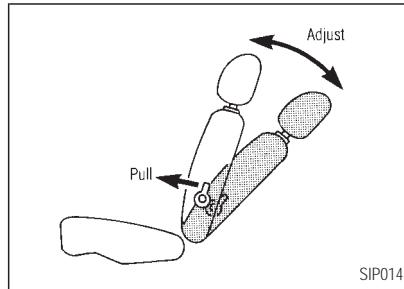

Pull the reclining lever and position the

seatback at the desired angle. Release the reclining lever after positioning the seatback at the desired angle.



WARNING

- *Do not ride in a moving vehicle when the seatback is reclined. This can be dangerous. The shoulder belt will not be against your body. In an accident you could be thrown into it and receive neck or other serious injuries. You could also slide under the lap belt and receive serious internal injuries.*
- *For most effective protection when the vehicle is in motion, the seat should be upright. Always sit well back in the seat and adjust the seat belt properly. See "Seat belts" later in this section for*

SEATS, RESTRAINTS AND SUPPLEMENTAL AIR BAG SYSTEMS

precautions on seat belt usage.

- *After adjustment, check to be sure the seat is securely locked.*

HEAD RESTRAINT ADJUSTMENT



WARNING

Head restraints should be adjusted properly as they may provide significant protection against injury in an accident. Do not remove them. Check the adjustment after someone else uses the seat.

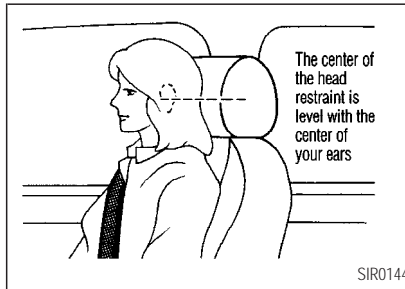
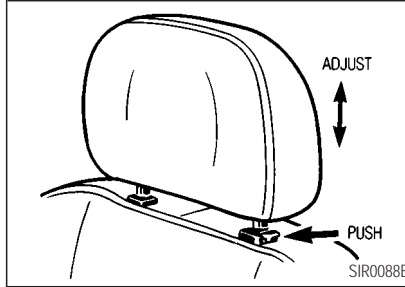

Adjust the head restraints so the center is level with the center of your ears.

To raise the head restraint, just pull it up. To lower, push the lock knob and push the head restraint down.

ACTIVE HEAD RESTRAINT (For front seats)

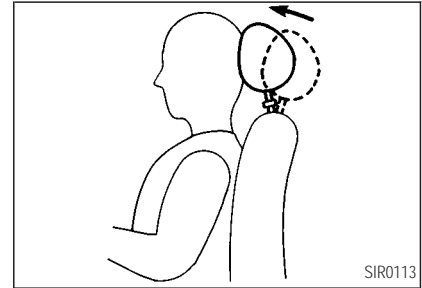

WARNING

- *Always adjust the head restraints properly as specified in the previ-*

SEATS, RESTRAINTS AND SUPPLEMENTAL AIR BAG SYSTEMS

ous section. Failure to do so can reduce the effectiveness of the active head restraint.

- **Active head restraints are designed to supplement other safety systems. Always wear seat belts. No system can prevent all injuries in any accident.**
- **Do not attach anything to the head restraint stalks. Doing so could impair active head restraint function.**

The head restraint moves forward utilizing the force that the seatback receives from the occupant in a rear-end collision. The movement of the head restraint helps support the occupant's head by reducing its backward movement and helping absorb some of the forces that may lead to whiplash type injuries.

Active head restraints are effective for collisions at low to medium speeds in which it is said that whiplash injury occurs most.

Active head restraints operate only in certain rear-end collisions. After the collision, the head restraints return to their original positions.

Properly adjust the active head restraints as described in the previous section.

ARMREST

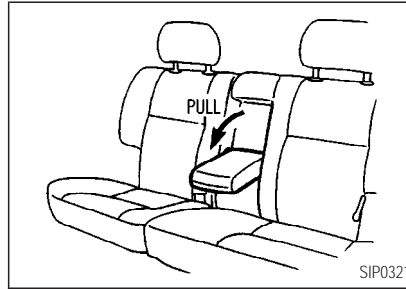

Pull the armrest forward and lay it horizontal.

SUPPLEMENTAL RESTRAINT SYSTEM

PRECAUTIONS ON SUPPLEMENTAL RESTRAINT SYSTEM

This Supplemental Restraint System (SRS) section contains important information concerning the driver and front passenger supplemental front air bags, supplemental side air bags and pre-tensioner seat belts.

Supplemental front air bag system: This system can help cushion the impact force to the face and chest of the driver and front passenger in certain frontal collisions.

Supplemental side air bag system: This system can help cushion the impact force to the head and chest area of the driver and front passenger in certain side impact collisions. The supplemental side air bag is designed to inflate on the side where the vehicle is impacted.

These supplemental restraint systems are de-

SEATS, RESTRAINTS AND SUPPLEMENTAL AIR BAG SYSTEMS

signed to **supplement** the crash protection provided by the driver and front passenger seat belts and are **not a substitute** for them. Seat belts should always be correctly worn and the driver and front passenger seated a suitable distance away from the steering wheel, instrument panel and front door finishers. (See "Seat belts" later in this section for instructions and precautions on seat belt usage.)

After turning the ignition key to the ON position, the supplemental air bag warning light illuminates. The supplemental air bag warning light will turn off after about 7 seconds if the systems are operational.

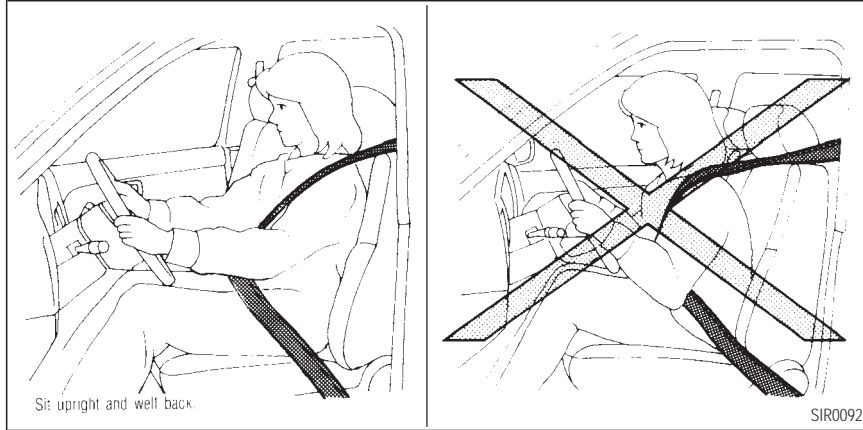

WARNING

- *The supplemental front air bags ordinarily will not inflate in the event of a side impact, rear im-*

pact, roll over, or lower severity frontal collision. Always wear your seat belts to help reduce the risk or severity of injury in various kinds of accidents.

SEATS, RESTRAINTS AND SUPPLEMENTAL AIR BAG SYSTEMS

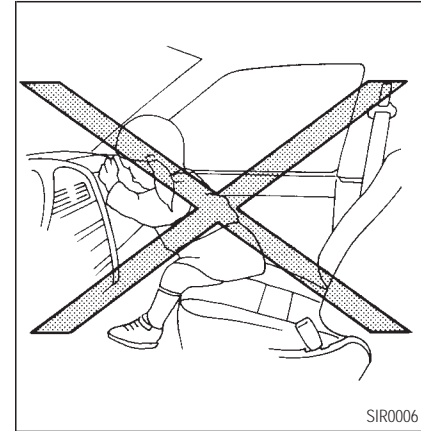
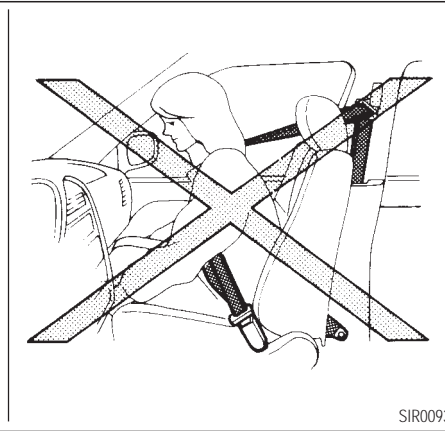

- *The seat belts and the supplemental front air bags are most effective when you are sitting well back and upright in the seat. Front air bags inflate with*

great force. If you are unrestrained, leaning forward, sitting sideways or out of position in any way, you are at greater risk of injury or death in a crash and may

also receive serious or fatal injuries from the supplemental front air bag if you are up against it when it inflates. Always sit back against the seatback and as far

SEATS, RESTRAINTS AND SUPPLEMENTAL AIR BAG SYSTEMS

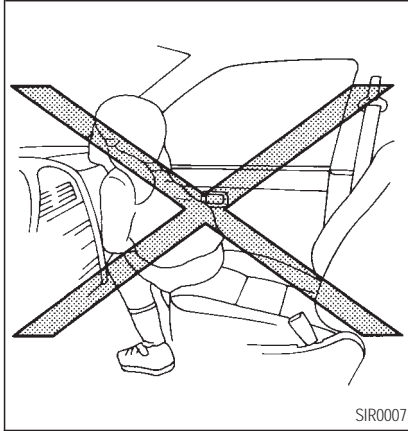

away as practical from the steering wheel or instrument panel. Always use the seat belts.

- *Keep hands on the outside of the steering wheel. Placing them in-*

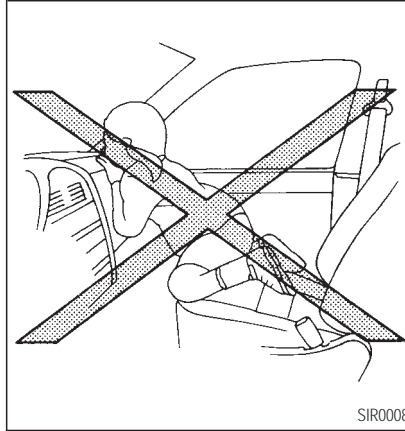

side the steering wheel rim could increase the risk that they are injured when the supplemental front air bag inflates.

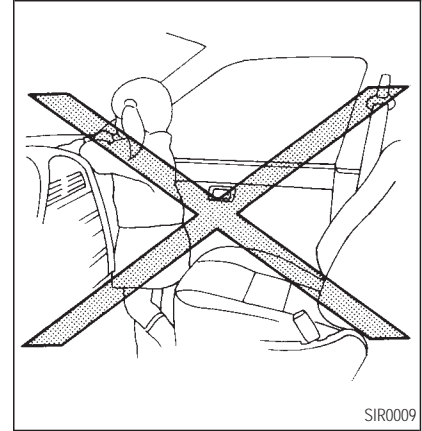

SEATS, RESTRAINTS AND SUPPLEMENTAL AIR BAG SYSTEMS

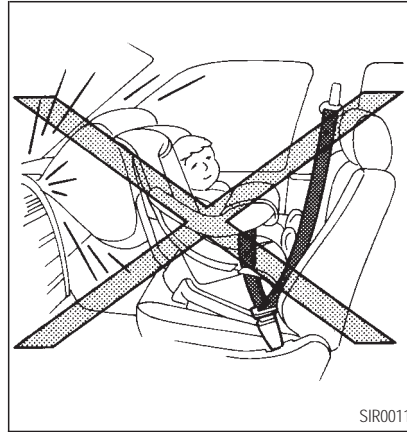
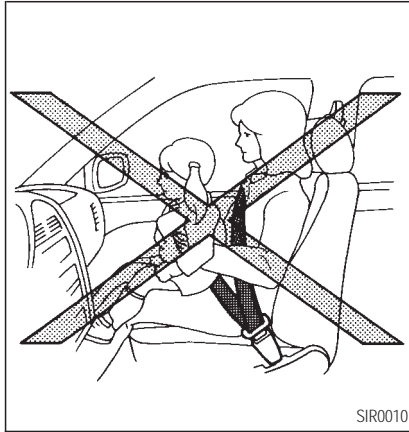

WARNING

- *Never let children ride unrestrained or extend their hands or face out of the window. Do not attempt to hold them in your lap or arms. Some examples of dangerous riding positions are shown in the previous illustrations.*
- *Children may be severely injured or killed when the supplemental front air bag or supplemental side air bag inflates if they are not properly restrained. Preteens and children should be properly restrained in the rear seat if possible.*
- *Never install a rear facing child restraint in the front seat. An*

SEATS, RESTRAINTS AND SUPPLEMENTAL AIR BAG SYSTEMS

inflating supplemental front air bag could seriously injure or kill your child. See "Child restraints" later in this section for details.

For supplemental side air bag system :

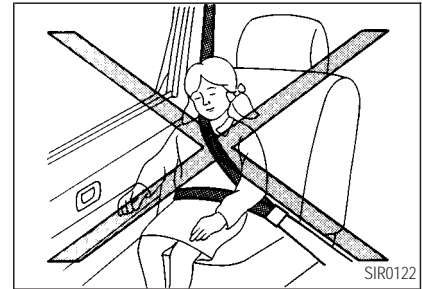
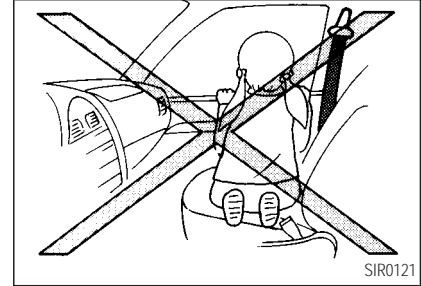
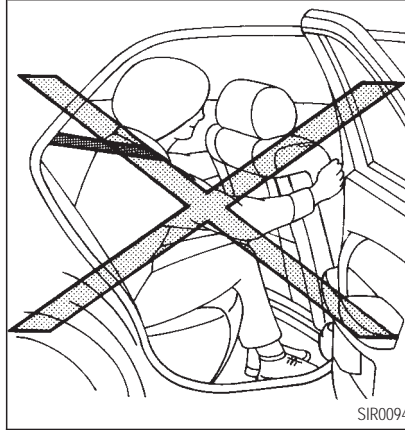
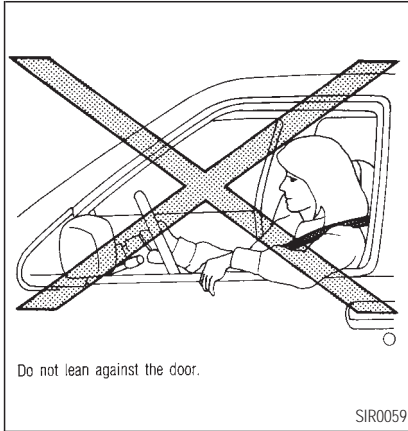

SEATS, RESTRAINTS AND SUPPLEMENTAL AIR BAG SYSTEMS



WARNING

- *The supplemental side air bag ordinarily will not inflate in the event of a frontal impact, rear impact or lower severity side collision. Always wear your seat belts to help reduce the risk or severity of injury in various kinds of accidents.*
- *The seat belts and the supplemental side air bag are most effective when you are sitting well back and upright in the seat. Supplemental side air bag inflates with great force. Do not allow anyone to place their hand, leg or face near the supplemental side air bag on the side of the seatback of the front seat. Do not allow anyone sitting in the front*

seat to extend their hand out of the window or lean against the door. Some examples of dangerous riding positions are shown in the previous illustrations.

When sitting in the rear seat, do not hold onto the seatback of the front seat. If the side air bag inflates, you may be seriously injured. Be especially careful with children, who should always be properly restrained.

- *Do not use seat covers on the front seatbacks. They may interfere with side air bag inflation.*

SEATS, RESTRAINTS AND SUPPLEMENTAL AIR BAG SYSTEMS

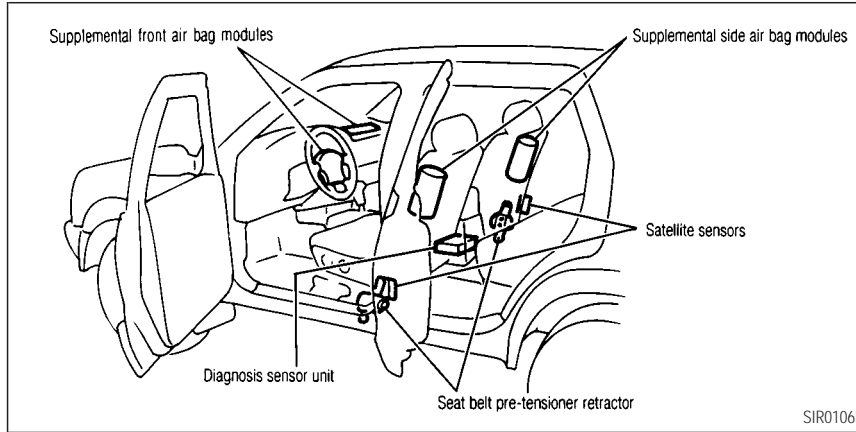

Supplemental front air bag system

The driver supplemental air bag is located in the center of the steering wheel; the front passenger supplemental air bag is mounted in the dashboard above the glove box. These systems are designed to meet optional certi-

fication requirements under U.S. regulations. They are also permitted in Canada. The optional certification allows front air bags to be designed to inflate somewhat less forcefully than previously. **However, all of the information, cautions and warnings in this manual still apply and must be followed.** The front air bags are designed to

inflate in higher severity frontal collisions, although they may inflate if the forces in another type of collision are similar to those of a higher severity frontal impact. They may not inflate in certain frontal collisions. Vehicle damage (or lack of it) is not always an indication of proper supplemental air bag operation.

When the supplemental front air bag inflates, a fairly loud noise may be heard, followed by release of smoke. This smoke is not harmful and does not indicate a fire, but care should be taken not to inhale it, as it may cause irritation and choking. Those with a history of breathing condition should get fresh air promptly.

Supplemental front air bags, along with the use of seat belts, help to cushion the impact force on the face and chest of the occupants. They can help save lives and reduce serious injuries. However, an inflating front air bag may cause facial abrasions or other injuries. Front air bags do not provide restraint to the

SEATS, RESTRAINTS AND SUPPLEMENTAL AIR BAG SYSTEMS

lower body.

The seat belts should be correctly worn and the driver and passenger seated upright as far as practical away from the steering wheel or dash board. Since the supplemental front air bags inflate quickly in order to help protect the front occupants, the force of the front air bag inflating can increase the risk of injury if the occupant is too close to or is against the air bag module during inflation. The air bag will deflate quickly after the collision is over.

After turning the ignition key to the ON position, the supplemental air bag warning light illuminates. The air bag warning light will turn off after about 7 seconds if the system is operational.



WARNING

- Do not place any objects on the steering wheel pad or on the instrument panel. Also, do not

place any objects between any occupant and the steering wheel or instrument panel. Such objects may become dangerous projectiles and may cause injury if the supplemental air bag inflates.

- *Right after inflation, several air bag system components will be hot. Do not touch them; you may severely burn yourself.*
- *No unauthorized changes should be made to any components or wiring of the supplemental front air bag system. This is to prevent accidental inflation of the supplemental air bags or damage to the supplemental air bag system.*
- *Do not make unauthorized changes to your vehicle's electrical system, suspension system or*

front end structure. This could affect proper operation of the supplemental front air bag system.

- *Tampering with the supplemental front air bag system may result in serious personal injury. Tampering includes changes to the steering wheel and the instrument panel assembly by placing material over the steering wheel pad and above the instrument panel, or by installing additional trim material around the air bag system.*
- *Work around and on the supplemental front air bag system should be done by an authorized INFINITI retailer. Installation of electrical equipment should also*

SEATS, RESTRAINTS AND SUPPLEMENTAL AIR BAG SYSTEMS

be done by an authorized INFINITI retailer. The yellow Supplemental Restraint System (SRS) wiring harnesses should not be modified or disconnected. Unauthorized electrical test equipment and probing devices should not be used on the air bag system.*

- *A cracked windshield should be replaced immediately by a qualified repair facility. A cracked windshield could affect inflation of the supplemental air bag system.*
- * *The SRS wiring harnesses are covered with yellow insulation either just before the harness connectors or over the complete harness for easy identification.*

When selling your vehicle, we request that you

inform the buyer about the supplemental air bag system and guide the buyer to the appropriate sections in this Owner's Manual.

Supplemental side air bag system

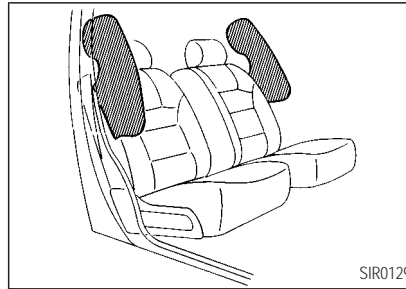

The supplemental side air bags are located in the outside of the seatback of the front seats. The supplemental side air bag (on the driver or front passenger seat) is designed to inflate in higher severity side collisions, although it may inflate if the forces in another type of collision are similar to those of a higher severity side impact. It is designed to inflate

on the side where the vehicle is impacted. It may not inflate in certain side collisions. Vehicle damage (or lack of it) is not always an indication of proper supplemental side air bag operation.

When the supplemental side air bag inflates, a fairly loud noise may be heard, followed by release of smoke. This smoke is not harmful and does not indicate a fire, but care should be taken not to inhale it, as it may cause irritation and choking. Those with a history of a breathing condition should get fresh air promptly.

Supplemental side air bags along with the use of seat belts, help to cushion the impact force on the head and chest of the front occupants. They can help save lives and reduce serious injuries. However, an inflating side air bag may cause abrasions or other injuries. Side air bags do not provide restraint to the lower body.

The seat belts should be correctly worn and the driver and passenger seated upright as far

SEATS, RESTRAINTS AND SUPPLEMENTAL AIR BAG SYSTEMS

as practical away from the supplemental side air bag. Since the side air bags inflate quickly in order to help protect the front occupants, the force of the side air bag inflating can increase the risk of injury if the occupant is too close to or is against the side air bag module during inflation. The side air bag will deflate quickly after the collision is over.

After turning the ignition key to the ON position, the supplemental air bag warning light illuminates. The air bag warning light will turn off after about 7 seconds if the system is operational.



WARNING

- *Do not place any objects near the seatback of the front seats. Also, do not place any objects (an umbrella, bag, etc.) between the front door finisher and the front seat. Such objects may become*

dangerous projectiles and cause injury if the supplemental side air bag inflates.

- *Right after inflation, several side air bag system components will be hot. Do not touch them; you may severely burn yourself.*
- *No unauthorized changes should be made to any components or wiring of the side air bag system. This is to prevent accidental inflation of the side air bags or damage to the side air bag system.*
- *Do not make unauthorized changes to your vehicle's electrical system, suspension system or side panel. This could affect proper operation of the side air bag system.*

- *Tampering with the side air bag system may result in serious personal injury. Tampering includes changes to the front seats assembly by placing material near the seatback of the front seat, or by installing additional trim material, such as seat covers, around the side air bag system.*
- *Work around and on the supplemental side air bag system should be done by an authorized INFINITI retailer. Installation of electrical equipment should also be done by an authorized INFINITI retailer. The SRS wiring harnesses* should not be modified or disconnected. Unauthorized electrical test equipment and probing devices should not be used on the side air bag system.*

SEATS, RESTRAINTS AND SUPPLEMENTAL AIR BAG SYSTEMS

* *The SRS wiring harnesses are covered with yellow insulation either just before the harness connectors or over the complete harness for easy identification.*

When selling your vehicle, we request that you inform the buyer about the supplemental side air bag system and guide the buyer to the appropriate sections in this Owner's Manual.

Pre-tensioner seat belt system (For front seats)



WARNING

- *The pre-tensioner seat belt cannot be reused after activation. It must be replaced together with the retractor as a unit.*
- *If the vehicle becomes involved in*

a frontal collision but the pre-tensioner is not activated, be sure to have the pre-tensioner system checked and, if necessary, replaced by your INFINITI retailer.

- *No unauthorized changes should be made to any components or wiring of the pre-tensioner seat belt system. This is to prevent accidental activation of the pre-tensioner seat belt or damage to the pre-tensioner seat belt operation. Tampering with the pre-tensioner seat belt system may result in serious personal injury.*
- *Work around and on the pre-tensioner system should be done by an authorized INFINITI retailer. Installation of electrical equipment should also be done*

by an authorized INFINITI retailer. Unauthorized electrical test equipment and probing devices should not be used on the pre-tensioner seat belt system.

- *If you need to dispose of the pre-tensioner or scrap the vehicle, contact an authorized INFINITI retailer. Correct pre-tensioner disposal procedures are set forth in the appropriate INFINITI Service Manual. Incorrect disposal procedures could cause personal injury.*

The front seat pre-tensioner seat belt system activates in conjunction with the supplemental front air bag. Working with the seat belt retractor, it helps tighten the seat belt the instant the vehicle becomes involved in certain types of collisions, thereby restraining seat occupants.

SEATS, RESTRAINTS AND SUPPLEMENTAL AIR BAG SYSTEMS

The pre-tensioner is encased with the seat belt's retractor. These seat belts are used the same as conventional seat belts.

When the pre-tensioner seat belt activates, smoke is released and a loud noise may be heard. The smoke is not harmful, but care should be taken not to inhale it as it may cause irritation and choking. Those with a history of a breathing condition should get fresh air promptly.

If any abnormality occurs in the pre-tensioner system, the supplemental air bag warning light  will not come on, will flash intermittently or will turn on for 7 seconds and remain on after the ignition key has been turned to the ON or START position. In this case, the pre-tensioner seat belt may not function properly. The system should be inspected by an authorized INFINITI retailer.

When selling your vehicle, we request that you inform the buyer about the pre-tensioner seat

belt system and guide the buyer to the appropriate sections in this Owner's Manual.

SEATS, RESTRAINTS AND SUPPLEMENTAL AIR BAG SYSTEMS

SUPPLEMENTAL AIR BAG WARNING LABELS

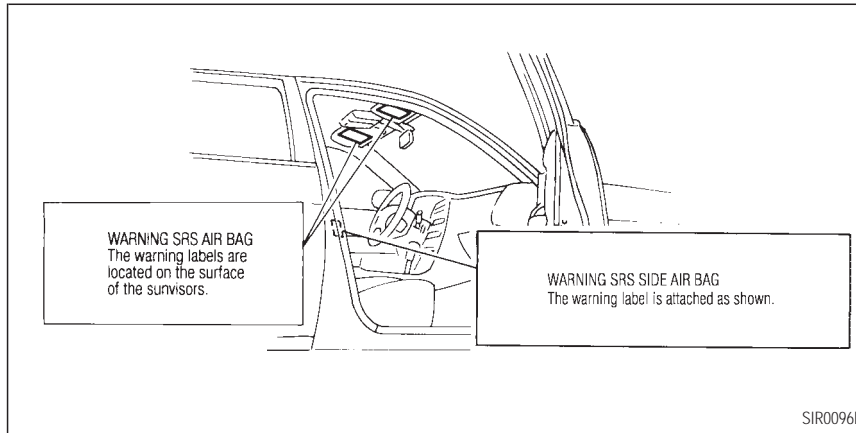

The warning labels about the supplemental air bag system and supplemental side air bag system are placed in the vehicle.

SUPPLEMENTAL AIR BAG WARNING LIGHT



The supplemental air bag warning light, displaying  in the instrument panel, monitors the circuits of the supplemental front air bag and supplemental side air bag systems and pre-tensioner seat belt. The circuits monitored by the air bag warning light are the diagnosis sensor unit, satellite sensors, front air bag modules, side air bag modules, pre-tensioner seat belt and all related wiring.

After turning the ignition key to the ON

SEATS, RESTRAINTS AND SUPPLEMENTAL AIR BAG SYSTEMS

position, the supplemental air bag warning light illuminates. The supplemental air bag warning light will turn off after about 7 seconds if the system is operational.

If any of the following conditions occur, the supplemental front air bag and supplemental side air bag systems and pre-tensioner seat belt need servicing:

- The supplemental air bag warning light remains on after approximately 7 seconds.
- The supplemental air bag warning light flashes intermittently.
- The supplemental air bag warning light does not come on at all.

Under these conditions, the supplemental front air bags, supplemental side air bags and/or pre-tensioner seat belt may not operate properly. They must be checked and repaired. Take your vehicle to the nearest authorized INFINITI retailer.



WARNING

If the supplemental air bag warning light is on, it could mean that the supplemental front air bag system, supplemental side air bag system and/or pre-tensioner seat belt will not operate in an accident.

Repair and replacement procedure

The supplemental front air bags or supplemental side air bags are designed to inflate on a one-time-only basis. As a reminder, unless it is damaged, the supplemental air bag warning light will remain illuminated after inflation has occurred. Repair and replacement of these supplemental systems should be done only by authorized INFINITI retailers.

When maintenance work is required on the

vehicle, the supplemental front air bags, supplemental side air bags and related parts should be pointed out to the person conducting the maintenance. The ignition key should always be in the LOCK position when working under the hood or inside the vehicle.



WARNING

- ***Once the supplemental front air bag or supplemental side air bag and/or pre-tensioner seat belt have activated, the front air bag module will not function again and must be replaced, additionally, if any of the supplemental air bags inflate, the pre-tensioner seat belts must also be replaced. The air bag module should be replaced by an authorized INFINITI retailer. The air bag module cannot be repaired.***

SEATS, RESTRAINTS AND SUPPLEMENTAL AIR BAG SYSTEMS

SEAT BELTS

- *The supplemental front air bag and supplemental side air bag system should be inspected by an authorized INFINITI retailer if there is any damage to the front or side end portion of the vehicle or replaced if the supplemental air bag has inflated.*
- *If you need to dispose of these supplemental systems or scrap the vehicle, contact an authorized INFINITI retailer.*

Correct disposal procedures are set forth in the appropriate INFINITI Service Manual. Incorrect disposal procedures could cause personal injury.

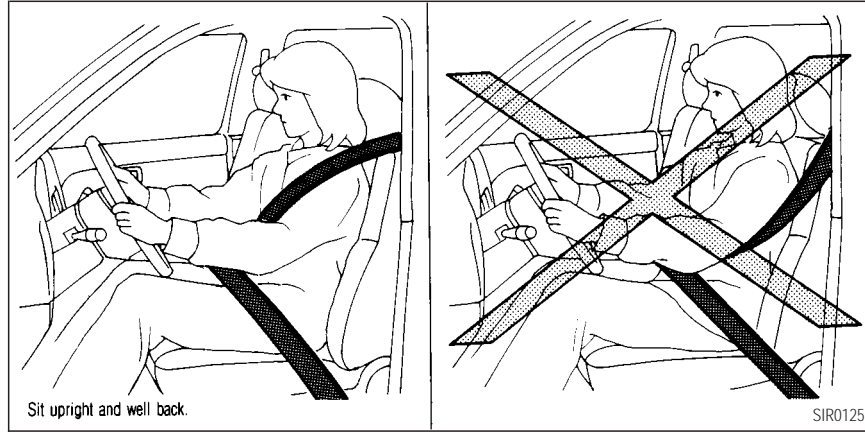

PRECAUTIONS ON SEAT BELT USAGE

Your chances of being injured or killed in an accident and/or the severity of injury may be greatly reduced if you are wearing your seat belt and it is properly adjusted. INFINITI

strongly encourages you and all of your passengers to buckle up every time you drive, even if your seating position includes a supplemental air bag.

SEATS, RESTRAINTS AND SUPPLEMENTAL AIR BAG SYSTEMS

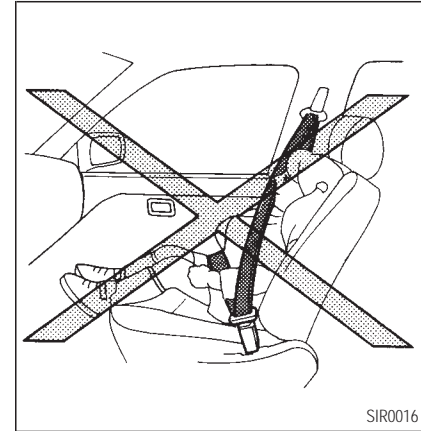
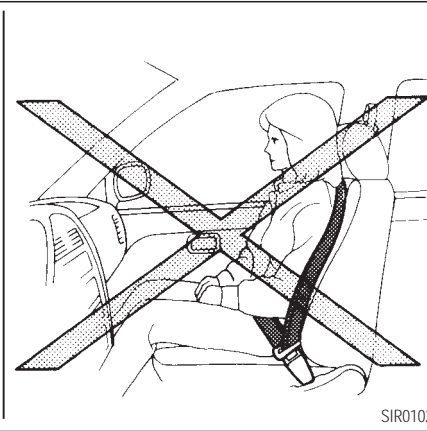
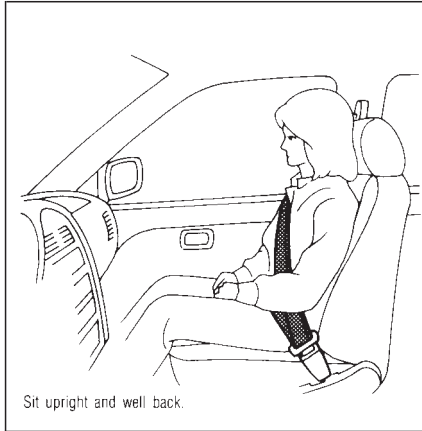

Most states, provinces or territories require that seat belts be worn at all times when a vehicle is being driven.



WARNING

- Every person who drives or rides

in this vehicle should use a seat belt at all times. Children should be properly restrained in the rear seat and, if appropriate, in a child restraint.

- *The belt should be properly adjusted to a snug fit. Failure to do so may reduce the effectiveness of the entire restraint system and increase the chance or severity of*

SEATS, RESTRAINTS AND SUPPLEMENTAL AIR BAG SYSTEMS

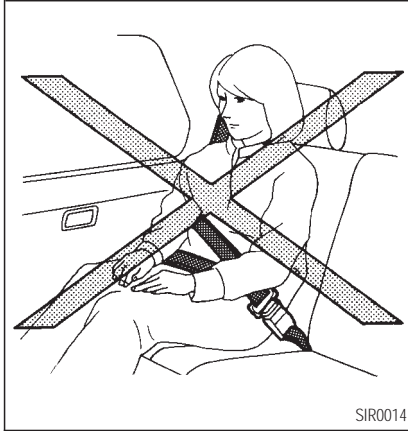

injury in an accident. Serious injury or death can occur if the seat belt is not worn properly.

- Always route the shoulder belt over your shoulder and across

your chest. Never run the belt under your arm or across your neck. The belt should be away from your face and neck, but not falling off your shoulder.

- Position the lap belt as low and snug as possible around the hips, not the waist. A lap belt worn too high could increase the risk of internal injuries in an accident.
- Be sure the seat belt tongue is securely fastened to the proper buckle.
- Do not wear the belt inside out or twisted. Doing so may reduce its effectiveness.
- Do not allow more than one person to use the same belt.

- Never carry more people in the vehicle than there are seat belts.
- If the seat belt warning light glows continuously while the ignition is turned ON with all doors closed and all seat belts fastened, it may indicate a malfunction in the system. Have the system checked by your INFINITI retailer.
- Once the pre-tensioner seat belt has activated, it cannot be reused and must be replaced together with the retractor. See your INFINITI retailer.
- Removal and installation of the pre-tensioner seat belt system components should be done by an authorized INFINITI retailer.

SEATS, RESTRAINTS AND SUPPLEMENTAL AIR BAG SYSTEMS

- *All seat belt assemblies including retractors and attaching hardware should be inspected after any collision by your INFINITI retailer. INFINITI recommends that all seat belt assemblies in use during a collision be replaced unless the collision was minor and the belts show no damage and continue to operate properly. Seat belt assemblies not in use during a collision should also be inspected and replaced if either damage or improper operation is noted.*
- *All child restraints and attaching hardware should be inspected after any collision. Always follow the restraint manufacturer's inspection instructions and replacement recommendations. The*

child restraints should be replaced if they are damaged.

CHILD SAFETY

Children need adults to help protect them. They need to be properly restrained.

The proper restraint depends on the child's size. Generally, infants [up to about 1 year and less than 20 lbs. (9 kg)] should be placed in rear facing child restraints. Front facing child restraints are available for children who outgrow rear facing child restraints.



WARNING

Infants and children need special protection. The vehicle's seat belts may not fit them properly. The shoul-

der belt may come too close to the face or neck. The lap belt may not fit over their small hip bones. In an accident, an improperly fitting seat belt could cause serious or fatal injury. Always use appropriate child restraints.

All US states and provinces of Canada require the use of approved child restraints for infants and small children. (See "Child restraints" later in this section.)

In addition, there are many types of child restraints available for larger children which should be used for maximum protection.

INFINITI recommends that all preteens and children be restrained in the rear seat if possible. According to accident statistics, children are safer when properly restrained in the rear seat than in the front seat.

SEATS, RESTRAINTS AND SUPPLEMENTAL AIR BAG SYSTEMS

This is especially important because your vehicle has a supplemental restraint system (Air bag system) for the front passenger. See “Supplemental restraint system” earlier in this section for precautions.

Infants and small children

INFINITI recommends that infants and small children be placed in child restraints that comply with Federal Motor Vehicle Safety Standards or Canadian Motor Vehicle Safety Standards. You should choose a child restraint that fits your vehicle and always follow the manufacturer’s instructions for installation and use.

Larger children

Children who are too large for child restraints should be seated and restrained by the seat belts which are provided.

If the child’s seating position has a shoulder belt that fits close to the face or neck, the use

of a booster seat (commercially available) may help overcome this. The booster seat should raise the child so that the shoulder belt is properly positioned across the top, middle portion of the shoulder and the lap belt is low on the hips. The booster seat should fit the vehicle seat and have a label certifying that it complies with Federal Motor Vehicle Safety Standards or Canadian Motor Vehicle Safety Standards. Once the child has grown so the shoulder belt is no longer on or near the face and neck, use the shoulder belt without the booster seat.



WARNING

Never let a child stand or kneel on any seat and do not allow a child in the cargo areas while the vehicle is moving. The child could be seriously injured or killed in an accident or

sudden stop.

PREGNANT WOMEN

INFINITI recommends that pregnant women use seat belts. The seat belt should be worn snug, and always position the lap belt as low as possible around the hips, not the waist, and place the shoulder belt over your shoulder and across your chest. Never run the lap/shoulder belt over your abdominal area. Contact your doctor for specific recommendations.

INJURED PERSONS

INFINITI recommends that injured persons use seat belts, depending on the injury. Check with your doctor for specific recommendations.

SEATS, RESTRAINTS AND SUPPLEMENTAL AIR BAG SYSTEMS

THREE-POINT TYPE SEAT BELT WITH RETRACTOR

WARNING

- Every person who drives or rides in this vehicle should use a seat belt at all times.
- Do not ride in a moving vehicle when the seatback is reclined. This can be dangerous. The shoulder belt will not be against your body. In an accident you could be thrown into it and receive neck or other serious injuries. You could also slide under the lap belt and receive serious internal injuries.
- For most effective protection when the vehicle is in motion, the

seat should be upright. Always sit well back in the seat and adjust the seat belt properly.

Fastening the seat belts

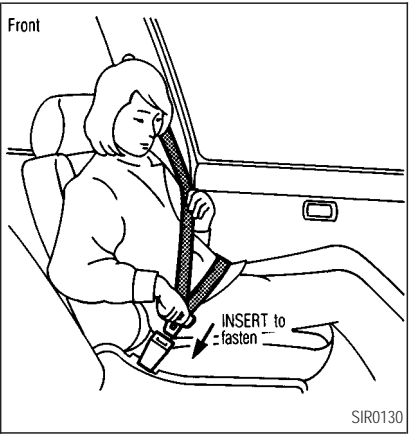

1. Adjust the seat.

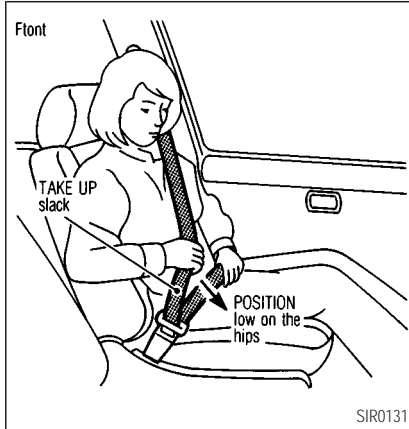

2. Slowly pull the seat belt out of the retractor and insert the tongue into the buckle until it snaps.

SEATS, RESTRAINTS AND SUPPLEMENTAL AIR BAG SYSTEMS



The retractor is designed to lock during a sudden stop or on impact. A slow pulling motion will permit the belt to move, and allow you some freedom of movement in the seat.

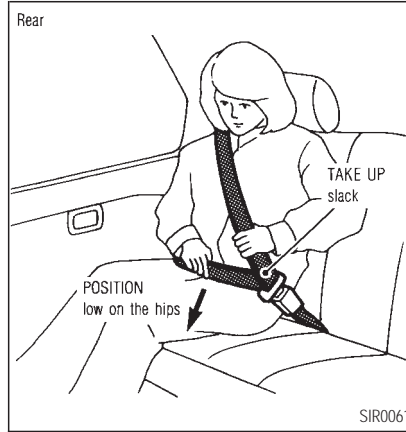

3. Position the lap belt portion **low and snug on the hips** as shown.
4. Pull the shoulder belt portion toward the retractor to take up extra slack.

The front passenger side seat belt and rear three-point seat belts have a cinching mechanism for child restraint installation. It is

referred to as the automatic locking mode. When the cinching mechanism is activated the seat belt cannot be withdrawn again until the seat belt tongue is detached from the buckle and fully retracted. For additional information see "Child Restraints" later in this section.

The automatic locking mode should be used **only** for child restraint installation. During normal seat belt use by a passenger, the locking mode should not be activated. If it is activated it may cause uncomfortable seat belt tension.



WARNING

When fastening the seat belts, be certain that seatbacks are completely secured in the latched position. If they are not completely secured in the right position, passengers may be injured in an accident or sudden

SEATS, RESTRAINTS AND SUPPLEMENTAL AIR BAG SYSTEMS

stop.

Unfastening the seat belts

To unfasten the belt, press the button on the buckle. The seat belt will automatically retract.

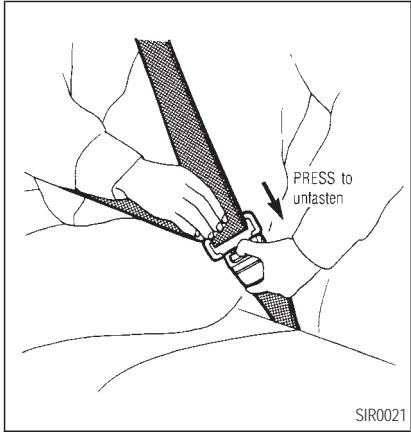

Checking seat belt operation

Your seat belt retractors are designed to lock belt movement by two separate methods:

- When the belt is pulled quickly from the retractor.
- When the vehicle slows down rapidly.

You can check their operation as follows:

- Grasp the shoulder belt and pull quickly forward. The retractor should lock and restrict further belt movement.

If the retractor does not lock during this check or if you have any question about belt operation, see your INFINITI retailer.

Shoulder belt height adjustment (For front seats)

The shoulder belt anchor height should be adjusted to the position best for you. See "Seat belts" for precautions on seat belt usage.

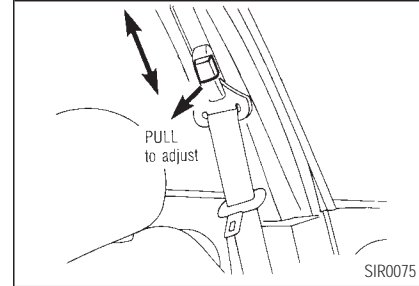

To adjust, pull the release buttons, and move the shoulder belt anchor to the desired position, so the belt passes over the center of the shoulder. The belt should be away from your face and neck, but not falling off of your shoulder. Release the adjustment buttons to lock the shoulder belt anchor into position.

! WARNING

- **After adjustment, release the ad-**

SEATS, RESTRAINTS AND SUPPLEMENTAL AIR BAG SYSTEMS

adjustment buttons and try to move the shoulder belt anchor up and down to make sure it is securely fixed in position.

- *The shoulder belt anchor height should be adjusted to the position best for you. Failure to do so may reduce the effectiveness of the entire restraint system and increase the chance or severity of injury in an accident.*

Seat belt hook

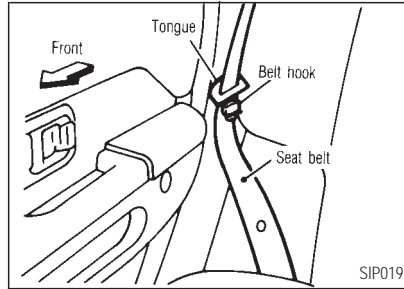

When the rear seat belt is not in use, hook it at the belt hook.

TWO-POINT TYPE SEAT BELT WITHOUT RETRACTOR (Center of rear seat)

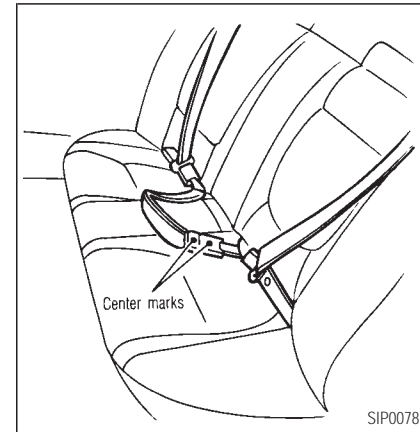

Selecting correct set of seat belts

The center seat belt buckle and tongue are identified by the "CENTER" mark. The center seat belt tongue can be fastened **only** into the

SEATS, RESTRAINTS AND SUPPLEMENTAL AIR BAG SYSTEMS

center seat belt buckle.

Fastening the seat belts



1. Insert the tongue into the buckle marked CENTER until it snaps.



2. To shorten, hold the tongue at a right angle to the belt and pull on the belt.

To shorten, pull the free end of the belt away from the tongue, then pull the belt clip to take up the slack.



SEATS, RESTRAINTS AND SUPPLEMENTAL AIR BAG SYSTEMS



3. Position the lap belt **low and snug on the hips** as illustrated.

Unfastening the seat belts

To unfasten the belt, press the button on the buckle.

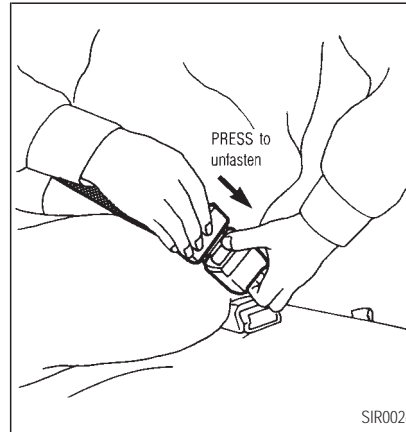

SEAT BELT EXTENDERS

If, because of body size or driving position, it is not possible to properly fit the lap-shoulder belt and fasten it, an extender is available which is compatible with the installed seat belts. The extender adds approximately 8 in (200 mm) of length and may be used for either the driver or front passenger seating position. See your INFINITI retailer for assistance if the extender is required.



WARNING

- *Only INFINITI belt extenders, made by the same company which made the original equipment belts, should be used with the INFINITI belts.*
- *Adults and children who can use the standard seat belt should not*

SEATS, RESTRAINTS AND SUPPLEMENTAL AIR BAG SYSTEMS

use an extender. Such unnecessary use could result in serious personal injury in the event of an accident.

- *Never use seat belt extenders to install child restraints. If the child restraint is not secured properly, the child could be seriously injured in a collision or a sudden stop.*

SEAT BELT MAINTENANCE

- To clean the seat belt webbings, apply a mild soap solution or any non-caustic solution recommended for gently cleaning cloth upholstery or carpets. Then brush it, wipe with a cloth and allow it to dry in the shade. Do not allow the seat belts to retract until they are completely dry.

- If dirt builds up in the shoulder belt guide of the seat belt anchors, the belts may retract slowly. Wipe the shoulder belt guide with a clean, dry cloth.
- Periodically check to see that the seat belt and the metal components such as buckles, tongues, retractors, flexible wires and anchors work properly. If loose parts, deterioration, cuts or other damage on the webbing are found, the entire belt assembly should be replaced.

CHILD RESTRAINTS

PRECAUTIONS ON CHILD RESTRAINTS



WARNING

- *Infants and small children should always be placed in an appropriate child restraint while riding in*

the vehicle. Failure to use a child restraint can result in serious injury or death.

- *Infants and small children should never be carried on your lap. It is not possible for even the strongest adult to resist the forces of a severe accident. The child could be crushed between the adult and parts of the vehicle. Also, do not put the same seat belt around both your child and yourself.*
- *Never install a rear facing child restraint in the front seat. An inflating supplemental front air bag could seriously injure or kill your child. A rear facing child restraint must only be used in the rear seat.*
- *INFINITI recommends that the*

SEATS, RESTRAINTS AND SUPPLEMENTAL AIR BAG SYSTEMS

child restraint be installed in the rear seat. According to accident statistics, children are safer when properly restrained in the rear seat than in the front seat.

- *An improperly installed child restraint could lead to serious injury or death in an accident.*

In general, child restraints are designed to be installed with a lap belt or the lap portion of a three point type seat belt. Child restraints for infants and children of various sizes are offered by several manufacturers. When selecting any child restraint system, keep the following points in mind:

- Choose only a restraint with a label certifying that it complies with Federal Motor Vehicle Safety Standard 213 or Canadian Motor Vehicle Safety Standard 213.

- Check the child restraint in your vehicle to be sure it is compatible with the vehicle's seat and seat belt system.
- If the child restraint is compatible with your vehicle, place your child in the child restraint and check the various adjustments to be sure the child restraint is compatible with your child. Always follow all recommended procedures.

All US states and Canadian provinces require that infants and small children be restrained in approved child restraint systems at all times while the vehicle is being operated.



WARNING

- *Improper use of a child restraint can result in increased injuries for both the infant or child and other*

occupants in the vehicle.

- *Follow all of the child restraint manufacturer's instructions for installation and use. When purchasing a child restraint, be sure to select one which will fit your child and vehicle. It may not be possible to properly install some types of child restraints in your vehicle.*
- *If the child restraint seat is not anchored properly, the risk of a child being injured in a collision or a sudden stop greatly increases.*
- *Adjustable seatbacks should be positioned to fit the child restraint, but as upright as possible.*

SEATS, RESTRAINTS AND SUPPLEMENTAL AIR BAG SYSTEMS

- *After attaching the child restraint, test it before you place the child in it. Tilt it from side to side. Try to tug it forward and check to see if the belt holds the restraint in place. If the restraint is not secure, tighten the belt as necessary, or put the restraint in another seat and test it again.*
- *For a front facing child restraint, if the seat position where it is installed has a three-point type lap/shoulder belt, check to make sure the shoulder belt does not go in front of the child's face or neck. If it does, put the shoulder belt behind the child restraint. If you must install a front facing child restraint in the front seat, see "Installation on front passenger seat" later in this section for*

details.

- *When your child restraint is not in use, store it in the trunk or keep it secured with a seat belt to prevent it from being thrown around in case of a sudden stop or accident.*



CAUTION

Remember that a child restraint left in a closed vehicle can become very hot. Check the seating surface and buckles before placing your child in the child restraint.

INSTALLATION ON REAR SEAT CENTER POSITION

Front facing

When you install a child restraint in a rear center seat, follow these steps:

SEATS, RESTRAINTS AND SUPPLEMENTAL AIR BAG SYSTEMS



1. Position the child restraint on the seat as illustrated. The direction of the child restraint depends on the type of the child restraint and the size of the child. Always follow the restraint manufacturer's instructions.

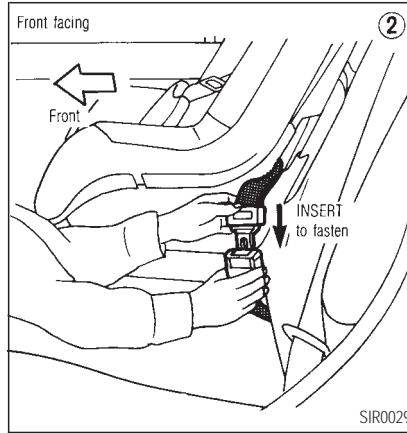

2. Route the seat belt tongue through the child restraint and insert it into the buckle until you hear and feel the latch engage. Be sure to follow the child restraint manufacturer's instructions for belt routing.

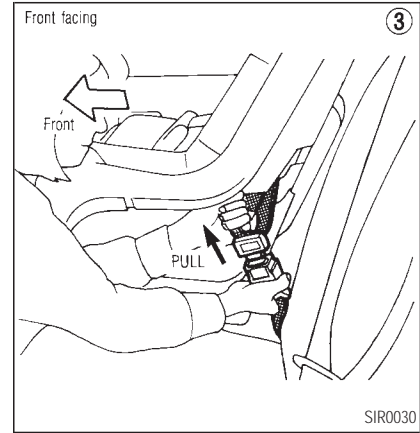

3. Remove all slack in the lap belt for a very tight fit by pulling forcefully on the lap belt adjustment.

SEATS, RESTRAINTS AND SUPPLEMENTAL AIR BAG SYSTEMS

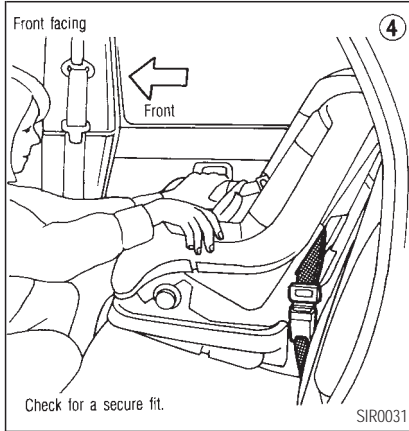

4. Before placing the child in the child restraint, use force to tilt the child restraint from side to side, and tug it forward to make sure it is securely held in place.
5. If it is not secure, try to tighten the belt again, or put the restraint in another seat.
6. Check to make sure the child restraint is

properly secured prior to each use.

Rear facing

When you install a child restraint in a rear center seat, follow these steps:

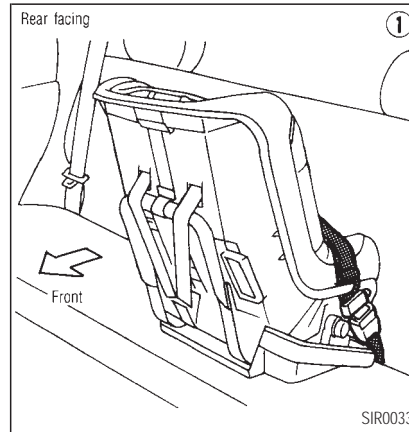

1. Position the child restraint on the seat as illustrated. The direction of the child restraint depends on the type of the child

restraint and the size of the child. Always follow the restraint manufacturer's instructions.

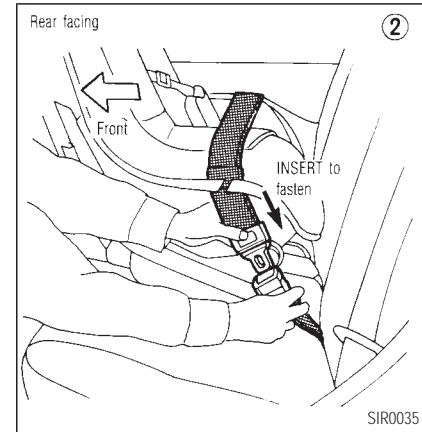

2. Route the seat belt tongue through the child restraint and insert it into the buckle until you hear and feel the latch engage. Be sure to follow the child restraint manufac-

SEATS, RESTRAINTS AND SUPPLEMENTAL AIR BAG SYSTEMS

turer's instructions for belt routing.

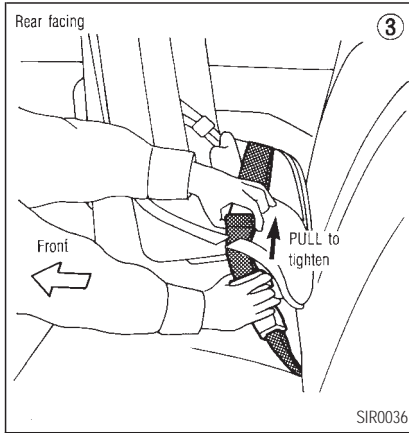

3. Remove all slack in the lap belt for a very tight fit by pulling forcefully on the lap belt adjustment.

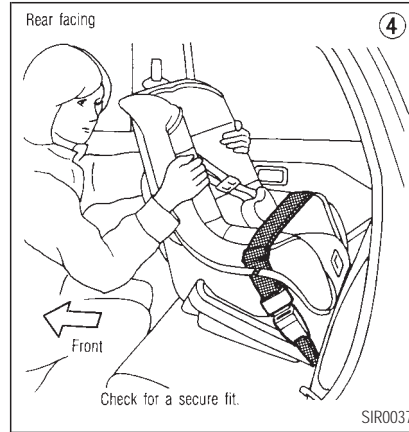

4. Before placing the child in the child restraint, use force to tilt the child restraint from side to side, and tug it forward to make sure that it is securely held in place.
5. If it is not secure, try to tighten the belt again, or put the restraint in another seat.
6. Check to make sure the child restraint is

properly secured prior to each use.

INSTALLATION ON REAR SEAT OUTBOARD POSITIONS

Front facing

WARNING

- *The three-point belt in your vehicle is equipped with a locking mode retractor which must be used when installing a child restraint.*
- *Failure to do so will result in the child restraint not being properly secured. It could tip over or otherwise be unsecured and cause injury to the child in a sudden stop or collision.*

When you install a child restraint in a rear outboard seat, follow these steps:

SEATS, RESTRAINTS AND SUPPLEMENTAL AIR BAG SYSTEMS

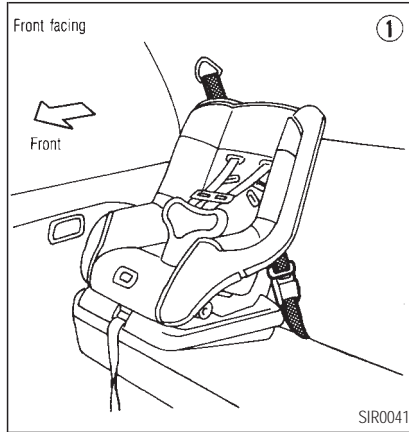

1. Position the child restraint on the seat. The direction of the child restraint depends on the type of the child restraint and the size of the child. Always follow the restraint manufacturer's instructions.

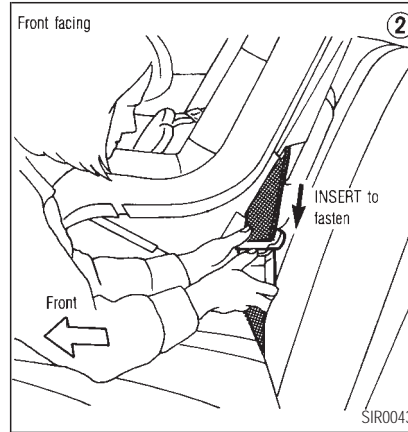

2. Route the seat belt tongue through the child restraint and insert it into the buckle until you hear and feel the latch engage. Be sure to follow the child restraint manufacturer's instructions for belt routing.

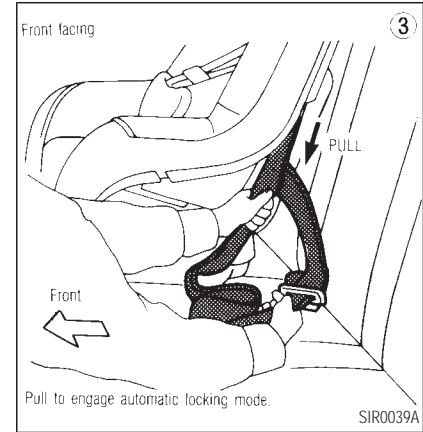

3. Pull on the shoulder belt until all of the belt is fully extended. At this time, the belt retractor is in the automatic locking mode (child restraint mode). It reverts back to emergency locking mode when the buckle is unlatched and the belt is allowed to fully retract.

SEATS, RESTRAINTS AND SUPPLEMENTAL AIR BAG SYSTEMS

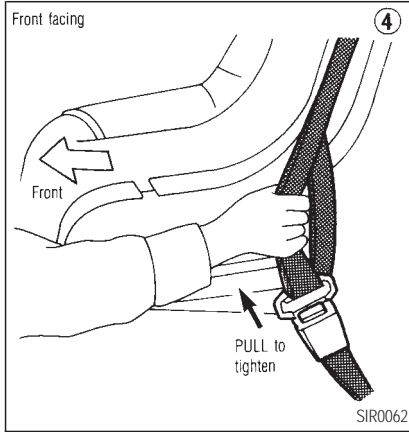

4. Allow the belt to retract. Pull up on the belt to remove any slack in the belt.

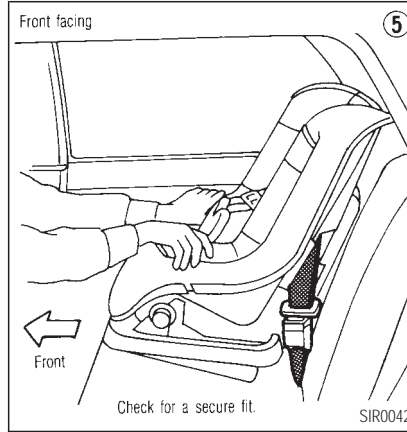

5. Before placing the child in the child restraint, use force to tilt the child restraint from side to side, and tug it forward to make sure that it is securely held in place.
6. Check that the retractor is in the automatic locking mode by trying to pull more belt out of the retractor. If you cannot pull any

more belt webbing out of the retractor, the belt is in the automatic locking mode.

7. Check to make sure the child restraint is properly secured prior to each use. If the belt is not locked, repeat steps 3 through 6.

After the child restraint is removed and the seat belt is allowed to wind back into the retractor, the automatic locking mode (child restraint mode) is canceled; the seat belt only locks during a sudden stop or impact.

Rear facing



WARNING

- ***The three-point belt on your vehicle is equipped with a locking mode retractor which must be used when installing a child restraint.***

SEATS, RESTRAINTS AND SUPPLEMENTAL AIR BAG SYSTEMS

- **Failure to do so will result in the child restraint not being properly secured. It could tip over or otherwise be unsecured and cause injury to the child in a sudden stop or collision.**

When you install a child restraint in a rear outboard seat, follow these steps:

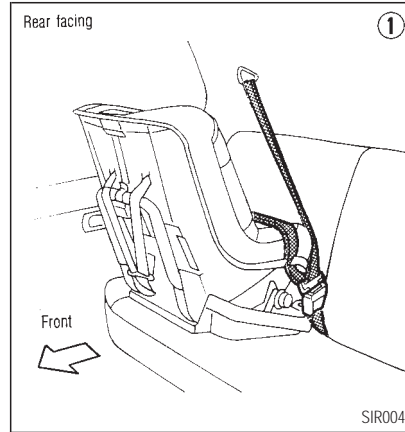

1. Position the child restraint on the seat. The direction of the child restraint depends on the type of the child restraint and the size of the child. Always follow the restraint manufacturer's instructions.

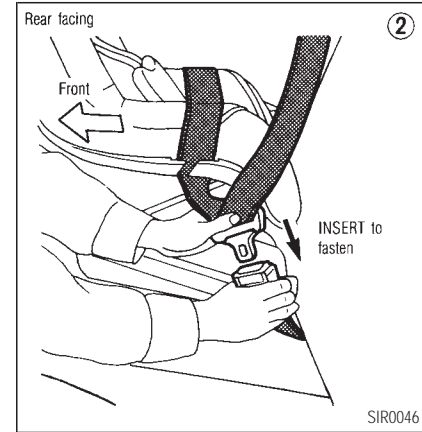

2. Route the seat belt tongue through the child restraint and insert it into the buckle until you hear and feel the latch engage. Be sure to follow the child restraint manufacturer's instructions for belt routing.

SEATS, RESTRAINTS AND SUPPLEMENTAL AIR BAG SYSTEMS

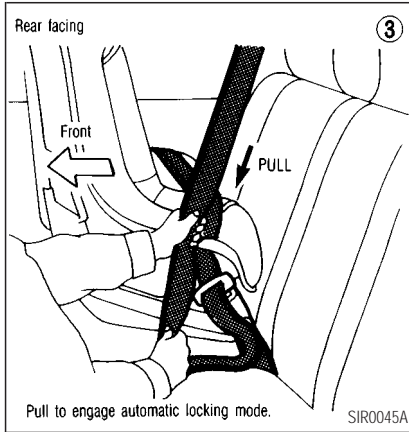

3. Pull on the shoulder belt until all of the belt is fully extended. At this time, the belt retractor is in the automatic locking mode (child restraint mode). It reverts back to emergency locking mode when the belt is fully retracted.

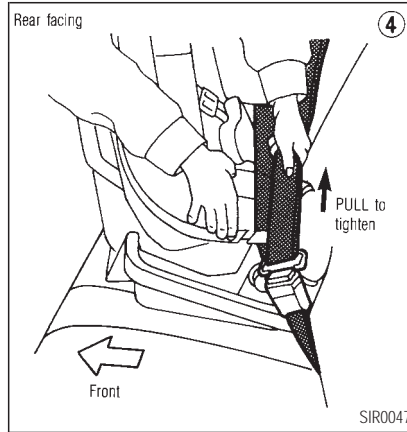

4. Allow the belt to retract. Pull up on the belt to remove any slack in the belt.

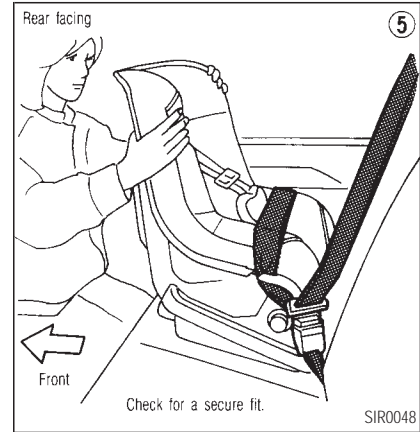

5. Before placing the child in the child restraint, use force to tilt the child restraint from side to side, and tug it forward to make sure that it is securely held in place.
6. Check that the retractor is in the automatic locking mode by trying to pull more belt out of the retractor. If you cannot pull any

SEATS, RESTRAINTS AND SUPPLEMENTAL AIR BAG SYSTEMS

more belt webbing out of the retractor, the belt is in the automatic locking mode.

7. Check to make sure the child restraint is properly secured prior to each use. If the belt is not locked, repeat steps 3 through 6.

After the child restraint is removed and the seat belt is allowed to wind back into the retractor, the automatic locking mode (child restraint mode) is canceled; the seat belt only locks during a sudden stop or impact.

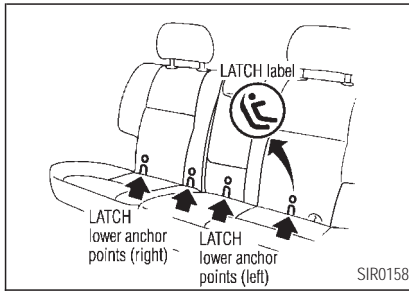

LATCH (LOWER ANCHORS AND TETHER FOR CHILDREN) SYSTEM

WARNING

- **Attach LATCH system compatible child restraints only at the locations shown. If a child restraint is not secured properly, your child could be seriously injured or killed in an accident.**
- **Do not secure a child restraint in the center rear seating position using the child restraint lower anchors. The child restraint will not be secured properly.**
- **The LATCH system anchors are designed to withstand only those loads imposed by correctly fitted**

child restraints. Under no circumstance are they to be used for adult seat belts or harnesses.

Some child restraints include two rigid or webbing-mounted attachments that can be connected to two anchors located at certain seating positions in your vehicle. This system is known as the LATCH (Lower Anchors and Tether for Children) system. This system may also be referred to as the ISOFIX or ISOFIX compatible system. With this system, you do not have to use a vehicle seat belt to secure the child restraint. Your vehicle is equipped with special anchor points that are used with LATCH system compatible child restraints. Check your child restraint for a label stating that it is compatible with the LATCH system. This information may also be in the child restraint owner's manual. If you have such a child restraint, refer to the illustration for the seating positions equipped with LATCH sys-

SEATS, RESTRAINTS AND SUPPLEMENTAL AIR BAG SYSTEMS

tem anchors which can be used to secure the child restraint.

The LATCH system anchors are located at the rear of the seat cushion near the seatback. A label is attached to the seatback to help you locate the LATCH system anchors.

Some child restraints may also require the use of a top tether strap. See “Top tether strap child restraint” later in this section for installation instructions.

When installing a child restraint, carefully read and follow the instructions in this manual and those supplied with the child restraint.

When you install a LATCH system compatible child restraint to the lower anchor attachments, follow these steps.



WARNING

Inspect the lower anchors by insert-

ing your fingers into the lower anchor area and feeling to make sure there are no obstructions over the LATCH system anchors, such as seat belt webbing or seat cushion material. The child restraint will not be secured properly if the LATCH system anchors are obstructed.

1. To install the LATCH system compatible child restraint, adjust the height of the child restraint LATCH system anchor attachments to the anchor points on the seat.
2. Insert the anchor attachments into the anchor points. If the child restraint is equipped with a top tether, see “Top tether strap child restraint” later in this section for installation instructions.
3. After attaching the child restraint and before placing the child in it, use force to

tilt the child restraint from side to side and tug it forward to make sure that the child restraint is securely held in place.

4. Check to make sure that the child restraint is properly secured prior to each use.

TOP TETHER STRAP CHILD RESTRAINT

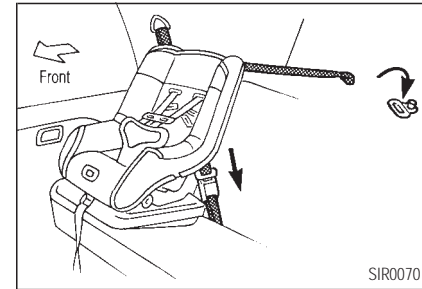

SEATS, RESTRAINTS AND SUPPLEMENTAL AIR BAG SYSTEMS

WARNING

- *The child restraint anchor points are designed to withstand only those loads imposed by correctly fitted child restraints. Under no circumstances are they to be used for adult seat belts or harnesses.*
- *The top tether strap may be damaged by contact with the tonneau cover or items in the cargo area. Remove the tonneau cover from the vehicle or secure it and any cargo. Your child could be seriously injured or killed in a collision if the top tether strap is damaged.*

If your child restraint has a top tether strap, it must be secured to the provided anchor point.

Secure the child restraint with the center lap belt or the lap portion of an outboard three-point belt and latch the top strap hook onto the anchor bracket.

Secure the top strap to the anchor bracket which provides the straightest installation of the top strap. Tighten the strap according to the manufacturer's instructions to remove any slack.

Anchor point locations

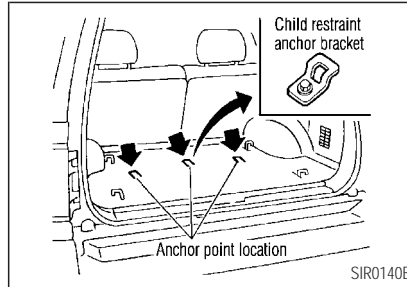

WARNING

The anchor bolt should be installed at all times to prevent the possibility of exhaust fumes entering the passenger compartment through the holes. See "Precautions when starting and driving" in the "5. Starting and driving" section for exhaust gas.

Anchor points are located under the carpet of the rear luggage area floor.

When installing a top strap child restraint on the rear seat for the first time, consult your INFINITI retailer for details.

SEATS, RESTRAINTS AND SUPPLEMENTAL AIR BAG SYSTEMS

INSTALLATION ON FRONT PASSENGER SEAT

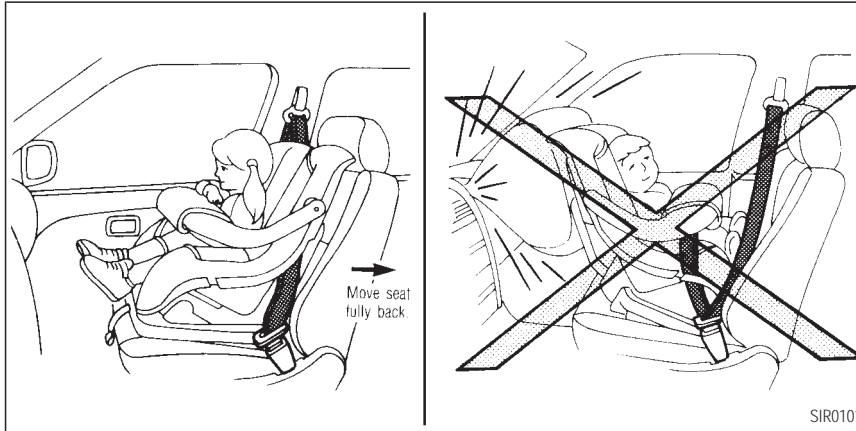

WARNING

- Never install a rear facing child

restraint in the front passenger seat. Supplemental front air bags inflate with great force. A rear

facing child restraint could be struck by the front air bag in a crash and could seriously injure or kill your child.

- INFINITI recommends that child restraints be installed in the rear seat. However, if you must install a front facing child restraint in the front passenger seat, move the passenger seat to the rear-most position.
- A child restraint with a top tether strap should not be used in the front passenger seat.
- The three-point belt in your vehicle is equipped with a locking mode retractor which must be used when installing a child restraint.

SEATS, RESTRAINTS AND SUPPLEMENTAL AIR BAG SYSTEMS

- Failure to use the retractor's locking mode may result in the child restraint not being properly secured. The child restraint could tip over or otherwise be unsecured and cause injury to the child in a sudden stop or collision.

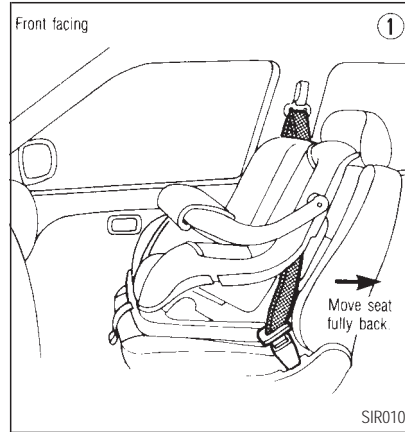

Front facing

If you must install a child restraint in the front seat, follow these steps:

1. Position the child restraint on the front passenger seat. **It should be placed in a front facing direction only.** Move the seat to the rear most position. Always follow

the child restraint manufacturer's instructions. **Child restraints for infants must be used in the rear facing direction and therefore must not be used in the front seat.**

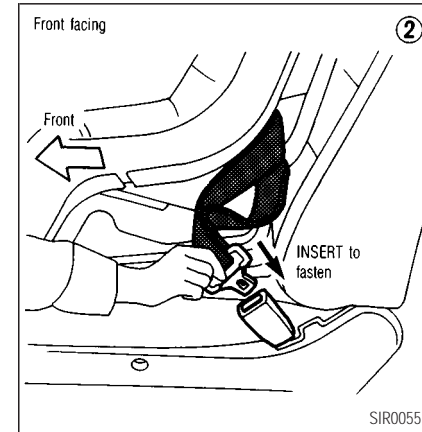

2. Route the seat belt tongue through the child restraint and insert it into the buckle

SEATS, RESTRAINTS AND SUPPLEMENTAL AIR BAG SYSTEMS

until you hear and feel the latch engage. Be sure to follow the child restraint manufacturer's instructions for belt routing.

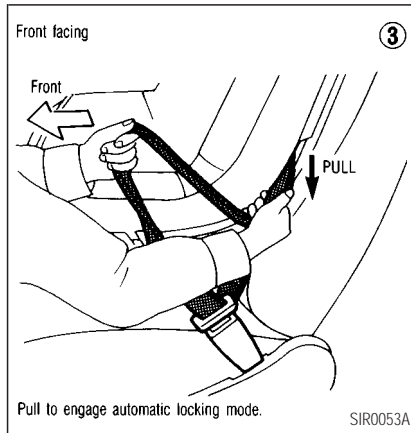

3. Pull on the shoulder belt until all of the belt is fully extended. At this time, the belt retractor is in the automatic locking mode (child restraint mode). It reverts back to

emergency locking mode when the belt is fully retracted.

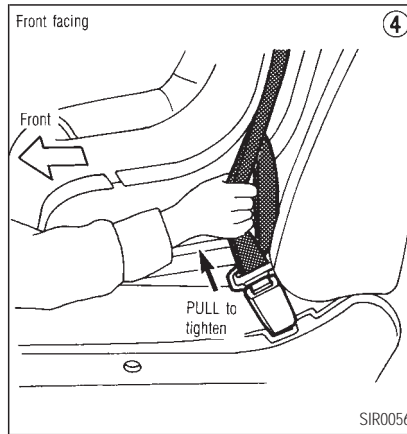

4. Allow the belt to retract. Pull up on the belt to remove any slack in the belt.



5. Before placing the child in the child restraint, use force to tilt the child restraint from side to side, and tug it forward to make sure that it is securely held in place.
6. Check that the retractor is in the automatic locking mode by trying to pull more belt out of the retractor. If you cannot pull any

SEATS, RESTRAINTS AND SUPPLEMENTAL AIR BAG SYSTEMS

more belt webbing out of the retractor, the belt is in the automatic locking mode.

7. Check to make sure that the child restraint is properly secured prior to each use. If the lap belt is not locked, repeat steps 3 through 6.

After the child restraint is removed and the seat belt is allowed to wind back into the retractor, the automatic locking mode (child restraint mode) is canceled; the seat belt only locks during a sudden stop or impact.

2 INSTRUMENTS AND CONTROLS

Instrument panel	2-2	Windshield wiper and washer switch.....	2-21
Meters and gauges	2-3	Rear window wiper and washer switch	2-21
Speedometer and odometer	2-4	Glass hatch and outside mirror defogger	
Tachometer.....	2-4	switch	2-22
Engine coolant temperature gauge	2-5	Headlight and turn signal switch.....	2-23
Fuel gauge.....	2-5	Xenon headlights.....	2-23
Compass and outside temperature		Headlight switch.....	2-24
display	2-6	Turn signal switch.....	2-27
Outside temperature display.....	2-6	Front fog light switch	2-27
Compass display.....	2-7	Hazard warning flasher switch	2-28
Warning/indicator lights and audible		Horn.....	2-28
reminders.....	2-10	Heated seats (if so equipped)	2-29
Checking bulbs.....	2-10	Clock.....	2-30
Warning lights.....	2-10	Adjusting the time.....	2-30
Indicator lights	2-15	Power outlet	2-30
Audible reminders	2-17	Cigarette lighter and ashtray.....	2-31
Security systems	2-18	Storage	2-32
Vehicle security system	2-18	Tray.....	2-32
Infiniti Vehicle Immobilizer System	2-19	Coin box (if so equipped)	2-32

Sunglasses holder	2-32	Personal light.....	2-46
Cup holders	2-33	Vanity mirror lights.....	2-47
Glove box	2-34	HomeLink® Universal Transceiver	2-47
Console box.....	2-34	Programming HomeLink®	2-48
Luggage storage.....	2-35	Programming HomeLink® for Canadian	
Luggage hooks.....	2-36	Customers	2-50
Cargo net.....	2-38	Operating the HomeLink® Universal	
Tonneau cover.....	2-38	Transceiver	2-50
Luggage rack (if so equipped)	2-40	Programming trouble-diagnosis.....	2-50
Windows	2-40	Clearing the programmed	
Power windows.....	2-41	information.....	2-50
Sunroof (if so equipped)	2-42	Reprogramming a single HomeLink®	
Electric sunroof	2-42	button	2-51
Interior lights (if so equipped)	2-45	If your vehicle is stolen.....	2-51

INSTRUMENTS AND CONTROLS

INSTRUMENT PANEL

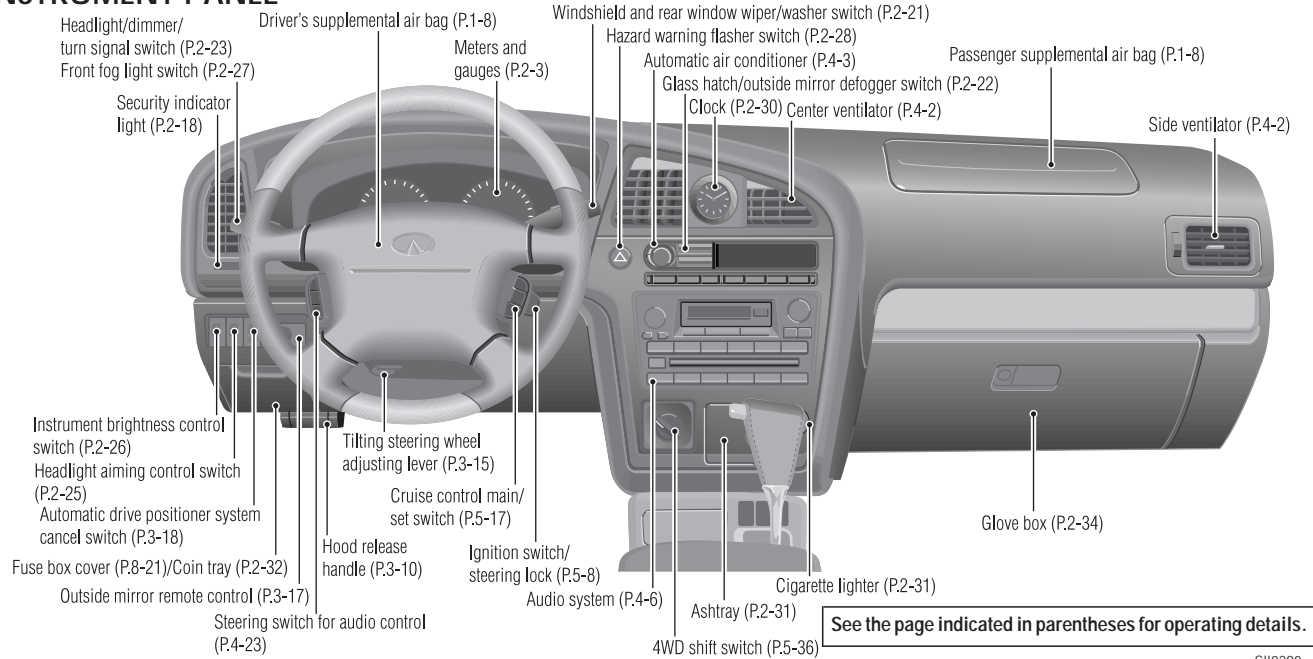

INSTRUMENTS AND CONTROLS

METERS AND GAUGES

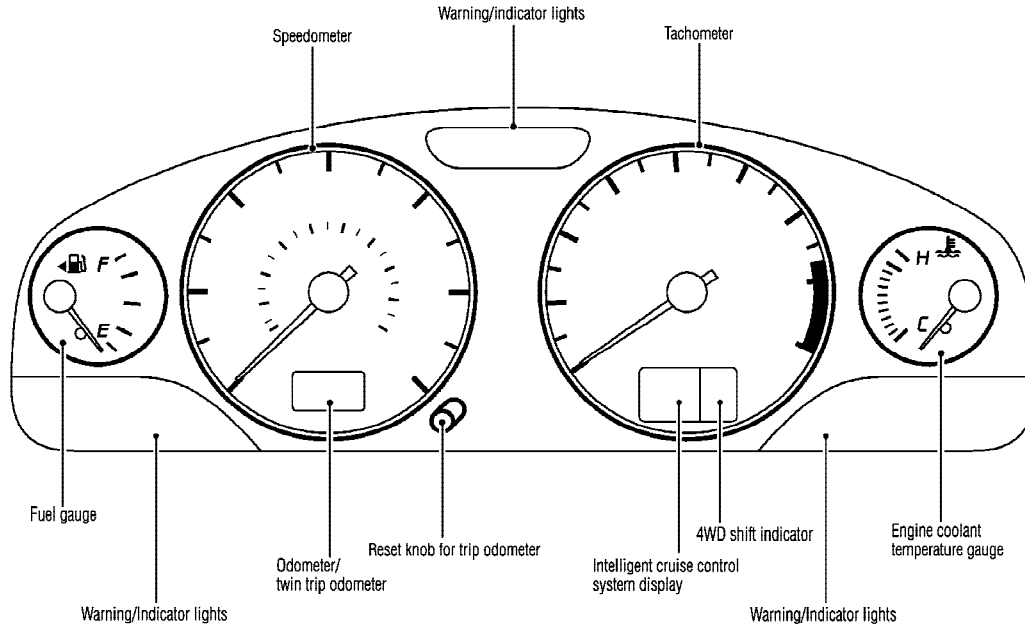

SII0401

INSTRUMENTS AND CONTROLS

SPEEDOMETER AND ODOMETER

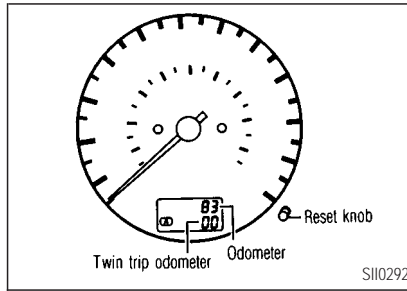

Speedometer

The speedometer indicates vehicle speed.

Odometer/twin trip odometer

The odometer/twin trip odometer are displayed when the ignition key is in the ON position.

The odometer records the total distance the vehicle has been driven.

The twin trip odometer records the distance of individual trips.

Changing the display :

Pushing the reset knob changes the display as follows:

TRIP A → TRIP B → TRIP A

Resetting the trip odometer :

Pushing the reset knob for more than 1 second resets the trip odometer to zero.

TACHOMETER

The tachometer indicates engine speed in revolutions per minute (r/min).

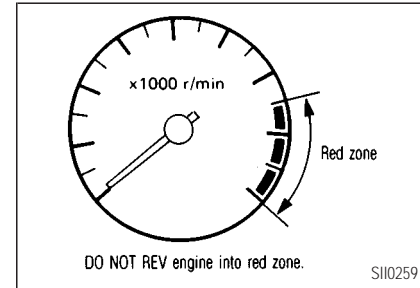

CAUTION

When engine speed approaches the red zone, shift to a higher gear. Operating the engine in the red zone may cause serious engine damage.

INSTRUMENTS AND CONTROLS

ENGINE COOLANT TEMPERATURE GAUGE

The gauge indicates engine coolant temperature.

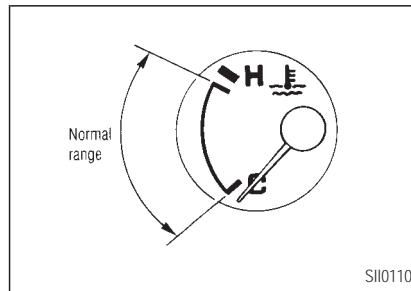

Engine coolant temperature will vary with the outside air temperature and driving conditions.

CAUTION

If the gauge indicates engine coolant temperature over the normal range, stop the vehicle as soon as safely possible. If the engine is overheated, continued operation of the vehicle may seriously damage the engine. See "If your vehicle overheats" in the "6. In case of emergency" section for immediate action required.

FUEL GAUGE

The gauge indicates the approximate fuel level in the tank.

The gauge may move slightly during braking, turning, acceleration, or going up or down hill.

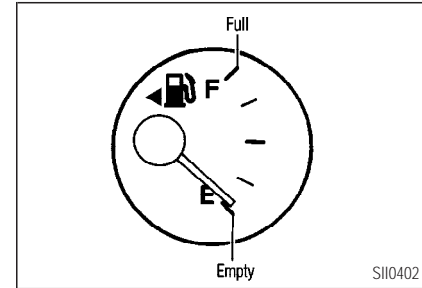

The gauge needle is designed to move to the E (Empty) position when the ignition key is turned to the OFF position.

Refill the fuel tank before the gauge registers Empty.

The low fuel warning light comes on when the fuel tank is getting low. Refuel as soon as it is convenient, preferably before the gauge reaches E. There will be a small reserve of fuel in the tank when the fuel gauge needle reaches E.

INSTRUMENTS AND CONTROLS

The  indicates that the fuel filler lid is located on the driver's side of the vehicle.

CAUTION

- *If the vehicle runs out of fuel, the malfunction indicator lamp (MIL) may come on. Refuel as soon as possible. After a few driving trips, the lamp should turn off. If the lamp remains on after a few driving trips, have the vehicle inspected by an authorized INFINITI retailer.*
- *For additional information, see "Malfunction indicator lamp (MIL)" later in this section.*

COMPASS AND OUTSIDE TEMPERATURE DISPLAY

This unit is a display unit with the following functions:

- Function to measure terrestrial magnetism and indicate heading direction of vehicle
- Function to indicate outside air temperature
- Function to indicate caution for frozen road surfaces

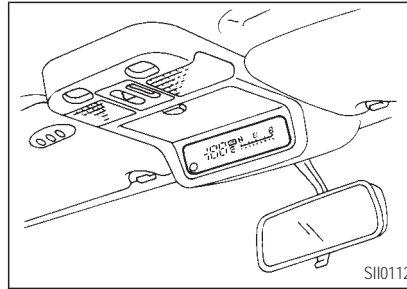

OUTSIDE TEMPERATURE DISPLAY

Push the switch when the ignition key is in the ACC or ON position. The outside temperature will be displayed in °F.

- Push the switch to change from °F to °C.
- If the outside temperature drops below the freezing point, the display indicates ICE.

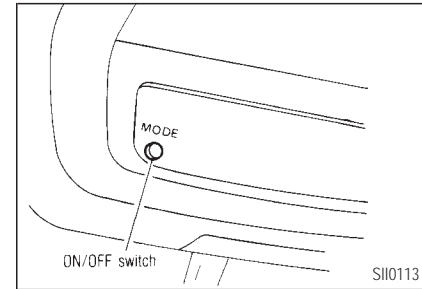

- When the outside temperature is between 130°F (55°C) and 158°F

INSTRUMENTS AND CONTROLS

(70°C), the display shows 130°F (55°C).

- When the outside temperature is lower than -20°F (-30°C) or higher than 158°F (70°C), the display shows only . . . though it is operating. This is not a malfunction.
- The outside temperature sensor is located in front of the radiator. The sensor may be affected by road or engine heat, wind direction and other driving conditions. The display may differ from the actual outside temperature or the temperature displayed on various signs or billboards.



CAUTION

Use the ICE indication for reference only. Confirm the traffic information

and road conditions to drive safely.

COMPASS DISPLAY

Push the switch when the ignition key is in the ACC or ON position. The direction will be displayed.

Zone variation change procedure

The difference between magnetic north and geographical north is known as variance. In some areas, this difference can sometimes be great enough to cause false compass readings. Follow these instructions to set the variance for your particular location if this happens:

1. Establish your location on the zone map. Record your zone number.
2. Push the ON/OFF switch in for five seconds until the current zone entry number is displayed.

3. Press the ON/OFF switch repeatedly until the new zone entry number is displayed.

Once the desired zone number is displayed, stop pressing the ON/OFF switch and the display will show compass direction within a few seconds.

INSTRUMENTS AND CONTROLS

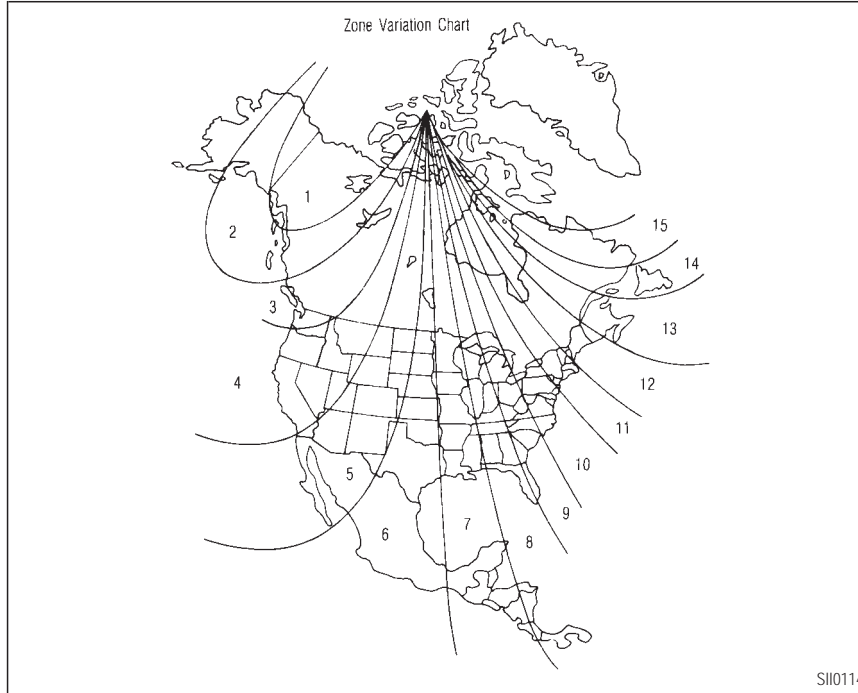

- If a magnet is located near the compass or the vehicle is driven where the terrestrial magnetism is disturbed, the compass display may not indicate the correct direction.
- In places where the terrestrial magnetism is disturbed, the correction of the direction starts automatically, extinguishing the direction bar. If turn is made one or two times, the correction is complete and the direction bar comes back on.

Correction functions of the compass display

The compass display is equipped with automatic correction function. If the direction is not shown correctly, carry out the manual correction procedure set out below.

Manual correction procedure

1. Push the switch for about 10 seconds. The direction bar starts blinking.

INSTRUMENTS AND CONTROLS

2. Drive the vehicle slowly in an open and safe area. The initial correction is completed while turning in one or two turns.



























CAUTION

In places where the earth's magnetism is disturbed, the initial correction procedure may start automatically.





INSTRUMENTS AND CONTROLS

WARNING/INDICATOR LIGHTS AND AUDIBLE REMINDERS

 ABS	or		Anti-lock brake warning light		Low fuel warning light		4WD shift indicator light
			Automatic transmission oil temperature warning light		Low washer fluid warning light		High beam indicator light (Blue)
			Automatic transmission park warning light		Seat belt warning light		Malfunction indicator lamp (MIL)
	or		Brake warning light		Supplemental air bag warning light		Overdrive off indicator light
			Charge warning light		Cruise main switch indicator light (Green)		Transfer 4LO position indicator light
			Door open warning light		Intelligent cruise control system ON/OFF switch indicator light (Green; if so equipped)		Turn signal/hazard indicator lights
			Engine oil pressure warning light		Intelligent cruise control system warning light (Orange; if so equipped)		
			4WD warning light		Cruise set switch indicator light		

CHECKING BULBS

Turn the ignition key to ON without starting the engine. The following lights will come on:

 ,  ,  or **BRAKE** ,  , **4WD** , 

The following lights come on briefly and then

go off:

 , **4LO** , **ABS** or  ,  , 

If any light fails to come on, it may indicate a burned-out bulb or an open circuit in the electrical system. Have the system repaired promptly.

WARNING LIGHTS

 or  **Anti-lock brake warning light**

The light should turn off within 1 second after turning the ignition switch to ON. If not, the system is malfunctioning.

INSTRUMENTS AND CONTROLS

If the light comes on while the engine is running, it may indicate the anti-lock brake system is not functioning properly. In either case, have the system checked by your INFINITI dealer.

If an abnormality occurs in the system, the anti-lock function will cease but the ordinary brakes will continue to operate normally.

If the light comes on while you are driving, contact your INFINITI retailer for repair.



Automatic transmission oil temperature warning light (if so equipped)

This light comes on when the automatic transmission oil temperature is too high. If the light comes on while driving, reduce the vehicle speed as soon as safely possible until the light turns off.



CAUTION

Continued vehicle operation when the A/T oil temperature warning light is on may damage the automatic transmission.



Automatic transmission park warning light (if so equipped)

This light indicates that the automatic transmission parking function is not engaged. If the transfer control is not secured in any drive position while the automatic transmission selector lever is in the P position, the transmission will disengage and the wheel will not lock.

The warning light may come on when the ignition switch is ON and the automatic

transmission lever is shifted to the P position while shifting the 4WD shift switch between 4H and 4L.

Shift the 4WD shift switch to the 2H, AUTO, 4H or 4LO position again when the warning light comes on, and make sure the 4WD shift indicator light is ON.

See "Parking" in the "5. Starting and driving" section.



WARNING

- ***If the ATP light is ON, this indicates that the automatic transmission P (Park) position will not function and the transfer case is in neutral.***
- ***When parking, always make sure that the 4WD shift indicator light is on and the parking brake is***

INSTRUMENTS AND CONTROLS

set before you stop the engine. Failure to engage the transfer case in 2H, AUTO, 4H or 4LO could result in the vehicle moving unexpectedly, resulting in serious personal injury or property damage.



or



Brake warning light

This light functions for both the parking brake and the foot brake systems.

Parking brake indicator :

The light comes on when the parking brake is applied.

Low brake fluid warning light :

When the ignition key is in the ON position the light warns of a low brake fluid level. If the light comes on while the engine is running

with the parking brake not applied, stop the vehicle and perform the following:

1. Check the brake fluid level. Add brake fluid as necessary. See "Brake fluid" in the "8. Do-it-yourself" section.
2. If the brake fluid level is correct, have the warning system checked by your INFINITI retailer.



WARNING

- ***Your brake system may not be working properly if the warning light is on. Driving could be dangerous. If you judge it to be safe, drive carefully to the nearest service station for repairs. Otherwise, have your vehicle towed.***
- ***Pressing the brake pedal with the engine stopped and/or low brake***

fluid level may increase your stopping distance and braking will require greater pedal effort as well as greater pedal travel.

- ***If the brake fluid level is below the MIN mark on the brake fluid reservoir, do not drive until the brake system has been checked at an INFINITI retailer.***



Charge warning light

If the light comes on while the engine is running, it may indicate the charging system is not functioning properly. Turn the engine off and check the alternator belt. If the belt is loose, broken, missing or if the light remains on, see your INFINITI retailer immediately.

INSTRUMENTS AND CONTROLS

CAUTION

Do not continue driving if the belt is loose, broken or missing.

Door open warning light

This light comes on when any of the doors or rear window are not closed securely while the ignition key is ON.

Engine oil pressure warning light

This light warns of low engine oil pressure. If the light flickers or comes on during normal driving, pull off the road in a safe area, stop the engine **immediately** and call an INFINITI retailer or other authorized repair shop.

The oil pressure warning light is not designed to indicate a low oil level. Use the dipstick to check the oil level. See

“Engine oil” in the “8. Do-it-yourself” section.

CAUTION

Running the engine with the oil pressure warning light on could cause serious damage to the engine almost immediately. Turn off the engine as soon as it is safe to do so.

4WD warning light (if so equipped)

The four wheel drive warning light comes on when the key switch is turned to ON. It turns off soon after the engine is started.

If the engine or vehicle is not functioning properly, the warning light will either remain illuminated or blink. See “4WD warning light” in the “5. Starting and driving” section.

CAUTION

- *If the warning light comes on or blinks during operation, have your vehicle checked by an authorized INFINITI retailer as soon as possible.*
- *Do not drive on dry hard surface roads in the 4H or 4LO position. If the 4WD warning light turns on when you are driving on dry hard surface roads*
 - *in the AUTO or 4H position, shift the 4WD shift switch to 2WD.*
 - *in the 4LO position, stop the vehicle, move the automatic transmission lever to the N position, and shift the 4WD*

INSTRUMENTS AND CONTROLS

shift switch to 2WD and the automatic transmission lever to the D position.

If the warning light is still on after the above operation, have your vehicle checked by an authorized INFINITI retailer as soon as possible.



Low fuel warning light

This light comes on when the fuel in the tank is getting low. Refuel as soon as it is convenient, preferably before the fuel gauge reaches E.

There will be a small reserve of fuel remaining in the tank when the fuel gauge needle reaches E.



Low washer fluid warning light

This light comes on when the washer tank fluid is at a low level. Add washer fluid as necessary. See “Window washer fluid” in the “8. Do-it-yourself” section.



Seat belt warning light and chime

The light and chime remind you to fasten seat belts. The light illuminates whenever the ignition key is turned to ON, and will remain illuminated until the driver's seat belt is fastened. At the same time, the chime will sound for about six seconds unless the driver's seat belt is securely fastened.

Refer to “Seat belts” in the “1. Seats, restraints and supplemental air bag systems” section for precautions on seat belt usage.



Supplemental air bag warning light

After turning the ignition key to the ON position, the supplemental air bag light will illuminate. The supplemental air bag warning light will turn off after about 7 seconds if the supplemental front air bag and supplemental side air bag systems and pre-tensioner seat belt are operational.

If any of the following conditions occur, the supplemental air bag and pre-tensioner seat belt needs servicing and your INFINITI must be taken to your nearest authorized INFINITI retailer.

- The supplemental air bag warning light remains on after approximately 7 seconds.
- The supplemental air bag warning light flashes intermittently.
- The supplemental air bag warning light does not come on at all.

INSTRUMENTS AND CONTROLS

Unless checked and repaired, the supplemental restraint system and/or the pre-tensioner seat belt may not function properly.

For additional information, see “Supplemental restraint system” in the “1. Seats, restraints and supplemental air bag” section.



WARNING

If the supplemental air bag warning light is on, it could mean that the supplemental front air bag system, supplemental side air bag system and/or the pre-tensioner seat belt will not operate in an accident.

INDICATOR LIGHTS



Cruise main switch indicator light (Green)

The light comes on when the main switch is turned ON.



Intelligent cruise control system ON/OFF switch indicator light (Green; if so equipped)

The light comes on when the ICC system ON/OFF switch is pushed. The light goes out when the ON/OFF switch is pushed again. While the ON/OFF switch indicator light comes on, the ICC system is operational.



Intelligent cruise control system warning light (Orange)

The light comes on if there is a malfunction in the intelligent cruise control system.



Cruise set switch indicator light

The light comes on while the vehicle speed is controlled by the cruise control system. If the light flickers while the engine is running, it may indicate the cruise control system is not functioning properly. Have the system

checked by your INFINITI retailer.



4WD shift indicator light (if so equipped)

The light should turn off within 1 second after turning the ignition switch to ON.

While the engine is running, the 4WD shift indicator light will illuminate the position selected by the 4WD shift switch.

The 4WD shift indicator light may blink while shifting from one drive mode to the other.



High beam indicator light (Blue)

This light comes on when the headlight high beam is on and goes out when the low beam is selected.



Malfunction indicator lamp (MIL)

If the Malfunction indicator lamp comes on

INSTRUMENTS AND CONTROLS

steady or blinks while the engine is running, it may indicate a potential emission control malfunction.



The Malfunction indicator lamp may also come on steady if the fuel filler cap is loose or missing, or if the vehicle runs out of fuel. Check to make sure the fuel filler cap is installed and closed tightly, and that the vehicle has at least 3 US gallons (14 liters) of fuel in the fuel tank.

After a few driving trips, the  lamp should turn off if no other potential emission control system malfunction exists.

Operation

The Malfunction indicator lamp will come on in one of two ways:

- Malfunction indicator lamp on steady — An emission control system malfunction has been detected. Check the fuel filler cap. If the fuel filler cap is loose or missing, tighten or install the cap and

continue to drive the vehicle. The  lamp should turn off after a few driving trips. If the  lamp does not turn off after a few driving trips, have the vehicle inspected by an authorized INFINITI retailer. You do not need to have your vehicle towed to the dealer.

- Malfunction indicator lamp blinking — An engine misfire has been detected which may damage the emission control system. To reduce or avoid emission control system damage:

- * do not drive at speeds above 45 MPH (72 km/h).
- * avoid hard acceleration or deceleration.
- * avoid steep uphill grades.
- * if possible, reduce the amount of cargo being hauled or towed.

The malfunction indicator light may stop blinking and come on steady.

Have the vehicle inspected by an autho-

rized INFINITI retailer. You do not need to have your vehicle towed to the dealer.



CAUTION

Continued vehicle operation without having the emission control system checked and repaired as necessary could lead to poor driveability, reduced fuel economy, and possible damage to the emission control system.



Overdrive off indicator light

This light comes on during driving when the overdrive switch is pressed to prevent overdrive operation.

The O/D OFF indicator light comes on for two seconds each time the ignition key is turned

INSTRUMENTS AND CONTROLS

ON. This shows the light is functioning properly.

If the O/D OFF indicator light blinks for approximately 8 seconds after coming on for 2 seconds, have your INFINITI retailer check the transmission and repair it if necessary.

The automatic transmission is equipped with an electronic Fail-Safe mode. This system allows the vehicle to be driven even in the event of damage to the electrical circuits. If this occurs, the gears automatically engage and lock into 3rd gear.

See the “Driving the vehicle” in the “5. Starting and driving” section for fail-safe before visiting your INFINITI retailer.

4LO *Transfer 4LO position indicator light (if so equipped)*

The light should turn off within 1 second after turning the ignition switch to ON.

This light comes on when the 4WD shift switch is set in the 4LO position with ignition key in the ON position.

If the 4WD shift switch is set in the 4LO position and the light blinks, stop the vehicle, drive slowly forward and the light will turn on.

When you shift between 4H and 4LO, stop the vehicle, move the automatic transmission selector lever to the N position, and push the 4WD shift switch and move it in 4LO or 4H.

The transfer case may be damaged if you shift the switch while driving.

You cannot move the transfer 4WD shift switch between 4H and 4LO unless you have first stopped the vehicle and moved the automatic transmission shift lever to neutral. Make sure the transfer 4LO position indicator light turns on when you shift the 4WD shift switch to 4LO.

The indicator light may blink while shifting from one drive mode to the other.

Turn signal/hazard indicator lights

The light flashes when the turn signal switch lever or hazard switch is turned on.

AUDIBLE REMINDERS

Brake pad wear warning

The disc brake pads have audible wear warnings. When a brake pad requires replacement, it will make a high pitched scraping sound when the vehicle is in motion whether or not the brake pedal is depressed. Have the brakes checked as soon as possible if the warning sound is heard when the vehicle is moving, whether or not the brake pedal is depressed.

Key reminder chime

The chime will sound if the driver side door is opened while the key is left in the ignition switch. Remove the key and take it with you when leaving the vehicle.

INSTRUMENTS AND CONTROLS

Light reminder chime

The chime will sound when the driver's side door is opened with the headlight switch on unless the ignition key is in the ON position.

Make sure to turn the light switch off when you leave the vehicle.

SECURITY SYSTEMS

Your vehicle has two types of security system, as follows:

- Vehicle security system
- Infiniti Vehicle Immobilizer System

The security condition will be shown by the security indicator light.

VEHICLE SECURITY SYSTEM

The vehicle security system provides visual and audio alarm signals if parts of the vehicle are disturbed.

Security indicator light

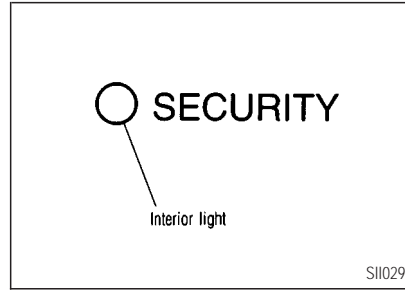

How to activate the vehicle security system

1. Close all windows.

The system can be activated even if the windows are open.

2. Remove the key from the ignition switch.

3. Close and lock all doors, hood, back door and back door glass hatch. All doors can be locked either with the multi-remote controller, a key, the door lock knob or the lock-unlock switch. See "Doors" in the "3. Pre-driving checks and adjustments" section for locking all doors simultaneously.
4. Confirm that the security indicator light comes on. The security light glows for about 30 seconds and then begins to flash. The system is now activated. If, during this 30 second time period, the door is unlocked by the key or keyfob, or the ignition key is turned to ACC or ON, the system will not activate.

INSTRUMENTS AND CONTROLS

- Even when the driver and/or passengers are in the vehicle, the system will activate with all doors, hood, back door and back door glass hatch locked and ignition key off. Turn the ignition key to ACC to turn the system off.

Vehicle security system operation

The vehicle security system will give the following alarm:

- The headlights blink and the horn sounds intermittently.
- The alarm automatically turns off after 1 minute; however, the alarm will reactivate if the vehicle is tampered with again.

The alarm is activated by:

- Unlocking the door or back door without using the key or keyfob. (Even if the door is opened by releasing the door inside lock knob, the alarm is activated.)
- Opening the hood. (Even if the hood is opened by the hood release handle, the alarm is activated.)
- Opening the back door glass hatch (Even if the back door glass hatch is opened by the opener switch, the alarm is activated.)
- Connecting the battery connector after it has been disconnected from the battery for more than 1 second.

How to stop alarm

The alarm will stop only by unlocking a door or back door with the key or keyfob. The alarm will not stop if the ignition switch is turned to ACC or ON.

If the system does not operate as described above, have it checked by your INFINITI retailer.

INFINITI VEHICLE IMMOBILIZER SYSTEM

The Infiniti Vehicle Immobilizer System will not allow the engine to start without the use of the registered Infiniti Vehicle Immobilizer System key.

If the engine fails to start using the registered Infiniti Vehicle Immobilizer System key (for example, when interference is caused by another Infiniti Vehicle Immobilizer System key, an automated toll road device or automated payment device on the key ring), restart the engine using the following procedures:

1. Leave the ignition switch in the ON position for approximately 5 seconds.
2. Turn the ignition switch to the OFF or LOCK position, and wait approximately 5 seconds.

INSTRUMENTS AND CONTROLS

3. Repeat step 1 and 2.
4. Restart the engine while holding the device (which may have caused the interference) separate from the registered Infiniti Vehicle Immobilizer System key.

If this procedure allows the engine to start, INFINITI recommends placing the registered Infiniti Vehicle Immobilizer System key on a separate key ring to avoid interference from other devices.

**Statement related to section 15 of FCC rules for Infiniti Vehicle Immobilizer System
(CONT ASSY - IMMOBILIZER, ANT ASSY - IMMOBILIZER)**

This device complies with part 15 of the FCC Rules and RSS-210 of Industry Canada. Operation is subject to the following two conditions;

- (1) This device may not cause harmful interference, and (2) this device must

accept any interference received, including interference that may cause undesired operation of the device.

CHANGES OR MODIFICATIONS NOT EXPRESSLY APPROVED BY THE MANUFACTURE FOR COMPLIANCE COULD VOID THE USER'S AUTHORITY TO OPERATE THE EQUIPMENT.

Security indicator light

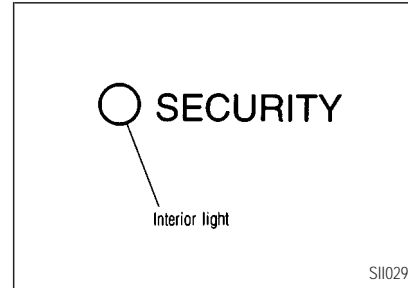

This light blinks whenever the ignition switch is in the LOCK, OFF or ACC position. This function indicates the security systems equipped on the vehicle are operational.

If the Infiniti Vehicle Immobilizer System is malfunctioning, this light will remain on while the ignition key is in the ON position.

If the light still remains on and/or the engine will not start, see your INFINITI retailer for Infiniti Vehicle Immobilizer System service as soon as possible. Please bring all Infiniti Vehicle Immobilizer System keys that you have when visiting your INFINITI retailer for service.

INSTRUMENTS AND CONTROLS

WINDSHIELD WIPER AND WASHER SWITCH

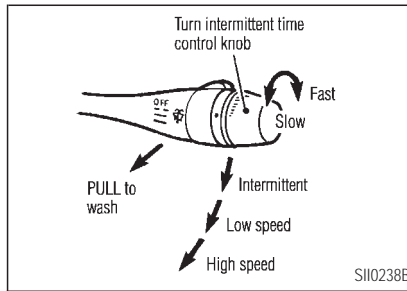

The windshield wiper and washer operates when the ignition key is in the ACC or ON position.

Push the lever down to operate the wiper.

Intermittent operation speed can be adjusted by turning the knob.

Pull the lever toward you to operate the washer. The wiper will also operate several times.

CAUTION

The following could damage the washer system:

- *Do not operate the washer continuously for more than 30 seconds.*
- *Do not operate the washer if the reservoir tank is empty.*

WARNING

In freezing temperatures the washer solution may freeze on the windshield and obscure your vision which may lead to an accident. Warm the windshield with the defroster before you wash the windshield.

REAR WINDOW WIPER AND WASHER SWITCH

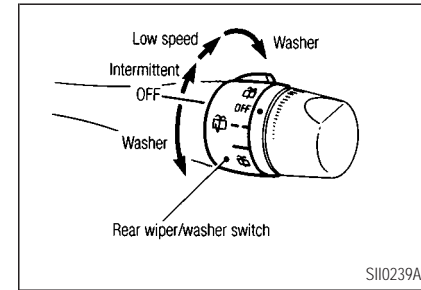

The rear window wiper and washer operates when the ignition switch is in the ACC or ON position.

Turn the switch clockwise to the intermittent, low speed,  position to operate the wiper or washer.

Turn the switch counterclockwise to the  position to operate the washer. Then the wiper will also operate several times.

INSTRUMENTS AND CONTROLS

CAUTION

- Do not operate the washer continuously for more than 30 seconds.
- Do not operate the washer if reservoir tank is empty.

- The rear window wiper will not operate when the glass hatch is open.

The rear window wiper will not operate if the glass hatch is closed with the wiper switch on. To operate the window wiper, turn the switch to off and then to on.

- The glass hatch will not open while the rear window wiper is operating.

WARNING

In freezing temperatures the washer solution may freeze on the glass hatch and obscure your vision which may lead to an accident. Warm the glass hatch with the defroster before you wash the glass hatch.

GLASS HATCH AND OUTSIDE MIRROR DEFOGGER SWITCH

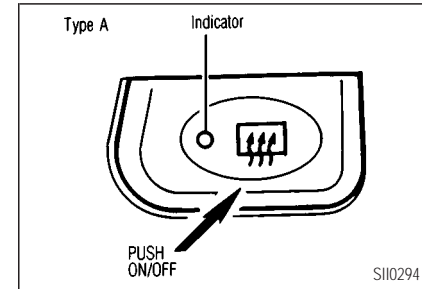

INSTRUMENTS AND CONTROLS

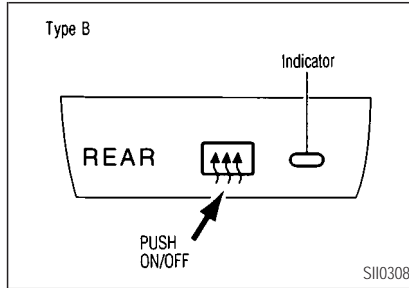

To defog the glass hatch and the outside door mirrors, start the engine and push the switch on. (The indicator light will come on.) Push the switch again to turn the defogger off.

It will automatically turn off in approximately 15 minutes. If the window clears before this time, push the switch off manually.



CAUTION

When cleaning the inner side of the window, be careful not to scratch or damage the glass hatch defogger.

HEADLIGHT AND TURN SIGNAL SWITCH

XENON HEADLIGHTS



WARNING



HIGH VOLTAGE

- *When xenon headlights are on, they produce a high voltage. To prevent an electric shock, never attempt to modify or disassemble. Always have your xenon head-*

lights replaced at an authorized INFINITI retailer.

- *Xenon headlights provide considerably more light than conventional headlights. If they are not correctly aimed, they might temporarily blind an oncoming driver or the driver ahead of you and cause a serious accident. If headlights are not aimed correctly, immediately take your vehicle to an authorized INFINITI retailer and have the headlights adjusted correctly.*

When the xenon headlight is initially turned on, its brightness or color varies slightly. However, the color and brightness will soon stabilize.

- *The life of xenon headlights will be shortened by frequent on-off opera-*

INSTRUMENTS AND CONTROLS

tion. It is generally desirable not to turn off the headlights for short intervals, (for example, when the vehicle stops at a traffic signal). Even when the daytime running lights are active (Canada only), the xenon headlights do not turn on. This way the life of the xenon headlights is not reduced.

- If the xenon headlight bulb is close to burning out, the brightness will drastically decrease, the light will start blinking, or the color of the light will become reddish. If one or more of the above signs appear, contact an INFINITI retailer.

HEADLIGHT SWITCH

Lighting

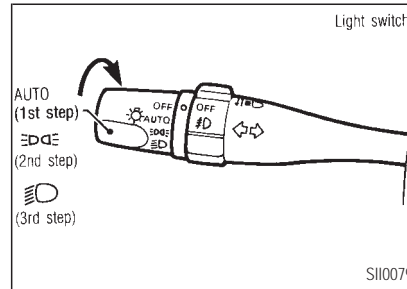

Turn the switch to the AUTO position:

When the ignition key is in the ON position, the tail light, headlight, instrument light and other lights turn on automatically, depending on the brightness of the surroundings. The headlight will automatically turn off 5 minutes after the ignition switch has been turned to the OFF position and the driver's or front passenger's door is opened.

The headlight will also automatically turn off 45 seconds after a front door is opened and closed.

When the light switch is turned to the OFF position, the headlight low or high beam will turn off.

Turn the switch to the OFF position:

The front parking, tail, license plate and instrument lights will come on.

Turn the switch to the PARKING LIGHTS position:

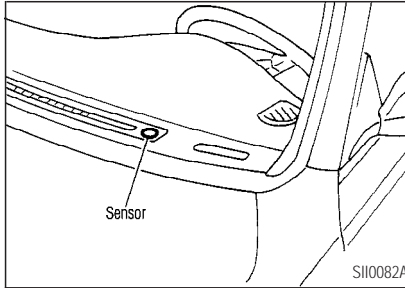

Headlights will come on and all the other lights remain on.

INSTRUMENTS AND CONTROLS







Be sure not to put anything on top of the photo sensor located on the top right-hand side of the instrument panel. The photo sensor controls the autolight; if it is covered, the photo sensor reacts as if it is dark and the headlights will illuminate.

Battery saver system

- When the headlight switch is in the  or  position while the ignition key is in the ON position, the lights including the front fog light will automati-

cally turn off 5 minutes after the ignition switch has been turned to the OFF position.

- When the headlight switch remains in the  or  position after the lights automatically turn off, the lights will turn on when the headlight switch is turned to the OFF position and turn to the  or  position.



CAUTION

- *When you turn on the headlight switch again after the lights automatically turns off, the lights will not turn off automatically. Be sure to turn the light switch to the OFF position when you leave the vehicle for extended periods of time, otherwise the battery will go dead.*

- *Never leave the light switch on when the engine is not running for extended periods of time.*

Headlight aiming control

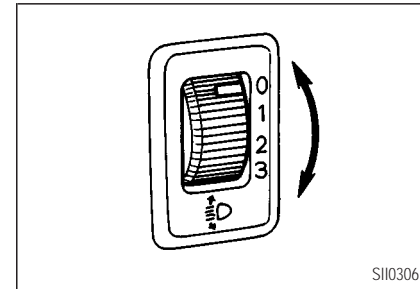

Depending on the number of occupants in the vehicle and the load it is carrying, the headlight axis may be higher than desired. If the vehicle is traveling on a hilly road, the headlights may directly hit the rearview mirror of the vehicle ahead or the windshield of the

INSTRUMENTS AND CONTROLS

oncoming vehicle. The light axis can be lowered with the operation of the switch.

The larger the number designated on the switch, the lower the axis.

When traveling with no heavy load or on a flat road, select position 0.

Xenon headlights are extremely bright compared to conventional headlights. If the xenon headlights hit the rearview mirror of the vehicle ahead or the windshield of the oncoming vehicle, the driver of these vehicles may have difficulty driving because of the brightness. Use the headlight aiming control switch to lower the light axis. See “Headlight and turn signal switch” earlier in this section for information on xenon headlights.

Instrument brightness control

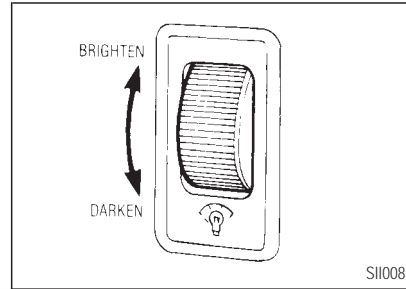

The instrument brightness control operates when the head light switch is in the ☰ or ☷ position.

Turn the control to adjust the brightness of the instrument panel lights.

When the control is turned upward until a click sound is heard, the light intensity will be at maximum. When the control is turned downward until a click sound is heard or felt, the light will be turned off.

Headlight beam select

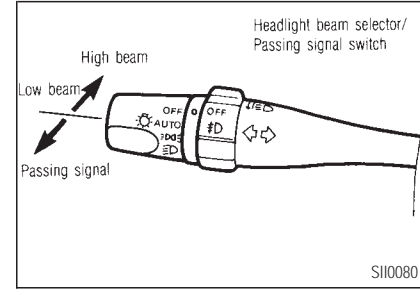

To select the high beam, push the lever forward. Pull it back to select the low beam.

Passing signal

Pulling the lever toward you will flash the headlight high beam.

INSTRUMENTS AND CONTROLS

Daytime running light system (Canada only)

The headlights automatically illuminate at a reduced intensity when the engine is started with the parking brake released. The daytime running lights operate with the headlight switch in the OFF position or in the D position. Turn the headlight switch to the D position for full illumination when driving at night.

If the parking brake is applied before the engine is started, the daytime running lights do not illuminate. The daytime running lights illuminate once the parking brake is released. The daytime running lights will remain on until the ignition switch is turned off.



WARNING

When the daytime running light sys-

tem is active, tail lights on your vehicle are not on. It is necessary at dusk to turn on your headlights. Failure to do so could cause an accident injuring yourself and others.

TURN SIGNAL SWITCH

Turn signal

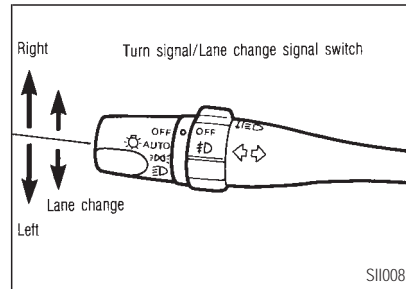

Move the lever up or down to signal the turning direction. When the turn is completed,

the turn signals cancel automatically.

Lane change signal

To indicate a lane change, move the lever up or down to the point where lights begin flashing.

FRONT FOG LIGHT SWITCH

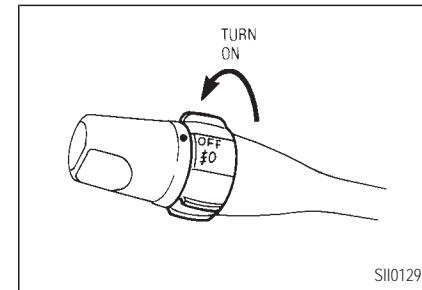

To turn the fog lights on, turn the headlight switch to the D position, then turn the switch to the D position. To turn them off, turn the switch to the OFF position.

INSTRUMENTS AND CONTROLS

The headlights must be on for the fog lights to operate.

HAZARD WARNING FLASHER SWITCH

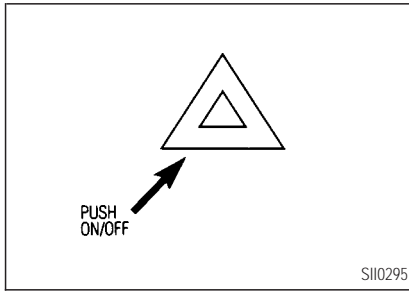

The switch is located on the instrument panel.

Push the switch on to warn other drivers when you must stop or park under emergency conditions. All turn signal lights will flash.

Some state laws may prohibit the use of the hazard warning flasher switch while driving.



WARNING

- *If stopping for an emergency, be sure to move the vehicle well off the road.*
- *Do not use the hazard warning flashers while moving on the highway unless unusual circumstances force you to drive so slowly that your vehicle might become a hazard to other traffic.*
- *Turn signals do not work when the hazard warning flasher lights are on.*

The flasher can be actuated with the ignition switch either off or on.

HORN

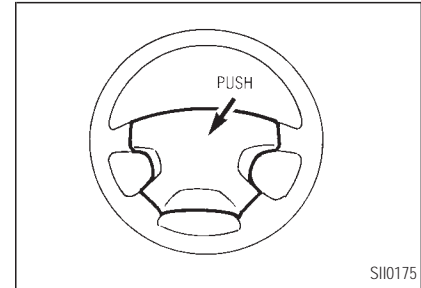

To sound the horn, push the center pad area of the steering wheel.



WARNING

Do not disassemble the horn. Doing so could affect proper operation of the supplemental front air bag system. Tampering with the supplemental front air bag system may result in



INSTRUMENTS AND CONTROLS

serious personal injury.

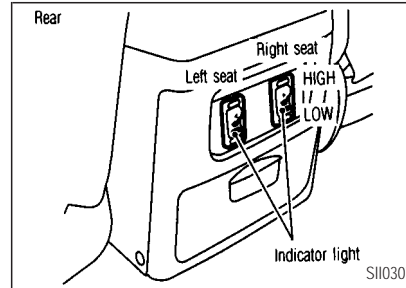
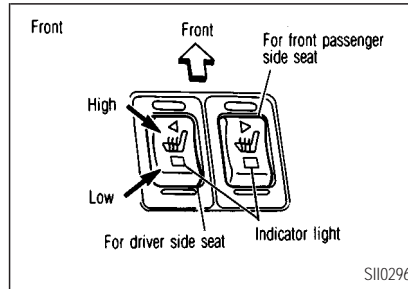
HEATED SEATS (if so equipped)



The seats are warmed by built-in heaters. The switches located on the center console and the rear side of the console box can be operated independently of each other.

1. Start the engine.
2. Push the  (Low) or  (High) position of the switch, as desired, depending on the temperature. The indicator light in the switch will illuminate.

The heater is controlled by a thermostat, automatically turning the heater on and off.

The indicator light will remain on as long as the switch is on.

3. When the vehicle's interior is warmed or before you leave the vehicle, be sure to turn the switch off.

For no heat, the switch has a center OFF position between low and high.



CAUTION

- *Do not use the seat heater for extended periods or when no one is using the seat.*
- *Do not put anything on the seat which insulates heat, such as a blanket, cushion, seat cover, etc. Otherwise, the seat may become overheated.*
- *Do not place anything hard or heavy on the seat or pierce it with*

INSTRUMENTS AND CONTROLS

a pin or similar object. This may result in damage to the heater.

- *Any liquid spilled on the heating seat should be removed immediately with a dry cloth.*
- *When cleaning the seat, never use gasoline, thinner, or any similar materials.*
- *If any abnormalities are found or the heating seat does not operate, turn the switch off and have the system checked by your INFINITI retailer.*
- *The battery could run down if the heater is operated while the engine is not running.*

CLOCK

If the power supply is disconnected, the clock will not indicate the correct time. Readjust the time.

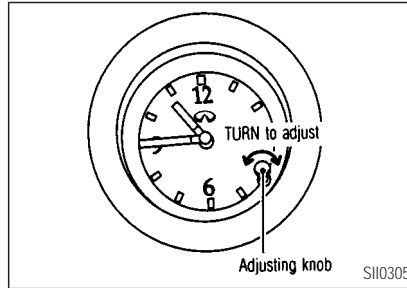

ADJUSTING THE TIME

To adjust the time, turn the adjusting knob.

POWER OUTLET

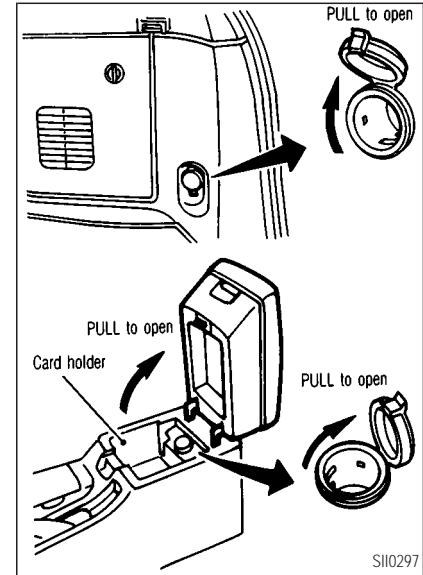

INSTRUMENTS AND CONTROLS

CAUTION

- Use caution as the socket and plug may be hot during or immediately after use.
- This power outlet is not designed for use with a cigarette lighter unit.
- Do not use with accessories that exceed a 12 volt, 120W (10A) power draw. Do not use double adapters or more than one electrical accessory.
- Use this power outlet with the engine running. (If the engine is stopped, this could result in a discharged battery.)
- Avoid using when the air conditioner, headlights or rear window

defogger is on.

- When not in use, be sure to close the cap. Do not allow water to contact the socket.
- Before inserting or disconnecting a plug, be sure to turn off the power switch of electrical accessory being used or the ACC power of the vehicle.
- Push the plug in as far as it will go. If good contact is not made, the plug may overheat or the internal temperature fuse may blow.

CIGARETTE LIGHTER AND ASHTRAY

The cigarette lighter operates when the ignition switch is in ACC or ON.

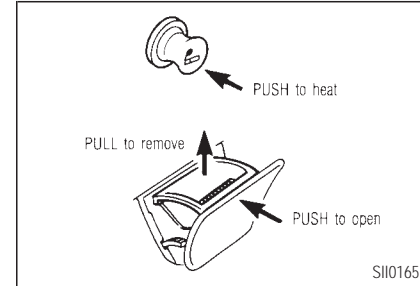

Push the lighter in all the way, then release it. When the lighter is heated, it will spring out. Return the lighter to its original position after use.

WARNING

The cigarette lighter should not be used while driving so full attention may be given to vehicle operation.

INSTRUMENTS AND CONTROLS

CAUTION

The cigarette lighter socket is a power source for the cigarette lighter element only. The use of the cigarette lighter socket as a power source for any other accessory is not recommended.

STORAGE TRAY

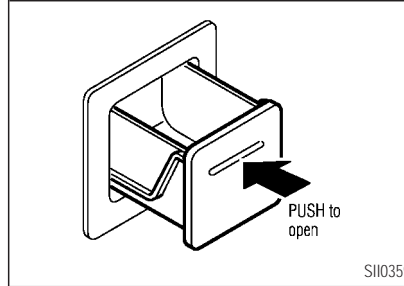
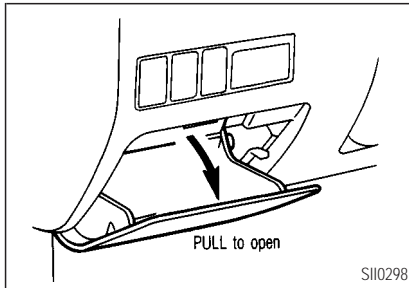

COIN BOX (if so equipped)

To open the box, lightly push it once and draw it out.

WARNING

The storage tray should not be used while driving so full attention may be given to vehicle operation.

Do not use the box as an ashtray.

Do not place valuable items in the tray.

SUNGLASSES HOLDER

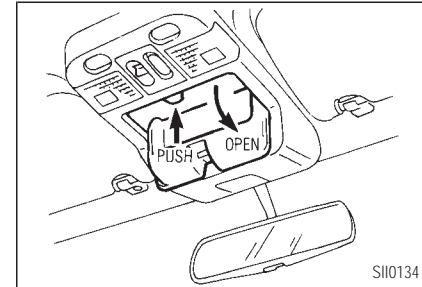

The sunglasses holder can be opened by pushing the button.

WARNING

The sunglasses holder should not be used while driving so full attention may be given to vehicle operation.

INSTRUMENTS AND CONTROLS

CAUTION

- Do not use for anything other than glasses.
- Do not leave glasses in the sunglasses holder while parking in direct sunlight. The heat may damage the glasses.

CUP HOLDERS

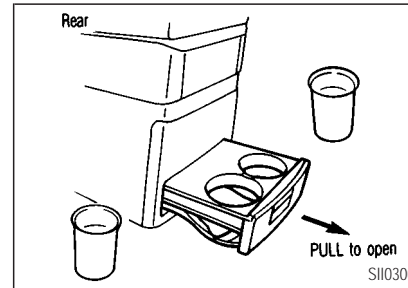
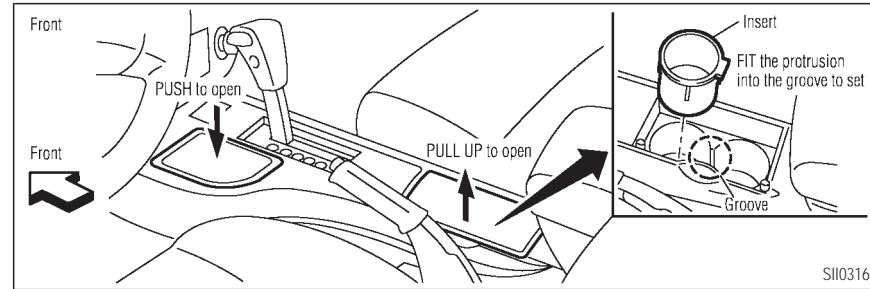

The front cup holder in front of the center console box has an insert that can be removed for larger cups.

Use the insert for the front cup holder so that its upper surface is flush with that of the insert.

INSTRUMENTS AND CONTROLS

WARNING

The cup holder should not be used while driving so full attention may be given to vehicle operation.

CAUTION

- *Avoid abrupt starting and braking when the cup holder is being used to prevent spilling the drink. If the liquid is hot, it can scald you or your passenger.*
- *Use only soft cups in the cup holder. Hard objects can injure you in an accident.*

GLOVE BOX

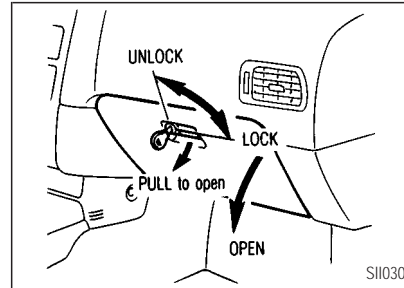

When locking or unlocking the glove box, use the master key.
The glove box may be opened by pulling the handle.

WARNING

Keep the glove box lid closed while driving to help prevent injury in an accident or a sudden stop.

CONSOLE BOX

WARNING

- *The center console box should not be used while driving so full attention may be given to vehicle operation.*
- *Keep the center console box lid closed while driving to prevent injury in an accident or sudden stop.*

Do not place valuable items in the center console box.

INSTRUMENTS AND CONTROLS

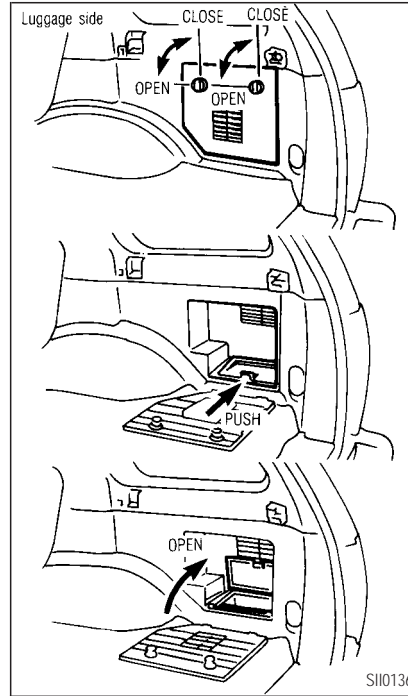
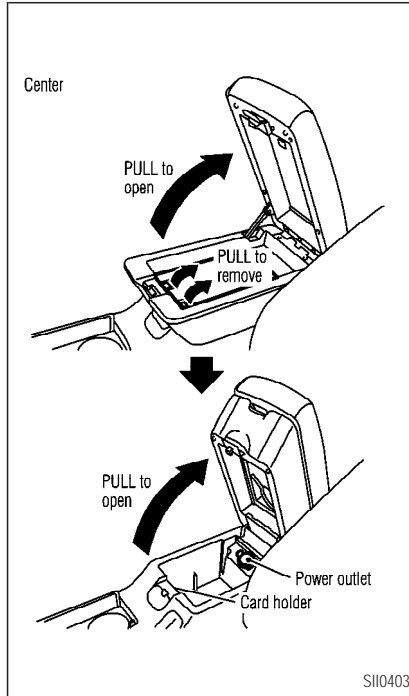

LUGGAGE STORAGE



WARNING

Keep luggage side console box lids closed securely while driving to prevent injury in an accident or sudden stop.

Do not place valuable items in the luggage side console box.

INSTRUMENTS AND CONTROLS

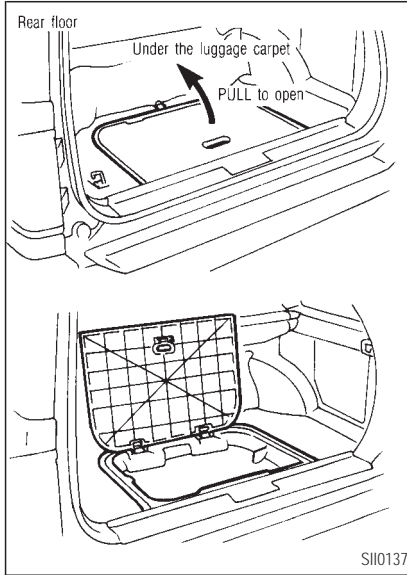

WARNING

- *Make sure the luggage board closes securely.*
- *Do not drive with the board removed.*
- *Properly secure all cargo to help prevent it from sliding or shifting. Do not place cargo higher than the seatbacks. In a sudden stop or collision, unsecured cargo could cause personal injury.*
- *Never allow anyone to ride in the luggage area or on the rear seat when it is in the fold-down position.*
- *It is extremely dangerous to ride in a cargo area inside of a vehicle. In a collision, people riding*

in these areas are more likely to be seriously injured or killed.

- *Do not allow people to ride in any area of your vehicle that is not equipped with seats and seat belts.*

LUGGAGE HOOKS

The luggage hooks can be used to secure cargo with ropes or other types of straps.

WARNING

- *Properly secure all cargo to help prevent it from sliding or shifting. Do not place cargo higher than the seatbacks. In a sudden stop or collision, unsecured cargo could cause personal injury.*

INSTRUMENTS AND CONTROLS

- Use suitable ropes and hooks to secure cargo.
- Never allow anyone to ride in the luggage area. It is extremely dangerous to ride in a cargo area inside of a vehicle. In a collision, people riding in these areas are more likely to be seriously injured or killed.
- Do not allow people to ride in any area of your vehicle that is not equipped with seats and seat belts.
- Be sure everyone in your vehicle is in a seat and using a seat belt properly.

Side finisher

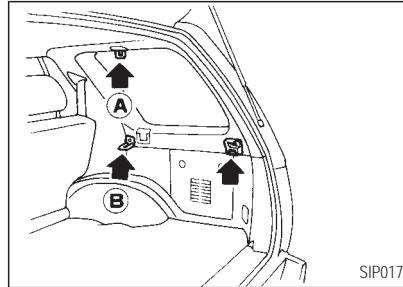

Floor hooks

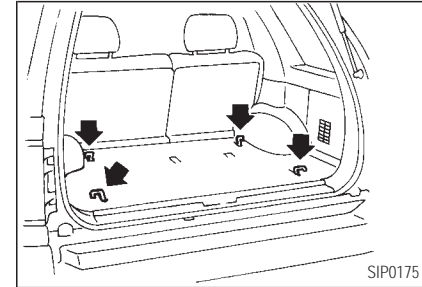

- When hooking on ropes, do not apply a load of more than 22 lb (98 N) to a single hook.
- Do not use the luggage net between the A and B hooks.

INSTRUMENTS AND CONTROLS

CARGO NET

The cargo net keeps packages in the cargo area from moving around while your vehicle is driven.

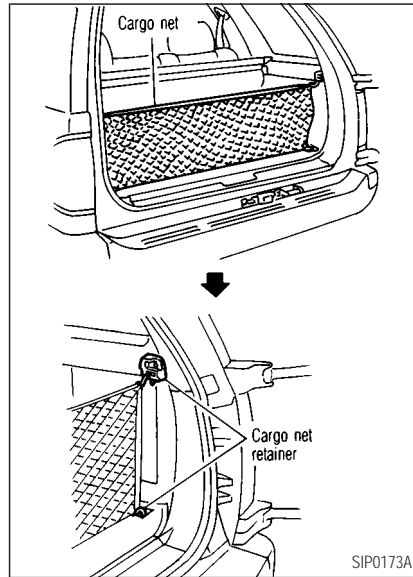

To install the cargo net, attach the four hooks to the four retainers.

To remove the cargo net, detach the four hooks from the cargo net retainers.



WARNING

- *Properly secure all cargo to help prevent it from sliding or shifting. Do not place cargo higher than the seatbacks. In a sudden stop or collision, unsecured cargo could cause personal injury.*
- *Be sure to secure all four hooks into the retainers. The cargo restrained in the net must not exceed 30 lbs. (13.6 kg) or the net may not stay secured.*

TONNEAU COVER

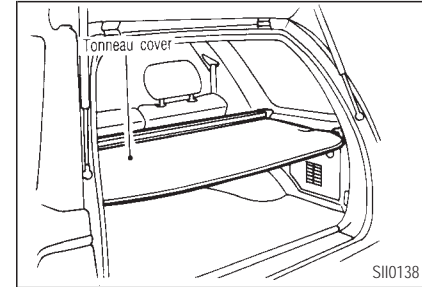

The tonneau cover keeps the luggage compartment contents hidden from the outside.

To open the tonneau cover, pull it out and hang both sides on the hooks. To close the tonneau cover, remove it from the hooks and release it.

INSTRUMENTS AND CONTROLS



WARNING

- *Never put anything on the tonneau cover, no matter how small. Any object on it could cause an injury in an accident or sudden stop.*
- *Do not leave the tonneau cover in the vehicle with it disengaged from the holder.*
- *Properly secure all cargo to help prevent it from sliding or shifting. Do not place cargo higher than the seatbacks. In a sudden stop or collision, unsecured cargo could cause personal injury.*
- *The child restraint top tether strap may be damaged by contact with the tonneau cover or items in the cargo area. Remove the tonneau*

cover from the vehicle or secure it and any cargo. Your child could be seriously injured or killed in a collision if the top tether strap is damaged.

INSTRUMENTS AND CONTROLS

LUGGAGE RACK (if so equipped)

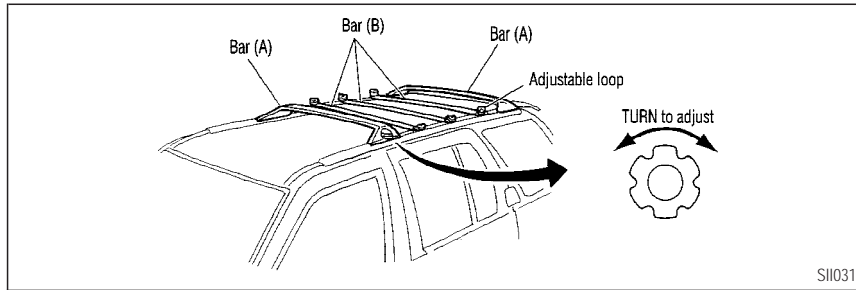

The cross-bars can be adjusted forward and backward. Place your luggage between the bars (A), adjust the bars (A), and secure the luggage with rope to the bars (A). There are also adjustable loops on the side bars for the rope attachment.

Always evenly distribute the luggage on the luggage rack. **Do not load more than 100 lbs. (45 kg).** Be careful that your vehicle does not exceed the Gross Vehicle Weight

Rating (GVWR) or its Gross Axle Weight Rating (GAWR front and rear). The GVWR and GAWR are located on the Safety Compliance Certification Label (located on the driver's door pillar). For more information regarding GVWR and GAWR, refer to "10. Technical and customer information".

Ensure both front and rear bars (A) are installed correctly. See illustration for details.

CAUTION

Use care when placing or removing items from the luggage rack. If you cannot comfortably lift the items onto the luggage rack from the ground, use a ladder or stool.

WINDOWS

WARNING

- *Make sure that all passengers have their hands, etc. inside the vehicle while it is in motion and before closing the windows.*
- *Do not leave children unattended inside the vehicle. They could unknowingly activate switches or*

INSTRUMENTS AND CONTROLS

controls and become trapped in a window. Unattended children could become involved in serious accidents.

POWER WINDOWS

The power windows operate when the ignition key is in the ON position.

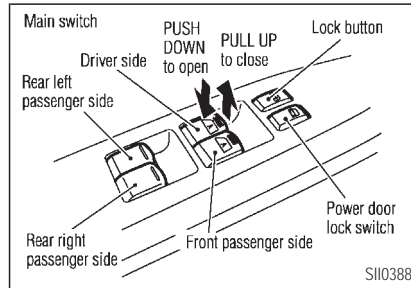

To open or close the window, push down or pull up the switch and hold it. The main

switch (driver side switches) will open or close all the windows.

The power windows are operational for about 45 seconds, even after the ignition key is turned to the OFF position. If the driver's or front passenger's door is opened during this period of about 45 seconds, power to the windows is canceled.

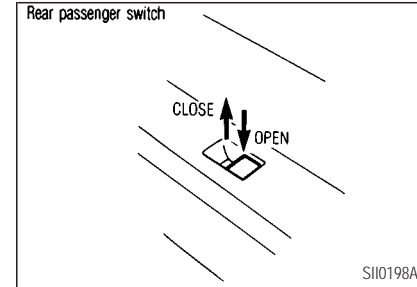
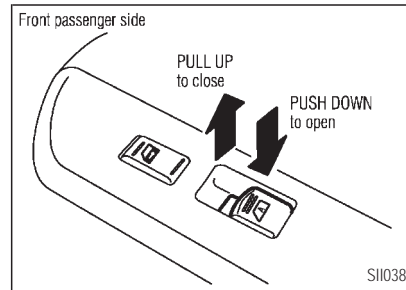

The passenger side switch will open or close only the corresponding window. To open or close the window, hold the switch down or up.

Locking passenger's windows

When the lock button is pushed in, only the driver side window can be opened or closed. Push it in again to cancel.

INSTRUMENTS AND CONTROLS

Automatic operation

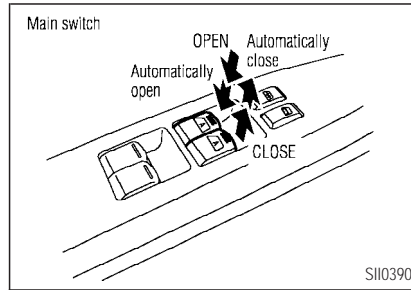

To fully open or close the front windows, completely press down or up the switch and release it; it need not be held. The window will automatically open or close all the way. To stop the window, just pull up or down the switch toward the close or open side.

A light press on the switch will cause the window to open or close until the switch is released.

Auto reverse function (For front windows)

If the control unit detects something caught in the front window as it moves up, the window will be immediately lowered.

The auto reverse function can be activated when the front window is closed by automatic operation when the ignition key is in the ON position or for about 45 seconds after the ignition key is turned to the OFF position.

Depending on the environment or driving conditions, the auto reverse function may be activated if an impact or load similar to something being caught in the window occurs.



WARNING

There are some small distances immediately before the closed position

which cannot be detected. Make sure that all passengers have their hands, etc., inside the vehicle before closing the window.

SUNROOF (if so equipped)

ELECTRIC SUNROOF

The sun roof will only operate when the ignition key is in the ON position.

The automatic sunroof is operational for about 45 seconds, even after the ignition key is turned to the OFF position. If the driver's or front passenger's door is opened during this period of about 45 seconds, power to the sunroof is canceled.

INSTRUMENTS AND CONTROLS

Sliding the sunroof

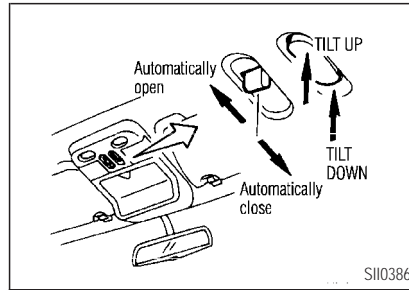

To open the roof, press the switch to the  side.

To close the roof, press the switch to the  side.

The roof will automatically open or close all the way. To stop the roof, just press the switch toward either side.

Auto reverse function (When closing the sunroof)

If the control unit detects something caught in the sunroof as it moves to the front, the sunroof will immediately open backward.

The auto reverse function can be activated when the sunroof is closed by automatic operation when the ignition key is in the ON position or for about 45 seconds after the ignition key is turned to the OFF position.

Depending on the environment or driving conditions, the auto reverse function may be activated if an impact or load similar to something being caught in the sunroof occurs.



WARNING

There are some small distances immediately before the closed position

which cannot be detected. Make sure that all passengers have their hands, etc., inside the vehicle before closing the sunroof.

Tilting the sunroof

To tilt up, first close the sunroof, then press the  side of the tilt switch.

To tilt down the sunroof, press the  side.

Sun shade

Open/close the sun shade by sliding it backward/forward.

The shade will open automatically when the sunroof is opened. However, it must be closed manually.

INSTRUMENTS AND CONTROLS

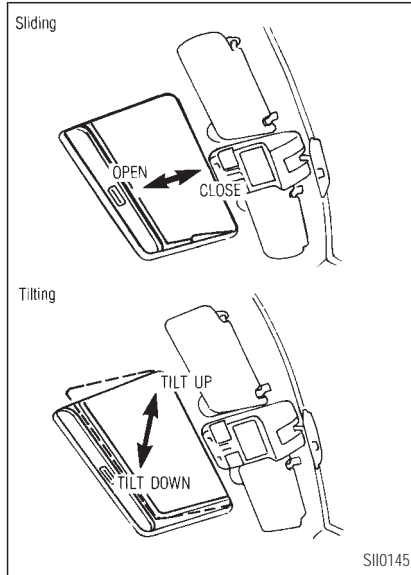

Restarting the sunroof switch

The switch may become inoperable after the battery terminal is disconnected, the electrical supply interrupted and/or some abnormality detected.

Use the following re-set procedure to return sunroof operation to normal.

1. If the sunroof lid is open, push the tilting switch toward tilt DOWN (or the sliding switch toward close) repeatedly to fully close the lid.
2. After the lid has closed all the way, keep pushing the tilting switch toward tilt DOWN (or the sliding switch toward close) for more than 1 second.



WARNING

- *In an accident you could be thrown from the vehicle through an open sunroof. Always use seat belts and child restraints.*
- *Do not allow anyone to stand up or extend any portion of their body out of the opening while the vehicle is in motion or while the sunroof is closing.*



CAUTION

- *Remove water drops, snow, ice or sand from the sunroof before opening.*
- *Do not place any heavy object on the sunroof or surrounding area.*

INSTRUMENTS AND CONTROLS

If the sunroof does not close

Have your INFINITI retailer check and repair the sunroof.

INTERIOR LIGHTS (if so equipped)

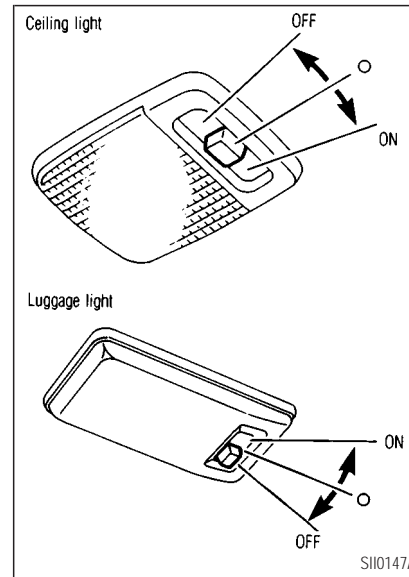

The interior lights have a three position switch.

When the switch is in the center ○ position, the lights will illuminate when a door is opened.

The ceiling light will stay on for about 30 seconds when:

- The driver's door is unlocked by the keyfob, a key or power door lock switch when all doors are locked.
- The driver's door is opened and then closed without the key in the ignition switch.
- The key is removed from the ignition switch while all doors are closed.

The ceiling light will turn off while the 30 second timer is activated when:

- The driver's door is locked either with the keyfob, a key, or the power door lock switch.

INSTRUMENTS AND CONTROLS

- The ignition switch is turned ON.

When the interior light switch or the personal light switch is in the ON position, the interior, personal and vanity mirror lights will automatically turn off 30 minutes after the ignition switch has been turned to the OFF position to save the battery. To turn on the lights again, insert the key into the ignition switch and move it to the ON position.

After the above procedure, the interior, personal, or vanity mirror lights will automatically turn off 30 minutes after the latest operation of the following with the ignition switch in the ACC or OFF position:

- Opening or closing any door
- Locking or unlocking any door with the keyfob, a key or the power door lock switch.
- Inserting or removing a key from the ignition switch

These lights will turn on again when any of the above operations is performed after the lights have turned off automatically. (The lights will turn off 30 minutes after the latest operation of the above as well.)

CAUTION

- ***Do not use for extended periods of time with the engine stopped. This could result in a discharged battery.***
- ***Turn off the interior, personal and vanity mirror lights when you leave the vehicle.***

PERSONAL LIGHT

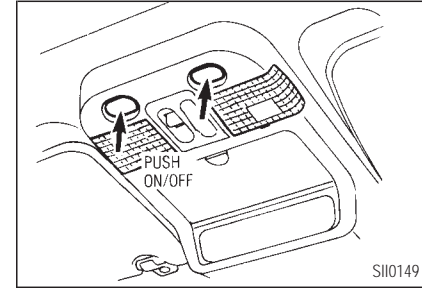

When the interior light switch or the personal light switch is in the ON position, the interior, personal and vanity mirror lights will automatically turn off 30 minutes after the ignition switch has been turned to the OFF position. To turn on the lights again, insert the key into the ignition switch and move it to the ON position.

INSTRUMENTS AND CONTROLS

CAUTION

- *Do not use for extended periods of time with the engine stopped. This could result in a discharged battery.*
- *Turn off the interior, personal and vanity mirror lights when you leave the vehicle.*

VANITY MIRROR LIGHTS

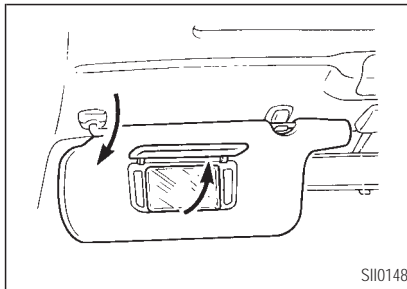

The light on the vanity mirror will turn on when the cover on the vanity mirror is opened.

HomeLink® UNIVERSAL TRANSCEIVER

The HomeLink® Universal Transceiver provides a convenient way to consolidate the functions of up to three individual hand-held transmitters into one built-in device.

The HomeLink® Universal Transceiver power will automatically turn off 30 minutes after the ignition switch has been turned to the off position.

HomeLink® Universal Transceiver:

- Will operate most Radio Frequency (RF) devices such as garage doors, gates, home and office lighting, entry door locks and security systems.
- Is powered by your vehicle's battery. No separate batteries are required. If the vehicle's battery is discharged or is discon-

nected, HomeLink® will retain all programming.

Once the HomeLink® Universal Transceiver is programmed, retain the original transmitter for future programming procedures (i.e., new vehicle purchases). Upon sale of the vehicle, the programmed HomeLink® Universal Transceiver buttons should be erased for security purposes. For additional information, refer to "Programming HomeLink®" later in this section.

INSTRUMENTS AND CONTROLS

WARNING

- *Do not use the HomeLink® Universal Transceiver with any garage door opener that lacks safety stop and reverse features as required by federal safety standards. (These standards became effective for opener models manufactured after April 1, 1982). A garage door opener which cannot detect an object in the path of a closing garage door and then automatically stop and reverse, does not meet current federal safety standards. Using a garage door opener without these features increases the risk of serious injury or death.*
- *During programming, your ga-*

rage door or gate may open or close. Make sure that people and objects are clear of the garage door or gate that you are programming.

- *Your vehicle's engine should be turned off while programming the HomeLink® Universal Transceiver.*

PROGRAMMING HomeLink®

To program your HomeLink Transceiver to operate a garage door, gate, or entry door opener, home or office lighting, you need to be at the same location as the device. Note: Garage door openers (manufactured after 1996) have "rolling code protection". To program a garage door opener equipped with "rolling code protection"; you will need to use a ladder to get up to the garage door opener

motor to be able to access the "smart or learn" program button.

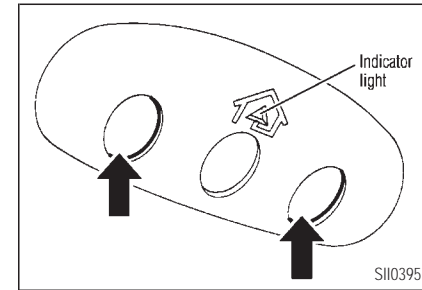

1. To begin, press and hold the 2 outer HomeLink® buttons (to clear the memory) until the indicator light blinks slowly (after 20 seconds). Release both buttons.
2. Position the end of the hand-held transmitter 1-3 inches away from the HomeLink® surface.

INSTRUMENTS AND CONTROLS

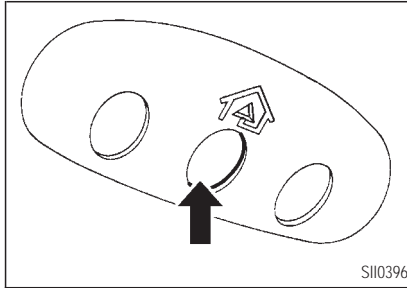

- Using both hands, simultaneously press and hold both the HomeLink® button you want to program and the hand-held transmitter button.
DO NOT release the buttons until step 4 has been completed.
- Hold down both buttons until the indicator light on the HomeLink® flashes, changing from a “slow blink” to a “rapidly flashing blink”. This could take up to 90 seconds. When the indicator light flashes rapidly, both buttons may be released. The rapidly

flashing light indicates successful programming. To activate the garage door or other programmed device, press and hold the programmed HomeLink® button - releasing when the device begins to activate.

- If the indicator light on the HomeLink® blinks rapidly for two seconds and then turns solid, HomeLink® has picked up a “rolling code” garage door opener signal. You will need to proceed with the next steps to train the HomeLink® to complete the programming which may require a ladder and another person for convenience.
- Press and release the “smart” or “learn” program button located on the garage door opener’s motor to activate the “training mode”. This button is usually located near the antenna wire that hangs down from the motor. If the wire originates from under a light lens, you will need to remove the lens to access the program button.

NOTE:

Once you have pressed and released the program button on the garage door opener’s motor and the “training light” is lit, you have 30 seconds in which to perform step 7. Use the help of a second person for convenience to assist when performing this step.

- Quickly within 30 seconds of pressing and releasing the garage door opener program button, firmly press and release the HomeLink® button you’ve just programmed. Press and release the HomeLink® button up to three times to complete the training.
- Your HomeLink® button should now be programmed. (To program the remaining HomeLink® buttons for additional door or gate openers, follow steps 2-8 only.)

NOTE:

Do not repeat step one unless you want

INSTRUMENTS AND CONTROLS

to “clear” all previously programmed HomeLink® buttons).

If you have any questions or are having difficulty programming your HomeLink® buttons, please refer to the HomeLink® web site at: www.homelink.com or call 1-800-662-6200.

PROGRAMMING HomeLink® FOR CANADIAN CUSTOMERS

Prior to 1992, D.O.C. regulations required hand-held transmitters to stop transmitting after 2 seconds. To program your hand-held transmitter to HomeLink®, continue to press and hold the HomeLink® button (note steps 2 through 4 under “Programming HomeLink®”) while you press and re-press (“cycle”) your hand-held transmitter every 2 seconds until the indicator light flashes rapidly (indicating successful programming).

NOTE:

If programming a garage door opener ,

etc., it is advised to unplug the device during the “cycling” process to prevent possible damage to the garage door opener components.

OPERATING THE HomeLink® UNIVERSAL TRANSCEIVER

The HomeLink® Universal Transceiver (once programmed) may now be used to activate the garage door, etc. To operate, simply press the appropriate programmed HomeLink® Universal Transceiver button. The red indicator light will illuminate while the signal is being transmitted.

PROGRAMMING TROUBLE DI- AGNOSIS

If the HomeLink® does not quickly learn the hand-held transmitter information:

- replace the hand-held transmitter batteries with new batteries.
- position the hand-held transmitter with its

battery area facing away from the HomeLink® surface.

- press and hold both the HomeLink® and hand-held transmitter buttons without interruption.
- position the hand-held transmitter 2 to 5 inches (50 to 127 mm) away from the HomeLink® surface. Hold the transmitter in that position for up to 15 seconds. If HomeLink® is not programmed within that time, try holding the transmitter in another position - keeping the indicator light in view at all times.

If you continue to have programming difficulties, please contact the INFINITI Consumer Affairs Department. The phone numbers are located in the Foreword of this Owner's Manual.

CLEARING THE PROGRAMMED INFORMATION

Individual buttons cannot be cleared, however

INSTRUMENTS AND CONTROLS

to clear all programming, press and hold the two outside buttons and release when the indicator light begins to flash (approximately 20 seconds).

REPROGRAMMING A SINGLE HomeLink® BUTTON

To reprogram a HomeLink® Universal Transceiver button, complete the following.

1. Press and hold the desired HomeLink® button. **Do not** release the button until step 4 has been completed.
2. When the indicator light begins to flash slowly (after 20 seconds), position the hand-held transmitter 2 to 5 inches (50 to 127 mm) away from the HomeLink® surface.
3. Press and hold the hand-held transmitter button.
4. The HomeLink® indicator light will flash, first slowly and then rapidly. When the

indicator light begins to flash rapidly, release both buttons.

The HomeLink® Universal Transceiver button has now been reprogrammed. The new device can be activated by pushing the HomeLink® button that was just programmed. This procedure will not affect any other programmed HomeLink® buttons.

IF YOUR VEHICLE IS STOLEN

If your vehicle is stolen, you should change the codes of any non-rolling code device that has been programmed into HomeLink®. Consult the Owner's Manual of each device or call the manufacturer or dealer of those devices for additional information.

When your vehicle is recovered, you will need to reprogram the HomeLink® Universal Transceiver with your new transmitter information.

FCC Notice:

This device complies with FCC rules part 15. Operation is subject to the following two conditions: (1) This device may not cause harmful interference and (2) This device must accept any interference that may be received, including interference that may cause undesired operation.

The transmitter has been tested and complies with FCC and DOC/MDC rules. Changes or modifications not expressly approved by the party responsible for compliance could void the user's authority to operate the device.

DOC: ISTC 1763K1313

FCC I.D.: CB2V67690

3 PRE-DRIVING CHECKS AND ADJUSTMENTS

Keys	3-2	Key operation	3-12
Doors	3-3	Fuel filler lid.....	3-13
Locking with key	3-3	Opener operation.....	3-13
Front window operating with key	3-3	Fuel filler cap.....	3-13
Locking with inside lock knob	3-4	Steering wheel	3-15
Locking with power door lock switch....	3-4	Tilt operation.....	3-15
Child safety rear door lock.....	3-4	Sun visors.....	3-16
Remote keyless entry system.....	3-5	Using the sun visors	3-16
How to use remote keyless entry		Mirrors.....	3-17
system.....	3-6	Inside mirror	3-17
Battery replacement.....	3-9	Outside mirrors	3-17
Hood	3-10	Automatic seat positioner (if so	
Back door	3-11	equipped)	3-18
Key operation	3-11	Automatic seat positioner operation	3-18
Glass hatch.....	3-12	Cancel switch	3-20
Opener operation.....	3-12		

PRE-DRIVING CHECKS AND ADJUSTMENTS

KEYS

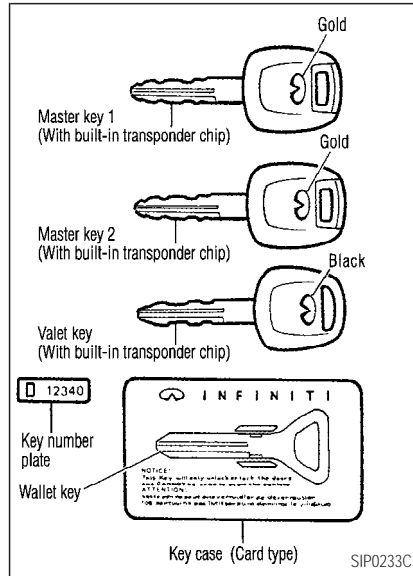

You can only drive your vehicle using the master or valet keys which are registered to

the Infiniti Vehicle Immobilizer System components in your vehicle. These keys have a transponder chip in the key head. (The wallet key cannot be used to drive your vehicle.)

The master key and wallet key can be used for all locks.

When the key case with the wallet key is placed into your wallet, be careful not to apply excessive force to the wallet as it or other cards could be damaged.

The valet key cannot be used for the trunk lid or glove box locks.

To protect belongings when you leave a key with someone, give them the valet key only.

Never leave these keys in the vehicle.

Record the key number on the key number plate supplied with your keys and keep it in a safe place (such as your wallet), not in the vehicle. INFINITI does not record any key number so it is very important to keep track of

your key number plate.

A key number is only necessary when you have lost all keys and do not have one to duplicate from. If you still have a key, this key can be duplicated by your INFINITI retailer.

Infiniti Vehicle Immobilizer System KEY - Master and Valet keys:

The key number is necessary when you need extra Infiniti Vehicle Immobilizer System keys. As many as 5 Infiniti Vehicle Immobilizer System keys can be used with one vehicle. New keys must be registered to the Infiniti Vehicle Immobilizer System components in your vehicle by your INFINITI retailer. At this time, you should bring all Infiniti Vehicle Immobilizer System keys that you have to your INFINITI retailer for registration. This is because the registration process will erase all memory of the Infiniti Vehicle Immobilizer System components.

PRE-DRIVING CHECKS AND ADJUSTMENTS

DOORS



WARNING

- *Always have the doors locked while driving. Along with the use of seat belts, this provides greater safety in the event of an accident by helping to prevent persons from being thrown from the vehicle. This also helps keep children and others from unintentionally opening the doors, and will help keep out intruders.*
- *Before opening any door, always look for and avoid oncoming traffic.*
- *Do not leave children unattended inside the vehicle. They could unknowingly activate switches or*

controls. Unattended children could become involved in serious accidents.

LOCKING WITH KEY

Power

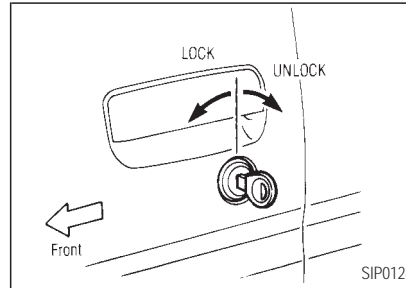

The power door lock system allows you to lock or unlock all doors including the back door simultaneously.

- Turning the door key to the front of the

vehicle will lock all doors.

- Turning the door key one time to the rear of the vehicle will unlock the corresponding door. From that position, returning the key to neutral (where the key can only be removed and inserted) and turning it to the rear again within 5 seconds will unlock all doors.

FRONT WINDOW OPERATING WITH KEY

Turn the driver's door key to the unlock position and hold for about 1 second. The front windows will begin to open.

To stop opening, turn the key to the neutral position.

To close the front windows with the key cylinder, turn the key to the lock position and hold for about 1 second.

To stop closing, turn the key to the neutral position.

PRE-DRIVING CHECKS AND ADJUSTMENTS

LOCKING WITH INSIDE LOCK KNOB

Power

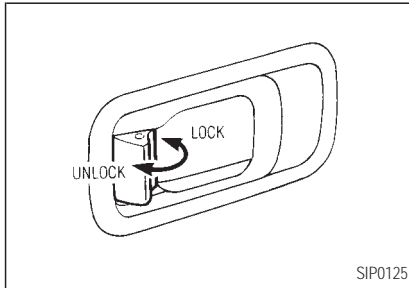

Pushing or pulling the front door inside lock knob to the lock or unlock position will lock or unlock the corresponding door.

To lock from the outside without a key, move the inside lock knob to the LOCK position. Then close the door. When locking the door this way, be certain not to leave the key inside the vehicle.

LOCKING WITH POWER DOOR LOCK SWITCH

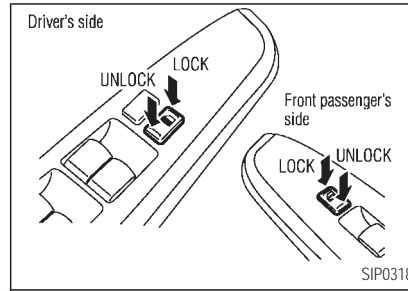

- Operating the power door lock switch will lock or unlock all doors including the back door simultaneously.

All door locks will be engaged when the power door lock switch is moved to the LOCK position with the driver's or front passenger's door open. Then close the door and all doors will be locked.

When the power door lock switch is moved to

the LOCK position while either front door is open and a key is in the ignition switch, all doors will lock once and then unlock automatically.

CHILD SAFETY REAR DOOR LOCK

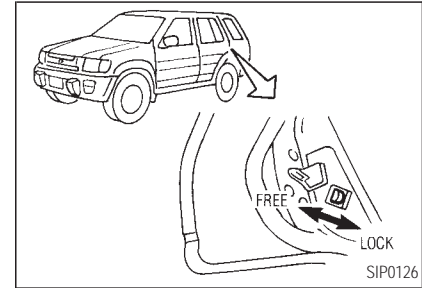

Child safety locking helps prevent doors from being opened accidentally, especially when small children are in the vehicle.

When the lever is in the lock position,

PRE-DRIVING CHECKS AND ADJUSTMENTS

the rear door can be opened only from the outside.

REMOTE KEYLESS ENTRY SYSTEM

It is possible to lock/unlock all doors and activate the panic alarm by using the keyfob from outside the car.

Before locking the doors, make sure the key is not left in the vehicle.

The keyfob can operate at a distance of approximately 33 ft (10 m) from the vehicle. (The effective distance depends upon the conditions around the vehicle.)

As many as four keyfobs can be used with one vehicle. For information concerning the purchase and use of additional keyfobs, contact your INFINITI retailer.

The keyfob will not function when:

- the battery is dead,
- the distance between the vehicle and the

keyfob is over 33 ft (10 m).

The panic alarm will not activate when the key is in the ignition switch.



CAUTION

The following conditions or occurrences will damage the keyfob.

- *Do not allow the keyfob to become wet.*
- *Do not drop the keyfob.*
- *Do not strike the keyfob sharply against another object.*
- *Do not place the keyfob for an extended period in an area where temperatures exceed 140°F (60°C).*

If a keyfob is lost or stolen, INFINITI recommends erasing the ID code of

that keyfob. This will prevent the keyfob from unauthorized use to unlock the vehicle. For information regarding the erasing procedure, please contact an authorized INFINITI retailer.

PRE-DRIVING CHECKS AND ADJUSTMENTS

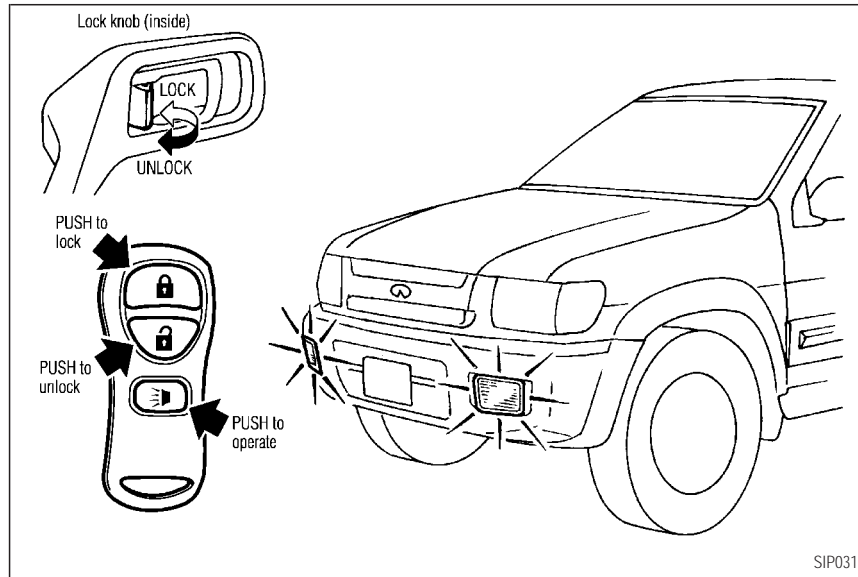

HOW TO USE REMOTE KEYLESS ENTRY SYSTEM

Setting hazard indicator and horn mode

This vehicle is set in hazard indicator and horn mode when you first receive the vehicle.

In hazard indicator and horn mode, when the LOCK button is pushed, the hazard indicator flashes twice and the horn chirps once. When the UNLOCK button is pushed, the hazard indicator flashes once.

If hazard indicator and horn mode is not necessary, you can switch to hazard indicator only mode by following the switching procedure below.

In hazard indicator only mode, when the LOCK button is pushed, the hazard indicator flashes twice. When the UNLOCK button is pushed, neither the hazard indicator nor the horn operates.

PRE-DRIVING CHECKS AND ADJUSTMENTS

(Switching procedure)

Press and hold the LOCK and UNLOCK buttons on the keyfob simultaneously for at least 2 seconds to switch from one to the other.

When pushing the buttons to set hazard indicator only mode, the hazard indicator flashes 3 times.

When pushing the buttons to set hazard indicator and horn mode, the hazard indicator flashes once and the horn chirps once.

(Operations)

OPERATION GUIDE				
MODE (Push "LOCK" and "UNLOCK" buttons for more than 2 seconds to switch)		Switching indicator	LOCK	UNLOCK
Hazard indicator and horn	→ HAZARD INDICATOR ONLY	HAZARD – 3 times	HAZARD – twice	No operation
Hazard indicator only	→ HAZARD INDICATOR AND HORN	HAZARD – once HORN – once	HAZARD – twice HORN – once	HAZARD – once

SIP0289

Locking doors

1. Remove the ignition key.*1
2. Close all of the doors.*2
3. Push the LOCK button on the keyfob.
4. All of the doors lock.

All of the doors will lock when the LOCK

button on the keyfob is pushed even though a door remains open and/or the ignition key is in the ON position.

5. The hazard indicator flashes twice and the horn chirps once.

When the LOCK button is pushed with all doors locked, the hazard indicator flashes

PRE-DRIVING CHECKS AND ADJUSTMENTS

twice and the horn chirps once as a reminder that the doors are already locked.

*1: Doors lock with the keyfob while a key is in the ignition switch. However, the panic alarm will not activate when the ignition switch is in the ACC or ON position.

*2: Doors lock with the keyfob while any door is open. However, hazard and horn chirp mode will not function.

Unlocking doors

1. Push the UNLOCK button on the keyfob.
 - Only the driver's door unlocks
 - The hazard indicator flashes once if all doors are completely closed.
 - The interior light turns on and the light timer activates for 30 seconds when the switch is in the center ○ position.
2. Push the UNLOCK button on the keyfob again within 5 seconds.

- All doors unlock
- The hazard indicator flashes once if all doors are completely closed.

The interior light can be turned off without waiting for 30 seconds by turning the ignition switch to the ON position or locking the doors with the keyfob.

Opening the front window

Push the UNLOCK button on the keyfob.

The driver's door will unlock.

Continue to press the UNLOCK button for 3 seconds. The driver's and front passenger's windows will be lowered.

Continue to press the UNLOCK button until windows are fully open.

To stop lowering the windows, release the UNLOCK button.

To start lowering the windows, press the UNLOCK button again for 3 more seconds.

This function will operate after the ignition switch is off and 45 seconds passed or either the front door is opened.

Using the panic alarm

If you are near your vehicle and feel threatened, you may activate the panic alarm to call attention as follows:

1. Push the PANIC button on the keyfob for longer than 0.5 seconds.
2. The panic alarm and headlight will stay on for 30 seconds.
3. The panic alarm stops when:
 - It has run for 30 seconds, or
 - The LOCK or the UNLOCK button is pressed, or
 - The PANIC button is pushed on the keyfob.

PRE-DRIVING CHECKS AND ADJUSTMENTS

BATTERY REPLACEMENT

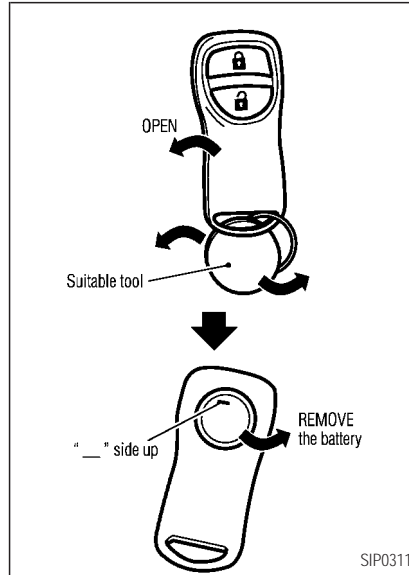

Replace the battery as follows:

1. Open the lid using a suitable tool.
2. Replace the battery with a new one.
Recommended battery: CR2025 or equivalent

Make sure that the \oplus side faces the bottom case.

3. Close the lid securely.
4. Push the keyfob button two or three times to check its operation.

See your INFINITI retailer if you need any assistance for replacement.

If the battery is removed for any reason other than replacement, perform step 4 above.

- Be careful not to touch a circuit plate and a battery terminal.
- An improperly disposed battery can harm the environment. Always con-

firm local regulations for battery disposal.

- The keyfob is water-proof. However, if it does get wet, immediately wipe completely dry.
- When changing batteries, do not let dust or oil get on the keyfob.

FCC Notice:

Changes or modifications not expressly approved by the manufacturer compliance could void the user's authority to operate the equipment.

This device complies with Part 15 of the FCC Rules and RSS-210 of Industry Canada.

Operation is subject to the following two conditions: (1) This device may not cause harmful interference, and (2) this device must accept any interference received, including interference that may

PRE-DRIVING CHECKS AND ADJUSTMENTS

cause undesired operation of the device.

HOOD

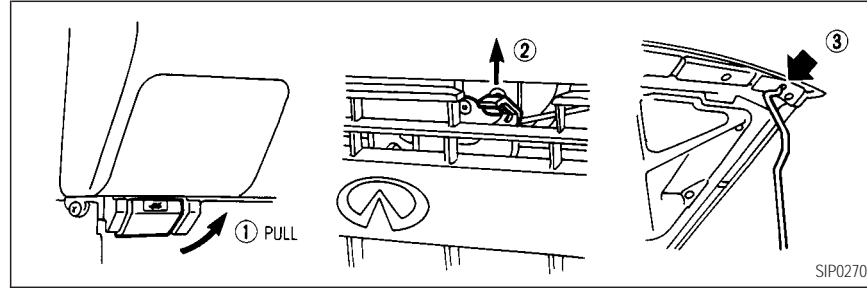

1. Pull the hood lock release handle located below the instrument panel; the hood will then spring up slightly.
2. Pull the lever at the front of the hood with your fingertips and raise the hood.
3. Insert the assist bar into the slot in the front edge of the hood.
4. When closing the hood, reset the assist bar to its original position, then slowly close the hood and make sure it locks into place.



WARNING

- ***Make sure the hood is completely closed and latched before driving. Failure to do so could cause***

PRE-DRIVING CHECKS AND ADJUSTMENTS

the hood to fly open and result in an accident.

- *If you see steam or smoke coming from the engine compartment, to avoid injury do not open the hood.*

BACK DOOR KEY OPERATION

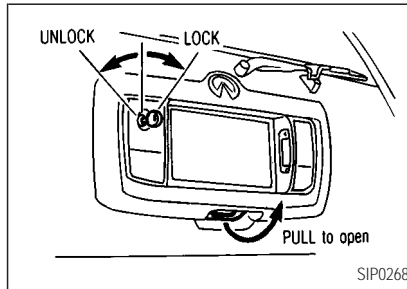

WARNING

Do not drive with the back door open. This could allow dangerous exhaust gases to be drawn into the vehicle. See "Precaution when starting and driving" in the "5. Starting and driving" section for exhaust gas.

1. Turn the key counterclockwise to unlock the back door.

Turning the back door key one time counterclockwise will unlock the back door. From that position, returning the key to neutral (where the key can only be removed and inserted) and turning it to the rear again within 5 seconds will unlock all doors.

2. Pull the opener handle to open the back door.

3. To lock the back door, push it down firmly and turn the key clockwise.

The power door lock system allows you to lock or unlock all doors including the back door simultaneously.

- Turning the front door key to the front of the vehicle will lock all doors including the back door.
- Turning the front door key one time to the rear of the vehicle will unlock the corresponding door. From that position, returning the key to Neutral (where the key can only be removed and inserted) and turning it to the rear again within 5 seconds will unlock all doors.

PRE-DRIVING CHECKS AND ADJUSTMENTS

GLASS HATCH

WARNING

Do not drive with the glass hatch open. This could allow dangerous exhaust gases to be drawn into the vehicle. See "Precaution when starting and driving" in the "5. Starting and driving" section for exhaust gas.

OPENER OPERATION

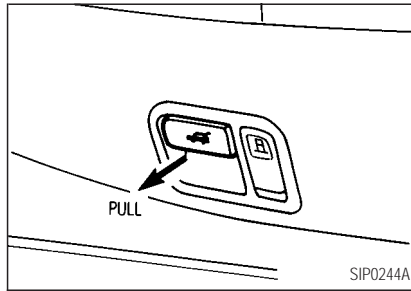

The glass hatch release handle is located under the driver's arm rest.

To open the glass hatch from the inside, pull the glass hatch opener handle.

The glass hatch will not open while the rear window wiper is operating. Open the glass hatch after the rear window wiper returns to the STOP position. To close the glass hatch, push the glass hatch down securely.

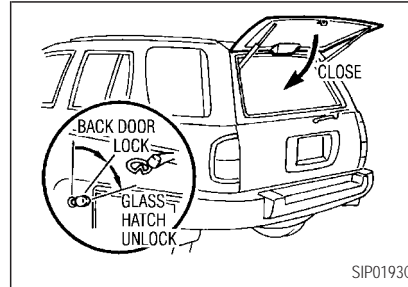

KEY OPERATION

To open the glass hatch, turn the key fully clockwise and pull the handle. To close, lower and push the glass hatch down securely.

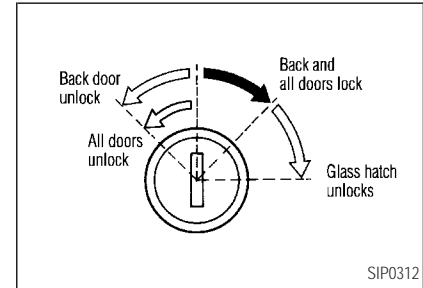

Other key operations

- Turning the key clockwise locks all doors including the back door.
- Turning the key counterclockwise unlocks the back door.
- Turning the key counterclockwise again

PRE-DRIVING CHECKS AND ADJUSTMENTS

within 5 seconds unlock all doors.

CAUTION

Do not open the glass hatch unless the wiper is in the stowed position.

FUEL FILLER LID OPENER OPERATION

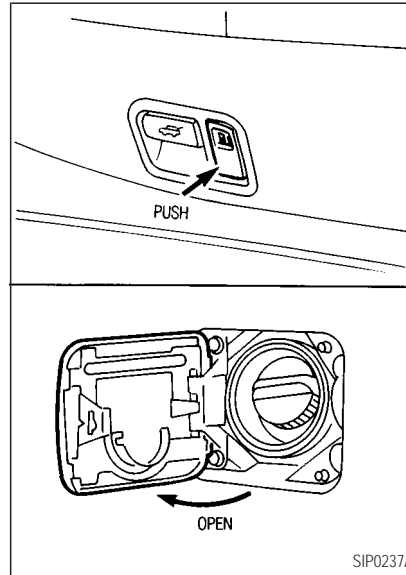

The fuel filler lid release switch is located under the driver's door arm rest.

To open the fuel filler lid, push the opener switch. To lock, close the fuel filler lid securely.

FUEL FILLER CAP

WARNING

- *Gasoline is extremely flammable and highly explosive under certain conditions. You could be burned or seriously injured if it is misused or mishandled. Always stop engine and do not smoke or allow open flames or sparks near the vehicle when refueling.*
- *Fuel may be under pressure. Turn the cap one-half turn, and wait for any hissing sound to stop to pre-*

PRE-DRIVING CHECKS AND ADJUSTMENTS

vent fuel from spraying out and possible personal injury. Then remove cap.

- Do not attempt to top off the fuel tank often the fuel pump nozzle shuts off automatically. Continued refueling may cause fuel overflow, resulting in fuel spray and possibly a fire.
- Only use an original equipment type fuel filler cap as a replacement. It has a built-in safety valve needed for proper operation of the fuel system and emission control system. An incorrect cap can result in a serious malfunction and possible injury or it may cause the MIL to illuminate.
- Never pour fuel into the throttle body to attempt to start your ve-

hicle.

- Do not fill a portable fuel container in the vehicle or trailer. Static electricity can cause an explosion of flammable liquid, vapor or gas in any vehicle or trailer. To reduce the risk of serious injury or death when filling portable fuel containers:
 - Always place the container on the ground when filling.
 - Do not use electronic devices while filling.
 - Keep the pump nozzle in contact with the container while you are filling it.
 - Use only approved portable fuel containers for flammable liquid.



CAUTION

- If fuel is spilled on the car body, flush it away with water to avoid paint damage.
- Tighten until the fuel filler cap clicks. Failure to tighten the fuel filler cap properly may cause the malfunction indicator lamp (MIL) to illuminate. If the lamp illuminates because the fuel filler cap is loose or missing, tighten or install the cap and continue to drive the vehicle. The lamp should turn off after a few driving trips. If the lamp does not turn off after a few driving trips, have the vehicle inspected by an authorized INFINITI retailer.

PRE-DRIVING CHECKS AND ADJUSTMENTS

- For additional information, see “Malfunction indicator lamp (MIL)” in the “2. Instruments and controls” section.

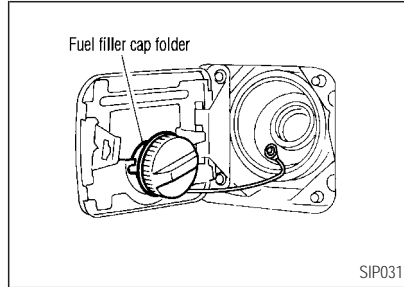
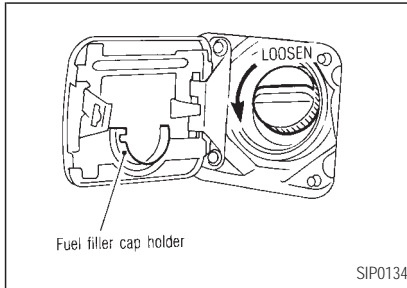

Put the fuel filler cap on the cap holder while refueling.

The fuel filler cap is a ratcheting type. Retighten the cap clockwise until ratcheting clicks are heard.

STEERING WHEEL

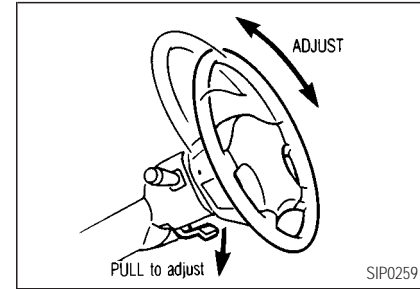

TILT OPERATION

Push the lock lever and while holding it down, adjust the steering wheel up or down to the desired position.



WARNING

Do not adjust the steering wheel while driving. You could lose control

PRE-DRIVING CHECKS AND ADJUSTMENTS

of your vehicle and cause an accident.

SUN VISORS

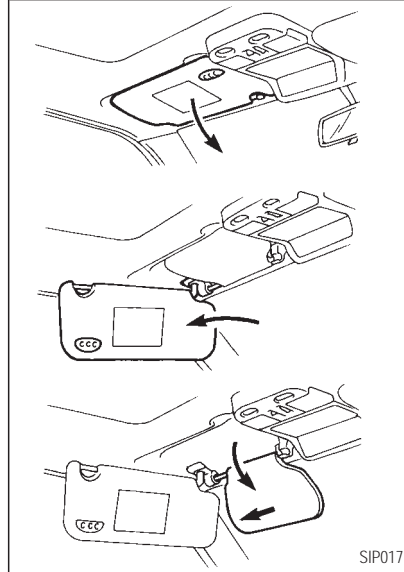

USING THE SUN VISORS

1. To block out glare from the front, swing down the main sun visor.
2. To block glare from the side, remove the main sun visor from the center mount and swing it to the side.
3. Then, to block glare from the front too, swing down the sub-sun visor.
4. To adjust the glare block position, slide the sub-sun visor to the left.



CAUTION

- Do not store the main sun visor before storing the sub-sun visor.
- Do not pull the sub-sun visor forcibly downwards.

PRE-DRIVING CHECKS AND ADJUSTMENTS

MIRRORS

INSIDE MIRROR

The night position will reduce glare from the headlights of vehicles behind you at night.

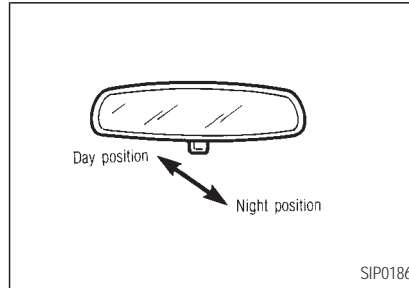

WARNING

Use the night position only when necessary, because it reduces rear view clarity.

OUTSIDE MIRRORS

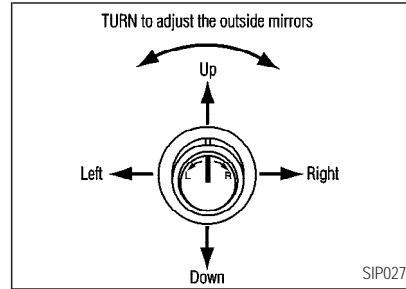

WARNING

Objects viewed in the outside mirror on the passenger side are closer than they appear. Be careful when moving to the right. Using only this mirror could cause an accident. Use inside mirror or glance over your shoulder to properly judge distances to other

objects.

The outside mirror will operate only when the ignition switch is in the ACC or ON position.

Turn the control knob to the right or left to select the right or left outside mirror, then adjust.

Foldable outside mirrors

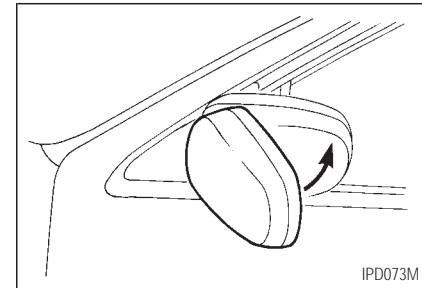

Push the outside mirror backward to fold it.

PRE-DRIVING CHECKS AND ADJUSTMENTS

AUTOMATIC SEAT POSITIONER (if so equipped)

AUTOMATIC SEAT POSITIONER OPERATION

This system is designed so that the driver's seat will automatically move when the automatic transmission selector lever is in the P (Park) position. This allows the driver to get into and out of the driver's seat more easily.

When one of the following conditions is met, the driver's seat will slide backward:

- When the key is removed from the ignition switch.
- When the driver's door is opened with the key turned to ACC or LOCK.
- When the key is turned from ON to LOCK with the driver's door open.

When one of the following conditions is met, the driver's seat will return to the positions before being set.

- When the key is inserted into the ignition switch.
- When the driver's door is closed with the key turned to ACC or LOCK.
- When the key is turned to ON.

Procedure for storing memory

Two positions can be stored in the automatic drive positioner memory. **Follow these procedures to use the memory system.**

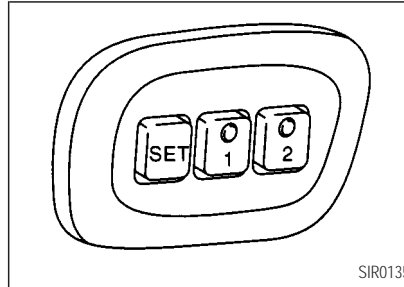

1. Set the automatic transmission selector

lever to the P (Park) position.

2. Turn the ignition ON.
3. Adjust the driver's seat to the desired positions by manually operating each adjusting switch. For additional information, see "Seats" in the "1. Seats, restraints and supplemental air bag systems" section.

During this step, do not turn the ignition to any positions other than ON.

4. Push the SET switch and, within 5 seconds, push the memory switch 1 or 2 fully for at least 1 second.

The indicator light for the pushed memory switch will come on and stay on for approximately 5 seconds after pushing the switch. After the indicator light goes off, the selected positions are stored in the selected memory (1 or 2).

If memory is stored in the same memory

PRE-DRIVING CHECKS AND ADJUSTMENTS

switch, the previous memory will be deleted.

Confirming memory storage

- Turn the ignition ON and push the SET switch. If the main memory has not been stored, the indicator light will come on for approximately 0.5 seconds. When the memory has stored the position, the indicator light will stay on for approximately 5 seconds.
 - If the battery cable is disconnected, or if the fuse blows, the memory will be canceled. In such a case, reset the desired positions using the following procedures.
1. Open and close the driver's door more than two times with the ignition key in the LOCK position.
 2. Reset the desired position using the previous procedure.

Selecting the memorized position

1. Set the automatic transmission selector lever to the P (Park) position.
2. Turn the ignition ON.
3. Push the memory switch 1 or 2 fully for at least 1 second.

The driver's seat will move to the memorized position with the indicator light flashing, and then the light will stay on for approximately 5 seconds.

When the memory switch 1 or 2 is pushed with the driver's door open and then the key inserted into the ignition switch within approximately 1 minute, the driver's seat will move to the memorized position.

System operation

The automatic drive positioner system will not work or will stop operating under the following conditions:

- when the vehicle speed is above 4 MPH (7 km/h).
- when any two or more of the memory switches are simultaneously pushed while the automatic drive positioner is operating.
- when the adjusting switch for the driver's seat is turned on while the automatic drive positioner is operating.
- when the cancel switch located on the instrument panel is pushed to cancel.
- when the memory switch 1 or 2 is not pushed for at least 1 second.
- when the seat has been already moved to the memorized position.
- when no seat position is stored in the memory switch.

PRE-DRIVING CHECKS AND ADJUSTMENTS

CANCEL SWITCH

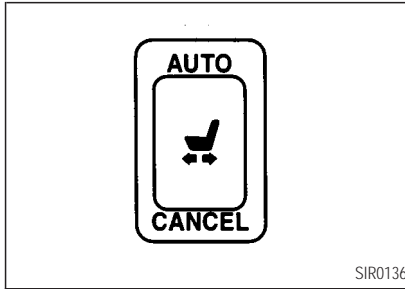

When the CANCEL side of the switch is pushed, the automatic drive positioner system will not function.

When the AUTO side of the switch is pushed, the system will function.

4 HEATER, AIR CONDITIONER AND AUDIO SYSTEMS

Ventilators.....	4-2	AM radio reception.....	4-8
Heater and air conditioner (Automatic).....	4-3	Audio operation precautions	4-8
Automatic operation.....	4-4	FM-AM radio with cassette player	4-10
Manual operation	4-5	FM-AM radio with cassette player and compact disc (CD) player/CD changer	4-16
Operating tips.....	4-5	CD care and cleaning.....	4-22
In-cabin microfilter.....	4-6	Steering wheel switch for audio control (if so equipped)	4-23
Servicing air conditioner.....	4-6	Antenna	4-24
Audio system.....	4-6	Car phone or CB radio	4-25
Radio	4-6		
FM radio reception	4-7		

HEATER, AIR CONDITIONER AND AUDIO SYSTEMS

VENTILATORS

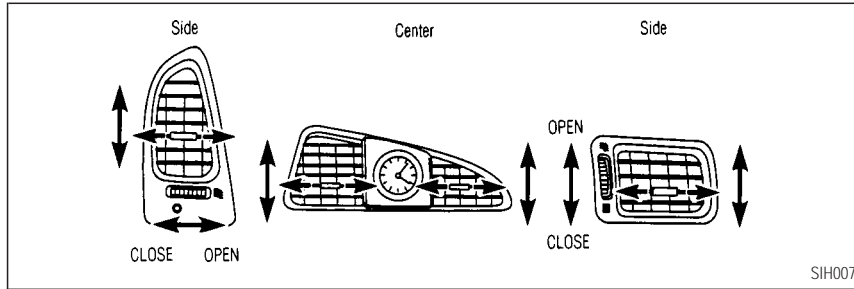

Open or close, and adjust the air flow direction of ventilators.

☒ : This symbol indicates that the vents are closed when the vent switch is moved to the left.

≡ : This symbol indicates that the vents are open when the vent switch is moved to the right.

HEATER, AIR CONDITIONER AND AUDIO SYSTEMS

HEATER AND AIR CONDITIONER (Automatic)

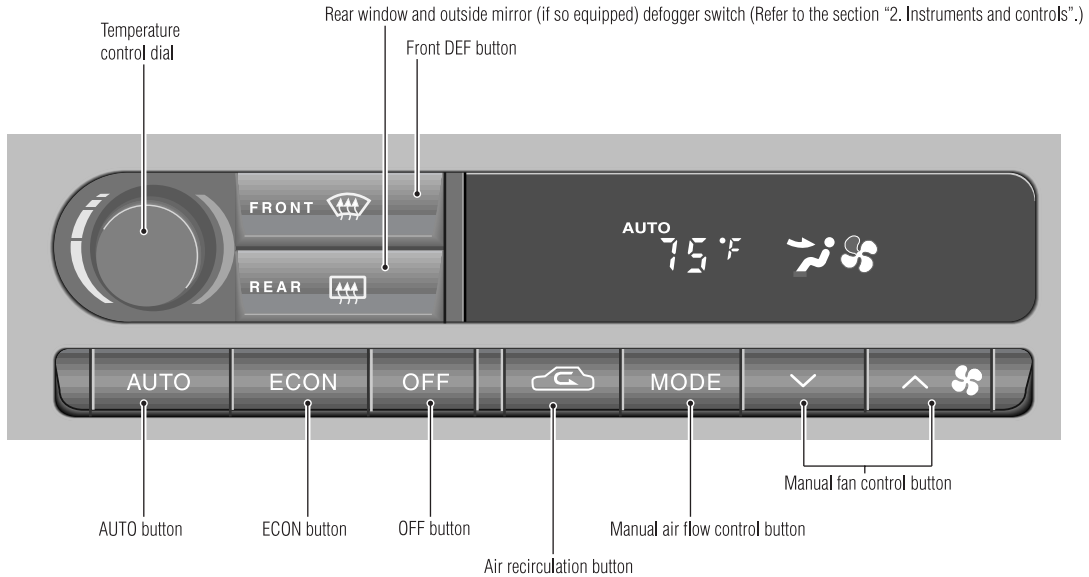

HEATER, AIR CONDITIONER AND AUDIO SYSTEMS

Start the engine and operate the controls to activate the air conditioner.



WARNING

- *The air conditioner cooling function operates only when the engine is running.*
- *Do not leave children or adults who would normally require the support of others alone in your vehicle. Pets should not be left alone either. On hot, sunny days, temperatures in a closed vehicle could quickly become high enough to cause severe or possibly fatal injuries to people or animals.*
- *Do not use the recirculation mode for long periods as it may cause the interior air to become stale and the windows to fog up.*

- *Positioning of the heater and air conditioner controls should not be done while driving so full attention may be given to vehicle operation.*

AUTOMATIC OPERATION

Cooling and/or dehumidified heating (AUTO)

This mode may be normally used all year round as the system automatically works to keep a constant temperature. Air flow distribution and fan speed are also controlled automatically.

1. Push the AUTO button on. (AUTO will be displayed.)
 2. Turn the temperature control dial to the right or left to set the desired temperature.
- Adjust the temperature control dial to about 75°F (24°C) for normal operation.

- The temperature of the passenger compartment will be maintained automatically. Air flow distribution and fan speed are also controlled automatically.





Heating (ECON)

The air conditioner does not activate. When you need to heat only, use this mode.

1. Push the ECON (Economy) button on. (ECON will be displayed.)
 2. Turn the temperature control dial to the right or left to set the desired temperature.
- The temperature of the passenger compartment will be maintained automatically. Air flow distribution and fan speed are also controlled automatically.
 - Do not set the temperature lower than the outside air temperature. Otherwise the system may not work properly.
 - Not recommended if windows fog up.

HEATER, AIR CONDITIONER AND AUDIO SYSTEMS

Dehumidified defogging

1. Push the DEF button  on. (The indicator light on the button will come on.)
 2. Turn the temperature set button to the right or left to set the desired temperature.
- To quickly remove ice or fog from the outside of the windows, push the manual fan control button  and set to the maximum position  .
 - As soon as possible after the windshield is clean, push the AUTO button to return to the auto mode.
 - When the DEF button  is pushed, the air conditioner will automatically be turned on at outside temperatures above 23°F (-5°C) to defog the windshield, and the air recirculation mode will automatically be turned off.

Outside air is drawn into the passenger

compartment to improve the defogging performance.

MANUAL OPERATION

Fan speed control

Push the fan control button  to manually control the fan speed.

Push the AUTO button to return to automatic control of the fan speed.

Air recirculation

Push the air recirculation button  to recirculate interior air inside the vehicle. The indicator light on the switch will come on.

Push it again to make the air inlet controlled automatically (FRESH, REC/FRE and RECIRCULATION). The indicator will go out.

The air recirculation button will not be activated when the air conditioner is in DEF mode.

Air flow control

Pushing the manual air flow control button selects the air outlet to:

: Air flows from center and side ventilators.

: Air flows from center and side ventilators and foot outlets.

: Air flows mainly from foot outlets.

: Air flow from defroster and foot outlets.

To turn system off

Push the OFF button.

OPERATING TIPS

- When the engine coolant temperature and outside air temperature are low, the air flow from the foot outlets may not operate for 0 to 126 seconds. This is not a malfunction. After the coolant temperature warms up, air flow from the foot outlets

HEATER, AIR CONDITIONER AND AUDIO SYSTEMS

will operate normally.

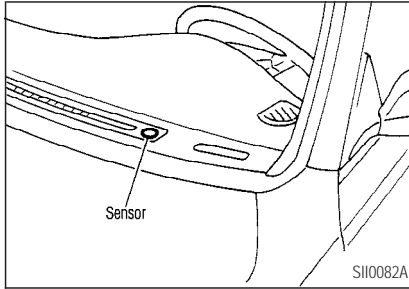

The sensor on the instrument panel helps maintain a constant temperature. Do not put anything on or around this sensor.

IN-CABIN MICROFILTER

The air conditioning system is equipped with an in-cabin microfilter which collects dirt, pollen, dust, etc. To make sure air conditioner heats, defogs, and ventilates efficiently, replace the filter in accordance with the maintenance schedule in this manual. To replace

the filter, contact your INFINITI retailer.

The filter should be replaced if air flow is extremely decreased or when windows fog up easily during operating heater or air conditioning system.

SERVICING AIR CONDITIONER

The air conditioning system in your INFINITI is charged with a refrigerant designed with the environment in mind. **This refrigerant will not harm the earth's ozone layer.** However, special charging equipment and lubricant are required when servicing your INFINITI air conditioner. Using improper refrigerants or lubricants will cause severe damage to your air conditioning system. See "Capacities and recommended fuel/lubricants" in the "10. Technical and consumer information" section for air conditioning system refrigerant and lubricant recommendations.

Your INFINITI retailer will be able to service

your environmentally friendly air conditioning system.



WARNING

The air conditioner system contains refrigerant under high pressure. To avoid personal injury, any air conditioner service should be done only by an experienced technician with proper equipment.

AUDIO SYSTEM

RADIO

Turn the ignition key to ACC or ON and press the power on switch to turn on the radio. If you listen to the radio with the engine not running, the key should be turned to the ACC position.

Radio reception is affected by station signal

HEATER, AIR CONDITIONER AND AUDIO SYSTEMS

strength, distance from radio transmitter, buildings, bridges, mountains and other external influences. Intermittent changes in reception quality normally are caused by these external influences.

Using a cellular phone in or near the vehicle may influence radio reception quality.

Radio reception

Your INFINITI radio system is equipped with state-of-the-art electronic circuits to enhance radio reception. These circuits are designed to extend reception range, and to enhance the quality of that reception.

However there are some general characteristics of both FM and AM radio signals that can affect radio reception quality in a moving vehicle, even when the finest equipment is used. These characteristics are completely normal in a given reception area, and do not

indicate any malfunction in your INFINITI radio system.

Remember that a moving vehicle is not the ideal place to listen to a radio. Because of the movement, reception conditions will constantly change. Buildings, terrain, signal distance and interference from other vehicles can work against ideal reception. Described below are some of the factors that can affect your radio reception.

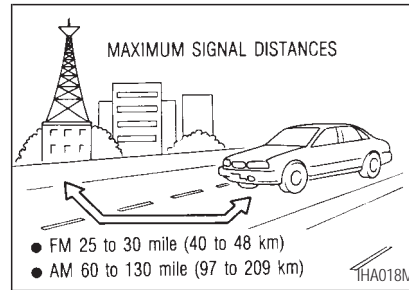

FM RADIO RECEPTION

Range: FM range is normally limited to 25 to 30 miles (40 to 48 km), with monaural (single channel) FM having slightly more range than stereo FM. External influences may sometimes interfere with FM station reception even if the FM station is within 25 miles (40 km). The strength of the FM signal is directly related to the distance between the transmitter and receiver. FM signals follow a line-of-sight path, exhibiting many of the same characteristics as light. For example they will reflect off objects.

Fade and drift: As your vehicle moves away from a station transmitter, the signals will tend to fade and/or drift.

Static and flutter: During signal interference from buildings, large hills or due to antenna position, usually in conjunction with increased distance from the station transmitter, static or flutter can be heard. This can be

HEATER, AIR CONDITIONER AND AUDIO SYSTEMS

reduced by adjusting the TREBLE control counterclockwise to reduce treble response.

Multipath reception: Because of the reflective characteristics of FM signals, direct and reflected signals reach the receiver at the same time. The signals may cancel each other, resulting in momentary flutter or loss of sound.

AM RADIO RECEPTION

AM signals, because of their low frequency, can bend around objects and skip along the ground. In addition, the signals can be bounced off the ionosphere and bent back to earth. Because of these characteristics, AM signals are also subject to interference as they travel from transmitter to receiver.

Fading: Occurs while the vehicle is passing through freeway underpasses or in areas with many tall buildings. It can also occur for several seconds during ionospheric turbulence even in areas where no obstacles exist.

Static: Caused by thunderstorms, electrical power lines, electric signs and even traffic lights.

AUDIO OPERATION PRECAUTIONS

Cassette player

- To maintain good quality sound, INFINITI recommends that you use cassette tapes of 60 minutes or shorter in length.
- Cassette tapes should be removed from the player when not in use. Store cassettes in their protective cases and away from direct sunlight, heat, dust, moisture or magnetic sources.

Direct sunlight can cause the cassette to become deformed. The use of deformed cassettes may cause the cassette to jam in the player.

- **Do not use cassettes that have peeling or loose labels. If used, the label could jam in the player.**
- If a cassette has loose tape, insert a pencil through one of the cassette hubs and rewind the tape firmly. Loose tape may cause tape jamming and wavering sound quality.
- Over a period of time, the playback head, capstan and pinch roller may gather a tape coating residue as the tape passes over the head. This residue accumulation can cause a weak or wavering sound and should be removed periodically with a head cleaning tape.

If the residue is not removed periodically, the player may need to be disassembled for cleaning.

HEATER, AIR CONDITIONER AND AUDIO SYSTEMS

Compact disc (CD) player operation



CAUTION

- *During cold weather or rainy days, the player may malfunction due to the humidity. If this occurs, remove the CD and dehumidify or ventilate the player completely.*
- *The player may skip while driving on rough roads.*
- *The CD player sometimes cannot function when the compartment temperature is extremely high. Decrease the temperature before use.*
- *Do not expose the CD to direct sunlight.*

- *CDs that are of poor quality, dirty, scratched, or covered with fingerprints, or that have pin holes may not work properly.*
- *The following CDs may not work properly.*
 - *Copy control compact discs*
 - *Recordable compact discs (CD-R)*
 - *Rewritable compact discs (CD-RW)*
- *Do not use the following CDs as they may cause the CD player to malfunction.*
 - *8 cm (3.1 in) discs with an adapter*
 - *CDs that are not round*

- *CDs with a paper label*
- *CDs that are warped, scratched, or have abnormal edges*

HEATER, AIR CONDITIONER AND AUDIO SYSTEMS

FM-AM RADIO WITH CASSETTE PLAYER

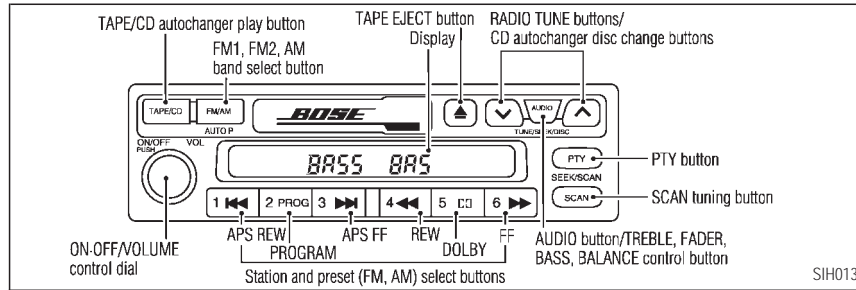

Refer to the separate Owner's Manual for information about the navigation system.

Audio main operation

ON-OFF/Volume control :

Turn the ignition key to ACC or ON, then push the ON-OFF/Volume control knob. The mode (radio or cassette) which was playing immediately before the system was turned off resumes playing. When no cassette is loaded,

the radio comes on. Pushing the ON-OFF/Volume control knob again turns the system off.

Turn the ON-OFF/Volume control knob to adjust the volume.

AUDIO button (BASS, TREBLE, FADER, BALANCE, SCV) :

Press the AUDIO button to change the selecting mode as follows:

BASS → TREBLE → FADER → BALANCE → BASS.

To adjust Bass, Treble, Fader, Balance, press the AUDIO button until the desired mode BASS, TREBLE, FADER or BALANCE appears in the display.

Press the ∇ or \blacktriangle button to adjust Bass and Treble to the desired level. Use the ∇ or \blacktriangle button to adjust Fader or Balance modes. Fader adjusts the sound level between the front and rear speakers and Balance adjusts the sound level between the right and left speakers.

After 10 seconds, the radio or cassette tape display reappears. Once the sound quality is set to the desired level, press the AUDIO

HEATER, AIR CONDITIONER AND AUDIO SYSTEMS

button repeatedly until the radio or cassette tape display appears.

Radio/Cassette tape priority mode

In this mode, the radio station illuminates in the display during radio operation. During cassette tape operation, TAPE illuminates in the display.

FM-AM radio operation

 **FM-AM band select :**

Pushing the FM-AM band select button will change the band as follows:

AM → AM (preset station) → FM1 → FM2
→ FM (preset station) → AM

When FM/AM band select button is pushed while the ignition switch is in the ACC or ON, the radio will come on at the station last played.

The last station played will also come on when

the power knob is turned to ON.

If a compact disc or tape is playing when the FM/AM band select button is turned to ON, the compact disc or tape will automatically be turned off and the last radio station played will come on.

The FM stereo indicator ST illuminates during FM stereo reception. When the stereo broadcast signal is weak, the radio automatically changes from stereo to monaural reception.



TUNE (Tuning) :



WARNING

The radio should not be tuned while driving so full attention may be given to vehicle operation.

Use these buttons for manual tuning. To move quickly through the channels, hold either of

the TUNE buttons down for more than 0.5 seconds.

SCAN tuning :

Push the SCAN tuning button and SCAN will illuminate in the display window. SCAN tuning begins from high to low or low to high frequencies and stops at each broadcasting station for 5 seconds. Pushing the button again during this 5 second period stops SCAN tuning and the radio remains tuned to that station.

If any of the SEEK/SCAN tuning buttons are not pushed within 5 seconds, SCAN tuning moves to the next station.

Station memory (and preset) operations :

Twelve stations can be set for the FM band (six for FM1, six for FM2) and six stations can be set for the AM band.

1. Tune to the desired station using the

HEATER, AIR CONDITIONER AND AUDIO SYSTEMS

SCAN or TUNE buttons.

2. Select the desired station and keep pushing any of the desired station memory buttons (1 to 6) until a beep sound is heard. (The radio mutes when the select button is pushed.)
3. The channel indicator will come on and the sound will resume. Memorizing is now complete.
4. Other station select buttons can be set in the same manner.

If the battery cable is disconnected, or if the radio fuse opens, the radio memory is cancelled. In that case, reset the desired stations.

PTY Program type :

When PTY button is pressed during FM mode, the PTY name of the current tuned station is displayed. During this time if the PTY data code is zero, or the data is unreadable; the display will show NONE.

1. PTY selection mode

PTY name selection can be done by the up/down TUNE button \wedge or \vee in the PTY selection mode.

It is possible to shift the PTY name by one step, with one push of the up/down tuning button \wedge or \vee .

PTY name selection can also be achieved by pressing the preset buttons.

Initial PTY names are stored in the preset buttons; but these can be changed by pressing the preset buttons for more than 1.5 seconds when the desired PTY name is in the display.

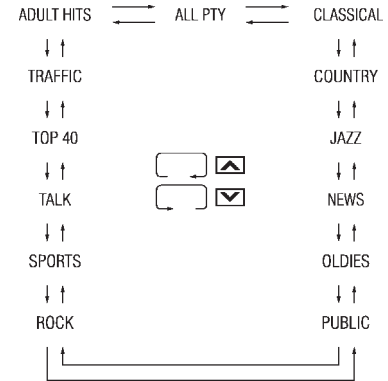

2. PTY SEEK tuning

After selecting a PTY name, push the TUNE button \vee or \wedge within 10 seconds. Tuning to the PTY station will start. If you do not push the TUNE button within the 10 second period, the PTY mode will be canceled.

HEATER, AIR CONDITIONER AND AUDIO SYSTEMS

3. PTY SCAN tuning mode

Push the SCAN tuning button to tune the PTY name station, and stop at each broadcasting station for 5 seconds. Pushing the button again during this 5 second period will stop SCAN tuning and the radio will remain tuned to that station. If the SCAN tuning button is not pushed within 5 seconds, SCAN tuning moves to the next station.

Cassette tape player operation

Turn the ignition key to ACC or ON, then carefully insert a cassette tape into the tape door.

The cassette tape automatically pulls into the player. The word TAPE and moving digital squares illuminate on the right side of the display window.



CAUTION

Do not force the cassette tape into the tape door. This could cause player damage.

The cassette tape automatically changes directions to play the other side when the first side is complete. At this time, the moving digital squares illuminate on the left side of the display window.

TAPE/CD

PLAY :

When the TAPE/CD button is pushed with the radio turned on and the tape loaded, the radio will automatically be turned off and the tape will play.

If the TAPE/CD button is pushed during either the FF, REW, APS FF or APS REW function, the cassette tape enters the normal play mode.

When the TAPE/CD button is pushed with the CD playing, the tape will play.

4 ◀◀

6 ▶▶

**FF (fast forward),
REW (rewind) :**

Push either the FF or REW button for the desired direction.

The FF or REW symbol illuminates in the display.

To stop the FF or REW function, press the FF or REW button again, or the TAPE/CD button.

1 ◀◀

3 ▶▶

**APS (automatic program search) FF, APS
REW :**

Push either the APS FF or APS REW button while the cassette tape is playing. The tape runs quickly, stops, then plays the next selection. Either the FF or REW symbol flashes in the display while searching for the selection.

This system searches at the blank intervals

HEATER, AIR CONDITIONER AND AUDIO SYSTEMS

between selections. If there is a blank interval within one selection or there is no interval between selections, the system may not stop in the desired or expected location.

PROG (program) :

Push the PROG button. The moving digital squares illuminate on either the right or left side of the display window to indicate the side of program play.

If the PROG button is pushed during either the FF or REW function the tape enters the normal play mode.

Dolby NR (Noise Reduction) :

Push the Dolby NR  button for Dolby NR encoded tapes to reduce high frequency tape noise. The  indicator light comes on.

Dolby NR is manufactured under license from Dolby Laboratories Licensing Corporation. DOLBY NR and the double-D symbol  are trademarks of Dolby Laboratories

Licensing Corporation.

Metal or chrome tape usage :

The cassette player is automatically set to high performance play when playing a metal or chrome cassette tape.

TAPE EJECT :

Push the EJECT button. The cassette tape automatically comes out.

HEATER, AIR CONDITIONER AND AUDIO SYSTEMS

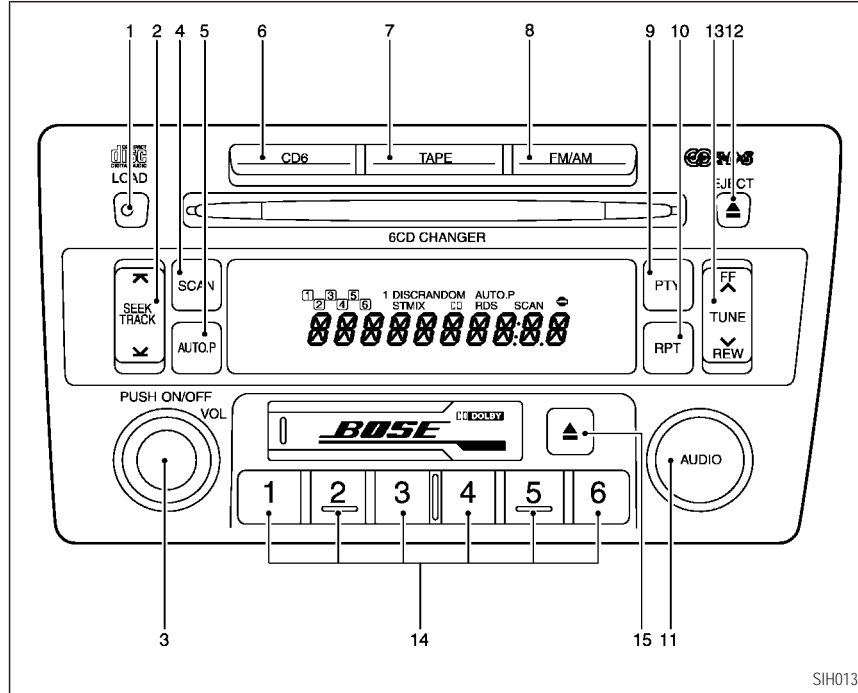

1. CD LOAD button
2. SEEK/APS REW, APS FF/TRACK CHANGE button
3. ON-OFF/VOLUME control knob
4. SCAN tuning button
5. AUTO.P (Automatic preset) button
6. CD play button
7. TAPE play button
8. FM/AM band select button
9. PTY (Program type) button
10. RPT (repeat) play button
11. AUDIO (BASS, TREBLE, FADER, BALANCE and NR (Dolby)) button
12. CD EJECT button
13. RADIO TUNE/FF-REW/AUDIO (Bass, treble, fader, balance) ADJUSTING button
14. Station and preset (FM/AM)/CD insert or CD play select button
15. TAPE EJECT button

HEATER, AIR CONDITIONER AND AUDIO SYSTEMS

FM-AM RADIO WITH CASSETTE PLAYER AND COMPACT DISC (CD) PLAYER/CHANGER

Audio main operation

Head unit

The radio has an FM diversity reception system, which employs two antennas printed on the front window. This system automatically switches to the antenna which is receiving less interference.

The tape deck employs a permalloy head which allows for improved reproduction of high frequency ranges. Noise is also greatly reduced by the combined use of the Dolby NR (Noise Reduction) system. The auto loudness circuit enhances the low frequency range automatically in both radio reception and tape and CD playback.

ON-OFF/Volume control :

Turn the ignition key to ACC or ON, and then

push the ON-OFF/VOL control knob while the system is off to call up the mode (radio, tape or CD) which was playing immediately before the system was turned off. When no CD or tape is loaded, the radio will come on. While the system is on, pushing the ON-OFF/VOL control knob turns the system off.

To turn the radio off, press the ON-OFF/VOL control knob.

Turn the ON-OFF/VOL control knob to adjust the volume.

AUDIO button (BASS, TREBLE, FADER, BALANCE and NR (Dolby)) :

Press the AUDIO button to change the select mode as follows.

BASS → TREBLE → FADER → BALANCE → NR (when cassette playing) → BASS

To adjust BASS, Treble, Fader and Balance, press the AUDIO button until the desired mode BASS, TREBLE, FADER or BALANCE

appears in the display. Press the TUNE (∨) or (∧) button to adjust Bass and Treble to the desired level. Use the ∨ or ∧ button also to adjust Fader or Balance modes. Fader adjusts the sound level between the front and rear speakers and Balance adjusts the sound between the right and left speakers.

To change the NR (Dolby) mode to OFF or ON, press the ∨ or ∧ (TUNE) button while cassette tape is playing. When Dolby is ON, the display indicates the  mark.

After 10 seconds, the radio or cassette tape display reappears. Once the sound quality is set to the desired level, press the AUDIO button repeatedly until the radio or cassette tape display appears.

Dolby noise reduction manufactured under license from Dolby Laboratories Licensing Corporation. Dolby NR and the double-D symbol  are trademarks of Dolby Labo-

ratories Licensing Corporation.

Metal or chrome tape usage :

The cassette player will be automatically set to high performance play when playing a metal or chrome cassette tape.

FM-AM radio operation

FM/AM band select :

Pushing the FM/AM band select button will change the band as follows:

AM → FM1 → FM2 → AM

When FM/AM band select button is pushed while the ignition switch is in the ACC or ON, the radio will come on at the station last played.

The last station played will also come on when the power knob is turned to ON.

If a compact disc or tape is playing when the FM/AM band select button is turned to ON, the compact disc or tape will automatically be

HEATER, AIR CONDITIONER AND AUDIO SYSTEMS

turned off and the last radio station played will come on.

The FM stereo indicator ST will glow during FM stereo reception. When the stereo broadcast signal is weak, the radio will automatically change from stereo to monaural reception.

TUNE (Tuning) :





WARNING

The radio should not be tuned while driving so full attention may be given to vehicle operation.

Use these buttons for manual tuning. To move quickly through the channels, hold either of the TUNE buttons down for more than 0.5 seconds.

SEEK tuning :

Push the SEEK button  or , to tune from high to low or low to high frequencies and stops at the next broadcasting station.

SCAN tuning :

Push the SCAN tuning button to tune from low to high frequencies and stops at each broadcasting station for 5 seconds. Pushing the button again during this 5 seconds period will stop SCAN tuning and the radio will remain tuned to that station.

If the SCAN tuning button is not pushed within 5 seconds, SCAN tuning moves to the next station.

Station memory operations :

Twelve stations can be set for the FM band (six for FM1, six for FM2) and six stations can be set for the AM band.

1. Tune to the desired station using the

HEATER, AIR CONDITIONER AND AUDIO SYSTEMS

SEEK, SCAN or TUNE button.

2. Select the desired station and keep pushing any of the desired station memory buttons (1 to 6) until a beep sound is heard. (For example, in the diagram ch2 is to be memorized. The radio mutes when the select button is pushed.)
3. The indicator ch2 will then come on and the sound will resume. Memorizing is now complete.
4. Other buttons can be set in the same manner.

If the battery cable is disconnected, or if the fuse blows, the radio memory will be cancelled. In that case, reset the desired stations.

AUTO.P (Automatic preset) button :

To select the preset FM, AM or PTY station, push the AUTO.P button for less than 1.5 seconds.



To preset the FM, AM or PTY station, push



the AUTOP button for more than 1.5 seconds.



PTY (Program type) button :

When PTY button is pressed during FM mode, the PTY name of the current tuned station is displayed. During this time if the PTY data code is zero, or the data is unreadable; the display will show NONE.

1. PTY selection mode

PTY name selection can be done by the up/down TUNE button  or  in the PTY selection mode.

After selecting a PTY name, push the TUNE button  or  within 10 seconds. Tuning to the PTY station will start. If you do not push the TUNE button within the 10 second period, the PTY mode will be canceled.

It is possible to shift the PTY name by one step, with one push of the up/down tuning button  or .

PTY name selection can also be achieved by pressing the preset buttons.

Initial PTY names are stored in the preset buttons; but these can be changed by pressing the preset buttons for more than 1.5 seconds when the desired PTY name is in the display.

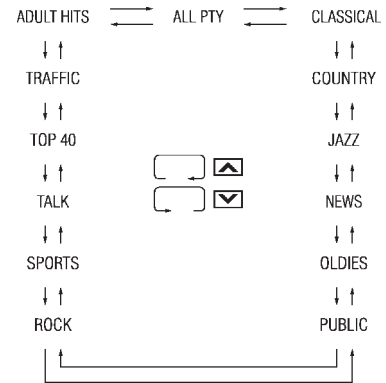

HEATER, AIR CONDITIONER AND AUDIO SYSTEMS

2. PTY SCAN tuning mode

Push the SCAN tuning button to tune the PTY name station, and stop at each broadcasting station for 5 seconds. Pushing the button again during this 5 second period will stop SCAN tuning and the radio will remain tuned to that station. If the SCAN tuning button is not pushed within 5 seconds, SCAN tuning moves to the next station.

Cassette tape player operation

Turn the ignition key to ACC or ON, and then lightly insert the cassette tape into the tape door. The cassette tape will be automatically pulled into the player.

The radio or CD will turn off (if it is on) and the cassette tape will begin to play.



CAUTION

Do not force the cassette tape into the tape door. This could cause player damage.

If the system is turned off by pushing the ON-OFF/VOL control knob with the cassette tape still in the player, the tape will resume playing when the system is turned back on.





TAPE PLAY :

- When the TAPE button is pushed with the system turned off and a tape loaded, the system will come on and the tape will play.
- When the TAPE button is pushed with either the radio or compact disc turned on and the tape loaded, the compact disc or the radio will automatically be turned off and the tape will play.

- When the TAPE button is pushed while the tape is being played, the tape side will be changed.





**FF (Fast Forward),
REW (Rewind) :**

Push the  (fast forward) button to fast forward the tape. To rewind the tape, push the  (rewind) button. Either the FF or REW symbol illuminates on the right side of the display window. To stop the FF or REW function, press the  (fast forward) or  (rewind) again, or the TAPE button.





**APS (Automatic Program Search) FF ,
APS REW :**

When the  (APS FF) button is pushed while the tape is being played, the next program will start to play from the beginning. Push the  (APS FF) button several times to skip through programs. The tape will advance the number of times the button is

HEATER, AIR CONDITIONER AND AUDIO SYSTEMS

pushed (up to nine programs).

When the  (APS REW) button is pushed once, the program being played starts over from the beginning. Push the  (APS REW) button several times to skip back several selections. The tape will go back the number of times the button is pushed. Either the FF or REW symbol flashes on the right side of the display window while searching for the selection.

This system searches for the blank intervals between selections. If there is a blank interval within one program or there is no interval between programs, the system may not stop in the desired or expected location.

SCAN tuning :

Push the SCAN tuning button while playing tape, and it stops at the next tape program for 5 seconds. Pushing the button again during this 5 second period will stop SCAN tuning and the tape program is continued. If the

SCAN tuning button is not pushed within 5 seconds, SCAN tuning moves to the next tape program.

TAPE EJECT :

When this button is pushed with the tape loaded, the tape will be ejected.

When the tape is ejected while it is being played, the system will be turned off.

Compact disc (CD) changer operation

Turn the ignition key to the ACC or ON position and insert the compact disc into the slot with the label side facing up. The compact disc will be guided automatically into the slot and start playing.

After loading the disc, the number of tracks on the disc and the play time will appear on the display.

If the radio or tape is already operating, it will

automatically turn off and the compact disc will play.



CAUTION

Do not force the compact disc into the slot. This could damage the player.

If the system has been turned off while the compact disc was playing, pushing the ON-OFF/VOL control knob will start the compact disc.

8 cm diameter compact discs can also be used without an adapter.

button :

To insert a CD in the CD changer, push the LOAD button for less than 1.5 seconds. And select the loading slot by pushing the CD insert select button (1 to 6) then insert the CD.

To insert 6 CDs to the CD changer, push the

HEATER, AIR CONDITIONER AND AUDIO SYSTEMS

LOAD button for more than 1.5 seconds.



The inserted slot numbers will illuminate on the display.

CD6 PLAY :

When the CD6 button is pushed with the system off and the compact disc loaded, the system will turn on and the compact disc will start to play.



When the CD6 button is pushed with the compact disc loaded but the tape or the radio playing, the tape or radio will automatically be turned off and the compact disc will start to play.

FF (Fast Forward), REW (Rewind) :

When the  (fast forward) or  (rewind) button is pushed while the compact disc is being played, the compact disc will play while fast forwarding or rewinding. When the button is released, the compact disc will

return to normal play speed.

APS (Automatic Program Search) FF, APS REW :

When the  (APS FF) button is pushed while the compact disc is being played, the program next to the present one will start to play from its beginning. Push several times to skip through programs. The compact disc will advance the number of times the button is pushed. (When the last program on the compact disc is skipped through, the first program will be played.) When the  (APS REW) button is pushed, the program being played returns to its beginning. Push several times to skip back through programs. The compact disc will go back the number of times the button is pushed.

CD PLAY button :

To change CD, push the CD play select button (1 to 6).

SCAN SCAN tuning :

When the SCAN tuning button is pushed for less than 1.5 seconds while the CD is being played, the beginning of all the tracks of CDs will be played for 10 seconds in sequence.

When the SCAN tuning button is pushed for more than 1.5 seconds while the CD is being played, the first program in all the CDs will be played for 10 seconds.

Pushing the button again during this 10 second period will stop SCAN tuning.

If the SCAN tuning button is not pushed within 10 seconds, SCAN tuning moves to the next disc program.

RPT REPEAT (RPT) :

When the RPT button is pushed while the compact disc is played, the play pattern can be changed as follows:



HEATER, AIR CONDITIONER AND AUDIO SYSTEMS

DISPLAY CD TEXT :

To indicate the CD mode text, push the PTY button during CD playing.

To change the indicated text, push the PTY button.

The text will change as follows:



If the text is more than 11 letters, push the AUTO.P button to display the remaining text.

CD EJECT :

When the CD EJECT button is pushed with the compact disc loaded, the compact disc will be ejected.

To eject the discs selected by the CD select button, push the EJECT button for less than 1.5 seconds.

To eject all the discs, push the EJECT button

for more than 1.5 seconds.

If the compact disc comes out and is not removed, it will be pulled back into the slot to protect it. (without 8 cm diameter compact discs)

CD IN indicator :

CD IN indicator appears on the display when the CD is loaded with the system on.

CD CARE AND CLEANING

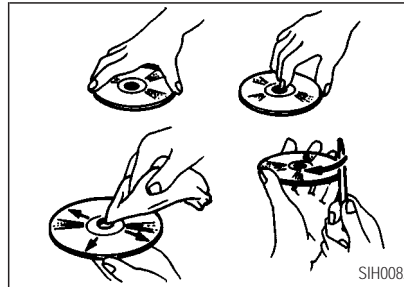

- Handle a CD by its edges. Never touch the

surface of the disc. Do not bend the disc.

- Always place the discs in the storage case when they are not being used.
- To clean a disc, wipe the surface from the center to the outer edge using a clean, soft cloth. Do not wipe the disc using a circular motion. Do not use a conventional record cleaner or alcohol intended for industrial use.
- A new disc may be rough on its inner and outer edges. Remove the rough edges using the side of a pen or pencil as illustrated.

HEATER, AIR CONDITIONER AND AUDIO SYSTEMS

STEERING WHEEL SWITCH FOR AUDIO CONTROL (if so equipped)

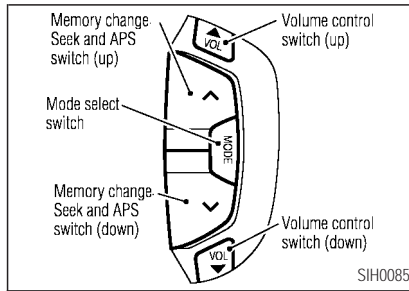

The audio system can be operated using the controls on the steering wheel.

MODE select switch

Push the mode select switch to change the mode in the sequence of AM, FM1, FM2, CD, (if so equipped) CD autochanger and Tape.

Volume control switches

Push the upper side switch or lower side switch to adjust the volume.



Upper side: Volume increases

Lower side: Volume decreases





Tuning

Memory change (radio) :

Push the tuning switch  or  for less than 1.5 seconds to change the radio frequency.

SEEK tuning (radio) :

Push the tuning switch  or  for more than 1.5 seconds to seek the next or previous radio station.

APS (Automatic Program Search) FF, APS REW (tape/CD) :

Push the tuning switch  for less than 1.5 seconds while the tape/CD is being played,

the next program will start to play from the beginning.

Push the  switch several times to skip through programs. The tape/CD will advance the number of times the switch is pushed (up to nine programs).



Push the tuning switch  for less than 1.5 seconds and, the program being played starts over from the beginning.



Push the  switch several times to skip back several selections. The tape/CD will go back the number of times the switch is pushed. Either the FF or REW symbol flashes on the right side of the display window while searching for the selection.

This system searches for the blank intervals between selections. If there is a blank interval within one program or there is no interval between programs, the system may not stop in the desired or expected location.

HEATER, AIR CONDITIONER AND AUDIO SYSTEMS

FF (Fast Forward), REW (Rewind) (tape) :

Push the tuning button  for more than 1.5 seconds to fast forward the tape. To rewind the tape, push the tuning button  for more than 1.5 seconds. Either the FF or REW symbol illuminates on the right side of the display window.

To stop the FF or REW function, press the  or  button again for more than 1.5 seconds.

ANTENNA

Power antenna

The antenna will automatically extend when the radio is turned on, and retract when switched off. If the radio is left on, the antenna will retract and extend with the ignition key OFF-ON operation.



CAUTION

- *Before turning the radio on, make sure that no one is near the antenna outlet and there is enough space for it to extend.*
- *To prevent damage, be sure that power antenna is fully retracted before the vehicle enters an automatic car wash.*
- *Dirt and other foreign matter on the power antenna rod may interrupt its operation. Clean the rod periodically with a damp cloth. This type of cleaning is especially important during the winter seasons in areas where road salt and other chemicals may be spread on road surfaces and splashed*

onto the antenna rod.

Window antenna

The antenna pattern is printed inside the windshield.



CAUTION

- *Do not place metalized film near the windshield glass or attach any metal parts to it. This may cause poor reception or noise.*
- *When cleaning the inside of the windshield, be careful not to scratch or damage the windshield window antenna. Lightly wipe along the antenna with a dampened soft cloth.*

HEATER, AIR CONDITIONER AND AUDIO SYSTEMS

CAR PHONE OR CB RADIO

When installing a car phone or a CB radio in your INFINITI, be sure to observe the following cautions, otherwise the new equipment may adversely affect the Engine Control system and other electronic parts.



WARNING

- *A cellular telephone should not be used while driving so full attention may be given to vehicle operation. Some jurisdictions prohibit the use of cellular telephones while driving.*
- *If you must make a call while your vehicle is in motion, the hands free cellular phone operational mode (if so equipped) is highly recommended. Exercise extreme caution at all times so full atten-*

tion may be given to vehicle operation.

- *If a conversation in a moving vehicle requires you to take notes, pull off the road to a safe location and stop your vehicle before doing so.*



CAUTION

- *Keep the antenna as far as possible away from the Engine Control Module (ECM).*
- *Keep the antenna wire more than 8 in (20 cm) away from the PCME harness. Do not route the antenna wire next to any harness.*
- *Adjust the antenna standing-wave ratio as recommended by the*

manufacturer.

- *Connect the ground wire from the CB radio chassis to the body.*
- *For details, consult an authorized INFINITI retailer.*

5 STARTING AND DRIVING

Precautions when starting and driving	5-2	Intelligent cruise control system (if so equipped)	5-19
Exhaust gas (Carbon monoxide).....	5-2	Driving with intelligent cruise control system	5-21
Three way catalyst	5-3	Intelligent cruise control switch.....	5-25
On-pavement and offroad driving precautions.....	5-4	Intelligent cruise control system display	5-25
Avoiding collision and rollover.....	5-4	Operating intelligent cruise control system	5-26
Drinking alcohol/drugs and driving.....	5-5	How to change the set vehicle speed.....	5-29
Driving safety precautions.....	5-5	How to change the set distance to the ve- hicle ahead	5-29
Ignition switch	5-8	Approach warning	5-31
Key positions.....	5-9	Automatic cancellation.....	5-32
Infiniti Vehicle Immobilizer System	5-9	Warning indicator.....	5-32
Before starting the engine.....	5-9	How to handle the sensor.....	5-33
Starting the engine.....	5-10	Break-in schedule	5-34
Driving the vehicle.....	5-11	Increasing fuel economy	5-34
Automatic transmission	5-11		
Parking brake.....	5-16		
Cruise control	5-17		
Precautions on cruise control	5-17		
Cruise control operations.....	5-17		

Using four wheel drive (4WD)	5-35	Anti-freeze	5-47
Transfer case shifting procedures.....	5-35	Battery	5-47
Parking/parking on hills.....	5-43	Draining of coolant water	5-47
Power steering.....	5-44	Tire equipment	5-48
Brake system	5-45	Special winter equipment.....	5-49
Anti-lock brake system (ABS)	5-45	Driving on snow or ice	5-49
Cold weather driving	5-47	Engine block heater (if so equipped)...	5-50
Freeing a frozen door lock	5-47		

STARTING AND DRIVING

PRECAUTIONS WHEN STARTING AND DRIVING



WARNING

- *Do not leave children or adults who would normally require the support of others alone in your vehicle. Pets should not be left alone either. They could accidentally injure themselves or others through inadvertent operation of the vehicle. Also, on hot, sunny days, temperatures in a closed vehicle could quickly become high enough to cause severe or possibly fatal injuries to people or animals.*
- *Properly secure all cargo to help prevent it from sliding or shifting. Do not place cargo higher than the seatbacks. In a sudden stop or collision, unsecured cargo could cause personal injury.*

EXHAUST GAS (Carbon monoxide)



WARNING

Do not breathe exhaust gases. They contain colorless and odorless carbon monoxide. Carbon monoxide is dangerous. It can cause unconsciousness or death.

- *If you suspect that exhaust fumes are entering the vehicle, drive with all windows fully open, and have the vehicle inspected immediately.*
- *Do not run the engine in closed spaces such as a garage.*
- *Do not park the vehicle with the engine running for any extended length of time.*

- *Keep the back door and glass hatch closed while driving, otherwise exhaust gases could be drawn into the passenger compartment. If you must drive with the back door or glass hatch open follow these precautions:*
 1. *Open all the windows.*
 2. *Set the air recirculation switch OFF and the fan control at high to circulate the air.*
- *If electrical wiring or other cable connections must pass to a trailer through the seal on the trunk lid or the body, follow the manufacturer's recommendation to prevent carbon monoxide entry into the vehicle.*

- *If a special body on other equipment is added for recreational or other usage, follow the manufacturer's recommendation to prevent carbon monoxide entry into the vehicle. (Some recreational vehicle appliances such as stoves, refrigerator, heaters, etc. may also generate carbon monoxide.)*
- *The exhaust system and body should be inspected by a qualified mechanic whenever:*
 - a. The vehicle is raised for service.*
 - b. You suspect that exhaust fumes are entering into the passenger compartment.*
 - c. You notice a change in the sound of the exhaust system.*

- d. You have had an accident involving damage to the exhaust system, underbody, or rear of the vehicle.*

THREE WAY CATALYST

The three way catalyst is an emission control device installed in the exhaust system. Exhaust gases in the three way catalyst are burned at high temperatures to help reduce pollutants.



WARNING

- *The exhaust gas and the exhaust system are very hot. Keep people, animals or flammable materials away from the exhaust system components.*

STARTING AND DRIVING

- *Do not stop or park the vehicle over flammable materials such as dry grass, waste paper or rags. They may ignite and cause a fire.*



CAUTION

- *Do not use leaded gasoline. Deposits from leaded gasoline seriously reduce the three way catalyst ability to reduce exhaust pollutants.*
- *Keep your engine tuned up. Malfunctions in the ignition, fuel injection, or electrical systems can cause overrich fuel flow into the three way catalyst, causing it to overheat. Do not keep driving if the engine misfires, or if notice-*

STARTING AND DRIVING

able loss of performance or other unusual operating conditions are detected. Have the vehicle inspected promptly by an authorized INFINITI retailer.

- *Avoid driving with an extremely low fuel level. Running out of fuel could cause the engine to misfire, damaging the three way catalyst.*
- *Do not race the engine while warming it up.*
- *Do not push or tow your vehicle to start the engine.*

ON-PAVEMENT AND OFFROAD DRIVING PRECAUTIONS

Utility vehicles have a significantly higher rollover rate than other types of vehicles.

They have higher ground clearance than passenger cars to make them capable of performing in a variety of on-pavement and offroad applications. This gives them a higher center of gravity than ordinary cars. An advantage of higher ground clearance is a better view of the road, allowing you to anticipate problems. However, they are not designed for cornering at the same speeds as conventional two-wheel drive vehicles any more than low-slung sports cars are designed to perform satisfactorily under offroad conditions. If at all possible, avoid sharp turns or abrupt maneuvers particularly at high speeds. As with other vehicles of this type, failure to operate this vehicle correctly may result in loss of control or vehicle rollover.

AVOIDING COLLISION AND ROLLOVER



WARNING

Failure to operate this vehicle in a safe and prudent manner may result in loss of control or an accident.

Be alert and drive defensively at all times. Obey all traffic regulations. Avoid excessive speed, high speed cornering, or sudden steering maneuvers, because these driving practices could cause you to lose control of your vehicle. **As with any vehicle, a loss of control could result in a collision with other vehicles or objects, or cause the vehicle to rollover, particularly if the loss of control causes the vehicle to slide sideways.** Be attentive at all times, and avoid driving when tired. Never drive when under the influence of alcohol or drugs

(including prescription or over-the-counter drugs which may cause drowsiness). Always wear your seat belt as outlined in the “1. Seats, restraints and supplemental air bag systems” section of this manual, and also instruct your passengers to do so.

Seat belts help reduce the risk of injury in collisions and rollovers. **In a rollover crash, an unbelted person is significantly more likely to die than a person wearing a seat belt.**

DRINKING ALCOHOL/ DRUGS AND DRIVING



WARNING

Never drive under the influence of alcohol or drugs. Alcohol in the bloodstream reduces coordination, delays reaction time and impairs judge-

ment. Driving after drinking alcohol increases the likelihood of being involved in an accident injuring yourself and others. Additionally, if you are injured in the accident alcohol can increase the severity of the injury.

INFINITI is committed to safe driving. But, you must choose not to drive under the influence of alcohol. Every year thousands of people are injured or killed in alcohol related accidents. Although the local laws vary on what is considered to be legally intoxicated, the fact is that alcohol affects all people differently and most people underestimate the effects of alcohol.

Remember, drinking and driving don't mix!

And that's true for drugs too (over the counter, prescription, and illegal drugs). Do not drive if your ability to operate your vehicle is impaired

STARTING AND DRIVING

by alcohol, drugs, or some other physical condition.

DRIVING SAFETY PRECAUTIONS

Your INFINITI is designed for both normal and offroad use. However, avoid driving in deep water or mud as your INFINITI is mainly designed for leisure use, unlike a conventional offroad vehicle.



WARNING

- ***Drive carefully when off the road and avoid dangerous areas. Every person who drives or rides in this vehicle should be seated with their seat belt fastened. Keep you and your passengers in position when driving over rough terrain.***

STARTING AND DRIVING

- *Before driving up or down grades, check the road surface for bumps or potholes. Be sure to climb a gentle slope and descend a gentle slope.*
- *Do not drive across steep slopes. Instead drive either straight up or straight down the slopes. Off-road vehicles can tip over sideways much more easily than they can forward or backward.*
- *Many hills are too steep for any vehicle. If you drive up them, you may stall. If you drive down them, you may not be able to control your speed. If you drive across them, you may roll over.*
- *Do not shift gears while driving on downhill grades as this could cause loss of control of the ve-*

hicle.

- *Be sure to use the engine brake. The foot brake performance may be reduced, resulting in a possible accident.*
- *Stay alert when driving to the top of a hill. At the top there could be a drop-off or other hazard that could cause an accident.*
- *If your engine stalls or you cannot make it to the top of a steep hill, never attempt to turn around. Your vehicle could tip or roll over. Always back straight down in R (Reverse) gear. Never back down in N (Neutral), using only the brake, as this could cause loss of control.*
- *Heavy braking going down a hill*

could cause your brakes to overheat and fade, resulting in loss of control and an accident. Apply brakes lightly and use a low gear to control your speed.

- *Unsecured cargo can be thrown around when driving over rough terrain. Properly secure all cargo so it will not be thrown forward and cause injury to you or your passengers.*
- *To avoid raising the center of gravity excessively, do not exceed the rated capacity of the roof rack and evenly distribute the load. Secure heavy loads in the cargo area as for forward and as low as possible. Do not equip the vehicle with tires larger than specified in this manual. This*

STARTING AND DRIVING

could cause your vehicle to roll over.

- *Do not grip the inside or spokes of the steering wheel when driving offroad. The steering wheel could move suddenly and injure your hands. Instead drive with your fingers and thumbs on the outside of the rim.*
- *Before operating the vehicle, ensure that the driver and all passengers have their seat belts fastened.*
- *Always drive with the floor mats in place as the floor may become hot.*
- *Lower your speed when encountering strong crosswinds. With a higher center of gravity, your*

INFINITI is more affected by strong side winds. Slower speeds ensure better vehicle control.

- *Do not drive beyond the performance of the tires, even with 4WD engaged. Accelerating quickly, sharp steering maneuvers or sudden braking may cause loss of control.*
- *If at all possible, avoid sharp turning maneuvers, particularly at high speeds. Your INFINITI four-wheel drive vehicle has a higher center of gravity than a two-wheel drive vehicle. The vehicle is not designed for cornering at the same speeds as conventional two-wheel drive vehicles. Failure to operate this vehicle correctly could result in*

loss of control and/or a roll over accident.

- *Always use tires of the same type, size, brand, construction (bias, bias-belted or radial), and tread pattern on all four wheels. Install tire chains on the rear wheels when driving on slippery roads and drive carefully.*
- *Be sure to check the brakes immediately after driving in mud or water. See “Brake system” later in this section for “wet brakes”.*
- *Avoid parking your vehicle on steep hills. If you get out of the vehicle and it rolls forward, backward or sideways, you could be injured.*
- *Whenever you drive off-road*

STARTING AND DRIVING

through sand, mud or water as deep as the wheel hub, more frequent maintenance may be required. See "Periodic maintenance" in the "9. Maintenance" section of this manual.

IGNITION SWITCH

The switch includes an anti-theft steering lock device.

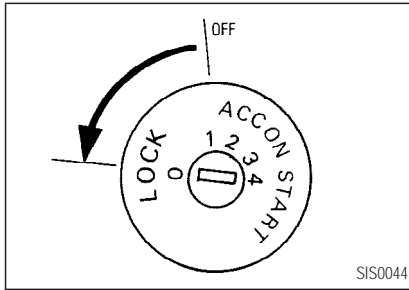

The ignition lock is designed so that the key cannot be turned to LOCK and removed until the selector lever is moved to the P (Park) position.

When removing the key from the ignition, make sure the selector lever is in the P position.

If the selector lever is not returned to P (Park), the key cannot be moved toward LOCK.

When the key cannot be turned toward the LOCK position, proceed as follows to remove the key:

- 1) Move the selector lever into the P position.
- 2) Turn the ignition key slightly in the ON direction.
- 3) Turn the key toward the LOCK position.
- 4) Remove the key.

If the key is removed from the ignition switch, the selector lever cannot be moved from P

(Park). **The selector lever can be moved if the ignition switch is in the ON position and the foot brake pedal is depressed.**

There is an OFF position in between LOCK and ACC, although it does not show on the lock cylinder. When the ignition is in OFF the steering wheel is not locked.

In order for the steering wheel to be locked, it must be turned about 1/6 of a turn clockwise from the straight up position.

To lock the steering wheel, turn the key to the LOCK position. Remove the key. To unlock the steering wheel, insert the key and turn it gently while rotating the steering wheel slightly right and left.



WARNING

Never remove or turn the key to the

LOCK position while driving. The steering wheel will lock. This may cause the driver to lose control of the vehicle and could result in serious vehicle damage or personal injury.

KEY POSITIONS

LOCK (Normal parking position) (0)

The ignition key can only be removed when the switch is in this position.

OFF (1)

The engine can be turned off without locking the steering wheel.

ACC (Accessories) (2)

This position activates electrical accessories such as the radio when the engine is not running. The automatic transmission selector lever can be shifted.

ON (Normal operating position) (3)

This position turns on the ignition system and the electrical accessories.

START (4)

This position activates the starter motor, starting the engine.

INFINITI VEHICLE IMMOBILIZER SYSTEM

The Infiniti Vehicle Immobilizer System will not allow the engine to start without the use of the registered Infiniti Vehicle Immobilizer System key.

If the engine fails to start using the registered Infiniti Vehicle Immobilizer System key (for example, when interference is caused by another Infiniti Vehicle Immobilizer System key, an automated toll road device or automated payment device on the key ring), restart the engine using the following procedures:

1. Leave the ignition switch in the ON posi-

STARTING AND DRIVING

tion for approximately 5 seconds.

2. Turn the ignition switch to the OFF or LOCK position, and wait approximately 5 seconds.
3. Repeat step 1 and 2.
4. Restart the engine while holding the device (which may have caused the interference) separate from the registered Infiniti Vehicle Immobilizer System key.

If the no start condition re-occurs, INFINITI recommends placing the registered Infiniti Vehicle Immobilizer System key on a separate key ring to avoid interference from other devices.

BEFORE STARTING THE ENGINE

- Make sure the area around the vehicle is clear.
- Check fluid levels such as engine oil, coolant, brake and clutch fluid, window

STARTING AND DRIVING

washer fluid as frequently as possible, at least whenever you refuel.

- Check to be sure that all windows and light lenses are clean.
- Visually inspect tires for condition. Also check tire pressure.
- Lock all doors.
- Position seat and adjust head restraints.
- Adjust inside and outside mirrors.
- Fasten seat belts and ask all passengers to do likewise.
- Check the operation of warning lights when key is turned to the ON (3) position.

STARTING THE ENGINE

1. Apply the parking brake.
2. Move the automatic transmission select lever to P (Park) or N (Neutral). (P preferred.)

NOTE:

The selector lever cannot be moved out of P and into any of the other gear positions if the ignition key is turned to LOCK or if the key is removed from the switch.

The starter is designed not to operate if the selector lever is in one of the driving positions.

3. Crank the engine **with your foot off the accelerator pedal** by turning the ignition key to START. Release the key when the engine starts. If the engine starts, but fails to run, repeat the above procedure.
 - When the engine is very hard to start in extremely cold weather or when restarting, depress the accelerator pedal a little (approximately 1/5 to the floor) and hold it, then crank the engine. Release the key and the ac-

celerator pedal when the engine starts.

- When the engine is very hard to start because it is flooded, depress the accelerator pedal all the way to the floor and hold it. Crank the engine for 5 to 6 seconds. After cranking the engine, release the accelerator pedal. Crank the engine **with your foot off the accelerator pedal** by turning the ignition key to START. Release the key when the engine starts. If the engine starts, but fails to run, repeat the above procedure.



CAUTION

Do not operate the starter for more than 15 seconds at a time. If the engine does not start, turn the key off

and wait 10 seconds before cranking again, otherwise the starter could be damaged.

4. Warm-up

Allow the engine to idle for at least 30 seconds after starting. Drive at moderate speed for a short distance first, especially in cold weather.

DRIVING THE VEHICLE AUTOMATIC TRANSMISSION

The automatic transmission in your vehicle is electronically controlled by a transmission control module to produce maximum power and smooth operation.

Recommended operating procedures for this transmission are shown on the following pages. Follow these procedures for maximum vehicle performance and driving enjoyment.

See "Using four wheel drive" later in this section.

Starting the vehicle

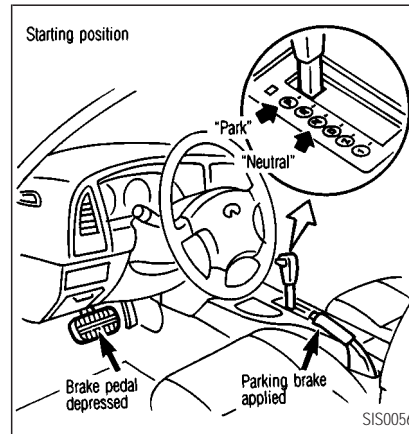

- After starting the engine, fully depress the foot brake pedal and push the selector lever button before shifting the selector lever from P to the R, N, D, 2 or 1 position. Be

STARTING AND DRIVING

sure the vehicle is fully stopped before attempting to shift the selector lever from or to P or R.

This automatic transmission is designed so that the foot brake pedal **MUST** be depressed before shifting from P (Park) to any drive position while the ignition switch is ON.

NOTE:

The selector lever cannot be moved out of P (Park) and into any of the other gear positions if the ignition key is turned to the LOCK position or if the key is removed from the switch.

1. Keep the foot brake pedal depressed and push the selector lever button to shift into a driving gear.
2. Release the parking brake and foot brake, then gradually start the vehicle in motion.

STARTING AND DRIVING

WARNING

- Do not depress the accelerator pedal while shifting from P or N to R, D, 2 or 1. Always depress the brake pedal until shifting is completed. Failure to do so could cause you to lose control and have an accident.
- Cold engine idle speed is high, so use caution when shifting into a forward or reverse gear before the engine has warmed up.
- Never shift to P or R while vehicle is moving forward. Never shift to P or D while vehicle is moving rearward. This could cause an accident.
- On slippery roads, do not down-

shift. This may cause a loss of control.

- If the selector lever cannot be moved from the P (Park) position while the engine is running and the brake pedal depressed, the stop lights may not work. Malfunctioning stop lights could cause an accident, injuring yourself and others.

CAUTION

When stopping the vehicle on an uphill grade, do not hold the vehicle by depressing the accelerator pedal. The foot brakes should be used for this purpose.

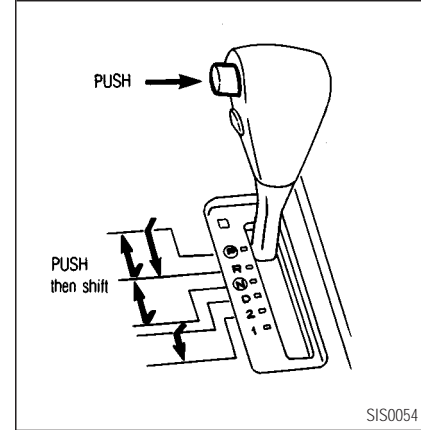

Shifting

Push the button to shift into P, or from N to R, P to R and D to 2. All other positions can be selected without pushing the button.

STARTING AND DRIVING

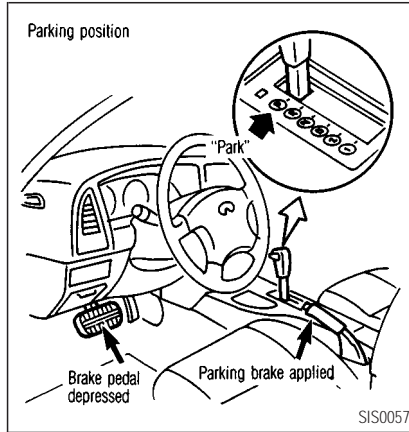

P (Park):

Use this selector position when the vehicle is parked or when starting the engine. Make sure the vehicle is completely stopped. The brake pedal must be depressed to move the selector lever from N or any drive position to P. Apply the parking brake. When parking on a hill, ap-

ply the parking brake first, then shift the lever into the P position.

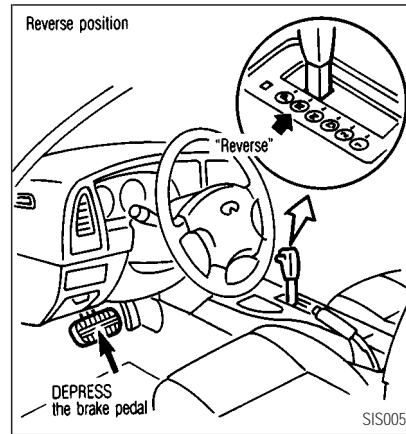

R (Reverse):

Use this position to back up. Always be sure the vehicle is completely stopped when selecting R. The brake pedal must be depressed

to move the selector lever from P, N or any drive position to R.

N (Neutral):

Neither forward or reverse gear is engaged. The engine can be started in this position. You may shift to N and restart a stalled engine while the vehicle is moving.

D (Drive):

Use this position for all normal forward driving.

2 (Second gear):

Use for hill climbing or engine braking on downhill grades or starting on slippery roads.

Push in the selector lever button and move the selector lever from the D to 2 position.

Do not downshift into the 2 position at speeds over the following speeds and do not exceed the following speeds in the 2 position:

STARTING AND DRIVING

2WD and AUTO:
60 MPH (95 km/h)
4H:
50 MPH (80 km/h)
4LO:
22 MPH (35 km/h)

1 (Low gear):

Use this position when climbing steep hills slowly or driving slowly through deep snow, sand or mud, or for maximum engine braking on steep downhill grades.

Do not downshift into the 1 position at speeds over the following speed and do not exceed the following speeds in the 1 position:

2WD and AUTO:
30 MPH (50 km/h)
4H:
30 MPH (50 km/h)
4LO:
10 MPH (15 km/h)

Shift lock release

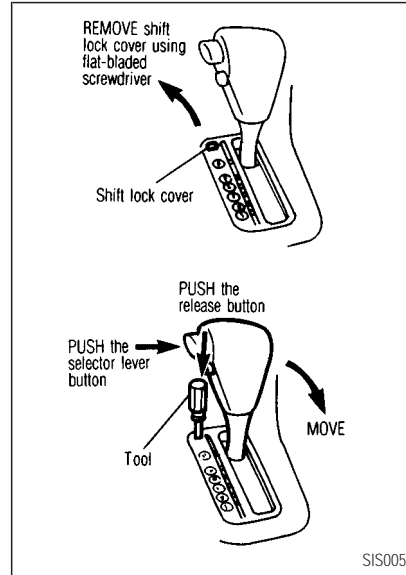

If the battery charge is low, the select lever may not be moved from the P position even with the brake pedal depressed and the select lever button pushed.

To move the select lever, push the shift lock release button and select lever button with the parking brake securely applied and the brake pedal firmly depressed. The select lever can be moved to N (Neutral).

To push the shift lock release button, follow the procedure as illustrated.

If the lever cannot be moved out of P (Park), have your INFINITI retailer check the automatic transmission system as soon as possible.



WARNING

If the selector lever cannot be moved from the P position while the engine

is running and the brake pedal is depressed, the stop lights may not work. Malfunctioning stoplights could cause an accident injuring yourself and others.

Accelerator downshift — In D position —

For passing or hill climbing, fully depress the accelerator pedal to the floor. This shifts the transmission down into second gear or first gear, depending on the vehicle speed.

Overdrive switch

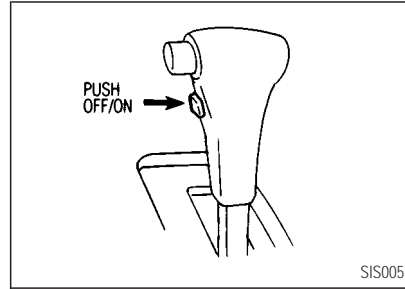

Each time your vehicle is started, the transmission is automatically reset to overdrive on.

ON: For normal driving the Overdrive switch is engaged. The transmission is upshifted into Overdrive as the vehicle speed increases.

The overdrive does not engage until the engine has warmed up.

OFF: For driving up and down long slopes where engine braking would be ad-

STARTING AND DRIVING

vantageous, push the overdrive switch. The O/D OFF light illuminates. When cruising at a low speed or climbing a gentle slope, you may feel uncomfortable shift shocks as the transmission shifts between 3rd and overdrive repeatedly. In this case, press the overdrive switch. The O/D OFF indicator light comes on at this time.

When driving conditions change, press the overdrive switch again. The O/D OFF indicator light goes out.

Remember not to drive at high speeds for extended periods of time with the O/D OFF light illuminated. This reduces the fuel economy.

Fail-safe

When the Fail-safe operation occurs, the next time the key is turned to the ON position, the O/D OFF light will blink for approximately 8

STARTING AND DRIVING

seconds after coming on for 2 seconds. While the vehicle can be driven under these circumstances please note that the gears in the automatic transmission may be locked in third gear.

If the vehicle is driven under extreme conditions, such as excessive wheel spinning and subsequent hard braking, the Fail-safe system may be activated. This will occur even if all electrical circuits are functioning properly. In this case, turn the ignition key OFF and wait for 3 seconds. Then turn the key back to the ON position. The vehicle should return to its normal operating condition. If it does not return to its normal operating condition have your INFINITI retailer check the transmission and repair if necessary.

PARKING BRAKE

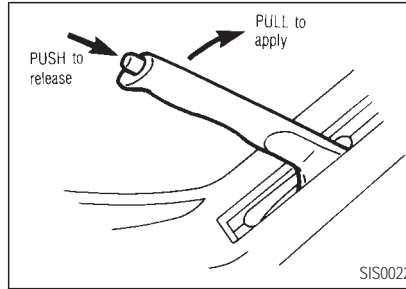

To apply: pull the lever up.

To release:

1. Firmly apply the foot brake.
2. Move the selector lever to the P position.
3. While pulling up on the lever slightly, push the button and lower completely.
4. Before driving, be sure the brake warning light goes out.



WARNING

- *Be sure the parking brake is fully released before driving. Failure to do so can cause brake failure and lead to an accident.*
- *Do not release the parking brake from outside the vehicle.*
- *Do not use the gear shift in place of the parking brake. When parking, be sure the parking brake is fully engaged.*
- *Do not leave children unattended in a vehicle. They could release the parking brake and cause an accident.*

CRUISE CONTROL

PRECAUTIONS ON CRUISE CONTROL

- If the SET control system malfunctions, it cancels automatically. The SET indicator light in the instrument panel then blinks to warn the driver.
- If the SET indicator light blinks, turn the cruise control main switch off and have the system checked by your INFINITI retailer.
- The SET indicator light may blink when the cruise control main switch is turned on while pushing the RES/ACCEL, COAST/SET, or CANCEL switch (located on the steering wheel). To properly set the cruise control system, perform the preceding steps in the order indicated.

WARNING

Do not use the cruise control when driving under the following conditions:

- ***it is not possible to keep the vehicle at a set speed.***
- ***in heavy traffic or in traffic that varies in speed.***
- ***on winding or hilly roads.***
- ***on slippery roads (rain, snow, ice, etc.)***
- ***in very windy areas.***

Doing so could cause a loss of vehicle control and result in an accident.

STARTING AND DRIVING

CRUISE CONTROL OPERATIONS

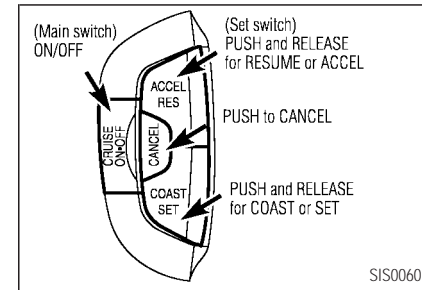

The cruise control allows driving at a speed between 25 to 89 MPH (40 to 144 km/h) without keeping your foot on the accelerator pedal.

To turn on the cruise control, push the main switch on. The cruise indicator light on the meter panel will come on.

To set at cruising speed, accelerate your vehicle to the desired speed, push the

STARTING AND DRIVING

COAST/SET switch and release it. (The SET indicator light will come on.) Take your foot off the accelerator pedal. Your vehicle will maintain the set speed.

- **To pass another vehicle**, depress the accelerator pedal. When you release the pedal, the vehicle will return to the previously set speed.
- The vehicle may not maintain the set speed when going up or down steep hills. If this happens, drive without the cruise control.

To cancel the preset speed, follow any of these methods:

- a) Push the CANCEL switch; The SET indicator light will go out.
- b) Tap the brake pedal; The SET indicator light will go out.
- c) Turn the main switch off. Both the CRUISE indicator and SET indicator lights will go out.

- If you depress the brake pedal while pushing the RES/ACCEL set switch and reset at the cruising speed, turn the main switch off once and then turn it on again.
- The cruise control will automatically be cancelled if the vehicle slows down below approximately 8 MPH (13 km/h).
- Move the selector lever to N (Neutral) position. The SET light will go out.

To reset at a faster cruising speed, use one of the following three methods:

- a) Depress the accelerator pedal. When the vehicle attains the desired speed, push and release the COAST/SET switch.
- b) Push and hold the RES/ACCEL set switch. When the vehicle attains the speed you desire, release the switch.
- c) Push, then quickly release the RES/ACCEL set switch. Each time you do this, the set

speed will increase by about 1 MPH (1.6 km/h).

To reset at a slower cruising speed, use one of the following three methods:

- a) Lightly tap the brake pedal. When the vehicle attains the desired speed, push the COAST/SET switch and release it.
- b) Push and hold the COAST/SET switch. Release the switch when the vehicle slows down to the desired speed.
- c) Push, then quickly release the COAST/SET switch. Each time you do this, the set speed will decrease by about 1 MPH (1.6 km/h).

To resume the preset speed, push and release the RES/ACCEL set switch. The vehicle will resume the last set cruising speed when the vehicle speed is over 25 MPH (40 km/h).

INTELLIGENT CRUISE CONTROL SYSTEM (if so equipped)

The Intelligent Cruise Control (ICC) system automatically maintains a selected distance from the vehicle in front of you according to that vehicle's speed, or at the set speed, if the road ahead is clear.

With ICC, the driver can maintain the same speed as other vehicles without the constant need to adjust the speed as you would with a normal cruise control system.

The system is intended to enhance the operation of the vehicle when following another vehicle traveling in the same lane and direction. If the distance sensor detects a slower moving vehicle ahead of you, the system will reduce your speed so that you follow the vehicle in front of you at the selected distance. The system automatically controls the throttle and applies the brakes (up to 25% of vehicle

braking power) if necessary.

The detection range of the sensor is about approximately 390 ft (120 m) ahead.



WARNING

- ***This system is only an aid to assist the driver and is not a collision warning or avoidance device. It is the driver's responsibility to stay alert, drive safely and be in control of the vehicle at all times.***
- ***The system is primarily intended for use on straight, dry, open roads with light traffic. It is not advisable to use the system in city traffic or congested areas.***
- ***This system will not adapt automatically to road conditions. This system should be used in evenly***

STARTING AND DRIVING

flowing traffic. Do not use the system on roads with sharp curves, or on icy roads, in heavy rain or in fog.

The distance sensor will not detect:

- Stationary and slow moving vehicles
- Pedestrians or objects in the roadway
- Oncoming vehicles in the same lane
- Motorcycles or scooters traveling offset in the travel lane

This system will not automatically brake the vehicle to a stop.

The system will cancel and a warning buzzer will sound if the speed falls below approximately 20 MPH (32 km/h). Also, the system will be disengaged below the 20 MPH (32 km/h) cut-off speed or over the maximum set speed.

STARTING AND DRIVING

The following items are controlled when the selector lever is in the D (Drive) position.

- When there are no vehicles ahead, the vehicle with this system maintains the speed set by the driver. The driver can set the speed between approximately 25 and 90 MPH (40 and 144 km/h).
- When there is a vehicle ahead, the ICC system changes vehicle speed between approximately 20 MPH (32 km/h) and the set speed to match the speed of the vehicle ahead and maintain the driver selected distance between vehicles.
- When the vehicle ahead disappears, the vehicle with this system accelerates up to and maintains the set speed.



WARNING

- *As there is a performance limit to*

the distance control function, never rely solely on the Intelligent Cruise Control system. This system does not correct careless, inattentive or absent-minded driving, or overcome poor visibility in rain, fog, or other bad weather. Decelerate the vehicle speed by depressing the brake pedal, depending on the distance to the vehicle ahead and the surrounding circumstances in order to maintain a safe distance between vehicles.

- *Although the brake operation is controlled by the system, the system does not automatically stop the vehicle. If the vehicle speed falls below approximately 20 MPH (32 km/h), the Intelligent Cruise Control system is auto-*

matically canceled and a warning buzzer sounds. (The brake control is also canceled.)

- *The system may not detect the vehicle in front of you in certain road or weather conditions. To avoid accidents, never use the Intelligent Cruise Control system under the following conditions:*
 - *On roads where the traffic is heavy or there are sharp curves*
 - *On slippery road surfaces such as on ice or snow, etc.*
 - *During bad weather (rain, fog, snow, etc.) (When the windshield wiper is operated at the low speed (LO) or high speed (HI) posi-*

tions, the Intelligent Cruise Control system is automatically canceled.)

- When strong light (for example, at sunrise or sunset) is directly shining on the front of the vehicle.
- When rain, snow or dirt adhere to the system sensor.
- On steep downhill roads (the vehicle may go beyond the set vehicle speed and frequent braking may result in overheating the brakes).
- On repeated uphill and downhill roads.
- When traffic conditions make it difficult to keep a proper

distance between vehicles because of frequent acceleration or deceleration.

DRIVING WITH INTELLIGENT CRUISE CONTROL SYSTEM

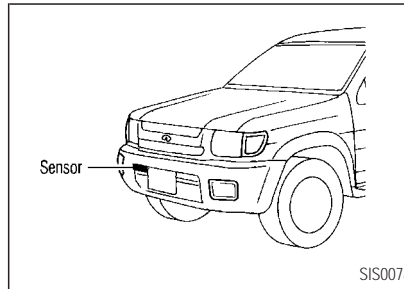

Always pay attention to the operation of the vehicle and be ready to manually control the proper following distance. The Intelligent Cruise Control (ICC) system may not be able to maintain the selected distance between

STARTING AND DRIVING

vehicles (following distance) or selected vehicle speed under some circumstances.

The ICC system uses a sensor located on the front of the vehicle to detect vehicles ahead. The sensor mainly detects the signals returned from the reflectors on a vehicle ahead. The ICC system may not be able to maintain the selected distance if the sensor cannot detect the reflector from the vehicle ahead when:

- the reflector is positioned high on the vehicle (trailer, etc.).
- the reflector is covered with dirt, snow and road spray.
- snow or road spray from other vehicles reduces the sensor's visibility.
- dense exhaust or other smoke (black smoke) from other vehicles reduces the sensor's visibility.
- if the reflector on the vehicle ahead is missing, damaged or covered.

STARTING AND DRIVING

- if excessively heavy baggage is loaded in the rear seat or the cargo area of your vehicle.

The ICC system is designed to automatically detect when the sensor is dirty or obstructed. If dirt is detected on the sensor, the system is automatically canceled. If the sensor is covered with ice, a transparent or translucent vinyl bag, etc., the ICC system may not detect them. If so, the ICC system may not cancel and may not be able to maintain the selected following distance. Clean the sensor regularly.

The ICC system is designed to maintain a selected distance and match the speed of a slower vehicle ahead; the system decelerates the vehicle as necessary. However, the ICC system can only apply up to 25% of the vehicles total braking power. Because of this, the ICC system should only be used when traffic conditions allow vehicle speeds to remain fairly constant or vehicle speeds change gradually. If a vehicle moves into the

lane ahead or if a vehicle ahead rapidly decelerates, the distance between vehicles may become closer because the ICC system cannot decelerate the vehicle quickly enough. If this occurs, the ICC system will sound a warning buzzer and blink the system display to notify the driver to take necessary action. Refer to "Approach warning" later in this section.

The ICC system does not control vehicle speed or warn you when you approach stationary and slow moving vehicles. You must pay attention to vehicle operation to maintain proper distance from vehicles ahead when approaching toll gates or traffic jams.

STARTING AND DRIVING

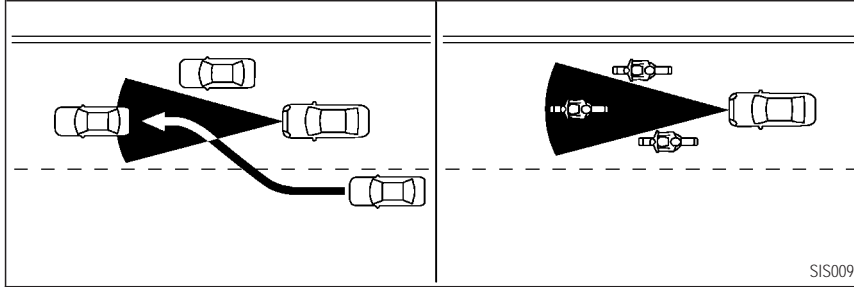

The detection zone of the ICC sensor is limited. A vehicle ahead must be in the detection zone for the ICC to maintain the selected distance and to match the speed of a vehicle ahead.

A vehicle ahead may be outside the detection zone due to its position in the lane. Motorcycles and scooters may not be detected in the lane ahead if they are traveling offset from the centerline of the lane. A vehicle that is changing lanes ahead may be outside the detection zone until it is almost completely in

the lane. If this occurs, the ICC system may warn you by blinking the system indicator and sounding the buzzer. The driver may have to manually control the proper following distance.

STARTING AND DRIVING

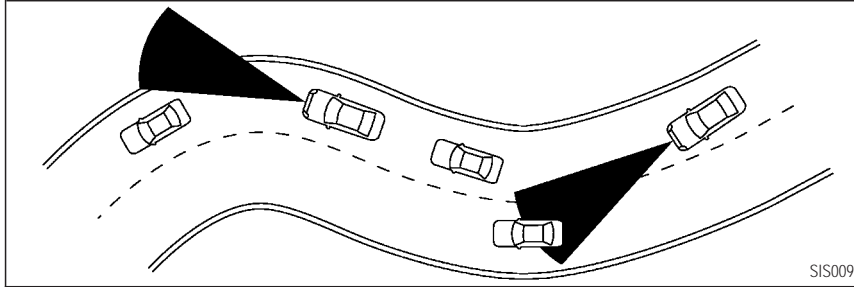

When driving on some roads, the ICC sensor may detect vehicles in a different lane, or may temporarily not detect a vehicle ahead. This may cause the ICC system to decelerate or accelerate the vehicle. These conditions could happen on winding roads, hilly roads, entering or exiting a curve, narrow roads or in road construction areas. Additionally, the detection of vehicles can be affected by the vehicle operation (steering maneuver or driving position in the lane) or the traffic condition (for example, if a vehicle ahead is being driven with some damage). The ICC system indicator

and buzzer may warn you unexpectedly. You will then have to manually control the proper distance ahead of your vehicle.

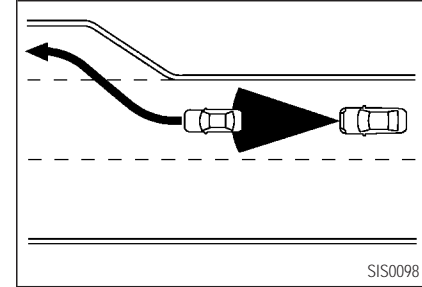

If you are driving on the freeway at a set speed and come upon a slower vehicle ahead, the ICC will attempt to match that vehicle's speed and maintain a selected following distance. If the vehicle ahead changes lanes or exits the freeway, the ICC system will accelerate the vehicle to match the set speed. Pay attention to the driving operation to maintain control of the vehicle as it accelerates to the set speed.

The vehicle may not maintain the set speed on winding or hilly roads. If this happens, drive without the ICC system.

INTELLIGENT CRUISE CONTROL SWITCH

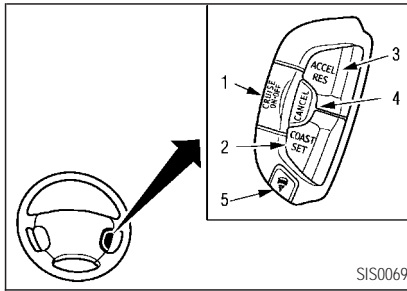

The system is operated by a master ON/OFF switch and four control switches, all mounted on the steering wheel.

1. ON/OFF switch:
Master switch to activate the system
2. COAST/SET switch:
Sets desired cruise speed, reduces speed incrementally.
3. ACCELERATE/RESUME switch:

Resumes set speed or increases speed incrementally.

4. CANCEL switch:
Deactivates system without erasing set speed.
5. DISTANCE switch:
Changes the following distance from; Maximum, Intermediate, Minimum.

STARTING AND DRIVING

INTELLIGENT CRUISE CONTROL SYSTEM DISPLAY

The display is located under the tachometer.

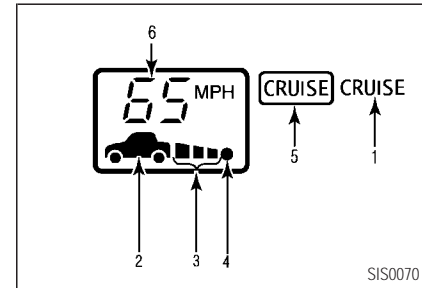

1. Intelligent Cruise Control system warning light (Orange)

The light comes on if there is a malfunction in the ICC system.

2. Vehicle ahead detection indicator

Indicates whether it detects a vehicle in front of you.

STARTING AND DRIVING

3. Set distance indicator

Displays the selected distance between vehicles set with the DISTANCE switch.

4. Indicates your vehicle

5. ON/OFF switch indicator light (Green)

Indicates that the ON/OFF switch is ON.

6. Set vehicle speed indicator

Indicates the set vehicle speed.

For Canadian models, the speed will be indicated by km/h.

When the key switch is turned ON, the display comes on as follows to check for a burned-out bulb, and it turns off when the engine is started.

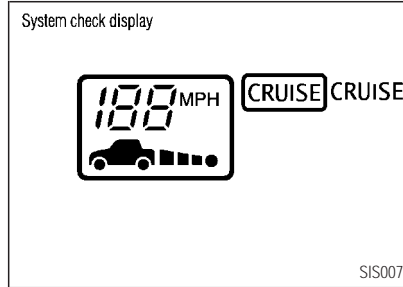

OPERATING INTELLIGENT CRUISE CONTROL SYSTEM

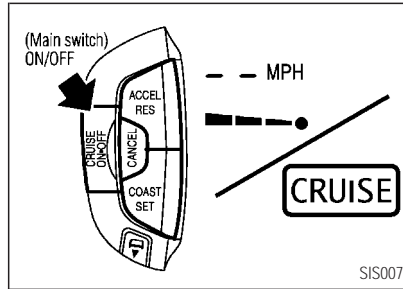

To turn on the cruise control, push the ON/OFF switch on. The cruise indicator light, set distance indicator and set vehicle speed indicator come on, and they are on a standby state for setting.

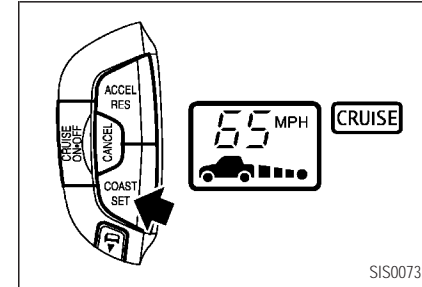

To set cruising speed, accelerate your vehicle to the desired speed, push the COAST/SET switch and release it. (Vehicle ahead detection indicator, set distance indicator and set vehicle speed indicator come on.) Take your foot off the accelerator pedal. Your vehicle will maintain the set speed.

STARTING AND DRIVING

The Intelligent Cruise Control system cannot be set under the following conditions even if the COAST/SET switch is pushed.

- When traveling outside the 25 to 90 MPH (40 to 144 km/h) speed range
- When the selector lever is not in the D (Drive) position
- While the vehicle is being braked by the driver
- When pressing the ACCEL/RES switch without there being a set speed in memory
- When the windshield wipers are switched to Low or High
- When the parking brake is applied.

System operation

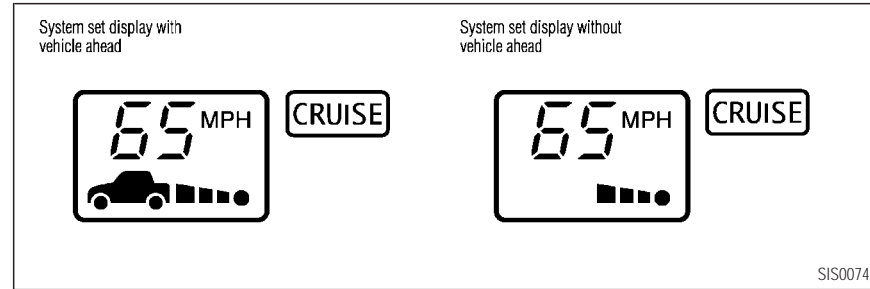

WARNING

Normally when controlling the distance to a vehicle ahead, this system automatically accelerates or decelerates your vehicle according to the speed of the vehicle ahead. Depress the accelerator or brake pedal, however, to properly accelerate or decel-

erate your vehicle when acceleration is required for a lane change or when deceleration is required to maintain a safe distance to the vehicle ahead due to its sudden deceleration or if a vehicle cuts in.

The driver sets the desired vehicle speed based on the road conditions. The ICC system maintains the set vehicle speed, similar to

STARTING AND DRIVING

standard cruise control, as long as no vehicle is detected in the lane ahead.

The ICC system displays the set speed.

Vehicle detected ahead :

When a vehicle is detected in the lane ahead, the ICC system decelerates the vehicle by controlling the throttle and applying the brakes to match the speed of a slower vehicle ahead. The system then controls the vehicle speed based on the speed of the vehicle ahead to maintain a driver selected distance.

The stoplights of the vehicle come on and the brake pedal depresses when braking is performed by the ICC system.



CAUTION

Never place your foot under the brake pedal. When the brake is operated by the Intelligent Cruise Control system,

you may get your foot caught in the pedal.

When a vehicle ahead is detected, the vehicle ahead detection indicator comes on. The ICC system will also display the set speed and selected distance.

Vehicle ahead not detected :

When a vehicle is not longer detected ahead, the ICC system gradually accelerates your vehicle to resume the previously set vehicle speed. The ICC system then maintains the set speed.

When a vehicle is no longer detected the vehicle ahead detection indicator turns off.

If a vehicle ahead appears during acceleration to the set vehicle speed or any time the ICC system is in operation, the system recontrols the distance to the vehicle.

To pass another vehicle, depress the accelerator pedal and steer the vehicle around the vehicle ahead. The set speed indicator will flash when the vehicle speed exceeds the set speed. The vehicle detect indicator will turn off when the area ahead of the vehicle is open. When the pedal is released, the vehicle will return to the previously set speed.

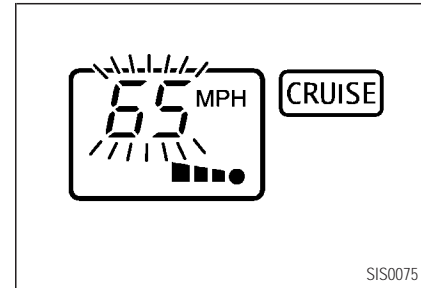

Although your vehicle may be at the set vehicle speed based on ICC system control, depress the accelerator pedal when it is necessary to accelerate your vehicle rapidly.

STARTING AND DRIVING

HOW TO CHANGE THE SET VEHICLE SPEED

To cancel the preset speed, use any of these methods:

- Push the CANCEL switch. The set vehicle speed indicator will go out.
- Tap the brake pedal. The set vehicle speed indicator will go out.
- Turn the ON/OFF switch off. Both the ON/OFF switch indicator and set vehicle speed indicator will go out.

To reset at a faster cruising speed, use one of the following methods:

- Depress the accelerator pedal. When the vehicle attains the desired speed, push and release the COAST/SET switch.
- Push and hold the ACCEL/RES switch. The set vehicle speed will increase by approximately 5 MPH (5 km/h for Canada).

- Push, then quickly release the ACCEL/RES switch. Each time you do this, the set speed will increase by approximately 1 MPH (1 km/h for Canada).

To reset at a slower cruising speed, use one of the following methods:

- Lightly tap the brake pedal. When the vehicle attains the desired speed, push the COAST/SET switch and release it.
- Push and hold the COAST/SET switch. The set vehicle speed will decrease by approximately 5 MPH (5 km/h for Canada).
- Push, then quickly release the COAST/SET switch. Each time you do this, the set speed will decrease by approximately 1 MPH (1 km/h for Canada).

To resume the preset speed, push and release the ACCEL/RES switch. The vehicle will resume the last set cruising speed when the vehicle speed is over 25 MPH (40 km/h).

HOW TO CHANGE THE SET DISTANCE TO THE VEHICLE AHEAD

The distance to the vehicle ahead can be selected at any time depending on the traffic conditions.

Each time the DISTANCE switch is pressed, the set distance will change to long, medium, short and back to long again in that sequence.

STARTING AND DRIVING

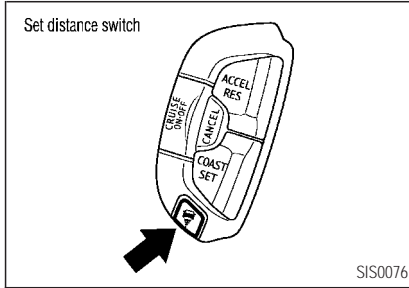

Distance	Display	Approximate distance at 60 MPH (96 km/h) [ft (m)]
Long	60 MPH CRUISE ■ ■ ■ ●	195 (60)
Middle	60 MPH CRUISE ■ ■ ●	150 (45)
Short	60 MPH CRUISE ■ ●	105 (32)

SIS0077

- The distance to the vehicle ahead will change according to the vehicle speed.

The higher the vehicle speed, the longer the distance.

- If the engine is stopped, the set distance

becomes “long”. (Each time the engine is started, the initial setting becomes long.)

APPROACH WARNING

If your vehicle comes closer to the vehicle ahead due to large deceleration of that vehicle or if another vehicle cuts in, the system warns the driver with the buzzer and ICC system display. Decelerate by depressing the brake pedal to maintain a safe vehicle distance if:

- The buzzer sounds.
- The vehicle ahead detection and set distance indicator blink.



WARNING

Do not use the Intelligent Cruise Control system when traffic conditions cause the buzzer to sound frequently.

The warning buzzer may not sound in some

cases when there is a short distance between vehicles. Some examples are:

- When the vehicles are traveling at the same speed and the distance between vehicles is not changing.
- When the vehicle ahead is traveling faster and the distance between vehicles is increasing.
- When the accelerator pedal is depressed, overriding the system.
- When a vehicle cuts in near your vehicle.

The warning buzzer will not sound when your vehicle approaches vehicles that are parked or moving slowly.

STARTING AND DRIVING

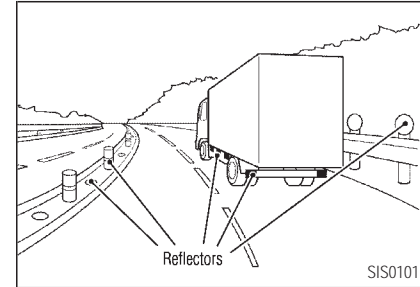

NOTE:

The approach warning chime may sound and the system display may blink when the ICC sensor detects some reflectors which are fitted on vehicles in other lanes or on the side of the road. This may cause the ICC system to decelerate or accelerate the vehicle. The ICC sensor may detect these reflectors when the vehicle is driven on winding roads, hilly roads or when entering or exiting a curve. The ICC sensor may also detect

STARTING AND DRIVING

reflectors on narrow roads or in road construction zones. In these cases you will have to manually control the proper distance ahead of your vehicle. Also, the sensor sensitivity can be affected by the vehicle operation (steering maneuver or driving position in the lane) or traffic conditions (for example, if a vehicle is being driven with some damage).

AUTOMATIC CANCELLATION

A buzzer sounds under the following conditions and the control is automatically canceled.

- When the vehicle speed is outside 20 to 90 MPH (32 to 144 km/h)
- When the selector lever is shifted to a position other than D (Drive)
- When the wiper is operated at low speed (LO) or high speed (HI) (in the intermittent (INT) position, the control is not canceled)

- When the parking brake is applied

WARNING INDICATOR

Condition A

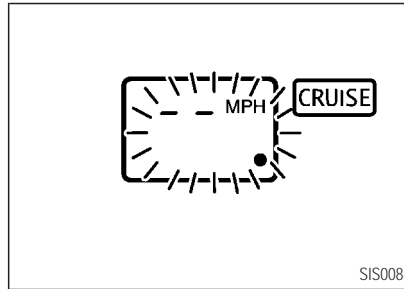

The buzzer sounds and the intelligent cruise control system is canceled automatically in the conditions described below. Part of the system display will come on or blink, making it impossible to set.

- When the ABS is in operation
- When a tire slips

- When strong light (sunlight, etc.) is directly shining on the front of the vehicle

Action to take

When the conditions listed above are no longer present, turn the system off using the Intelligent Cruise Control ON/OFF Switch. Turn the ICC system back on to use the system.

Condition B

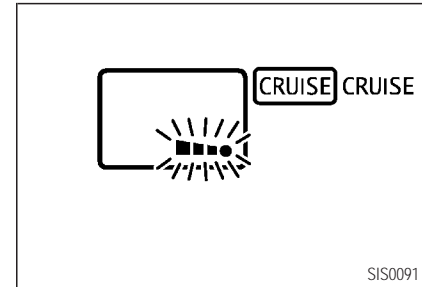

When the sensor window is dirty, making it impossible to detect a vehicle ahead, the ICC

system is automatically canceled.

The buzzer sounds and the system warning light (Orange) will come on and the set distance indicators will blink.

Action to take

If the warning light comes on, park the vehicle in a safe place and turn the engine off. Clean the dirty parts with a soft cloth and then perform the settings again.

Condition C

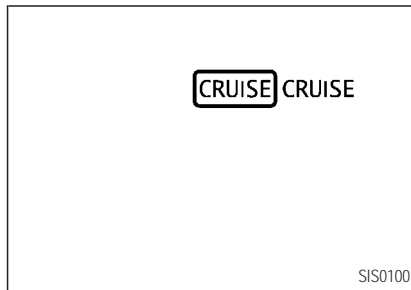

When the ICC system is not operating properly, the buzzer sounds and the system warning light (Orange) will come on.

Action to take

If the warning light comes on, park the vehicle in a safe place. Turn the engine off and then perform the settings again.

If it is not possible to set or if the indicator stays on, it may indicate that the system is malfunctioning. Although the vehicle is still driveable under normal conditions, have the vehicle checked at an authorized INFINITI retailer.

STARTING AND DRIVING

HOW TO HANDLE THE SENSOR

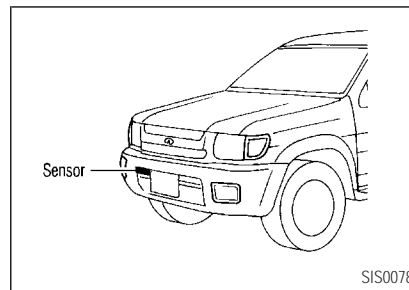

The sensor for the ICC system is located below the front bumper.

To keep the ICC system operating properly, be sure to observe the following:

- Always keep the sensor clean. Wipe dirty parts with a soft cloth carefully so as not to damage them.
- Do not impact the areas around the sensor. Do not touch or disassemble the

STARTING AND DRIVING

screw located on the sensor. Doing so could cause failure or malfunction. If the sensor installation part is deformed due to an accident, contact an authorized INFINITI retailer.

- Do not attach a sticker (including transparent material) or install an accessory near the sensor. This could cause failure or malfunction.

BREAK-IN SCHEDULE

During the first 1,200 miles (2,000 km), follow these recommendations to obtain maximum engine performance and ensure the future reliability and economy of your new vehicle. Failure to follow these recommendations may result in shortened engine life and reduced engine performance.

- Avoid driving for long periods at constant speed, either fast or slow. Do not run the engine over 4,000 rpm.

- Do not accelerate at full throttle in any gear.
- Avoid quick starts.
- Avoid hard braking as much as possible.
- Do not tow a trailer for the first 500 miles (800 km).

INCREASING FUEL ECONOMY

- Accelerate slowly and smoothly. Maintain cruising speeds with a constant accelerator position.
- Drive at moderate speeds on the highway.
- Driving at high speeds will lower fuel economy.
- Avoid unnecessary stopping and braking. Keep a safe distance behind other vehicles.
- Select a gear range suitable to road conditions.
- Avoid unnecessary prolonged engine idling.
- Keep your engine tuned up.
- Follow the recommended periodic maintenance schedule.
- Keep the tires inflated at the correct pressure. Improper tire pressure will increase wear and waste fuel.
- Make sure the front wheels are properly aligned. Improper alignment will cause premature tire wear and lower fuel economy.
- Air conditioner operation lowers fuel economy. Use the air conditioner only when necessary.
- When cruising at highway speeds, it is more economical to use the air conditioner and leave the windows closed to reduce drag.
- Use 4H position only when necessary. 4H operation lowers fuel economy.

STARTING AND DRIVING

USING FOUR WHEEL DRIVE (4WD)



CAUTION

- *Do not drive the vehicle in the 4H or 4LO position on dry hard surface roads.*

If the 4WD warning light turns on when you are driving on dry hard surface roads

- *In the AUTO or 4H position, shift the 4WD shift switch to 2WD.*
- *In the 4LO position, stop the vehicle, move the automatic transmission lever to the N position, and shift the 4WD shift switch to 2WD.*









Have your vehicle checked by an authorized INFINITI retailer as soon as possible.

TRANSFER CASE SHIFTING PROCEDURES

All mode 4WD system provides 4 positions (AUTO, 2WD, 4H and 4LO), so you can select the desired drive mode according to the driving conditions.

2WD or 4WD shift procedure

STARTING AND DRIVING

4WD Shift Switch	Wheels Driven	Indicator Light		Use Conditions	4WD Shift Procedure
		4WD shift	Transfer 4LO position		
 AUTO	Rear wheels or 4 wheels			For driving on paved or slippery roads.	Move the 4WD shift switch. 2WD ⇌ AUTO ⇌ 4H 4WD shift indicator light will indicate transfer shift position engaged. IT IS NOT NECESSARY TO MOVE THE AUTOMATIC TRANSMISSION SELECT LEVER TO THE N POSITION IN THIS OPERATION. PERFORM THIS OPERATION WHEN DRIVING STRAIGHT.
 2WD	Rear wheels			For driving on dry, paved roads (Economy drive) or state dynamometer 1/M testing.	
 4H	4 wheels			For driving on rocky, sandy or snow-covered roads.	
 4LO	Neutral		*1 May blink	Neutral disengages the automatic transmission mechanical parking lock, which will allow the vehicle to roll. Do not leave the transfer shift position in Neutral.	
	4 wheels		Illuminated	For use when maximum power and traction is required (for example on steep grades or rocky, sandy, muddy roads).	YOU CANNOT MOVE THE TRANSFER 4WD SHIFT SWITCH BETWEEN 4H AND 4LO (OR 4LO TO 4H) UNLESS YOU HAVE FIRST STOPPED THE VEHICLE AND MOVED THE AUTOMATIC TRANSMISSION SHIFT LEVER TO NEUTRAL.*2

SIS0053A

- *1: • The transfer 4LO position indicator light may blink. Stop the vehicle. Be sure to shift the 4WD shift switch after the automatic transmission lever has been shifted to the N position. If the indicator light keeps blinking after the 4WD shift procedure in the previous page, drive slowly without abrupt maneuvers for a while. Then the light will turn on or off.
- Avoid making a turn or abrupt starts while shifting to 4LO. Otherwise gears may grind, damaging the drive system.

*2: Make sure the transfer 4LO position indicator light turns on when you shift the 4WD shift switch to 4LO.

The transfer case 4WD shift switch is used to select either 2WD or 4WD depending on the driving conditions. There are four types of drive modes available, AUTO, 2WD, 4H and 4LO.

The 4WD shift switch electronically controls the transfer case operation. Rotate the switch to move between each mode, 2WD, AUTO, 4H and 4LO.

You must push the switch in to select 4LO, and the vehicle MUST be stationary and the automatic transmission selector lever is in the N position when changing into or out of 4LO.



WARNING

When parking, apply the parking brake before stopping the engine and make sure that the 4WD shift indicator light is on and the ATP warning light goes off. Otherwise, the vehicle could unexpectedly move even if the automatic transmission is in the P position.

STARTING AND DRIVING



CAUTION

- *Never shift the 4WD shift switch between 4LO and 4H while driving.*
- *The 4H position provides greater power and traction. Avoid excessive speed, as it will cause increased fuel consumption and higher oil temperatures, and could damage drivetrain components. Speed over 80 km/h (50 MPH) in 4H is not recommend.*
- *The 4LO position provides maximum power and traction. Avoid raising vehicle speed excessively, as the maximum speed is approximately 50 km/h (30 MPH).*
- *When driving straight, shift the 4WD shift switch to the 2WD, AUTO or 4H position. Do not move*

STARTING AND DRIVING

the 4WD shift switch when making a turn or reversing.

- *Do not shift the 4WD shift switch (between 2WD, AUTO and 4H) while driving on steep downhill grades. Use the engine brake and low automatic transmission gears (D1 or D2) for engine braking.*
- *Do not operate the 4WD shift switch (between 2WD, AUTO and 4H) with the rear wheels spinning.*
- *Do not drive on dry hard surface roads in the 4H or 4LO position. Driving on dry hard surfaces in 4H or 4LO may cause unnecessary noise and tire wear. We recommend driving in the 2WD or AUTO position under these conditions.*

- *Vehicles equipped with a limited slip differential (LSD) have improved driving performance on rough roads. They have increased traction performance, so when making a turn on paved roads, vibration and tire squealing may occur.*
- *The 4WD transfer case may not be shifted between 4H and 4LO at low ambient temperatures and the transfer 4LO position indicator light may blink even when the 4WD shift switch is shifted. After driving for a while you can change the 4WD transfer case between 4H and 4LO.*

When driving on rough roads,

- Set the 4WD shift switch to AUTO, 4H or 4LO.

- Drive carefully according to the road surface conditions.

When the vehicle is stuck,

- Place stones or wooden blocks under the tires to free the vehicle.
- Set the 4WD shift switch to 4H or 4LO.
- If it is difficult to free the vehicle, repeat forward and backward movement to increase the movement.
- If the vehicle is stuck deep in mud, tire chains may be effective.



CAUTION

- *Do not increase the tire rotation excessively. Tires will sink deep into the mud, making it difficult to free the vehicle.*
- *Avoid shifting gears with the en-*

gine running at high speeds as this may cause malfunction.

4WD shift switch operations

- Shift the 4WD shift switch to either the 2WD, AUTO, 4H or 4LO position, depending on driving conditions.

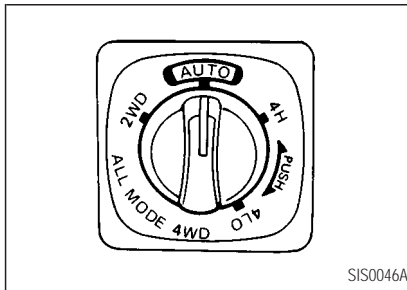

- With the switch set to the AUTO position, distribution of torque to the front and rear wheels changes automatically, depending on road conditions encountered [ratio; 0 :

100 (2WD) → 50 : 50 (4WD)]. This results in improved driving stability.

- If the 4WD shift switch is operated while making a turn, accelerating or decelerating or if the key switch is turned off while in the AUTO, 4H or 4LO, you may feel a jerk. This is not abnormal.
- When the vehicle is stopped after making a turn, you may feel a slight jolt after the selector lever is shifted to N or P. This occurs because the transfer clutch is released and not because of a malfunction.



CAUTION

- *When driving straight, shift the 4WD shift switch to the 2WD, AUTO, or 4H position. Do not move*

STARTING AND DRIVING

the 4WD shift switch when making a turn or reversing.

- *Do not shift the 4WD shift switch while driving on steep downhill grades. Use the engine brake and low automatic transmission gears (D1 or D2) for engine braking.*
- *Do not operate the 4WD shift switch with the rear wheels spinning.*
- *Before placing the 4WD shift switch in the 4H position from 2WD or AUTO, ensure the vehicle speed is less than 50 MPH (80 km/h). Failure to do so can damage the 4WD system.*
- *Never shift the 4WD shift switch between 4LO and 4H while driving.*

STARTING AND DRIVING

- *Engine idling speed is high while warming up the engine. Be especially careful when starting or driving on slippery surfaces with the 4WD shift switch set in AUTO.*

4WD shift indicator light

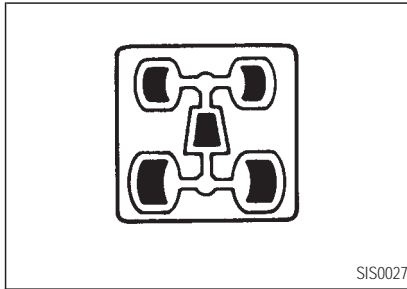

The 4WD shift indicator light is located in the tachometer.

The light should turn off within 1 second after turning the ignition switch to ON.

While the engine is running, the 4WD shift indicator light will illuminate the position selected by the 4WD shift switch.

- The 4WD shift indicator light may blink while shifting from one drive mode to the other. When the shifting is completed, the 4WD shift indicator light will come on. If the indicator light does not come on immediately, make sure the area around the vehicle is safe, and drive the vehicle straight, accelerate or decelerate or move the vehicle in reverse, then shift the 4WD shift switch.
- If the 4WD warning light comes on, the 4WD indicator light goes out.



CAUTION



- *When the 4WD shift switch is*

turned to the AUTO position at low ambient temperatures, the 4WD shift indicator light may show 4H. If this happens, all four wheels are driven as torque distribution is in the 4H position. Be careful as the vehicle may become difficult to turn. When the vehicle is driven, the 4WD shift indicator light should change to AUTO.

- *If the 4WD shift indicator light indication changes to 2WD when the 4WD shift switch is shifted to the AUTO or 4H position at low ambient temperatures, the 2WD mode may be being engaged due to malfunctioning drive system. If the indicator does not return to normal and the 4WD warning light comes on, have the system*

checked by the nearest INFINITI retailer.

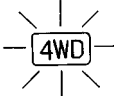
4WD warning light

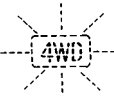
Warning light	Comes on or blinks when
 Comes on	There is a malfunction in the 4-wheel drive system.
 Blinks rapidly	The transfer oil temperature rises abnormally.
 Blinks slowly	The difference in wheel rotation is large.

SIS0028A

STARTING AND DRIVING

The 4WD warning light is located in the meter.

If the transfer shift lever is set in the N position, the 4WD warning light may illuminate. When this occurs, move the 4WD shift switch to the 4H or 4LO position.

The 4WD warning light comes on when the key switch is turned to ON. It turns off soon after the engine is started.

If any malfunction occurs in the 4WD system when the key switch is ON, the warning light will either remain illuminated or blink.

If the 4WD warning light comes on, the 4WD shift indicator light goes out.

High-temperature transfer case oil makes the warning light blink rapidly (about twice per second). If the warning light blinks rapidly during operation, stop the vehicle in a safe place immediately. Then if the light goes off after a while, you can continue driving.

STARTING AND DRIVING

A large difference between the diameters of front and rear wheels will make the warning light blink slowly (about once per two seconds). Change the 4WD shift switch into 2WD and do not drive fast.



CAUTION

- *If the warning light comes on or blinks slowly during operation or rapidly after stopping the vehicle for a while, have your vehicle checked by an authorized INFINITI retailer as soon as possible.*
- *Shifting between 4H and 4LO is not recommended when the 4WD warning light turns on.*
- *When the warning light comes on, the 2WD mode may be engaged even if the 4WD shift*

switch is in AUTO or 4H. Be especially careful when driving. If corresponding parts are malfunctioning, the 4WD mode will not be engaged even if the 4WD shift switch is shifted.

- *Do not drive on dry hard surface roads in the 4H or 4LO position.*

If the 4WD warning light turns on when you are driving on dry hard surface roads

- *in the AUTO or 4H position, shift the 4WD shift switch to 2WD.*
- *in the 4LO position, stop the vehicle, move the automatic transmission lever to the N position, and shift the 4WD shift switch to 2WD.*

- *If the warning light is still on after the above operation, have your vehicle checked by an authorized INFINITI retailer as soon as possible.*
- *The transfer case may be damaged if you continue driving with the warning light blinking rapidly.*

STARTING AND DRIVING

PARKING/PARKING ON HILLS

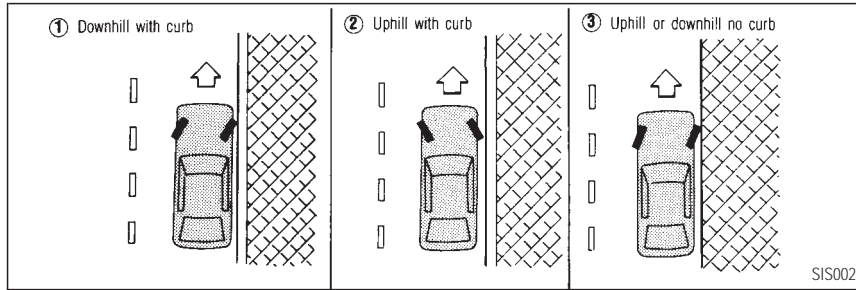

WARNING

- Do not stop or park the vehicle over flammable materials such as dry grass, waste paper or rags. They may ignite and cause a fire.
- Never leave children unattended

in the vehicle.

- Never leave the engine running while the vehicle is unattended.
1. Firmly apply the parking brake (hand brake).
 2. Move the automatic transmission select lever to the P (Park) position.



WARNING

- Safe parking procedures require that both the parking brake be set and the transmission placed into P (Park). Failure to do so could cause the vehicle to move unexpectedly or roll away and result in an accident.
- Make sure the select lever has been pushed as far forward as it can go and cannot be moved without depressing the button at the end of the lever.

All-mode 4WD models:

- If the ATP light is ON, this indicates that the automatic transmission P (park) position will not function and the transfer case is

STARTING AND DRIVING

in neutral. Make sure that the 4WD shift indicator light (and transfer 4LO position indicator) light remains illuminated before stopping the engine. Otherwise, the vehicle could unexpectedly move even if the automatic transmission is in the P (park) position.

- *Failure to engage the transfer case in 4H or 4LO could result in the vehicle moving unexpectedly, resulting in serious personal injury or property damage.*
3. To help prevent the vehicle from rolling into the street when parked on a sloping drive way, it is a good practice to turn the wheels as illustrated.
- HEADED DOWNHILL WITH CURB: ①
Turn the wheels into the curb and move

the vehicle forward until the curb side wheel gently touches the curb.

- HEADED UPHILL WITH CURB: ②
Turn the wheels away from the curb and move the vehicle back until the curb side wheel gently touches the curb.
- HEADED UPHILL OR DOWNHILL, NO CURB: ③

Turn the wheels toward the side of the road so the vehicle will move away from the center of the road if it moves.

Make sure the ATP light is off before stopping the engine.

4. Turn the ignition key to the LOCK position and remove the key.



WARNING

When parking, apply the parking

brake before stopping the engine and make sure that the 4WD shift indicator light is (and transfer 4LO position indicator light are) on. Otherwise, the vehicle could unexpectedly move even if the automatic transmission is in the P position.

POWER STEERING

The power assisted steering is designed to use a hydraulic pump, driven by the engine, to assist steering.

If the engine stops or drive belt breaks, you will still have control of the vehicle. However, much greater steering effort is needed, especially in sharp turns or at low speeds.



WARNING

If the engine is not running or is turned off while driving, the power assist for the steering will not work. Steering will be much harder to operate.

BRAKE SYSTEM

The brake system has two separate hydraulic circuits. If one circuit malfunctions, you will still have braking at two wheels.

Vacuum assisted brake

The brake booster aids braking by using engine vacuum. If the engine stops, you can stop the vehicle by depressing the brake pedal. However, greater foot pressure on the brake pedal will be required to stop the vehicle and the stopping distance will be longer.

Using the brakes

Avoid resting your foot on the brake pedal while driving. This will overheat the brakes, wear out the brake linings and pads faster and reduce gas mileage.

To help save the brakes and to prevent the brakes from overheating, before going down a slope or long grade, reduce speed and downshift to a lower gear.

Wet brakes

When the vehicle is washed or driven through water, the brakes may get wet. As a result, your braking distance will be longer and the vehicle may pull to one side during braking.

To dry brakes, drive the vehicle at a safe speed while lightly pressing the brake pedal to heat-up the brakes. Do this until the brakes return to normal. Avoid driving the vehicle at high speeds until the brakes function correctly.

STARTING AND DRIVING



WARNING

- *While driving on a slippery surface, be careful when braking, accelerating or downshifting. Abrupt braking or accelerating could cause the wheels to skid and result in an accident.*
- *If the engine is not running or is turned off while driving, the power assist for the brakes will not work. Braking will be harder.*

ANTI-LOCK BRAKE SYSTEM (ABS)

The anti-lock brake system controls the brakes at each wheel so the wheels will not lock when braking abruptly or when braking on slippery surfaces. The system detects the rotation speed at each wheel and varies the brake fluid

STARTING AND DRIVING

pressure to prevent each wheel from locking. By preventing wheel lockup, the system helps the driver maintain steering control and helps to minimize swerving and spinning on slippery surfaces.

Using the system

Depress the brake pedal and hold it down.



WARNING

Do not pump the brake pedal.

Doing so may result in increased stopping distances.

Normal operation

The anti-lock brake system will not operate at speeds below 3 to 6 MPH (5 to 10 km/h) to completely stop the vehicle. (The speeds will vary according to road conditions.) When the anti-lock system senses that one or more

wheels are close to locking up, the actuator (under the hood) rapidly applies and releases hydraulic pressure (like pumping the brakes very quickly). While the actuator is working, you may feel a pulsation in the brake pedal and hear a noise or vibration from the actuator under the hood. This is normal and indicates that the anti-lock system is working properly. However, the pulsation may indicate that road conditions are hazardous and extra care is required while driving.

If a tire slips on rough roads for more than 10 seconds, the ABS brake warning light may come on. Turn OFF the ignition key, restart the engine and drive the vehicle at speeds above 20 MPH (30 km/h). If the warning light does not go out, have the vehicle checked at an INFINITI retailer.

Self-test feature

The anti-lock brake system consists of elec-

tronic sensors, electric pumps, and hydraulic solenoids controlled by a computer. The computer has a built-in diagnostic feature that tests the system each time you start the engine and move the vehicle at a low speed in forward or reverse. When the self-test occurs, you may hear a clank noise and/or feel a pulsation in the brake pedal. This is normal and is not an indication of any malfunction. If the computer senses any malfunction, it switches the anti-lock brake system OFF and turns on the ABS brake warning light in the dashboard. The brake system will then behave normally, but without anti-lock assistance.

If the light comes on during the self check, or while you are driving, you should take your vehicle to your INFINITI retailer for repair at your earliest convenience.



WARNING

The anti-lock brake system is a sophisticated device, but it cannot prevent accidents resulting from careless or dangerous driving techniques. It can help maintain vehicle control during braking on slippery surfaces, but remember that the stopping distance on slippery surfaces will be longer than on normal surfaces, even with the anti-lock system. Stopping distances may also be longer on rough, gravel or snow covered roads, or if you are using tire chains. Always maintain a safe distance from the vehicle in front of you. Ultimately, the responsibility for safety of self and others rests in the hands of the driver.

Tire type and condition of tires may also affect braking effectiveness.

- *When replacing tires, install the specified size of tires on all four wheels.*
- *When installing a spare tire, make sure it is the proper size and type as specified on the tire placard. See "Tire placard" in the "10. Technical and consumer information" section for tire placard location information.*

COLD WEATHER DRIVING

FREING A FROZEN DOOR LOCK

To prevent a door lock from freezing, apply de-icer or glycerin through the key hole. If the lock becomes frozen, heat the key before inserting it into the key hole.

STARTING AND DRIVING

ANTI-FREEZE

When it is anticipated that the temperature will drop below 32°F (0°C), check the anti-freeze to assure proper winter protection. For details, see "Engine cooling system" in the "8. Do-it-yourself" section.

BATTERY

If the battery is not fully charged during extremely cold weather conditions, the battery fluid may freeze and damage the battery. To maintain maximum efficiency, the battery should be checked regularly. For details, see "Battery" in the "8. Do-it-yourself" section.

DRAINING OF COOLANT WATER

If the vehicle is to be left outside without anti-freeze, drain the cooling system by opening the drain valves located under the radiator and on the engine block. Refill before operating the vehicle. See "Engine cooling system"

STARTING AND DRIVING

in the "8. Do-it-yourself" section for changing engine coolant.

TIRE EQUIPMENT

1. SUMMER tires are of a tread design to provide superior performance on dry pavement. However, the performance of these tires will be substantially reduced in snowy and icy conditions. If you operate your vehicle on snowy or icy roads, INFINITI recommends the use of MUD & SNOW or ALL SEASON tires on all four wheels. Please consult your INFINITI retailer for the tire type, size, speed rating and availability information.
2. For additional traction on icy roads, studded tires may be used. However, some provinces and states prohibit their use. Check local, state and provincial laws before installing studded tires.

Skid and traction capabilities of studded snow tires, on wet or dry surfaces, may

be poorer than that of non-studded snow tires.

3. Tire chains may be used if desired. Make sure they are of proper size for the tires on your vehicle and are installed according to the chain manufacturer's suggestions.

Use of tire chains may be prohibited according to location. Check the local laws before installing tire chains. When installing tire chains, make sure they are of proper size for the tires on your vehicle and are installed according to the chain manufacturer's suggestions. **Use only SAE Class S chains.** Class "S" chains are used on vehicles with restricted tire to vehicle clearance. Vehicles that can use Class "S" chains are designed to meet the SAE standard minimum clearances between the tire and the closest vehicle suspension or body component required to accommodate the use of a winter traction device (tire chains or cables). The minimum clearances are determined using the factory equipped tire size.

Other types may damage your vehicle. Use chain tensioners when recommended by the tire chain manufacturer to ensure a tight fit. Loose end links of the tire chain must be secured or removed to prevent the possibility of whipping action damage to the fenders or underbody. If possible, avoid fully loading your vehicle when using tire chains. In addition, drive at a reduced speed. Otherwise, your vehicle may be damaged and/or vehicle handling and performance may be adversely affected.

Do not use tire chains on dry roads.

Tire chains must be installed only on the rear wheels and not on the front wheels.

Do not drive with tire chains on paved roads which are clear of snow. Driving with chains in such conditions can cause damage to the various mechanisms of the vehicle due to some overstress. When driving on clear paved roads, be sure to change to 2WD.

Four wheel drive

If you install snow tires, they must also be the same size, brand, construction and tread pattern on all four wheels.



CAUTION

ONLY use spare tires specified for each four wheel drive model.

SPECIAL WINTER EQUIPMENT

It is recommended that the following items be carried in the vehicle during winter:

- A scraper and stiff-bristled brush to remove ice and snow from the windows and wiper blades.
- A sturdy, flat board to be placed under the jack to give it firm support.
- A shovel to dig the vehicle out of snow-drifts.
- Extra window washer fluid to refill the reservoir tank.

DRIVING ON SNOW OR ICE



WARNING

- *Wet ice (32°F, 0°C and freezing rain), very cold snow or ice can be slick and very hard to drive on. The vehicle will have a lot less traction or grip under these conditions. Try to avoid driving on wet ice until the road is salted or sanded.*
- *Whatever the condition, drive with caution. Accelerate and slow down with care. If accelerating or downshifting too fast, the drive wheels will lose even more traction.*
- *Allow more stopping distance under these conditions. Braking should be started sooner than on*

STARTING AND DRIVING

dry pavement.

- *Allow greater following distances on slippery roads.*
- *Watch for slippery spots (glare ice). These may appear on an otherwise clear road in shaded areas. If a patch of ice is seen ahead, brake before reaching it. Try not to brake while actually on the ice, and avoid any sudden steering maneuvers.*
- *Do not use cruise control on slippery roads.*
- *Snow can trap dangerous exhaust gases under your vehicle. Keep snow clear of the exhaust pipe and from around your vehicle.*

STARTING AND DRIVING

ENGINE BLOCK HEATER (if so equipped)

An engine block heater to assist extreme cold temperature starting is available through your INFINITI retailer.



WARNING

Do not use your heater with an ungrounded electrical system or two-pronged (cheater) adapters. You can be injured by an electrical shock if you use an ungrounded connection.

6 IN CASE OF EMERGENCY

Roadside assistance program	6-2	If your vehicle overheats	6-10
Flat tire	6-2	Towing your vehicle	6-11
Changing a flat tire	6-2	Towing recommended by INFINITI	6-12
Jump starting	6-8	Vehicle recovery (Freeing a stuck	
Push starting	6-9	vehicle)	6-14

IN CASE OF EMERGENCY

ROADSIDE ASSISTANCE PROGRAM

Every new INFINITI comes with a 4 year, unlimited mileage Roadside Assistance plan. In the event of a roadside emergency, Roadside Assistance Service is available to you. Please refer to your Warranty Booklet for details. Both the Warranty Booklet and Roadside Assistance Calling Card in your Owner's Literature Portfolio provide the Toll-Free Number to call for assistance. Roadside Assistance is provided 24 hours a day, 365 days a year, for four years from the date sold to give emergency roadside help, in the event of mechanical or nonmechanical trouble(s) such as flat tires, out-of-gas, dead battery, lost keys mechanical breakdown, accident, etc.

FLAT TIRE

CHANGING A FLAT TIRE

If you have a flat tire, follow the instructions below.

Stopping the vehicle

1. Safely move the vehicle off the road and away from traffic.
2. Turn on the hazard warning flashers.
3. Park on a level surface and apply the parking brake. Shift the automatic transmission to P (Park).



WARNING

Make sure the 4WD shift indicator and/or transfer 4LO position indicator light remains illuminated before stopping the engine.

Make sure the ATP light is off before stopping the engine. Otherwise, the vehicle could roll unexpectedly even if the automatic transmission is in the P position. This could result in serious personal injury or property

damage.

4. Turn off the engine.



WARNING

- ***Make sure the parking brake is securely applied and the automatic transmission is shifted into P (Park).***
 - ***Never change tires when the vehicle is on a slope, ice or slippery areas. This is hazardous.***
 - ***Never change tires if oncoming traffic is close to your vehicle. Wait for professional road assistance.***
5. Raise the hood to warn other traffic, and to signal professional road assistance per-

sonnel that you need help.

6. Have all passengers get out of the vehicle and stand in a safe place, away from traffic and clear of the vehicle.

If needed, Roadside Assistance is available. Please refer to your Warranty Booklet or Roadside Assistance I.D. Card for the toll-free number to call.

Blocking wheels

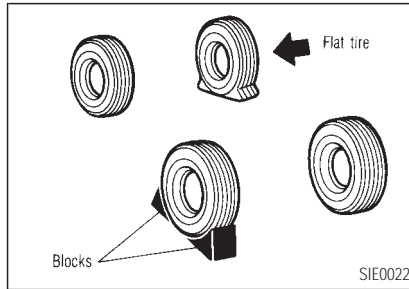

Stop the engine and pull the parking brake lever all the way on.

Place suitable blocks at both the front and back of the wheel diagonally opposite the flat tire to prevent the vehicle from rolling when it is jacked up.



WARNING

Be sure to block the wheel as the vehicle may move and cause personal injury.

Getting the spare tire and tools

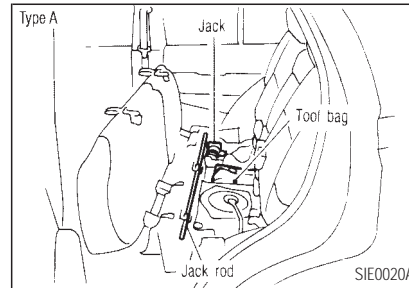

IN CASE OF EMERGENCY

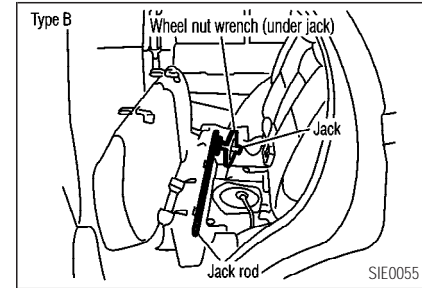

Remove jacking tools and spare tire from storage area.

IN CASE OF EMERGENCY

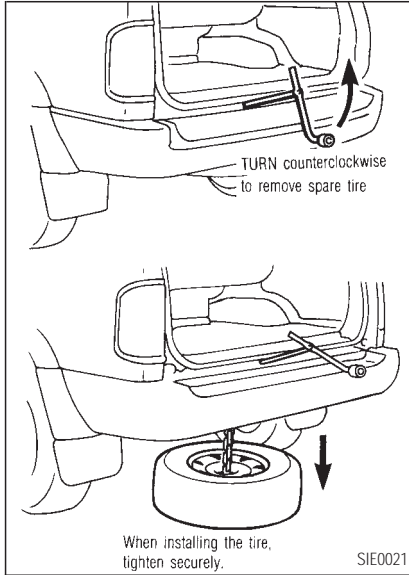

CAUTION

- Do not insert the jack rod straight as it is designed to be inserted at an angle as shown.
- Make sure the rod tip fits in the fitting portion of the spare tire hanger and turn the rod.
- Be sure to center the spare tire suspending plate on the wheel and then lift the spare tire.

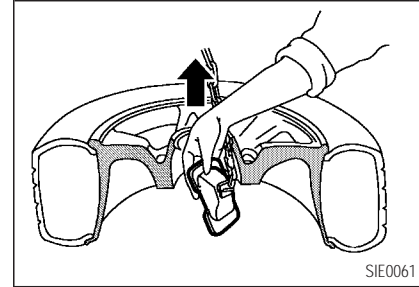

Removing wheel cap

CAUTION

Do not use your hands to pry off wheel caps. Doing so could result in personal injury.

IN CASE OF EMERGENCY

Jacking up the vehicle and removing the damaged tire

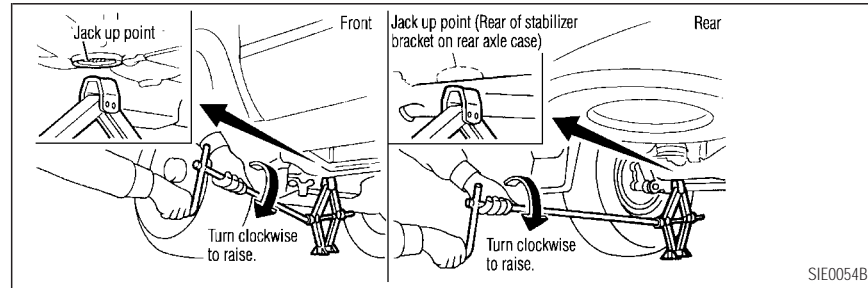
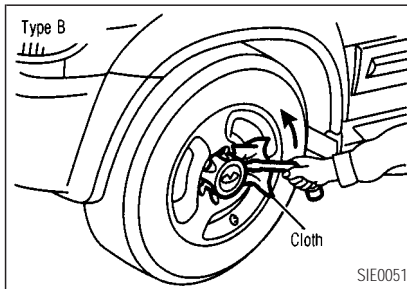
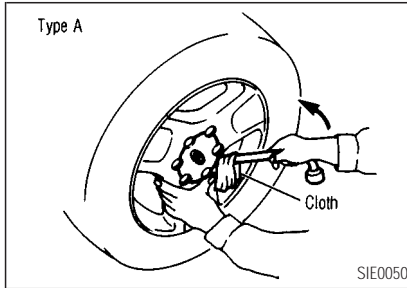

IN CASE OF EMERGENCY

WARNING

- *Never get under the vehicle while it is supported only by the jack.*
- *Use only the jack provided with your vehicle to lift the vehicle. Do not use the jack provided with your vehicle on other vehicles. The jack is designed only for lifting your vehicle during a tire change.*
- *Use the correct jack up points; never use any other part of the vehicle for jack support.*
- *Never jack up the vehicle more than necessary.*
- *Never use blocks on or under the jack.*

- *Do not start or run engine while vehicle is on the jack, as it may cause the vehicle to move. This is especially true for vehicles with limited slip differential carriers.*
- *Do not allow passengers to stay in the vehicle while it is on the jack.*

Carefully read the following instructions.

1. Place the jack directly under the jack-up point.

The jack should be used on level firm ground.

2. Loosen each wheel nut one or two turns by turning counterclockwise with the wheel nut wrench.

Do not remove the wheel nuts until the

tire is off the ground.

3. Carefully raise the vehicle until the tire clears the ground. To lift the vehicle, securely hold the jack lever and rod with both hands as shown above. Remove the wheel nuts, and then remove the wheel. Do not remove the brake drum with the wheel.

Installing the spare tire

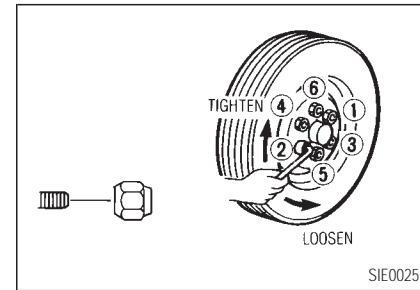

1. Clean any mud or dirt from the surface between the wheel and hub.
2. Carefully put the wheel on and tighten the

wheel nuts finger tight.

3. With the wheel nut wrench, tighten wheel nuts alternately and evenly until they are tight.
4. Lower the vehicle slowly until the tire touches the ground. Then, with the wheel nut wrench, tighten the wheel nuts securely in the sequence as illustrated.



WARNING

- *Incorrect wheel nuts or improperly tightened wheel nuts can cause the wheel to become loose or come off. This could cause an accident.*
- *Do not use oil or grease on the wheel studs or nuts. This could cause the nuts to become loose.*

As soon as possible tighten the wheel

nuts to the specified torque with a torque wrench.

**Wheel nut tightening torque:
98 ft-lb (133 N-m)**

Adjust tire pressure to the COLD pressure.

COLD pressure:

After vehicle has been parked for three hours or more or driven less than 1 mile (1.6 km).

COLD tire pressures are shown on the tire placard affixed to the glove box lid.



WARNING

Retighten the wheel nuts when the vehicle has been driven for 600 miles (1,000 km) (also in cases of a flat tire, etc.).

IN CASE OF EMERGENCY

5. Securely store the spare tire and jacking equipment in the vehicle.

When storing the 17 inch wheel, remove the cap pushing it from the inside of the wheel.



WARNING

Always make sure that the spare tire and jacking equipment are properly secured after use. Such items can become dangerous projectiles in an accident or sudden stop.

JUMP STARTING

If you try to start your engine with a booster battery, follow the instructions and precautions below:



WARNING

- *If done incorrectly, jump starting*

IN CASE OF EMERGENCY

can lead to a battery explosion, resulting in severe injury or death. It could also damage your vehicle.

- Explosive hydrogen gas is always present in the vicinity of the battery. Keep all sparks and flames away from it.
- Do not allow battery fluid to come into contact with eyes, skin, cloth or painted surfaces. Battery fluid is a corrosive sulphuric acid solution which can cause severe burns. If the fluid should come into contact with anything, immediately flush the contacted area with water.
- Keep battery out of the reach of children.

- The booster battery must be rated at 12 volts. Use of an improperly rated battery can damage your vehicle.
- Whenever working on or near a battery, always wear suitable eye protectors (for example, goggles or industrial safety spectacles) and remove rings, metal bands, or any other jewelry. Do not lean over battery when jump starting.
- Do not attempt to jump start a frozen battery. It could explode and cause serious injury.
- Your vehicle has an automatic engine cooling fan. It could come on at any time. Keep hands and other objects away from it.

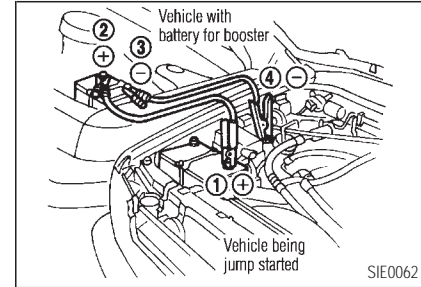

WARNING

Always follow the instructions below. Failure to do so could result in damage to the charging system and cause personal injury.

1. Position the two vehicles to bring their batteries into close proximity to each other if the booster battery is in another vehicle.

Do not allow the two vehicles to touch.

2. Apply parking brakes. Move the selector lever to P (Park). Switch off all unnecessary electrical systems (light, heater, air conditioner, etc.).
3. Remove vent caps on the battery (if so equipped). Cover the battery with an old cloth to reduce explosion hazard.
4. Connect jumper cables in the sequence as illustrated.



CAUTION

- *Always connect positive (+) to positive (+) and negative (-) to body ground (for example, strut mounting bolt, engine lift bracket, etc. — not to the battery).*

- *Make sure that cables do not touch moving parts in the engine compartment and that clamps do not contact any other metal.*

5. Start the engine of the other vehicle and let it run for a few minutes.
6. Keep the engine speed of the other vehicle at about 2,000 rpm, and start your engine in the normal manner.



CAUTION

Do not keep starter motor engaged for more than 10 seconds. If the engine does not start right away, turn the key off and wait 3 to 4 seconds before trying again.

7. After starting your engine, carefully dis-

IN CASE OF EMERGENCY

connect the negative cable and then the positive cable.

8. Replace the vent caps (if so equipped). Be sure to dispose of the cloth used to cover the vent holes as it may be contaminated with corrosive acid.

PUSH STARTING



CAUTION

- *Automatic transmission models cannot be push started. This may cause transmission damage.*
- *Three way catalyst equipped models should not be started by pushing since the three way catalyst may be damaged.*
- *Never try to start the vehicle by towing it; when the engine starts,*

IN CASE OF EMERGENCY

the forward surge could cause the vehicle to collide with the tow vehicle.

IF YOUR VEHICLE OVERHEATS

If your vehicle is overheating indicated by an extremely high temperature gauge reading, or if you feel a lack of engine power, detect abnormal noise, etc., take the following steps:



WARNING

- *Do not continue to drive if your vehicle overheats. Doing so could cause a vehicle fire.*
- *To avoid the danger of being scalded, never remove the radiator cap while the engine is still*

hot. When the radiator cap is removed, pressurized hot water will spurt out, possibly causing serious injury.

- *Do not open the hood if steam is coming out.*

1. Move the vehicle safely off the road, apply the parking brake and move the gearshift lever to the neutral position (automatic transmission to P (Park)).

Do not stop the engine.

2. Turn off the air conditioner switch. Open all the windows, move the heater or air conditioner temperature control to maximum hot and fan control to high speed.
3. If engine overheating is caused by climbing a long hill on a hot day, run the engine at a fast idle (approximately 1,500 rpm)

until the temperature gauge indication returns to normal.

4. Get out of the vehicle. Look and listen for steam or coolant escaping from the radiator before opening the hood. Wait until no steam or coolant can be seen before proceeding.

5. Open the engine hood.



WARNING

If steam or water is coming from the engine, stand clear to prevent getting burned.

6. Visually check drive belts for damage or looseness. Also check if the cooling fan is running. The radiator hoses and radiator should not leak water. If coolant is leaking, the cooling fan belt is missing or loose or

the cooling fan does not run, stop the engine.



WARNING

- ***Be careful not to allow your hands, hair, jewelry or clothing to come into contact with, or to get caught in, the cooling fan or drive belt.***
- ***The engine cooling fan can start at any time when the coolant temperature is high.***

7. After the engine cools down, check the coolant level in the reservoir tank with the engine running. Add coolant to the reservoir tank if necessary. Have your vehicle repaired at the nearest INFINITI retailer.

TOWING YOUR VEHICLE

When towing your vehicle, all State (Provin-

cial in Canada) and local regulations for towing must be followed. Incorrect towing equipment could damage your vehicle. Towing instructions are available from your INFINITI dealer. Local service operators are generally familiar with the applicable laws and procedures for towing. To assure proper towing and to prevent accidental damage to your vehicle, INFINITI recommends having a service operator tow your vehicle. It is advisable to have the service operator carefully read the following precautions.



WARNING

- ***Never ride in a vehicle that is being towed.***
- ***Never get under your vehicle after it has been lifted by a tow truck.***

IN CASE OF EMERGENCY



CAUTION

- ***When towing, make sure that the transmission, axles, steering system and powertrain are in working condition. If any unit is damaged, dollies must be used.***
- ***Always attach safety chains before towing.***

If needed, Roadside Assistance is available. Please see your Warranty Information Booklet or Roadside Assistance I.D. Card for the toll-free number to call.

IN CASE OF EMERGENCY

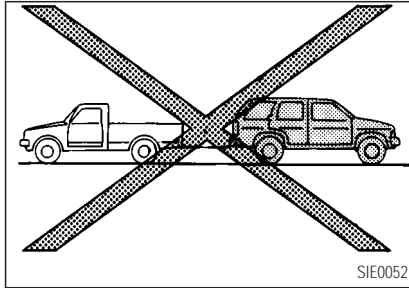

TOWING RECOMMENDED BY INFINITI

Two wheel drive models

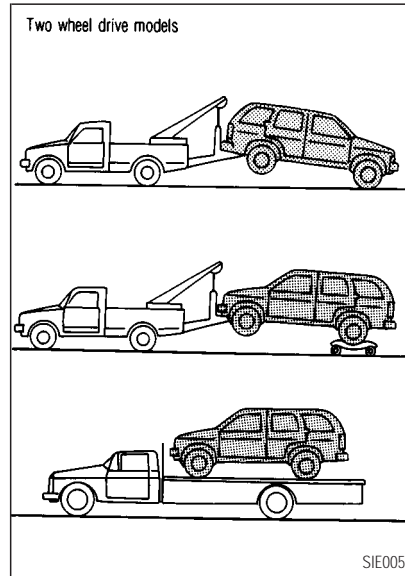

INFINITI recommends that your vehicle be towed with the driving (rear) wheels off the ground or be placed on a flat bed truck as illustrated.

CAUTION

- ***Never tow automatic transmission models with the rear wheels on the ground or four wheels on the ground (forward or backward), as this may cause serious and expensive damage to the transmission. If it is necessary to tow the vehicle with the front wheels raised, always use towing dollies under the rear wheels.***
- ***When towing automatic transmission models with the front wheels on the ground or on towing dollies:***

IN CASE OF EMERGENCY

- Turn the ignition key to the OFF position, and secure the steering wheel in a straight ahead position with a rope or similar device. Never secure the steering wheel by turning the ignition key to the LOCK position. This may damage the steering lock mechanism.

If the speed or distance must necessarily be greater, remove the propeller shaft before towing to prevent damage to the transmission.

Four wheel drive models

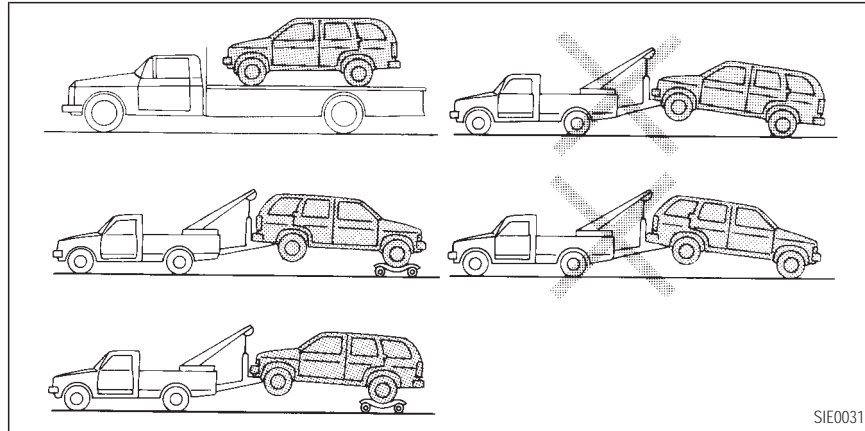

SIE0031

INFINITI recommends that towing dollies be used when towing your vehicle or the vehicle be placed on a flat bed truck as illustrated.



CAUTION

Never tow All-mode 4WD models with any of the wheels on the ground

IN CASE OF EMERGENCY

as this may cause serious and expensive damage to the transfer case.

VEHICLE RECOVERY (Freeing a stuck vehicle)

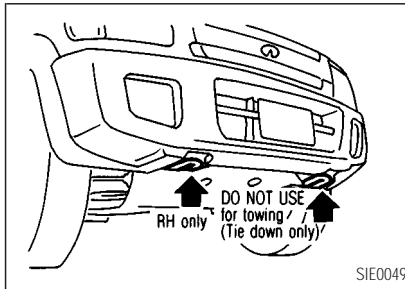

WARNING

- Stand clear of a stuck vehicle.

- Do not spin your tires at high speed. This could cause them to explode and result in serious injury. Parts of your vehicle could also overheat and be damaged.

CAUTION

- Use the towing hook only, not other parts of the vehicle. Otherwise, the vehicle body will be damaged.
- Use the towing hook only to free a vehicle stuck in sand, snow, mud, etc. Never tow the vehicle for a long distance using only the towing hook.
- The towing hook is under tremendous force when used to free a stuck vehicle. Always pull the

cable straight out from the front of the vehicle. Never pull on the hook at an angle.

7 APPEARANCE AND CARE

Cleaning exterior.....	7-2	Floor mats.....	7-4
Washing.....	7-2	Seat belts.....	7-5
Waxing.....	7-3	Corrosion protection.....	7-5
Removing spots.....	7-3	Most common factors contributing to	
Underbody.....	7-3	vehicle corrosion.....	7-5
Glass.....	7-3	Environmental factors influence the rate of	
Aluminum alloy wheels.....	7-3	corrosion.....	7-5
Chrome parts.....	7-3	To protect your vehicle from	
Cleaning interior.....	7-4	corrosion.....	7-5

APPEARANCE AND CARE

CLEANING EXTERIOR

In order to maintain the appearance of your vehicle, it is important to take proper care of it.

In the following cases, please wash your vehicle as soon as possible to protect the paint surface.

- After a rainfall to prevent possible damage from acid rain.
- After driving on coastal roads
- When contaminants such as soot, bird droppings, tree sap, metal particles or bugs get on the paint surface
- When dust or mud builds up on the surface

Whenever possible, store or park your vehicle inside a garage or in a covered area.

When it is necessary to park outside, park in

a shady area or protect the vehicle with a body cover.

Be careful not to scratch the paint surface when putting on or removing the body cover.

WASHING

Thoroughly rinse surface dirt off the vehicle with a wet sponge and plenty of clean water. Clean the vehicle thoroughly using a mild soap such as Nissan Car Wash, or a general purpose dishwashing liquid mixed with clean, lukewarm (never hot) water. Rinse the vehicle again with plenty of clean water.

Inside flanges, seams and folds on the doors, hatches and hood are particularly vulnerable to the effects of road salt. Therefore, these areas must be regularly cleaned. Make sure that the drain holes in the lower edge of the door are open. Spray water under the body and in the wheel wells to loosen the dirt and wash away road salt.

Avoid leaving water spots on the paint surface by using a damp chamois to dry the vehicle.



CAUTION

- ***Do not use strong household soap, strong chemical detergents, gasoline or solvents.***
- ***Do not wash the vehicle in direct sunlight or while the vehicle body is hot, as the surface may become water-spotted.***
- ***Avoid using tight-napped or rough cloths, such as washing mitts. Care must be taken when removing caked-on dirt or other foreign substances so that the paint surface is not scratched or damaged.***

APPEARANCE AND CARE

WAXING

If you wish to wax your vehicle, only use a wax specified for use over clear coats, such as Nissan Liquid or Spray Wax, because your INFINITI has been finished with the finest paint and hard clear coats. Your INFINITI retailer can assist you in choosing the proper product.

- Wax your vehicle only after a thorough washing. Follow the instructions supplied with the wax.
- Do not use a wax containing any abrasives, cutting compounds or cleaners that may damage the vehicle finish.
- If the surface does not polish easily, use a “road tar” remover and wax again.

Machine compounding or aggressive polishing on a base coat/clear coat paint finish may dull the finish or leave swirl marks.

REMOVING SPOTS

Remove tar and oil spots, industrial dust, insects, and tree sap as quickly as possible from the paint surface to avoid lasting damage or staining. Special cleaning products are available at your INFINITI retailer or automotive accessory stores.

UNDERBODY

In areas where road salt is used in winter, the underbody must be cleaned regularly. This will prevent dirt and salt from building up and causing underbody and suspension corrosion. Before the winter period and again in the spring, the underseal must be checked and, if necessary, re-treated.

GLASS

Use glass cleaner to remove smoke and dust film from the glass surfaces. It is normal for glass to become coated with a film after the vehicle is parked in the hot sun. Glass cleaner and a soft cloth will easily remove this film.



CAUTION

When cleaning the inside of the window, do not use sharp-edged tools, abrasive cleaners or chlorine based disinfectant cleaners. They could damage the electrical conductors, radio antenna elements or the rear window defogger elements.

ALUMINUM ALLOY WHEELS

Wash regularly, especially during winter months in areas where road salt is used. Salt could discolor the wheel if not removed.

CHROME PARTS

Clean chrome parts regularly with a non-abrasive chrome polish to maintain the finish.

APPEARANCE AND CARE

CLEANING INTERIOR

Occasionally remove loose dust from the interior trim, plastic parts and seats using a vacuum cleaner or soft brush. Wipe the vinyl and leather surfaces with a clean, soft cloth dampened in mild soap solution, then wipe clean with a dry soft cloth. Before using any fabric protector, read the manufacturer's recommendations. Some fabric protectors contains chemicals that stain or bleach the seat material. Use a cloth dampened only with water, to clean the meter and gauge lens.

CAUTION

- *Never use gasoline, thinner or any similar material.*
- *The leather seats should be regularly coated with a leather wax*

like saddle soap. Never use car wax.

- *Never use fabric protectors unless recommended by the manufacturer.*
- *Do not use glass or plastic cleaner on meter or gauge lens covers. It may damage the lens cover.*

FLOOR MATS

The use of genuine floor mats can extend the life of your vehicle carpet and make it easier to clean the interior. **No matter what mats are used, be sure they are fitted for your vehicle and are properly positioned in the footwell to prevent interference with pedal operation.** Mats should be maintained with regular cleaning and replaced if they become excessively worn.

Floor mat positioning aid

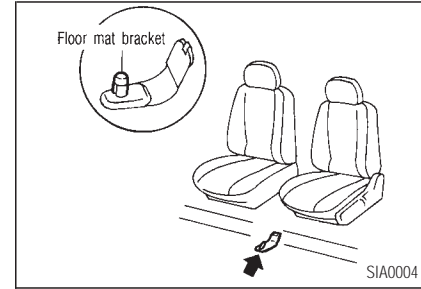

This model includes a front floor mat bracket to act as a floor mat positioning aid. INFINITI floor mats have been specially designed for your vehicle model. The driver side floor mat has a grommet hole incorporated in it. Simply position the mat by placing the floor mat bracket through the floor mat grommet hole while centering the mat in the floorpan contour.

Periodically check to make certain that the mats are properly positioned.

SEAT BELTS

The seat belts can be cleaned by wiping them with a sponge dampened in a mild soap solution. Allow the belts to dry completely before using them.



WARNING

Do not allow wet belts to roll up in the retractor. NEVER use bleach, dye, or chemical solvents since these may severely weaken the seat belt webbing.

CORROSION PROTECTION

MOST COMMON FACTORS CONTRIBUTING TO VEHICLE CORROSION:

1. The accumulation of moisture-retaining dirt and debris in body panel sections,

cavities, and other areas.

2. Damage to paint and other protective coatings caused by gravel and stone chips or minor traffic accidents.

ENVIRONMENTAL FACTORS INFLUENCE THE RATE OF CORROSION:

Moisture

Accumulation of sand, dirt and water on the vehicle body underside can accelerate corrosion. Wet floor coverings will not dry completely inside the vehicle, and should be removed for drying to avoid floor panel corrosion.

Relative humidity

Corrosion will be accelerated in areas of high relative humidity, especially those areas where the temperatures stay above freezing where atmospheric pollution exists, or where road salt is used.

APPEARANCE AND CARE

Temperature

A temperature increase will accelerate the rate of corrosion to those parts which are not well ventilated.

Air pollution

Industrial pollution, the presence of salt in the air in coastal areas, or heavy road salt use will accelerate the corrosion process. Road salt will also accelerate the disintegration of paint surfaces.

TO PROTECT YOUR VEHICLE FROM CORROSION:

- Wash your vehicle often to keep the vehicle clean.
- Always check for minor damage to the paint and repair it as soon as possible.
- Keep drain holes at the bottom of the doors open to avoid water accumulation.
- Check the underbody for accumulation of

APPEARANCE AND CARE

sand, dirt or salt. If present, wash with water as soon as possible.



CAUTION

- ***NEVER remove dirt, sand or other debris from the passenger compartment by washing it out with a hose. Remove dirt with a vacuum cleaner or broom.***
- ***Never allow water or other liquids to come in contact with electronic components inside the vehicle as this may damage them.***
- ***See your INFINITI retailer for assistance.***

Chemicals used for road surface de-icing are extremely corrosive. They accelerate corrosion and deterioration of underbody components such as the exhaust system, fuel and brake

lines, brake cables, floor pan and fenders.

In winter, the underbody must be cleaned periodically.

For additional protection against rust and corrosion, which may be required in some areas, consult your local INFINITI retailer.

8 DO-IT-YOURSELF

Maintenance precautions	8-2	Windshield wiper blades	8-16
Engine compartment check locations	8-4	Cleaning	8-16
Engine cooling system	8-5	Replacing	8-17
Checking engine coolant level	8-5	Parking brake and brake pedal	8-18
Changing engine coolant	8-6	Checking parking brake	8-18
Engine oil	8-7	Checking brake pedal	8-18
Checking engine oil level	8-7	Brake booster	8-19
Changing engine oil	8-8	Fuses	8-19
Changing engine oil filter	8-9	Engine compartment	8-19
Automatic transmission fluid	8-10	Passenger compartment	8-21
Temperature conditions for		Multi-remote controller battery	
checking	8-10	replacement	8-21
Power steering fluid	8-11	Lights	8-22
Brake fluid	8-12	Headlights	8-22
Window washer fluid	8-12	Exterior and interior lights	8-23
Battery	8-13	Wheels and tires	8-29
Jump starting	8-14	Tire pressure	8-29
Drive belts	8-14	Types of tires	8-30
Spark plugs	8-15	Tire chains	8-31
Replacing spark plugs	8-15	Changing wheels and tires	8-31
Air cleaner	8-15		

DO-IT-YOURSELF

MAINTENANCE PRECAUTIONS

When performing any inspection or maintenance work on your vehicle, always take care to prevent serious accidental injury to yourself or damage to the vehicle. The following are general precautions which should be closely observed.



WARNING

- *Park the vehicle on a level surface, apply the parking brake securely and block the wheels to prevent the vehicle from moving. Move the selector lever to the P (Park) position.*
- *Be sure to turn the ignition key to the OFF or LOCK position when performing any replacement or repair.*

- *If you must work with the engine running, keep your hands, clothing, hair and tools away from moving fans, belts and any other moving parts.*
- *It is advisable to secure or remove any loose clothing and any jewelry, such as rings, watches, etc. before working on your vehicle.*
- *Always wear eye protection whenever you work on your vehicle.*
- *If you must run the engine in an enclosed space such as a garage, be sure there is proper ventilation for exhaust gases to escape.*
- *Never get under the vehicle while it is supported only by a jack. If it*

is necessary to work under the vehicle, support it with safety stands.

- *Keep smoking materials, flame and sparks away from fuel and battery.*
- *The fuel filter or fuel lines should be serviced by an INFINITI retailer because the fuel lines are under high pressure even when the engine is off.*



CAUTION

- *Do not work under the hood while the engine is hot. Turn off the engine and wait until it cools down.*
- *Never connect or disconnect ei-*

DO-IT-YOURSELF

ther the battery or any transistorized component connector while the ignition is on.

- *Never leave the engine or automatic transmission related component harness connector disconnected while the ignition key is on.*
- *Never leave the engine or the automatic transmission related component harness connector disconnected while the ignition key is on.*
- *Avoid direct contact with used engine oil and coolant. Improperly disposed engine oil, engine coolant, and/or other vehicle fluids can hurt the environment. Always conform to local regulations for disposal of vehicle fluid.*

This "8. Do-it-yourself" section gives instructions regarding only those items which are relatively easy for most owners to perform. More involved service should be done by your INFINITI retailer.

A genuine INFINITI Service Manual is also available. See "Owner's Manual/Service Manual order information" in the "10. Technical and consumer information" section.

You should be aware that incomplete or improper servicing may result in operating difficulties or excessive emissions, and could affect your warranty coverage. **If in doubt about any servicing, have it done by your INFINITI retailer.**

DO-IT-YOURSELF

ENGINE COMPARTMENT CHECK LOCATIONS

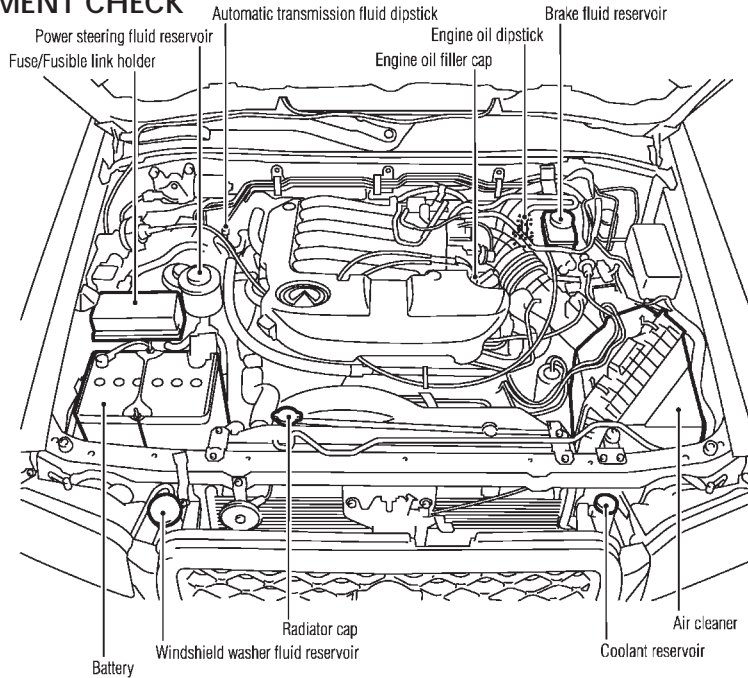

SID0201

DO-IT-YOURSELF

ENGINE COOLING SYSTEM

The engine cooling system is filled at the factory with a high-quality, year-round, anti-freeze coolant solution. The anti-freeze solution contains rust and corrosion inhibitors, therefore additional cooling system additives are not necessary.

CAUTION

When adding or replacing coolant, use only genuine NISSAN anti-freeze coolant or equivalent with the proper mixture ratio of 50% antifreeze and 50% demineralized water/distilled water.

The use of other types of coolant solutions may damage your engine cooling system.

Outside temperature down to		Anti-freeze	Demineralized water/ distilled water
°C	°F		
-35	-30	50%	50%

WARNING

- *Never remove the radiator cap when the engine is hot. Serious burns could be caused by high pressure fluid escaping from the radiator. Wait until the engine and radiator cool down. See "If your vehicle overheats" in the "6. In case of emergency" section.*
- *The radiator is equipped with a pressure cap. To prevent engine damage, use only a genuine INFINITI radiator cap.*

CHECKING ENGINE COOLANT LEVEL

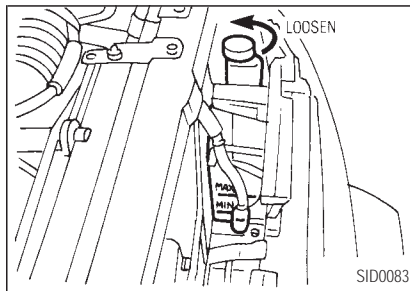

Check the coolant level in the reservoir tank when the engine is cold. If the coolant level is below MIN, add coolant up to the MAX level. If the reservoir tank is empty, check the coolant level in the radiator **when the engine is cold**. If there is insufficient coolant in the radiator, fill the radiator with coolant up to the filler opening and also add it to the reservoir tank up to the MAX level.

If the cooling system requires coolant

DO-IT-YOURSELF

frequently, have it checked by your INFINITI retailer.

CHANGING ENGINE COOLANT

- Major cooling system repairs should be performed by your INFINITI retailer. The service procedures can be found in the appropriate INFINITI Service Manual.
- Improper servicing can result in reduced heater performance and engine overheating.



WARNING

- *To avoid the danger of being scalded, never change the coolant when the engine is hot.*
- *Never remove the radiator cap when the engine is hot. Serious burns could be caused by high*

pressure fluid escaping from the radiator.

- *Avoid direct skin contact with used coolant. If skin contact is made, wash thoroughly with soap or hand cleaner as soon as possible.*
- *Keep coolant out of reach of children and pets.*

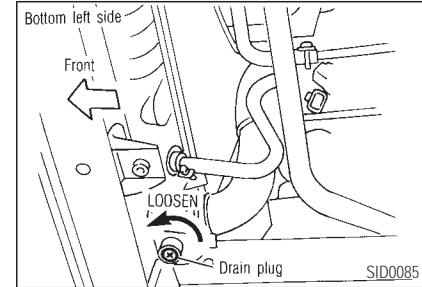
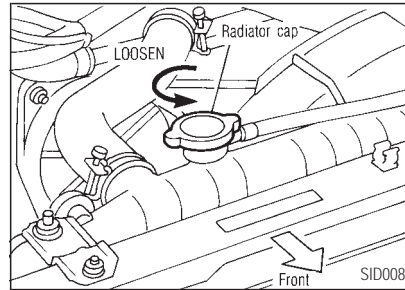

When changing engine coolant, be sure the ignition switch is off.

1. Open radiator drain plug at the bottom of radiator, and remove radiator filler cap.
- **Be careful not to allow coolant to contact drive belts.**
 - **Waste coolant must be disposed of properly. Check your local regulations.**
2. Close the radiator drain plug securely after the coolant is drained.

- Fill the radiator slowly with the proper mixture of anti-freeze solution and demineralized water/distilled water. Fill the reservoir tank up to the MAX level. Then install the radiator filler cap.
- Start the engine and warm it up until it reaches normal operating temperature. Then race the engine two or three times under no load. Watch the engine coolant temperature gauge for signs of overheating.
- Stop the engine. **After it completely cools down**, refill the radiator up to the filler opening. Fill the reservoir tank up to the MAX level.
- Check the drain plug for any sign of leakage.
- Recheck the coolant level after the vehicle has been driven for a day.

ENGINE OIL

CHECKING ENGINE OIL LEVEL

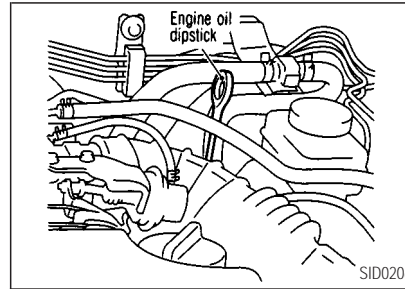

- Park the vehicle on a level surface and apply parking brake.
- Run the engine until it reaches operating temperature.
- Turn off the engine. **Wait more than 10 minutes for the oil to drain back into the oil pan.**

DO-IT-YOURSELF

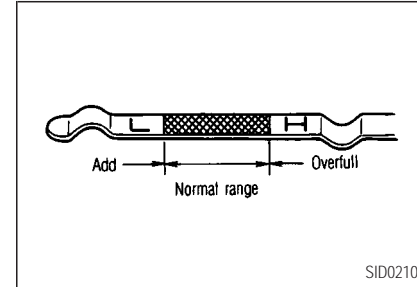

- Remove the dipstick and wipe it clean. Reinsert it all the way.
- Remove the dipstick again and check the oil level. It should be between the H and L marks. If the oil level is below the L mark, remove the oil filler cap and pour recommended oil through the opening. **Do not overfill.**
- Recheck oil level with dipstick.

It is normal to add some oil between oil maintenance intervals or during the

DO-IT-YOURSELF

break-in period, depending on the severity of operating conditions.



Oil level should be checked regularly. Operating with insufficient amount of oil can damage the engine, and such damage is not covered by warranty.

CHANGING ENGINE OIL

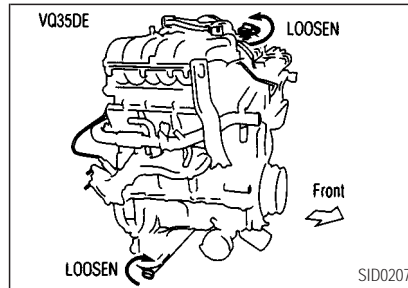

1. Park the vehicle on a level surface and apply the parking brake.
2. Run the engine until it reaches operating temperature, and then turn it off and wait more than 10 minutes.
3. Place a large drain pan under the drain plug.
4. Remove the oil filler cap.
5. Remove the drain plug with a wrench and completely drain the oil.

If oil filter is to be changed, remove and replace it at this time. See later in this section for changing engine oil filter.



Be careful not to burn yourself. The engine oil will be hot.

- **Waste oil must be disposed of properly.**
- **Check your local regulations.**

6. Clean and re-install the drain plug and a new washer. Securely tighten the drain plug with a wrench.

**Drain plug tightening torque:
22 to 29 ft-lb (29 to 39 N·m)**

Do not use excessive force.

7. Refill the engine with recommended oil and install the cap securely.

See “Capacities and recommended fuel/lubricants” in the “10. Technical and consumer information” section for drain and refill capacity.

The drain and refill capacity depends on the oil temperature and drain time. Use these specifications for reference only. Always use the dipstick to determine when the proper amount of oil is in the engine.

8. Start the engine.
Check for leakage around the drain plug.
Correct as required.
9. Turn the engine off and wait more than 10 minutes. Check the oil level with the dipstick. Add engine oil if necessary.
10. Dispose of waste oil in the proper manner.



WARNING

- *Prolonged and repeated contact with used engine oil may cause skin cancer.*
- *Try to avoid direct skin contact with used oil. If skin contact is made, wash thoroughly with soap or hand cleaner as soon as possible.*
- *Keep used engine oil out of reach of children.*

CHANGING ENGINE OIL FILTER

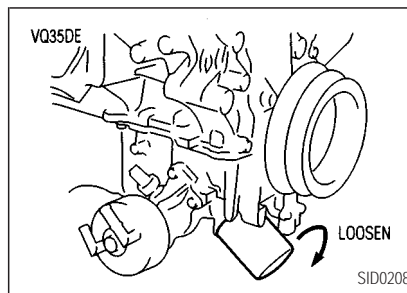

1. Park the vehicle on a level surface and apply the parking brake.
2. Turn the engine off.
3. Loosen the oil filter with an oil filter wrench. (Depending on the engine model, a special cap-type wrench may be required. See your INFINITI retailer.) Then remove the oil filter by turning it by hand.

DO-IT-YOURSELF



CAUTION

Be careful not to burn yourself. The engine oil will be hot.

4. Wipe the engine oil filter mounting surface with a clean rag.

Be sure to remove any old rubber gasket remaining on the mounting surface of the engine.

5. Coat the rubber gasket on the new filter with clean engine oil.
6. Screw in the oil filter until a slight resistance is felt, then tighten additionally more than 2/3 turn.

Oil filter tightening torque:

10.85 to 15.11 ft-lb (14.7 to 20.5 N·m)

DO-IT-YOURSELF

7. Start the engine and check for leakage around the oil filter. Correct as required.
8. Turn the engine off and wait several minutes. Check the oil level. Add engine oil if necessary.

AUTOMATIC TRANSMISSION FLUID



WARNING

- *When engine is running, keep hands, jewelry and clothing away from any moving parts such as fan and drive belt.*
- *Automatic transmission fluid is poisonous and should be stored carefully in marked containers out of the reach of children.*

TEMPERATURE CONDITIONS FOR CHECKING

The fluid level should be checked using the HOT range (L & H marks) on the dipstick at fluid temperatures between 122 and 176°F (50 and 80°C) after the vehicle has been driven approximately 5 minutes in urban areas after the engine is warmed up. The level can be checked at fluid temperatures between 86 and 122°F (30 and 50°C) using the “COLD” range on the dipstick for reference, after the engine is warmed up but before driving. However, the fluid level must be rechecked using the HOT range.

1. Park the vehicle on a level surface and set the parking brake.
2. Start the engine and then move the selector lever through each gear range ending in P (Park).

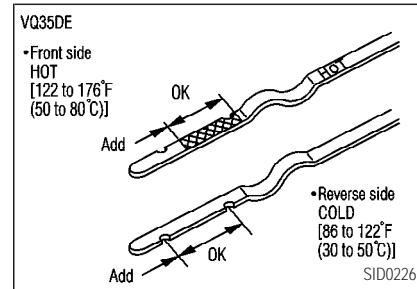
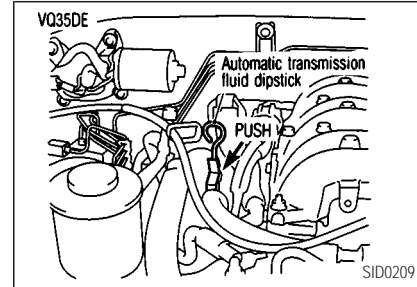

3. Check the fluid level with the engine idling.

4. Expand the spring stopper and remove the dipstick. Wipe it clean with lint-free paper.
5. Reinsert the dipstick into the charging pipe as far as it will go.
6. Remove the dipstick and note the reading. If the level is at the low side of either range, add fluid to the charging pipe.
7. When inserting the dipstick, set it so that the spring stopper presses the upper part of the dipstick rubber to lock the dipstick.



CAUTION

- Do not overfill.
- Use only Nissan Matic "D" (Continental US and Alaska) or Canada Nissan Automatic Transmission Fluid. Dexron™III/Mercon™ or equivalent may also

be used. Outside the continental US and Alaska contact an INFINITI retailer for more information regarding suitable fluids, including recommended brand(s) of Dexron™III/Mercon™ automatic transmission fluid.

NOTE:

If the vehicle has been driven for a long time at high speeds, or in city traffic in hot weather, or if it is being used to pull a trailer, an accurate fluid level cannot be read. You should wait until the fluid has cooled down (about 30 minutes).

DO-IT-YOURSELF

POWER STEERING FLUID

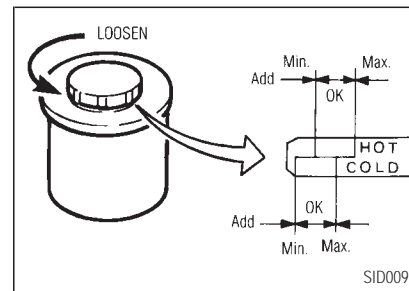

The fluid level should be checked using the HOT range on the dipstick at fluid temperature of 122 to 176°F (50 to 80°C) or using the COLD range on the dipstick at fluid temperature of 32 to 86°F (0 to 30°C).

DO-IT-YOURSELF

CAUTION

- Do not overfill.
- Use Genuine Nissan PSF II or equivalent.

BRAKE FLUID

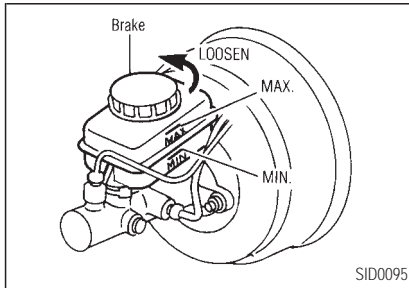

Check the fluid level in the reservoir. If the fluid is below the MIN. line or the brake warning light comes on, add Genuine Nissan

Brake Fluid or equivalent DOT 3 fluid up to the MAX. line. If fluid must be added frequently, the system should be checked by your INFINITI retailer.

WARNING

Use only new fluid from a sealed container. Old, inferior, or contaminated fluid may damage the brake system. The use of improper fluids can damage the brake system and affect the vehicle's stopping ability.

CAUTION

Do not spill the fluid on painted surfaces. This will damage the paint. If fluid is spilled, wash the surface with mild soap and water immediately.

WINDOW WASHER FLUID

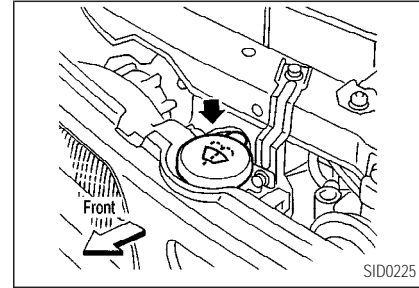

Add fluid when the low washer fluid warning light comes on. Add a washer solvent to the water for better cleaning. In the winter season, add a windshield washer anti-freeze. Follow the manufacturer's instructions for the mixture ratio.

DO-IT-YOURSELF

WARNING

Anti-freeze is poisonous and should be stored carefully marked containers out of the reach of children.

CAUTION

Do not substitute engine anti-freeze coolant for window washer solution. This may result in damage to the paint.

BATTERY

- Keep the battery surface clean and dry. Any corrosion should be washed off with a solution of baking soda and water.
- Make certain the terminal connections are clean and securely tightened.

- If the vehicle is not to be used for 30 days or longer, disconnect the (—) negative battery terminal cable to prevent discharge.

WARNING

- *Do not expose the battery to flames or electrical sparks. Hydrogen gas generated by battery action is explosive. Do not allow battery fluid to contact your skin, eyes, fabrics, or painted surfaces. After touching a battery or battery cap, do not touch or rub your eyes. Thoroughly wash your hands. If the acid contacts your eyes, skin or clothing, immediately flush with water for at least 15 minutes and seek medical attention.*
- *Do not operate the vehicle if the fluid in the battery is low. Low*

battery fluid can cause a higher load on the battery which can generate heat, reduce battery life, and in some cases lead to an explosion.

- *When working on or near a battery, always wear suitable eye protection and remove all jewelry.*
- *Battery posts, terminals and related accessories contain lead and lead compounds. Wash hands after handling.*
- *Keep the battery out of the reach of children.*

DO-IT-YOURSELF

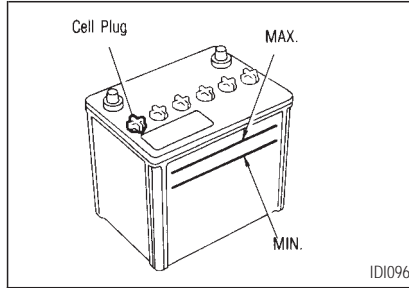

Check the fluid level in each cell (Remove the battery cover if it is necessary). It should be between the MAX. and MIN. lines.

If it is necessary to add fluid, add only distilled water to bring the level to the indicator in each filler opening. **Do not overfill.**

1. Remove the cell plugs.
2. Add distilled water up to the MAX. level.
3. Install the cell plugs.

Vehicle operated in high temperatures or under severe conditions require frequent checks of the battery fluid level.

JUMP STARTING

If jump starting is necessary, see "Jump starting" in the "6. In case of emergency" section. If the engine does not start by jump starting, the battery may have to be replaced. Contact your INFINITI retailer.

DRIVE BELTS

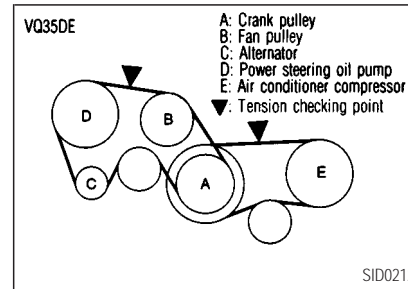

WARNING

Be sure the ignition key is in the OFF or LOCK position. The engine could rotate unexpectedly.

1. Visually inspect each belt for signs of unusual wear, cuts, fraying, oil adhesion or looseness. If the belt is in poor condition or loose, have it replaced or adjusted by your INFINITI retailer.
2. Have the belts checked regularly for condition and tension in accordance with the maintenance schedule in this manual.

DO-IT-YOURSELF

SPARK PLUGS

REPLACING SPARK PLUGS

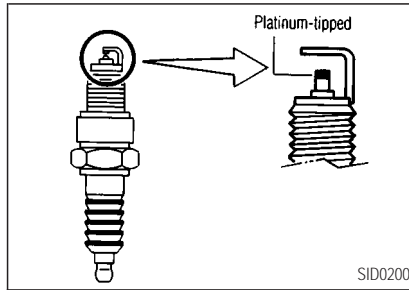

Platinum-tipped spark plugs

It is not necessary to replace the platinum-tipped spark plugs as frequently as the conventional type spark plugs since they will last much longer. Follow the maintenance schedule, but do not reuse them by cleaning or regapping.

If replacement is required, see your INFINITI retailer for servicing.

⚠ WARNING

Be sure the engine and ignition switch are off and that the parking brake is engaged securely.

⚠ CAUTION

Be sure to use the correct socket to remove the spark plugs. An incorrect socket can damage the spark plugs.

Always replace with recommended platinum-tipped spark plugs.

AIR CLEANER

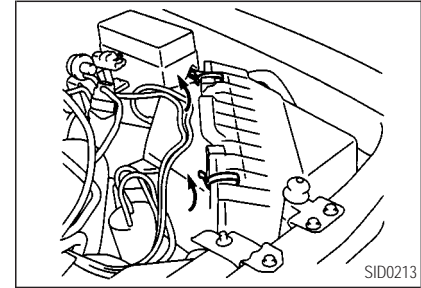

The filter element should not be cleaned and reused. Replace it according to the maintenance intervals. See "Periodic maintenance" in the "9. Maintenance" section for maintenance intervals. When replacing the filter, wipe the inside of the air cleaner housing and the cover with a damp cloth.

DO-IT-YOURSELF



WARNING

- *Operating the engine with the air cleaner removed can cause you or others to be burned. The air cleaner not only cleans the air, it stops flame if the engine backfires. If it is not there, and the engine backfires, you could be burned. Do not drive with the air cleaner removed, and be careful working on the engine with the air cleaner removed.*
- *Never pour fuel into the throttle body or attempt to start the engine with the air cleaner removed. Doing so could result in serious injury.*

WINDSHIELD WIPER BLADES

CLEANING

If your windshield is not clear after using the windshield washer, or if a wiper blade chatters when running, wax or other material may be on the blade or windshield.

Clean the outside of the windshield with a washer solution or a mild detergent. Your windshield is clean if beads do not form when rinsing with clear water.

Clean the blade by wiping it with a cloth soaked in a washer solution or a mild detergent. Then rinse the blade with clear water. If your windshield is still not clear after cleaning the blades and using the wiper, replace the blades.

DO-IT-YOURSELF

REPLACING

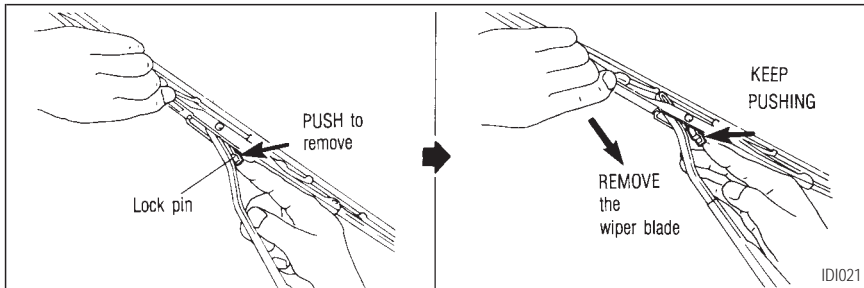

CAUTION

- After wiper blade replacement, return the wiper arm to its original position. Otherwise it may be damaged when the engine hood is opened.

Make sure the wiper blade contacts the glass, otherwise the arm may be damaged from wind pressure.

- Worn windshield wiper blades can damage the windshield and impair driven vision.

Replace the wiper blades if they are worn.

1. Pull the wiper arm.
2. Push the lock pin, then remove the wiper blade.
3. Insert the new wiper blade to the wiper arm until a click sounds.

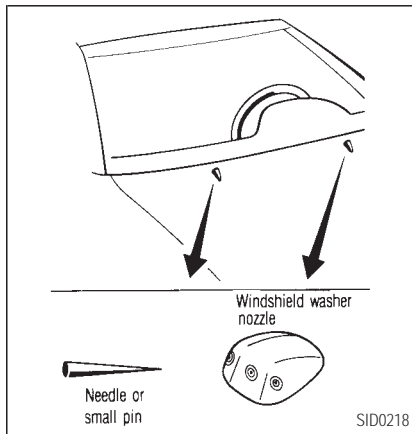

If you wax the surface of the hood, be careful not to let wax get into the washer

DO-IT-YOURSELF

nozzle. This may cause clogging or improper windshield washer operation. If wax gets into the nozzle, remove it with a needle or small pin.

PARKING BRAKE AND BRAKE PEDAL

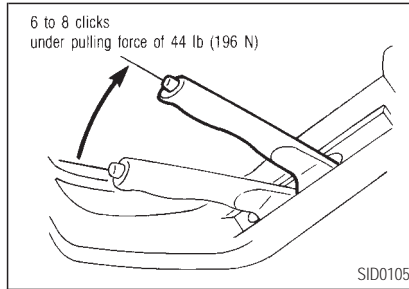

CHECKING PARKING BRAKE

Pull the parking brake lever up. If the number of clicks is out of the range as listed above, see your INFINITI retailer.

CHECKING BRAKE PEDAL

With the engine running, check the distance between the upper surface of the pedal and the metal floor. If it is out of the range shown above, see your INFINITI retailer.

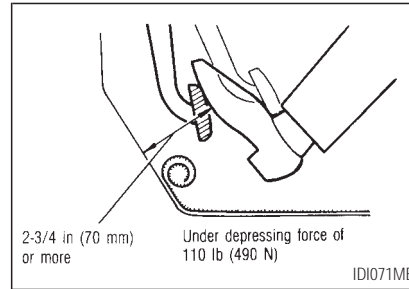

Self-adjusting brakes

Your vehicle is equipped with self-adjusting brakes.

The front and rear brakes self-adjust every time the brake pedal is applied.



WARNING

See your INFINITI retailer for a brake system check if the brake pedal height does not return to normal.

Brake pad wear indicators

The disc brake pads on your vehicle have audible wear indicators. When a brake pad requires replacement, it will make a high pitched scraping or screeching sound when the vehicle is in motion whether or not the brake pedal is depressed. Have the brakes checked as soon as possible if the wear indicator sound is heard.

Under some driving or climate conditions, occasional brake squeak, squeal or other noise may be heard. Occasional brake noise during light to moderate stops is normal and

DO-IT-YOURSELF

does not affect the function or performance of the brake system.

The rear drum brakes (if so equipped) do not have audible wear indicators. Should you ever hear an unusually loud noise from the rear drum brakes, have them inspected as soon as possible by your INFINITI retailer.

Proper brake inspection intervals should be followed. See “Periodic maintenance” in the “9. Maintenance” section for maintenance intervals.

BRAKE BOOSTER

Check the brake booster function as follows:

1. With the engine off, press and release the brake pedal several times. When brake pedal movement (distance of travel) remains the same from one pedal application to the next, continue on to the next step.
2. While depressing the brake pedal, start the

engine. The pedal height should drop a little.

3. With the brake pedal depressed, stop the engine. Keeping the pedal depressed for about 30 seconds, the pedal height should not change.
4. Run the engine for one minute without depressing the brake pedal, then turn it off. Depress the brake pedal several times. The pedal travel distance will decrease gradually with each depression as the vacuum is released from the booster.

If the brakes do not operate properly, see your INFINITI retailer.

FUSES



CAUTION

Never use a fuse of higher amperage

rating than that specified on the fuse box cover. This could damage the vehicle electrical system or cause a fire.

ENGINE COMPARTMENT

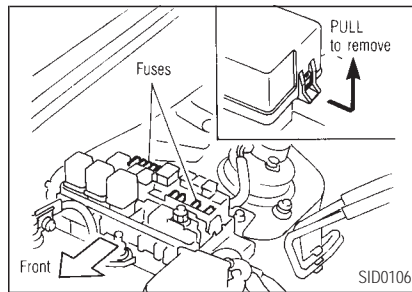

If any electrical equipment does not operate, check for an open fuse.

1. Be sure the ignition key and the headlight switch are OFF.

DO-IT-YOURSELF

2. Open the engine hood.
3. Remove the fuse box cover.
4. Remove the fuse with the fuse puller.
5. If the fuse is open, replace it with a new fuse.
6. If a new fuse opens again, have the electrical system checked and repaired by your INFINITI retailer.

and fuses are in good condition, check the fusible links. If any of these fusible links are melted, replace only with genuine parts. See your INFINITI retailer.

Fusible links

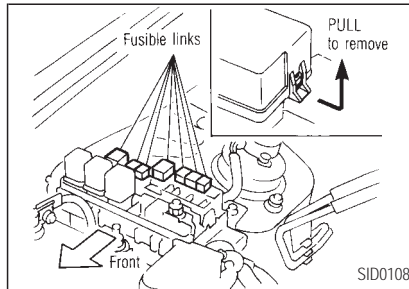

If any electrical equipment does not operate

DO-IT-YOURSELF

PASSENGER COMPARTMENT

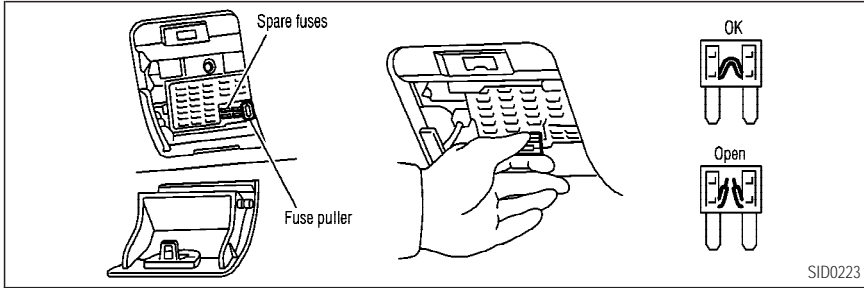

If any electrical equipment does not operate, check for an open fuse.

1. Be sure the ignition key and the headlight switch are OFF.
2. Pull to open the fuse box cover/coin tray.
3. Pull down the fuse box cover/coin tray to remove it.
4. Remove the fuse with the fuse puller.
5. If the fuse is open, replace it with a new fuse.
6. If a new fuse opens again, have the electrical system checked and repaired by your INFINITI retailer.

KEYFOB BATTERY REPLACEMENT

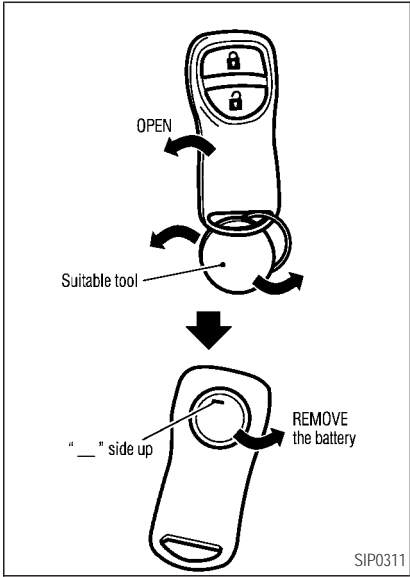

DO-IT-YOURSELF

Replace the battery as follows:

1. Open the lid using a suitable tool.
2. Replace the battery with a new one.
Recommended battery: Sanyo CR2025 or equivalent

Make sure that the ⊕ side faces the bottom case.

3. Close the lid securely.
4. Push the remote controller button two or three times to check its operation.

See your INFINITI retailer if you need any assistance for replacement.

If the battery is removed for any reason other than replacement, perform step 4 above.

- Be careful not to touch a circuit plate and a battery terminal.
- An improperly disposed battery can harm the environment. Always con-

firm local regulations for battery disposal.

- The keyfob is water-proof. However, if it does get wet, immediately wipe completely dry.
- When changing batteries, do not let dust or oil get on the controller.

FCC Notice:

Changes or modifications not expressly approved by the manufacturer compliance could void the user's authority to operate the equipment.

This device complies with Part 15 of the FCC Rules and RSS-210 of Industry Canada.

Operation is subject to the following two conditions: (1) This device may not cause harmful interference, and (2) this device must accept any interference received, including interference that may

cause undesired operation of the device.

LIGHTS

HEADLIGHTS

Replacing the xenon headlight bulb



WARNING



HIGH VOLTAGE

When xenon headlights are on, they produce a high voltage. To prevent an electric shock, never attempt to modify or disassemble. Always have your xenon headlights replaced at an authorized INFINITI retailer. For additional information, see "Headlight and turn signal switch" in the "2. Instruments and controls" section.

DO-IT-YOURSELF

EXTERIOR AND INTERIOR LIGHTS

Item	Wattage (W)	Bulb No.
Front turn signal light	21	7440
Front fog light (H3 type)	55	
Front parking light/Side marker light	See an authorized INFINITI retailer for assistance.	—
Rear combination light		
Turn signal	27	1156 NA
Stop/Tail	21/5	7443
Back-up	18	921
High mounted stop light	5	168
License plate light	3.8	194
Interior light	10	—
Vanity mirror light	1.4	—
Personal light	8	—

Replacement procedures

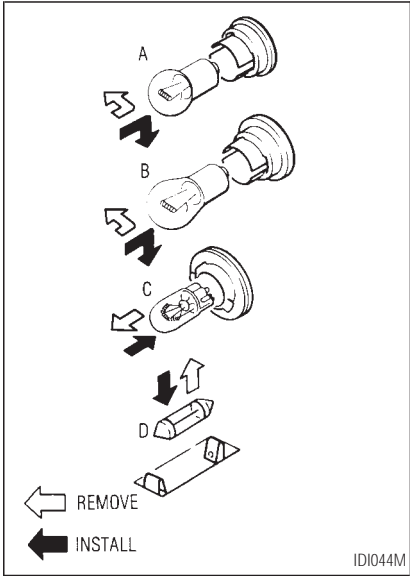

All other lights are either type A, B, C or D.

DO-IT-YOURSELF

When replacing a bulb, first remove the lens and/or cover.

DO-IT-YOURSELF

LIGHT LOCATION

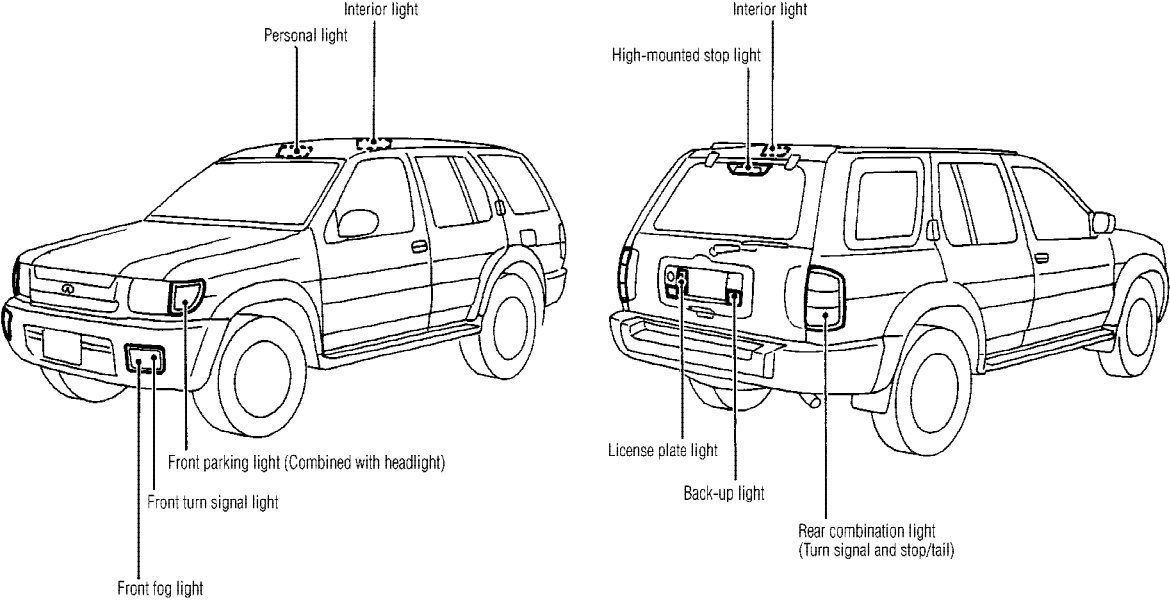

SID0214A

DO-IT-YOURSELF

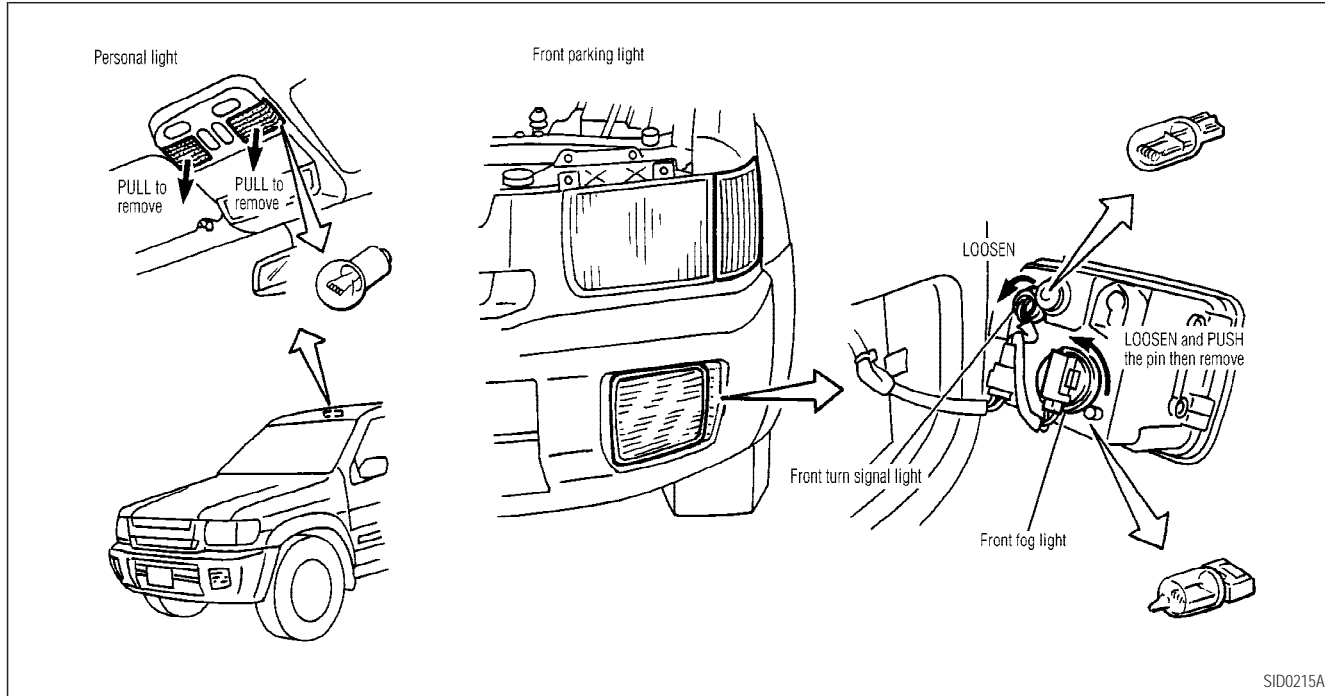

DO-IT-YOURSELF

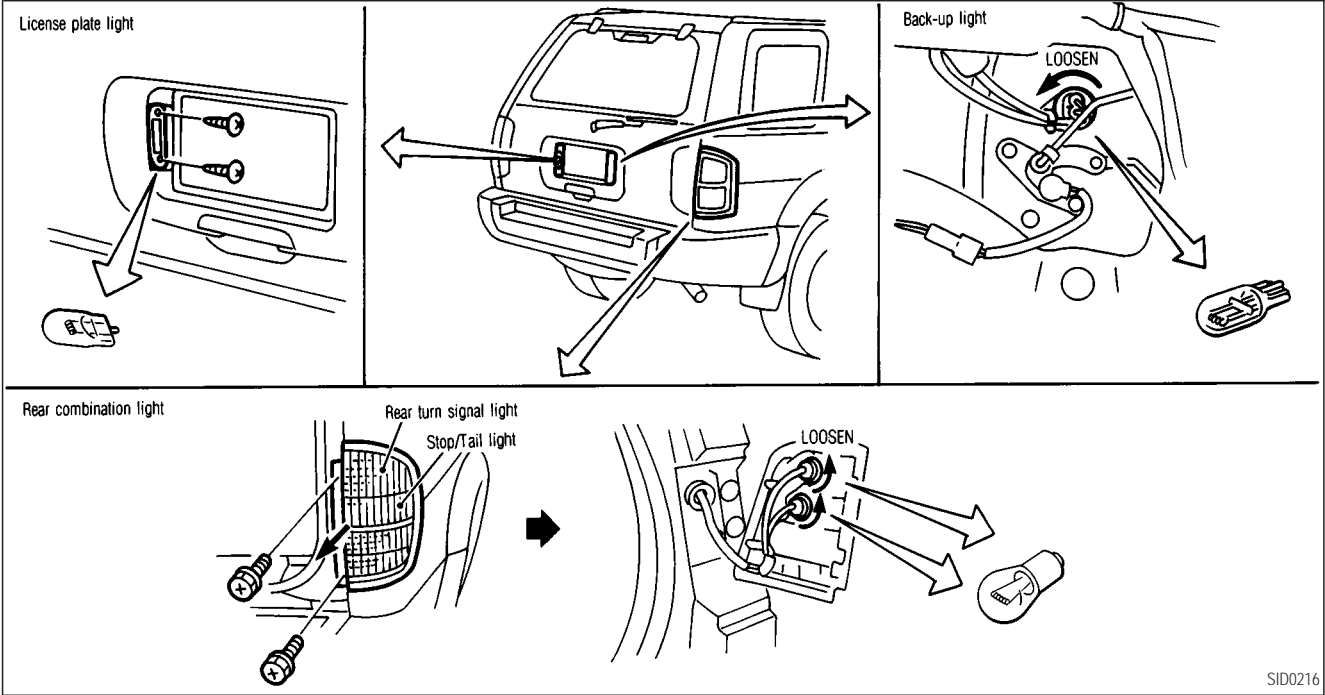

SID0216

DO-IT-YOURSELF

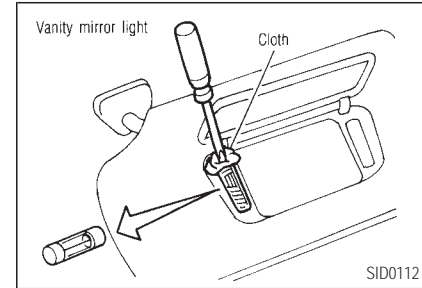
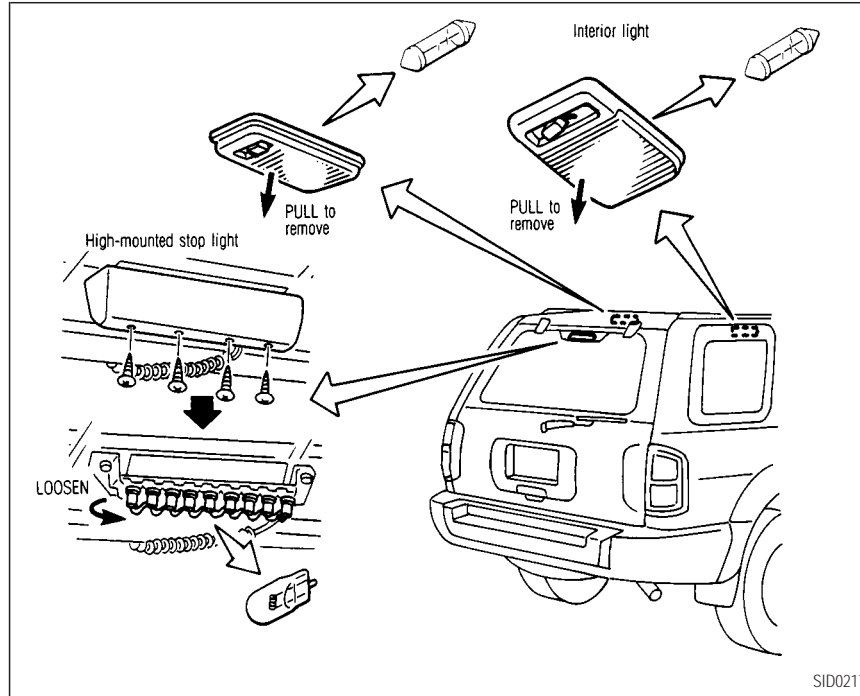

DO-IT-YOURSELF

WHEELS AND TIRES

If you have a flat tire, see “Flat tire” in the “6. In case of emergency” section.

TIRE PRESSURE

Maximum inflation pressure

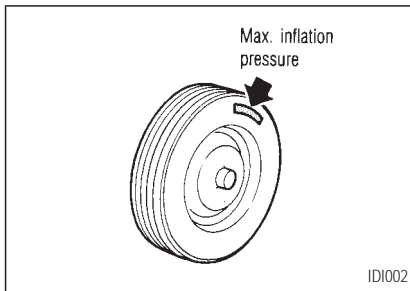

Do not exceed the maximum inflation pressures shown on the side wall of the tire.

Tire inflation pressure

Check the tire pressure (including spare) at least once a month and always prior to long

distance trips. Incorrect tire pressure may adversely affect tire life and vehicle handling. Tire pressure should be checked when the tires are COLD. Tires are considered COLD after the vehicle has been parked for three or more hours, or driven less than 1 mile (1.6 km) at moderate speeds. COLD tire pressures are shown on the tire placard affixed to the glove box lid.



WARNING

- *Improperly inflated tires can fail suddenly and cause an accident.*
 - *The vehicle weight capacity is indicated on the tire placard. Do not load your vehicle beyond this capacity. Overloading your vehicle may result in reduced tire life, unsafe operating conditions due to premature tire failure, or*
- unfavorable handling characteristics and could also lead to a serious accident. Loading beyond the specified capacity may also result in failure of other vehicle components.*
- *Before taking a long trip, or whenever you have loaded your vehicle heavily, use a tire pressure gauge to ensure that the tire pressure is at the specified level.*
 - *Do not drive your vehicle over 85 MPH (140 km/h) unless it is equipped with high speed capability tires. Driving faster than 85 MPH (140 km/h) may result in tire failure, loss of control and possible injury.*
 - *For additional information regarding tires, refer to “Important*

DO-IT-YOURSELF

Tire Safety Information” (US) or “Tire Safety Information” (Canada) in the Infiniti Warranty Information Booklet.

TYPES OF TIRES



WARNING

- *When changing or replacing tires, be sure all four tires are of the same type (i.e., summer, all season or snow) and construction. Your INFINITI retailer may be able to help you with information about tire type, size, speed rating and availability. Replacement tires may have a lower speed rating than the factory equipped tires, and may not match the potential*

maximum vehicle speed. Never exceed the maximum speed rating of the tire.

- *For additional information regarding tires, refer to “Important Tire Safety Information” (US) or “Tire Safety Information” (Canada) in the Infiniti Warranty Information Booklet.*

All season tires

INFINITI specifies all season tires on some models to provide good performance for use all year around, including snowy and icy road conditions. All season tires are identified by ALL SEASON and/or M&S on the tire sidewall. Snow tires have better snow traction than all season tires and may be more appropriate in some areas.

Snow tires

If snow tires are needed, it is necessary to select tires equivalent in size and load rating to the original equipment tires. If you do not, it can adversely affect the safety and handling of your vehicle.

If you install snow tires, they must also be the same size, brand, construction and tread pattern on all four wheels.

Generally, snow tires will have lower speed ratings than factory equipped tires and may not match the potential maximum vehicle speed. Never exceed the maximum speed rating of the tire.

If you operate your vehicle in snowy or icy conditions, INFINITI recommends the use of snow or all season tires on all four wheels.

For additional traction on icy roads, studded tires may be used. However, some provinces and states prohibit their use. Check local, state and provincial laws before installing

DO-IT-YOURSELF

studded tires. Skid and traction capabilities of studded snow tires, on wet or dry surfaces, may be poorer than that of non-studded snow tires.

TIRE CHAINS

Use of tire chains may be prohibited according to location. Check the local laws before installing tire chains. When installing tire chains, make sure they are of proper size for the tires on your vehicle and are installed according to the chain manufacturer's suggestions. **Use only SAE Class S chains.** Class "S" chains are used on vehicles with restricted tire to vehicle clearance. Vehicles that can use Class "S" chains are designed to meet the SAE standard minimum clearances between the tire and the closest vehicle suspension or body component required to accommodate the use of a winter traction device (tire chains or cables). The minimum clearances are determined using the factory equipped tire size. Other types may damage your vehicle. Use

chain tensioners when recommended by the tire chain manufacturer to ensure a tight fit. Loose end links of the tire chain must be secured or removed to prevent the possibility of whipping action damage to the fenders or underbody. If possible, avoid fully loading your vehicle when using tire chains. In addition, drive at a reduced speed. Otherwise, your vehicle may be damaged and/or vehicle handling and performance may be adversely affected.

Do not use the chains on dry roads.

Tire chains must be installed only on the rear wheels and not on the front wheels.

Do not drive with tire chains on paved roads which are clear of snow. Driving with chains in such conditions can cause damage to the various mechanisms of the vehicle due to some overstress. When driving on clear paved roads, be sure to change to 2WD.

CHANGING WHEELS AND TIRES

Tire rotation

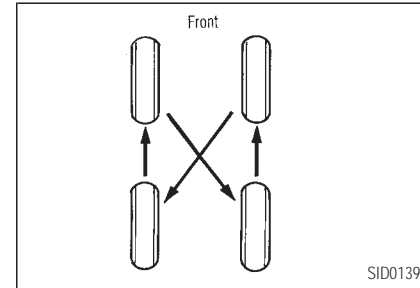

INFINITI recommends that tires be rotated approximately every 7,500 miles (12,000 km). However, the timing for tire rotation may vary according to your driving habits and road surface conditions.

**Wheel nut tightening torque:
98 ft-lb (133 N-m)**

See "Flat tire" in the "6. In case of emergency"

DO-IT-YOURSELF

section for tire replacing procedures.



WARNING

- After rotating the tires, adjust the tire pressure.
- Retighten the wheel nuts after the vehicle has been driven for 600 miles (1,000 km) (also in cases of a flat tire, etc.).
- For additional information regarding tires, refer to “Important Tire Safety Information” (US) or “Tire Safety Information” (Canada) in the Infiniti Warranty Information Booklet.

Tire wear and damage

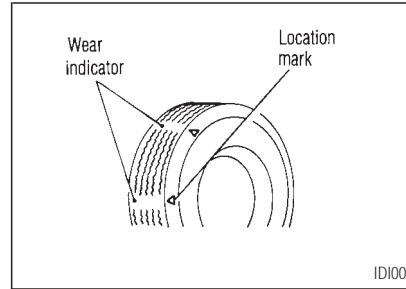

WARNING

- Tires should be inspected periodically for wear, cracking, bulging, or objects caught in the tread. If excessive wear, cracks, bulging, or deep cuts are found, the tire should be replaced.

- The original tires have a built-in tread wear indicator. When the wear indicator is visible, the tire should be replaced.
- For additional information regarding tires, refer to “Important Tire Safety Information” (US) or “Tire Safety Information” (Canada) in the Infiniti Warranty Information Booklet.

Replacing wheels and tires

When replacing a tire, use the same size and load carrying capacity as the original equipment tires. See “Specifications” in the “10. Technical and consumer information” section for tires and wheels.

If excessive tire wear is found, it is recommended that all four tires be replaced with tires of the same size, brand, construction and

tread pattern. The tire pressure and wheel alignment should also be checked and corrected as necessary. Contact your INFINITI retailer.



WARNING

- *The use of tires other than those recommended or the mixed use of tires of different brands, construction (bias, bias-belted or radial), or tread patterns can adversely affect the ride, braking, handling, ground clearance, body-to-tire clearance, tire chain clearance, speedometer calibration, headlight aim and bumper height. Some of these effects may lead to accidents and could result in serious personal injury.*

- *If the wheels are changed for any reason, always replace with wheels which have the same offset dimension. Wheels of a different offset could cause early tire wear, possibly degraded vehicle handling characteristics and/or interference with the brake discs/drums. Such interference can lead to decreased braking efficiency and/or early brake pad/shoe wear.*
- *Do not install a deformed wheel or tire even if it has been repaired. Such wheels or tires could have structural damage and could fail without warning.*
- *The use of retread tire is not recommended.*

DO-IT-YOURSELF

- *For additional information regarding tires, refer to "Important Tire Safety Information" (US) or "Tire Safety Information" (Canada) in the Infiniti Warranty Information Booklet.*



CAUTION

Always use tires of the same size, brand, construction (bias, bias-belted or radial), and tread pattern on all four wheels. A spare tire of the same size, brand, construction and tread pattern must also be used. Failure to do so may result in a circumference difference between tires on the front and rear axles which will cause excessive tire wear and may damage the transmission, transfer case and differential gears.

DO-IT-YOURSELF

Wheel balance

Unbalanced wheels may affect vehicle handling and tire life. Even with regular use, wheels can get out of balance. Therefore, they should be balanced as required.

Wheel balance service should be performed with the wheels off the vehicle. Spin balancing the driving wheels on the vehicle could lead to transmission damage. For additional information regarding tires, refer to “Important Tire Safety Information” (US) or “Tire Safety Information” (Canada) in the Infiniti Warranty Information Booklet.

Care of wheels

- Do not use abrasive cleaners when washing the wheels.
 - Inspect wheel rims regularly for dents or corrosion. Such damage may cause loss of pressure or poor seal at the tire bead.
 - INFINITI recommends that the road wheels be waxed to protect against road salt in areas where it is used during winter.
- Wash the wheels when washing the vehicle to maintain their appearance.
 - Clean the inner side of the wheels when the wheel is changed or the underside of the vehicle is washed.

9 MAINTENANCE

General maintenance 9-2
 Explanation of maintenance items 9-3
Periodic maintenance schedules 9-5

Schedule 1..... 9-5
Schedule 2..... 9-6
Explanation of maintenance items 9-11

MAINTENANCE

Your new INFINITI has been designed to have minimum maintenance requirements with longer service intervals to save you both time and money. However, some day-to-day and regular maintenance is essential to maintain your INFINITI's good mechanical condition, as well as its emission and engine performance.

It is the owner's responsibility to make sure that the specified maintenance, as well as general maintenance, is performed.

As the vehicle owner, you are the only one who can ensure that your vehicle receives the proper maintenance care. You are a vital link in the maintenance chain.

General maintenance :

General maintenance includes those items which should be checked during normal day-to-day operation of the vehicle. They are essential if your vehicle is to continue to operate properly. It is your responsibility to

perform these procedures regularly as prescribed.

These checks or inspections can be done by yourself, a qualified technician or, if you prefer, your INFINITI retailer.

Periodic maintenance :

The maintenance items listed in this part are required to be serviced at regular intervals.

However, under severe driving conditions, additional or more frequent maintenance will be required.

Where to go for service :

If maintenance service is required or your vehicle appears to malfunction, have the systems checked and serviced by an authorized INFINITI retailer.

INFINITI technicians are well-trained specialists and are kept up to date with the latest service information through technical bulletins, service tips, and in-dealership informa-

tion systems. They are completely qualified to work on INFINITI vehicles **before** work begins.

You can be confident that your INFINITI retailer's service department performs the best job to meet the maintenance requirements on your vehicle — in a reliable and economic way.

GENERAL MAINTENANCE

During the normal day-to-day operation of the vehicle, general maintenance should be performed regularly as prescribed in this section. If you detect any unusual sounds, vibrations or smell, be sure to check for the cause or have your INFINITI retailer do it promptly. In addition, you should notify your INFINITI retailer if you think that repairs are required.

When performing any checks or maintenance work, see "Maintenance precautions" in the "8. Do-it-yourself" section.

MAINTENANCE

EXPLANATION OF MAINTENANCE ITEMS

Additional information on the following items with * is found in the “8. Do-it-yourself” section.

Outside the vehicle

The maintenance items listed here should be performed from time to time, unless otherwise specified.

Tires* Check the pressure with a gauge at least once a month and always prior to long distance trips. If necessary, adjust the pressure in all tires, including the spare, to the pressure specified. Check carefully for damage, cuts or excessive wear.

Wheel nuts* When checking the tires, make sure no nuts are missing, and check for any loose nuts. Tighten if necessary.

Tire rotation* Tires should be rotated every 7,500 miles (12,000 km). However, the timing

for tire rotation may vary according to your driving habits and road surface conditions.

Wheel alignment and balance If the vehicle pulls to either side while driving on a straight and level road, or if you detect uneven or abnormal tire wear, there may be a need for wheel alignment.

If the steering wheel or seat vibrates at normal highway speeds, wheel balancing may be needed. For additional information regarding tires, refer to “Important Tire Safety Information” (US) or “Tire Safety Information” (Canada) in the Infiniti Warranty Information Booklet.

Windshield Clean the windshield on a regular basis. Check the windshield at least every six months for cracks or other damage. Have a damaged windshield repaired by a qualified repair facility.

Windshield wiper blades* Check for cracks or wear if they do not wipe properly.

Doors and engine hood Check that all doors and the engine hood, operate properly. Also ensure that all latches lock securely. Lubricate hinges and latches if necessary. Make sure that the secondary latch keeps the hood from opening when the primary latch is released.

When driving in areas using road salt or other corrosive materials, check lubrication frequently.

Inside the vehicle

The maintenance items listed here should be checked on a regular basis, such as when performing periodic maintenance, cleaning the vehicle, etc.

Lights* Clean the headlights on a regular basis. Make sure that the headlights, stop lights, tail lights, turn signal lights, and other lights are all operating properly and installed securely. Also check headlight aim.

Warning lights and chime Make sure that

MAINTENANCE

all warning lights and chime are operating properly.

Windshield wiper and washer* Check that the wipers and washer operate properly and that the wipers do not streak.

Windshield defroster Check that the air comes out of the defroster outlets properly and in sufficient quantity when operating the heater or air conditioner.

Steering wheel Check for changes in the steering conditions, such as excessive free play, hard steering or strange noises.

Seats Check seat position controls such as seat adjusters, seatback recliner, etc. to ensure they operate smoothly and that all latches lock securely in every position. Check that the head restraints move up and down smoothly and that the locks (if so equipped) hold securely in all latched positions.

Seat belts Check that all parts of the seat belt system (e.g. buckles, anchors, adjusters and

retractors) operate properly and smoothly, and are installed securely. Check the belt webbing for cuts, fraying, wear or damage.

Accelerator pedal Check the pedal for smooth operation and make sure the pedal does not catch or require uneven effort. Keep the floor mats away from the pedal.

Brakes Check that the brakes do not pull the vehicle to one side when applied.

Brake pedal and booster* Check the pedal for smooth operation and make sure it has the proper distance under it when depressed fully. Check the brake booster function. Be sure to keep the floor mats away from the pedal.

Parking brake* Check that the lever has the proper travel and confirm that your vehicle is held securely on a fairly steep hill with only the parking brake applied.

Automatic transmission P position mechanism On a fairly steep hill check that your vehicle is held securely with the selector

lever in the P position without applying any brakes.

Under the hood and vehicle

The maintenance items listed here should be checked periodically e.g. each time you check the engine oil or refuel.

Windshield washer fluid* Check that there is adequate fluid in the tank.

Engine coolant level* Check the coolant level when the engine is cold.

Radiator and hoses Check the front of the radiator and clean off any dirt, insects, leaves, etc., that may have accumulated. Make sure the hoses have no cracks, deformation, deterioration or loose connections.

Brake fluid level* Make sure that the brake fluid level is between the MAX and MIN lines on the reservoir.

Battery* Check the fluid level in each cell. It should be between the MAX and MIN lines.

MAINTENANCE

Vehicles operated in high temperatures or under severe conditions require frequent checks of the battery fluid level.

Engine drive belts* Make sure that no belt is frayed, worn, cracked or oily.

Engine oil level* Check the level after parking the vehicle on a level spot and turning off the engine. (Be sure to wait a few minutes to allow the oil to drain back into the sump.)

Power steering fluid level* and lines Check the level when the fluid is cold and the engine is turned off. Check the lines for proper attachment, leaks, cracks, etc.

Automatic transmission fluid level* Check the level after putting the selector lever in P (Park) with the engine idling.

Exhaust system Make sure there are no loose supports, cracks or holes. If the sound of the exhaust seems unusual or there is a smell of exhaust fumes, immediately locate the trouble and correct it. See "Precautions when

starting and driving" in the "5. Starting and driving" section for exhaust gas (carbon monoxide).

Underbody The underbody is frequently exposed to corrosive substances such as those used on icy roads or to control dust. It is very important to remove these substances, otherwise rust will form on the floor pan, frame, fuel lines and around the exhaust system. At the end of winter, the underbody should be thoroughly flushed with plain water, being careful to clean those areas where mud and dirt may accumulate. For additional information, see "Cleaning exterior" in the "7. Appearance and care" section.

Fluid leaks Check under the vehicle for fuel, oil, water or other fluid leaks after the vehicle has been parked for a while. Water dripping from the air conditioner after use is normal. If you should notice any leaks or if gasoline fumes are evident, check for the cause and have it corrected immediately.

PERIODIC MAINTENANCE SCHEDULES

To ensure smooth, trouble-free, safe and economical driving, INFINITI provides two different maintenance schedules that may be used, depending upon the conditions in which you usually drive. These schedules contain both distance and time intervals, up to 60,000 miles (96,000 km)/48 months. For most people, the odometer reading will indicate when service is needed. However, if you drive very little, your vehicle should be serviced at the regular time intervals shown in the schedule. **After 60,000 miles (96,000 km) or 48 months, continue periodic maintenance at the same mileage/time intervals.**

SCHEDULE 1

Follow Periodic Maintenance Schedule 1 if your driving habits frequently include one or more of the following driving conditions:

MAINTENANCE

- Repeated short trips of less than 5 miles (8 km).
- Repeated short trips of less than 10 miles (16 km) with outside temperatures remaining below freezing.
- Operating in hot weather in stop-and-go “rush hour” traffic.
- Extensive idling and/or low speed driving for long distances, such as police, taxi or door-to-door delivery use.
- Driving in dusty conditions.
- Driving on rough, muddy, or salt spread roads.
- Towing a trailer, using a camper or a car-top carrier.

Schedule 1 apply to your driving habits.

SCHEDULE 2

Follow Periodic Maintenance Schedule 2 if none of the driving conditions shown in

MAINTENANCE

Schedule 1

Abbreviations: R = Replace I = Inspect. Correct or replace if necessary.

[]: At the mileage intervals only

MAINTENANCE OPERATION		MAINTENANCE INTERVAL																
	Miles × 1,000	3.75	7.5	11.25	15	18.75	22.5	26.25	30	33.75	37.5	41.25	45	48.75	52.5	56.25	60	
Perform at number of miles, kilometers or months, whichever comes first.	(km × 1,000)	(6)	(12)	(18)	(24)	(30)	(36)	(42)	(48)	(54)	(60)	(66)	(72)	(78)	(84)	(90)	(96)	
	Months	3	6	9	12	15	18	21	24	27	30	33	36	39	42	45	48	
Emission control system maintenance																		
Drive belts																		I*
Air cleaner filter	See NOTE (1)																	[R]
EVAP vapor lines																		I*
Fuel lines																		I*
Fuel filter	See NOTE (2)*																	
Engine coolant	See NOTE (3)																	R*
Engine oil		R	R	R	R	R	R	R	R	R	R	R	R	R	R	R	R	R
Engine oil filter (Use Part No. 15208 31U00 or 15208 65F00 or equivalent.)		R	R	R	R	R	R	R	R	R	R	R	R	R	R	R	R	R
Spark plugs (PLATINUM-TIPPED type)		Replace every 105,000 miles (169,000 km)																
Intake & exhaust valve clearance*	See NOTE (4)																	

NOTE:

- (1) If operating mainly in dusty conditions, more frequent maintenance may be required.
- (2) When the filter becomes clogged, the vehicle speed cannot be increased as the driver wishes. In such an event, replace the filter.
- (3) After 60,000 miles (96,000 km) or 48 months, replace every 30,000 miles (48,000 km) or 24 months.
- (4) If valve noise increases, inspect valve clearance.

* Maintenance items and intervals with * are recommended by INFiniti for reliable vehicle operation. The owner need not perform such maintenance in order to maintain the emission warranty or manufacturer recall liability. Other maintenance items and intervals are required.

MAINTENANCE

Schedule 1

Abbreviations: R = Replace I = Inspect. Correct or replace if necessary. L = Lubricate.

MAINTENANCE OPERATION		MAINTENANCE INTERVAL																
Perform at number of miles, kilometers or months, whichever comes first.	Miles × 1,000	3.75	7.5	11.25	15	18.75	22.5	26.25	30	33.75	37.5	41.25	45	48.75	52.5	56.25	60	
	(km × 1,000)	(6)	(12)	(18)	(24)	(30)	(36)	(42)	(48)	(54)	(60)	(66)	(72)	(78)	(84)	(90)	(96)	
	Months	3	6	9	12	15	18	21	24	27	30	33	36	39	42	45	48	
Chassis and body maintenance																		
Brake lines & cables					I					I				I				I
Brake pads, rotors, drums & linings				I		I		I		I		I		I		I		I
Automatic transmission & all-mode 4WD transfer fluid & differential gear oil (exc. LSD)	See NOTE (1)				I				I				I					I
Limited-slip differential (LSD) gear oil	See NOTE (1)				I				R				I					R
Steering gear, linkage & transfer gear, axle & suspension parts			I		I		I		I		I		I		I		I	
Tire rotation	See NOTE (2)																	
Drive shaft boots and propeller shaft (4WD)			I		I		I		I		I		I		I		I	
Propeller shaft (4WD)	See NOTE (3)		L		L		L		L		L		L		L		L	
Front wheel bearing grease (2WD)									I				I					I
Front wheel bearing grease (4WD)	See NOTE (4)				I				R				I					R
Exhaust system			I				I		I		I		I		I		I	
In-cabin microfilter					R				R				R					R
Automatic Speed Control Device (ASCD) vacuum hoses					I				I				I					I

- NOTE: (1) If towing a trailer, using a camper or a car-top carrier, or driving on rough/muddy roads, change (not just inspect) fluid (A/T, all mode 4WD transfer)/oil at every 30,000 miles (48,000 km) or 24 months except for LSD, and change LSD gear oil at every 15,000 miles (24,000 km) or 12 months.
 (2) Refer to "Tire rotation" under the "General maintenance" heading earlier in this section.
 (3) The propeller shaft should be re-greased daily if it is immersed in water.
 (4) If operating frequently in water, replace grease every 3,750 miles (6,000 km) or 3 months.

MAINTENANCE

Schedule 2

Abbreviations: R = Replace I = Inspect. Correct or replace if necessary.

[]: At the mileage intervals only

MAINTENANCE OPERATION	MAINTENANCE INTERVAL								
	Miles × 1,000 (km × 1,000)	7.5 (12)	15 (24)	22.5 (36)	30 (48)	37.5 (60)	45 (72)	52.5 (84)	60 (96)
	Months	6	12	18	24	30	36	42	48
Emission control system maintenance									
Drive belts						I*			I*
Air cleaner filter						[R]			[R]
EVAP vapor lines						I*			I*
Fuel lines						I*			I*
Fuel filter	See NOTE (1)*								
Engine coolant	See NOTE (2)								R*
Engine oil		R	R	R	R	R	R	R	R
Engine oil filter (Use Part No. 15208 31U00 or 15208 65F00 equivalent.)		R	R	R	R	R	R	R	R
Spark plugs (PLATINUM-TIPPED type)									Replace every 105,000 miles (169,000 km)
Intake & exhaust valve clearance*	See NOTE (3)								

- NOTE: (1) When the filter becomes clogged, the vehicle speed cannot be increased as the driver wishes. In such an event, replace the filter.
 (2) After 60,000 miles (96,000 km) or 48 months, replace every 30,000 miles (48,000 km) or 24 months.
 (3) If valve noise increases, inspect valve clearance.

* Maintenance items and intervals with * are recommended by INFiniti for reliable vehicle operation. The owner need not perform such maintenance in order to maintain the emission warranty or manufacturer recall liability. Other maintenance items and intervals are required.

MAINTENANCE

Schedule 2

Abbreviations: R = Replace I = Inspect. Correct or replace if necessary. L = Lubricate.

MAINTENANCE OPERATION	MAINTENANCE INTERVAL								
	Miles × 1,000 (km × 1,000)	7.5 (12)	15 (24)	22.5 (36)	30 (48)	37.5 (60)	45 (72)	52.5 (84)	60 (96)
	Months	6	12	18	24	30	36	42	48
Chassis and body maintenance									
Brake lines & cables			I		I		I		I
Brake pads, rotors, drums & linings			I		I		I		I
Automatic transmission & all-mode 4WD transfer fluid & differential gear oil (exc. LSD)			I		I		I		I
Limited-slip differential (LSD) gear oil			I		R		I		R
Steering gear, linkage & transfer gear, axle & suspension parts					I				I
Tire rotation	See NOTE (1)								
Drive shaft boots and propeller shaft (4WD)			I		I		I		I
Propeller shaft (4WD)	See NOTE (2)		L		L		L		L
Front wheel bearing grease (2WD)					I				I
Front wheel bearing grease (4WD)			I		R		I		R
Exhaust system					I				I
In-cabin microfilter			R		R		R		R
Automatic Speed Control Device (ASCD) vacuum hoses			I		I		I		I

NOTE: (1) Refer to "Tire rotation" under the "General maintenance" heading earlier in this section.
 (2) The propeller shaft should be re-greased after being immersed in water.

MAINTENANCE

Maintenance for offroad driving (4x4 only)

Whenever you drive offroad through sand, mud or water as deep as the wheel hub, more frequent maintenance may be required of the following items:

- ▲ Brake pads and discs
- ▲ Brake lining and drums
- ▲ Brake lines and hoses
- ▲ Wheel bearing grease
- ▲ Differential, transmission and transfer oil
- ▲ Steering linkage
- ▲ Propeller shafts and front drive shafts
- ▲ Air cleaner filter

These items should be checked frequently to assure safe and proper operation of your vehicle.

EXPLANATION OF MAINTENANCE ITEMS

Additional information on the following items with * is found in the “8. Do-it-yourself” section.

Emission control system maintenance

Drive belts* Check drive belts for wear, fraying or cracking and also for proper tension. Replace the drive belts if found damaged.

Air cleaner filter Under normal driving conditions, the air cleaner filter should be replaced in accordance with the maintenance schedule. However, driving the vehicle in dusty areas may cause more rapid clogging of the element. Consequently, the element may have to be replaced more frequently.

EVAP vapor lines Check vapor lines and connections for failure or looseness. If leaks are found, replace them.

Fuel lines Check the fuel hoses, piping and connections for leaks, looseness or deterioration. Replace any parts if they are damaged.

Fuel filter When the filter becomes clogged, the vehicle speed cannot be increased as the driver wishes. In such an event, replace the filter.

Engine coolant* Drain and flush the cooling system.

Engine oil & oil filter* Under normal driving conditions, the engine oil and oil filter should be replaced in accordance with the maintenance schedule. However, under severe driving conditions, they may have to be replaced more frequently.

Spark plugs* Replace with new plugs having the correct heat range.

Intake & exhaust valve clearance Check the valve clearance if valve noise increases.

MAINTENANCE

Chassis and body maintenance

Brake lines & cables Check the brake lines and hoses (including brake booster vacuum hoses, connections & check valve) and parking brake cables for proper attachment, leaks, cracks, chafing, abrasion, deterioration, etc.

Brake pads, rotors, drums & linings

Check these and the other neighboring brake components for wear, deterioration and leaks. Under severe driving conditions, they may have to be inspected more frequently.

Automatic transmission oil & differential gear oil* Visually inspect for signs of leakage. Under severe driving conditions, the oil should be replaced at the specified interval.

Steering gear, linkage & transfer gear, axle and suspension parts

Check for damage, looseness and leakage of oil or grease. Under severe driving conditions, more frequent inspection should be performed.

Drive shaft boot and propeller shaft(s)

Check for damage, looseness and grease leakage under severe driving condition.

Propeller shaft Apply specified grease to the greasing points of propeller shafts in accordance with the maintenance schedule. In the case of driving in water, greasing should be performed immediately afterwards.

Front wheel bearing grease Check the wheel bearing for grease leakage around grease seals, axial end play and smooth turning (2WD). Check the wheel bearing grease condition or repack these in accordance with the maintenance schedule. In case of frequent driving in muddy water, the bearing grease inspection should be performed more frequently (4WD).

Exhaust system Visually check the exhaust pipes, muffler, and hangers for proper attachment, leaks, cracks, chafing, abrasion, deterioration, etc. Under severe driving conditions, inspection should be performed more frequently.

In-cabin microfilter Under normal conditions, the in-cabin microfilter should be replaced in accordance with the maintenance schedule. However, in some situations, the microfilter may clog more rapidly (depending on the air conditioner's working environment). If this happens, the air flow may decrease, or the windows may fog up easily when the air conditioner is in use, the microfilter should be replaced immediately at your INFINITI retailer.

Automatic Speed Control (ASC) vacuum hoses Check vacuum hose (between ASCD actuator and ASCD pump) for breakage, cracks or fracture.

10 TECHNICAL AND CONSUMER INFORMATION

Capacities and recommended fuel/lubricants	10-2	Vehicle identification number (Chassis number)	10-12
Fuel recommendation	10-3	Engine serial number	10-12
Engine oil and oil filter recommendation	10-5	F.M.V.S.S. certification label	10-12
Recommended SAE viscosity number	10-7	Emission control information label	10-13
Air conditioner system refrigerant and lubricant recommendations	10-8	Tire placard	10-13
Specifications	10-9	Air conditioner specification label	10-13
Engine	10-9	Vehicle loading information	10-14
Wheels and tires	10-10	Terms	10-14
Dimensions and weights	10-10	Determining vehicle payload capacity	10-14
When traveling or registering your vehicle in another country	10-11	Securing the load	10-15
Vehicle identification	10-11	Loading tips	10-15
Vehicle identification number (VIN) plate	10-11	Payload weight capacity	10-16
		Measurement of weights	10-16
		Towing a trailer	10-16
		Maximum load limits	10-17
		Towing load/specification chart	10-18
		Towing safety	10-18

Uniform tire quality grading	10-21	Owner's manual/service manual order	
Emission control system warranty	10-22	information	10-25
Reporting safety defects (US only)	10-23	In the event of a collision.....	10-26
Readiness for inspection/maintenance (I/M)			
test (US only)	10-23		

TECHNICAL AND CONSUMER INFORMATION

CAPACITIES AND RECOMMENDED FUEL/LUBRICANTS

The following are approximate capacities. The actual refill capacities may be a little different. When refilling, follow the procedure instructed in the "8. Do-it-yourself" section to determine the proper refill capacity.

	Capacity (Approximate)			Recommended specifications	
	US measure	Imp measure	Liter		
Fuel	20-7/8 gal	17-3/8 gal	79	Unleaded gasoline with an octane rating of at least 87 AKI (RON 91)*1	
Engine oil (Drain and refill)*9				<ul style="list-style-type: none"> • API Certification Mark*2, *3 • API grade SG/SH, Energy Conserving I & II or API grade SJ or SL, Energy Conserving*2, *3 • ILSAC grade GF-I GF-II & GF-II*2, *3 	
	With oil filter change	5-1/4 qt	4-3/8 qt		5.0
	Without oil filter change	5-1/8 qt	4-1/4 qt		4.8
Cooling system					
	With reservoir	9-3/4 qt	8-1/8 qt	9.2	Genuine NISSAN anti-freeze coolant or equivalent
Differential gear oil	—	—	—	Standard differential gear: API GL-5*3 Limited-slip differential (LSD) gear: Use only LSD gear oil API GL-5 and SAE 80W-90*6 approved for Nissan LSD*7.	
Automatic transmission fluid				Nissan Matic "D" (Continental U.S. and Alaska) or Canada NISSAN Automatic Transmission Fluid.*5	
Power steering fluid				Genuine Nissan PSF II or equivalent*10	
All-mode 4WD transfer fluid				Nissan Matic "D" (Continental U.S. and Alaska) or Canada NISSAN Automatic Transmission Fluid.*8	
Brake fluid				Genuine Brake Fluid*4 or equivalent DOT 3 (U.S. FMVSS No. 116)	
Propeller shaft grease	—	—	—	NLGI No. 2 (Molybdenum disulphide lithium soap base)	
Multi-purpose grease	—	—	—	NLGI No. 2 (Lithium soap base)	
Air conditioning system refrigerant	—	—	—	HFC-134a (R-134a)	
Air conditioning system lubricants				Nissan A/C System Oil Type S or equivalent	

*1: See later in this section for fuel recommendation.

*2: See later in this section for engine oil and oil filter recommendation.

*3: See later in this section for recommended SAE viscosity number.

*4: Available in mainland U.S. through your INFINITI retailer.

*5: DEXRONTM III/MERCONTM or equivalent may also be used. Outside the continental U.S. and Alaska contact an authorized INFINITI retailer for more information regarding suitable fluids, including recommended brand(s) of DEXRONTM III/MERCONTM Automatic Transmission Fluid.

*6: SAE 90 is acceptable in temperatures above 0°F (-18°C).

*7: Contact your INFINITI retailer for a list of approved oils.

*8: Outside the continental U.S. and Alaska contact an authorized INFINITI retailer for more information regarding suitable fluids, including recommended brand(s) of DEXRONTM III/MERCONTM Automatic Transmission Fluid.

*9: See "Changing engine oil" in the "8. Do-it-yourself" section for further details.

*10: Genuine Nissan PSF, Canada NISSAN Automatic Transmission Fluid, DEXRONTM III/MERCONTM or equivalent ATF may also be used.

TECHNICAL AND CONSUMER INFORMATION

FUEL RECOMMENDATION

Use unleaded regular gasoline with an octane rating of at least 87 AKI (Anti-Knock Index) number (Research octane number 91).

For improved vehicle performance, INFINITI recommends the use of unleaded premium gasoline with an octane rating of at least 91 AKI number (Research octane number 96).



CAUTION

Using a fuel other than that specified could adversely affect the emission control devices and systems, and could also affect warranty coverage.

Under no circumstances should a leaded gasoline be used, since this will damage the three way catalyst.

Reformulated gasoline

Some fuel suppliers are now producing reformulated gasolines. These gasolines are specially designed to reduce vehicle emissions. INFINITI supports efforts towards cleaner air and suggests that you use reformulated gasoline when available.

Gasoline containing oxygenates

Some fuel suppliers sell gasoline containing oxygenates such as ethanol, MTBE and methanol with or without advertising their presence. INFINITI does not recommend the use of fuels of which the oxygenate content and the fuel compatibility for your INFINITI cannot be readily determined. If in doubt, ask your service station manager.

If you use oxygenate-blend gasoline, please take the following precautions as the usage of such fuels may cause vehicle performance problems and/or fuel system damage.

- The fuel should be unleaded and

have an octane rating no lower than that recommended for unleaded gasoline.

- If an oxygenate-blend, excepting a methanol blend, is used, it should contain no more than 10% oxygenate. (MTBE may, however, be added up to 15%.)
- If a methanol blend is used, it should contain no more than 5% methanol (methyl alcohol, wood alcohol). It should also contain a suitable amount of appropriate cosolvents and corrosion inhibitors. If not properly formulated with appropriate cosolvents and corrosion inhibitors, such methanol blends may cause fuel system damage and/or vehicle performance problems. At this time, sufficient data is not available to ensure that all methanol blends are suitable for use in INFINITI vehicles.

TECHNICAL AND CONSUMER INFORMATION

If any undesirable driveability problems such as engine stalling and hard hot starting are experienced after using oxygenate-blend fuels, immediately change to a non-oxygenate fuel or a fuel with a low blend of MTBE.

Take care not to spill gasoline during refueling. Gasoline containing oxygenates can cause paint damage.

Aftermarket fuel additives

INFINITI does not recommend the use of any fuel additives (i.e. fuel injector cleaner, octane booster, intake valve deposit removers, etc.) which are sold commercially. Many of these additives intended for gum, varnish or deposit removal may contain active solvent or similar ingredients that can be harmful to the fuel system and engine.

Octane rating tips

In most parts of North America, you should use unleaded gasoline with an octane rating of at least 91 AKI (Anti-Knock Index) number.

However, you may use unleaded gasoline with an octane rating as low as 85 AKI (Anti-Knock Index) number in these high altitude areas [over 4,000 ft (1,219 m)] such as: Colorado, Montana, New Mexico, Utah, Wyoming, northeastern Nevada, southern Idaho, western South Dakota, western Nebraska, and that part of Texas which is directly south of New Mexico.

Using unleaded gasoline with an octane rating lower than stated above can cause persistent, heavy “spark knock”. (“Spark knock” is a metallic rapping noise.) If severe, this can lead to engine damage. If you detect a persistent heavy spark knock even when using gasoline of the stated octane rating, or if you hear steady spark knock while holding a steady speed on level roads, have your dealer correct the condition. Failure to correct the condition is misuse of the ve-

hicle, for which INFINITI is not responsible.

Incorrect ignition timing will result in knocking, after-run or overheating. This in turn may cause excessive fuel consumption or damage to the engine. If any of the above symptoms are encountered, have your vehicle checked at an INFINITI retailer or other competent service facility.

However, now and then you may notice light spark knock for a short time while accelerating or driving up hills. This is no cause for concern, because you get the greatest fuel benefit when there is light spark knock for a short time under heavy engine load.

TECHNICAL AND CONSUMER INFORMATION

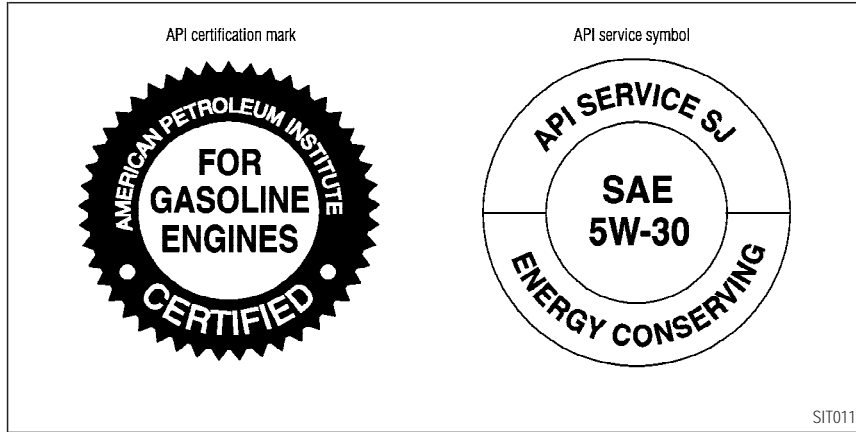

ENGINE OIL AND OIL FILTER RECOMMENDATION

Selecting the correct oil

It is essential to choose the correct quality, and viscosity oil to ensure satisfactory engine life and performance. Nissan recommends the use of a low friction oil (energy conserving

oil) in order to improve fuel economy and conserve energy. Oils which do not have the specified quality label should not be used as they could cause engine damage.

Only those engine oils with the American Petroleum Institute (API) CERTIFICATION MARK on the front of the container should be

used. This type of oil supersedes the existing API SG, SH or SJ and Energy Conserving II categories.

If you cannot find engine oil with the API CERTIFICATION MARK, use an API grade SG/SH, Energy Conserving I & II or API grade SJ or SL, Energy Conserving oil. An oil with a single designation SG or SH, or in combination with other categories (for example, SG/CC or SG/CD) may also be used if one with the API CERTIFICATION MARK cannot be found. An ILSAC grade GF-I, II & III oil can also be used.

INFINITI does not recommend synthetic type oils but recommends mineral based oils. These oils must however, meet the API quality and SAE viscosity ratings specified for your vehicle.

Oil additives

INFINITI does not recommend the use of oil additives. The use of an oil additive is not

TECHNICAL AND CONSUMER INFORMATION

necessary when the proper oil type is used and maintenance intervals are followed.

Oil which may contain foreign matter or has been previously used should not be used.

Oil viscosity

The engine oil viscosity or thickness changes with temperature. Because of this, it is important that the engine oil viscosity be selected based on the temperatures at which the vehicle will be operated before the next oil change. The chart "Recommended SAE viscosity number" shows the recommended oil viscosities for the expected ambient temperatures. Choosing an oil viscosity other than that recommended could cause serious engine damage.

Selecting the correct oil filter

Your new vehicle is equipped with a high-quality genuine Nissan oil filter. When replacing, use the genuine oil filter or its equivalent for the reason described in "change intervals".

Change intervals

The oil and oil filter change intervals for your engine are based on the use of the specified quality oils and filters. Oil and filter other than the specified quality, or oil and filter change intervals longer than recommended could reduce engine life. Damage to engines caused by improper maintenance or use of incorrect oil and filter quality and/or viscosity is not covered by the new INFINITI vehicle warranties.

Your engine was filled with a high quality engine oil when it was built. You do not have to change the oil before the first recommended change interval. Oil and filter change intervals depend upon how you use your vehicle. Operation under the following conditions may require more frequent oil and filter changes.

- repeated short distance driving at cold outside temperatures,
- driving in dusty conditions,

- extensive idling,
- towing a trailer.

TECHNICAL AND CONSUMER INFORMATION

RECOMMENDED SAE VISCOSITY NUMBER

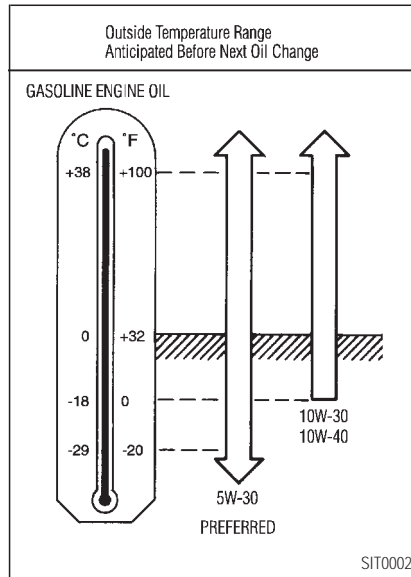

- SAE 5W-30 viscosity oil is preferred for all temperatures. SAE 10W-30, 10W-40 viscosity oil may be used if the ambient temperature is above 0°F (-18°C).

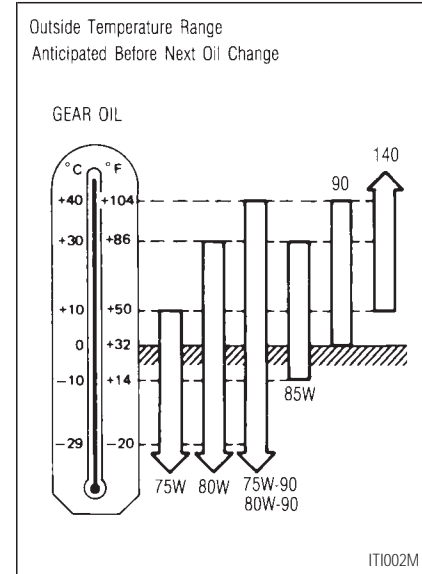

- 80W-90 for differential is preferable.

TECHNICAL AND CONSUMER INFORMATION

AIR CONDITIONING SYSTEM REFRIGERANT AND LUBRI- CANT RECOMMENDATIONS

The air conditioning in your INFINITI vehicle must be charged with the refrigerant HFC-134a (R-134a) and the lubricant, Nissan A/C system oil Type S or the exact equivalents.



CAUTION

The use of any other refrigerant or lubricant will cause severe damage to the air conditioning system and will require the replacement of all air conditioning system components.

The refrigerant HFC-134a (R-134a) in your INFINITI vehicle will not harm the earth's ozone layer. Although this refrigerant does not affect the earth's atmosphere, certain govern-

mental regulations require the recovery and recycling of any refrigerant during automotive air conditioning system service. Your INFINITI retailer has the trained technicians and equipment needed to recover and recycle your air conditioning system refrigerant.

Contact your INFINITI retailer when servicing your air conditioning system.

TECHNICAL AND CONSUMER INFORMATION

SPECIFICATIONS

ENGINE

Model		VQ35DE
Type		Gasoline, 4-cycle
Cylinder arrangement		6-cylinder, V-slanted at 60°
Bore × Stroke	in (mm)	3.760 × 3.205 (95.5 × 81.4)
Displacement	cu in (cm ³)	213.45 (3,498)
Firing order		1-2-3-4-5-6*1
Idle speed	rpm	
Ignition timing (BTDC)	degree/rpm	See the "Emission control label" on the underside of the hood.
CO percentage at idle speed	[No air] %	
Spark plug		
Standard		PLFR5A-11
Service		PLFR4A-11
Option		PLFR6A-11
Spark plug gap	in (mm)	0.043 (1.1)
Camshaft operation		Timing chain
Alternator belt size		
Width × Length	in (mm)	0.8409 × 46.26 (21.36 × 1,175)

The spark ignition system of this vehicle meets all requirements of the Canadian Interference-Causing Equipment Regulations.

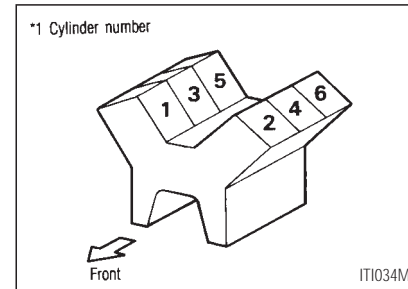

TECHNICAL AND CONSUMER INFORMATION

WHEELS AND TIRES

Road wheel	Aluminum	17 x 8JJ
	Offset	in (mm) 0.79 (20)
Tire size	Conventional	P245/65R17 105S
	Spare	Conventional

DIMENSIONS AND WEIGHTS

Overall length	in (mm)	183.1 (4,650)
Overall width	in (mm)	72.4 (1,840)
Overall height	in (mm)	68.1 (1,730), 70.7 (1,795)*
Front tread	in (mm)	60.6 (1,540)
Rear tread	in (mm)	60.8 (1,545)
Wheelbase	in (mm)	106.3 (2,700)
Gross vehicle weight rating	lb (kg)	
Gross axle weight rating		See the "F.M.V.S.S. certification label" on the driver's side lock pillar.
Front	lb (kg)	
Rear	lb (kg)	

TECHNICAL AND CONSUMER INFORMATION

WHEN TRAVELING OR REGISTERING YOUR VEHICLE IN ANOTHER COUNTRY

If you plan to travel in another country, you should first find out if the fuel available is suitable for your vehicle's engine.

Using fuel with too low an octane rating may cause engine damage. All gasoline vehicles must be operated with unleaded gasoline. Therefore, avoid taking your vehicle to areas where appropriate fuel is not available.

When transferring the registration of your vehicle to another country, state, province or district, it may be necessary to modify the vehicle to meet local laws and regulations.

The laws and regulations for motor vehicle emission control and safety standards vary according to the country, state, province or

district; therefore, vehicle specifications may differ.

When any vehicle is to be taken into another country, state, province or district and registered, its modifications, transportation, and registration are the responsibility of the user. INFINITI is not responsible for any inconvenience that may result.

VEHICLE IDENTIFICATION NUMBER (VIN) PLATE

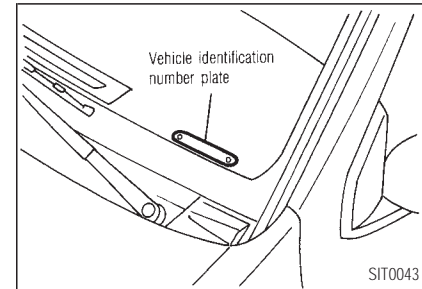

The vehicle identification number plate is attached as shown. This number is the identification for your vehicle and is used in the vehicle registration.

TECHNICAL AND CONSUMER INFORMATION

VEHICLE IDENTIFICATION NUMBER (Chassis number)

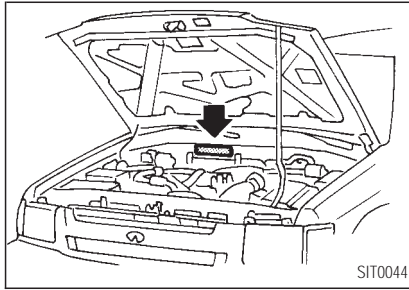

The number is stamped as shown.

ENGINE SERIAL NUMBER

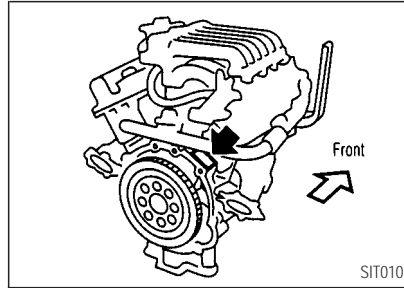

The number is stamped on the engine as shown.

F.M.V.S.S. CERTIFICATION LABEL

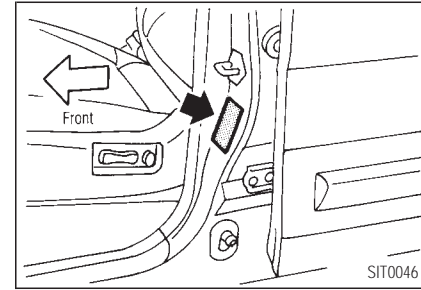

The Federal Motor Vehicle Safety Standard (F.M.V.S.S.) certification label is affixed as shown. This label contains valuable vehicle information, such as: Gross Vehicle Weight Ratings (GVWR), Gross Axle Weight Rating (GAWR), month and year of manufacture, Vehicle Identification Number, (VIN), etc. Review it carefully.

TECHNICAL AND CONSUMER INFORMATION

EMISSION CONTROL INFORMATION LABEL

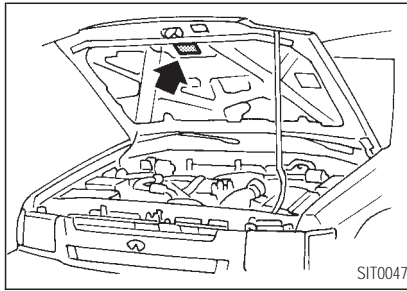

The emission control information label is attached as shown.

TIRE PLACARD

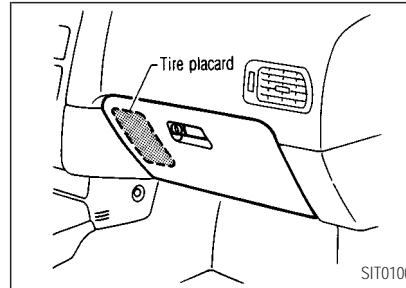

The cold tire pressure is shown on the tire placard affixed to the glove box lid.

AIR CONDITIONER SPECIFICATION LABEL

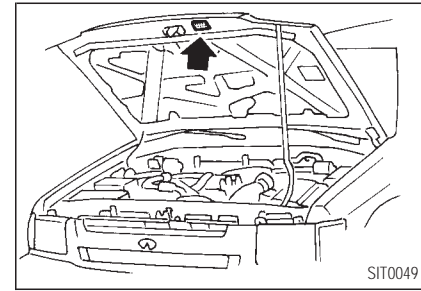

The air conditioner specification label is attached as shown.

TECHNICAL AND CONSUMER INFORMATION

VEHICLE LOADING INFORMATION



WARNING

- *It is extremely dangerous to ride in a cargo area inside of a vehicle. In a collision, people riding in these areas are more likely to be seriously injured or killed.*
- *Do not allow people to ride in any area of your vehicle that is not equipped with seats and seat belts.*
- *Be sure everyone in your vehicle is in a seat and using a seat belt properly.*

TERMS

It is important to familiarize yourself with the

following terms before loading your vehicle:

- **Curb Weight** (actual weight of your vehicle) - vehicle weight including: standard and optional equipment, fluids, emergency tools, and spare tire assembly. This weight **does not** include passengers and cargo.
- **GVW** (Gross Vehicle Weight) - curb weight plus the combined weight of passengers and cargo.
- **GVWR** (Gross Vehicle Weight Rating) - maximum total weight (load) limit specified for the vehicle.
- **GAWR** (Gross Axle Weight Rating) - maximum weight (load) limit specified for the front or rear axle.

DETERMINING VEHICLE PAYLOAD CAPACITY

The payload capacity of this vehicle is determined by weight, not by available cargo space. For example, a luggage rack, bike

carrier, cartop carrier or similar equipment does not increase payload carrying capacity of your vehicle.

To determine vehicle payload capacity:

Vehicle weight can be determined by using a commercial-grade scale, found at places such as a truck stop, gravel quarry, grain elevator, or a scrap metal recycling facility.

- 1) Determine the curb weight of your vehicle.
- 2) Compare the curb weight amount to the GVWR specified for your vehicle to determine how much more weight your vehicle can carry.
- 3) After loading (cargo and passengers), reweigh your vehicle to determine if either GVWR or GAWR for your vehicle is exceeded. If GVWR is exceeded, remove cargo as necessary. If either the front or rear GAWR is exceeded, shift the load or remove cargo as necessary.

TECHNICAL AND CONSUMER INFORMATION

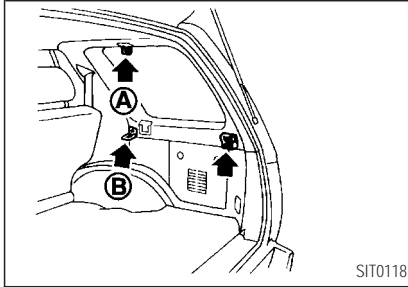

SECURING THE LOAD

There are tie down hooks located in the cargo area. The tie down hooks can be used to secure cargo with ropes or other types of straps.

Do not apply a total load of more than 22 lbs. (10 kg) to a single hook when securing cargo.

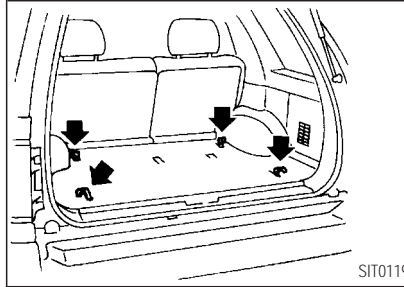

LOADING TIPS

- The GVW must not exceed GVWR or GAWR as specified on the FMVSS Certification Label located on the driver's door center pillar.
- Do not load the front and rear axle to the GAWR. Doing so will exceed the GVWR.
- Loads should be spread out, and cargo should be properly secured. Large or heavy objects should be placed toward the

front of the cargo area to help prevent sliding or shifting.



WARNING

- *Properly secure all cargo to help prevent it from sliding or shifting. Do not place cargo higher than the seatbacks. In a sudden stop or collision, unsecured cargo could cause personal injury.*
- *Do not load your vehicle any heavier than the GVWR or the maximum front and rear GAWRs. If you do, parts on your vehicle can break, or it can change the way your vehicle handles. This could result in loss of control and cause personal injury.*

TECHNICAL AND CONSUMER INFORMATION

PAYLOAD WEIGHT CAPACITY

The payload weight capacity is the maximum total weight of passengers, optional equipment (air conditioning, trailer hitch, etc.) and cargo that your vehicle is designed to carry.

Before driving a loaded vehicle, confirm that you do not exceed the Gross Vehicle Weight Rating (GVWR) or the Gross Axle Weight Rating (GAWR) for your vehicle. See "Vehicle loading information" earlier in this section for details.

Also check tires for proper inflation pressures. See the tire placard affixed to the glove box lid.

Payload Weight Capacity Unit: lb (kg)		
VQ35DE		
	2WD	4WD
	Automatic and Manual Transmission	Automatic and Manual Transmission
	XE, SE, LE	
US	940 (427)	920 (418)
Canada	—	880 (400)

MEASUREMENT OF WEIGHTS

Secure loose items to prevent weight shifts that could affect the balance of your vehicle. When the vehicle is loaded, drive to a scale and weight the front and the rear wheels separately to determine axle loads. Individual axle loads should not exceed either of the gross axle weight ratings (GAWR). The total of the axle loads should not exceed the gross vehicle weight rating (GVWR). These ratings are given on the vehicle certification label that is located on the driver's door lock pillar. If weight ratings are exceeded, move or remove

items to bring all weights below the ratings.



CAUTION

Overloading can shorten the life of your vehicle. Failures caused by overloading are not covered by your warranty.

TOWING A TRAILER

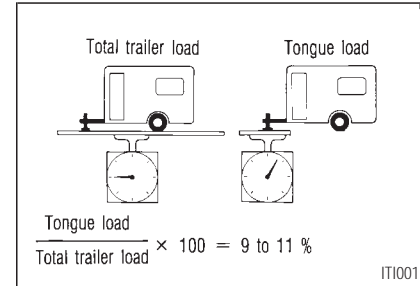

Your new vehicle was designed to be used

TECHNICAL AND CONSUMER INFORMATION

primarily to carry passengers and cargo. Remember that towing a trailer will place additional loads on your vehicle's engine, drive train, steering, braking and other systems.

Information on trailer towing and the special equipment required should be obtained from a professional trailer dealer/installer.

MAXIMUM LOAD LIMITS

Maximum trailer loads

Never allow the total trailer load to exceed the value specified in the following Towing Load/Specification Chart. The total trailer load equals trailer weight plus its cargo weight.

- When towing a trailer load of 1,000 lb (454 kg) or more, trailers with a brake system MUST be used.

The maximum GCWR (Gross Combined Weight Rating) should not exceed the value

specified in the following Towing Load Specification Chart.

The GCWR equals the combined weight of the towing vehicle (including passengers and cargo) plus the total trailer load. Towing loads greater than these or using improper towing equipment could adversely affect vehicle handling, braking and performance.

The ability of your vehicle to tow a trailer is not only related to the maximum trailer loads, but also the places you plan to tow. Tow weights appropriate for level highway driving may have to be reduced on very steep grades or in low traction situations (for example, on slippery boat ramps).



WARNING

Vehicle damage and/or personal injury resulting from improper towing

procedures is not covered by INFINITI warranties. An Infiniti Trailer Towing Guide (U.S. only) containing information on trailer towing ability and the special equipment required may be obtained from an authorized INFINITI retailer.

Tongue load

Keep the tongue load between 9 to 11% of the total trailer load within the maximum tongue load limits shown in the following Towing Load/Specifications Chart. If the tongue load becomes excessive, rearrange cargo to allow for proper tongue load.

TECHNICAL AND CONSUMER INFORMATION

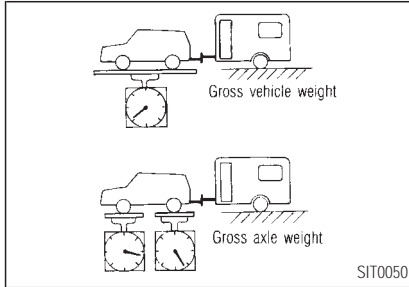

Maximum gross vehicle weight/maximum gross axle weight

The gross vehicle weight of the towing vehicle must not exceed the gross vehicle weight rating (GVWR) shown on the F.M.V.S.S. certification label. The gross vehicle weight equals the combined weight of the unloaded vehicle, passengers, luggage, hitch, trailer tongue load and any other optional equipment. In addition, front or rear gross axle weight must not exceed the gross axle weight

rating (GAWR) shown on the F.M.V.S.S. certification label.

TOWING LOAD/ SPECIFICATION CHART		Unit: lb (kg)
WEIGHT	MODEL	QX-4 VQ35DE (6-Cyl.)
		A/T
MAXIMUM TRAILER WEIGHT*1		5,000 (2,268)
MAXIMUM TONGUE LOAD		500 (227)
GROSS COMBINED WEIGHT RATING		9,500 (4,308)
RECOMMENDED EQUIPMENT*2		Sway Control Device (SCD)

*1: All towing above 1,000 lb (454 kg) requires the use of trailer brakes. INFINITI recommends the use of a tandem axle trailer whenever towing above 3,000 lb (1,361 kg).

*2: A sway control device is recommended for all towing above 2,000 lb (907 kg). Sway control devices are not offered by INFINITI. See a professional trailer/hitch outlet for a properly designed sway control device for your trailer.

TOWING SAFETY

Trailer hitch

Choose a proper hitch for your vehicle and trailer. A genuine INFINITI trailer hitch is available from your INFINITI retailer (US only). Make sure the trailer hitch is securely attached to the vehicle, to help avoid personal injury or property damage due to sway caused by crosswinds, rough road surfaces or passing trucks.

TECHNICAL AND CONSUMER INFORMATION



CAUTION

- *Special hitches which include frame reinforcements are required for towing above 2,000 lb (907 kg). Suitable Genuine INFINITI hitches for pickup truck and sport utility vehicles are available at an authorized INFINITI retailer.*
- *Do not use axle-mounted hitches.*
- *Do not modify the vehicle exhaust system, brake system, etc. to install a trailer hitch.*
- *After the hitch is removed, seal the bolt holes to prevent exhaust fumes, water or dust from entering the passenger compartment.*

- *Regularly check all hitch mounting bolts are securely mounted.*
- *To reduce the possibility of additional damage if your vehicle is struck from the rear, where practical, remove the hitch and/or receiver when not in use. After the hitch is removed, seal the bolt holes to prevent exhaust fumes, water or dust from entering the passenger compartment.*

Tire pressures

- When towing a trailer, inflate the vehicle tires to the recommended cold tire pressure indicated on the tire placard (located on the inside of the glove box lid).
- Trailer tire condition, size, load rating and proper inflation pressure should be in accordance with the trailer and tire manu-

facturers' specifications.

Safety chain

Always use a suitable chain between your vehicle and the trailer. The chain should be crossed and should be attached to the hitch, not to the vehicle bumper or axle. Be sure to leave enough slack in the chain to permit turning corners.

Trailer lights

Trailer lights should comply with Federal and/or local regulations.

When wiring the vehicle for towing, connect the stop and tail light pickup into the vehicle electrical circuit at a point between the sensor and stop light switch or light switch.

Trailer brakes

If your trailer is equipped with a braking system, make sure it conforms to Federal

TECHNICAL AND CONSUMER INFORMATION

and/or local regulations and that it is properly installed.



WARNING

Never connect a trailer brake system directly to the vehicle brake system.

Pre-towing tips

- Be certain your vehicle maintains a level position when a loaded or unloaded trailer is hitched. Do not drive the vehicle if it has an abnormal nose-up or nose-down condition; check for improper tongue load, overload, worn suspension or other possible causes of either condition.
- Always secure items in the trailer to prevent load shifts while driving.
- Be certain your rear view mirrors conform to all federal, state or local regulations. If not, install any mirrors required for towing

before driving the vehicle.

Trailer towing tips

In order to gain skill and an understanding of the vehicle's behavior, you should practice turning, stopping and backing up in an area which is free from traffic. Steering stability, and braking performance will be somewhat different than under normal driving conditions.

- Always secure items in the trailer to prevent load shift while driving.
- Avoid abrupt starts, acceleration or stops.
- Avoid sharp turns or lane changes.
- Always drive your vehicle at a moderate speed.
- Always block the wheels on both vehicle and trailer when parking. Parking on a slope is not recommended; however, if you must do so, and if your vehicle is equipped with automatic transmission,

first block the wheels and apply the parking brake, and then move the transmission selector lever into the P position. If you move the selector lever to the P position before blocking the wheels and applying the parking brake, transmission damage could occur.

- When going down a hill, shift into a lower gear and use the engine braking effect. When ascending a long grade, downshift the transmission to a lower gear and reduce speed to reduce chances of engine overloading and/or overheating.

However, for long steep grades, do not stay in 1st or 2nd gear when driving above 35 MPH (56 km/h).

- If the engine coolant rises to an extremely high temperature when the air conditioning system is on, turn off the air conditioner. Coolant heat can be additionally vented by opening the windows, switching the fan

TECHNICAL AND CONSUMER INFORMATION

control to high and setting the temperature control to the HOT position.

- Trailer towing requires more fuel than normal circumstances.
- Avoid towing a trailer for the first 500 miles (800 km).
- Have your vehicle serviced more often than at intervals specified in the recommended maintenance schedule.
- When making a turn, your trailer wheels will be closer to the inside of the turn than your vehicle wheels. To compensate for this, make a larger than normal turning radius during the turn.
- Crosswinds and rough roads will adversely affect vehicle/trailer handling, possibly causing vehicle sway. When being passed by larger vehicles, be prepared for possible changes in crosswinds that could affect vehicle handling. If swaying does occur, firmly grip the steering wheel, steer

straight ahead, and immediately (but gradually) reduce vehicle speed. This combination will help stabilize the vehicle. Never increase speed.

- Be careful when passing other vehicles. Passing while towing a trailer requires considerably more distance than normal passing. Remember the length of the trailer must also pass the other vehicle before you can safely change lanes.
- To maintain engine braking efficiency and electrical charging performance, do not use overdrive (automatic transmission).
- Avoid holding the brake pedal down too long or too frequently. This could cause the brakes to overheat, resulting in reduced braking efficiency.

When towing a trailer, change fluid in the transmission more frequently.

See the “9. Maintenance” section.

UNIFORM TIRE QUALITY GRADING

DOT (Department of Transportation) Quality Grades: All passenger car tires must conform to Federal Safety Requirements in addition to these grades.

Quality grades can be found where applicable on the tire sidewall between tread shoulder and maximum section width. For example:

Treadwear 200 Traction AA Temperature A

Treadwear

Treadwear grade is a comparative rating based on tire wear rate when tested under controlled conditions on specified government test courses. For example, a tire graded 150 would wear one and a half (1-1/2) times as well on the government course as a tire graded 100. However, relative tire performance depends on actual driving conditions, and may vary significantly due to variations in

TECHNICAL AND CONSUMER INFORMATION

driving habits, service practices and differences in road characteristics and climate.

Traction AA, A, B and C

The traction grades from highest to lowest are AA, A, B, and C. Those grades represent the tire's ability to stop on wet pavement as measured under controlled conditions on specified government test surfaces of asphalt and concrete. A tire marked C may have poor traction performance.



WARNING

The traction grade assigned to your vehicle tires is based on straight-ahead braking traction tests, and does not include acceleration, cornering, hydroplaning, or peak traction characteristics.

Temperature A, B and C

Temperature grades are A (the highest), B, and C. They represent a tire's resistance to heat build-up, and its ability to dissipate heat when tested under controlled conditions on a specified indoor laboratory test wheel. Sustained high temperature can cause tire material to degenerate, reducing tire life. Excessive temperatures can lead to sudden tire failure. Grade C corresponds to a performance level which all passenger car tires must meet under the Federal Motor Vehicle Safety Standard No. 109. Grades A and B represent higher levels of performance on laboratory test wheels than the minimum required by law.



WARNING

The temperature grade for this tire is established for a tire that is properly

inflated and not overloaded. Excessive speed, under inflation, or excessive loading, either separately or in combination, can cause heat build-up and possible tire failure.

EMISSION CONTROL SYSTEM WARRANTY

Your INFINITI is covered by the following emission warranties.

For US

- 1) Emission Defects Warranty
- 2) Emissions Performance Warranty
(See Warranty Information Booklet for details.)

For Canada

Emission Control System Warranty

Details of these warranties may be found with

TECHNICAL AND CONSUMER INFORMATION

other vehicle warranties in your Warranty Information Booklet [Warranty and Roadside Assistance Information (Canada)] that comes with your INFINITI. If you did not receive a Warranty Information Booklet [Warranty and Roadside Assistance Information (Canada)], or it has become lost, you may obtain a replacement by writing to or calling:

- INFINITI Division
Nissan North America, Inc.
Consumer Affairs Department
P.O. Box 191, Gardena, CA 90248-0191
- Nissan Canada Inc.
5290 Orbitor Drive
Mississauga, Ontario,
L4W 4Z5
Tel. No. 1-800-387-0122
- INFINITI Division
Nissan Motor Corporation in Hawaii, Ltd.
Consumer Affairs Department
2880 Kilihau Street

Honolulu, Hawaii 96819
Tel. No. 1-808-836-0888

REPORTING SAFETY DEFECTS (US only)

If you believe that your vehicle has a defect which could cause a crash or could cause injury or death, you should immediately inform the National Highway Traffic Safety Administration (NHTSA) in addition to notifying INFINITI.

If NHTSA receives similar complaints, it may open an investigation, and if it finds that a safety defect exists in a group of vehicles, it may order a recall and remedy campaign. However, NHTSA cannot become involved in individual problems between you, your dealer, or INFINITI.

To contact NHTSA, you may call the Auto Safety Hotline toll-free at 1-888-327-4236. You may also write to: NHTSA, U.S. Department of Transportation,

Washington, D.C. 20590. You can also obtain other information about motor vehicle safety from the Hotline.

You may notify INFINITI by contacting our Consumer Affairs Department, toll-free, at 1-800-662-6200.
In Hawaii call 1-808-836-0888

READINESS FOR INSPECTION/ MAINTENANCE (I/M) TEST (US only)

Due to legal requirements in some states/ areas, your vehicle may be required to be in what is called the ready condition for an Inspection/Maintenance (I/M) test of the emission control system.

The vehicle is set to the ready condition when it is driven through certain driving patterns. Usually, the ready condition can be obtained by ordinary usage of the vehicle.

TECHNICAL AND CONSUMER INFORMATION

If a powertrain system component is repaired or the battery is disconnected, the vehicle may be reset to a not ready condition. Before taking the I/M test, drive the vehicle through the following pattern to set the vehicle to the ready condition.



WARNING

Always drive the vehicle in a safe and prudent manner according to traffic conditions, and obey all traffic laws.

1. Start the engine. Allow the engine to idle until the engine coolant temperature gauge needle points between the C and H (normal operating temperature).
2. Accelerate the vehicle to 55 MPH (88 km/h), then quickly release the accelerator pedal completely and maintain it released for at least 6 seconds.
3. Quickly depress the accelerator pedal for a moment, then drive the vehicle at a speed of 53 to 60 MPH (86 to 96 km/h) for at least 5 minutes.
4. Stop the vehicle. Leave the engine running.
5. Accelerate the vehicle to 35 MPH (55 km/h) and maintain the speed for 20 seconds.
6. Repeat steps 4 and 5 at least three times.
7. Accelerate the vehicle to 55 MPH (88 km/h) and maintain the speed for at least 3 minutes.
8. Stop the vehicle. Place the transmission gear shift lever in the "P" or "N" position.
9. Rev the engine up between 2,500 and 3,500 rpm and hold it there for 3 consecutive minutes, then release the accelerator pedal completely.
10. Wait 5 seconds with the engine at idle.
11. Rev the engine up between 2,000 and 3,000 rpm and maintain that speed for 5 consecutive minutes.
12. Turn the engine off.
13. Repeat steps 1 through 8 at least one more time.

If step 1 through 7 is interrupted, repeat the preceding step. Any safe driving mode is acceptable between steps. Do not stop the engine until step 7 is completed.

Dynamometer testing for Inspection/Maintenance (I/M) test (US only)

Due to legal requirements in some states/areas, your vehicle may be tested for emissions on a dynamometer. The 4WD shift switch **MUST** be in the 2WD position for I/M testing on a two wheel dynamometer.

TECHNICAL AND CONSUMER INFORMATION



WARNING

- *If the 4WD shift switch is not in the 2WD mode during the dynamometer I/M testing, the vehicle could come off the dynamometer and cause serious personal injury and/or body damage to the vehicle.*
- *Serious damage will occur to the 4WD system if the 4WD shift switch is not in the 2WD mode.*

OWNER'S MANUAL/SERVICE MANUAL ORDER INFORMATION

A genuine INFINITI Service Manual is the best source of service and repair information for your vehicle. Filled with wiring diagrams, illustrations and step-by-step diagnostic and

adjustment procedures, this manual is the same one used by the factory trained technicians working at authorized INFINITI retailers. Also available are genuine INFINITI Owner's Manuals, and genuine INFINITI Service and Owner's Manuals for older INFINITI models.

In the USA:

For current pricing and availability of genuine **INFINITI Service Manuals** for the 2000 model year and later, contact:

Tweddle Litho Company
1-800-639-8841
www.nissan-techinfo.com

For current pricing and availability of genuine **INFINITI Service Manuals** for the 1999 model year and prior, see an authorized INFINITI retailer, or contact:

DDS Distribution Services, Ltd.
20770 Westwood Road
Strongsville, OH 44136

1-800-247-5321

For current pricing and availability of genuine **INFINITI Owner's Manuals** for the 2001 model year and prior, see an authorized INFINITI retailer, or contact:

DDS Distribution Services, Ltd.
20770 Westwood Road
Strongsville, OH 44136
1-800-247-5321

In Canada:

To purchase a copy of a genuine INFINITI Service Manual or Owner's Manual please contact your nearest INFINITI retailer. For the phone number and location of an INFINITI retailer in your area call the INFINITI Satisfaction Center at 1-800-361-4792 and a bilingual INFINITI representative will assist you.

Also available are genuine INFINITI Service and Owner's Manuals for older INFINITI models.

TECHNICAL AND CONSUMER INFORMATION

IN THE EVENT OF A COLLISION

Unfortunately, accidents do occur. In this unlikely event, there is some important information you should know. Many insurance companies routinely authorize the use of non-genuine collision parts in order to cut costs, among other reasons.

Insist on the use of Genuine INFINITI Collision Parts!

If you want your vehicle to be restored using parts made to INFINITI's original exacting specifications — if you want to help it to last and hold its resale value, the solution is simple. **Tell your insurance agent and your repair shop to only use Genuine INFINITI Collision Parts.** INFINITI does not warrant non-INFINITI parts, nor does INFINITI's warranty apply to damage caused by a non-genuine part.

Using Genuine INFINITI Parts can help protect your personal safety, preserve your warranty

protection and maintain the resale value of your vehicle. And if your vehicle was leased, using Genuine INFINITI Parts may prevent or limit unnecessary excess wear and tear expenses at the end of your lease.

INFINITI designs its hoods with crumple zones to minimize the risk that the hood will penetrate the windshield of your vehicle in an accident. Non-genuine (imitation) parts may not provide such built in safeguards. Also, non-genuine parts often show premature wear, rust and corrosion.

Why should you take a chance?

In over 40 states, the law says you must be advised if non-genuine parts are used to repair your vehicle. And some states/provinces have enacted laws that restrict insurance companies from authorizing the use of non-genuine collision parts during the new vehicle warranty. These laws help

protect you, so you can take action to protect yourself.

It's your right!

11 Index

A

ABS (Anti-lock brake system)	5-45
Air bag system	
Front (See supplemental front air bag system)...	1-15
Side (See supplemental side air bag system).....	1-17
Air bag warning labels	1-21
Air bag warning light.....	1-21, 2-14
Air cleaner housing filter.....	8-15
Air conditioner	
Air conditioner operation.....	4-3
Air conditioner service.....	4-3, 4-6
Air conditioner specification label.....	10-13
Air conditioning system refrigerant and lubricant recommendations	4-6, 10-8
Heater and air conditioner (automatic).....	4-3
Alcohol, drugs and driving.....	5-5
Anchor point locations	
Top tether strap.....	1-46
Antenna	4-24
Anti-lock Brake System (ABS).....	5-45
Anti-lock brake warning light.....	2-10
Appearance care	
Exterior appearance care.....	7-2
Interior appearance care.....	7-4
Armrest.....	1-8
Ashtray (See cigarette lighter and ashtray).....	2-31
ATP warning light.....	2-11
Audible reminders.....	2-17
Audio operation precautions.....	4-8
Audio system	4-6
Steering wheel audio controls	4-23
Autochanger	
Compact Disc (CD).....	4-20
Automatic	
Automatic transmission fluid (ATF).....	8-10
Drive positioner.....	3-18
Driving with automatic transmission.....	5-11
Seat positioner, seat	3-18
Transmission park warning light.....	2-11
Transmission selector lever lock release	5-14
Avoiding collision and rollover	5-4

B

Back door.....	3-11
Battery	8-13
Battery saver system	2-25
Battery replacement, (See remote keyless entry system).....	3-9

Before starting the engine	5-9
Belts (See drive belts).....	8-14
Brake	
Anti-lock brake system (ABS).....	5-45
Brake booster.....	8-19
Brake fluid.....	8-12
Brake pedal	8-18
Brake pedal check.....	8-18
Brake system.....	5-45
Parking brake check.....	5-16, 8-18
Parking brake operation.....	5-16
Warning light	2-12
Break-in schedule.....	5-34
Bulb check/instrument panel	2-10
Bulb replacement	8-22

C

Capacities and recommended fuel/lubricants.....	10-2
Car phone or CB radio.....	4-25
Cargo (See vehicle loading information)	2-38
Cargo net	2-38
Cassette player (See audio system).....	4-13, 4-19
Catalytic converter, Three way catalyst.....	5-3
CD care and cleaning.....	4-22

INDEX

Child restraints	1-34
Installation on front passenger seat	1-47
Installation on rear seat outboard positions.....	1-39
Installation on rear seat center position.....	1-36
Precautions on child restraints.....	1-34
Top tether strap anchor point locations.....	1-46
With top tether strap.....	1-45
Child safety.....	1-26
Child safety rear door lock.....	3-4
Chimes, Audible reminders.....	2-17
Cigarette lighter and ashtray.....	2-31
Circuit breaker, Fusible link.....	8-20
Cleaning exterior and interior.....	7-2, 7-4
Clock.....	2-30
Coin box.....	2-32
Cold weather driving.....	5-47
Compact Disc (CD) changer operation.....	4-20
Compact Disc (CD) player (See audio system).....	4-9
Compass display.....	2-7
Console box.....	2-34
Controls	
Heater and air conditioner controls (automatic)....	4-3
Steering wheel audio controls.....	4-23
Coolant	
Capacities and recommended fuel/ lubricants....	10-2

Changing engine coolant.....	8-6
Checking engine coolant level.....	8-5
Corrosion protection.....	7-5
Cover, Tonneau cover.....	2-38
Cruise control.....	5-17
Cruise control, Intelligent cruise control system.....	5-19
Cup holders.....	2-33

D

Daytime running light system.....	2-27
Defogger switch, Glass hatch and outside mirror defogger switch.....	2-22
Determining vehicle payload capacity.....	10-14
Dimensions and weights.....	10-10
Door open warning light.....	2-13
Drinking alcohol/drugs and driving.....	5-5
Drive belts.....	8-14
Drive positioner, Automatic.....	3-18
Driving	
Cold weather driving.....	5-47
Driving with automatic transmission.....	5-11
On-pavement and offroad driving.....	5-4
Precautions when starting and driving.....	5-2

Safety precautions.....	5-5
-------------------------	-----

E

Economy, Fuel.....	5-34
Electric sunroof.....	2-42
Emission control information label.....	10-13
Emission control system warranty.....	10-22
Engine	
Before starting the engine.....	5-9
Capacities and recommended fuel/lubricants.....	10-2
Changing engine coolant.....	8-6
Changing engine oil.....	8-8
Changing engine oil filter.....	8-9
Checking engine coolant level.....	8-5
Checking engine oil level.....	8-7
Coolant temperature gauge.....	2-5
Engine block heater.....	5-50
Engine compartment check locations.....	8-4
Engine cooling system.....	8-5
Engine oil.....	8-7
Engine oil and oil filter recommendation.....	10-5
Engine oil viscosity.....	10-6
Engine serial number.....	10-12
Engine specifications.....	10-9

INDEX

If your vehicle overheats.....	6-10
Starting the engine.....	5-10
Exhaust gas (Carbon monoxide).....	5-2

F

4WD shift switch operations.....	5-39
F.M.V.S.S. certification label.....	10-12
Filter, Air cleaner housing filter.....	8-15
Flashers (See hazard warning flasher switch).....	2-28
Flat tire.....	6-2
Floor mat cleaning.....	7-4
Fluid	
Automatic transmission fluid (ATF).....	8-10
Brake fluid.....	8-12
Capacities and recommended fuel/lubricants.....	10-2
Engine coolant.....	8-5
Engine oil.....	8-7
Power steering fluid.....	8-11
Window washer fluid.....	8-12
FM-AM radio with cassette player.....	4-10
FM-AM radio with cassette player and Compact Disc (CD) player/changer.....	4-16
Fog light switch.....	2-27
Four wheel drive (4WD).....	5-35

Front air bag system (See supplemental restraint system).....	1-15
Front window operating with key.....	3-3
Front fog light switch.....	2-27
Front power seat adjustment.....	1-3
Fuel	
Capacities and recommended fuel/lubricants.....	10-2
filler cap.....	3-13
filler lid.....	3-13
Fuel economy.....	5-34
Fuel octane rating.....	10-3
Fuel recommendation.....	10-3
Gauge.....	2-5
Fuses.....	8-19
Fusible links.....	8-20

G

Garage door opener, HomeLink® Universal Transceiver.....	2-47
Gas cap.....	3-13
Gauge.....	2-3
Engine coolant temperature gauge.....	2-5
Fuel gauge.....	2-5
Odometer.....	2-4

Speedometer.....	2-4
Tachometer.....	2-4
General maintenance.....	9-2
Glass hatch and outside mirror defogger switch.....	2-22
Glass hatch lock.....	3-12
Glass hatch opener.....	3-12
Glove box.....	2-34
Glove box lock.....	2-34

H

Hazard warning flasher switch.....	2-28
Head restraints.....	1-7
Headlights	
Bulb replacement.....	8-22
Headlight switch.....	2-24
Xenon headlights.....	2-23
Heated seats.....	2-29
Heater	
Engine coolant heater.....	5-50
Heater and air conditioner (automatic).....	4-3
HomeLink® Universal Transceiver.....	2-47
Hood, release.....	3-10
Hook, Luggage hook.....	2-36
Horn.....	2-28

INDEX

How to stop alarm, Vehicle security..... 2-19

I

Ignition switch 5-8
 Automatic transmission models..... 5-11
 Key positions 5-9
Immobilizer system 2-19
In-cabin microfilter 4-6
Indicator lights 2-15
Infiniti Vehicle Immobilizer System, Engine start 5-9
Inside mirror 3-17
Inspection/maintenance (I/M) test 10-23
Instrument panel 2-2
Intelligent cruise control (ICC) system 5-19
Interior light replacement..... 8-23
Interior lights 2-45
ISOFIX child restraint 1-44

J

Jump starting..... 6-7

K

Keyfob battery replacement..... 8-21
Keyless entry (See remote keyless entry system)..... 3-5
Keys 3-2

L

Label, Air conditioner specification label 10-13
Label, Emission control information label 10-13
Label, F.M.V.S.S. certification label 10-12
Labels
 Air bag warning labels..... 1-21
 Engine serial number 10-12
 Vehicle identification number (VIN) 10-11
LATCH system..... 1-44
Light
 Air bag warning light..... 1-21
 Bulb replacement 8-22
 Front fog light switch 2-27
 Headlight switch..... 2-24
 Headlights Bulb replacement 8-22
 Interior lights..... 2-45
 Personal light..... 2-46
 Replacement 8-22

Vanity mirror lights..... 2-47
Warning/indicator lights and
 audible reminders 2-10, 2-15
 Xenon headlights 2-23
Lights, Exterior and interior light replacement..... 8-23
Loading information (See vehicle loading
 information)..... 10-14
Lock
 Door locks..... 3-3
 Glass hatch lock 3-12
 Glove box lock 2-34
 Power door lock..... 3-3
Low fuel warning light..... 2-14
Luggage hooks 2-36
Luggage rack 2-40
Luggage storage (See vehicle loading information) .. 2-35

M

Maintenance
 Battery 8-13
 Chassis and body 9-12
 Emission control system..... 9-11
 General maintenance..... 9-2
 Inside the vehicle..... 9-3

INDEX

Maintenance precautions	8-2
Outside the vehicle	9-3
Periodic maintenance schedules.....	9-5
Seat belt maintenance.....	1-34
Under the hood and vehicle.....	9-4
Maintenance for offroad driving (4x4 only)....	9-11
Meters and gauges	2-3
Mirror	
Inside mirror	3-17
Outside mirror control	3-17
Outside mirrors	3-17

N

Net, Cargo net	2-38
New vehicle break-in	5-34
Nissan vehicle Immobilizer System.....	2-18

O

Odometer.....	2-4
Oil	
Capacities and recommended fuel/lubricants.....	10-2
Changing engine oil	8-8
Changing engine oil filter	8-9

Checking engine oil level	8-7
Engine oil	8-7
Engine oil viscosity.....	10-6
Outside mirror control	3-17
Outside mirrors.....	3-17
Outside temperature display	2-6
Overdrive switch	5-15
Overheat, If your vehicle overheats.....	6-10
Owner's Manual/Service Manual order information	10-25

P

Parking	
Brake check	8-18
Parking brake check.....	5-16
Parking brake operation.....	5-16
Parking on hills	5-16
Parking/parking on hills	5-43
Payload weight capacity	10-16
Periodic maintenance schedules	9-5
Personal light.....	2-46
Phone, Car phone or CB radio	4-25
Power	
Front seat adjustment	1-3

Power door lock.....	3-3
Power outlet.....	2-30
Power steering fluid.....	8-11
Power steering system.....	5-44
Power windows	2-41
Pre-tensioner seat belt system	1-19
Precautions	
Audio operation precautions.....	4-8
Cruise control precautions.....	5-17
Driving safety.....	5-5
Maintenance precautions	8-2
On child restraints	1-34
On seat belt usage.....	1-23
On-pavement and offroad driving precautions.....	5-4
Precautions on supplemental restraint system.....	1-8
Precautions when starting and driving.....	5-2
Push starting.....	6-9

R

Rack, Luggage rack	2-40
Radio.....	4-6
Car phone or CB radio.....	4-25
Steering wheel audio controls.....	4-23

INDEX

Readiness for inspection/maintenance (I/M) test (US only)	10-23
Rear door lock, Child safety rear door lock	3-4
Rear power point	2-30
Rear seat adjustment	1-4
Rear window wiper and washer switch	2-21
Registering your vehicle in another country	10-11
Remote keyless entry system	3-5
Reporting safety defects (US only).....	10-23
Roadside assistance program.....	6-2
Rollover	5-4

S

Safety

Child seat belts.....	1-26
Reporting safety defects (US only).....	10-23
Towing safety.....	10-18

Seat

Belt warning light.....	1-23
Belt warning light and chime	2-14
Driver side memory	3-18

Seat adjustment

Front power seat adjustment	1-3
Rear seat adjustment.....	1-4

Seat belt(s)

Child safety	1-26
Infants and small children.....	1-27
Injured persons	1-27
Larger children.....	1-27
Pre-tensioner seat belt system	1-19
Precautions on seat belt usage	1-23
Pregnant women	1-27
Seat belt cleaning	7-5
Seat belt extenders.....	1-33
Seat belt hook	1-31
Seat belt maintenance.....	1-34
Seat belts	1-23
Three-point type with retractor	1-28
Two-point type without retractor (rear center lap belt).....	1-31

Seat(s)

Heated seats.....	2-29
Seats.....	1-2

Security system, vehicle security system

Security systems (Infiniti Vehicle Immobilizer System), Engine start	2-19
Security systems (See vehicle security system)	2-18
Servicing air conditioner.....	4-3, 4-6
Shift lock release	5-14

Shifting, Automatic transmission.....

Shoulder belt height adjustment, For front seats	1-30
Side air bag system (See supplemental side air bag system).....	1-17
Spark plugs.....	8-15
Speedometer	2-4

Starting

Before starting the engine.....	5-9
Jump starting.....	6-7
Precautions when starting and driving.....	5-2
Push starting.....	6-9
Starting the engine.....	5-10

Steering

Power steering fluid.....	8-11
Power steering system.....	5-44
Steering wheel switch for audio controls.....	4-23
Tilting steering wheel.....	3-15

Storage

Sun shade	2-43
Sun visors.....	3-16
Sunglasses holder	2-32
Sunroof	2-42
Electric sunroof	2-42
Supplemental air bag warning labels.....	1-21
Supplemental air bag warning light	1-21, 2-14

INDEX

Supplemental front air bag system	1-15
Supplemental restraint system.....	1-8
Precautions on supplemental restraint system.....	1-8
Supplemental side air bag system	1-17
Switch	
4WD shift switch operations.....	5-39
Audio control	4-23
Front fog light switch	2-27
Glass hatch and outside mirror defogger switch.....	2-22
Hazard warning flasher switch.....	2-28
Headlight switch.....	2-24
Ignition switch.....	5-8
Ignition switch automatic transmission models..	5-11
Overdrive switch.....	5-15
Power door lock switch.....	3-4
Turn signal switch.....	2-27

T

Tachometer	2-4
Temperature display	2-6
Temperature gauge, Engine coolant temperature gauge	2-5

Theft (Infiniti Vehicle Immobilizer System), Engine start	2-19
Three way catalyst	5-3
Tilting steering wheel	3-15
Tire	
Flat tire.....	6-2
Uniform tire quality grading	10-21
Tires	
Tire chains	8-31
Tire placard.....	10-13
Tire pressure.....	8-29
Tire rotation.....	8-31
Types of tires	8-30
wheel/tire size	10-10
Wheels and tires	8-29
Tonneau cover	2-38
Top tether strap child restraints.....	1-45
Towing	
Tow truck towing.....	6-11
Towing a trailer.....	10-16
Towing load/specification chart.....	10-16
Towing safety.....	10-18
Trailer towing.....	10-16
Transceiver, HomeLink® Universal Transceiver	2-47
Transfer case shifting procedures	5-35

Transmission	
Automatic transmission fluid (ATF).....	8-10
Driving with automatic transmission.....	5-11
Transmission selector lever lock release.....	5-14
Transmitter (See remote keyless entry system)	3-5
Traveling or registering your vehicle in another country	10-11
Turn signal switch.....	2-27

U

Underbody cleaning.....	7-3
Uniform tire quality grading	10-21

V

Vanity mirror lights.....	2-47
Vehicle	
Dimensions and weights.....	10-10
Identification number (VIN).....	10-11
Loading information.....	10-14
Recovery (freeing a stuck vehicle).....	6-14
Security system.....	2-18
Ventilators	4-2

INDEX

W

Warning

Hazard warning flasher switch.....	2-28
Warning/indicator lights and audible reminders	2-10
Warning labels, Air bag warning labels.....	1-21
Warning light	
4WD warning light.....	5-41
Air bag warning light.....	1-21, 2-14
Anti-lock brake warning light	2-10
Automatic transmission park warning light.....	2-11
Brake warning light.....	2-12
Door open warning light.....	2-13
Low fuel warning light.....	2-14
Seat belt warning light and chime	2-14
Warning lights	2-10
Warranty, Emission control system warranty.....	10-22
Washer switch	
Rear window wiper and washer switch	2-21
Windshield wiper and washer switch.....	2-21
Washing	7-2
Waxing	7-3
Weights (See dimensions and weights).....	10-10
Wheel/tire size	10-10

Wheels and tires.....	8-29
Cleaning aluminum alloy wheels.....	7-3
Window washer fluid	8-12
Window(s)	
Cleaning.....	7-3
Power windows	2-41
Windshield wiper and washer switch.....	2-21
Wiper	
Rear window wiper and washer switch	2-21
Windshield wiper and washer switch	2-21
Wiper blades	8-16

X

Xenon headlights	2-23
------------------------	------

GAS STATION INFORMATION

FUEL RECOMMENDATION:

Use unleaded regular gasoline with an octane rating of at least 87 AKI (Anti-Knock Index) number (Research octane number 91).

For improved vehicle performance, INFINITI recommends the use of unleaded premium gasoline with an octane rating of at least 91 AKI number (Research octane number 96).



CAUTION

Using a fuel other than that specified could adversely affect the emission control devices and systems, and could also affect warranty coverage.

Under no circumstances should a leaded gasoline be used, since this will damage the three way catalyst.

For additional information, see “Capacities and recommended fuel/lubricants” in the “10.

Technical and consumer information” section.

ENGINE OIL RECOMMENDATION:

- API Certification Mark
- API grade SG/SH, Energy Conserving I & II or API grade SJ or SL, Energy Conserving
- ILSAC grade GF-I, GF-II & GF-III
- SAE 5W-30 viscosity oil is preferred for all ambient temperatures.
See “Capacities and recommended fuel/lubricants” in the “10. Technical and consumer information” section for engine oil and oil filter recommendation.

COLD TIRE PRESSURE:

See tire placard affixed to the glove box lid.

NEW VEHICLE BREAK-IN PROCEDURE RECOMMENDATION:

During the first 1,000 miles (1,600 km) of vehicle use, follow the recommendations outlined in the “Break-in schedule” Information found in the “5. Starting and driving” section of this Owner’s Manual. Follow these recommendations for the future reliability and economy of your new vehicle.

