

# Foreword

Your INFINITI represents a new way of thinking about vehicle design. It integrates advanced engineering and superior craftsmanship with a simple, refined aesthetic sensitivity associated with traditional Japanese culture.

The result is a different notion of luxury and beauty. The car itself is important, but so is the sense of harmony that the vehicle evokes in its driver, and the sense of satisfaction you feel with the INFINITI — from the way it looks and drives to the high level of retailer service.

To ensure that you enjoy your INFINITI to the fullest, we encourage you to read this Owner's Manual immediately. It explains all of the features, controls and performance characteristics of your INFINITI; it also provides important instructions and safety information.

**A separate Warranty Information Booklet can be found in your Owner's literature portfolio. Always carry it with you when you take your INFINITI to an authorized retailer. The portfolio contents provide complete information about all warranties covering this vehicle, the periodic maintenance required to keep the warranties in effect as well as the INFINITI Roadside Assistance program.**

**Additionally, a separate Customer Care and Lemon Law Information Booklet will explain how to resolve any concerns you may have with your vehicle, as well as clarify your rights under your state's lemon law.**

INFINITI is dedicated to providing a satisfying ownership experience for as long as you own your car. Should you have any questions regarding your INFINITI or your INFINITI dealer, please contact our Consumer Affairs department at 1-800-662-6200. In Hawaii 1-808-836-0888 (Oahu number). In Canada 1-800-361-4792. Thank you.

## **READ FIRST — THEN DRIVE SAFELY**

**Before driving your vehicle please read your Owner's Manual carefully. This will ensure familiarity with controls and maintenance requirements, assisting you in the safe operation of your vehicle.**



## **WARNING**

### **IMPORTANT SAFETY INFORMATION REMINDERS FOR SAFETY!**

**Follow these important driving rules to help ensure a safe and comfortable trip for you and your passengers!**

- **Never drive under the influence of alcohol or drugs.**
- **Always observe posted speed limits and never drive too fast for conditions.**
- **Always use your seat belts and appropriate child restraint systems. Preteen children should be seated in the rear seat.**
- **Always provide information about the proper use of vehicle safety features to all occupants of the vehicle.**
- **Always review this Owner's Manual for important safety information.**

## MODIFICATION OF YOUR VEHICLE

**This vehicle should not be modified. Modification could affect its performance, safety or durability, and may even violate governmental regulations. In addition, damage or performance problems resulting from modifications may not be covered under INFINITI warranties.**

## WHEN READING THE MANUAL

**This manual includes information for all options available on this model. Therefore, you may find some information that does not apply to your vehicle.**

All information, specifications and illustrations in this manual are those in effect at the time of printing. INFINITI reserves the right to change specifications or design at any time without notice.

## IMPORTANT INFORMATION ABOUT THIS MANUAL

You will see various symbols in this manual. They are used in the following ways:



### WARNING

**This is used to indicate the presence of a hazard that could cause death or serious personal injury. To avoid or reduce the risk, the procedures must be followed precisely.**



### CAUTION

**This is used to indicate the presence of a hazard that could cause minor or moderate personal injury or damage to your vehicle. To avoid or reduce the risk, the procedures must be followed carefully.**

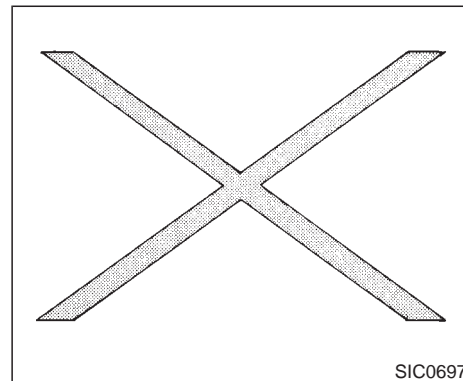

SIC0697

If you see this symbol, it means **Do not do this** or **Do not let this happen**.



If you see a symbol similar to these in an illustration, it means the arrow points to the front of the vehicle.



Arrows in an illustration that are similar to these indicate movement or action.



Arrows in an illustration that are similar to these call attention to an item in the illustration.

CALIFORNIA PROPOSITION 65  
WARNING



**WARNING**

**Engine exhaust, some of its constituents, and certain vehicle components contain or emit chemicals known to the State of California to cause cancer and birth defects or other reproductive harm. In addition, certain fluids contained in vehicles and certain products of component wear contain or emit chemicals known to the State of California to cause cancer and birth defects or other reproductive harm.**



© 2004 NISSAN MOTOR CO., LTD.  
TOKYO, JAPAN

All rights reserved. No part of this Owner's Manual may be reproduced or stored in a retrieval system, or transmitted in any form, or by any means, electronic, mechanical, photocopying, recording or otherwise, without the prior written permission of Nissan Motor Co., Ltd.



# Table of Contents

<b>Illustrated table of contents</b>	<b>0</b>
<b>Safety — Seats, seat belts and supplemental air bags</b>	<b>1</b>
<b>Instruments and controls</b>	<b>2</b>
<b>Pre-driving checks and adjustments</b>	<b>3</b>
<b>Heater, air conditioner and audio systems</b>	<b>4</b>
<b>Starting and driving</b>	<b>5</b>
<b>In case of emergency</b>	<b>6</b>
<b>Appearance and care</b>	<b>7</b>
<b>Maintenance and do-it-yourself</b>	<b>8</b>
<b>Technical and consumer information</b>	<b>9</b>
<b>Index</b>	<b>10</b>



# 0 Illustrated table of contents

Exterior .....	0-2	Instrument panel .....	0-6
Sedan .....	0-2	Meters and gauges .....	0-7
Coupe .....	0-3	Engine compartment locations.....	0-8
Passenger compartment .....	0-4		
Sedan .....	0-4		
Coupe .....	0-5		

## EXTERIOR

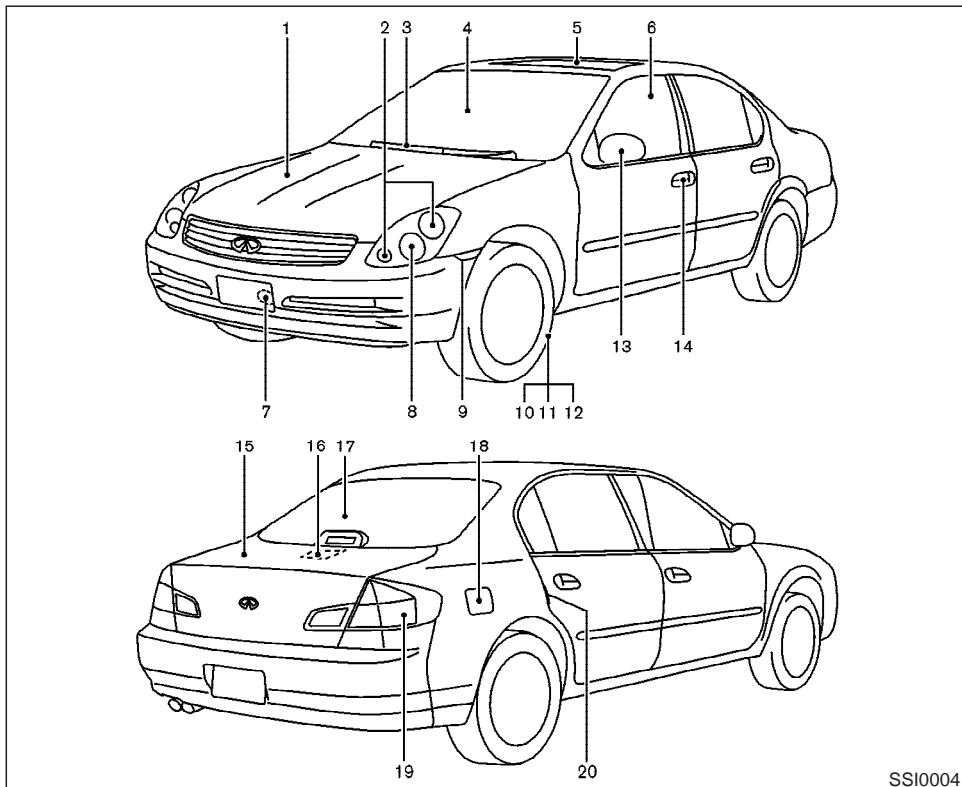

## SEDAN

1. Engine hood (Page 3-9)
2. Headlight and turn signal switch (P.2-18)
3. Windshield wiper and washer switch (P.2-17)
4. Windshield (P.8-19)
5. Sunroof (P.2-37)
6. Power windows (P.2-34)
7. Towing hook (P.6-12)
8. Fog light switch (P.2-22)
9. Front side marker light (P.8-29)
10. Tire pressure (P.8-33)
11. Flat tire (P.6-2)
12. Tire chains (P.8-38)
13. Mirrors (P.3-16)
14. Door locks, keyfob, keys (P.3-3)
15. Trunk lid (P.3-10)
16. Interior trunk lid release (P.3-11)
17. Rear window defogger switch (P.2-18)
18. Fuel filler lid (P.3-12)
19. Rear combination light (P.8-29)
20. Child safety locks (P.3-5)

SSI0004



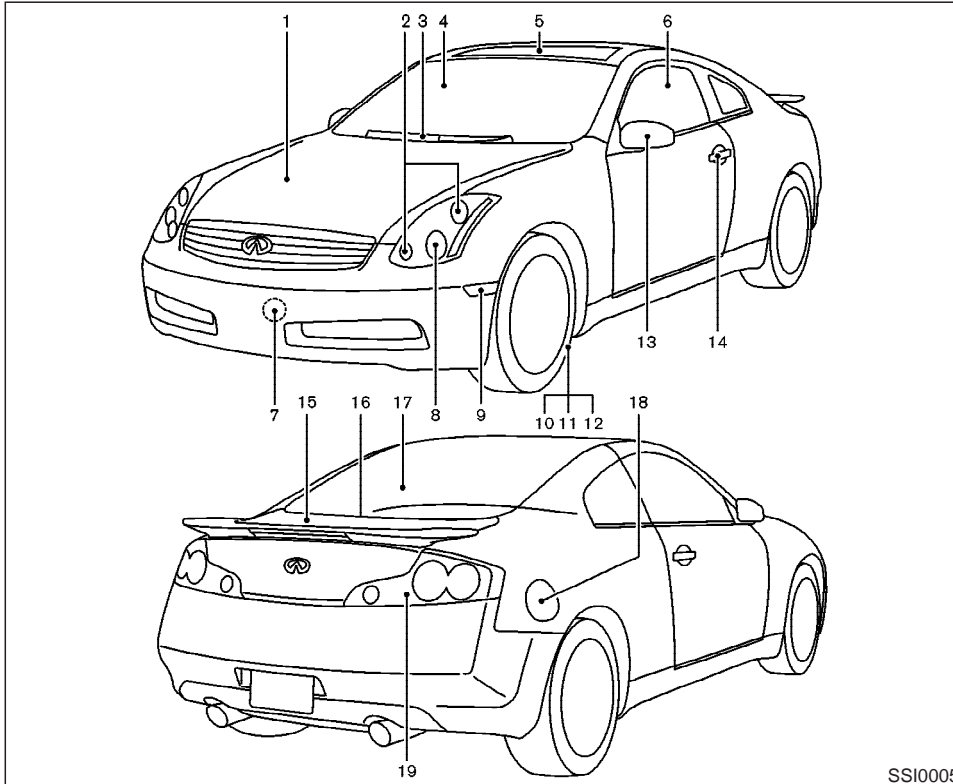

SSI0005

## COUPE

1. Engine hood (P.3-9)
2. Headlight and turn signal switch (P.2-18)
3. Windshield wiper and washer switch (P.2-17)
4. Windshield (P.8-19)
5. Sunroof (P.2-37)
6. Power windows (P.2-34)
7. Towing hook (P.6-12)
8. Fog light switch (P.2-22)
9. Front side marker light (P.8-29)
10. Tire pressure (P.8-33)
11. Flat tire (P.6-2)
12. Tire chains (P.8-38)
13. Mirrors (P.3-16)
14. Door locks, keyfob, keys (P.3-3)
15. Trunk lid (P.3-10)
16. Interior trunk lid release (P.3-11)
17. Rear window defogger switch (P.2-18)
18. Fuel filler lid (P.3-12)
19. Rear combination light (P.8-29)

## PASSENGER COMPARTMENT

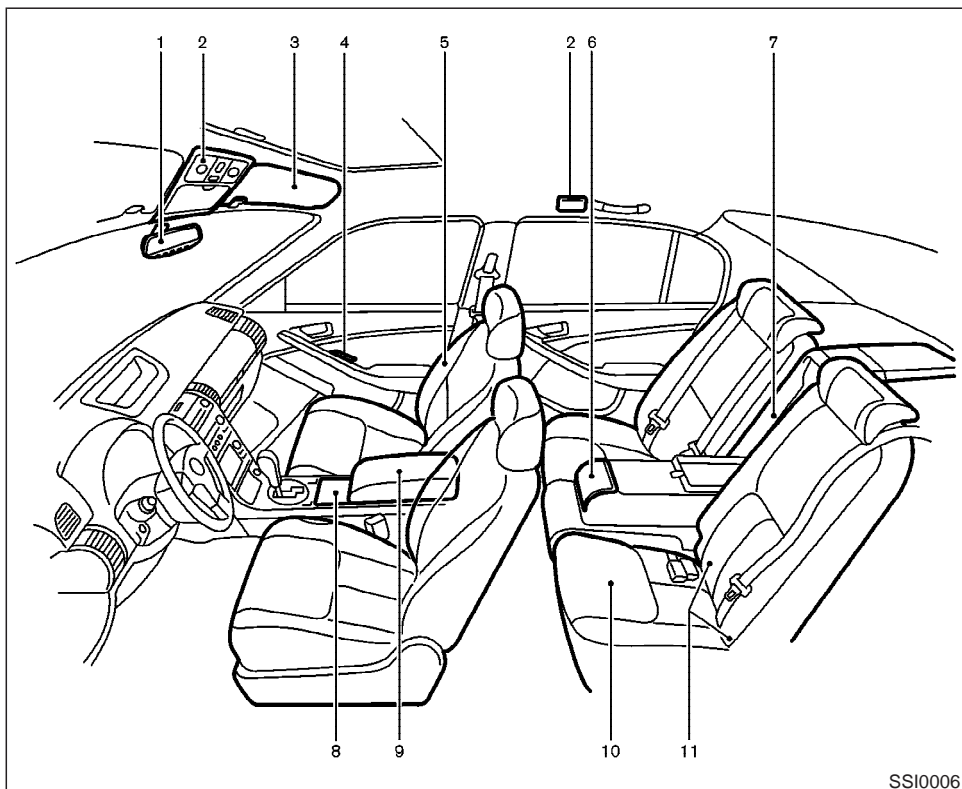

## SEDAN

1. Automatic anti-glare mirror, HomeLink® (P.3-16, 2-40)
2. Interior lights (P.2-39)
3. Sun visors (P.3-15)
4. Power windows (P.2-34)
5. Front seat (P.1-2)
6. Rear cup holders (P.2-30)
7. Interior trunk access (P.1-8)
8. Front cup holders (P.2-29)
9. Console box (P.2-31)
10. Rear seat (P.1-7)
11. LATCH system (P.1-40)

SSI0006

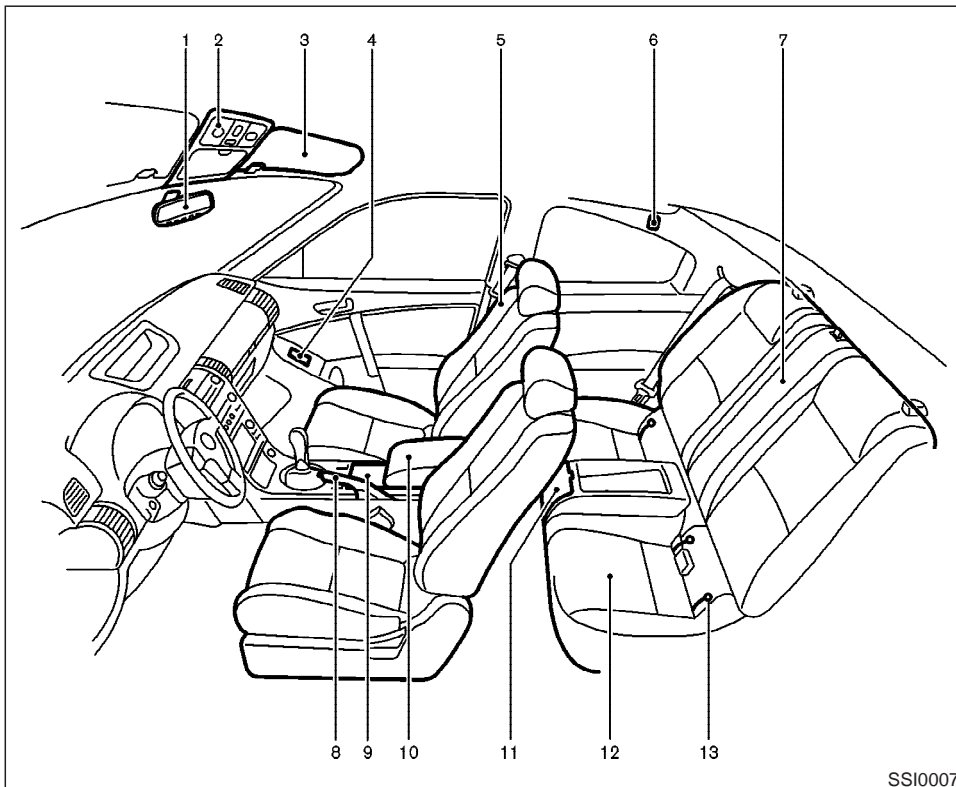

SSI0007

## COUPE

1. Automatic anti-glare mirror, HomeLink® (P.3-16, 2-40)
2. Interior lights (P.2-39)
3. Sun visors (P.3-15)
4. Power windows (P.2-34)
5. Front seat (P.1-2)
6. Coat hook (P.2-33)
7. Interior trunk access (P.1-8)
8. Parking brake (MT models) (P.5-15)
9. Front cup holders (P.2-29)
10. Console box (P.2-31)
11. Rear cup holders (P.2-29)
12. Rear seat (P.1-7)
13. LATCH system (P.1-40)

## INSTRUMENT PANEL

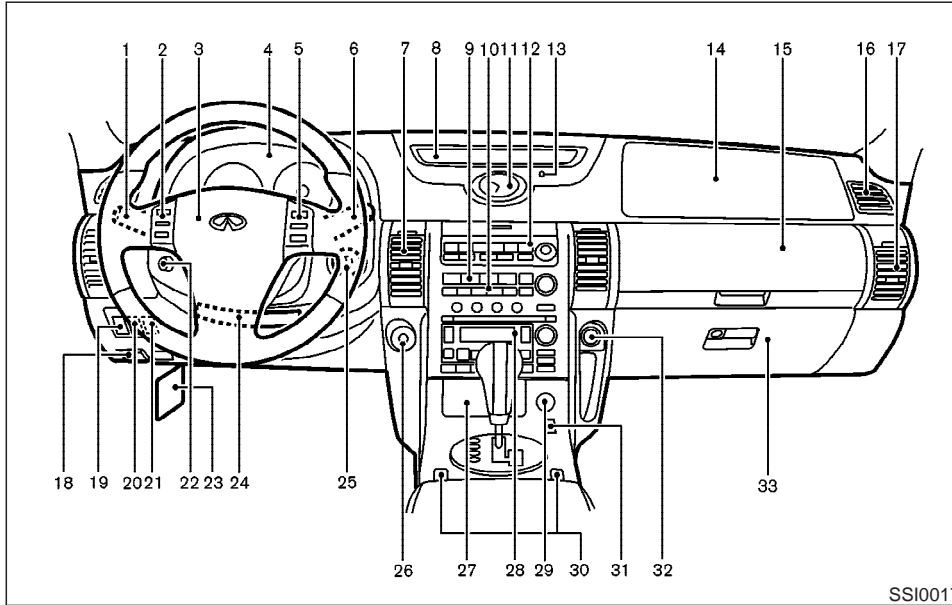

1. Headlight, fog light and turn signal switch (P.2-18)
2. Steering switch for audio control (P.4-17)
3. Driver supplemental air bag (P.1-11)/Horn (P.2-23)
4. Meters/gauges (P.2-3)
5. Cruise control main/set switch (P.5-16)
6. Windshield wiper/washer switch (P.2-17)
7. Center ventilator (P.4-2)
8. Center display - Compass (P.2-6), Air conditioner (P.4-3), Ambient temperature (P.4-5)
9. Rear window and outside mirror (if so equipped) defogger switch (P.2-18)

10. Heater/air conditioner control (P.4-3)
11. Clock (P.2-26)
12. Navigation system\* (if so equipped)
13. Security indicator light (P.2-15)
14. Passenger supplemental air bag (P.1-11)
15. Upper glove box (Except for Navigation system equipped models) (P.2-31)
16. Side window defogger
17. Side ventilator (P.4-2)
18. Hood lock release handle (P.3-9)
19. Instrument brightness control switch (P.2-21)
20. Trunk lid release switch (P.3-11)
21. VDC (Vehicle Dynamic Control) OFF switch (P.2-25)
22. Outside mirror remote control (P.3-16)
23. Fuse box (P.8-23)
24. Tilting steering wheel lock lever (P.3-15)
25. Ignition switch/steering lock (P.5-6)
26. Cigarette lighter (P.2-27)
27. Ashtray (P.2-27)/Pocket
28. Radio/cassette player (P.4-6)/CD player (P.4-8)
29. Hazard warning flasher switch (P.2-23)
30. Heated seat switch (P.2-24)
31. Snow mode switch (if so equipped) (P.2-25)
32. Power outlet (P.2-26)
33. Glove box (P.2-30)

\*: Refer to the separate Navigation System Owner's Manual.

## METERS AND GAUGES

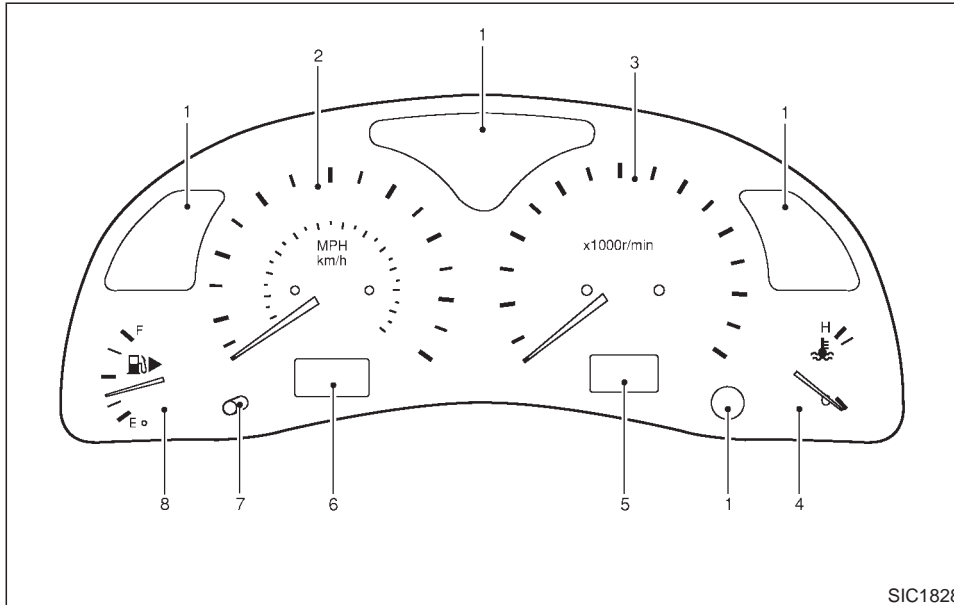

1. Warning/Indicator lights (P.2-9)
2. Speedometer (P.2-3)
3. Tachometer (P.2-4)
4. Engine coolant temperature gauge (P.2-4)
5. Automatic transmission position indicator (P.5-9)
6. Odometer (Total/Twin trip) (P.2-3)
7. Reset knob for trip odometer (P.2-3)
8. Fuel gauge (P.2-5)

## ENGINE COMPARTMENT LOCATIONS

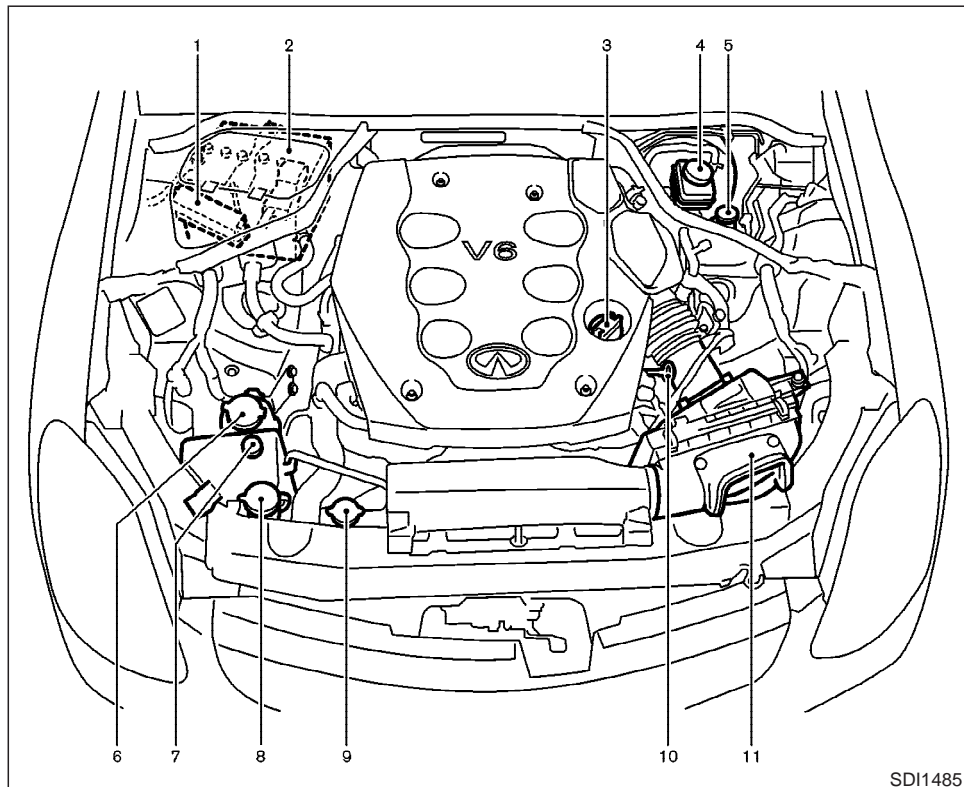

### VQ35DE

1. Fuse/fusible link holder (P.8-23)
2. Battery (P.8-16)
3. Engine oil filler cap (P.8-10)
4. Brake fluid reservoir (P.8-14)
5. Clutch fluid reservoir (P.8-14)
6. Power steering fluid reservoir (P.8-13)
7. Engine coolant reservoir (P.8-8)
8. Windshield washer fluid reservoir (P.8-15)
9. Radiator filler cap (P.8-9)
10. Engine oil dipstick (P.8-10)
11. Air cleaner (P.8-19)

SD11485

# 1 Safety — Seats, seat belts and supplemental air bags

Seats .....	1-2	Pregnant women .....	1-28
Front manual seat adjustment .....	1-2	Injured persons.....	1-29
Front power seat adjustment (if so equipped) .....	1-4	Three-point type seat belt with retractor .....	1-29
Rear seat adjustment .....	1-7	Seat belt extenders .....	1-32
Head restraint adjustment .....	1-10	Seat belt maintenance .....	1-32
Active head restraint (front seats).....	1-10	Child restraints .....	1-33
Supplemental restraint system.....	1-11	Precautions on child restraints.....	1-33
Precautions on supplemental restraint system .....	1-11	Installation on rear seat outboard or center positions .....	1-35
Supplemental air bag warning labels.....	1-23	LATCH (Lower Anchors and Tethers for CHildren) system .....	1-40
Supplemental air bag warning light.....	1-23	Top tether strap child restraint .....	1-41
Seat belts .....	1-25	Installation on front passenger seat.....	1-43
Precautions on seat belt usage .....	1-25		
Child safety.....	1-28		

## SEATS

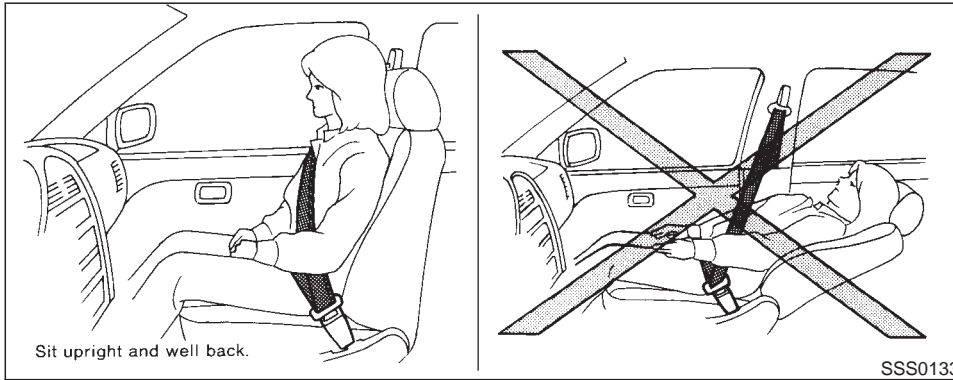

### WARNING

- Do not ride in a moving vehicle when the seatback is reclined. This can be dangerous. The shoulder belt will not be against your body. In an accident you could be thrown into it and receive neck or other serious injuries. You could also slide under the lap belt and receive serious internal injuries.

## FRONT MANUAL SEAT ADJUSTMENT



### WARNING

- Do not adjust the driver's seat while driving so full attention may be given to vehicle operation. The seat may move suddenly and could cause loss of control of the vehicle.
- After adjustment, gently rock in the seat to make sure it is securely locked.

- For most effective protection when the vehicle is in motion, the seat should be upright. Always sit well back in the seat and adjust the seat belt properly. See "Precautions on seat belt usage" later in this section.



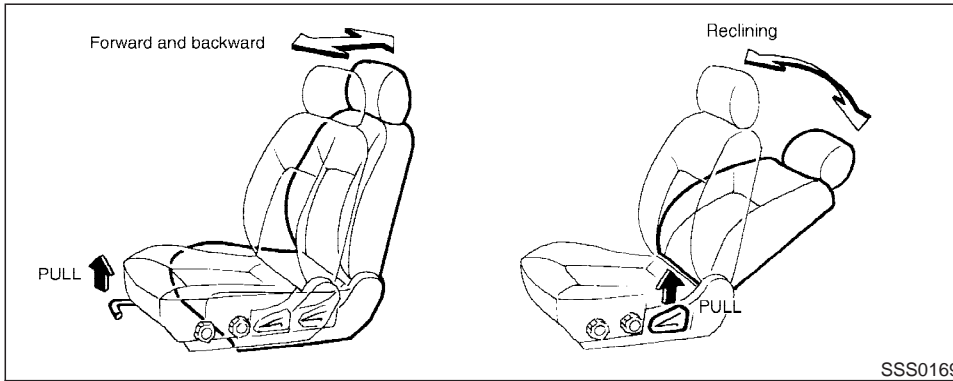

### Forward and backward

Pull the lever up while you slide the seat forward or backward to the desired position. Release the lever to lock the seat in position.

### Reclining

To recline the seatback, pull the lever up and lean back. To bring the seatback forward again, pull the lever and move your body forward. The seatback will move forward.

The reclining feature allows adjustment of the seatback for occupants of different sizes to help obtain proper seat belt fit. (See "Precautions on seat belt usage" later in this section.) Also, the seatback may be reclined to allow occupants to rest when the vehicle is parked.

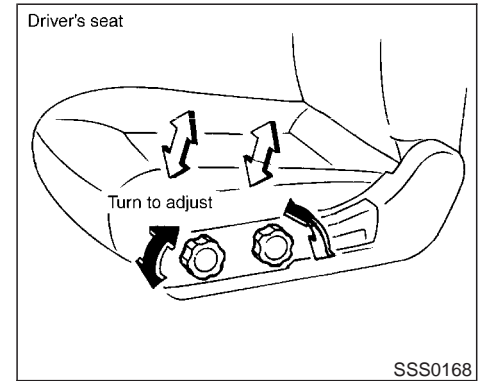

### Seat lifter (if so equipped for driver's seat)

Turn either dial to adjust the angle and height of the seat cushion to the desired position.

## FRONT POWER SEAT ADJUSTMENT (if so equipped)

### **WARNING**

- Do not adjust the driver's seat while driving so full attention may be given to vehicle operation.
- Do not leave children unattended inside the vehicle. They could unknowingly activate switches or controls. Unattended children could become involved in serious accidents.

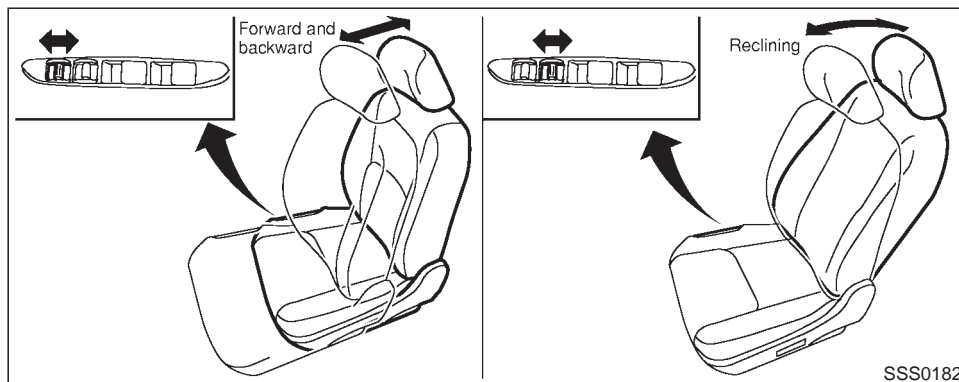

### Operating tips

- The seat motor has an auto-reset overload protection circuit. If the motor stops during operation, wait 30 seconds, then reactivate the switch.
- Do not operate the power seat for a long period of time when the engine is off. This will discharge the battery.

See “Automatic seat positioner” in the “3. Pre-driving checks and adjustments” for automatic seat positioner operation.

### Forward and backward (Sedan)

Moving the switch forward or backward will slide the seat forward or backward to the desired position.

### Reclining (Sedan)

Move the recline switch backward until the desired angle is obtained. To bring the seatback forward again, move the switch forward and move your body forward. The seatback will move forward.

The reclining feature allows adjustment of the seatback for occupants of different sizes to help obtain proper seat belt fit. (See “Precautions on seat belt usage” later in this section.) Also, the seatback may be reclined to allow occupants to rest when the vehicle is parked.

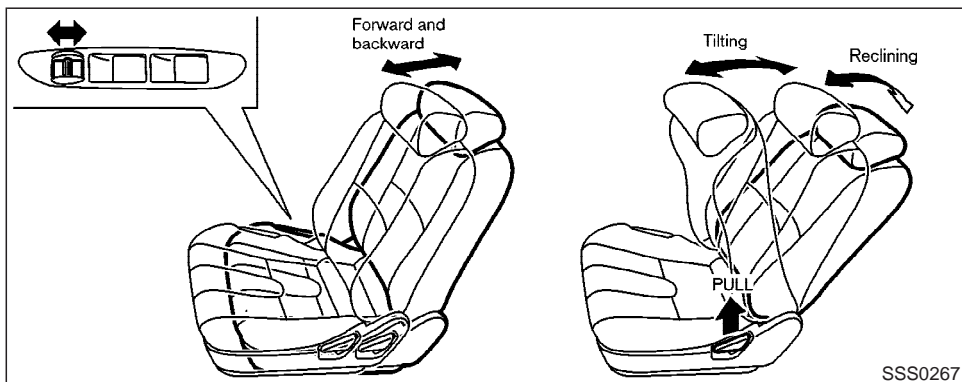

### Forward and backward (Coupe)

Moving the switch forward or backward will slide the seat forward or backward to the desired position.

### Tilting and reclining (Coupe)

To recline the seatback, pull the lever up and lean back. To bring the seatback forward again, pull the lever up and move your body forward. The seatback will move forward.

To access the rear seat, pull the lever up.

The reclining feature allows adjustment of the seatback for occupants of different sizes to help obtain proper seat belt fit. (See "Precautions on seat belt usage" later in this section.) Also, the seatback may be reclined to allow occupants to rest when the vehicle is parked.

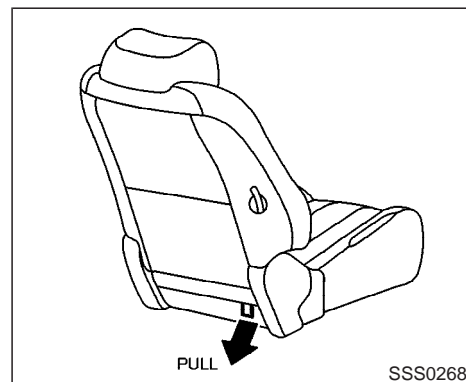

The driver's seatback can also be tilted forward by firmly pulling the strap.

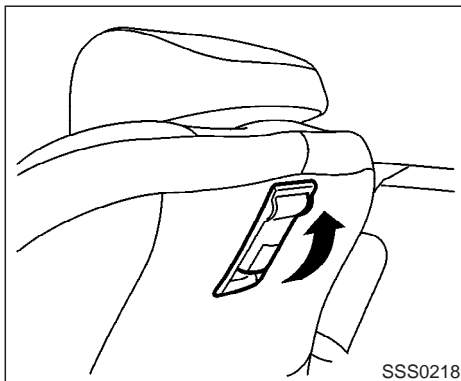

### Seatback lever (Coupe, front passenger side)

The seatback lever can be used in the same way as the reclining lever on the side of the seat from the driver's seat.

### Walk-in mechanism (Coupe)

- When the seatback lever or the reclining lever on the side of the seat is pulled upward, the seatback will tilt down, moving the seat forward. This makes it easier to get in and out of the rear seat.
- To return the seat to its original position, raise the seatback and lock the seat. The seat will return to its original position.
- The front passenger seat will stop at 7 in (175 mm) from its front most position to retain space for the rear passenger.



### CAUTION

- **When returning the seat to its original position, confirm the seat and seatback are locked properly.**
- **Be careful not to pinch your hand or foot or bump your head when operating the walk-in seat. The seatback will fold down rapidly.**
- **Do not put any objects in front or rear of the seat. They may be pinched and damaged.**

The automatic forwarding and reversing will not work or stop under the following conditions:

- When the vehicle speed is above 4 MPH (7 km/h).
- When the seat belt is fastened.
- When the selector lever is not in the P (Park) position (Automatic transmission model's driver's seat) or the parking brake is not applied (Manual transmission model's driver's seat)
- When the door is closed.
- When the slide adjusting switch is operated.

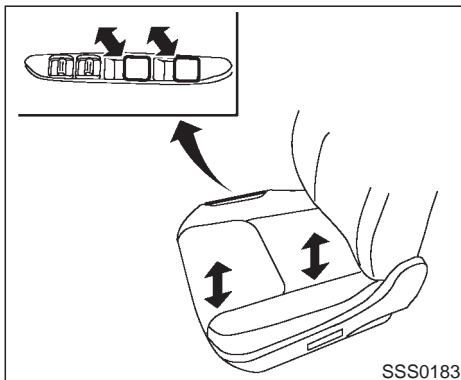

### Seat lifter (Driver's seat)

Pull the switch up or push it down to adjust the angle and height of the seat cushion.

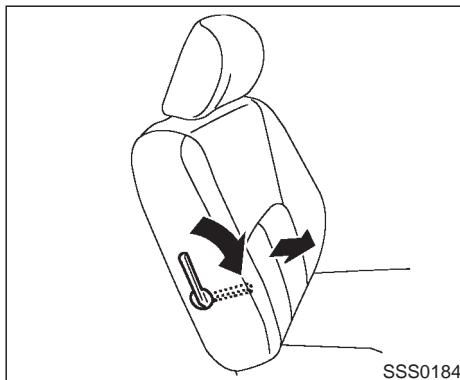

### Lumbar support (Driver's seat)

The lumbar support feature provides lower back support to the driver. Move the lever up or down to adjust the seat lumbar area.

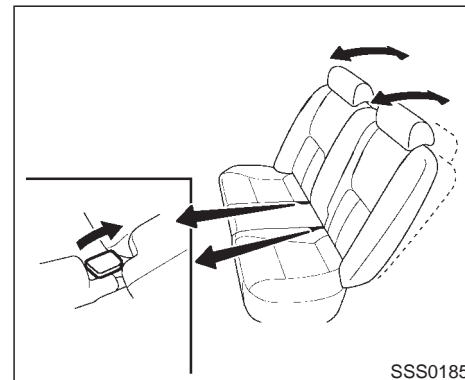

### REAR SEAT ADJUSTMENT

#### Reclining (if so equipped)

Pull the reclining lever and position the seat back at the desired angle. Release the reclining lever after positioning the seat at the desired angle.



### WARNING

- Do not ride in a moving vehicle when the seatback is reclined. This can be dangerous. The shoulder belt will not

be against your body. In an accident you could be thrown into it and receive neck or other serious injuries. You could also slide under the lap belt and receive serious internal injuries.

- For the most effective protection when the vehicle is in motion, the seat should be upright. Always sit well back in the seat and adjust the seat belt properly. See “Seat belts” later in this section for precautions on seat belt usage.
- After adjustment, check to be sure the seat is securely locked.

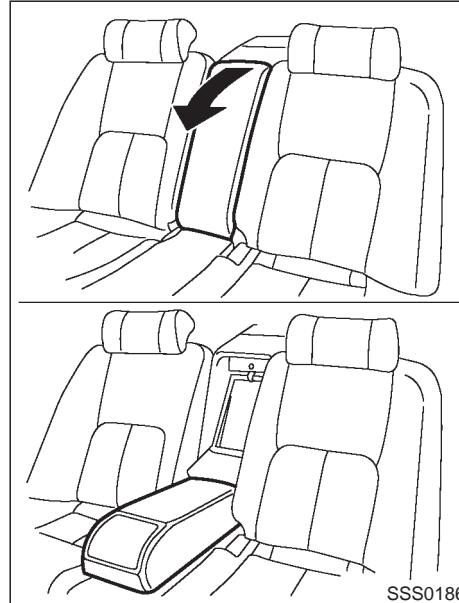

#### Armrest (if so equipped)

Pull the armrest forward until it is horizontal.

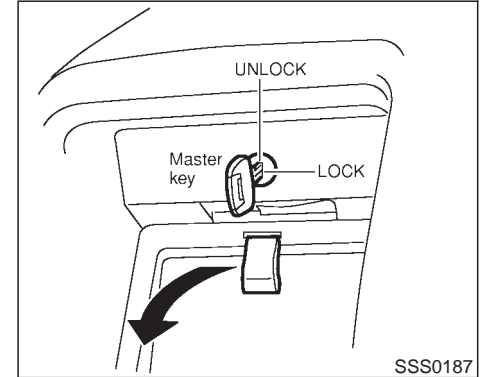

#### Interior trunk access

##### **Sedan:**

Pull the partition down to access the trunk from the rear seat.

**The partition can be locked using the master key to prevent unauthorized access.**

Remove the key while opening or closing the partition. Otherwise, the partition may be damaged.

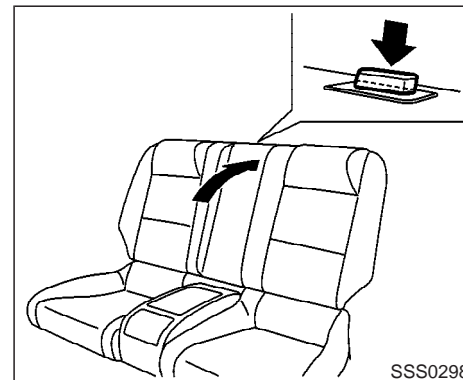
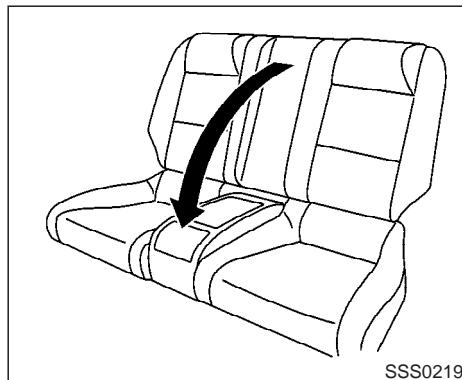
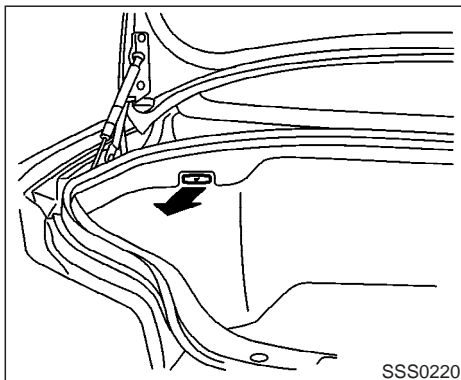

### Coupe:

Pull the handle on the left side of the trunk and push the seatback forward to access the trunk from the rear seat.



### WARNING

Properly secure all cargo to help prevent it from sliding or shifting. Do not place cargo higher than the seatbacks. In a sudden stop or collision, unsecured cargo could cause personal injury.

When raising the seatback, make sure to lock the seatback. The pop up knob on the seatback will latch in when the seatback is locked.

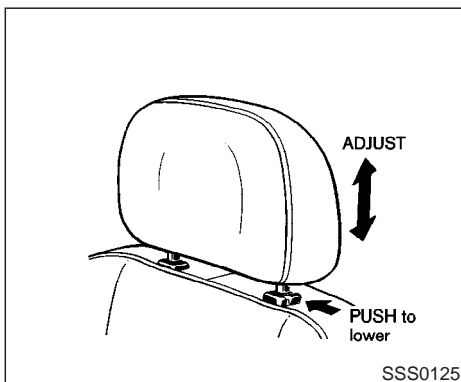

SSS0125

## HEAD RESTRAINT ADJUSTMENT

To raise the head restraint, just pull it up. To lower, push the lock knob and push the head restraint down.

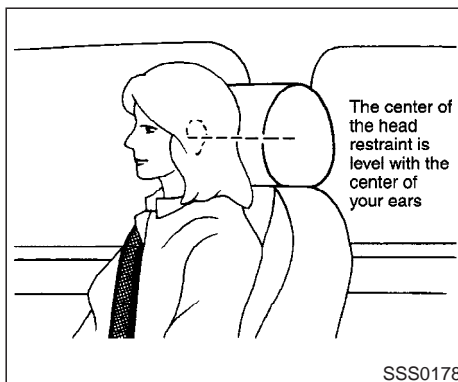

SSS0178

Adjust the head restraints so the center is level with the center of your ears.



## WARNING

Head restraints should be adjusted properly as they may provide significant protection against injury in an accident. Do not remove them. Check the adjustment after someone else uses the seat.

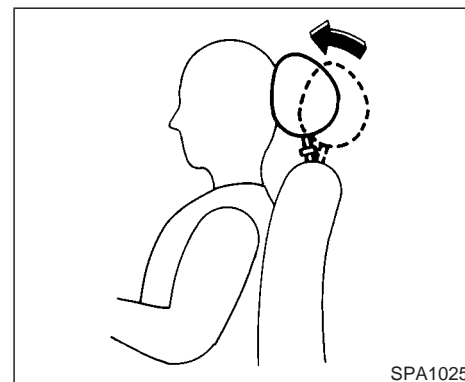

SPA1025

## ACTIVE HEAD RESTRAINT (front seats)



## WARNING

- Always adjust the head restraints properly as specified in the previous section. Failure to do so can reduce the effectiveness of the active head restraint.



- **Active head restraints are designed to supplement other safety systems. Always wear seat belts. No system can prevent all injuries in any accident.**
- **Do not attach anything to the head restraint stalks. Doing so could impair active head restraint function.**

The head restraint moves forward utilizing the force that the seatback receives from the occupant in a rear-end collision. The movement of the head restraint helps support the occupant's head by reducing its backward movement and helping absorb some of the forces that may lead to whiplash type injuries.

Active head restraints are effective for collisions at low to medium speeds in which it is said that whiplash injury occurs most.

Active head restraints operate only in certain rear-end collisions. After the collision, the head restraints return to their original positions.

Properly adjust the active head restraints as described in the previous section.

## SUPPLEMENTAL RESTRAINT SYSTEM

### PRECAUTIONS ON SUPPLEMENTAL RESTRAINT SYSTEM

This Supplemental Restraint System (SRS) section contains important information concerning the driver and passenger front impact supplemental air bags, front seat side-impact supplemental air bags, curtain air bags and front seat pre-tensioner seat belts.

#### **Supplemental front impact air bag system:**

This system can help cushion the impact force to the face and chest of the driver and front passenger in certain frontal collisions.

#### **Supplemental side-impact air bag system:**

This system can help cushion the impact force to the chest area of the driver and front passenger in certain side impact collisions. The front seat side-impact supplemental air bags are designed to inflate on the side where the vehicle is impacted.

#### **Supplemental curtain side-impact air bag system:**

This system can help cushion the impact force to the head of occupants in front and rear outboard seating positions in certain side impact collisions. The curtain side-impact air bags are designed to inflate on the side where the vehicle is impacted.

These supplemental restraint systems are designed to **supplement** the crash protection

provided by the driver and passenger seat belts and are **not a substitute** for them. Seat belts should always be correctly worn and the occupant seated a suitable distance away from the steering wheel, instrument panel and door finishers. (See "Seat belts" later in this section for instructions and precautions on seat belt usage.)

**After turning the ignition key to the ON position, the supplemental air bag warning light illuminates. The supplemental air bag warning light will turn off after about 7 seconds if the systems are operational.**

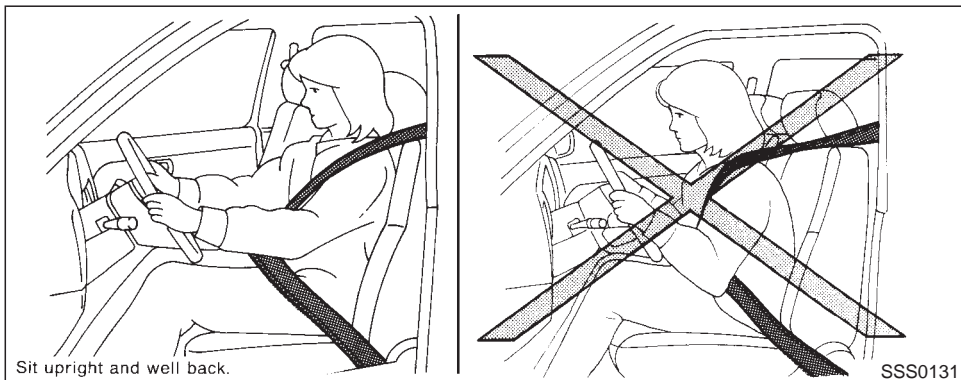

## WARNING

- The supplemental front air bags ordinarily will not inflate in the event of a side impact, rear impact, roll over, or lower severity frontal collision. Always wear your seat belts to help reduce the risk or severity of injury in various kinds of accidents.
- The seat belts and the supplemental front air bags are most effective when

you are sitting well back and upright in the seat. Front air bags inflate with great force. If you are unrestrained, leaning forward, sitting sideways or out of position in any way, you are at greater risk of injury or death in a crash. You may also receive serious or fatal injuries from the supplemental front air bag if you are up against it when it inflates. Always sit back against the seatback and as far away as practical from the steering wheel

or instrument panel. Always use the seat belts.

- The driver and front passenger seat belt buckles are equipped with sensors that detect if the seat belts are fastened. The air bag system monitors the severity of a collision and then inflates the air bags based on belt usage. Failure to properly wear seat belts can increase the risk or severity of injury in an accident.
- Keep hands on the outside of the steering wheel. Placing them inside the steering wheel rim could increase the risk that they are injured when the supplemental front air bag inflates.

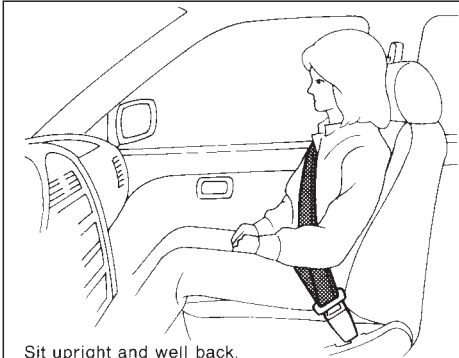

Sit upright and well back.

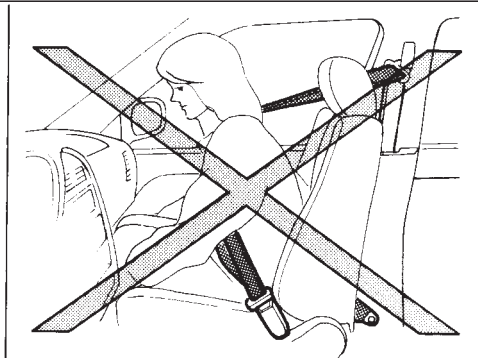

SSS0132

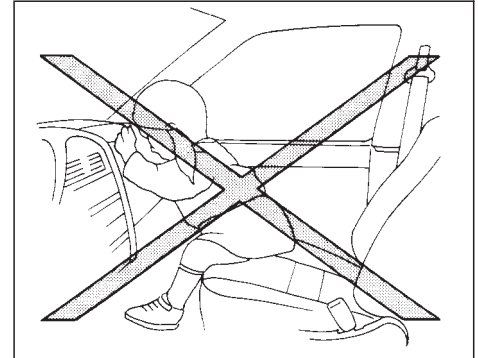

SSS0006

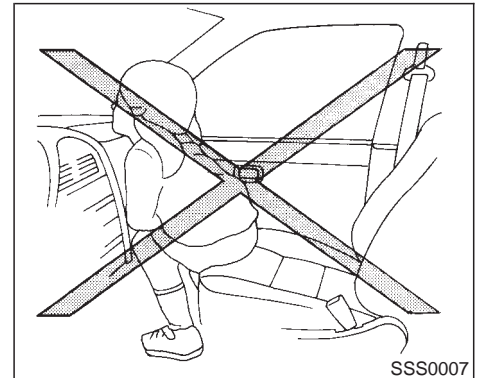

SSS0007

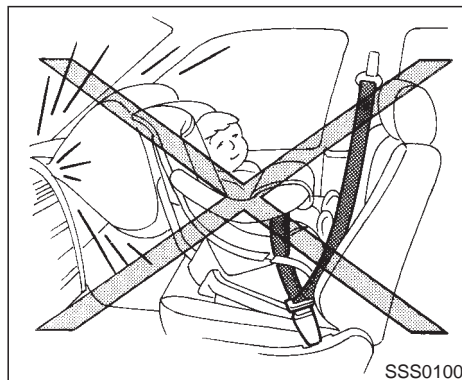
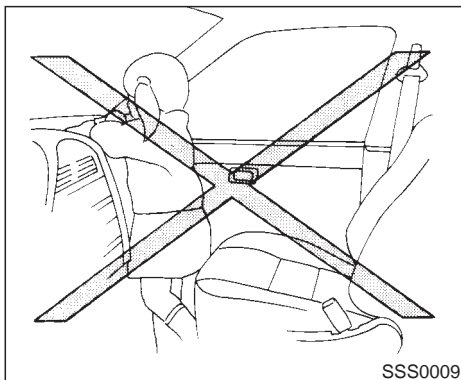
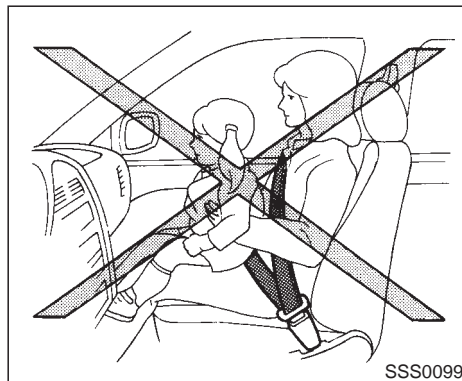
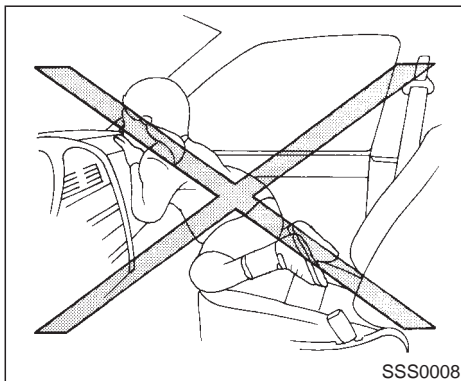

## WARNING

- Never let children ride unrestrained or extend their hands or face out of the window. Do not attempt to hold them in your lap or arms. Some examples of dangerous riding positions are shown in the previous illustrations.
- Children may be severely injured or killed when the supplemental front air bags, side air bags or curtain side-impact air bags inflate if they are not properly restrained. Preteens and children should be properly restrained in the rear seat if possible.
- Also never install a rear facing child restraint in the front seat. An inflating supplemental front air bag could seriously injure or kill your child. For additional information, see “Child restraints” later in this section.

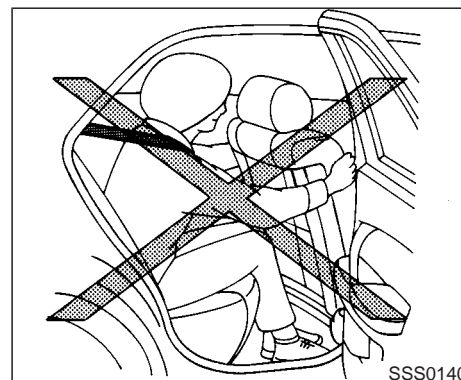
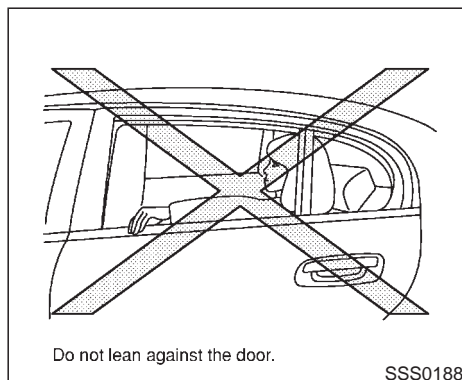
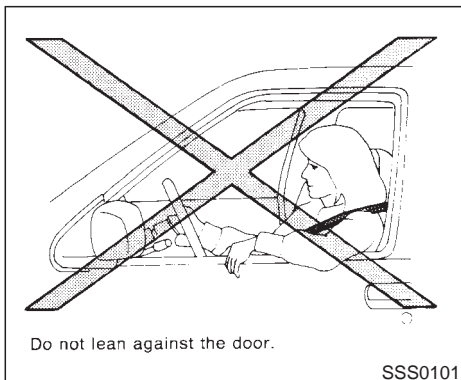

## WARNING

Supplemental side air bag and curtain side-impact air bag:

- The supplemental side air bag and curtain side-impact air bag ordinarily will not inflate in the event of a frontal impact, rear impact, rollover or lower severity side collision. Always wear your seat belts to help reduce the risk or severity of injury in various kinds of accidents.

- The seat belts, the supplemental side air bag and curtain side-impact air bag are most effective when you are sitting well back and upright in the seat. The side air bag and curtain side-impact air bag inflate with great force. Do not allow anyone to place their hand, leg or face near the side air bag on the side of the seatback of the front seat or near the side roof rails. Do not allow anyone sitting in the front seat or rear outboard seats

to extend their hand out of the window or lean against the door. Some examples of dangerous riding positions are shown in the previous illustrations.

- When sitting in the rear seat, do not hold onto the seatback of the front seat. If the supplemental side air bag inflates, you may be seriously injured. Be especially careful with children, who should always be properly restrained.

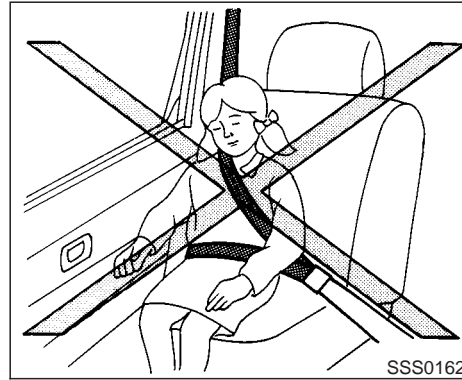
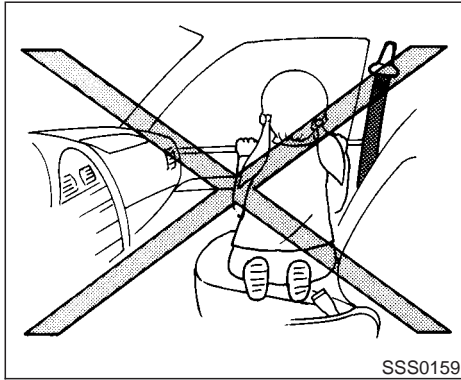

- Do not use seat covers on the front seatbacks. They may interfere with supplemental side air bag inflation.

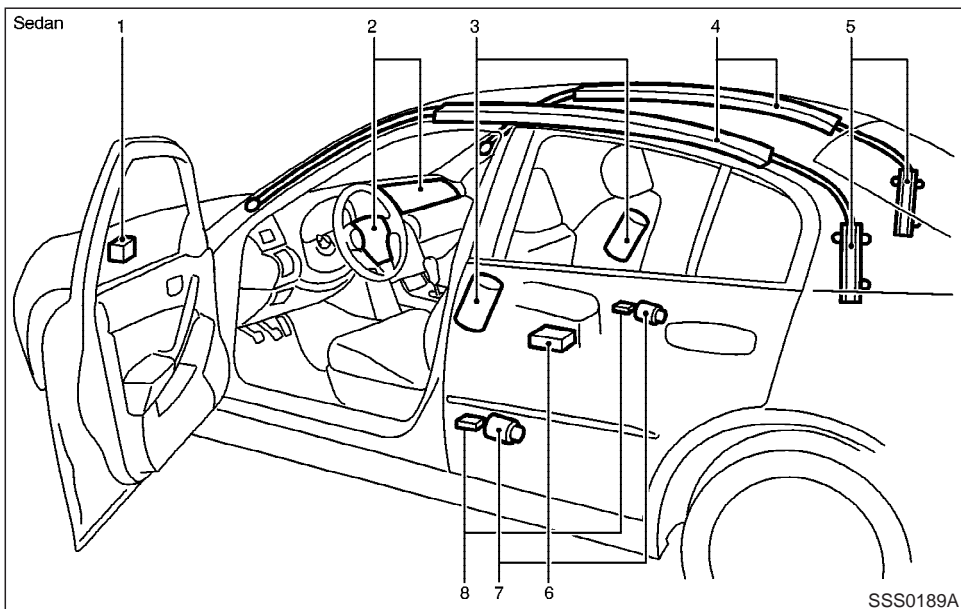

## Supplemental air bag systems

1. Crash zone sensor
2. Supplemental front air bag modules
3. Supplemental side air bag modules
4. Supplemental curtain side-impact air bags
5. Supplemental curtain side-impact air bag modules
6. Diagnosis sensor unit
7. Seat belt pre-tensioner
8. Satellite sensors

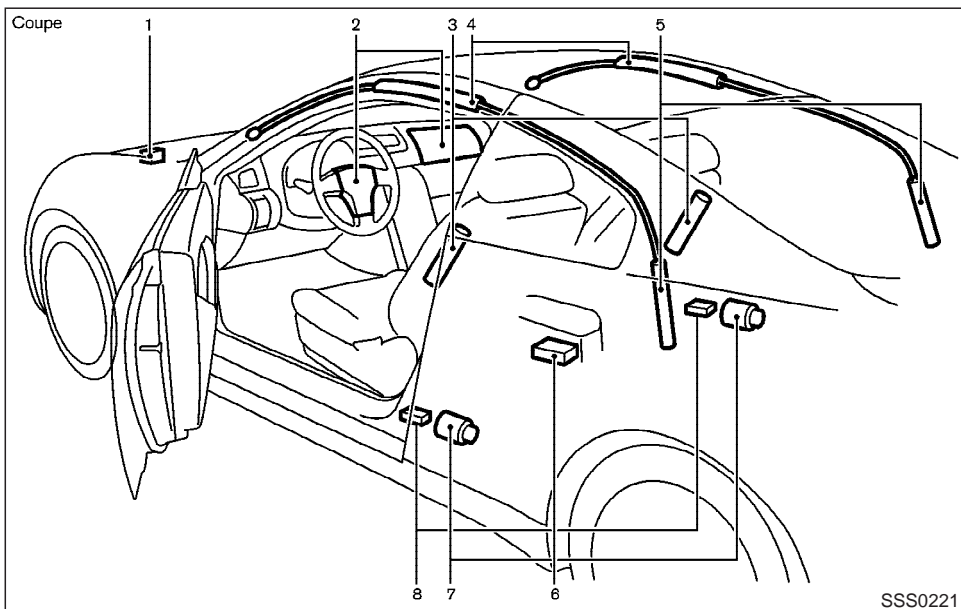

SSS0221

The driver supplemental air bag is located in the center of the steering wheel; the front passenger supplemental air bag is mounted in the instrument panel above the glove box. These systems are designed to meet optional certification requirements under U.S. regula-

tions. They are also permitted in Canada. The optional certification allows front air bags to be designed to inflate somewhat less forcefully than previously. **However, all of the information, cautions and warnings in this manual still apply and must be followed.** The front

air bags are designed to inflate in higher severity frontal collisions, although they may inflate if the forces in another type of collision are similar to those of a higher severity frontal impact. They may not inflate in certain frontal collisions. Vehicle damage (or lack of it) is not always an indication of proper supplemental air bag operation.

The supplemental air bag system has dual stage inflators for both the driver and passenger air bags. The system monitors information from the crash zone sensor, the diagnosis sensor unit and seat belt buckle sensors that detect if the seat belts are fastened, inflator operation is based on the severity of a collision and whether the seat belts are being used. Only one front air bag may inflate in a crash, depending on the crash severity and whether the front occupants are belted or unbelted. This does not indicate improper performance of the system. If you have any questions about the performance of your air bag system, please contact your INFINITI dealer.

When the supplemental front air bag inflates, a fairly loud noise may be heard, followed by release of smoke. This smoke is not harmful and does not indicate a fire. Care should be taken not to inhale it, as it may cause irritation and choking. Those with a history of a breath-



ing condition should get fresh air promptly.

Supplemental front air bags, along with the use of seat belts, help to cushion the impact force on the face and chest of the front occupants. They can help save lives and reduce serious injuries. However, an inflating front air bag may cause facial abrasions or other injuries. Front air bags do not provide restraint to the lower body.

The seat belts should be correctly worn and the driver and passenger seated upright as far as practical away from the steering wheel or instrument panel. The supplemental front air bags inflate quickly in order to help protect the front occupants. Because of this, the force of the front air bag inflating can increase the risk of injury if the occupant is too close to, or is against the air bag module during inflation. The air bag will deflate quickly after the collision is over.

**After turning the ignition key to the ON position, the supplemental air bag warning light illuminates. The supplemental air bag warning light will turn off after about 7 seconds if the system is operational.**



## WARNING

- **Do not place any objects on the steering wheel pad or on the instrument panel. Also, do not place any objects between any occupant and the steering wheel or instrument panel. Such objects may become dangerous projectiles and cause injury if the supplemental front air bag inflates.**
- **Right after inflation, several air bag system components will be hot. Do not touch them; you may severely burn yourself.**
- **No unauthorized changes should be made to any components or wiring of the supplemental front air bag system. This is to prevent accidental inflation of the air bag or damage to the air bag system.**
- **Do not make unauthorized changes to your vehicle's electrical system, suspension system or front end structure. This could affect proper**

operation of the supplemental air bag system.

- **Tampering with the supplemental front air bag system may result in serious personal injury. Tampering includes changes to the steering wheel and the instrument panel assembly by placing material over the steering wheel pad, above the dashboard, or by installing additional trim material around the air bag system.**
- **Work around and on the supplemental front air bag system should be done by an authorized INFINITI dealer. Installation of electrical equipment should also be done by an authorized INFINITI dealer. The yellow and orange Supplemental Restraint System (SRS) wiring and connectors should not be modified or disconnected. Unauthorized electrical test equipment and probing devices should not be used on the air bag system.**

- A cracked windshield should be replaced immediately by a qualified repair facility. A cracked windshield could affect inflation of the supplemental air bag system.
- The SRS wiring harness connectors are yellow and orange for easy identification.

When selling your vehicle, we request that you inform the buyer about the supplemental front air bag system and guide the buyer to the appropriate sections in this Owner's Manual.

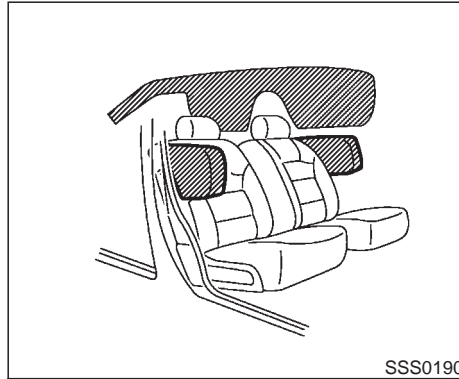

### Supplemental side air bag and curtain side-impact air bag systems

The supplemental side air bags are located in the outside of the seatback of the front seats. The supplemental curtain side-impact air bags are located in the side roof rails. These systems are designed to meet voluntary guidelines to help reduce the risk of injury to out-of-position occupants. **However, all of the information, cautions and warnings in this manual still apply and must be followed.** The supplemental side air bags and curtain side-impact air bags are designed to inflate in higher severity side collisions on the side of

the vehicle impacted, although they may inflate if the forces in another type of collision are similar to those of a higher severity side impact. They are designed to inflate on the side where the vehicle is impacted. They may not inflate in certain side collisions. Vehicle damage (or lack of it) is not always an indication of proper supplemental side air bag and curtain side-impact air bag operation.

When the supplemental side air bag and curtain side-impact air bag inflate, a fairly loud noise may be heard, followed by release of smoke. This smoke is not harmful and does not indicate a fire. Care should be taken not to inhale it, as it may cause irritation and choking. Those with a history of a breathing condition should get fresh air promptly.

Supplemental side air bags, along with the use of seat belts, help to cushion the impact force on the chest of the front occupants. Curtain side-impact air bags help to cushion the impact force to the head of occupants in the front and rear outboard seating positions. They can help save lives and reduce serious injuries. However, an inflating side air bag and curtain side-impact air bag may cause abrasions or other injuries. Supplemental side air bags and curtain side-impact air bags do not provide restraint to the lower body.

The seat belts should be correctly worn and

the driver and passenger seated upright as far as practical away from the side air bag. Rear seat passengers should be seated as far away as practical from the door finishers and side roof rails. The side air bags and curtain side-impact air bag inflate quickly in order to help protect the front occupants. Because of this, the force of the side air bag and curtain side-impact air bag inflating can increase the risk of injury if the occupant is too close to, or is against, these air bag modules during inflation. The side air bag and curtain side-impact air bag will deflate quickly after the collision is over.

After turning the ignition key to the ON position, the supplemental air bag warning light illuminates. The air bag warning light will turn off after about 7 seconds if the systems are operational.



## WARNING

- Do not place any objects near the seatback of the front seats. Also, do not place any objects (an umbrella, bag, etc.) between the front door finisher and the front seat. Such objects may become dangerous projectiles

and cause injury if the side air bag inflates.

- Right after inflation, several side air bag and curtain side-impact air bag system components will be hot. Do not touch them; you may severely burn yourself.
- No unauthorized changes should be made to any components or wiring of this side air bag and curtain side-impact air bag system. This is to prevent accidental inflation of the side air bag and curtain side-impact air bag or damage to the side air bag and curtain side-impact air bag system.
- Do not make unauthorized changes to your vehicle's electrical system, suspension system or side panel. This could affect proper operation of the supplemental side air bag and curtain side-impact air bag system.
- Tampering with the supplemental system may result in serious per-

sonal injury. For example, do not change the front seat by placing material near the seatback or by installing additional trim material, such as seat covers, around the side air bag.

- Work around and on the side air bag and curtain side-impact air bag system should be done by an authorized INFINITI dealer. Installation of electrical equipment should also be done by an authorized INFINITI dealer. The SRS wiring harnesses\* should not be modified or disconnected. Unauthorized electrical test equipment and probing devices should not be used on the side air bag system.

\* The SRS wiring harnesses are covered with yellow insulation either just before the harness connectors or over the complete harness for easy identification.

When selling your vehicle, we request that you inform the buyer about the side air bag and curtain side-impact air bag system and guide

the buyer to the appropriate sections in this Owner's Manual.

## Pre-tensioner seat belt system (For front seats)



### WARNING

- The pre-tensioner seat belt cannot be reused after activation. It must be replaced together with the retractor as a unit.
- If the vehicle becomes involved in a frontal collision but the pre-tensioner is not activated, be sure to have the pre-tensioner system checked and, if necessary, replaced by your INFINITI dealer.
- No unauthorized changes should be made to any components or wiring of the pre-tensioner seat belt system. This is to prevent accidental activation of the pre-tensioner seat belt or damage to the pre-tensioner seat belt operation. Tampering with the pre-tensioner seat belt system may result

**in serious personal injury.**

- **Work around and on the pre-tensioner system should be done by an authorized INFINITI dealer. Installation of electrical equipment should also be done by an authorized INFINITI dealer. Unauthorized electrical test equipment and probing devices should not be used on the pre-tensioner seat belt system.**
- **If you need to dispose of the pre-tensioner or scrap the vehicle, contact an authorized INFINITI dealer. Correct pre-tensioner disposal procedures are set forth in the appropriate INFINITI Service Manual. Incorrect disposal procedures could cause personal injury.**

The front seat pre-tensioner seat belt system activates in conjunction with the supplemental front air bag. Working with the seat belt retractor, it helps tighten the seat belt the instant the vehicle becomes involved in certain types of collisions, helping to restrain front seat occupants.

The pre-tensioner is encased with the seat belt's retractor. These seat belts are used the same as conventional seat belts.

When the pre-tensioner seat belt activates, smoke is released and a loud noise may be heard. The smoke is not harmful, but care should be taken not to inhale it as it may cause irritation and choking. Those with a history of a breathing condition should get fresh air promptly.

If any abnormality occurs in the pre-tensioner seat belt system, the supplemental air bag warning light  will not come on, will flash intermittently or will turn on for 7 seconds and remain on after the ignition key has been turned to the ON or START position. In this case, the pre-tensioner seat belt may not function properly. They must be checked and repaired. Take your vehicle to the nearest authorized INFINITI dealer.

When selling your vehicle, we request that you inform the buyer about the pre-tensioner seat belt system and guide the buyer to the appropriate sections in this Owner's Manual.

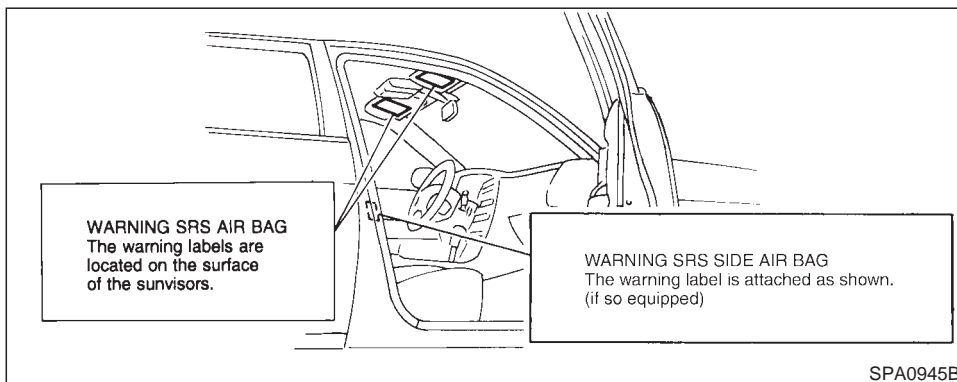

## SUPPLEMENTAL AIR BAG WARNING LABELS

Warning labels about the supplemental air bag system are placed in the vehicle as shown in the illustration.



## SUPPLEMENTAL AIR BAG WARNING LIGHT

The supplemental air bag warning light, displaying  in the instrument panel, monitors the circuits of the supplemental front air bag, supplemental side air bag and curtain side-impact air bag systems, and pre-tensioner seat belt. The circuits monitored by the air bag warning light are the diagnosis sensor unit, satellite sensors, front air bag modules, side air bag modules, curtain side-impact air bag modules, pre-tensioner seatbelt and all related wiring.

After turning the ignition key to the ON posi-

tion, the supplemental air bag warning light illuminates. The supplemental air bag warning light will turn off after about 7 seconds if the system is operational.

If any of the following conditions occur, the supplemental front air bag, supplemental side air bag and curtain side-impact air bag systems, and pre-tensioner seat belt need servicing:

- The supplemental air bag warning light remains on after approximately 7 seconds.
- The supplemental air bag warning light flashes intermittently.
- The supplemental air bag warning light does not come on at all.

Under these conditions, the supplemental front air bags, supplemental side air bags, curtain side-impact air bags and/or pre-tensioner seat belt may not operate properly. They must be checked and repaired. Take your vehicle to the nearest authorized INFINITI dealer.



## WARNING

If the supplemental air bag warning light is on, it could mean that the supplemen-

**tal front air bag, supplemental side air bag, curtain side-impact air bag systems and/or pretensioner seat belt will not operate in an accident.**

### Repair and replacement procedure

The supplemental front air bags, supplemental side air bags, curtain side-impact air bags and pre-tensioner seat belts are designed to activate on a one-time-only basis. As a reminder, unless it is damaged, the supplemental air bag warning light will remain illuminated after inflation has occurred. Repair and replacement of these systems should be done only by an authorized INFINITI dealer.

When maintenance work is required on the vehicle, the supplemental front air bags, side air bags, curtain side-impact air bags, related parts and pre-tensioner seat belt should be pointed out to the person conducting the maintenance. The ignition key should always be in the LOCK position when working under the hood or inside the vehicle.



## WARNING

- Once the supplemental front air bag, side air bag or curtain side-impact air bag has inflated, the air bag module will not function again and must be replaced. Additionally, if any of the supplemental front air bags inflate, the activated pre-tensioner seat belt must also be replaced. The air bag module and pre-tensioner seat belt system should be replaced by an authorized INFINITI dealer. The air bag modules and pre-tensioner seat belt system cannot be repaired.
- The supplemental front air bag and side air bag, curtain side-impact air bag systems and pre-tensioner seat belt system should be inspected by an authorized INFINITI dealer if there is any damage to the front end or side portion of the vehicle.
- If you need to dispose of these supplemental systems or scrap the vehicle, contact an authorized INFINITI dealer.

Correct disposal procedures are set forth in the appropriate INFINITI Service Manual. Incorrect disposal procedures could cause personal injury.

## SEAT BELTS

### PRECAUTIONS ON SEAT BELT USAGE

If you are wearing your seat belt properly adjusted, and you are sitting upright and well back in your seat, your chances of being injured or killed in an accident and/or the severity of injury may be greatly reduced. INFINITI strongly encourages you and all of your passengers to buckle up every time you drive, even if your seating position includes a supplemental air bag.

**Most states, provinces or territories require that seat belts be worn at all times when a vehicle is being driven.**

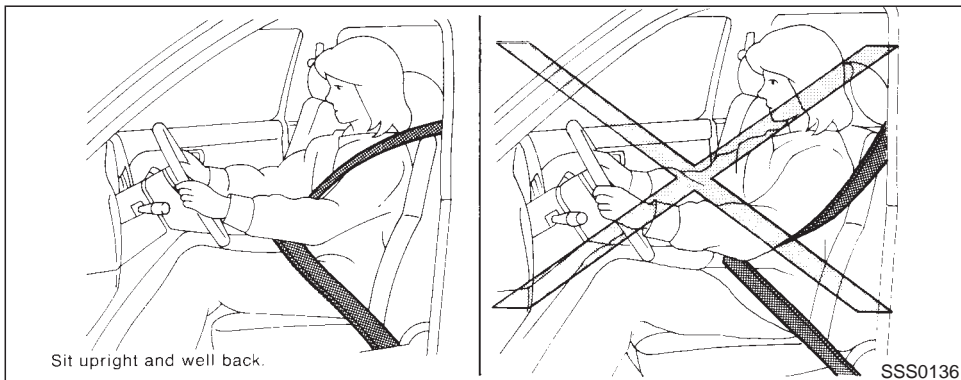

## WARNING

- Every person who drives or rides in this vehicle should use a seat belt at all times. Children should be properly restrained and, if appropriate, in a child restraint.
- The belt should be properly adjusted to a snug fit. Failure to do so may reduce the effectiveness of the entire restraint system and increase the

chance or severity of injury in an accident. Serious injury or death can occur if the seat belt is not worn properly.

- Always route the shoulder belt over your shoulder and across your chest. Never run the belt behind your back under your arm or across your neck. The belt should be away from your face and neck, but not falling off your shoulder.

- Position the lap belt as low and snug as possible around the hips, not the waist. A lap belt worn too high could increase the risk of internal injuries in an accident.
- Be sure the seat belt tongue is securely fastened to the proper buckle.
- Do not wear the belt inside out or twisted. Doing so may reduce its effectiveness.
- Do not allow more than one person to use the same belt.
- Never carry more people in the vehicle than there are seat belts.
- If the seat belt warning light glows continuously while the ignition is turned ON with all doors closed and all seat belts fastened, it may indicate a malfunction in the system. Have the system checked by an authorized INFINITI dealer.
- Once the pre-tensioner seat belt has activated, it cannot be reused and must be replaced together with the



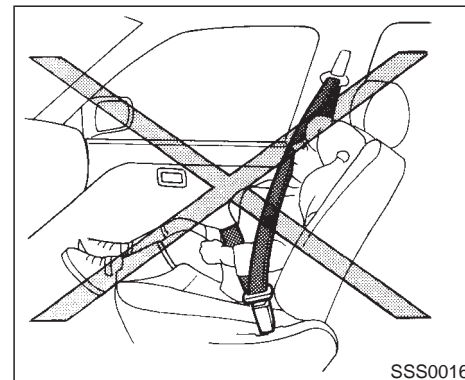
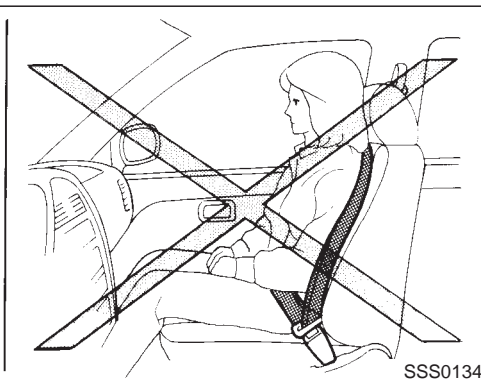
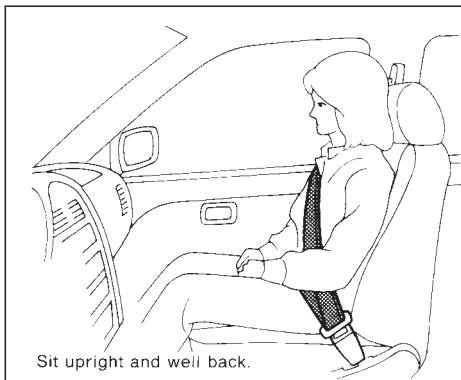

retractor. See your INFINITI dealer.

- Removal and installation of the pretensioner seat belt system components should be done by an authorized INFINITI dealer.
- All seat belt assemblies including retractors and attaching hardware should be inspected after any collision by your INFINITI dealer. INFINITI recommends that all seat belt assemblies in use during a collision be replaced unless the collision was minor and the belts show no damage

and continue to operate properly. Seat belt assemblies not in use during a collision should also be inspected and replaced if either damage or improper operation is noted.

- All child restraints and attaching hardware should be inspected after any collision. Always follow the restraint manufacturer's inspection instructions and replacement recommendations. The child restraints should be replaced if they are damaged.

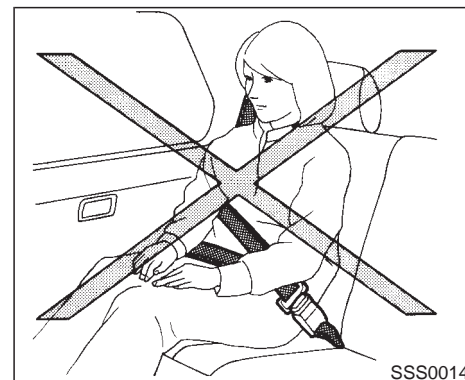

## CHILD SAFETY

**Children need adults to help protect them. They need to be properly restrained.**

The proper restraint depends on the child's size. Generally, infants (up to about 1 year and less than 20 lb (9 kg)) should be placed in rear facing child restraints. Front facing child restraints are available for children who outgrow rear facing child restraints.



### WARNING

**Infants and children need special protection. The vehicle's seat belts may not fit them properly. The shoulder belt may come too close to the face or neck. The lap belt may not fit over their small hip bones. In an accident, an improperly fitting seat belt could cause serious or fatal injury. Always use appropriate child restraints.**

All US states and provinces of Canada require the use of approved child restraints for infants and small children. (See "Child restraints" later in this section.)

In addition, there are many types of child

1-28 Safety — Seats, seat belts and supplemental air bags

restraints available for larger children which should be used for maximum protection.

**INFINITI recommends that all preteens and children be restrained in the rear seat if possible. According to accident statistics, children are safer when properly restrained in the rear seat than in the front seat.**

**This is especially important because your vehicle has a supplemental restraint system (air bag system) for the front passenger. See "Supplemental Restraint System" earlier in this section for precautions.**

Infants and small children

INFINITI recommends that infants and small children be placed in child restraints that comply with Federal Motor Vehicle Safety Standards or Canadian Motor Vehicle Safety Standards. You should choose a child restraint that fits your vehicle and always follow the manufacturer's instructions for installation and use.

Larger children

Children who are too large for child restraint systems should be seated and restrained by the seat belts which are provided.

If the child's seating position has a shoulder belt that fits close to the face or neck, the use of a booster seat (commercially available) may

help overcome this. The booster seat should raise the child so that the shoulder belt is properly positioned across the top, middle portion of the shoulder and the lap belt is low on the hips. The booster seat should fit the vehicle seat and have a label certifying that it complies with Federal Motor Vehicle Safety Standards or Canadian Motor Vehicle Safety Standards. Once the child has grown so the shoulder belt is no longer on or near the face and neck, use the shoulder belt without the booster seat.



### WARNING

**Never let a child stand or kneel on any seat and do not allow a child in the cargo areas while the vehicle is moving. The child could be seriously injured or killed in an accident or a sudden stop.**

PREGNANT WOMEN

INFINITI recommends that pregnant women use seat belts. The seat belt should be worn snug, and always position the lap belt as low as possible around the hips, not the waist. Place the shoulder belt over your shoulder and across your chest. Never run the lap/shoulder belt over your abdominal area. Contact your

doctor for specific recommendations.

## INJURED PERSONS

INFINITI recommends that injured persons use seat belts, depending on the injury. Check with your doctor for specific recommendations.

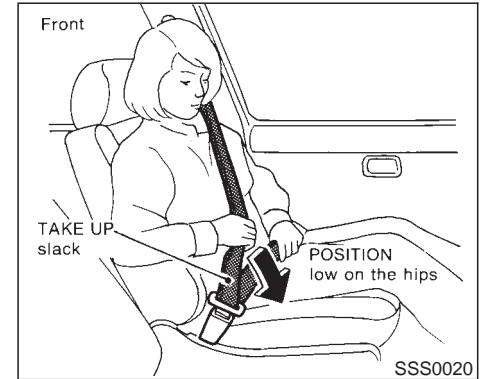
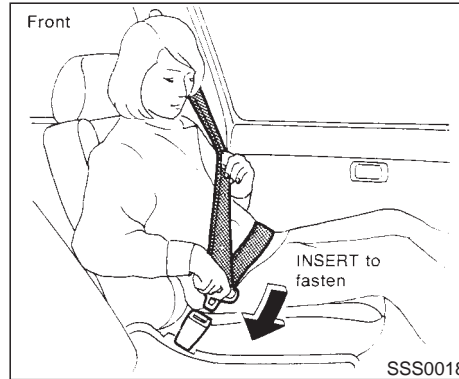

### THREE-POINT TYPE SEAT BELT WITH RETRACTOR



#### WARNING

- Every person who drives or rides in this vehicle should use a seat belt at all times.
- Do not ride in a moving vehicle when the seatback is reclined. This can be dangerous. The shoulder belt will not be against your body. In an accident

you could be thrown into it and receive neck or other serious injuries. You could also slide under the lap belt and receive serious internal injuries.

- For the most effective protection when the vehicle is in motion, the seat should be upright. Always sit well back in the seat and adjust the seat belt properly.



## Fastening the seat belts

1. Adjust the seat. See “Seats” earlier in this section.
2. Slowly pull the seat belt out of the retractor and insert the tongue into the buckle until it clicks.

**The retractor is designed to lock during a sudden stop or on impact. A slow pulling motion will permit the belt to move, and allow you some freedom of movement in the seat.**

If the seat belt cannot be pulled from its fully retracted position, firmly pull the belt and

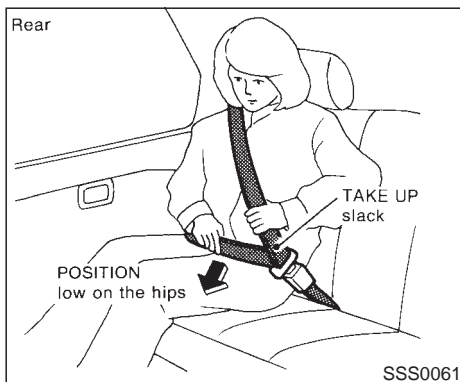

- release it. Then smoothly pull the belt out of the retractor.
3. Position the lap belt portion **low and snug on the hips** as shown.
  4. Pull the shoulder belt portion toward the retractor to take up extra slack. Make sure the shoulder belt is routed over your shoulder and across your chest.

The front passenger and rear seat belts have a cinching mechanism for child restraint installation. It is referred to as the automatic locking mode.

When the cinching mechanism is activated the

seat belt cannot be withdrawn again until the seat belt tongue is detached from the buckle and fully retracted. For additional information, see “Child restraints” later in this section.

**The automatic locking mode should be used only for child restraint installation. During normal seat belt use by a passenger, the locking mode should not be activated. If it is activated it may cause uncomfortable seat belt tension.**



## WARNING

**When fastening the seat belts, be certain that seatbacks are completely secured in the latched position. If they are not completely secured, passengers may be injured in an accident or sudden stop.**

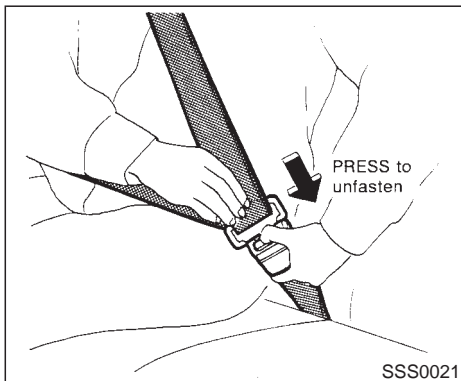

forward. The retractor should lock and restrict further belt movement.

If the retractor does not lock during this check or if you have any questions about belt operation, see your INFINITI dealer.

## Unfastening the seat belts

To unfasten the belt, press the button on the buckle. The seat belt will automatically retract.

## Checking seat belt operation

Your seat belt retractors are designed to lock belt movement using two separate methods:

- when the belt is pulled quickly from the retractor.
- when the vehicle slows down rapidly.

You can check their operation as follows:

- grasp the shoulder belt and pull quickly

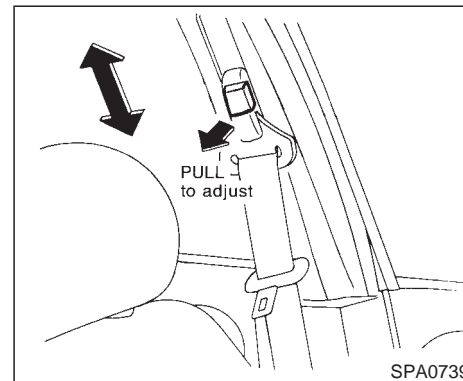

## Shoulder belt height adjustment (For Sedan front seats)

The shoulder belt anchor height should be adjusted to the position best suited for you. (See "Precautions on seat belt usage" earlier in this section.) To lower, pull the release button, and then move the shoulder belt anchor to the desired position, so that the belt passes over the shoulder. Release the adjustment button to lock the shoulder belt anchor into position.

To raise, move the adjuster up to the desired position while pulling the button.



## WARNING

- After adjustment, release the adjustment button and try to move the shoulder belt down to make sure it is securely fixed in position.
- The shoulder belt anchor height should be adjusted to the position best for you. Failure to do so may reduce the effectiveness of the entire restraint system and increase the chance or severity of injury in an accident.

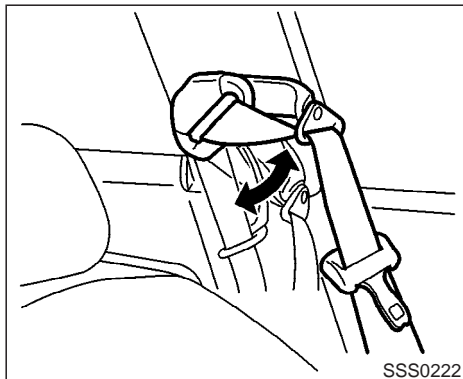

### Shoulder belt guide (Coupe)

The shoulder arm can be adjusted to allow easier access to the shoulder belt. The arm can also be folded down to allow rear seat passengers easier access.

### SEAT BELT EXTENDERS

If, because of body size or driving position, it is not possible to properly fit the lap-shoulder belt and fasten it, an extender is available. The extender adds approximately 8 inches (200 mm) of length and may be used for either the driver or front passenger seating position. See

your INFINITI dealer for assistance if the extender is required.



## WARNING

- Only INFINITI belt extenders, made by the same company which made the original equipment belts, should be used with INFINITI belts.
- Adults and children who can use the standard seat belt should not use an extender. Such unnecessary use could result in serious personal injury in the event of an accident.
- Never use seat belt extenders to install child restraints. If the child restraint is not secured properly, the child could be seriously injured in a collision or a sudden stop.

### SEAT BELT MAINTENANCE

- To clean the seat belt webbings, apply a mild soap solution or any solution recommended for cleaning upholstery or carpets. Then brush the webbing, wipe it with a cloth and allow it to dry in the shade. Do not allow

the seat belts to retract until they are completely dry.

- If dirt builds up in the shoulder belt guide of the seat belt anchors, the seat belts may retract slowly. Wipe the shoulder belt guide with a clean, dry cloth.
- **Periodically check to see that the seat belt and the metal components** such as buckles, tongues, retractors, flexible wires and anchors work properly. If loose parts, deterioration, cuts or other damage on the webbing is found, the entire belt assembly should be replaced.

## CHILD RESTRAINTS

### PRECAUTIONS ON CHILD RESTRAINTS



#### WARNING

- **Infants and small children should always be placed in an appropriate child restraint while riding in the vehicle. Failure to use a child restraint can result in serious injury or death.**
- **Infants and small children should never be carried on your lap. It is not possible for even the strongest adult to resist the forces of a severe accident. The child could be crushed between the adult and parts of the vehicle. Also, do not put the same seat belt around both your child and yourself.**
- **Never install a rear facing child restraint in the front seat. An inflating supplemental air bag could seriously injure or kill your child. A rear facing child restraint must only be used in the rear seat.**

- **INFINITI recommends that the child restraint be installed in the rear seat. According to accident statistics, children are safer when properly restrained in the rear seat than in the front seat.**
- **An improperly installed child restraint could lead to serious injury or death in an accident.**

In general, child restraints are designed to be installed with the lap portion of a three-point type seat belt. In addition, this vehicle is equipped with a universal child restraint lower anchor system, referred to as the LATCH (Lower Anchors and Tethers for CHildren) system. Some child restraints include two rigid or webbing-mounted attachments that can be connected to these lower anchors. For details, see “LATCH (Lower Anchors and Tethers for CHildren) SYSTEM” later in this section.

Child restraints for infants and children of various sizes are offered by several manufacturers. When selecting any child restraint, keep the following points in mind:

- Choose only a restraint with a label certifying that it complies with Federal Motor

Vehicle Safety Standard 213 or Canadian Motor Vehicle Safety Standard 213.

- Check the child restraint in your vehicle to be sure it is compatible with the vehicle's seat and seat belt system.
- If the child restraint is compatible with your vehicle, place your child in the child restraint and check the various adjustments to be sure the child restraint is compatible with your child. Always follow all recommended procedures.

All US states and Canadian provinces require that infants and small children be restrained in approved child restraints at all times while the vehicle is being operated.



## WARNING

- Improper use of a child restraint can result in increased injuries for both the infant or child and other occupants in the vehicle.
- Follow all of the child restraint manufacturer's instructions for installation and use. When purchasing a child

restraint, be sure to select one which will fit your child and vehicle. It may not be possible to properly install some types of child restraints in your vehicle.

- If the child restraint is not anchored properly, the risk of a child being injured in a collision or a sudden stop greatly increases.
- Adjustable seatbacks should be positioned to fit the child restraint, but as upright as possible.
- After attaching the child restraint, test it before you place the child in it. Tilt it from side to side. Try to tug it forward and check to see if the belt holds the restraint in place. The child restraint should not move more than 1 in (25 mm). If the restraint is not secure, tighten the belt as necessary, or put the restraint in another seat and test it again.
- For a front facing child restraint, check to make sure the shoulder belt does not go in front of the child's face

or neck. If it does, put the shoulder belt behind the child restraint. If you must install a front facing child restraint in the front seat, see instructions later in this section.

- When your child restraint is not in use, store it in the trunk or keep it secured with a seat belt to prevent it from being thrown around in case of a sudden stop or accident.



## CAUTION

Remember that a child restraint left in a closed vehicle can become very hot. Check the seating surface and buckles before placing your child in the child restraint.



## INSTALLATION ON REAR SEAT OUTBOARD OR CENTER POSITIONS



### WARNING

- The three-point belt on your vehicle is equipped with a locking mode retractor which must be used when installing a child restraint.
- Failure to do so will result in the child restraint not being properly secured. It could tip over or otherwise be unsecured and cause injury to the child in a sudden stop or collision.

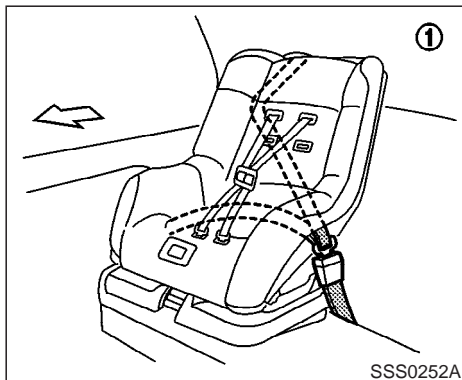

Front Facing (outboard) — step 1

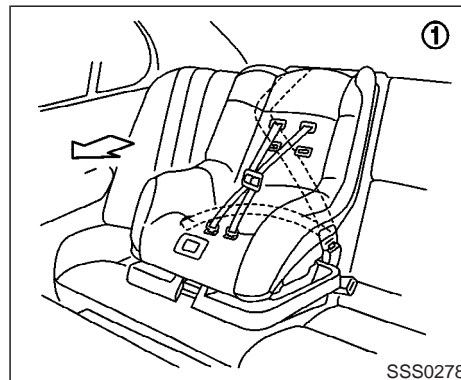

Front Facing (center) — step 1

### Front facing

When you install a child restraint in a rear outboard or center seat, follow these steps:

1. Position the child restraint on the seat. It can be placed in a front facing direction, depending on the size of the child. Adjust the head restraint to its highest position or remove it if the child restraint uses a top tether strap. Always follow the restraint manufacturer's instructions.

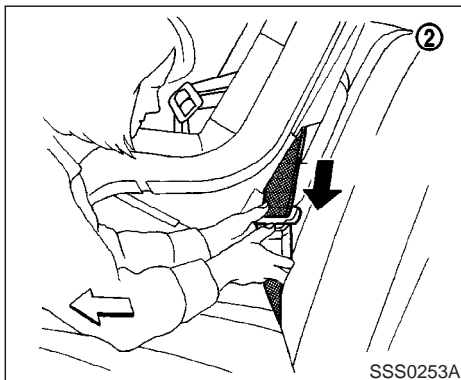

Front Facing — step 2

2. Route the seat belt tongue through the child restraint and insert it into the buckle until you hear and feel the latch engage. Be sure to follow the child restraint manufacturer's instructions for belt routing.

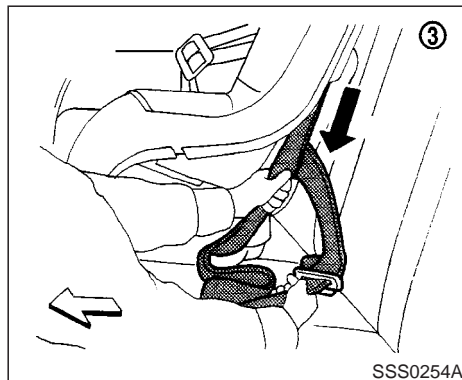

Front Facing — step 3

3. Pull on the shoulder belt until all of the belt is fully extended. At this time, the belt retractor is in the automatic locking mode (child restraint mode). It reverts back to emergency locking mode when the belt is fully retracted.

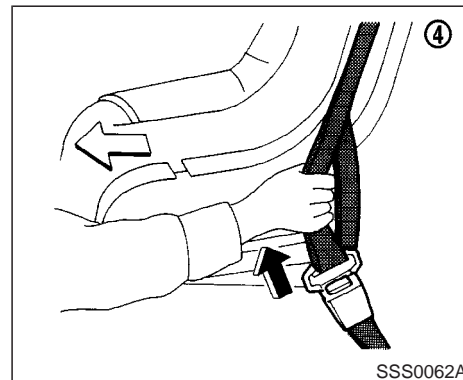

Front Facing — step 4

4. Allow the belt to retract. Pull up on the belt to remove any slack in the belt.

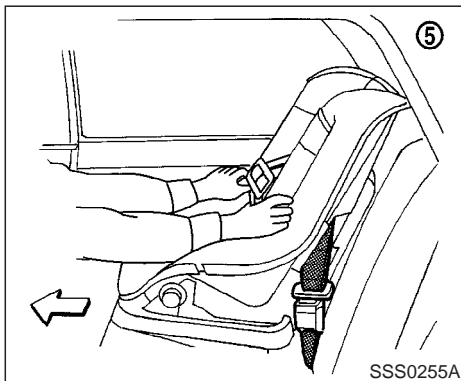

Front Facing — step 5

5. Before placing the child in the child restraint, use force to tilt the child restraint from side to side, and tug it forward to make sure that it is securely held in place. It should not move more than 1 in (25 mm).
6. Check that the retractor is in the automatic locking mode by trying to pull more belt out of the retractor. If you cannot pull any more belt webbing out of the retractor, the belt is in the automatic locking mode.
7. Check to make sure that the child restraint is properly secured prior to each use. If the belt is not locked, repeat steps 3 through 6.

After the child restraint is removed and the seat belt is allowed to wind back into the retractor, the automatic locking mode (child restraint mode) is canceled; the seat belt only locks during a sudden stop or impact.

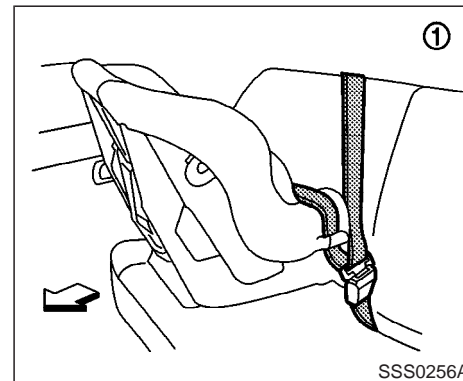

Rear Facing (outboard) — step 1

## Rear facing

When you install a child restraint in a rear outboard or center seat, follow these steps:

1. Position the child restraint on the seat. The direction of the child restraint depends on the type of the child restraint and the size of the child. Always follow the restraint manufacturer's instructions.

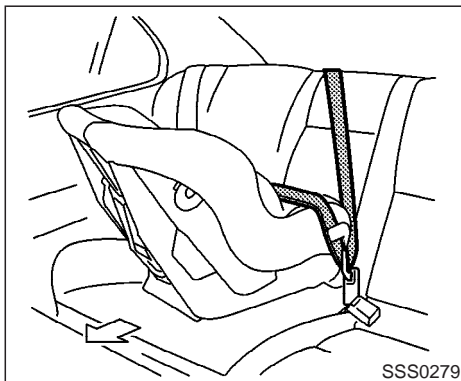

Rear Facing (center) — step 1

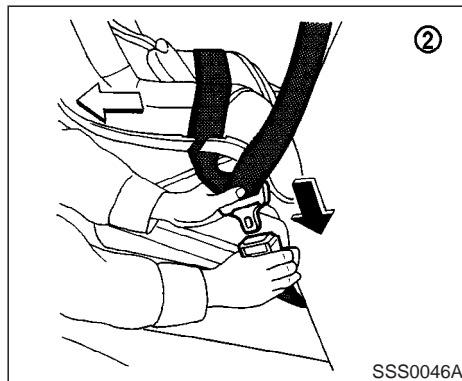

Rear Facing — step 2

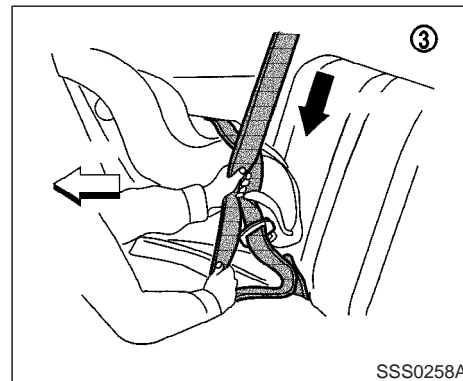

Rear Facing — step 3

2. Route the seat belt tongue through the child restraint and insert it into the buckle until you hear and feel the latch engage. Be sure to follow the child restraint manufacturer's instructions for belt routing.

3. Pull on the shoulder belt until all of the belt is fully extended. At this time, the belt retractor is in the automatic locking mode (child restraint mode). It reverts back to emergency locking mode when the belt is fully retracted.

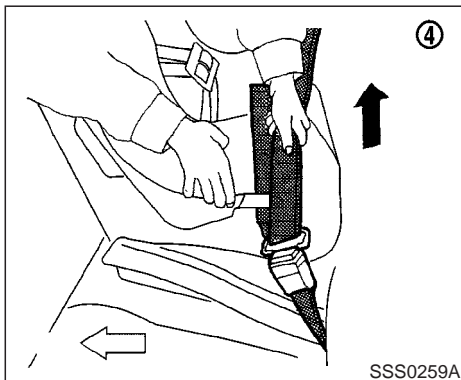

Rear Facing — step 4

4. Allow the belt to retract. Pull up on the belt to remove any slack in the belt.

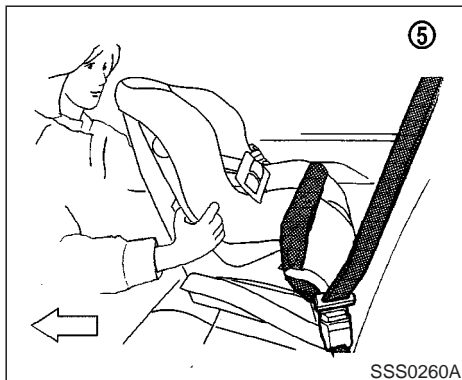

Rear Facing — step 5

5. Before placing the child in the child restraint, use force to tilt the child restraint from side to side, and tug it forward to make sure that it is securely held in place. It should not move more than 1 in (25 mm).
6. Check that the retractor is in the automatic locking mode by trying to pull more belt out of the retractor. If you cannot pull any more belt webbing out of the retractor, the belt is in the automatic locking mode.
7. Check to make sure that the child restraint is properly secured prior to each use. If the belt is not locked, repeat steps 3 through 6.

After the child restraint is removed and the seat belt is allowed to wind back into the retractor, the automatic locking mode (child restraint mode) is canceled; the seat belt only locks during a sudden stop or impact.

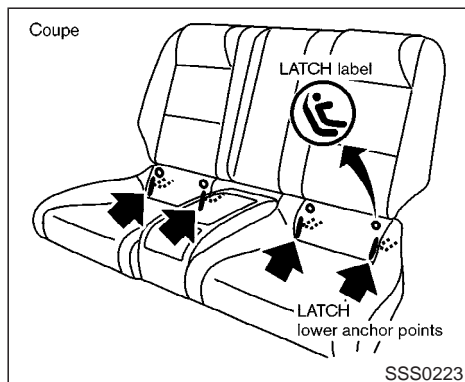
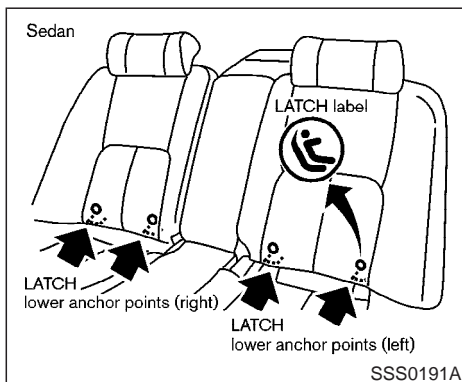

## LATCH (LOWER ANCHORS AND TETHERS FOR CHILDREN) SYSTEM



### WARNING

- Attach LATCH system compatible child restraints only at the locations shown. If a child restraint is not secured properly, your child could be seriously injured or killed in an accident.

- Do not secure a child restraint in the center rear seating position using the child restraint lower anchors. The child restraint will not be secured properly.
- The LATCH system anchors are designed to withstand only those loads imposed by correctly fitted child restraints. Under no circumstance are they to be used for adult seat belts or harnesses.

Some child restraints include two rigid or webbing-mounted attachments that can be

connected to two anchors located at certain seating positions in your vehicle. This system is known as the LATCH (Lower Anchors and Tethers for Children) system. This system may also be referred to as the ISOFIX or ISOFIX compatible system. With this system, you do not have to use a vehicle seat belt to secure the child restraint. Your vehicle is equipped with special anchor points that are used with LATCH system compatible child restraints. Check your child restraint for a label stating that it is compatible with the LATCH system. This information may also be in the child restraint owner's manual. If you have such a child restraint, refer to the illustration for the rear seating positions equipped with LATCH system anchors which can be used to secure the child restraint.

The LATCH system anchors are located at the rear of the seat cushion near the seatback. A label is attached to the seatback to help you locate the LATCH system anchors.

Some child restraints may also require the use of a top tether strap. See "Top tether strap child restraint" later in this section for installation instructions.

When installing a child restraint, carefully read and follow the instructions in this manual and those supplied with the child restraint.

When you install a LATCH system compatible child restraint to the lower anchor attachments in the rear seat, follow these steps.



## WARNING

Inspect the lower anchors by inserting your fingers into the lower anchor area and feeling to make sure there are no obstructions over the LATCH system anchors, such as seat belt webbing or seat cushion material. The child restraint will not be secured properly if the LATCH system anchors are obstructed.

1. To install the LATCH system compatible child restraint, adjust the height of the child restraint LATCH system anchor attachments to the anchor points on the rear seat.
2. Insert the anchor attachments into the anchor points. If the child restraint is equipped with a top tether, see “Top tether strap child restraint” later in this section for installation instructions.
3. After attaching the child restraint and before placing the child in it, use force to tilt the child restraint from side to side and tug it forward to make sure that the child restraint

is securely held in place. It should not move more than 1 in (25 mm).

4. Check to make sure that the child restraint is properly secured prior to each use.

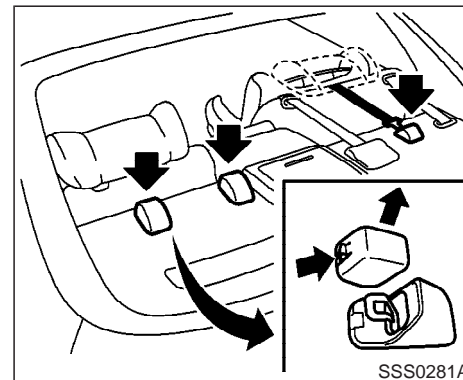

Sedan

## TOP TETHER STRAP CHILD RESTRAINT



## WARNING

- The child restraint anchor point is designed to withstand only those loads imposed by correctly fitted child restraints. Under no circumstance are they to be used for adult seat belts or harnesses.

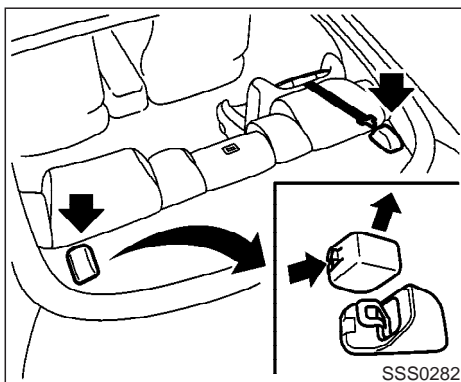

Coupe

SSS0282

- **After removing a rear seat head restraint for top tether installation, store it securely to prevent it from causing injury to passengers or damage to the vehicle in case of sudden braking or an accident. Always replace it and adjust properly when top tether is no longer in use.**

If your child restraint has a top tether strap, it must be secured to the anchor point provided behind its position.

First, adjust the seatback so that it is upright (if so equipped). Remove the anchor cover from

the anchor point as illustrated. Keep the removed cover in a secure place to prevent loss or damage. Then secure the child restraint with the rear seat belt or the LATCH system (outboard positions), as applicable.

Remove the head restraint from the seatback, if equipped with an adjustable rear head restraint. Store it in a secure place. Position the top tether strap over the top of the seatback and secure it to the tether anchor bracket that provides the straightest installation. Tighten the tether strap according to the manufacturer's instruction to remove any slack.

For best child restraint fit, see the child restraint installation instructions in this section and the child restraint manufacturer's instructions.

### Anchor point locations

Anchor points are located on the rear parcel shelf finisher.

**If you have any questions when installing a top strap child restraint on the rear seat, consult your INFINITI dealer for details.**



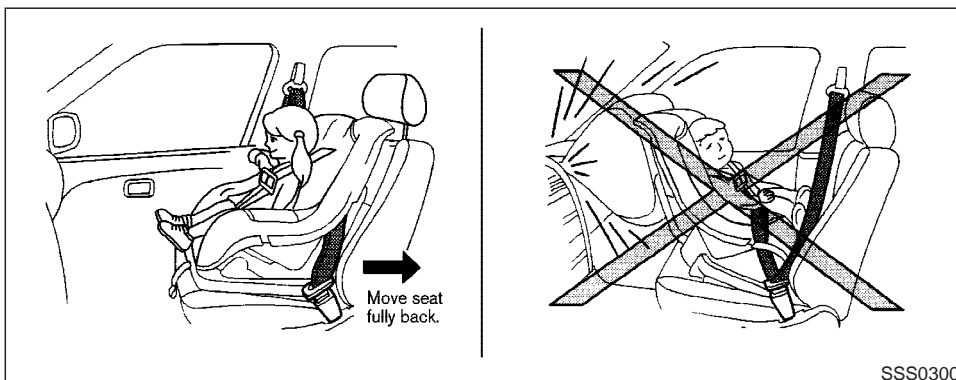

## INSTALLATION ON FRONT PASSENGER SEAT



### WARNING

- Never install a rear facing child restraint in the front passenger seat. Supplemental air bags inflate with great force. A rear facing child restraint could be struck by the supplemental air bag in a crash and could seriously injure or kill your child.

- INFINITI recommends that child restraints be installed in the rear seat. However, if you must install a front facing child restraint in the front passenger seat, move the passenger seat to the rearmost position.
- A child restraint with a top tether strap should not be used in the front passenger seat.
- The three-point belt in your vehicle is equipped with a locking mode retractor which must be used when install-

ing a child restraint.

- Failure to use the retractor's locking mode will result in the child restraint not being properly secured. The child restraint could tip over or otherwise be unsecured and cause injury to the child in a sudden stop or collision.

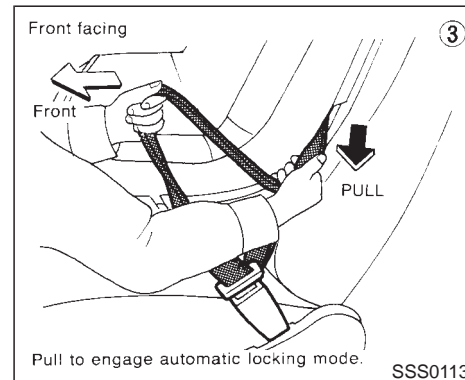
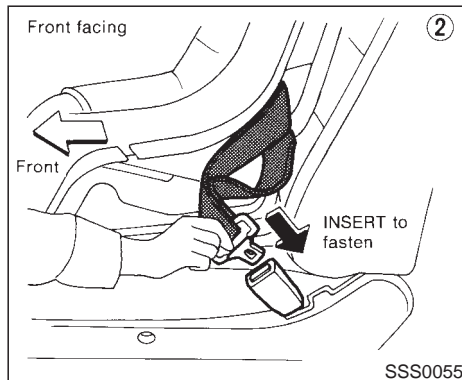
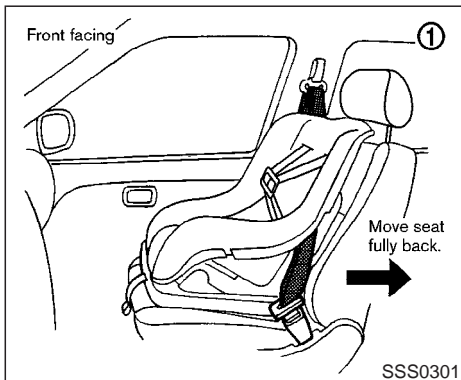

## Front facing

If you must install a child restraint in the front seat, follow these steps:

1. Position the child restraint on the front passenger seat. **It should be placed in a front facing direction only.** Move the seat to the rearmost position. Adjust the head restraint to its highest position. Always follow the child restraint manufacturer's instructions. **Child restraints for infants must be used in the rear facing direction and therefore must not be used in the front seat.**
2. Route the seat belt tongue through the child restraint and insert it into the buckle until you hear and feel the latch engage. Be sure to follow the child restraint manufacturer's instructions for belt routing.
3. Pull on the shoulder belt until all of the belt is fully extended. At this time, the belt retractor is in the automatic locking mode (child restraint mode). It reverts back to emergency locking mode when the belt is fully retracted.

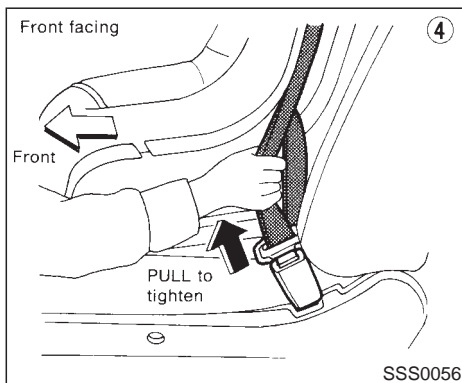

4. Allow the belt to retract. Pull up on the belt to remove any slack in the belt.

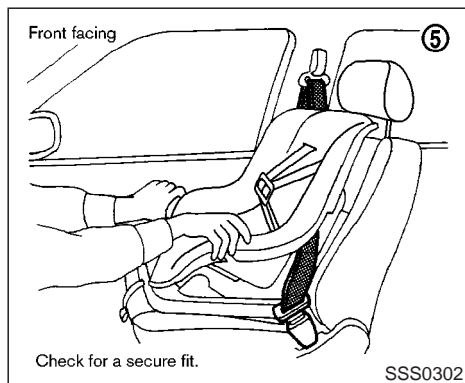

5. Before placing the child in the child restraint, use force to tilt the child restraint from side to side, and tug it forward to make sure that it is securely held in place. It should not move more than 1 in (25 mm).
6. Check that the retractor is in the automatic locking mode by trying to pull more belt out of the retractor. If you cannot pull any more belt webbing out of the retractor, the belt is in the automatic locking mode.
7. Check to make sure that the child restraint is properly secured prior to each use. If the lap belt is not locked, repeat steps 3 through 6.

After the child restraint is removed and the seat belt is allowed to wind back into the retractor, the automatic locking mode (child restraint mode) is canceled; the seat belt only locks during a sudden stop or impact.

## 2 Instruments and controls

Instrument panel .....	2-2	Horn.....	2-23
Meters and gauges .....	2-3	Heated seats (if so equipped).....	2-24
Speedometer and odometer .....	2-3	Snow mode switch (if so equipped).....	2-25
Tachometer .....	2-4	Vehicle dynamic control (VDC) off switch.....	2-25
Engine coolant temperature gauge.....	2-4	Clock .....	2-26
Fuel gauge .....	2-5	Adjusting the time.....	2-26
Compass display.....	2-6	Power outlet .....	2-26
Warning/indicator lights and audible reminders.....	2-9	Cigarette lighter and ashtray (accessory).....	2-27
Checking bulbs.....	2-9	Storage.....	2-28
Warning lights.....	2-9	Instrument pocket (Except for Navigation system equipped models).....	2-28
Indicator lights .....	2-12	Sunglasses holder .....	2-28
Audible reminders .....	2-14	Cup holder .....	2-29
Security systems .....	2-15	Glove box .....	2-30
Vehicle security system.....	2-15	Upper glove box (Except for Navigation system equipped models).....	2-31
INFINITI Vehicle Immobilizer System .....	2-16	Console box .....	2-31
Windshield wiper and washer switch.....	2-17	Rear armrest pocket.....	2-32
Rear window and outside mirror defroster switch .....	2-18	Card holder (driver's side).....	2-33
Headlight and turn signal switch.....	2-18	Coat hook (Coupe).....	2-33
Xenon headlights (if so equipped) .....	2-18	Stowing golf bags.....	2-33
Headlight switch .....	2-19	Windows .....	2-34
Turn signal switch .....	2-22	Power windows .....	2-34
Fog light switch .....	2-22	Automatic adjusting function (Coupe).....	2-36
Hazard warning flasher switch.....	2-23		

Sunroof (if so equipped) .....	2-37
Automatic sunroof .....	2-37
Interior light .....	2-39
Interior light.....	2-39
Map light.....	2-39
Rear personal light .....	2-40
Vanity mirror light (if so equipped).....	2-40
Trunk light .....	2-40
HomeLink® universal transceiver (if so equipped) .....	2-41

Programming HomeLink® .....	2-41
Programming HomeLink® for Canadian customers .....	2-43
Operating the HomeLink® universal transceiver .....	2-43
Programming trouble diagnosis.....	2-43
Clearing the programmed information.....	2-43
Reprogramming a single HomeLink® button.....	2-44
If your vehicle is stolen .....	2-44

## INSTRUMENT PANEL

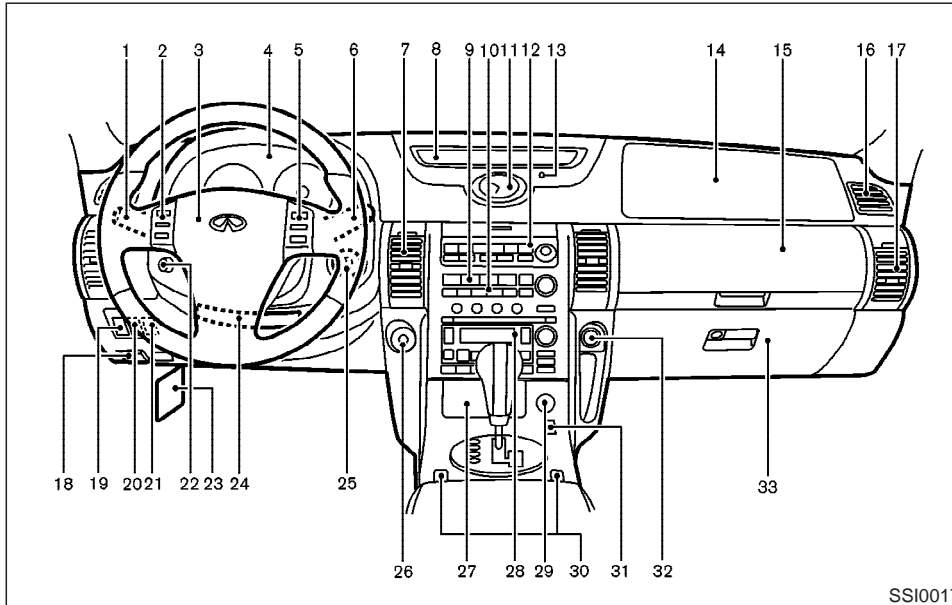

SSI0017

1. Headlight, fog light and turn signal switch
2. Steering switch for audio control
3. Driver supplemental air bag/Horn
4. Meters/gauges
5. Cruise control main/set switch
6. Windshield wiper/washer switch

7. Center ventilator
8. Center display - Compass, Air conditioner, Ambient temperature
9. Rear window and outside mirror (if so equipped) defogger switch
10. Heater/air conditioner control

11. Clock
12. Navigation system\* (if so equipped)
13. Security indicator
14. Passenger supplemental air bag
15. Upper glove box (Except for Navigation system equipped models)
16. Side window defogger
17. Side ventilator
18. Hood lock release handle
19. Instrument brightness control switch
20. Trunk lid release switch
21. VDC (Vehicle Dynamic Control) OFF switch
22. Outside mirror remote control
23. Fuse box
24. Tilting steering wheel lock lever
25. Ignition switch/steering lock
26. Cigarette lighter
27. Ashtray/Pocket
28. Radio/cassette player/CD player
29. Hazard warning flasher switch
30. Heated seat switch
31. Snow mode switch (if so equipped)
32. Power outlet
33. Glove box

\*: Refer to the separate Navigation System Owner's Manual.

## METERS AND GAUGES

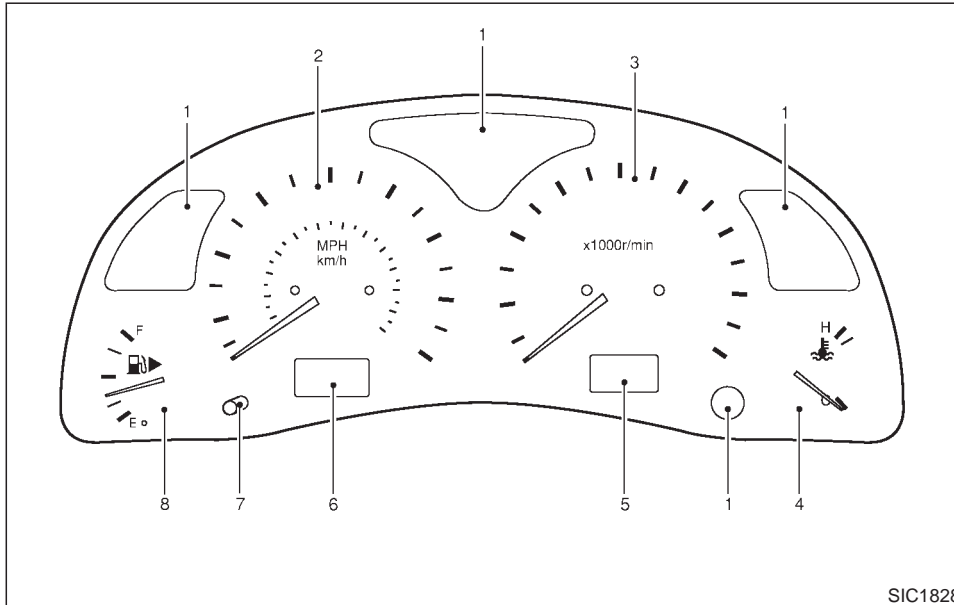

1. Warning/Indicator lights
2. Speedometer
3. Tachometer
4. Engine coolant temperature gauge
5. Automatic transmission position indicator
6. Odometer (Total/Twin trip)
7. Reset knob for twin trip odometer
8. Fuel gauge

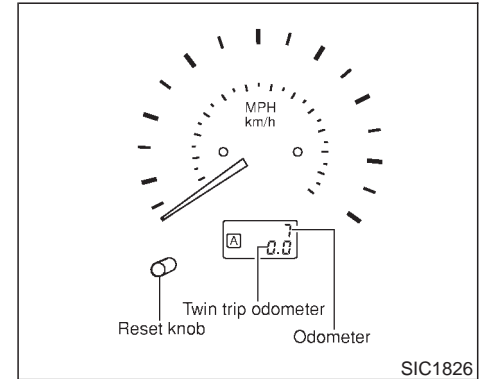

## SPEEDOMETER AND ODOMETER

### Speedometer

The speedometer indicates vehicle speed.

### Odometer/Twin trip odometer

The odometer/twin trip odometer are displayed when the ignition key is in the ON position.

The odometer records the total distance the vehicle has been driven.

The twin trip odometer records the distance of individual trips.

### Changing the display:

Pushing the reset knob changes the display as follows:

TRIP A → TRIP B → TRIP A

### Resetting the trip odometer:

Pushing the reset knob for more than 1 second resets the trip odometer to zero.

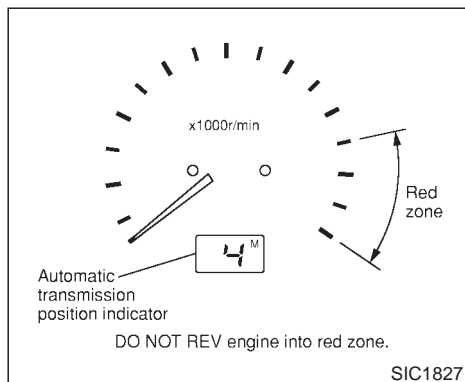

### TACHOMETER

The tachometer indicates engine speed in revolutions per minute (rpm).



### CAUTION

**When engine speed approaches the red zone, shift to a higher gear. Operating the engine in the red zone may cause serious engine damage.**

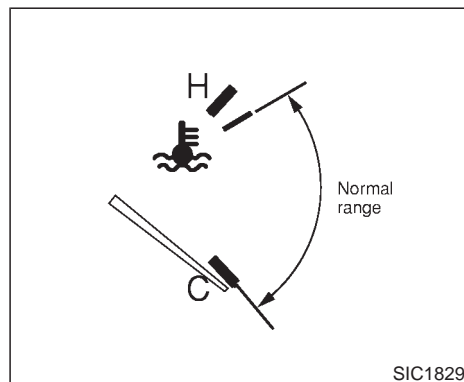

### ENGINE COOLANT TEMPERATURE GAUGE

The gauge indicates the engine coolant temperature.

The engine coolant temperature will vary with the outside air temperature and driving conditions.





## CAUTION

If the gauge indicates engine coolant temperature over the normal range, stop the vehicle as soon as safely possible. If the engine is overheated, continued operation of the vehicle may seriously damage the engine. See “If your vehicle overheats” in the “6. In case of emergency” section for immediate action required.

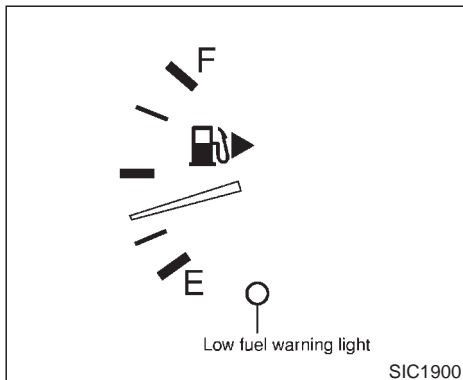

## FUEL GAUGE

The gauge indicates the approximate fuel level in the tank.

The gauge may move slightly during braking, turning, acceleration, or going up or down hill.

The gauge needle is designed to move to the E (Empty) position when the ignition key is turned to the OFF position.

**Refill the fuel tank before the gauge registers Empty.**

The low fuel warning light comes on when the fuel tank is getting low. Refuel as soon as it is convenient, preferably before the gauge reaches E. There will be a small reserve of fuel in the tank when the fuel gauge needle reaches E.

The  indicates that the fuel filler lid is located on the passenger's side of the vehicle.



## CAUTION

- If the vehicle runs out of fuel, the **SERVICE ENGINE SOON** malfunction indicator lamp (MIL) may come on. Refuel as soon as possible. After a few driving trips, the **SERVICE ENGINE SOON** lamp should turn off. If the lamp remains on after a few driving trips, have the vehicle inspected by an authorized INFINITI dealer.
- For additional information, see the “Malfunction indicator lamp (MIL)” later in this section.

## COMPASS DISPLAY

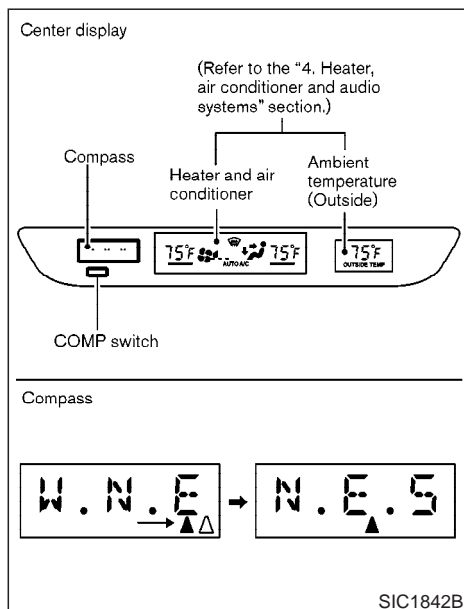

N: north

E: east

S: south

W: west

▲: vehicle direction

The above example shows the display changes from "East" to "East-southeast".

If the compass unit does not receive any correct signal for 10 minutes, the compass will display the bar "-- -- --". Have the vehicle inspected by an INFINITI dealer.

Push COMP switch to turn the display on or off when the ignition key is in the ON position. The heading direction will be displayed.

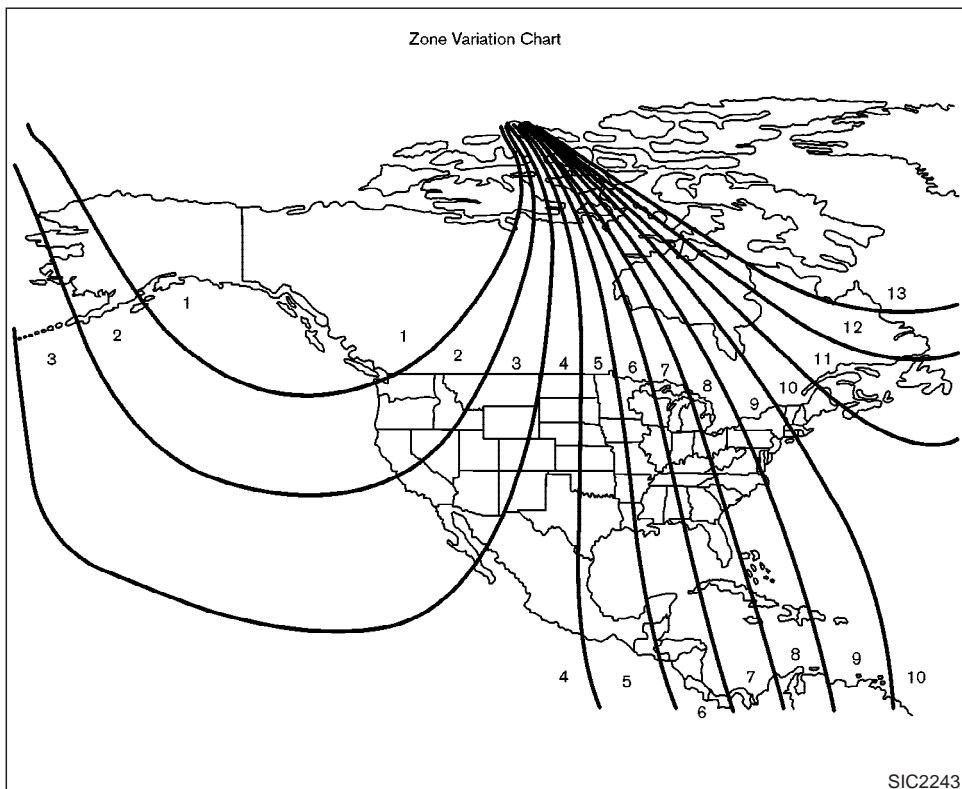

## Zone variation change procedure

The difference between magnetic north and geographical north is known as variance. In some areas, this difference can sometimes be great enough to cause false compass readings. Follow these instructions to set the variance for your particular location if this happens:

1. Establish your location on the zone map. Record your zone number.
2. Turn the ignition switch to the ON position while pressing the COMP switch.
3. Continue to press the COMP switch for more than 5 seconds until the current zone entry number is displayed on the compass.

If any operations are not carried out for more than 5 seconds, the display shows direction as normal.

4. Press COMP switch repeatedly until the new zone entry number is displayed.

Once the desired zone number is displayed, stop pressing the COMP switch and the display will show compass direction within a few seconds.

**If a magnet is located near the driver side instrument panel (the sensor is located inside) or the vehicle is driven where the terrestrial magnetism is disturbed, the compass display may not indicate the correct direction.**

- The compass may not display correctly at the following places:
  - under a bridge
  - among buildings
  - on an iron bridge
  - inside a tunnel
  - above a subway
  - on a railway crossing
  - in an underground parking lot
  - near a huge vehicle
  - near a transformer substation

If you carry out correction procedure at one of the above places, the procedure may not be completed correctly.

- If air conditioner fan speed is maximum, the compass display may shake. This is normal. Reduce the fan speed to avoid shaking the display.





















## Correction functions of the compass display

If the direction is not shown correctly, carry out correction procedure set out below.

## Correction procedure





1. Push COMP switch for about 10 seconds. The direction bar starts blinking.
2. Turn off electrical equipment such as lights, hazard indicator, air conditioner, etc. Then drive the vehicle slowly (less than 3 MPH (5 km/h)) and turn the vehicle one or more times in an open and safe area. When the compass displays the direction, the procedure is completed.

## WARNING/INDICATOR LIGHTS AND AUDIBLE REMINDERS





 <b>ABS</b> or 	Anti-lock brake warning light		Low washer fluid warning light		High beam indicator light (Blue)
 <b>AT CHECK</b>	Automatic transmission check warning light		Seat belt warning light	 <b>SERVICE ENGINE SOON</b>	Malfunction indicator lamp (MIL)
 <b>AWD</b>	AWD (All wheel drive) warning light (AWD models)		Supplemental air bag warning light	 <b>SLIP</b>	Slip indicator light
 <b>BRAKE</b> or 	Brake warning light	 <b>M</b>	Automatic transmission position indicator light	 <b>VDC OFF</b>	Vehicle dynamic control off indicator light
	Charge warning light	 <b>CRUISE</b>	Cruise main switch indicator light		Turn signal/hazard indicator lights
	Door open warning light		Low tire pressure warning light		
	Engine oil pressure warning light	 <b>SET</b>	Cruise set switch indicator light		

### CHECKING BULBS

Apply the parking brake and turn the ignition key to ON without starting the engine. The following lights will come on:

 , **BRAKE** OR  ,  ,  **SERVICE ENGINE SOON** , **AWD**

The following lights come on briefly and then go off:

 , **ABS** OR  , **SLIP** ,  **AT CHECK** ,  **VDC OFF** ,



If any light fails to come on, it may indicate a burned-out bulb or an open circuit in the elec-

trical system. Have the system repaired promptly.

### WARNING LIGHTS

 **ABS** or  Anti-lock brake warning light

If the light comes on while the engine is running, it may indicate the anti-lock brake system is not functioning properly. Have the system checked by your INFINITI dealer.

If an abnormality occurs in the system, the

anti-lock function will cease but the ordinary brakes will continue to operate normally.

**If the light comes on while you are driving, contact your INFINITI dealer for repair.**

 **AT CHECK** Automatic transmission check warning light

When the ignition switch is turned ON, the light comes on for 2 seconds. If the light blinks for approximately 8 seconds, it may indicate the automatic transmission system is not functioning properly. Have your INFINITI dealer check

and repair the transmission.

**AWD** AWD (All wheel drive) warning light (AWD models)

The **AWD** warning light comes on when the ignition switch is turned to ON. It turns off soon after the engine is started.

If the AWD system malfunctions, or the diameter of the front and the rear wheels are different, the warning light will either remain illuminated or blink. See “AWD warning light” in the “5. Starting and driving” section.



## CAUTION

- If the warning light comes on while driving there may be a malfunction in the AWD system. Reduce the vehicle speed and have your vehicle checked by an INFINITI dealer as soon as possible.
- Do not drive on dry, hard surface roads in the SNOW mode.
- If the AWD warning light blinks on when you are driving:

- **blinks rapidly (about twice a second):**  
**Pull off the road in a safe area, and idle the engine. The driving mode will change to 2WD to prevent the AWD system from malfunctioning. If the warning light turns off, you can drive again.**
- **blinks slowly (about once every 2 seconds):**  
**Pull off the road in a safe area, and idle the engine. Check that all tire sizes are the same, tire pressure is correct and tires are not worn.**

If the warning light is still on after the above operations, have your vehicle checked by an INFINITI dealer as soon as possible.

**BRAKE** or  Brake warning light

This light functions for both the parking brake and foot brake systems.

**Parking brake indicator:**

When the ignition key is in the ON position, the

light comes on when the parking brake is applied.

**Low brake fluid warning light:**

The light warns of a low brake fluid level. If the light comes on while the engine is running with the parking brake not applied, stop the vehicle and perform the following:

1. Check the brake fluid level. Add brake fluid as necessary. See “Brake fluid” in the “8. Maintenance and do-it-yourself” section.



## WARNING

- Your brake system may not be working properly if the warning light is on. Driving could be dangerous. If you judge it to be safe, drive carefully to the nearest service station for repairs. Otherwise, have your vehicle towed because driving it could be dangerous.
- Pressing the brake pedal with the engine stopped and/or low brake fluid level may increase your stopping distance and braking will require greater

pedal effort as well as greater pedal travel.

- If the brake fluid level is below the MIN mark on the brake fluid reservoir, do not drive until the brake system has been checked by an INFINITI dealer.

2. If the brake fluid level is correct, have the warning system checked by an INFINITI dealer.



### Charge warning light

If the light comes on while the engine is running, it may indicate that the charging system is not functioning properly. Turn the engine off and check the alternator belt. If the belt is loose, broken, missing or if the light remains on, see your INFINITI dealer immediately.



### CAUTION

Do not continue driving if the belt is loose, broken or missing.



### Door open warning light

This light comes on when any of the doors are not closed securely while the ignition key is ON.



### Engine oil pressure warning light

This light warns of low engine oil pressure. If the light flickers or comes on during normal driving, pull off the road in a safe area, stop the engine **immediately** and call an INFINITI dealer or other authorized repair shop.

**The engine oil pressure warning light is not designed to indicate a low oil level. Use the dipstick to check the oil level.** See “Engine oil” in the “8. Maintenance and do-it-yourself” section.



### CAUTION

**Running the engine with the engine oil pressure warning light on could cause serious damage to the engine almost immediately. Turn off the engine as soon as it is safe to do so.**



### Low washer fluid warning light

This light comes on when the washer tank fluid is at a low level. Add washer fluid as necessary. See “Window washer fluid” in the “8. Maintenance and do-it-yourself” section.



### Seat belt warning light and chime

The light and chime remind you to fasten seat belts. The light illuminates whenever the ignition key is turned to ON, and will remain illuminated until the driver's seat belt is fastened.

See “Seat belts” in the “1. Safety — Seats, restraints and supplemental air bags” section for precautions on seat belt usage.



### Supplemental air bag warning light

After turning the ignition key to the ON position, the supplemental air bag warning light will illuminate. The supplemental air bag warning light will turn off after about 7 seconds if the system is operational.

If any of the following conditions occur, the supplemental front air bag, supplemental side air bag and curtain side-impact air bag sys-

tems, and pre-tensioner seat belt need servicing and your vehicle must be taken to your nearest INFINITI dealer.

- The supplemental air bag warning light remains on after approximately 7 seconds.
- The supplemental air bag warning light flashes intermittently.
- The supplemental air bag warning light does not come on at all.

Unless checked and repaired, the Supplemental Restraint System and/or the pre-tensioner seat belt may not function properly. For additional information, see “Supplemental restraint system” in the “1. Safety — Seats, restraints and supplemental air bags” section.



## WARNING

If the supplemental air bag warning light is on, it could mean that the supplemental front air bag, supplemental side air bag and curtain side-impact air bag systems and/or pre-tensioner seat belt system will not operate in an accident.

## INDICATOR LIGHTS



### Automatic transmission position indicator light

When the ignition key is turned to the ON position, the indicator in the tachometer shows the automatic transmission selector lever position. See “Driving with automatic transmission” in the “5. Starting and driving” section.



### Cruise main switch indicator light

The light comes on when the cruise control main switch is pushed. The light goes out when the main switch is pushed again. When the cruise main switch indicator light comes on, the cruise control system is operational.



### Low tire pressure warning light

This light warns of low tire pressure.

INFINITI's low tire pressure warning system is a tire pressure monitoring system. It monitors tire pressure of all tires except the spare. When the tire pressure monitoring system warning light is lit, one or more of your tires is significantly under-inflated. You should stop and check your tires as soon as possible, and inflate them to the proper pressure as indi-

cated on the vehicle's tire information placard. Driving on a significantly under-inflated tire causes the tire to overheat and can lead to tire failure.

Under-inflation also reduces fuel efficiency and tire tread life, and may affect the vehicle's handling and stopping ability. Each tire, including the spare, should be checked monthly when cold and set to the recommended inflation pressure as specified in the vehicle placard and owner's manual.

The recommended inflation pressure may also be found on the Tire and Loading Information label.

### Low tire pressure warning:

If the vehicle is being driven with a very low tire pressure (lower than 25 psi: Sedan / 28 psi: Coupe), the light will illuminate and the chime will sound for about 10 seconds.

For additional information, see “Low tire pressure warning system” in the “5. Starting and driving” section and “Flat tire” in the “6. In case of emergency” section.





## WARNING

- If the light does not come on with the key switch turned ON, have the vehicle checked by an INFINITI dealer as soon as possible.
- If the light comes on while driving, avoid sudden steering maneuvers or abrupt braking, reduce vehicle speed, pull off the road to a safe location and stop the vehicle as soon as possible. Serious vehicle damage could occur and may lead to an accident and could result in serious personal injury. Check the tire pressure for all four tires. Adjust the tire pressure to the recommended COLD tire pressure shown on the Tire and Loading Information label to turn the low tire pressure warning light OFF. If the light still comes on while driving after adjusting the tire pressure, a tire may be flat. If you have a flat tire, replace it with a spare tire as soon as possible.

- When a spare tire is mounted or a wheel is replaced, the low tire pressure warning system will not function. Contact your INFINITI dealer as soon as possible for tire replacement and/or system resetting.



## CAUTION

- The low tire pressure warning system is not a substitute for the regular tire pressure check. Be sure to check the tire pressure regularly.
- If the vehicle is being driven at speeds of less than 20 MPH (32 km/h), the low tire pressure warning system may not operate correctly.
- Be sure to install the specified size of tires to the four wheels correctly.



Cruise set switch indicator light

The light comes on while the vehicle speed is controlled by the cruise control system. If the

light blinks while the engine is running, it may indicate the cruise control system is not functioning properly. Have the system checked by your INFINITI dealer.



High beam indicator light  
(Blue)

This light comes on when the headlight high beam is on and goes out when the low beam is selected.



Malfunction indicator lamp  
(MIL)

If the malfunction indicator lamp comes on steady or blinks while the engine is running, it may indicate a potential emission control malfunction.

The malfunction indicator lamp may also come on steady if the fuel filler cap is loose or missing, or if the vehicle runs out of fuel. Check to make sure the fuel filler cap is installed and closed tightly, and that the vehicle has at least three gallons (14 liters) of fuel in the fuel tank.

After a few driving trips, the  lamp should turn off if no other potential emission control system malfunction exists.

## Operation

The malfunction indicator lamp will come on in one of two ways:

- Malfunction indicator lamp on steady — An emission control system malfunction has been detected. Check the fuel filler cap. If the fuel filler cap is loose or missing, tighten or install the cap and continue to drive the vehicle. The **ENGINE SERVICE SOON** lamp should turn off after a few driving trips. If the **ENGINE SERVICE SOON** lamp does not turn off after a few driving trips, have the vehicle inspected by an authorized INFINITI dealer. You do not need to have your vehicle towed to the retailer.
- Malfunction indicator lamp blinking — An engine misfire has been detected which may damage the emission control system. To reduce or avoid emission control system damage:
  - a) Do not drive at speeds above 45 MPH (72 km/h).
  - b) Avoid hard acceleration or deceleration.
  - c) Avoid steep uphill grades.
  - d) If possible, reduce the amount of cargo being hauled or towed.

The malfunction indicator lamp may stop blinking and come on steady.

Have the vehicle inspected by an autho-

ri- rized INFINITI dealer. You do not need to have your vehicle towed to the retailer.



### CAUTION

**Continued vehicle operation without having the emission control system checked and repaired as necessary could lead to poor driveability, reduced fuel economy, and possible damage to the emission control system.**

### SLIP

#### Slip indicator light

This indicator will blink when the VDC system or the traction control system is operating, thus alerting the driver to the fact that the road surface is slippery and the vehicle is nearing its traction limits.



#### Vehicle dynamic control off indicator light

The light comes on when the vehicle dynamic control off switch is pushed to OFF. This indicates the vehicle dynamic control system and traction control system are not operating. When the vehicle dynamic control off indicator light and slip indicator light come on with the vehicle dynamic control system turned on, this

light alerts the driver to the fact that the vehicle dynamic control system's fail-safe mode is operating, i.e. the vehicle dynamic control system may not be functioning properly. Have the system checked by your INFINITI dealer. If an abnormality occurs in the system, the vehicle dynamic control system function will be canceled but the vehicle is still driveable. For additional information, see "Vehicle dynamic control system (VDC)" in the "5. Starting and driving" section of this manual.



#### Turn signal/hazard indicator lights

The light flashes when the turn signal switch lever or hazard switch is turned on.

## AUDIBLE REMINDERS

### Key reminder chime

The chime will sound if the driver's side door is opened while the key is left in the ignition switch (ignition switch is turned off). Remove the key and take it with you when leaving the vehicle.

### Light reminder chime

The chime will sound when the front door is opened with the headlight switch on unless the ignition key is in the ON position.

## SECURITY SYSTEMS

Make sure to turn the light switch off when you leave the vehicle.

### Brake pad wear warning

The disc brake pads have audible wear warnings. When a brake pad requires replacement, it will make a high pitched scraping sound when the vehicle is in motion whether or not the brake pedal is depressed. Have the brakes checked as soon as possible if the warning sound is heard.

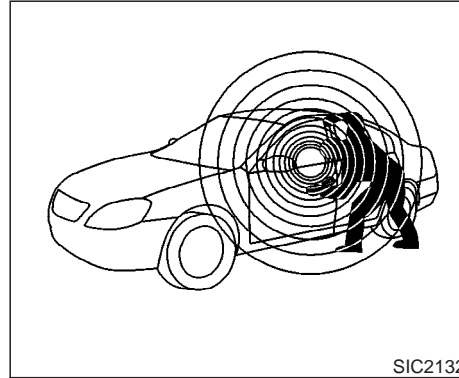

Your vehicle has two types of security systems, as follows:

- Vehicle Security System
- Infiniti Vehicle Immobilizer System

The security condition will be shown by the security indicator light.

### VEHICLE SECURITY SYSTEM

The vehicle security system provides visual and audio alarm signals if parts of the vehicle are disturbed.

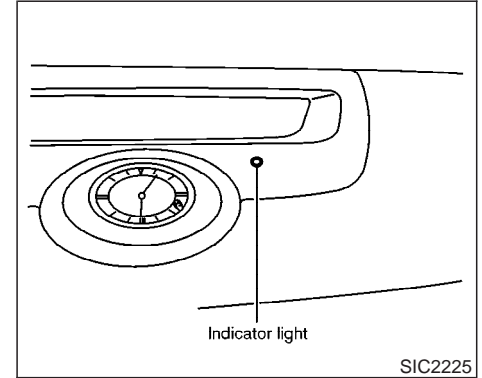

How to activate the vehicle security system

1. Close all windows.

**The system can be activated even if the windows are open.**

2. Remove the key from the ignition switch.
3. Close and lock all doors, hood and trunk lid.

Lock all doors by pressing the LOCK button on the keyfob. When using the keyfob, the hazard indicators flash twice to indicate all doors are locked.

4. Confirm that the SECURITY indicator light comes on. The SECURITY indicator light glows for about 30 seconds and then blinks. The system is now activated. If, during this 30 second time period, the door is unlocked by the key or the keyfob, or the ignition key is turned to ACC or ON, the system will not activate.

**Even when the driver and/or passengers are in the vehicle, the system will activate with all doors, hood and trunk lid locked and ignition key off. Turn the ignition key to ACC to turn off the system.**

### Vehicle security system operation

The security system will give the following alarm:

- The headlights blink and the horn sounds intermittently.
- The alarm automatically turns off after approximately 50 seconds. However, the alarm reactivates if the vehicle is tampered with again. The alarm can be shut off by unlocking a door with the key, or by pressing the UNLOCK button on the keyfob.

The alarm is activated by:

- Opening the door without using the key or keyfob.

- Opening the trunk lid without using the keyfob.
- Opening the hood.

### How to stop alarm

The alarm will stop only by unlocking a door with the key, or by pressing the UNLOCK button on keyfob. The alarm will not stop if the ignition switch is turned to ACC or ON.

**If the system does not operate as described above, have it checked by your INFINITI dealer.**

## INFINITI VEHICLE IMMOBILIZER SYSTEM

The Infiniti Vehicle Immobilizer System will not allow the engine to start without the use of the registered Infiniti Vehicle Immobilizer System key.

If the engine fails to start using the registered Infiniti Vehicle Immobilizer System key, it may be due to interference caused by another Infiniti Vehicle Immobilizer System key, an automated toll road device or automated payment device on the key ring. Restart the engine using the following procedures:

1. Leave the ignition switch in the ON position for approximately 5 seconds.

2. Turn the ignition switch to the OFF or LOCK position and wait approximately 10 seconds.
3. Repeat step 1 and 2 again.
4. Restart the engine while holding the device (which may have caused the interference) separate from the registered Infiniti Vehicle Immobilizer System key.

If this procedure allows the engine to start, INFINITI recommends placing the registered Infiniti Vehicle Immobilizer System key on a separate key ring to avoid interference from other devices.

**Statement related to section 15 of FCC rules for Infiniti Vehicle Immobilizer System (CONT ASSY-BCM, ANT ASSY-IMMOBILIZER)**

**This device complies with part 15 of the FCC Rules and RSS-210 of Industry Canada. Operation is subject to the following two conditions;**

**(1) This device may not cause harmful interference, and (2) this device must accept any interference received, including interference that may cause undesired operation of the device.**

**CHANGES OR MODIFICATIONS NOT EX-**

**PRESSLY APPROVED BY THE MANUFACTURE RESPONSIBLE FOR COMPLIANCE COULD VOID THE USER'S AUTHORITY TO OPERATE THE EQUIPMENT.**

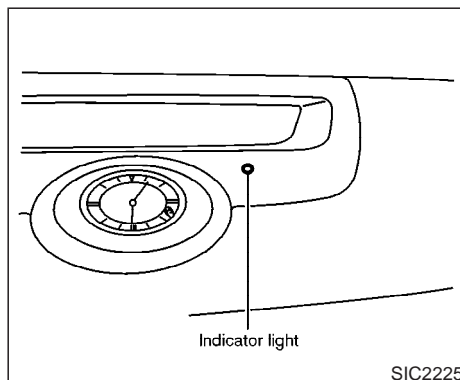

### Security indicator light

If Infiniti Vehicle Immobilizer System is malfunctioning, this light will remain on while the ignition key is in the ON position.

**If the light still remains on and/or the engine will not start, see your INFINITI dealer for Infiniti Vehicle Immobilizer System service as soon as possible. Please bring all Infiniti Vehicle Immobilizer System keys that you have when visiting your INFINITI dealer for service.**

## WINDSHIELD WIPER AND WASHER SWITCH

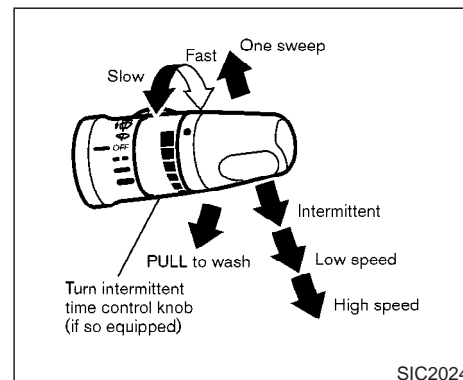

The windshield wiper and washer operates when the ignition key is in the ON position.

Push the lever down to operate the wiper.

Intermittent operation can be adjusted by turning the knob. Also, the intermittent operation speed varies in accordance with the vehicle speed. (e.g. When the vehicle speed is high, the intermittent operation speed will be faster.)

Pull the lever toward you to operate the washer. Then the wiper will also operate two times.



## WARNING

In freezing temperatures the washer solution may freeze on the windshield and obscure your vision which may lead to an accident. Warm the windshield with the defroster before you wash the windshield.



## CAUTION

The following could damage the washer system:

- Do not operate the washer continuously for more than 30 seconds.
- Do not operate the washer if the reservoir tank is empty.

## REAR WINDOW AND OUTSIDE MIRROR DEFROSTER SWITCH

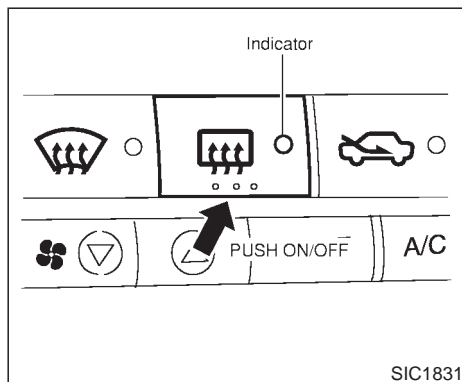

To defog/defrost the rear window glass and outside mirrors (if so equipped), start the engine and push the switch on. The indicator light will come on. Push the switch again to turn the defroster off.

It will automatically turn off in approximately 15 minutes.



## CAUTION

When cleaning the inner side of the rear window, be careful not to scratch or damage the rear window defroster.

## HEADLIGHT AND TURN SIGNAL SWITCH

XENON HEADLIGHTS (if so equipped)



## WARNING



## HIGH VOLTAGE

- When xenon headlights are on, they produce a high voltage. To prevent an electric shock, never attempt to modify or disassemble. Always have your xenon headlights replaced at an authorized INFINITI dealer.
- Xenon headlights provide considerably more light than conventional headlights. If they are not correctly aimed, they might temporarily blind an oncoming driver or the driver ahead of you and cause a serious accident. If headlights are not aimed correctly, immediately take your vehicle to an authorized INFINITI dealer and have the headlights adjusted correctly.

When the xenon headlight is initially turned on, its brightness or color varies slightly. However, the color and brightness will soon stabilize.

- The life of xenon headlights will be shortened by frequent on-off operation. It is generally desirable not to turn off the headlights for short intervals (for example, when the vehicle stops at a traffic signal). Even when the daytime running lights are active (Canada only), the xenon headlights do not turn on. This way the life of the xenon headlights is not reduced.
- If a xenon headlight bulb is close to burning out, the brightness will drastically decrease, the light will start blinking, or the color of the light will become reddish. If one or more of the above signs appear, contact an INFINITI dealer.

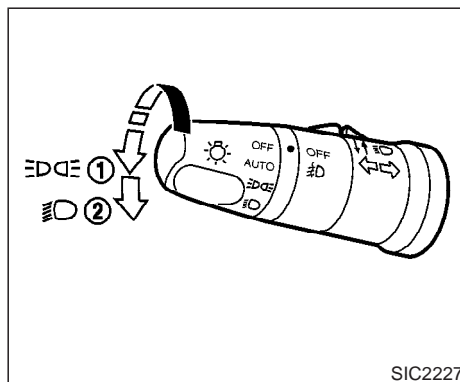

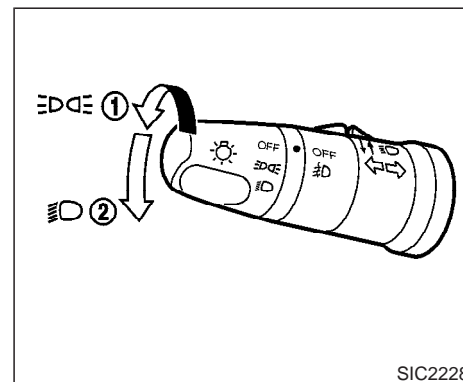

Type A



Type B

## HEADLIGHT SWITCH

### Lighting

- ① Turn the switch to the  position:  
The front park, side marker, tail, license plate and instrument lights will come on.
- ② Turn the switch to the  position:  
Headlights will come on and all the other lights remain on.

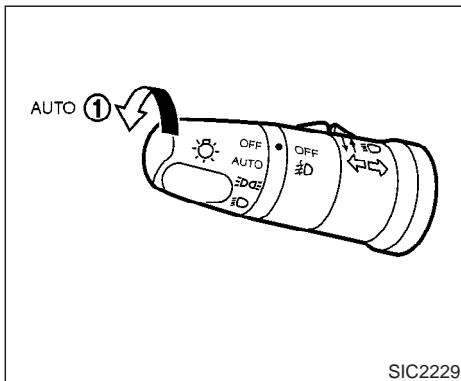

Autolight system

SIC2229

### Autolight system (if so equipped)

The autolight system allows the headlights to be set so they turn on and off automatically.

To set the autolight system:

Make sure the ignition key is in the ON position, and turn the headlight switch to the AUTO ① position.

The autolight system automatically turns the headlights on and off.

To cancel the autolight system:

Turn the switch to the OFF, , or  position.

## 2-20 Instruments and controls

The autolight system can turn on the headlights automatically when it is dark, turn off the headlights when it is light, and keep the headlights on for up to 45 seconds after you turn the key to OFF and open any door then close all the doors.

If the ignition switch is turned OFF and one of the doors is opened and this condition is continued, the headlights remain ON for five minutes.

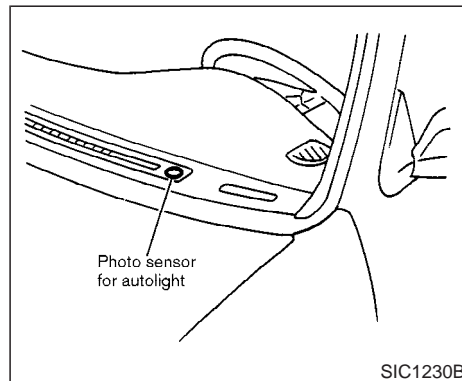

SIC1230B

**Be sure not to put anything on top of the photo sensor located on the top left-hand side of the instrument panel. The photo sensor controls the autolamp; if it is covered, the photo sensor reacts as if it is dark and the headlights will illuminate.**



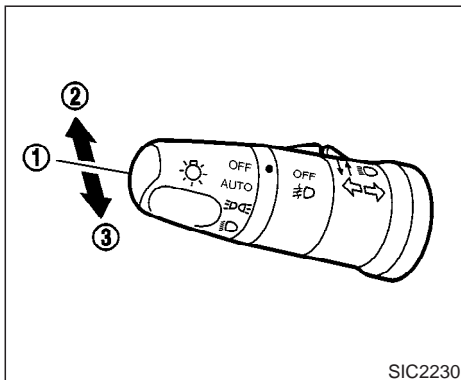

### Headlight beam select

- ① To select the low beam, put the lever in the neutral position as shown.
- ② To select the high beam, push the lever forward. Pull it back to select the low beam.
- ③ Pulling the lever toward you will flash the headlight high beam.

### Battery saver system

- When the headlight switch is in the  $\text{EDGE}$  or  $\text{HD}$  position while the ignition switch is in the ON position, the lights (including the front fog light) will automatically turn off 5 minutes after the ignition switch has been turned to the OFF position.
- When the headlight switch remains in the  $\text{EDGE}$  or  $\text{HD}$  position after the lights automatically turn off, the lights will turn on for 5 minutes when the headlight switch is turned to the OFF position and turn to the  $\text{EDGE}$  or  $\text{HD}$  position.



### CAUTION

- **Be sure to turn the light switch to the OFF position when you leave the vehicle for extended periods of time, otherwise the battery will go dead.**
- **Never leave the light switch on when the engine is not running for extended periods of time even if the headlights turn off automatically.**

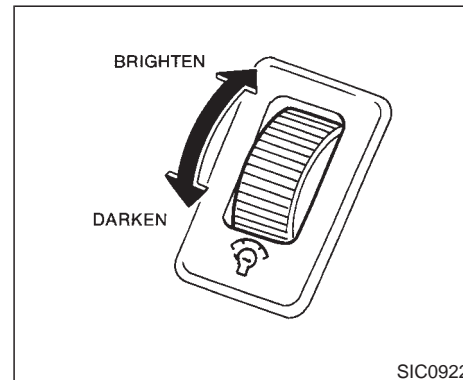



### Instrument brightness control

The instrument brightness control operates when the light switch is in the AUTO,  $\text{EDGE}$  or  $\text{HD}$  position.

Turn the control to adjust the brightness of instrument panel lights and clock (except power window switch lights). When the control is turned upward until it stops, the light intensity will be at maximum. When the control is turned downward until it stops, the light will be turned off.

## Daytime running light system (Canada only)

The headlights automatically illuminate at a reduced intensity when the engine is started with the parking brake released. The daytime running lights operate with the headlight switch in the OFF position or in the  position. Turn the headlight switch to the  position for full illumination when driving at night.

If the parking brake is applied before the engine is started, the daytime running lights do not illuminate. The daytime running lights illuminate once the parking brake is released. The daytime running lights will remain on until the ignition switch is turned off.



### WARNING

**When the daytime running light system is active, tail lights on your vehicle are not on. It is necessary at dusk to turn on your headlights. Failure to do so could cause an accident injuring yourself and others.**

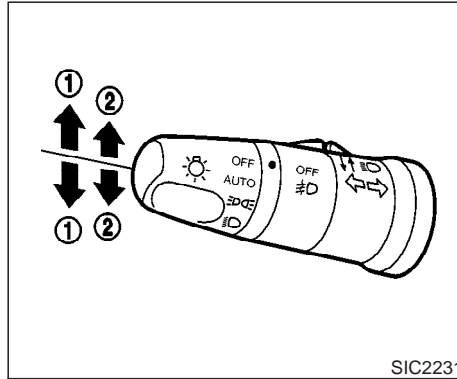

## TURN SIGNAL SWITCH

Turn signal

### ① Turn signal



Move the lever up or down to signal the turning direction. When the turn is completed, the turn signals cancel automatically.

### ② Lane change signal

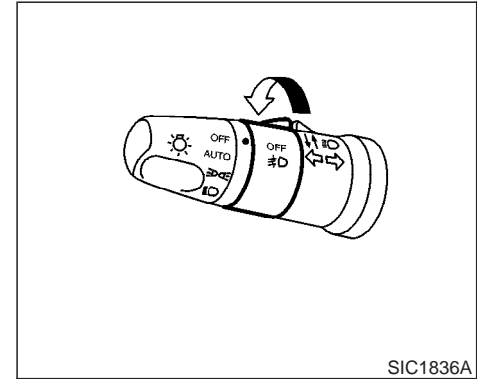
To indicate a lane change, move the lever up or down to the point where lights begin flashing.



## FOG LIGHT SWITCH

To turn the fog lights on, turn the headlight switch to the  position, then turn the switch to the  position. To turn them off, turn the switch to the OFF position.

The headlights must be on and the low beams selected for the fog lights to operate. The fog lights automatically turn off when the high beam headlights are selected.

## HAZARD WARNING FLASHER SWITCH

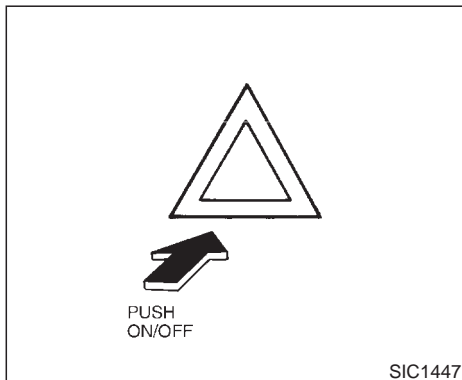

Push the switch on to warn other drivers when you must stop or park under emergency conditions. All turn signal lights will flash.

Some state or provincial laws may prohibit the use of the hazard warning flasher switch while driving.



### WARNING

- If stopping for an emergency, be sure to move the vehicle well off the road.

- Do not use the hazard warning flashers while moving on the highway unless unusual circumstances force you to drive so slowly that your vehicle might become a hazard to other traffic.
- Turn signals do not work when the hazard warning flasher lights are on.

The flasher can be actuated with the ignition switch either off or on.

## HORN

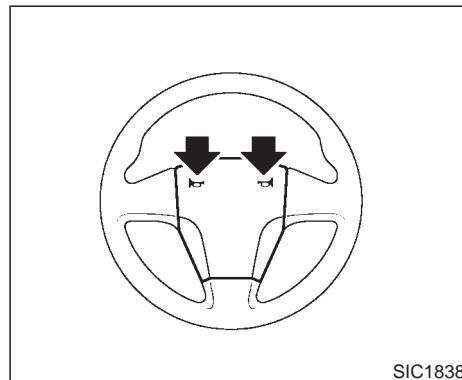

To sound the horn, push on or near the horn marks of the steering wheel.





### WARNING

Do not disassemble the horn. Doing so could affect proper operation of the supplemental front air bag system. Tampering with the supplemental front air bag system may result in serious personal injury.

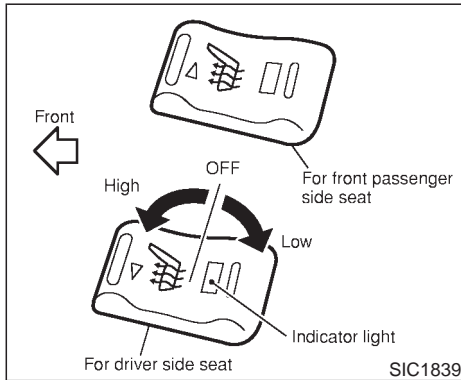
## HEATED SEATS (if so equipped)



The front seats are warmed by built-in heaters. The switches located on the center console can be operated independently of each other.

1. Start the engine.
2. Select heat range.
  - For low heat, press the  (Low) side of the switch.
  - For high heat, press the  (High) side of the switch.
  - For no heat, the switch has a center OFF position between low and high.

The indicator light in the switch will illumi-

nate when low or high is selected.

The heater is controlled by a thermostat, automatically turning the heater on and off. The indicator light will remain on as long as the switch is on.

3. When the vehicle's interior is warmed, or before you leave the vehicle, be sure to turn the switch to the off position (center).



### CAUTION

- The battery could run down if the seat heater is operated while the engine is not running.
- Do not use the seat heater for extended periods or when no one is using the seat.
- Do not put anything on the seat which insulates heat, such as a blanket, cushion, seat cover, etc. Otherwise, the seat may become overheated.
- Do not place anything hard or heavy on the seat or pierce it with a pin or similar object. This may result in damage to the heater.

- Any liquid spilled on the heated seat should be removed immediately with a dry cloth.
- When cleaning the seat, never use gasoline, thinner, or any similar materials.
- If any abnormalities are found or the heated seat does not operate, turn the switch off and have the system checked by your INFINITI dealer.

## SNOW MODE SWITCH (if so equipped)

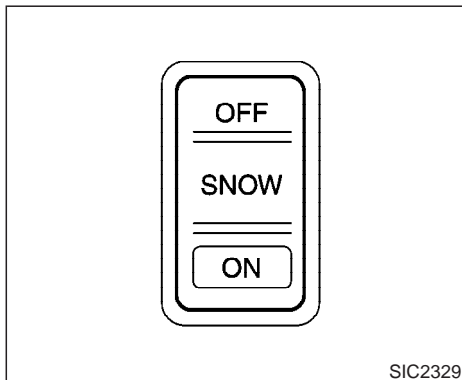

For driving or starting the vehicle on snowy roads or slippery areas, push the **SNOW** mode switch to the “ON” position and then the indicator light in the switch will illuminate. When the SNOW mode is activated, engine output is controlled to reduce wheel spin.



### CAUTION

When turning the vehicle in **SNOW** mode on paved roads, you may feel a braking effect. This is a normal condition of the AWD model.

## VEHICLE DYNAMIC CONTROL (VDC) OFF SWITCH

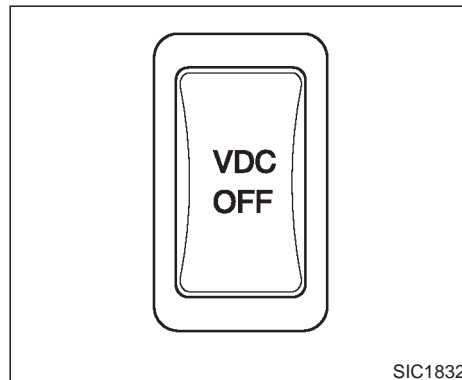

The vehicle should be driven with the Vehicle Dynamic Control (VDC) System ON for most driving conditions.

If the vehicle is stuck in mud or snow, the VDC system reduces the engine output to reduce wheel spin. The engine speed will be reduced even if the accelerator is depressed to the floor. If maximum engine power is needed to free a stuck vehicle, turn the VDC system off.

To cancel the Vehicle Dynamic Control System (VDC), push the VDC OFF switch to turn off the system. The **VDC OFF** indicator will come on.

Push the VDC OFF switch again or restart the engine to turn ON the system. See “Vehicle dynamic control system (VDC)” in the “5. Starting and driving” section.

## CLOCK

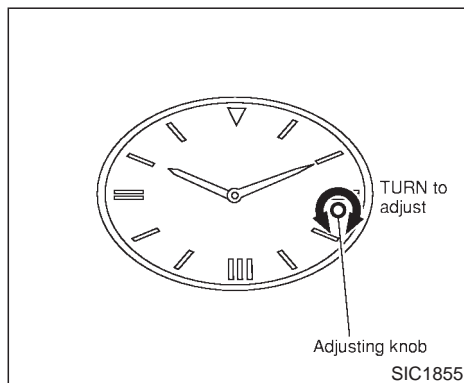

If the power supply is disconnected, the clock will not indicate the correct time. Readjust the time.

### ADJUSTING THE TIME

To adjust the time, turn the adjusting knob.

## POWER OUTLET

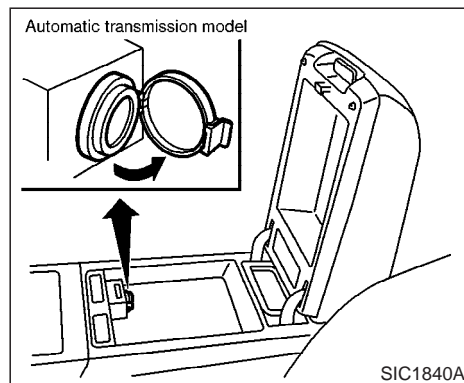

The power outlet is for powering electrical accessories such as cellular telephones.

### CAUTION

- Use caution as the socket and plug may be hot during or immediately after use.
- This power outlet is not designed for use with a cigarette lighter unit.
- Do not use with accessories that exceed a 12 volt, 120W (10A) power

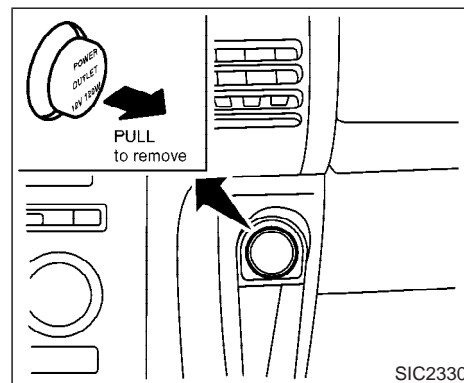

draw. Do not use double adapters or more than one electrical accessory.

- Use this power outlet with the engine running. (If the engine is stopped, this could result in a discharged battery.)
- Avoid using when the air conditioner, headlights or rear window defogger is on.
- Before inserting or disconnecting a plug, be sure to turn off the power

switch of the electrical accessory being used or the ACC power of the vehicle.

- Push the plug in as far as it will go. If good contact is not made, the plug may overheat or the internal temperature fuse may blow.
- When not in use, be sure to close the cap. Do not allow water to contact the socket.

## CIGARETTE LIGHTER AND ASHTRAY (accessory)

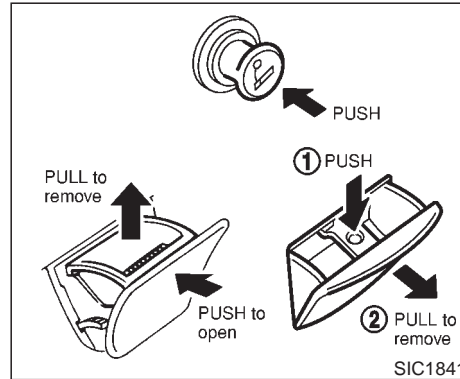

The cigarette lighter operates when the ignition switch is in the ACC or ON position.

Push the lighter in all the way. When the lighter is heated, it will spring out.

Return the lighter to its original position after use.



## WARNING

The cigarette lighter should not be used while driving so full attention may be given to vehicle operation.



## CAUTION

The cigarette lighter socket is a power source for the cigarette lighter element only. The use of the cigarette lighter socket as a power source for any other accessory is not recommended.

## STORAGE

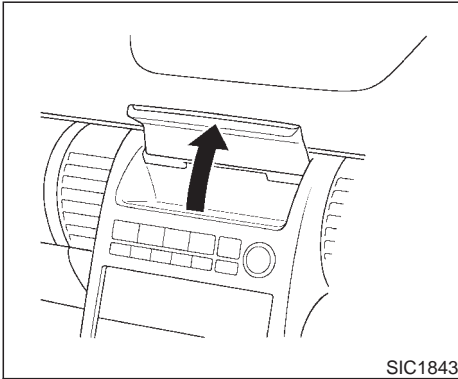

**INSTRUMENT POCKET** (Except for Navigation system equipped models)



### WARNING

The instrument pocket should not be used while driving so full attention may be given to vehicle operation.

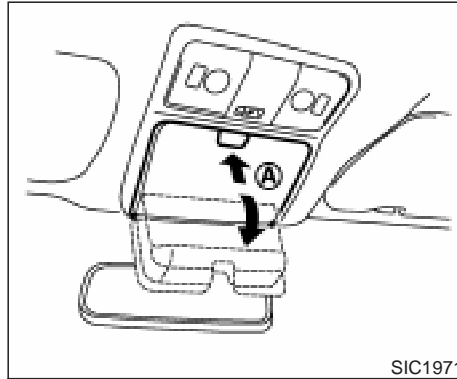

### SUNGLASSES HOLDER

The sunglasses holder can be opened by pushing the button (A).



### WARNING

- The sunglasses holder should not be used while driving so full attention may be given to vehicle operation.
- Keep the sunglasses holder closed while driving to prevent an accident.



### CAUTION

- Do not use for anything other than glasses.
- Do not leave glasses in the sunglasses holder while parking in direct sunlight. The heat may damage the glasses.



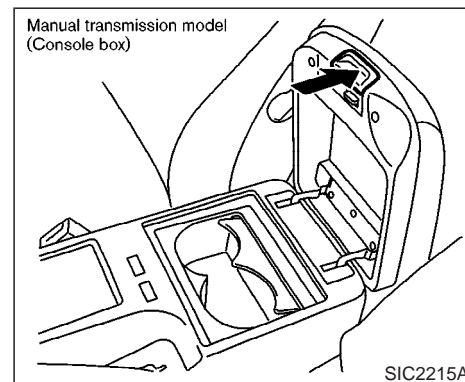
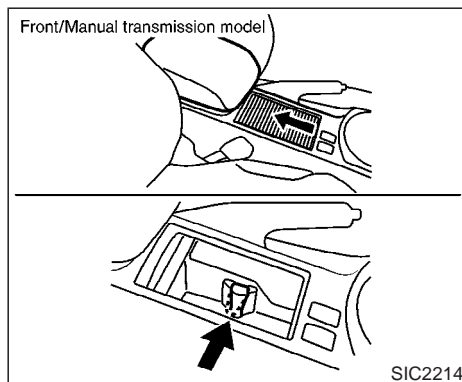
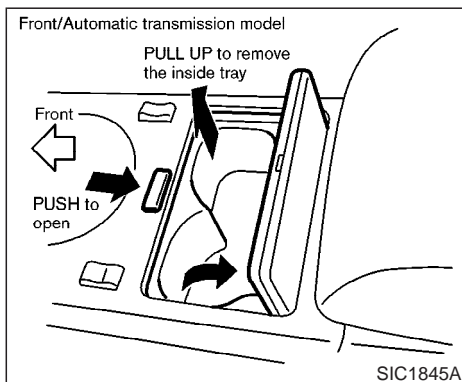

## CUP HOLDER



### WARNING

The cup holder should not be used while driving so full attention may be given to vehicle operation.

Front (Automatic transmission model):

For larger cups, remove the inside tray.

Front (Manual transmission model):

Slide the lid rearward and push the button of the stopper to set up.

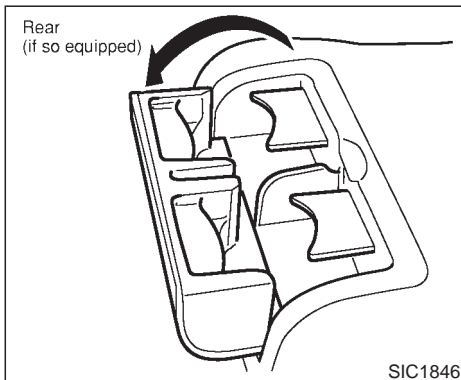

**⚠ CAUTION**

- Avoid abrupt starting and braking when the cup holder is being used to prevent spilling the drink. If the liquid is hot, it can scald you or your passenger.
- Use only soft cups in the cup holder. Hard objects can injure you in an accident.

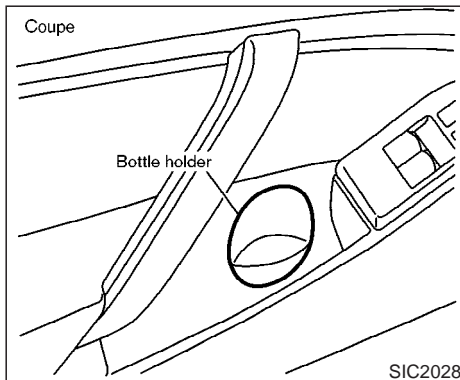

**Soft bottle holder**

**⚠ CAUTION**

The bottle holder should not be used while driving so full attention may be given to vehicle operation.

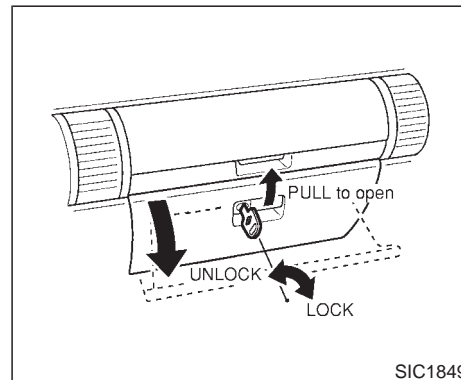

**GLOVE BOX**

When locking or unlocking the glove box, use the master key.

The glove box may be opened by pulling the handle.

**⚠ WARNING**

Keep glove box lid closed while driving to help prevent injury in an accident or a sudden stop.

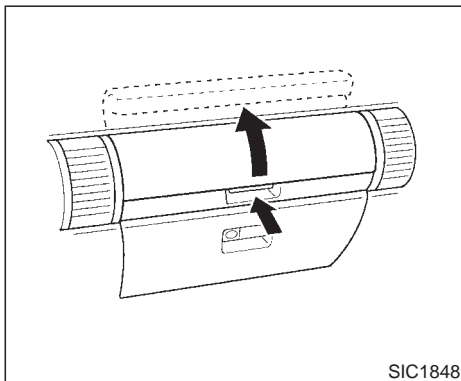

UPPER GLOVE BOX (Except for Navigation system equipped models)

**! WARNING**

Keep upper glove box lid closed while driving to help prevent injury in an accident or a sudden stop.

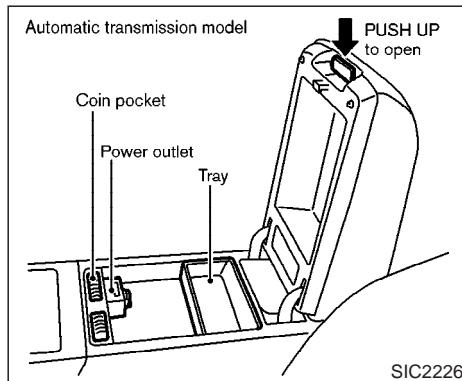

CONSOLE BOX

**! WARNING**

The center console box should not be used while driving so full attention may be given to vehicle operation.

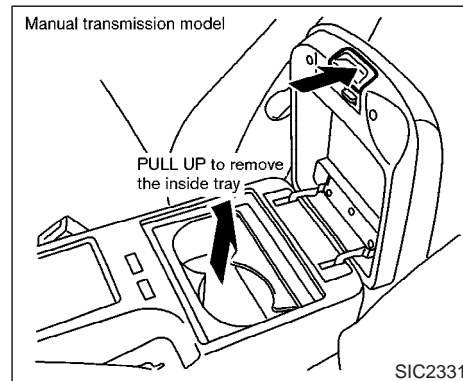

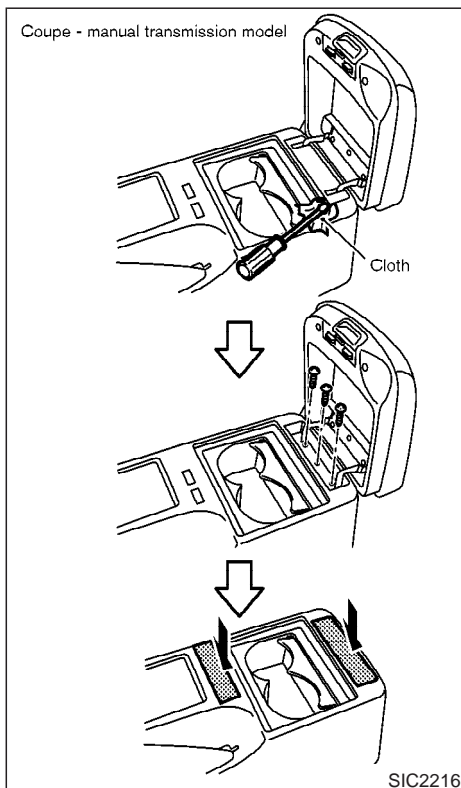

### Coupe (manual transmission model)

If you prefer comfortable shifter operation, remove the console lid.

1. Remove the original hinge mask. Attach a cloth when using a screw driver.
2. Loosen 3 screws, and remove the lid.
3. Install the replacement hinge mask and latch cover equipped with coupe manual transmission model.

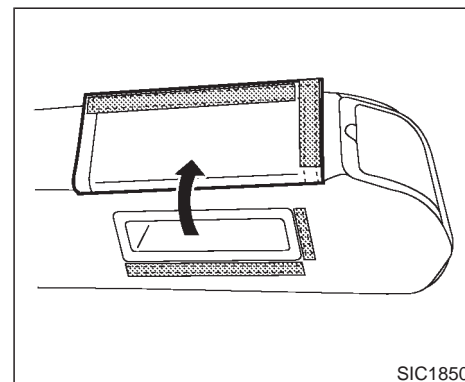

### REAR ARMREST POCKET

The pocket can store a first aid kit, etc.



**CAUTION**

**Do not use for heavy articles.**

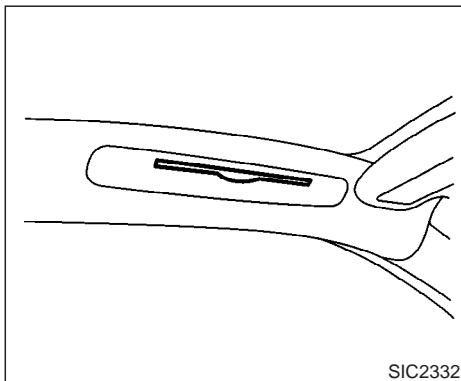

CARD HOLDER (Driver's side)



## WARNING

The card holder should not be used while driving so full attention may be given to vehicle operation.

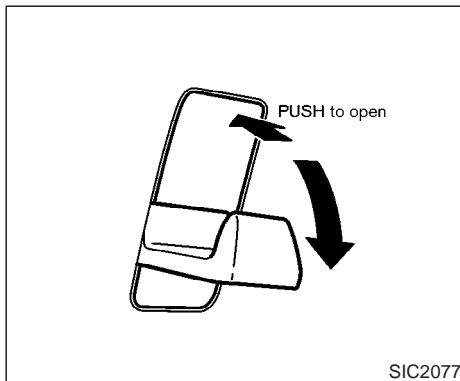

COAT HOOK (Coupe)



## CAUTION

Avoid hanging heavy goods on the hook.

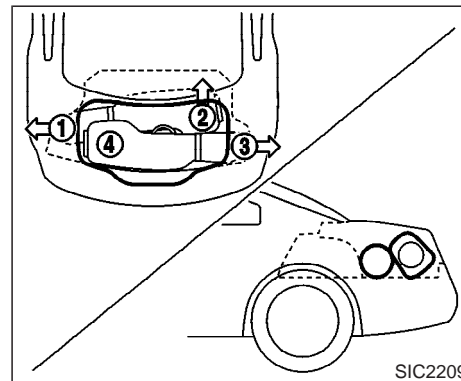

STOWING GOLF BAGS

Normally, two standard golf bags can be stowed in the trunk. Insert the top of the golf bag into left side of the trunk room (1) then put the bag forward (2). Insert the top of the 2nd golf bag into right side of the trunk room (3) and pull it in all the way (4).

Depending on their sizes, in some cases it may not be possible to store two golf bags.

## WINDOWS

### POWER WINDOWS



#### WARNING

- Make sure that all passengers have their hands, etc. inside the vehicle while it is in motion and before closing the windows. Use the window lock switch to prevent unexpected use of the power windows.
- Do not leave children unattended inside the vehicle. They could unknowingly activate switches or controls and become trapped in a window. Unattended children could become involved in serious accidents.

The power windows operate when the ignition key is in the ON position and for about 45 seconds, after the ignition key is turned to the OFF position. If the driver's door or the front passenger's door is opened during this period of about 45 seconds, power to the windows is canceled.

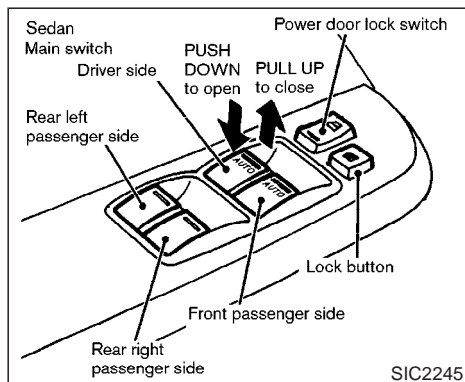

#### Main power window switch (driver's side)

To open or close the window, push down or pull up the switch and hold it. The main switch (driver side switches) will open or close all the windows.

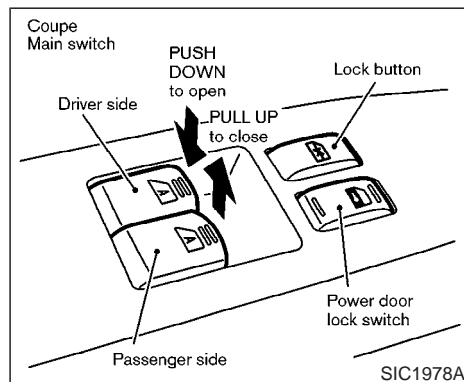

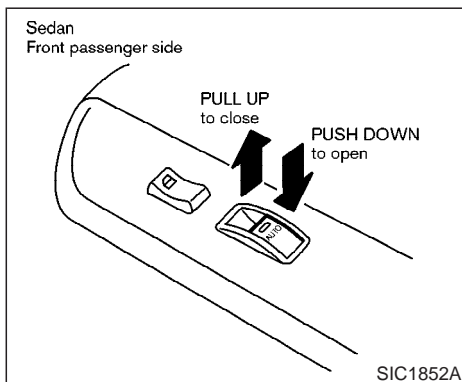

### Passenger side power window switch

The passenger side switch will open or close only the corresponding window. To open or close the window, hold the switch down or up.

### Locking passenger's windows

When the lock button is pushed in, only the driver side window can be opened or closed. Push it in again to cancel.

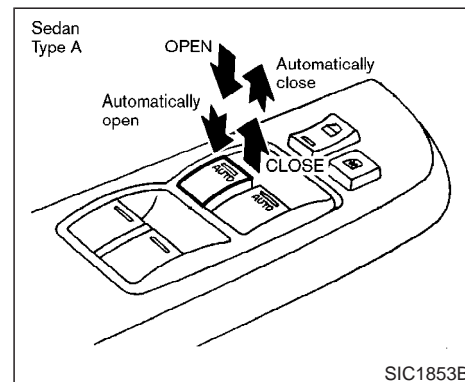
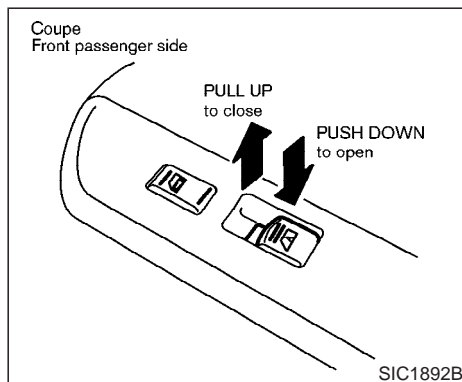

### Automatic operation (For front door windows or all door windows, if so equipped)

To fully open or close the window, completely press or lift the switch and release it; it need not be held. The window will automatically open or close all the way. To stop the window, just press or lift the switch in the opposite direction.

### Auto reverse function

If the control unit detects something caught in a window as it moves up, the window will be immediately lowered.

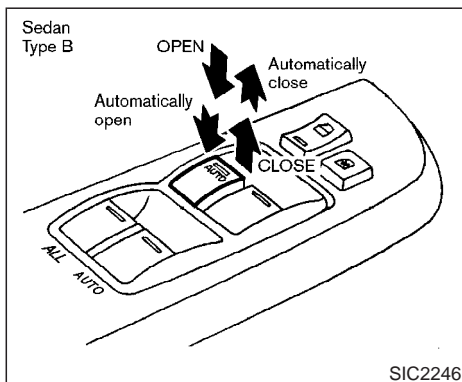

The auto reverse function can be activated when a window is closed by automatic operation when the ignition key is in the ON position, or for about 45 seconds after the ignition key is turned to the OFF position.

Depending on the environment or driving conditions, the auto reverse function may be activated if an impact or load similar to something being caught in the window occurs.

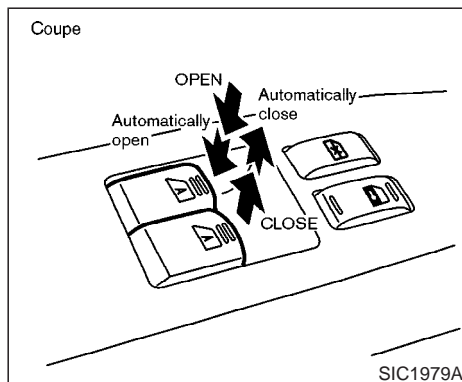

## WARNING

There are some small distances immediately before the closed position which cannot be detected. Make sure that all passengers have their hands, etc., inside the vehicle before closing the window.

## AUTOMATIC ADJUSTING FUNCTION (Coupe)



## CAUTION

When the battery cable is removed from the battery terminal, do not close either of the front doors. The automatic window adjusting function will not work, and the side roof panel may be damaged.

The power window has an automatic adjusting function. When the door is being opened, the window is automatically lowered slightly to avoid contact between the window and the side roof panel. When the door is closed, the window is automatically raised slightly.



## SUNROOF (if so equipped)

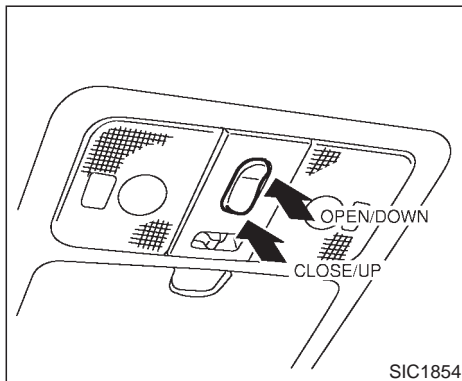

### AUTOMATIC SUNROOF

The sunroof will only operate when the ignition key is in the ON position.

The automatic sunroof is operational for about 45 seconds, even if the ignition key is turned to the OFF position. If the driver's door or the front passenger's door is opened during this period of about 45 seconds, power to the sunroof is canceled.

### Sliding the sunroof

To fully open or close the sunroof, press the switch to the CLOSE or OPEN side for less than 1 second and release it; it need not be

held. The roof will automatically open or close all the way. To stop the roof, press the switch once more while it is opening or closing.

To open or close the sunroof and stop on the way, press the switch to the CLOSE or OPEN side for more than 1 second. The roof will stop when releasing the switch.

### Auto reverse function (When closing the sunroof)

If the control unit detects something caught in the sunroof as it moves to the front, the sunroof will immediately open backward.

The auto reverse function can be activated when the sunroof is closed by automatic operation when the ignition key is in the ON position or for about 45 seconds after the ignition key is turned to the OFF position.

**Depending on the environment or driving conditions, the auto reverse function may be activated if an impact or load similar to something being caught in the sunroof occurs.**



### WARNING

**There are some small distances imme-**

**diately before the closed position which cannot be detected. Make sure that all passengers have their hands, etc., inside the vehicle before closing the sunroof.**

### Tilting the sunroof (Sedan)

To tilt up, first close the sunroof, then press and hold the UP side of the switch. To tilt down the sunroof, press and hold the DOWN side.

### Tilting the sunroof (Coupe)

To tilt up, first close the sunroof, then press the UP side of the switch and release it; it need not be held. To tilt down the sunroof, press the DOWN side.

### Sun shade

Open or close the sun shade by sliding it backward or forward.

The shade will open automatically when the sunroof is opened. However, it must be closed manually.



## WARNING

- In an accident you could be thrown from the vehicle through an open sunroof. Always use seat belts and child restraints.
- Do not allow anyone to stand up or extend any portion of their body out of the opening while the vehicle is in motion or while the sunroof is closing.



## CAUTION

- Remove water drops, snow, ice or sand from the sunroof before opening.
- Do not place any heavy object on the sunroof or surrounding area.

### If the sunroof does not close

If the sunroof does not close or open automatically, use the following procedure to return sunroof operation to normal.

#### Sedan:

1. Press the switch to the CLOSE/UP side to tilt up the sunroof. Release the switch when the sunroof is in the fully tilted up position.
2. Press and hold the switch to the CLOSE/UP side for approximately 10 seconds until the sunroof moves automatically.  
Continue to press and hold the switch while the sunroof operates automatically. Do not release the switch.
3. Release the switch when the sunroof stops.
4. If the sunroof does not operate properly after step 4, repeat the procedure starting with step 1.

#### Coupe:

1. Press the switch to the CLOSE/UP side to tilt up the sunroof.
2. Release the switch when the sunroof is in the fully tilted up position.
3. Press and hold the switch to the CLOSE/UP side for approximately 10 seconds until the sunroof automatically closes.
4. Release the switch when the sunroof stops.
5. Press and hold the switch to the CLOSE/UP side for approximately 4 sec-

onds until the sunroof moves automatically.

Continue to press and hold the switch while the sunroof operates automatically. Do not release the switch.

6. Release the switch when the sunroof stops.
7. If the sunroof does not operate properly after step 6, repeat the procedure starting with step 1.

Have your INFINITI dealer check and repair the sunroof.

## INTERIOR LIGHT

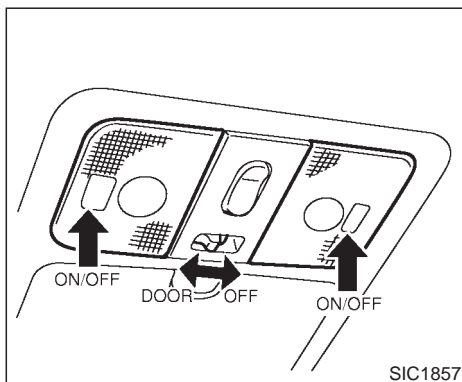

## INTERIOR LIGHT

The interior light has a two-position switch.

When the switch is in the door position, the light will illuminate when a door is opened.

The light will stay on for about 30 seconds when:

- The doors are unlocked by the keyfob, a key or the power door lock switch while all doors are closed.
- The driver's door is opened and then closed while the key is removed from the ignition switch.

- The key is removed from the ignition switch while all doors are closed.

The light will turn off while the 30 second timer is activated, when:

- The driver's door is locked either with the keyfob, a key or the power door lock switch.
- The ignition switch is turned ON.

## MAP LIGHT

When the switch is pushed in, the light will turn on. When the switch is pushed again, the light will turn off.

**When the map light switch is in the ON position, it will automatically turn off 30 minutes after the ignition switch has been turned to the OFF position. To turn on the light again, turn the ignition switch to the ON position.**

The map, personal, and vanity mirror lights will automatically turn off 30 minutes after the latest operation of the following with the ignition switch in the ACC or OFF position:

- Opening or closing any door
- Locking or unlocking with the keyfob, a key or the power door lock switch.
- Inserting or removing a key from the ignition switch

These lights will turn on again when any of the above operations is performed after the lights have turned off automatically. (The lights will turn off 30 minutes after the latest operation of the above as well.)



## CAUTION

- Turn off the map, personal and vanity mirror lights when you leave the vehicle.
- Do not use for extended periods of time with the engine stopped. This could result in a discharged battery.

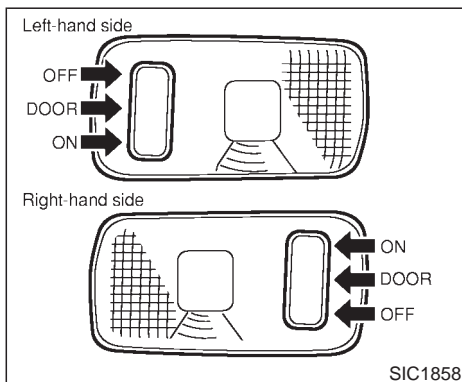

## REAR PERSONAL LIGHT

The rear personal light has a three-position switch.

When the switch is in the door position, the light will illuminate when the door is opened.

**When the personal light switch is in the ON position, it will automatically turn off 30 minutes after the ignition switch has been turned to the OFF position. To turn on the light again, turn the ignition switch to the ON position.**

## VANITY MIRROR LIGHT (if so equipped)

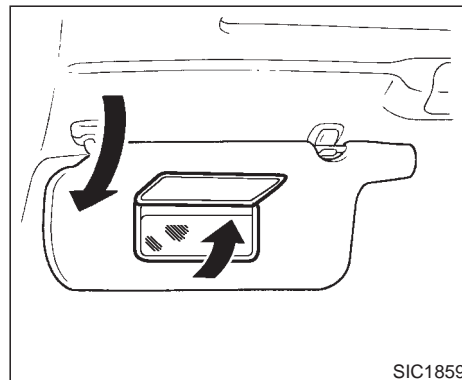

The light on the vanity mirror will turn on when the cover on the vanity mirror is opened.

**When the vanity mirror light stays on, it will automatically turn off 30 minutes after the ignition switch has been turned to the OFF position. To turn on the light again, turn the ignition switch to the ON position.**

## TRUNK LIGHT

The light illuminates when the trunk lid is opened. When the trunk lid is closed, the light will go off.

When the trunk light stays on, it will automatically turn off 30 minutes after the ignition switch has been turned to the OFF position. To turn on the light again, turn the ignition switch to the ON position.

## HomeLink<sup>®</sup> UNIVERSAL TRANSCIVER (if so equipped)

The HomeLink<sup>®</sup> Universal Transceiver provides a convenient way to consolidate the functions of up to three individual hand-held transmitters into one built-in device.

HomeLink<sup>®</sup> Universal Transceiver:

- Will operate most Radio Frequency (RF) devices such as garage doors, gates, home and office lighting, entry door locks and security systems.
- Is powered by your vehicle's battery. No separate batteries are required. If the vehicle's battery is discharged or is disconnected, HomeLink<sup>®</sup> will retain all programming.

**Once the HomeLink<sup>®</sup> Universal Transceiver is programmed, retain the original transmitter for future programming procedures (i.e., new vehicle purchases). Upon sale of the vehicle, the programmed HomeLink<sup>®</sup> Universal Transceiver buttons should be erased for security purposes. For additional information, refer to "Programming HomeLink<sup>®</sup>" later in this section.**



### WARNING

- **Do not use the HomeLink<sup>®</sup> Universal Transceiver with any garage door opener that lacks safety stop and reverse features as required by federal safety standards. (These standards became effective for opener models manufactured after April 1, 1982). A garage door opener which cannot detect an object in the path of a closing garage door and then automatically stop and reverse, does not meet current federal safety standards. Using a garage door opener without these features increases the risk of serious injury or death.**
- **During programming, your garage door or gate may open or close. Make sure that people and objects are clear of the garage door or gate that you are programming.**
- **Your vehicle's engine should be turned off while programming the HomeLink<sup>®</sup> Universal Transceiver.**

## PROGRAMMING HomeLink<sup>®</sup>

To program your HomeLink Transceiver to operate a garage door, gate, or entry door opener, home or office lighting, you need to be at the same location as the device. Note: Garage door openers (manufactured after 1996) have "rolling code protection". To program a garage door opener equipped with "rolling code protection"; you will need to use a ladder to get up to the garage door opener motor to be able to access the "smart or learn" program button.

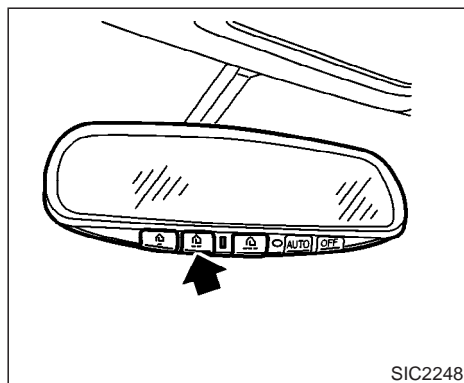
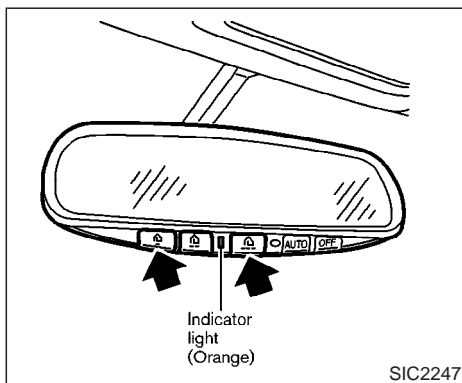

1. To begin, press and hold the 2 outer HomeLink<sup>®</sup> buttons (to clear the memory) until the indicator light blinks slowly (after 20 seconds). Release both buttons.
2. Position the end of the hand-held transmitter 1-3 inches away from the HomeLink<sup>®</sup> surface.

3. Using both hands, simultaneously press and hold both the HomeLink<sup>®</sup> button you want to program and the hand-held transmitter button.  
DO NOT release the buttons until step 4 has been completed.

4. Hold down both buttons until the indicator light on the HomeLink<sup>®</sup> flashes, changing from a “slow blink” to a “rapidly flashing blink”. This could take up to 90 seconds. When the indicator light flashes rapidly, both buttons may be released. The rapidly flashing light indicates successful programming. To activate the garage door or other programmed device, press and hold the

programmed HomeLink<sup>®</sup> button - releasing when the device begins to activate.

5. If the indicator light on the HomeLink<sup>®</sup> blinks rapidly for two seconds and then turns solid, HomeLink<sup>®</sup> has picked up a “rolling code” garage door opener signal. You will need to proceed with the next steps to train the HomeLink<sup>®</sup> to complete the programming which may require a ladder and another person for convenience.
6. Press and release the “smart” or “learn” program button located on the garage door opener’s motor to activate the “training mode”. This button is usually located near the antenna wire that hangs down from the motor. If the wire originates from under a light lens, you will need to remove the lens to access the program button.

#### NOTE:

**Once you have pressed and released the program button on the garage door opener’s motor and the “training light” is lit, you have 30 seconds in which to perform step 7. Use the help of a second person for convenience to assist when performing this step.**

7. Quickly within 30 seconds of pressing and releasing the garage door opener program

button, firmly press and release the HomeLink<sup>®</sup> button you've just programmed. Press and release the HomeLink<sup>®</sup> button up to three times to complete the training.

8. Your HomeLink<sup>®</sup> button should now be programmed. (To program the remaining HomeLink<sup>®</sup> buttons for additional door or gate openers, follow steps 2-8 only.)

#### **NOTE:**

**Do not repeat step one unless you want to “clear” all previously programmed HomeLink<sup>®</sup> buttons).**

If you have any questions or are having difficulty programming your HomeLink<sup>®</sup> buttons, please refer to the HomeLink<sup>®</sup> web site at: [www.homelink.com](http://www.homelink.com) or call 1-800-662-6200.

### **PROGRAMMING HomeLink<sup>®</sup> FOR CANADIAN CUSTOMERS**

Prior to 1992, D.O.C. regulations required hand-held transmitters to stop transmitting after 2 seconds. To program your hand-held transmitter to HomeLink<sup>®</sup>, continue to press and hold the HomeLink<sup>®</sup> button (note steps 2 through 4 under “Programming HomeLink<sup>®</sup>”) while you press and re-press (“cycle”) your hand-held transmitter every 2 seconds until

the indicator light flashes rapidly (indicating successful programming).

#### **NOTE:**

**If programming a garage door opener, etc., it is advised to unplug the device during the “cycling” process to prevent possible damage to the garage door opener components.**

### **OPERATING THE HomeLink<sup>®</sup> UNIVERSAL TRANSCEIVER**

The HomeLink<sup>®</sup> Universal Transceiver (once programmed) may now be used to activate the garage door, etc. To operate, simply press the appropriate programmed HomeLink<sup>®</sup> Universal Transceiver button. The red indicator light will illuminate while the signal is being transmitted.

### **PROGRAMMING TROUBLE DIAGNOSIS**

If the HomeLink<sup>®</sup> does not quickly learn the hand-held transmitter information:

- replace the hand-held transmitter batteries with new batteries.
- position the hand-held transmitter with its battery area facing away from the HomeLink<sup>®</sup> surface.

- press and hold both the HomeLink<sup>®</sup> and hand-held transmitter buttons without interruption.
- position the hand-held transmitter 2 to 5 inches (50 to 127 mm) away from the HomeLink<sup>®</sup> surface. Hold the transmitter in that position for up to 15 seconds. If HomeLink<sup>®</sup> is not programmed within that time, try holding the transmitter in another position - keeping the indicator light in view at all times.

If you continue to have programming difficulties, please contact the INFINITI Consumer Affairs Department. The phone numbers are located in the Foreword of this Owner's Manual.

### **CLEARING THE PROGRAMMED INFORMATION**

Individual buttons cannot be cleared, however to clear all programming, press and hold the two outside buttons and release when the indicator light begins to flash (approximately 20 seconds).

## REPROGRAMMING A SINGLE HomeLink® BUTTON

To reprogram a HomeLink® Universal Transceiver button, complete the following.

1. Press and hold the desired HomeLink® button. **Do not** release the button until step 4 has been completed.
2. When the indicator light begins to flash slowly (after 20 seconds), position the hand-held transmitter 2 to 5 inches (50 to 127 mm) away from the HomeLink® surface.
3. Press and hold the hand-held transmitter button.
4. The HomeLink® indicator light will flash, first slowly and then rapidly. When the indicator light begins to flash rapidly, release both buttons.

The HomeLink® Universal Transceiver button has now been reprogrammed. The new device can be activated by pushing the HomeLink® button that was just programmed. This procedure will not affect any other programmed HomeLink® buttons.

## IF YOUR VEHICLE IS STOLEN

If your vehicle is stolen, you should change the codes of any non-rolling code device that has been programmed into HomeLink®. Consult the Owner's Manual of each device or call the manufacturer or dealer of those devices for additional information.

**When your vehicle is recovered, you will need to reprogram the HomeLink® Universal Transceiver with your new transmitter information.**

### **FCC Notice:**

**This device complies with FCC rules part 15. Operation is subject to the following two conditions: (1) This device may not cause harmful interference and (2) This device must accept any interference that may be received, including interference that may cause undesired operation.**

**The transmitter has been tested and complies with FCC and DOC/MDC rules. Changes or modifications not expressly approved by the party responsible for compliance could void the user's authority to operate the device.**

**DOC: ISTC 1763K1313**

**FCC I.D.: CB2V67690**



# 3 Pre-driving checks and adjustments

Keys .....	3-2	Fuel filler lid .....	3-12
Infiniti vehicle immobilizer system (IVIS) keys .....	3-2	Opening the fuel filler lid .....	3-12
Doors .....	3-3	Fuel filler cap .....	3-13
Locking with key .....	3-3	Steering wheel .....	3-15
Windows open/close with key .....	3-3	Tilt operation .....	3-15
Locking with inside lock knob .....	3-4	Sun visors .....	3-15
Locking with power door lock switch .....	3-4	Mirrors .....	3-16
Child safety rear door lock (Sedan) .....	3-5	Automatic anti-glare inside mirror (if so equipped) .....	3-16
Remote keyless entry system .....	3-5	Outside mirrors .....	3-16
How to use the remote keyless entry system .....	3-5	Automatic drive positioner (if so equipped) .....	3-17
Battery replacement .....	3-8	Automatic drive positioner operation .....	3-17
Hood .....	3-9	Entry/exit function .....	3-17
Trunk lid .....	3-10	Memory storage .....	3-18
Opener operation .....	3-10	System operation .....	3-19
Interior trunk lid release .....	3-11	Cancel switch .....	3-19
Secondary trunk lid release .....	3-11		

## KEYS

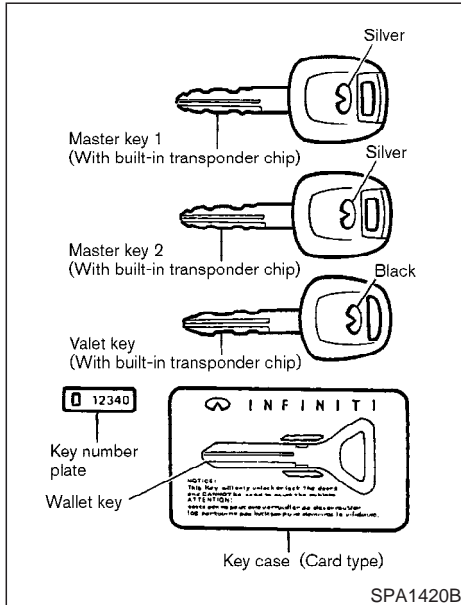

A key number plate is supplied with your keys. Record the key number and keep it in a safe place (such as your wallet), not in the vehicle. If you lose your keys, see an INFINITI dealer for duplicates by using the key number.

### 3-2 Pre-driving checks and adjustments

A key number is necessary when you have lost all keys and do not have one to duplicate from. If you still have a key, your INFINITI dealer can duplicate it.

### INFINITI VEHICLE IMMOBILIZER SYSTEM (IVIS) KEYS

You can only drive your vehicle using the master or valet keys which are registered to the Infiniti Vehicle Immobilizer System components in your vehicle. These keys have a transponder chip in the key head.

The master key can be used for all the locks.

The valet key cannot be used for glove box lock.

To protect belongings when you leave a key with someone, give them the valet key only.

#### Never leave these keys in the vehicle.

Infiniti Vehicle Immobilizer System KEY — Master and Valet keys:

If you still have a key, the key number is not necessary when you need extra Infiniti Vehicle Immobilizer System keys. Your INFINITI dealer can duplicate it. As many as 5 IVIS keys can be used with one vehicle. You should bring all IVIS keys that you have to your INFINITI dealer for registration. This is because the registration process will erase the

memory of all key codes previously registered into the Infiniti Vehicle Immobilizer System. After the registration process, these components will only recognize keys coded into the Infiniti Vehicle Immobilizer System (IVIS) during registration. Any key that is not given to your dealer at the time of registration will no longer be able to start your vehicle.

**Do not allow the immobilizer system key, which contains an electrical transponder, to come into contact with salt water. This could affect system function.**

## DOORS



### WARNING

- Always have the doors locked while driving. Along with the use of seat belts, this provides greater safety in the event of an accident by helping to prevent persons from being thrown from the vehicle. This also helps keep children and others from unintentionally opening the doors, and will help keep out intruders.
- Before opening any door, always look for and avoid oncoming traffic.
- Do not leave children unattended inside the vehicle. They could unknowingly activate switches or controls. Unattended children could become involved in serious accidents.

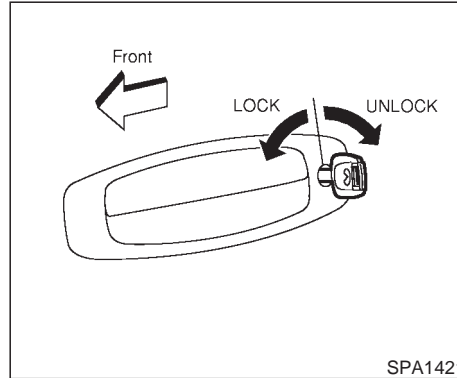

### LOCKING WITH KEY

#### Power

The power door lock system allows you to lock or unlock all doors, trunk lid and fuel filler lid.

- Turning the door key cylinder to the front of the vehicle will lock all doors, trunk lid and fuel filler lid.
- Turning the door key cylinder to the rear of the vehicle once will unlock the driver's door.  
Turning the door key cylinder to the rear of the vehicle again within 5 seconds will unlock all doors and the fuel filler lid.

### WINDOWS OPEN/CLOSE WITH KEY

To open all door windows, turn the door key cylinder to the rear of the vehicle and hold the key for about 1 second.

To stop opening, return the door key cylinder to the neutral position by turning the key.

To close all door windows, turn the door key cylinder to the front of the vehicle and hold the key for about 1 second.

To stop closing, return the door key cylinder to the neutral position by turning the key.

The rear door windows, (if equipped), will operate 0.5 seconds after the front windows' operation.

The door windows will open or close while turning the driver's door key. This function will operate after the ignition switch is off and 45 seconds have passed or until either of the front doors is opened.

In the event of an obstruction, such as a hand, in the way of door windows, the auto reverse function will activate.

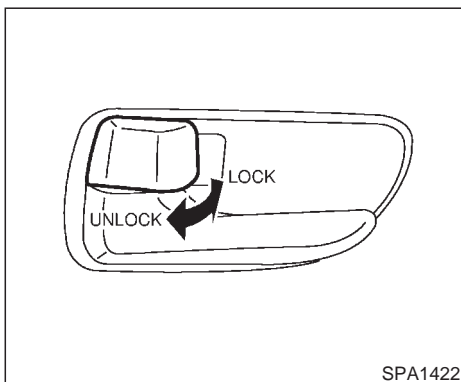

### LOCKING WITH INSIDE LOCK KNOB

To individually lock the doors, push the inside lock knob down to the LOCK position, then close the door.

**When locking the door using inside lock knob, be sure not to leave the key inside of the vehicle.**

To unlock, pull the inside lock knob up to the UNLOCK position.

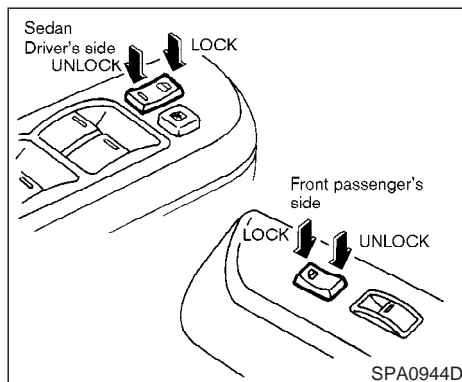

### LOCKING WITH POWER DOOR LOCK SWITCH

All doors will be locked when the power door lock switch is moved to the LOCK position with the driver's or front passenger's door open. Then close the door, and all doors will be locked.

#### Lockout protection

When the power door lock switch (driver or front passenger) is moved to the lock position with the key in the ignition and any door open, all doors will lock and unlock automatically. This helps to prevent the keys from being

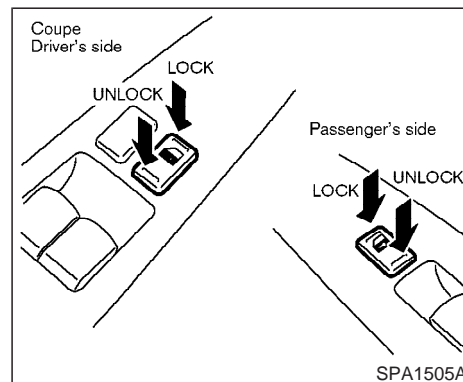

accidentally locked inside the vehicle.

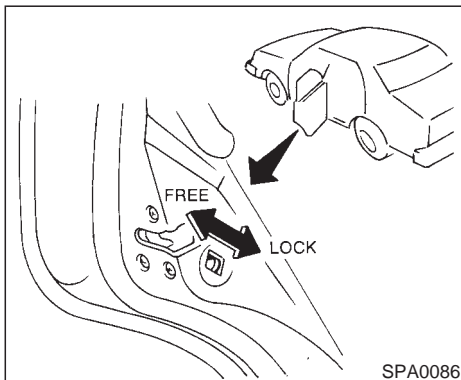

## CHILD SAFETY REAR DOOR LOCK (Sedan)

Child safety rear door lock helps prevent rear doors from being opened accidentally, especially when small children are in the vehicle.

**When the levers are in the LOCK position, the rear doors can be opened by the outside door handles only.**

## REMOTE KEYLESS ENTRY SYSTEM

It is possible to lock/unlock all doors, trunk lid and fuel filler lid and activate the panic alarm by using the keyfob from outside the vehicle. **Before locking the doors, make sure the key is not left in the vehicle.**

The keyfob can operate at a maximum distance of approximately 33 ft (10 m) away from the vehicle. (The operating distance depends upon the conditions around the vehicle.)

As many as 5 keyfobs can be used with one vehicle. For information about purchase and use of additional keyfobs, contact your INFINITI dealer.

The keyfob will not function when:

- the battery is completely discharged,
- the distance between the vehicle and the keyfob is more than 33 ft (10 m).

**The panic alarm will not activate when the key is in the ignition switch.**



### CAUTION

**The following conditions or occurrences may damage the keyfob.**

- **Do not allow the keyfob to become wet.**

- **Do not drop the keyfob.**
- **Do not strike the keyfob sharply against another object.**
- **Do not place the keyfob for an extended period in an area where temperatures exceed 140°F (60°C).**

**If a keyfob is lost or stolen, INFINITI recommends erasing the ID code of that keyfob. This will prevent the keyfob from unauthorized use to unlock the vehicle. For information regarding the erasing procedure, contact an authorized INFINITI dealer.**

## HOW TO USE THE REMOTE KEYLESS ENTRY SYSTEM

Setting hazard indicator and horn mode

The factory setting of the remote keyless entry system is in hazard indicator and horn mode.

In hazard indicator and horn mode, when the LOCK button is pushed, the hazard indicator flashes twice and the horn chirps once. When

the UNLOCK button is pushed, the hazard indicator flashes once.

If horn chirps are not necessary, the system can be switched to hazard indicator mode.

In hazard indicator mode, when the LOCK button is pushed, the hazard indicator flashes twice. When the UNLOCK button is pushed, neither the hazard indicator nor the horn operates.

(Switching procedure)

Push the LOCK and UNLOCK buttons on the keyfob simultaneously for more than 2 seconds to switch from one mode to the other.

When pushing the buttons to set hazard indicator only mode, the hazard indicator flashes 3 times.

When pushing the buttons to set hazard indicator and horn mode, the hazard indicator flashes once and the horn chirps once.

OPERATION GUIDE			
MODE (Push "LOCK" and "UNLOCK" buttons for more than 2 seconds to switch)	Switching indicator	LOCK	UNLOCK
Hazard indicator and horn mode → HAZARD INDICATOR MODE	HAZARD – 3 times	HAZARD – twice	No operation
Hazard indicator mode → HAZARD INDICATOR AND HORN MODE	HAZARD – once HORN – once	HAZARD – twice HORN – once	HAZARD – once

SPA1260A

### Locking doors

1. Remove the ignition key.\*1,\*2
2. Close all doors.\*3
3. Push the LOCK button on the keyfob.
4. All doors, trunk lid and fuel filler lid will lock.

**All doors will lock when the LOCK button on the keyfob is pushed even though a door remains open and/or the ignition key is in any position.**

5. The hazard indicator flashes twice and the horn chirps once.

- When the LOCK button is pushed with all doors locked, the hazard indicator flashes twice and the horn chirps once as a reminder that the doors are already locked.

\*1: Doors lock with the keyfob while a key is in the ignition switch. However, the panic alarm will not activate when the key is in the ignition switch.

\*2: Doors lock with the keyfob while the ignition switch is in the ON position. However, the switching indicators will not function.

\*3: Doors lock with the keyfob while any door is open. However, the switching indicators will not function.

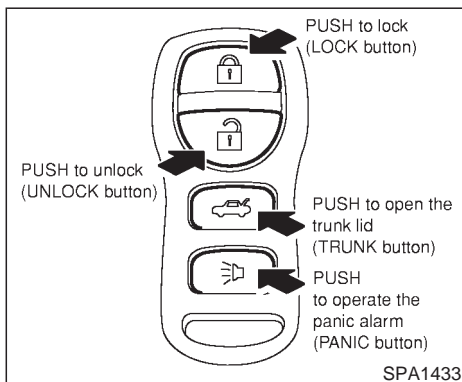

## Unlocking doors

1. Push the UNLOCK button on the keyfob once.
  - The driver's door and fuel filler lid unlock
  - The hazard indicator flashes once if all doors are completely closed with the ignition key in any position except in the ON position.
  - The interior light timer activates and the interior light comes on for 30 seconds when the interior light switch is at the DOOR position with the ignition key in any position except in the ON position.

2. Push the UNLOCK button on the keyfob again within 5 seconds.

- All doors unlock
- The hazard indicator flashes once if all doors are completely closed.

All doors will be locked automatically unless one of the following operations is performed within 1 minute of pressing the UNLOCK button.

- opening any door.
- opening trunk lid.
- turning the ignition switch to the ON position

The interior light can be turned off without waiting for 30 seconds by turning the ignition switch to the ON position or by locking the doors with the keyfob.

## Opening the windows

Push the UNLOCK button on the keyfob.

The driver's door and fuel filler lid will unlock.

Continue to press the UNLOCK button for more than 3 seconds. All the door windows will start to lower.

Continue to press the UNLOCK button until windows are fully open.

To stop the windows lowering operation, release the UNLOCK button.

To start the windows lowering operation, press the UNLOCK button again for more than 3 seconds.

The rear door windows will operate 0.5 seconds after the front windows' operation (if so equipped).

## Releasing the trunk lid

1. Push the TRUNK button on the keyfob for longer than 0.5 seconds when the ignition key is in any position except the ON position.
2. The trunk lid opens.

The trunk lid cannot be opened by operating the keyfob when the ignition key is in the ON position.

## Using the panic alarm

If you are near your vehicle and feel threatened, you may activate the alarm to call attention as follows:

1. Push the PANIC button on the keyfob for **longer than 0.5 seconds** with the key removed from the ignition key cylinder.
2. The theft warning alarm and headlights will

stay on for 30 seconds.

3. The panic alarm stops when:

- It has run for 30 seconds, or
- The LOCK or the UNLOCK button on keyfob is pressed, or
- The PANIC or the TRUNK button is pushed on keyfob for longer than 0.5 seconds.

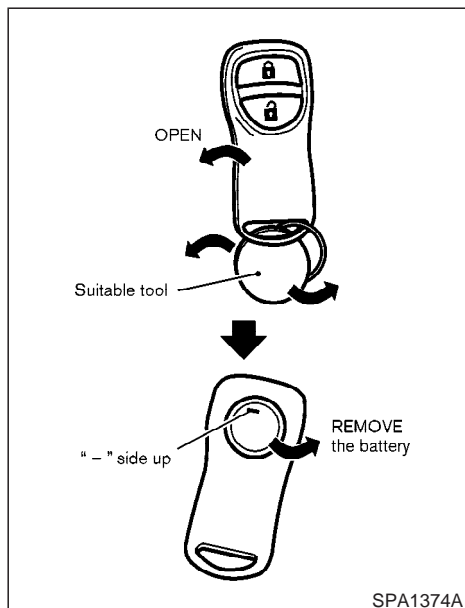

## BATTERY REPLACEMENT

Replace the battery as follows:

1. Open the lid using a suitable tool.
2. Replace the battery with new one.

Recommended battery: CR2025 or equivalent

**Make sure that the ⊕ side faces the bottom case.**

3. Close the lid securely.
4. Push the keyfob button two or three times to check its operation.

See your INFINITI dealer if you need any assistance for replacement.

**If the battery is removed for any reason other than replacement, perform step 4 to check its operation.**

- **Be careful not to touch the circuit board and the battery terminal.**
- **An improperly disposed battery can harm the environment. Always confirm local regulations for battery disposal.**
- **The keyfob is water-resistant; however, if it gets wet, immediately wipe it completely dry.**
- **When changing batteries, do not let dust or oil get on the keyfob.**

**FCC Notice:**

**Changes or modifications not expressly approved by the manufacturer compliance**



## HOOD

could void the user's authority to operate the equipment. This device complies with Part 15 of the FCC Rules and RSS-210 of Industry Canada. Operation is subject to the following two conditions: (1) This device may not cause harmful interference, and (2) this device must accept any interference received, including interference that may cause undesired operation of the device.

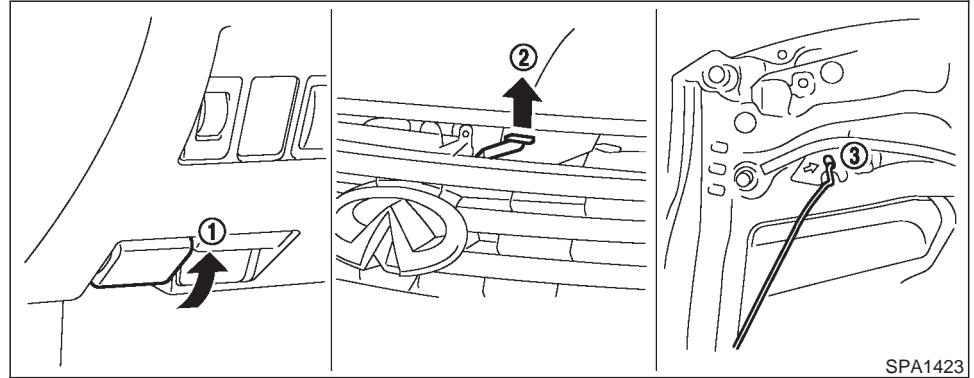

SPA1423

1. Pull the hood lock release handle ① located below the instrument panel; the hood will then spring up slightly.
2. Raise the lever ② at the front of the hood with your fingertips and raise the hood.
3. Insert the assist bar into the slot ③ in the front edge of the hood.
4. When closing the hood, reset the assist bar to its original position, then slowly close the hood and make sure it locks into place.



### WARNING

- **Make sure the hood is completely closed and latched before driving. Failure to do so could cause the hood to fly open and result in an accident.**
- **If you see steam or smoke coming from the engine compartment, to avoid injury do not open the hood.**

## TRUNK LID



### WARNING

- Do not drive with the trunk lid open. This could allow dangerous exhaust gases to be drawn into the vehicle. See “Precautions when starting and driving” in the “5. Starting and driving” section for exhaust gas.
- Closely supervise children when they are around cars to prevent them from playing and becoming locked in the trunk where they could be seriously injured. Keep the car locked with the trunk closed when not in use, and prevent children’s access to car keys.

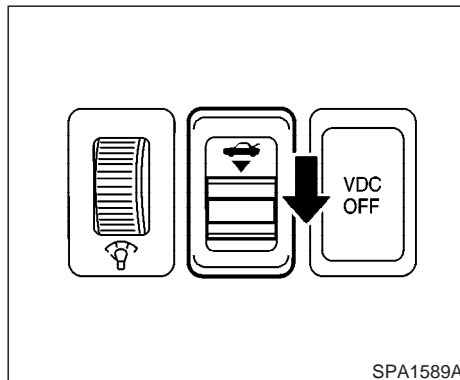

SPA1589A

### OPENER OPERATION

The trunk lid release switch is located at the bottom of the instrument panel.

To open, slide the trunk lid release switch located at the bottom of the instrument panel or press the TRUNK button of the keyfob.

To close, push the trunk lid down securely.

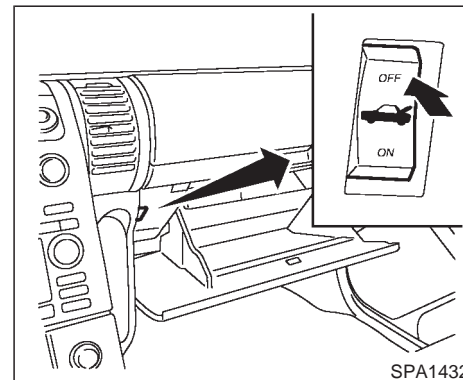

SPA1432

### Cancel switch

When the cancel switch located inside the glove box is OFF, the trunk lid cannot be opened with the trunk lid release switch.

When the cancel switch located inside the glove box is ON, the trunk lid can be opened with the TRUNK button of the keyfob.

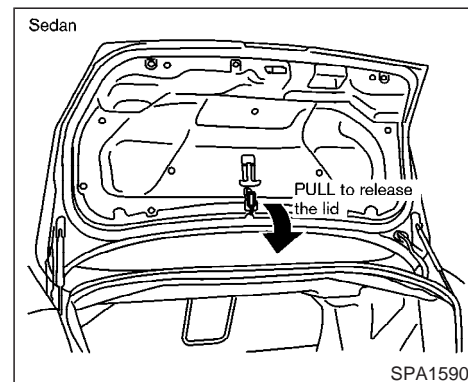
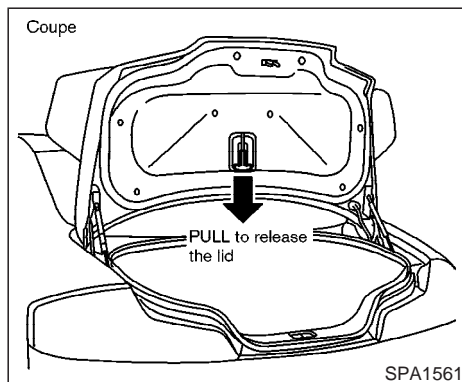
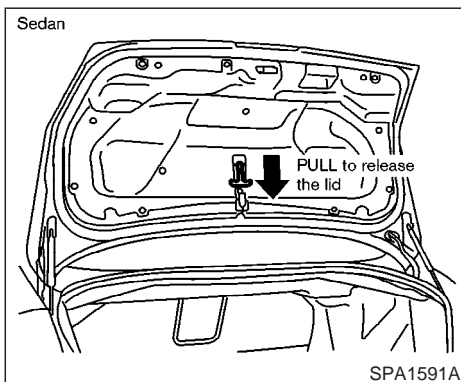

## INTERIOR TRUNK LID RELEASE

The interior trunk lid release mechanism provides a means of escape in the event of becoming locked inside the trunk.

The handle is located on the back side of the trunk lid inside the trunk compartment.

**To open the trunk lid from the inside, pull the release handle towards you until the lock releases and push up on the trunk lid. The release lever is made of a material that glows in the dark after a brief exposure to ambient light.**

## SECONDARY TRUNK LID RELEASE

The secondary trunk lid release mechanism allows opening of the trunk lid in the event of the loss of electrical power such as a discharged battery.

The handle is located on the back side of the trunk lid inside the trunk compartment.

### Sedan

Access the handle through the interior trunk access hole (rear seat armrest).

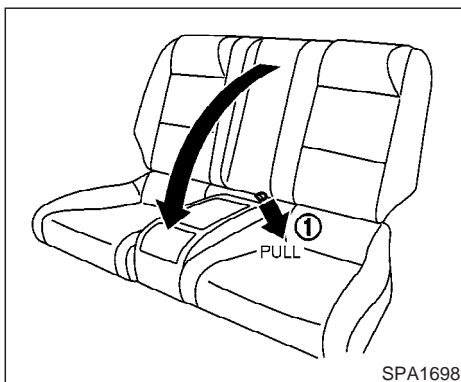

pull the release handle towards front of vehicle until the lock releases.

**To open the trunk lid from the rear seat, pull the release handle towards front of vehicle until the lock releases.**

Return the handle to the original position by securing the latch. Otherwise, it may cause water to leak into the trunk.

## Coupe

Access the handle from the rear seat.

Fold down the rear seatback by pulling the strap, located at center bottom of the seatback sideways ①.

**To open the trunk lid from the rear seat,**

## 3-12 Pre-driving checks and adjustments

## FUEL FILLER LID

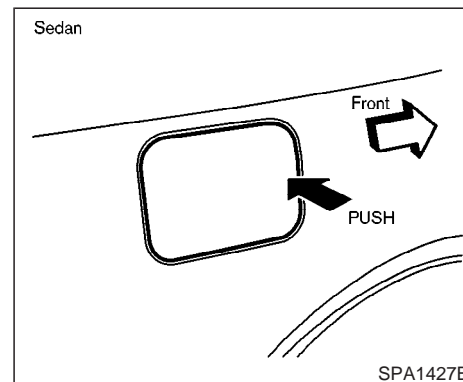

## OPENING THE FUEL FILLER LID

To open the fuel filler lid, unlock the fuel filler lid lock by using one of the following operations, then push the right-hand side of the lid (Sedan), the left-hand side of the lid (Coupe).

- Press the unlock button on the keyfob once.
- Insert the key into the door lock cylinder and turn the door key cylinder to the rear of the vehicle.
- Press the power door lock switch to the unlock position.

To lock, close the fuel filler lid and lock the doors.

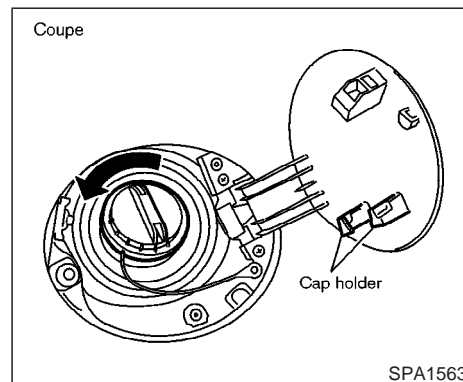
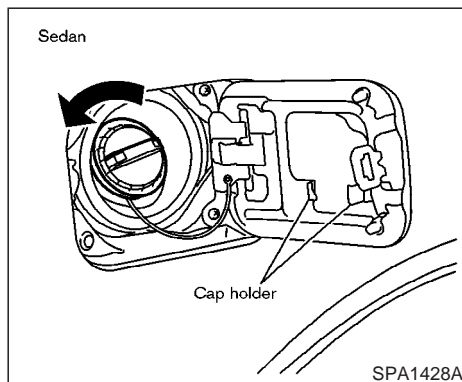
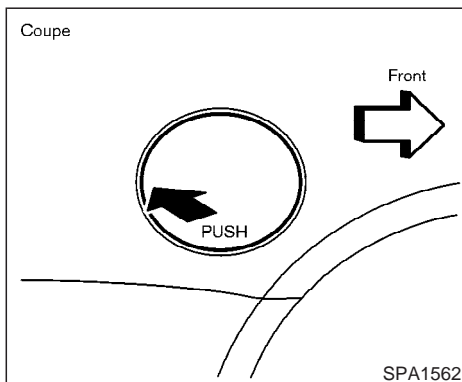

## FUEL FILLER CAP

The fuel filler cap is a ratcheting type. Tighten the cap clockwise until ratcheting clicks are heard.

Put the fuel filler cap on the cap holder while refueling.



### WARNING

- Gasoline is extremely flammable and highly explosive under certain conditions. You could be burned or seri-

ously injured if it is misused or mishandled. Always stop the engine and do not smoke or allow open flames or sparks near the vehicle when refueling.

- Fuel may be under pressure. Turn the cap a third of a turn, and wait for any hissing sound to stop to prevent fuel from spraying out and possible personal injury.
- Do not attempt to top off the fuel tank

after the fuel pump nozzle shuts off automatically. Continued refueling may cause fuel overflow, resulting in fuel spray and possibly a fire.

- Use only an original equipment type fuel filler cap as a replacement. It has a built-in safety valve needed for proper operation of the fuel system and emission control system. An incorrect fuel filler cap can result in a serious malfunction and possible injury. An incorrect fuel filler cap could also cause the SERVICE ENGINE SOON malfunction indicator lamp to illuminate.
- Do not fill a portable fuel container in the vehicle or trailer. Static electricity can cause an explosion of flammable liquid, vapor or gas in any vehicle or trailer. To reduce the risk of serious injury or death when filling portable fuel containers:
  - Always place the container on the ground while filling.
  - Do not use electronic devices while filling.
  - Keep the pump nozzle in contact with the container while filling.

- Use only approved portable fuel containers for flammable liquid.
- Never pour fuel into the throttle body to attempt to start your vehicle.



## CAUTION

- If fuel is spilled on the car body, flush it away with water to avoid paint damage.
- Tighten until the fuel filler cap clicks. Failure to tighten the fuel filler cap properly may cause the SERVICE ENGINE SOON malfunction indicator lamp (MIL) to illuminate. If the SERVICE ENGINE SOON lamp illuminates because the fuel filler cap is loose or missing, tighten or install the cap and continue to drive the vehicle. The SERVICE ENGINE SOON lamp should turn off after a few driving trips. If the SERVICE ENGINE SOON lamp does not turn off after a few driving trips, have the vehicle inspected by an authorized INFINITI dealer.

- For additional information, see the “Malfunction indicator lamp (MIL)” in the “2. Instruments and controls” section.

## STEERING WHEEL

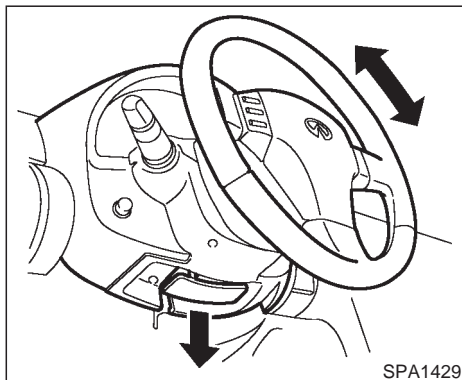

### TILT OPERATION

Pull the lock lever down and adjust the steering wheel up or down to the desired position.

Push the lock lever back into place to secure the steering wheel position.



### WARNING

Do not adjust the steering wheel while driving. You could lose control of your vehicle and cause an accident.

## SUN VISORS

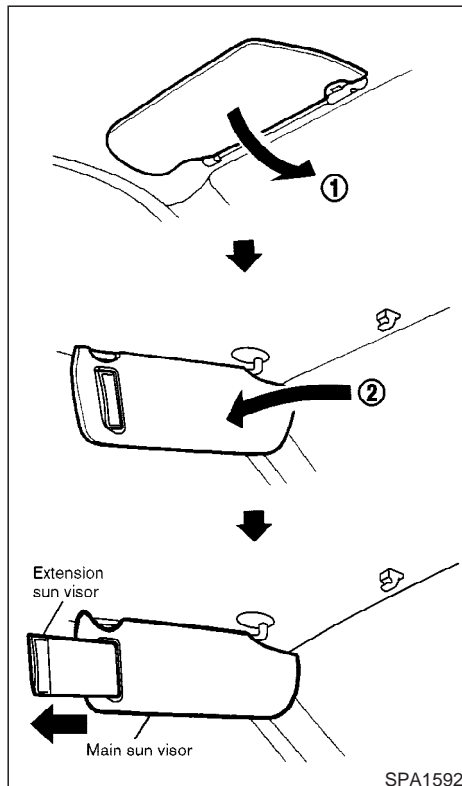

### CAUTION

Store the main sun visor after storing the extension sun visor.

## MIRRORS

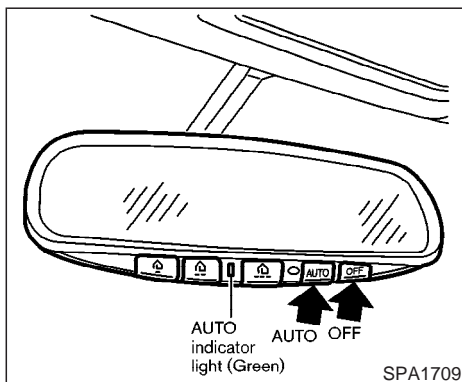

### AUTOMATIC ANTI-GLARE INSIDE MIRROR (if so equipped)

The inside mirror is designed so that it automatically changes reflection according to the intensity of the headlight of the following vehicle.

When the inside mirror is in the AUTO position, excessive glare from the headlights of the vehicle behind you will be reduced. When the switch of the inside mirror is in the OFF position, the inside mirror will operate normally.

For HomeLink® Universal Transceiver, see the **3-16 Pre-driving checks and adjustments**

description in the “2. Instruments and controls” section.

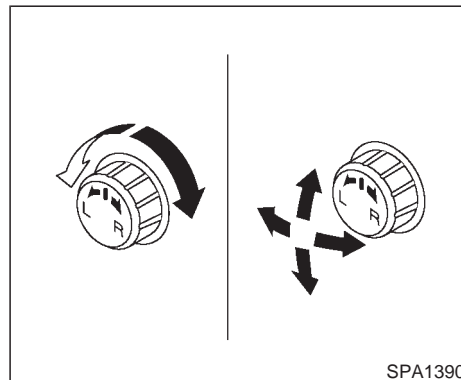

### OUTSIDE MIRRORS



### WARNING

**Objects viewed in the outside mirror on the passenger side are closer than they appear. Be careful when moving to the right. Using only this mirror could cause an accident. Use inside mirror or glance over your shoulder to properly judge distances to other objects.**

The outside mirror adjustment will operate only



when the ignition switch is in the ACC or ON position.

Turn the control knob right or left to select the right or left outside mirror, then adjust by tilting the control knob.

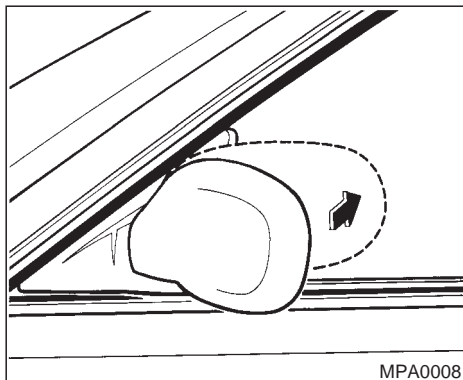

### Foldable outside mirrors

Fold the outside mirror by pushing it toward the rear of the vehicle.

## **AUTOMATIC DRIVE POSITIONER (if so equipped)**

### **AUTOMATIC DRIVE POSITIONER OPERATION**

The automatic drive positioner system has two features:

- Entry/exit function (only available on models equipped with automatic transmission)
- Memory storage

### **ENTRY/EXIT FUNCTION**

This system is designed so that the driver's seat and steering column will automatically move when the automatic transmission selector lever is in the P (Park) position. This allows the driver to get into and out of the driver's seat more easily. (This feature is not available on models equipped with manual transmission.)

The driver's seat will slide backward:

- When the key is removed from the ignition switch.
- When the driver's door is opened with the key turned to LOCK.
- When the key is turned from ACC to LOCK with the driver's door open while the automatic transmission selector lever is in the P (Park) position.

The driver's seat will return to the previous position:

- When the key is inserted into the ignition switch.
- When the driver's door is closed with the key turned to LOCK.
- When the key is turned from ACC to ON while the automatic transmission selector lever is in the P (Park) position.

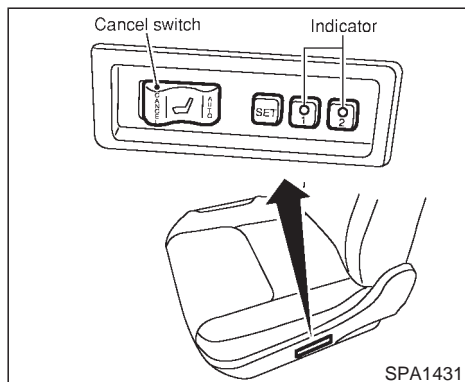

## MEMORY STORAGE

Two positions for the driver's seat can be stored in the automatic drive positioner memory. Follow these procedures to use the memory system.

1. For vehicles equipped with automatic transmission, set the shift selector lever to the P (Park) position.

For vehicles equipped with manual transmission, place the shift lever in the N (Neutral) position and set the parking brake.

2. Turn the ignition ON.

3. Adjust the driver's seat, steering column and outside mirrors to the desired positions by manually operating each adjusting switch. For additional information, see "Seats" in the "Safety — Seats, seat belts and supplemental air bags" section and "Steering wheel" and "Outside mirrors" earlier in this section.

During this step, do not turn the ignition to any positions other than ON.

4. Push the SET switch and, within 5 seconds, push the memory switch (1 or 2) fully for at least 1 second.

The indicator light for the pushed memory switch will come on and stay on for approximately 5 seconds after pushing the switch. After the indicator light goes off, the selected positions are stored in the selected memory (1 or 2).

If memory is stored in the same memory switch, the previous memory will be deleted.

## Confirming memory storage

- Turn the ignition ON and push the SET switch. If the main memory has not been stored, the indicator light will come on for approximately 0.5 seconds. When the memory has stored in position, the indicator

light will stay on for approximately 5 seconds.

- If the battery cable is disconnected, or if the fuse opens, the memory will be canceled. In such a case, reset the desired positions using the following procedures.
1. Open and close the driver's door more than two times with the ignition key in the LOCK position.
  2. Reset the desired position using the previous procedure.

### Selecting the memorized position

1. For vehicles equipped with automatic transmission, set the shift selector lever to the P (Park) position.

For vehicles equipped with manual transmission, place the shift lever in the N (Neutral) position and set the parking brake.

2. Turn the ignition ON.
3. Push the memory switch (1 or 2) fully for at least 1 second.

The driver's seat will move to the memorized position with the indicator light flashing, and then the light will stay on for approximately 5 seconds.

## SYSTEM OPERATION

The automatic drive positioner system will not work or will stop operating under the following conditions:

- when the vehicle speed is above 4 MPH (7 km/h).
- when any two or more of the memory switches are simultaneously pressed while the automatic drive positioner is operating.
- when the adjusting switch for the driver's seat is turned on while the automatic drive positioner is operating.
- when the cancel switch is pushed to cancel.
- when the memory switch 1 or 2 is not pushed for at least 1 second.
- when the seat has already been moved to the memorized position.
- when no seat position is stored in the memory switch.
- when the parking brake is not applied. — M/T models
- when the vehicle speed is above 4 MPH (7 km/h) while the parking brake is applied. — M/T models  
To restart the drive positioner system, move the parking brake to off and on.

- when the engine is started while moving the automatic drive positioner. — M/T models

## CANCEL SWITCH

When the CANCEL side of the switch is pushed, the automatic drive positioner system will not function.

When the AUTO side of the switch is pushed, the system will function.

# MEMO

# 4 Heater, air conditioner and audio systems

Ventilators .....	4-2	AM radio reception .....	4-7
Heater and air conditioner (Automatic) .....	4-3	Satellite radio reception.....	4-8
Automatic operation .....	4-4	Audio operation precautions .....	4-8
Manual operation.....	4-4	FM-AM-satellite radio with cassette player and	
Dual zone button (if so equipped).....	4-5	compact disc (CD) changer.....	4-11
Ambient temperature.....	4-5	CD care and cleaning .....	4-16
Operating tips .....	4-5	Steering switch for audio control (if so	
In-cabin microfilter .....	4-5	equipped).....	4-17
Servicing air conditioner.....	4-6	Antenna .....	4-17
Audio system.....	4-6	Car phone or CB radio .....	4-18
FM radio reception .....	4-7		

## VENTILATORS

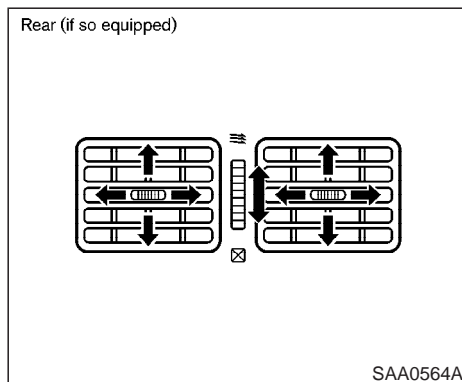
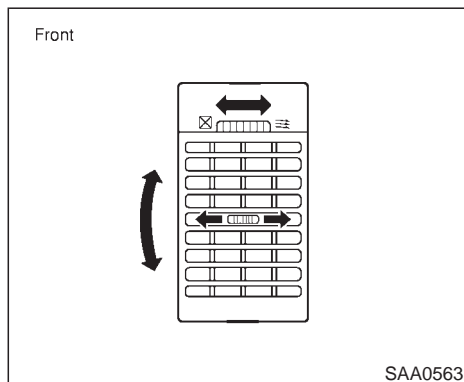

Adjust the air flow direction of ventilators.

Open or close, and adjust the air flow direction of ventilators.

- ☒ : This symbol indicates that the vents are closed when the vent lever is moved left (front) or down (rear).
- ≡ : This symbol indicates that the vents are open when the vent lever is moved right (front) or up (rear).

## HEATER AND AIR CONDITIONER (Automatic)

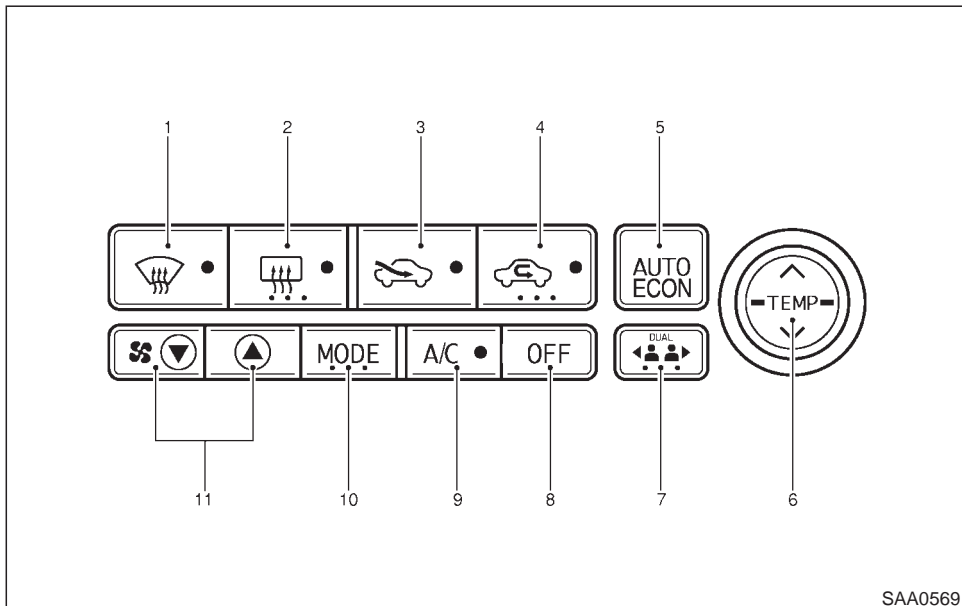

1. DEF button
2. Rear window defroster button (Refer to the "2. Instruments and controls" section.)
3. Fresh air button
4. Air recirculation button
5. AUTO/ECON button
6. Temperature set button
7. DUAL zone button (if so equipped)
8. OFF button
9. A/C button
10. Manual air flow control button
11. Manual fan control button



### WARNING

- The air conditioner cooling function operates only when the engine is running.
- Do not leave children, impaired adults, or pets alone in your vehicle.

On hot, sunny days, temperatures in a closed vehicle could quickly become high enough to cause severe or possibly fatal injuries to people or animals.

- Do not use the recirculation mode for long periods as it may cause the interior air to become stale and the windows to fog up.
- Positioning of the heating or air conditioning controls should not be done while driving, so full attention may be given to vehicle operation.

Start the engine and operate the controls to activate the air conditioner.

## AUTOMATIC OPERATION

### Cooling and/or dehumidified heating (AUTO)

This mode may be normally used all year round as the system automatically works to keep a constant temperature. Air flow distribution and fan speed are also controlled automatically.

1. Push the AUTO/ECON button on. (AUTO will be displayed.)
2. If the A/C button indicator is off, push the A/C button to activate air conditioner. The A/C button indicator will come on.
3. Push the temperature set button to set the desired temperature.
  - Adjust the temperature to about 75°F (24°C) for normal operation.
  - The temperature of the passenger compartment will be maintained automatically. Air flow distribution and fan speed are also controlled automatically.

### Economical operation (ECON)

Economical operation reduces some load to the engine to improve the fuel economy. It allows higher humidity than normal operation.

## 4-4 Heater, air conditioner and audio systems

Pushing the AUTO/ECON button changes operations as follows while the A/C button indicator is on. AUTO → ECON → AUTO

### Heating (A/C off)



The air conditioner does not activate. When you need to heat only, use this mode.

1. Push the AUTO button. (AUTO will be displayed.)
2. Push the A/C button to turn off the air conditioner. The A/C button indicator will turn off.
3. Push the temperature set button to set the desired temperature.
  - The temperature of the passenger compartment will be maintained automatically. Air flow distribution and fan speed are also controlled automatically.
  - Do not set the temperature lower than the outside air temperature. Otherwise the system may not work properly.
  - Not recommended if windows fog up.

### Dehumidified defrosting or defogging

1. Push the DEF button  on. (The indicator light on the button will come on.)



2. Push the temperature set button to set the desired temperature.

- To quickly remove ice from the outside of the windows, push the manual fan control button  and set to the maximum position.
- As soon as possible after the windshield is clean, push the AUTO button to return to the auto mode.
- When the DEF button  is pushed, the air conditioner will automatically be turned on at outside temperatures above 23°F (-5°C) to defog the windshield, and the air recirculate mode will automatically be turned off.

Outside air is drawn into the passenger compartment to improve the defogging performance.

## MANUAL OPERATION

### Fan speed control

Push the fan control button  or  to manually control the fan speed.

Push the AUTO button to return to automatic control of the fan speed.

### Fresh air

Push the fresh air button  to draw outside



air into the passenger compartment. The indicator light on the button will come on.





### Air recirculation

Push the air recirculation button  to recirculate interior air inside the vehicle. The indicator light on the button will come on.

The air recirculation button will not be activated when the air conditioner is in DEF mode.

### Air flow control (MODE)

Pushing the MODE button selects the air outlet to:

-  : Air flows from center and side ventilators.
-  : Air flows from center and side ventilators and foot outlets.
-  : Air flows mainly from foot outlets.
-  : Air flows from defroster and foot outlets.

### To turn the system off

Push the OFF button.

### DUAL ZONE BUTTON (if so equipped)

You can set the temperature of the driver and

front passenger sides individually.

Pushing the DUAL zone button changes the setting position as follows:

Driver/Passenger → Driver → Passenger

If selecting the Driver/Passenger position again after the temperature is individually set, the display will show the temperature set for the driver side.

### AMBIENT TEMPERATURE

The outside ambient temperature will be shown on the center display.

The ambient temperature sensor is located in front of the radiator. The sensor may be affected by road or engine heat, wind direction and other driving conditions. The display may differ from the actual outside temperature or the temperature displayed on various signs or billboards.

### OPERATING TIPS

When the engine coolant temperature and outside air temperature are low, the air flow from the foot outlets may not operate for a maximum of 150 seconds. However, this is not a malfunction. After the coolant temperature warms up, the air flow from the foot outlets will operate normally.

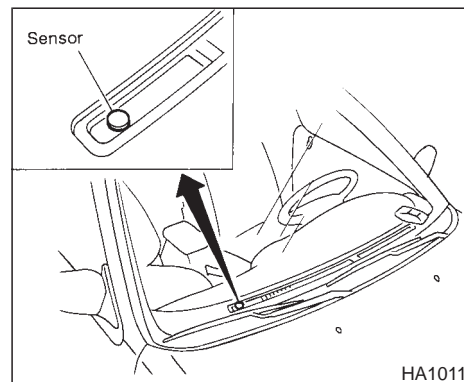

HA1011

The sensor on the instrument panel helps maintain a constant temperature; do not put anything on or around this sensor.

### IN-CABIN MICROFILTER

The air conditioning system is equipped with an in-cabin microfilter which collects dirt, pollen, dust, etc. To make sure air conditioner heats, defogs, and ventilates efficiently, replace the filter in accordance with the maintenance schedule in the INFINITI Service and maintenance guide. To replace the filter, contact your INFINITI dealer.

**The filter should be replaced if air flow Heater, air conditioner and audio systems 4-5**

**decreases significantly or if windows fog up easily when operating the heater or air conditioning system.**

## SERVICING AIR CONDITIONER

The air conditioning system in your INFINITI vehicle is charged with a refrigerant designed with the environment in mind. **This refrigerant will not harm the earth's ozone layer.** However, special charging equipment and lubricant are required when servicing your NISSAN air conditioner. Using improper refrigerants or lubricants will cause severe damage to your air conditioning system. See "Capacities and recommended fuel/lubricants" in the "9. Technical and consumer information" section for air conditioning system refrigerant and lubricant recommendations.

Your INFINITI dealer will be able to service your environmentally friendly air conditioning system.



### WARNING

**The air conditioner system contains refrigerant under high pressure. To avoid personal injury, any air conditioner service should be done only by an experienced technician with proper equipment.**

## AUDIO SYSTEM

Turn the ignition key to ACC or ON and press the POWER, FM or AM button to turn on the radio. If you listen to the radio with the engine not running, the key should be turned to the ACC position.

Radio reception is affected by station signal strength, distance from radio transmitter, buildings, bridges, mountains and other external influences. Intermittent changes in reception quality normally are caused by these external influences.

**Using a cellular phone in or near the vehicle may influence radio reception quality.**

### Radio reception

Your radio system is equipped with state-of-the-art electronic circuits to enhance radio reception. These circuits are designed to extend reception range, and to enhance the quality of that reception.

However there are some general characteristics of FM, AM and satellite radio signals that can affect radio reception quality in a moving vehicle, even when the finest equipment is used. These characteristics are completely normal in a given reception area, and do not indicate any malfunction in your radio system.

Remember that a moving vehicle is not the ideal place to listen to a radio. Because of the

movement, reception conditions will constantly change. Buildings, terrain, signal distance and interference from other vehicles can work against ideal reception. Described below are some of the factors that can affect your radio reception.

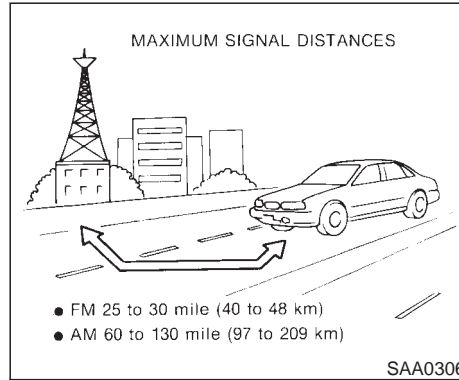

## FM RADIO RECEPTION

**Range:** FM range is normally limited to 25 to 30 miles (40 to 48 km), with monaural (single channel) FM having slightly more range than stereo FM. External influences may sometimes interfere with FM station reception even if the FM station is within 25 miles (40 km). The strength of the FM signal is directly related to the distance between the transmitter and receiver. FM signals follow a line-of-sight path, exhibiting many of the same characteristics as light. For example they will reflect off objects.

**Fade and drift:** As your vehicle moves away

from a station transmitter, the signals will tend to fade and/or drift.

**Static and flutter:** During signal interference from buildings, large hills or due to antenna position, usually in conjunction with increased distance from the station transmitter, static or flutter can be heard. This can be reduced by adjusting the treble control counterclockwise to reduce treble response.

**Multipath reception:** Because of the reflective characteristics of FM signals, direct and reflected signals reach the receiver at the same time. The signals may cancel each other, resulting in momentary flutter or loss of sound.

## AM RADIO RECEPTION

AM signals, because of their low frequency, can bend around objects and skip along the ground. In addition, the signals can be bounced off the ionosphere and bent back to earth. Because of these characteristics, AM signals are also subject to interference as they travel from transmitter to receiver.

**Fading:** Occurs while the vehicle is passing through freeway underpasses or in areas with many tall buildings. It can also occur for several seconds during ionospheric turbulence even in areas where no obstacles exist.

**Static:** Caused by thunderstorms, electrical

power lines, electric signs and even traffic lights.

## SATELLITE RADIO RECEPTION

When the satellite radio is first installed or the battery has been replaced, the satellite radio may not work properly. This is not a malfunction. Wait more than 10 minutes with satellite radio ON for satellite radio to receive all of the necessary data.

## AUDIO OPERATION PRECAUTIONS

### Cassette player

- To maintain good quality sound, **INFINITI** recommends using cassette tapes of 60 minutes or shorter in length.
- Cassette tapes should be removed from the player when not in use. Store cassettes in their protective cases and away from direct sunlight, heat, dust, moisture and magnetic sources.
- Direct sunlight can cause the cassette to become deformed. The use of deformed cassettes may cause the cassette to jam in the player.
- Do not use cassettes with labels which are peeling and loose. If used, the label

4-8 Heater, air conditioner and audio systems

could jam in the player.

- If a cassette has loose tape, insert a pencil through one of the cassette hubs and rewind the tape firmly around the hubs. Loose tape may cause tape jamming and wavering sound quality.
- Over a period of time, the playback head, capstan and pinch roller may collect a tape coating residue as the tape is played. This residue accumulation can cause weak or wavering sound, and should be removed periodically with a head cleaning tape. If the residue is not removed periodically, the player may need to be disassembled for cleaning.

### Compact Disc (CD) player

- During cold weather or rainy days, the player may malfunction due to the humidity. If this occurs, remove the CD and dehumidify or ventilate the player completely.
- The player may skip while driving on rough roads.
- The CD player sometimes cannot function when the compartment temperature is extremely high. Decrease the temperature before use.

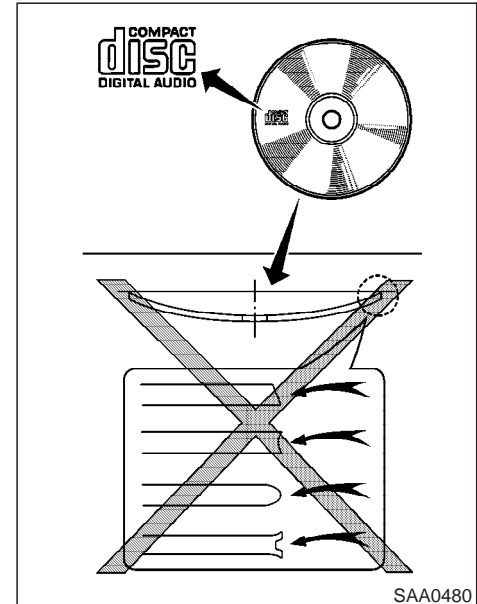

- Only use high quality 4.7 inches (12 cm) round discs that have the "COMPACT disc DIGITAL AUDIO" logo on the disc or packaging.
- Do not expose the CD to direct sunlight.

- CDs that are of poor quality, dirty, scratched, covered with fingerprints, or that have pin holes may not work properly.
- The following CDs may not work properly:
  - Copy control compact discs (CCCD)
  - Recordable compact discs (CD-R)
  - Rewritable compact discs (CD-RW)
- Do not use the following CDs as they may cause the CD player to malfunction.
  - 3.1 in (8 cm) discs with an adapter
  - CDs that are not round
  - CDs with a paper label
  - CDs that are warped, scratched, or have abnormal edges

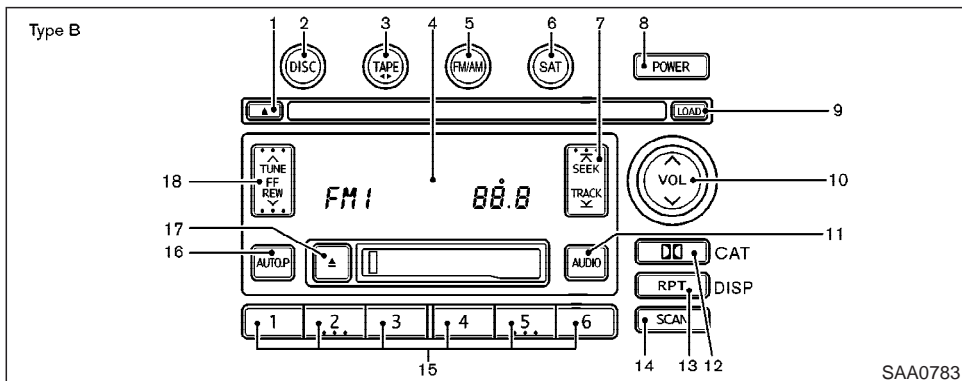
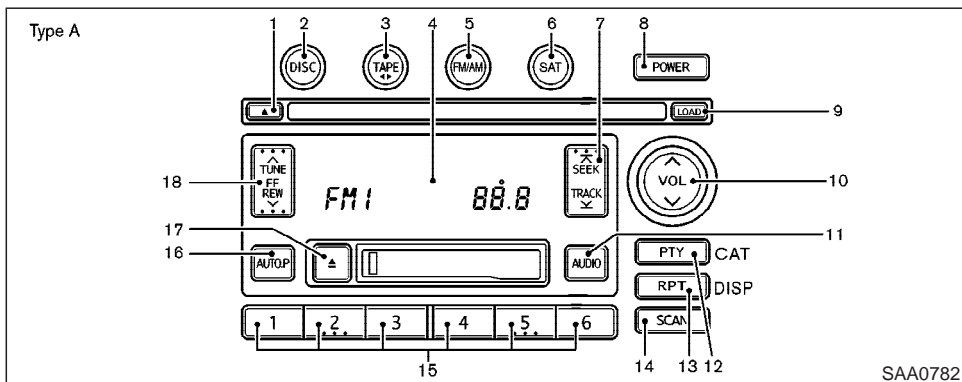

## FM-AM-SATELLITE RADIO WITH CASSETTE PLAYER AND COMPACT DISC (CD) CHANGER

### Audio main operation

#### Head unit:



The radio has an FM diversity reception system, which employs two antennas printed on the rear window. This system automatically switches to the antenna which is receiving less interference.

The tape deck employs a permalloy head which allows for improved reproduction of high frequency ranges. Noise is also greatly reduced by the combined use of the Dolby NR (Noise Reduction) system. The auto loudness circuit enhances the low frequency range automatically in both radio reception and tape and CD playback.

#### POWER on/off:

Turn the ignition key to ACC or ON, and then push the POWER on/off button while the system is off to call up the mode (radio, tape or CD) which was playing immediately before the system was turned off. When no CD or tape is loaded, the radio will come on. While the system is on, pushing the POWER on/off button turns the system off.

#### Volume control:





Push the volume control button (VOL)  (down) or  (up) to adjust the volume.

This vehicle has **Speed sensitive Control Volume (SCV) for audio**. The audio volume changes as the driving speed changes.

#### AUDIO button (BASS, TREBLE, FADER, BALANCE, SCV and (NR (Dolby) — Type A only)):



Press the AUDIO button to change the select mode as follows.

BASS → TREBLE → FADER → BALANCE → SCV → NR (when cassette playing) — type A only → (Normal) → BASS

To adjust Bass, Treble, Fader and Balance, press the AUDIO button until the desired mode BASS, TREBLE, FADER or BALANCE appears in the display. Press the TUNE (  or  ) button to adjust Bass and Treble to the desired level. Use the  or  button also to adjust Fader or Balance modes. Fader adjusts the sound level between the front and rear speakers and Balance adjusts the sound between the right and left speakers.

To change the SCV mode to OFF, LOW, MID

or HIGH, press the  or  (TUNE) button.

To change the NR (Dolby) mode to OFF or ON, press the  or  (TUNE) button while cassette tape is playing. When Dolby is ON, the display indicates the  mark. (type A only)

After 10 seconds, the radio, cassette tape or CD display reappears. Once the sound quality is set to the desired level, press the AUDIO button repeatedly until the radio, cassette tape or CD display appears.

Dolby noise reduction manufactured under license from Dolby Laboratories Licensing Corporation. Dolby NR and the double-D symbol  are trademarks of Dolby Laboratories Licensing Corporation.

#### Metal or chrome tape usage:

The cassette player will be automatically set to high performance play when playing a metal or chrome cassette tape.

### FM-AM radio operation

#### FM/AM band select:

Pushing the FM/AM band select button will change the band as follows:

AM → FM1 → FM2 → AM

When FM/AM band select button is pushed while the ignition switch is in the ACC or ON, the radio will come on at the station last played.

The last station played will also come on when the POWER button is turned to ON.

If another audio source is playing when the FM/AM band select button is turned to ON, the other audio source will automatically be turned off and the last radio station played will come on.

The FM stereo indicator ST will glow during FM stereo reception. When the stereo broadcast signal is weak, the radio will automatically change from stereo to monaural reception.

Satellite radio operation (if so equipped)

**SAT** Satellite channel select:

Pushing the SAT band select button will change the band as follows:

SAT1 → SAT2 → SAT1

No satellite radio reception is available and “NO SAT” is displayed when the SAT button is pressed unless optional satellite receiver and antenna are installed and an XM<sup>®</sup> or

SIRIUS<sup>™</sup> satellite radio service subscription is active.

When SAT band select button is pushed while the ignition switch is in the ACC or ON position, the radio will come on at the channel last played.

The last channel played will also come on when the POWER button is turned to ON.

If another audio source is playing when the SAT band select button is turned to ON, the other audio source will automatically be turned off and the last channel played will come on.



**TUNE (Tuning):**



**WARNING**



**The radio should not be tuned while driving so full attention may be given to vehicle operation.**

Use these buttons for manual tuning. To move quickly through the channels, hold either of the TUNE buttons down for more than 0.5 seconds.





**SEEK tuning:**

For AM and FM radio:

Push the SEEK button  or , to tune from high to low or low to high frequencies and stops at the next broadcasting station.

For satellite radio:

Push the SEEK button  or  to seek channels of the next or previous category.

**SCAN**

**SCAN tuning:**

Push the SCAN tuning button to tune from low to high frequencies and stops at each broadcasting station for 5 seconds. Pushing the button again during this 5 seconds period will stop SCAN tuning and the radio will remain tuned to that station.

If the SCAN tuning button is not pushed within 5 seconds, SCAN tuning moves to the next station.

**RPT**

**(DISP) Display mode of satellite radio:**

- Pushing the RPT button will display additional information about the satellite radio broadcast (for example: Artist name, Title).
- Keep pushing the RPT button, and it will change the information of the satellite radio broadcast to be displayed as follows:



CH Number → CH Name → Artist Name →  
Song Title → CH Number

### Station memory operations:

Twelve stations/channels can be set for the FM band (six for FM1, six for FM2), twelve for satellite radio (six for SAT1, six for SAT2) and six stations can be set for the AM band.

1. Tune to the desired station using the SEEK, SCAN or TUNE button.
2. Select the desired station/channel and keep pushing any of the desired station/channel memory buttons (1 to 6) until a beep sound is heard. (The radio mutes when the select button is pushed.)
3. The channel indicator will then come on and the sound will resume. Memorizing is now complete.
4. Other buttons can be set in the same manner.

If the battery cable is disconnected, or if the fuse blows, the radio memory will be erased. In that case, reset the desired stations.

### **AUTO.P** Automatic preset:

To select the preset FM, AM, SAT or PTY station/channel, push the AUTO.P button for less than 1.5 seconds.



To preset the FM, AM, SAT or PTY station/channel, push the AUTO.P button for more than 1.5 seconds.



### **PTY** (CAT) Program type/category (type A) or (CAT) Dolby/category (type B):

When the PTY button is pressed for more than 1.5 seconds during FM mode, the PTY name of the current tuned station is displayed. (Type A)

When the PTY (CAT) — type A, or  (CAT) — Type B, button is pressed for more than 1.5 seconds during the satellite radio mode, the category name of the current channel is displayed. During this time if the PTY data code is zero, or the data is unreadable; the display will show NONE.

#### 1. PTY (CAT) selection mode

PTY (CAT) name selection can be done by the up/down TUNE button  or  in the PTY (CAT) selection mode.

It is possible to shift the PTY (CAT) name by one step, with one push of the up/down tuning button  or .



PTY name selection can also be achieved by pressing the preset buttons.

Initial PTY names are stored in the preset

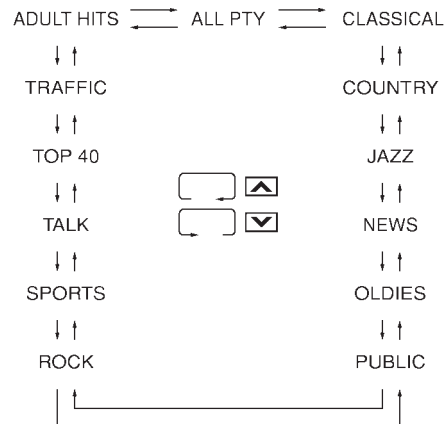
buttons; but these can be changed by pressing the preset buttons for more than 1.5 seconds when the desired PTY name is in the display.



#### 2. PTY SEEK tuning mode

After selecting a PTY name, push the SEEK button  or  within 10 seconds. Tuning to the PTY station will start. If you do not push the SEEK button within the 10 second period, the PTY mode will be canceled.

### 3. PTY SCAN tuning mode

Push the SCAN tuning button to tune the PTY name station, and stop at each broadcasting station for 5 seconds. Pushing the button again during this 5 second period will stop SCAN tuning and the radio will remain tuned to that station. If the SCAN tuning button is not pushed within 5 seconds, SCAN tuning moves to the next station.

### Cassette tape player operation

Turn the ignition key to ACC or ON, and then lightly insert the cassette tape into the tape door. The cassette tape will be automatically pulled into the player.

The radio or CD will turn off (if it is on) and the cassette tape will begin to play.



### CAUTION

**Do not force the cassette tape into the tape door. This could cause player damage.**

If the system is turned off by pushing the ON-OFF/VOL control knob with the cassette tape still in the player, the tape will resume playing when the system is turned back on.

### 4-14 Heater, air conditioner and audio systems







PLAY:

- When the TAPE button is pushed with the system turned off and a tape loaded, the system will come on and the tape will play.
- When the TAPE button is pushed with either the radio or compact disc turned on and a tape loaded, the compact disc or the radio will automatically be turned off and the tape will play.
- When the TAPE button is pushed with the TAPE playing, the tape will play the program recorded on the reverse side.





**FF (Fast Forward), REW (Rewind):**



Push the  (fast forward) button to fast forward the tape. To rewind the tape, push the  (rewind) button. Either the FF or REW symbol illuminates on the right side of the display window. To stop the FF or REW function, press the  (fast forward) or  (rewind) again, or the TAPE button.



**APS (Automatic Program Search) FF, APS REW:**

When the  (APS FF) button is pushed while the tape is being played, the next program will start to play from the beginning. Push

the  (APS FF) button several times to skip through programs. The tape will advance the number of times the button is pushed (up to nine programs).

When the  (APS REW) button is pushed once, the program being played starts over from the beginning. Push the  (APS REW) button several times to skip back several selections. The tape will go back the number of times the button is pushed. Either the FF or REW symbol flashes on the right side of the display window while searching for the selection.

This system searches for the blank intervals between selections. If there is a blank interval within one program or there is no interval between programs, the system may not stop in the desired or expected location.

**SCAN SCAN tuning:**

Push the SCAN tuning button while playing a tape, and it will stop at the next tape program for 5 seconds. Pushing the button again during this 5 second period will stop SCAN tuning and the tape program is continued. If the SCAN tuning button is not pushed within 5 seconds, SCAN tuning moves to the next tape program.



### Dolby NR (Noise Reduction) (Type B only):

Push the Dolby NR  button for Dolby NR encoded tapes to reduce high frequency tape noise. The indicator will come on.

Dolby noise reduction manufactured under license from Dolby Laboratories Licensing Corporation. Dolby NR and the double-D symbol  are trademarks of Dolby Laboratories Licensing Corporation.

### Metal or chrome tape usage:

The cassette player will be automatically set to high performance play when playing a metal or chrome cassette tape.



### TAPE EJECT:

When this button is pushed with the tape loaded, the tape will be ejected.

When the tape is ejected while it is being played, the system will be turned off.

### Compact disc (CD) changer operation

Turn the ignition key to the ACC or ON position, push the LOAD button and insert the compact disc into the slot with the label side facing up. The compact disc will be guided automatically into the slot and start playing.

After loading the disc, the number of tracks on

the disc and the play time will appear on the display.

If the radio or tape is already operating, it will automatically turn off and the compact disc will play.



### CAUTION

**Do not force the compact disc into the slot. This could damage the player.**

If the system has been turned off while the compact disc was playing, pushing the ON-OFF/VOL control knob will start the compact disc.

3.1 in (8 cm) diameter compact discs can also be used without an adapter.

### LOAD CD LOAD:

To insert a CD in the CD changer, push the LOAD button for less than 1.5 seconds. Select the loading slot by pushing the CD insert select button (1 to 6), then insert the CD.

To insert 6 CDs to the CD changer in succession, push the LOAD button for more than 1.5 seconds.

The inserted slot numbers will illuminate on the display.



### DISC PLAY:

When the DISC (CD play) button is pushed with the system off and the compact disc loaded, the system will turn on and the compact disc will start to play.

When the DISC button is pushed with the compact disc loaded with the tape or the radio playing, the tape or radio will automatically be turned off and the compact disc will start to play.



### FF (Fast Forward), REW (Rewind):

When the  (fast forward) or  (rewind) button is pushed while the compact disc is being played, the compact disc will play while fast forwarding or rewinding. When the button is released, the compact disc will return to normal play speed.



### APS (Automatic Program Search) FF, APS REW:

When the  (APS FF) button is pushed while the compact disc is being played, the program after the present one will start to play from its beginning. Push several times to skip through programs. The compact disc will advance the number of times the button is pushed. (When the last program on the compact disc is skipped through, the first program

will be played.) When the **↵** (APS REW) button is pushed, the program being played returns to its beginning. Push several times to skip back through programs. The compact disc will go back the number of times the button is pushed.

### CD PLAY select button:

To change CD, push the CD play select button (1 to 6).

### SCAN SCAN tuning:

When the SCAN tuning button is pushed for less than 1.5 seconds while the CD is being played, the beginning of all the CD programs in each track will be played for 10 seconds in sequence.

When the SCAN tuning button is pushed for more than 1.5 seconds while the CD is being played, the first program in all the CDs will be played for 10 seconds.

Pushing the button again during this 10 second period will stop SCAN tuning.

If the SCAN tuning button is not pushed within 10 seconds, SCAN tuning moves to the next disc program.

### RPT REPEAT (RPT):

When the RPT button is pushed while the

compact disc is played, the play pattern can be changed as follows:

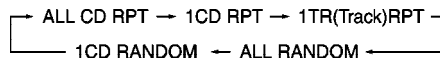

### CD EJECT:

When the CD EJECT button is pushed with the compact disc loaded, the compact disc will be ejected.

To eject the discs selected by the CD select button, push the EJECT button for less than 1.5 seconds.

To eject all the discs, push the EJECT button for more than 1.5 seconds.

When this button is pushed while the compact disc is being played, the compact disc will come out and the system will turn off.

**If the compact disc comes out and is not removed, it will be pulled back into the slot to protect it. (except 3.1 in (8 cm) diameter compact discs)**

### CD IN indicator:

CD IN indicator appears on the display when the CD is loaded with the system on.

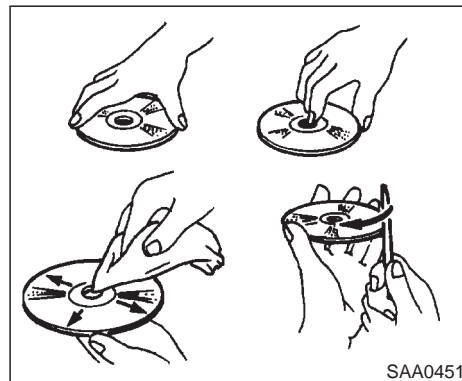

## CD CARE AND CLEANING

- Handle a CD by its edges. Never touch the surface of the disc. Do not bend the disc.
- Always place the discs in the storage case when they are not being used.
- To clean a disc, wipe the surface from the center to the outer edge using a clean, soft cloth. Do not wipe the disc using a circular motion. Do not use a conventional record cleaner or alcohol intended for industrial use.
- A new disc may be rough on its inner and outer edges. Remove the rough edges using the side of a pen or pencil as illustrated.

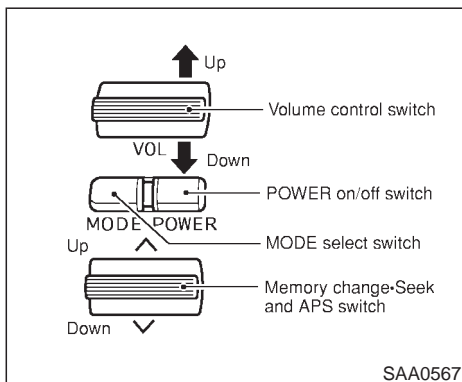

## STEERING SWITCH FOR AUDIO CONTROL (if so equipped)

The audio system can be operated using the controls on the steering wheel.

### POWER on/off switch

With the ignition key turned to the ACC or ON position, push the POWER switch to turn the audio system on or off.

### MODE select switch

Push the mode select switch to change the mode in the sequence of AM, FM1, FM2,



SAT1 (if so equipped), SAT2 (if so equipped), CD and Tape.

### Volume control switches



Push the volume control switch to increase or decrease the volume.





### Memory change (radio):

Push the tuning switch  or  for less than 1.5 seconds to change the radio frequency.

### Seek tuning (radio):

Push the tuning switch  or  for more than 1.5 seconds to seek the next or previous radio station.



### APS (Automatic Program Search) FF, APS REW (tape and CD):



Push the tuning switch  or  for less than 1.5 seconds to return to the beginning of the present program or skip to the next program. Push several times to skip back or skip through programs.

This system searches for the blank intervals between selections. If there is a blank interval within one program or there is no interval between programs, the system may not stop in

the desired or expected location.

### FF REW (tape or CD):

Push the tuning switch  or  for more than 1.5 seconds to rewind or fast forward the tape or to change the playing disc up or down.

To stop the FF or REW function, press the  or  button for more than 1.5 seconds again.

## ANTENNA

### Window antenna

The antenna pattern is printed inside the rear window.



## CAUTION

- Do not place metalized film near the rear window glass or attach any metal parts to it. This may cause poor reception or noise.
- When cleaning the inside of the rear window, be careful not to scratch or damage the rear window antenna. Lightly wipe along the antenna with a dampened soft cloth.

Satellite radio antenna (if so equipped)

Satellite radio performance may be affected if cargo carried on the roof rack blocks the satellite radio signal. If possible, do not put cargo over the satellite radio antenna.

## CAR PHONE OR CB RADIO

When installing a CB, ham radio or car phone in your INFINITI, be sure to observe the following cautions, otherwise the new equipment may adversely affect the Engine control system and other electronic parts.



### WARNING

- A cellular telephone should not be used while driving so full attention may be given to vehicle operation. Some jurisdictions prohibit the use of cellular telephones while driving.
- If you must make a call while your vehicle is in motion, the hands free cellular phone operational mode (if so equipped) is highly recommended. Exercise extreme caution at all times so full attention may be given to vehicle operation.
- If a conversation in a moving vehicle requires you to take notes, pull off the road to a safe location and stop your vehicle before doing so.



### CAUTION

- Keep the antenna as far as possible away from the Engine Control Module (ECM).
- Keep the antenna wire more than 8 in (20 cm) away from the Multiport Fuel Injection harness. Do not route the antenna wire next to any harness.
- Adjust the antenna standing-wave ratio as recommended by the manufacturer.
- Connect the ground wire from the CB radio chassis to the body.
- For details, consult an authorized INFINITI dealer.

# 5 Starting and driving

Precautions when starting and driving.....	5-2	Cruise control operations .....	5-17
Exhaust gas (Carbon monoxide).....	5-2	Break-in schedule .....	5-18
Three way catalyst .....	5-3	Increasing fuel economy .....	5-19
Low tire pressure warning system .....	5-3	AWD warning light (if so equipped) .....	5-19
Avoiding collision and rollover.....	5-4	Parking/parking on hills.....	5-21
Drinking alcohol/drugs and driving.....	5-5	Power steering .....	5-22
AWD driving safety precautions.....	5-5	Brake system .....	5-22
Ignition switch.....	5-6	Braking precautions.....	5-22
Automatic transmission .....	5-6	Anti-lock brake system (ABS) .....	5-23
Manual transmission .....	5-7	Vehicle dynamic control (VDC) system .....	5-24
Key positions .....	5-7	Cold weather driving .....	5-26
INFINITI Vehicle Immobilizer System .....	5-8	Freeing a frozen door lock.....	5-26
Before starting the engine.....	5-8	Antifreeze .....	5-26
Starting the engine.....	5-9	Battery .....	5-26
Driving the vehicle.....	5-9	Draining of coolant water .....	5-26
Automatic transmission .....	5-9	Tire equipment .....	5-26
Manual transmission .....	5-14	Special winter equipment .....	5-27
Parking brake .....	5-15	Driving on snow or ice .....	5-27
Cruise control .....	5-16	Engine block heater (if so equipped) .....	5-27
Precautions on cruise control.....	5-17		

## PRECAUTIONS WHEN STARTING AND DRIVING



### WARNING

- Do not leave children, impaired adults, or pets alone in your vehicle. They could accidentally injure themselves or others through inadvertent operation of the vehicle. Also, on hot, sunny days, temperatures in a closed vehicle could quickly become high enough to cause severe or possibly fatal injuries to people or animals.
- Closely supervise children when they are around cars to prevent them from playing and becoming locked in the trunk where they could be seriously injured. Keep the car locked with the trunk closed when not in use, and prevent children's access to car keys.

## EXHAUST GAS (Carbon monoxide)



### WARNING

Do not breathe exhaust gas; it contains colorless and odorless carbon mon-

oxide. Carbon monoxide is dangerous. It can cause unconsciousness or death.

- If you suspect that exhaust fumes are entering the vehicle, drive with all windows fully open, and have the vehicle inspected immediately.
- Do not run the engine in closed spaces such as a garage.
- Do not park the vehicle with the engine running for an extended period of time.
- Keep the trunk lid closed while driving, otherwise exhaust gas could be drawn into the passenger compartment. If you must drive with the trunk lid open, follow these precautions:
  - Open all the windows.
  - Set the air recirculation switch OFF and the fan control at high to circulate the air.
- If electrical wirings or other cable

connections must pass to a trailer through the seal of the trunk lid or the body, follow the manufacturer's recommendation to prevent carbon monoxide entry into the vehicle.

- If a special body or other equipment is added for recreational or other usage, follow the manufacturer's recommendation to prevent carbon monoxide entry into the vehicle. (Some recreational vehicle appliances such as stoves, refrigerators, heaters, etc. may also generate carbon monoxide.)
- The exhaust system and body should be inspected by a qualified mechanic whenever:
  - Your vehicle is raised while being serviced.
  - You suspect that exhaust fume is entering into the passenger compartment.
  - You notice a change in the sound of the exhaust system.



- You have had an accident involving damage to the exhaust system, underbody, or rear of the vehicle.

## THREE WAY CATALYST

The three way catalyst is an emission control device installed in the exhaust system. Exhaust gas in the converter is burned at high temperatures to help reduce pollutants.



## WARNING

- The exhaust gas and the exhaust system are very hot. Keep people, animals or flammable materials away from the exhaust system components.
- Do not stop or park the vehicle over flammable materials such as dry grass, waste paper or rags. They may ignite and cause fire.



## CAUTION

- Do not use leaded gasoline. Deposits from leaded gasoline seriously reduce the three way catalyst's ability to help reduce exhaust pollutants.
- Keep your engine tuned up. Malfunctions in the ignition, fuel injection, or electrical systems may cause over-rich fuel flow into the three way catalyst, causing it to overheat. Do not keep driving if the engine misfires, or if noticeable loss of performance or other unusual operating conditions are detected. Have the vehicle inspected promptly by an authorized INFINITI dealer.
- Avoid driving with an extremely low fuel level. Running out of fuel could cause the engine to misfire, damaging the three way catalyst.
- Do not race the engine while warming it up.
- Do not push or tow your vehicle to start the engine.

## LOW TIRE PRESSURE WARNING SYSTEM

The low tire pressure warning system monitors pressure of all tires (except the spare tire) by sending a signal from a sensor that is installed in each wheel.

Tire pressure rises and falls depending on the heat caused by the vehicle's operation and the outside temperature. Low outside temperature can lower the temperature of the air inside the tire which can cause a lower tire inflation pressure. This may cause the low tire pressure warning light to illuminate.

If the warning light illuminates in low ambient temperatures as described above, check the tire pressure for all four tires. Adjust the tire pressure to the recommended COLD tire pressure shown on the Tire and Loading Information label to turn the low tire pressure warning light OFF.

The low tire pressure warning system will activate only when the vehicle is driven at speeds above 20 MPH (32 km/h). Also, this system may not detect a sudden drop in tire pressure (for example, a flat tire while driving).

Frequently check the tire pressure and adjust the pressure of each tire properly.

## Low tire pressure warning

If the vehicle is being driven with an extremely low tire pressure (lower than 25 psi: Sedan / 28 psi: Coupe), the low tire pressure warning light comes on, and the chime sounds for about 10 seconds.

For additional information regarding the above warning, see “Warning/indicator lights and audible reminders” in the “2. Instruments and controls” section.



### WARNING

- If the low tire pressure warning light in the meter panel comes on while driving, avoid sudden steering maneuvers or abrupt braking, reduce vehicle speed, pull off the road to a safe location and stop the vehicle as soon as possible. Serious vehicle damage could occur and may lead to an accident and could result in serious personal injury. Check the pressure for all four tires. Adjust the tire pressure to the recommended COLD tire pressure shown on the Tire and Loading Information label to turn the

low tire pressure warning light OFF. If you have a flat tire, replace it with a spare tire as soon as possible. (See “Flat tire” in the “6. In case of emergency” section for changing a flat tire.)

- When a spare tire is mounted or a wheel is replaced, the low tire pressure warning system will not function. Contact your INFINITI dealer as soon as possible for tire replacement and/or system resetting.
- Do not inject any tire liquid or aerosol tire sealant into the tires, as this may cause a malfunction of the tire pressure sensors.



### CAUTION

Do not place metalized film or any metal parts (antenna, etc.) on the windows. This may cause poor reception of the signals from the tire pressure sensors, and the low tire pressure warning sys-

tem will not function properly.

### FCC Notice:

Changes or modifications not expressly approved by the manufacturer compliance could void the user’s authority to operate the equipment.

This device complies with Part 15 of the FCC Rules and RSS-210 of Industry Canada.

Operation is subject to the following two conditions: (1) This device may not cause harmful interference, and (2) this device must accept any interference received, including interference that may cause undesired operation of the device.

### AVOIDING COLLISION AND ROLLOVER



### WARNING

Failure to operate this vehicle in a safe and prudent manner may result in loss of control or an accident.

Be alert and drive defensively at all times. Obey all traffic regulations. Avoid excessive speed, high speed cornering, or sudden steering maneuvers. These driving practices could cause you to lose control of your vehicle. **As with any vehicle, a loss of control could result in a collision with other vehicles or objects, or cause the vehicle to rollover, particularly if the loss of control causes the vehicle to slide sideways.** Be attentive at all times, and avoid driving when tired. Never drive under the influence of alcohol or drugs (including prescription or over-the-counter drugs which may cause drowsiness). Always wear your seat belt. See “Seat belts” in the “1. Safety — Seats, restraints and supplemental air bags” section. Also instruct your passengers to do so.

Seat belts help reduce the risk of injury in collisions and rollovers. In a rollover crash, an unbelted or improperly belted person is significantly more likely to be injured or killed than a person wearing a seat belt.

## DRINKING ALCOHOL/DRUGS AND DRIVING



### WARNING

**Never drive under the influence of alcohol or drugs. Alcohol in the bloodstream reduces coordination, delays reaction time and impairs judgment. Driving after drinking alcohol increases the likelihood of being involved in an accident injuring yourself and others. Additionally, if you are injured in the accident, alcohol can increase the severity of the injury.**

INFINITI is committed to safe driving. You must not drive under the influence of alcohol. Every year thousands of people are injured or killed in alcohol related accidents. Although the local laws vary on what is considered to be legally intoxicated, the fact is that alcohol affects all people differently and most people underestimate the effects of alcohol.

Remember, drinking and driving don't mix!

And that's true for drugs too (over the counter, prescription, and illegal drugs). Don't drive if

your ability to operate your vehicle is impaired by alcohol, drugs, or some other physical condition.

## AWD DRIVING SAFETY PRECAUTIONS



### WARNING

- **Do not drive beyond the performance of the tires, even with AWD engaged. Accelerating quickly, sharp steering maneuvers or sudden braking may cause loss of control.**
- **Always use tires of the same type, size, brand, construction (bias, bias-belted or radial), and tread pattern on all four wheels. Install tire chains on the rear wheels when driving on slippery roads and drive carefully.**
- **This vehicle is not designed for off-road (rough road) use. Do not drive on sandy or muddy roads that tires may get stuck in.**
- **Do not place an AWD equipped vehicle on a two wheel dynamometer or**

raise two wheels off the ground and shift the transmission to any D (drive) or R (reverse) position. Doing so may result in transmission damage or unexpected vehicle movement which could result in serious vehicle damage or personal injury.

- Never operate the accelerator pedal with any wheels raised and the other wheels on the ground while jacking up or with any wheels on a roller and the other wheels on the ground. Otherwise, the vehicle could lurch forward or backward.
- When a wheel is off the ground due to an unlevel surface, do not spin the wheel excessively.

## IGNITION SWITCH

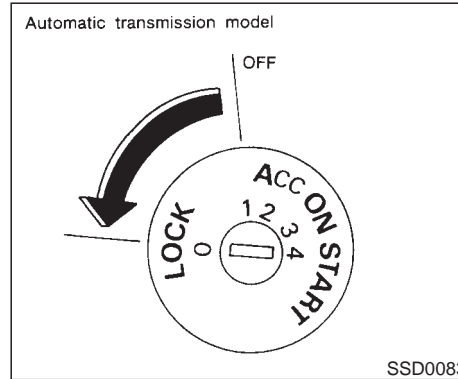

## AUTOMATIC TRANSMISSION

The ignition switch includes an anti-theft steering lock device. On automatic transmission models, the ignition lock is designed so that the key cannot be turned to LOCK and removed until the selector lever is moved to the P position.

If the selector lever is not returned to P position, the key cannot be moved toward LOCK.

When removing the key from the ignition, make sure the selector lever is in the P position.

When the key cannot be turned toward the

LOCK position, proceed as follows to remove the key:

1. Move the selector lever into the P position.
2. Turn the ignition key slightly in the ON direction.
3. Turn the key toward the LOCK position.
4. Remove the key.

If the key is removed from the ignition switch, the selector lever cannot be moved from the P position. **The selector lever can be moved if the ignition switch is in the ON position and the foot brake pedal is depressed.**

There is an OFF position in between LOCK and ACC, although it does not show on the lock cylinder. When the ignition is in OFF the steering wheel is not locked.

In order to lock the steering wheel, it must be turned about 1/6 of a turn counterclockwise from the straight up position.

**To lock the steering wheel, turn the key to the LOCK position. Remove the key.**

**To unlock the steering wheel, insert the key and turn it gently while rotating the steering wheel slightly right and left.**



## WARNING

Never remove or turn the key to the LOCK position while driving. The steering wheel will lock. This may cause the driver to lose control of the vehicle and could result in serious vehicle damage and/or personal injury.

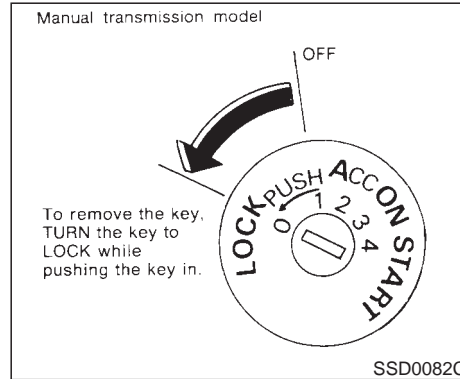

## MANUAL TRANSMISSION

The ignition switch includes an anti-theft steering lock device.

On manual transmission models, the ignition lock is designed so that the key cannot be turned to LOCK and removed unless the key is pushed in while turning the key between ACC and LOCK.

In order for the steering wheel to be locked, it must be turned about 1/6 of a turn clockwise from the straight up position.

**To lock the steering wheel, turn the key to the LOCK position. Remove the key.**

**To unlock the steering wheel, insert the key and turn it gently while rotating the steering wheel slightly right and left.**



## WARNING

Never remove or turn the key to the LOCK position while driving. The steering wheel will lock. This may cause the driver to lose control of the vehicle and could result in serious vehicle damage and/or personal injury.

## KEY POSITIONS

The ignition switch includes an anti-theft steering lock device.

LOCK (Normal parking position) (0)

The ignition key can only be removed when the ignition switch is in this position.

OFF (1)

The engine can be turned off without locking the steering wheel.

The ignition lock is designed so that the key cannot be turned to LOCK and removed until the selector lever is moved to the P position (for automatic transmission) or the key is

pushed in while turning the key between ACC and LOCK.

#### ACC (Accessories) (2)

This position activates electrical accessories when the engine is not running.

#### ON (Normal operating position) (3)

This position activates ignition system in addition to electrical accessories.

#### START (4)

This position activates the starter motor, starting the engine.

### INFINITI VEHICLE IMMOBILIZER SYSTEM

The INFINITI Vehicle Immobilizer System will not allow the engine to start without the use of the registered INFINITI Vehicle Immobilizer System key.

If the engine fails to start using the registered INFINITI Vehicle Immobilizer System key, it may be due to interference caused by another INFINITI Vehicle Immobilizer System key, an automated toll road device or automated payment device on the key ring. Restart the engine using the following procedures:

1. Leave the ignition switch in the ON position for approximately 5 seconds.
2. Turn the ignition switch to the OFF or LOCK position and wait approximately 10 seconds.
3. Repeat steps 1 and 2 again.
4. Restart the engine while holding the device (which may have caused the interference) away from the registered INFINITI Vehicle Immobilizer System key.

If this procedure allows the engine to start, INFINITI recommends placing the registered INFINITI Vehicle Immobilizer System key on a separate key ring to avoid interference from other devices.

### BEFORE STARTING THE ENGINE

- Make sure the area around the vehicle is clear.
- Make sure the periodical maintenance is being performed.
- Make sure all windows and lights are clean.
- Make sure of the proper inflation of tires and their conditions.
- Make sure to lock all doors.
- Make sure to adjust seats and head restraints.
- Make sure to adjust inside and outside mirrors.
- Make sure to fasten seat belts and direct all passengers to do likewise.
- Make sure to check the operation of warning lights when the key is turned to the ON (3) position.

## STARTING THE ENGINE

1. Apply the parking brake.

### 2. Automatic transmission:

Move the selector lever to P or N. (P preferred.)

The starter is designed so that the starter does not operate unless the selector lever is in either one of the above positions.

### Manual transmission:

Move the shift lever to the N position. Depress the clutch pedal fully to the floor.

The starter is designed so that it does not operate unless the clutch pedal is fully depressed.

3. Turn the ignition switch to START (4) to crank the engine **with your foot off the accelerator pedal**. Release the key when the engine starts.

If the engine starts, but fails to run, repeat the above procedure.

- If the engine is very hard to start in extremely cold weather or when restarting, depress the accelerator pedal a little (approximately 1/3 to the floor) and while holding, crank the engine. Release the key and the accelerator pedal when the engine starts.

- If the engine is very hard to start because it is flooded, depress the accelerator pedal all the way to the floor and hold it. Crank the engine for 5 to 6 seconds. After cranking the engine, release the accelerator pedal. Crank the engine **with your foot off the accelerator pedal** by turning the ignition key to START. Release the key when the engine starts, but fails to run, repeat the above procedure.



## CAUTION

**Do not operate the starter for more than 15 seconds at a time. If the engine does not start, turn the key off and wait 10 seconds before cranking again, otherwise the starter could be damaged.**

### 4. Warm-up

Allow the engine to idle for at least 30 seconds after starting. Do not race the engine while warming it up. Drive at moderate speed for a short distance first, especially in cold weather. In cold weather, keep the engine running for a minimum of 2 - 3 minutes before shutting it off. Starting and stopping the engine over a short period of time may make the vehicle more difficult to start.

## DRIVING THE VEHICLE

### AUTOMATIC TRANSMISSION

#### 5 speed automatic transmission

The automatic transmission in your vehicle is electronically controlled by a transmission control module to produce maximum efficiency and smooth operation.

Shown on the following pages are the recommended operating procedures for this transmission. Follow these procedures for maximum vehicle performance and driving enjoyment.

#### Starting the vehicle

After starting the engine, fully depress the foot brake pedal and push the selector lever button before shifting the selector lever to the R (Reverse), N (Neutral), D (Drive) or Manual shift mode position. Be sure the vehicle is fully stopped before attempting to shift the selector lever.

**This automatic transmission model is designed so that the foot brake pedal must be depressed before shifting from P (Park) to any drive position while the ignition switch is ON.**

**The selector lever cannot be moved out of the P (Park) position and into any of the other gear positions if the ignition key is**

turned to the **LOCK, OFF** or **ACC** position or if the key is removed from the switch.

1. Keep the foot brake pedal depressed and push the selector lever button to shift into a driving gear.
2. Release the parking brake and foot brake, then gradually start the vehicle in motion.



## **WARNING**

- Do not depress the accelerator pedal while shifting from P (Park) or N (Neutral) to R (Reverse), D (Drive) or manual shift mode. Always depress the brake pedal until shifting is complete. Failure to do so could cause you to lose control and have an accident.
- Cold engine idle speed is high, so use caution when shifting into a forward or reverse gear before the engine has warmed up.
- On slippery roads, do not downshift. This may cause a loss of control.
- Never shift to P (Park) or R (Reverse)

while vehicle is moving forward. Never shift to P (Park) or D (Drive) while vehicle is moving rearward. These could cause you to lose control and have an accident.



## **CAUTION**

When stopping the vehicle on an uphill grade, do not hold the vehicle by depressing the accelerator pedal. The foot brakes should be used for this purpose.



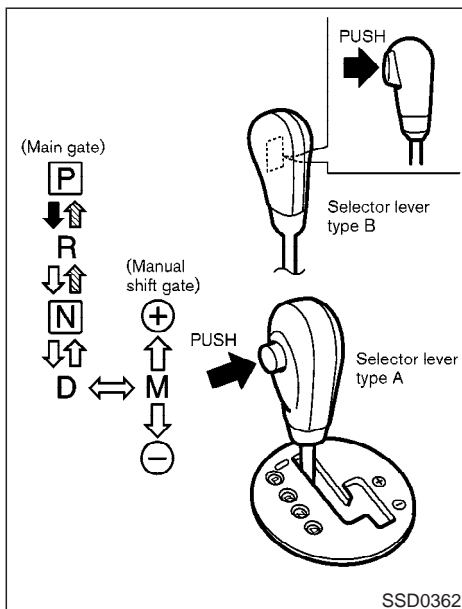

To move the selector lever,

- : Push the button while depressing the brake pedal,
- : Push the button,
- : Just move the selector lever.

## Shifting

After starting the engine, fully depress the brake pedal and shift the selector lever from P (Park) to R (Reverse), N (Neutral), D (Drive), or Manual shift mode position.

Push the button to shift into P (Park) or R (Reverse). All other positions can be selected without pushing the button.



### WARNING

Apply the parking brake if the selector lever is in any position while the engine is not running. Failure to do so could cause the vehicle to move unexpectedly or roll away and result in serious personal injury and/or property damage.

If the key is turned to OFF or ACC for any reason while the vehicle is in R (Reverse), N (Neutral), or any D (Drive) position, the key cannot be turned to LOCK and be removed from the ignition switch. Move the selector lever to P (Park) position, then the key can be turned to LOCK.

P (Park):

Use this selector position when the vehicle is

parked or when starting the engine. Make sure the vehicle is completely stopped. **The brake pedal must be depressed and the selector lever button pushed in to move the selector lever from N (Neutral) or any drive position to P (Park).** Apply the parking brake. When parking on a hill, apply the parking brake first, then move the lever to the P (Park) position.



### CAUTION

Use this position only when the vehicle is completely stopped.

R (Reverse):

Use this position to back up. Always be sure the vehicle is completely stopped before selecting R (Reverse). **The brake pedal must be depressed and the selector lever button pushed in to move the selector lever from P (Park), N (Neutral) or any drive position to R (Reverse).**

N (Neutral):

Neither forward nor reverse gear is engaged. The engine can be started in this position. You may shift to N (Neutral) and restart a stalled engine while the vehicle is moving.

D (Drive):

Use this position for all normal forward driving.

## Manual shift mode

When the selector lever is shifted from D to the manual shift gate with the vehicle stopped or while driving, the transmission enters the manual shift mode. Shift range can be selected manually.

In the manual shift mode, the shift range is displayed on the position indicator in the meter.

Shift ranges up or down one by one as follows:

1<sup>M</sup> → 2<sup>M</sup> → 3<sup>M</sup> → 4<sup>M</sup> → 5<sup>M</sup>  
← ← ← ← ←

5<sup>M</sup> (5th):

Use this position for all normal forward driving.

4<sup>M</sup> (4th):

For driving up or down long slopes where engine braking would be advantageous.

3<sup>M</sup> (3rd) and 2<sup>M</sup> (2nd):

Use for hill climbing or engine braking on downhill grades.

1<sup>M</sup> (1st):

Use this position when climbing steep hills

slowly or driving slowly through deep snow, sand or mud, or for maximum engine braking on steep downhill grades.

- Remember not to drive at high speeds for extended periods of time in lower than 4<sup>M</sup> range. This reduces gas mileage.
- When shifting up, move the selector lever to the + (up) side. (Shifts to higher range.)
- When shifting down, move the selector lever to the – (down) side. (Shifts to lower range.)
- Moving the selector lever rapidly to the same side twice will shift the ranges in succession.
- When canceling the manual shift mode, return the selector lever to the D position. The transmission returns to the normal driving mode.
- **In the manual shift mode, the transmission may not shift to the selected gear. This helps maintain driving performance and reduces the chance of vehicle damage or loss of control.**

**Sedan — type A:**

- **In the manual shift mode, the transmission may shift up automatically over the selected range, if the engine is revved**

**up to a hazardous speed. When vehicle speed decreases, the transmission automatically shifts down and shifts to 1st gear before the vehicle comes to a stop.**

**Sedan — type B and Coupe:**

**In the manual shift mode, the transmission automatically shifts down to 1st gear before the vehicle comes to a stop. When accelerating again, it is necessary to shift up to the desired range.**

## Accelerator downshift

— In D position —

For passing or hill climbing, fully depress the accelerator pedal to the floor. This shifts the transmission down into the lower gear, depending on the vehicle speed.

## Fail-safe

When the fail-safe operation occurs, the next time the key is turned to the ON position, the <sup>AT</sup> <sub>CHECK</sub> light will blink for approximately 8 seconds after coming on for 2 seconds. While the vehicle can be driven under these circumstances please note that the gears in the automatic transmission will be locked in 4th gear.

**If the vehicle is driven under extreme conditions, such as excessive wheel spinning**

and subsequent hard braking, the fail-safe system may be activated. This will occur even if all electrical circuits are functioning properly. In this case, turn the ignition key OFF and wait for 3 seconds. Then turn the key back to the ON position. The vehicle should return to its normal operating condition. If it does not return to its normal operating condition, have your INFINITI dealer check the transmission and repair if necessary.

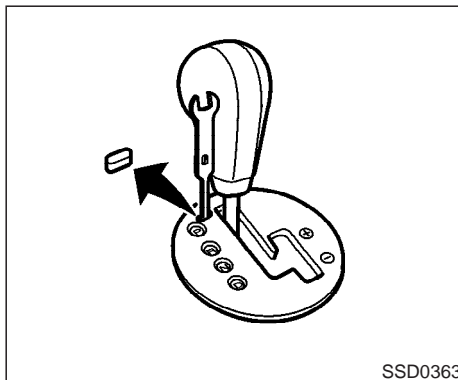

transmission system as soon as possible.

### Shift lock release

If the battery charge is low or discharged, the selector lever may not be moved from the P (Park) position even with the brake pedal depressed.

To move the selector lever, apply the parking brake, depress the brake pedal, and push the shift lock release button. The selector lever can be moved to N (Neutral). This allows the vehicle to be moved if the battery is discharged.

If the lever cannot be moved out of P (Park), have your INFINITI dealer check the automatic

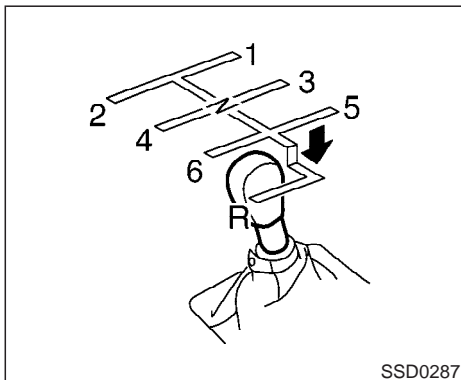

## MANUAL TRANSMISSION

### Shifting

To change gears, or when up shifting or down shifting fully depress the clutch pedal, shift into the appropriate gear then slowly and smoothly release the clutch.

This vehicle is equipped with a short throw shifter manual transmission. To ensure smooth gear changes, fully depress the clutch pedal before operating the shift lever. If the clutch pedal is not fully depressed before the transmission is shifted, a gear noise may be heard. Transmission damage could occur.

### 5-14 Starting and driving

Start the vehicle in 1st gear and shift to 2nd, 3rd, 4th, 5th and 6th gear in sequence according to the vehicle speed.

To back up, depress the shift lever and then move it to the R (Reverse) position after stopping the vehicle completely.

If it is difficult to move the shift lever into R (Reverse) or 1 (Low gear), shift to N (Neutral), and then release the clutch pedal once. Fully depress the clutch pedal again and shift into R or 1.



### WARNING

- Do not downshift abruptly on slippery roads. This may cause a loss of control.
- Do not over-rev the engine when shifting to a lower gear. This may cause a loss of control or engine damage.



### CAUTION

- Do not rest your foot on the clutch pedal while driving. This may damage the clutch.
- Fully depress the clutch pedal before shifting to help prevent transmission damage.
- Stop your vehicle completely before shifting into R (Reverse).
- When the vehicle is stopped for a period of time, for example at a stop light, shift to N (Neutral) and release the clutch pedal with the foot brake applied.

### Suggested up-shift speeds

Shown below are suggested vehicle speeds for shifting into a higher gear. These suggestions relate to fuel economy and vehicle performance. Actual up-shift speeds will vary according to road conditions, the weather and individual driving habits.

For normal acceleration in low altitude areas [less than 4,000 ft (1,219 m)]:

Gear change	MPH (km/h)
1st to 2nd	8 (13)
2nd to 3rd	16 (26)
3rd to 4th	25 (40)
4th to 5th	28 (45)
5th to 6th	33 (53)

For quick acceleration in low altitude areas or in high altitude areas [over 4,000 ft (1,219 m)]:

Gear change	MPH (km/h)
1st to 2nd	15 (24)
2nd to 3rd	25 (40)
3rd to 4th	40 (64)
4th to 5th	45 (72)
5th to 6th	50 (80)

### Suggested maximum speed in each gear

Downshift to a lower gear if the engine is not running smoothly, or if you need to accelerate.

Do not exceed the maximum suggested speed (shown below) in any gear. For level road driving, use the highest gear suggested for that speed. Always observe posted speed limits, and drive according to the road conditions, which will ensure safe operation. Do not

over-rev the engine when shifting to a lower gear as it may cause engine damage or loss of vehicle control.

Gear	MPH (km/h)
1st	35 (56)
2nd	60 (96)
3rd	85 (136)
4th	—
5th	—
6th	—

## PARKING BRAKE

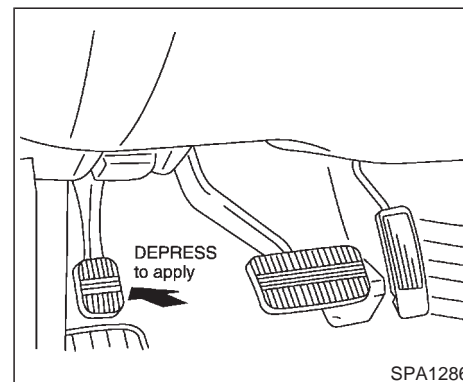

### Automatic transmission model

**To apply:** Fully depress the parking brake pedal.

### To release:

1. Firmly apply the foot brake.
2. Depress the parking brake pedal and the parking brake will be released.
3. Before driving, be sure the brake warning light goes out.

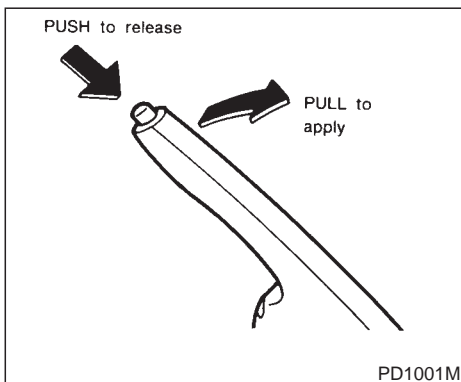

### Manual transmission model

**To apply:** Pull the lever up.

**To release:**

1. Firmly apply foot brake.
2. While pulling up on the lever slightly, push the button and lower completely.
3. Before driving, be sure the brake warning light goes out.



### WARNING

- Be sure the parking brake is fully released before driving. Failure to do so can cause brake failure and lead to an accident.
- Do not release the parking brake from outside the vehicle.
- Do not use the gear shift in place of the parking brake. When parking, be sure the parking brake is fully engaged.
- Do not leave children unattended in a vehicle. They could release the parking brake and cause an accident.

## CRUISE CONTROL



### WARNING

Do not use the cruise control when driving under the following conditions:

- it is not possible to keep the vehicle at a set speed.
- in heavy traffic or in traffic that varies in speed.
- on winding or hilly roads.
- on slippery roads (rain, snow, ice, etc.).
- in very windy areas.

Doing so could cause a loss of vehicle control and result in an accident.



### CAUTION

On manual transmission models, do not shift into N (Neutral) without depressing the clutch pedal when the cruise control is set. Should this occur, depress the clutch pedal and turn the main switch off immediately. Failure to do so may cause

engine damage.

## PRECAUTIONS ON CRUISE CONTROL

- If the cruise control system malfunctions, it cancels automatically. The SET indicator light on the meter panel then blinks to warn the driver.
- If the engine coolant temperature becomes excessively high, the cruise control system will be canceled automatically.
- If the SET indicator light blinks, turn the cruise control main switch off and have the system checked by your INFINITI dealer.
- The SET indicator light may blink when the cruise control main switch is turned on while pushing the RES/ACCEL, COAST/SET, or CANCEL switch (located on the steering wheel). To properly set the cruise control system, perform the preceding steps in the order indicated.

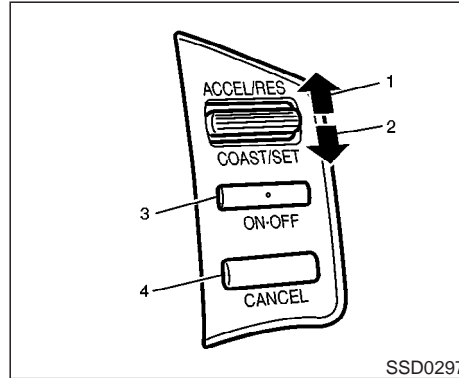

1. RESUME or ACCEL switch
2. COAST or SET switch
3. ON/OFF switch
4. CANCEL switch

## CRUISE CONTROL OPERATIONS

The cruise control allows driving at a speed between 25 to 89 MPH (40 to 144 km/h) without keeping your foot on the accelerator pedal.

**To turn on the cruise control**, push the main switch on. The CRUISE indicator light on the meter panel will come on.

**To set at cruising speed**, accelerate your vehicle to the desired speed, push the COAST/SET switch and release it. (The SET indicator light will come on.) Take your foot off the accelerator pedal. Your vehicle will maintain the set speed.

- **To pass another vehicle**, depress the accelerator pedal. When you release the pedal, the vehicle will return to the previously set speed.
- The vehicle may not maintain the set speed when going up or down steep hills. If this happens, drive without the cruise control.

**To cancel the preset speed**, follow either of these three methods:

- a) Push the cancel switch; The SET indicator light will go out.
  - b) Tap the brake pedal; The SET indicator light will go out.
  - c) Turn the main switch off. Both the CRUISE indicator and SET indicator lights will go out.
- If you depress the brake pedal while pushing the RES/ACCEL set switch and reset at the cruising speed, turn the main switch off once and then turn it on again.
  - The cruise control will automatically be can-

celled if the vehicle slows down below approximately 8 MPH (13 km/h).

- Depress the clutch pedal (manual transmission), or move the selector lever to the N (Neutral) position (automatic transmission). The SET indicator light will go out.

**To reset at a faster cruising speed**, use one of the following three methods:

- a) Depress the accelerator pedal. When the vehicle attains the desired speed, push and release the COAST/SET switch.
- b) Push and hold the RES/ACCEL set switch. When the vehicle attains the speed you desire, release the switch.
- c) Push, then quickly release the RES/ACCEL set switch. Each time you do this, the set speed will increase by about 1 MPH (1.6 km/h).

**To reset at a slower cruising speed**, use one of the following three methods:

- a) Lightly tap the brake pedal. When the vehicle attains the desired speed, push the COAST/SET switch and release it.
- b) Push and hold the COAST/SET switch. Release the switch when the vehicle slows down to the desired speed.

- c) Push, then quickly release the COAST/SET switch. Each time you do this, the set speed will decrease by about 1 MPH (1.6 km/h).

**To resume the preset speed**, push and release the RES/ACCEL set switch. The vehicle will resume the last set cruising speed when the vehicle speed is over 25 MPH (40 km/h).

## 5-18 Starting and driving

## BREAK-IN SCHEDULE



### CAUTION

**During the first 1,200 miles (2,000 km), follow these recommendations to obtain maximum engine performance and ensure the future reliability and economy of your new vehicle. Failure to follow these recommendations may result in shortened engine life and reduced engine performance.**

- Avoid driving for long periods at constant speed, either fast or slow. Do not run the engine over 4,000 rpm.
- Do not accelerate at full throttle in any gear.
- Avoid quick starts.
- Avoid hard braking as much as possible.
- Do not tow a trailer for the first 500 miles (800 km).





## INCREASING FUEL ECONOMY

- Accelerate slowly and smoothly. Maintain cruising speeds with a constant accelerator position.
- Drive at moderate speeds on the highway. Driving at high speed will lower fuel economy.
- Avoid unnecessary stopping and braking. Maintain a safe distance behind other vehicles.
- Use a proper gear range which suits road conditions. On level roads, shift into high gear as soon as possible.
- Avoid unnecessary engine idling.
- Keep your engine tuned up.
- Follow the recommended periodic maintenance schedule.
- Keep the tires inflated at the correct pressure. Low pressure will increase tire wear and waste fuel.
- Keep the front wheels in correct alignment. Improper alignment will cause not only tire wear but also lower fuel economy.
- Air conditioner operation lowers fuel economy. Use the air conditioner only when necessary.
- When cruising at highway speeds, it is

more economical to use the air conditioner and leave the windows closed to reduce drag.

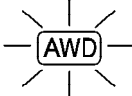
## AWD WARNING LIGHT (if so equipped)

Warning light	Comes on or blinks when
 Comes on	There is a malfunction in the all wheel drive system.
 Blinks rapidly	The power-train oil temperature rises abnormally.
 Blinks slowly	The difference in wheel rotation is large.

SSD0336

The AWD warning light is located in the meter.

The AWD warning light comes on when the key switch is turned to ON. It turns off soon after the engine is started.

If any malfunction occurs in the AWD system

while the engine is running, the warning light will come on.

The warning light may blink rapidly (about twice per second) while trying to free a stuck vehicle due to high power train oil temperature. The driving mode may change to 2 wheel drive. If the warning light blinks rapidly during operation, stop the vehicle with the engine idling in a safe place immediately. Then if the light goes off after a while, you can continue driving.

A large difference between the diameters of front and rear wheels will make the warning light blink slowly (about once per two seconds). Pull off the road in a safe area, and idle the engine. Check that all tire sizes are the same, tire pressure is correct and tires are not worn.

If the warning light is blinking after the above operation, have your vehicle checked by an INFINITI dealer as soon as possible.



## WARNING

- Do not place an AWD equipped vehicle on a two wheel dynamometer or raise two wheels off the ground and shift the transmission to any D (drive) or R (reverse) position. Doing so may result in transmission damage or unexpected vehicle movement which could result in serious vehicle damage or personal injury.
- Do not attempt to test an AWD equipped vehicle with two wheels on a two wheel dynamometer and the other two wheels raised. Doing so may result in transmission damage or unexpected vehicle movement which could result in serious vehicle damage or personal injury.



## CAUTION

- Do not operate the engine on a free roller when any of the wheels are raised.

- If the warning light comes on while driving there may be a malfunction in the AWD system. Reduce the vehicle speed and have your vehicle checked by an INFINITI dealer as soon as possible.
- Never drive on dry hard surface roads in the SNOW mode, as this will overload the power train and may cause a serious malfunction.
- If the warning light remains on after the above operation, have your vehicle checked by an INFINITI dealer as soon as possible.
- The power train may be damaged if you continue driving with the warning light blinking rapidly.

## PARKING/PARKING ON HILLS

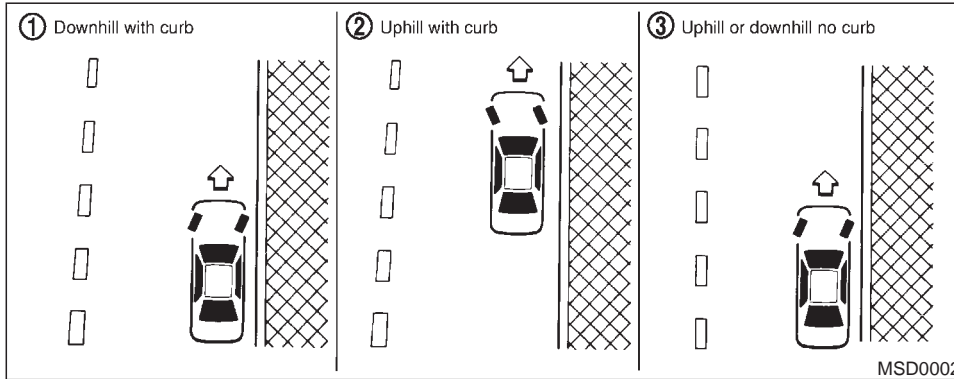

### WARNING

- Do not stop or park the vehicle over flammable materials such as dry grass, waste paper or rags. They may ignite and cause a fire.
- Never leave the engine running while the vehicle is unattended.
- Never leave children unattended in the vehicle.

1. Firmly apply the parking brake.

#### 2. Automatic transmission models:

Move the selector lever to the P (Park) position.

#### Manual transmission models:

Place the shift lever in the R (Reverse) position. When parking on an uphill grade, place the shift lever in the 1 (Low gear) position.



### WARNING

- Safe parking procedures require that both the parking brake be set and the transmission be placed into P (Park) for automatic transmission models or in an appropriate gear for manual transmission models. Failure to do so could cause the vehicle to move unexpectedly or roll away and result in an accident.
- Make sure the automatic transmission selector lever has been pushed as far forward as it can go and cannot be moved without depressing the button at the end of the lever.

3. To help prevent the vehicle from rolling into the street when parked on a sloping drive way, it is a good practice to turn the wheels as illustrated.

#### • HEADED DOWNHILL WITH CURB: ①

Turn the wheels into the curb and move the vehicle forward until the curb side wheel gently touches the curb.

- HEADED UPHILL WITH CURB: ②

Turn the wheels away from the curb and move the vehicle back until the curb side wheel gently touches the curb.

- HEADED UPHILL OR DOWNHILL, NO CURB: ③

Turn the wheels toward the side of the road so the vehicle will move away from the center of the road if it moves.

4. Turn the ignition key to the LOCK position and remove the key.

## POWER STEERING

The power assisted steering is designed to use a hydraulic pump, driven by the engine, to assist steering.

If the engine stops or the drive belt breaks, you will still have control of the vehicle. However, much greater steering effort is needed, especially in sharp turns or at low speeds.



### WARNING

**If the engine is not running or is turned off while driving, the power assist for the steering will not work. Steering will be much harder to operate.**

## BRAKE SYSTEM

### BRAKING PRECAUTIONS

The brake system has two separate hydraulic circuits. If one circuit malfunctions, you will still have braking at two wheels.

#### Vacuum assisted brake

The brake booster aids braking by using engine vacuum. If the engine stops, you can stop the vehicle by depressing the brake pedal. However, greater foot pressure on the brake pedal will be required to stop the vehicle and the stopping distance will be longer.

#### Wet brakes

When the vehicle is washed or driven through water, the brakes may get wet. As a result, your braking distance will be longer and the vehicle may pull to one side during braking.

To dry brakes, drive the vehicle at a safe speed while lightly tapping the brake pedal to heat-up the brakes. Do this until the brakes return to normal. Avoid driving the vehicle at high speeds until the brakes function correctly.

#### Using the brakes

Avoid resting your foot on the brake pedal while driving. This will cause overheating of the brakes, increases wear on the brake linings and pads, and reduces gas mileage.

To help save the brakes and to prevent the brakes from overheating, reduce speed and downshift to a lower gear before going down a slope or long grade. Overheated brakes may reduce braking performance and could result in loss of vehicle control.



## WARNING

- **While driving on a slippery surface, be careful when braking, accelerating or downshifting. Abrupt braking or accelerating could cause the wheels to skid and result in an accident.**
- **If the engine is not running or is turned off while driving, the power assist for the brakes will not work. Braking will be harder.**

## ANTI-LOCK BRAKE SYSTEM (ABS)

The anti-lock brake system controls the brakes at each wheel so the wheels will not lock when braking abruptly or when braking on slippery surfaces. The system detects the rotation speed at each wheel and varies the brake fluid pressure to prevent each wheel from locking and sliding. By preventing wheel lockup, the system helps the driver maintain steering con-

trol and helps to minimize swerving and spinning on slippery surfaces.

## Using the system

Depress the brake pedal and hold it down.



## WARNING

**Do not pump the brake pedal. Doing so may result in increased stopping distances.**

## Normal operation

The anti-lock brake system will not operate at speeds below 3 to 6 MPH (5 to 10 km/h) to stop the vehicle. (The speeds will vary according to road conditions.) When the anti-lock system senses that one or more wheels are close to locking up, the actuator (under the hood) rapidly applies and releases hydraulic pressure (like pumping the brakes very quickly). While the actuator is working, you may feel a pulsation in the brake pedal and hear a noise or vibration from the actuator under the hood. This is normal and indicates that the anti-lock system is working properly. However, the ABS operation may indicate that road conditions are hazardous and extra care

is required while driving.

## Self-test feature

The anti-lock brake system consists of electronic sensors, electric pumps, and hydraulic solenoids controlled by a computer. The computer has a built-in diagnostic feature that tests the system each time you start the engine and move the vehicle at a low speed in forward or reverse. When the self-test occurs, you may hear a clunk noise and/or feel a pulsation in the brake pedal. This is normal and is not an indication of any malfunction. If the computer senses any malfunction, it switches the anti-lock brake system OFF and turns on the ABS warning light in the instrument panel. The brake system will then behave normally, but without anti-lock assistance.

If the light comes on during the self check, or while you are driving, you should take your vehicle to your INFINITI dealer for repair at your earliest convenience.



## WARNING

**The anti-lock brake system is a sophisticated device, but it cannot prevent ac-**

idents resulting from careless or dangerous driving techniques. It can help maintain vehicle control during braking on slippery surfaces, but remember that the stopping distance on slippery surfaces will be longer than on normal surfaces, even with the anti-lock system. Stopping distances may also be longer on rough, gravel or snow covered roads, or if you are using tire chains. Always maintain a safe distance from the vehicle in front of you. Ultimately, the responsibility for safety of yourself and others rests in the hands of the driver.

Tire type and condition of tires may also affect braking effectiveness.

- When replacing tires, install the specified size of tires on all four wheels.
- When installing a spare tire, make sure it is the proper size and type as specified on the Tire and Loading Information label. See “Vehicle identification” in the “9. Technical and

consumer information” section for Tire and Loading Information label location.

## VEHICLE DYNAMIC CONTROL (VDC) SYSTEM

When driving on slippery surfaces or suddenly avoiding obstacles on roads, the vehicle might swerve or slip. With the vehicle dynamic control (VDC) system, sensors detect these movements and control the braking and engine output to help improve vehicle stability while driving.

- When the vehicle dynamic control system is operating, the slip indicator in the instrument panel blinks.
- When only the traction control system (TCS) portion of the vehicle dynamic control system is operating, the slip indicator will also blink.
- If the slip indicator blinks, the vehicle is under slippery conditions. Be sure to drive carefully. See “Slip indicator light”, and “Vehicle dynamic control off indicator light” in the “2. Instruments and controls” section.
- Indicator light  
If a malfunction occurs in the system, the SLIP and  $\overset{\text{VDC}}{\text{OFF}}$  indicator lights come on in the instrument panel.  
As long as these warning lights are on, the traction control function is canceled.

The VDC system uses a Active Brake Limited Slip system to improve vehicle traction. The ABLS system works when one of the

driving wheels is spinning on a slippery surface. The ABLs system brakes the spinning wheel which distributes the driving power to the other drive wheel. If the vehicle is operated with the vehicle dynamic control system turned off, all VDC and TCS functions will be turned off. The ABLs system and ABS will still operate with the VDC system off. If the ABLs system or the ABS is activated, the slip indicator light will blink and you may hear a clunk noise and/or feel a pulsation in the brake pedal. This is normal.

While the VDC system is operating, you may feel a pulsation in the brake pedal and hear a noise or vibration from under the hood. This is normal and indicates that the VDC system is working properly.

The computer has a built in diagnostic feature that tests the system each time you start the engine and move the vehicle forward or in reverse at a slow speed. When the self-test occurs, you may hear a clunk noise and/or feel a pulsation in the brake pedal. This is normal and is not an indication of a malfunction.



## WARNING

- **The vehicle dynamic control system is designed to help improve driving stability but does not prevent accidents due to abrupt steering operation at high speeds or by careless or dangerous driving techniques. Reduce vehicle speed and be especially careful when driving and cornering on slippery surfaces and always drive carefully.**
- **If engine related parts such as muffler are not standard equipment or are extremely deteriorated, the vehicle dynamic control off indicator light and slip indicator light may come on.**
- **If suspension parts such as shock absorbers, struts, springs and bushings are not standard equipment or are extremely deteriorated, the vehicle dynamic control system may**

**not operate properly and the vehicle dynamic control off indicator light may come on.**

- **When driving on extremely inclined surfaces such as higher banked corners, the vehicle dynamic control system may not operate properly or the vehicle dynamic control off indicator light may come on. Do not drive on these types of roads.**
- **If wheels or tires other than the recommended ones are used, the vehicle dynamic control system may not operate properly or the vehicle dynamic control off indicator light may come on.**
- **The vehicle dynamic control system is not a substitute for winter tires or tire chains on a snow covered road.**

## COLD WEATHER DRIVING

### FREEING A FROZEN DOOR LOCK

To prevent a door lock from freezing, apply de-icer or glycerin to it through the key hole. If the lock becomes frozen, heat the key before inserting it into the key hole.

### ANTIFREEZE

In the winter when it is anticipated that the temperature will drop below 32°F (0°C), check antifreeze to assure proper winter protection. For additional information, see “Engine cooling system” in the “8. Maintenance and do-it-yourself” section.

### BATTERY

If the battery is not fully charged during extremely cold weather conditions, the battery fluid may freeze and damage the battery. To maintain maximum efficiency, the battery should be checked regularly. For additional information, see “Battery” in the “8. Maintenance and do-it-yourself” section.

### DRAINING OF COOLANT WATER

If the vehicle is to be left outside without antifreeze, drain the cooling system by opening the drain plug located under the radiator. Refill before operating the vehicle. See “Engine cooling system” in the “8. Maintenance

5-26 Starting and driving

and do-it-yourself” section for changing engine coolant.

### TIRE EQUIPMENT

1. SUMMER tires are of a tread design to provide superior performance on dry pavement. However, the performance of these tires will be substantially reduced in snowy and icy conditions. If you operate your vehicle on snowy or icy roads, INFINITI recommends the use of MUD & SNOW or ALL SEASON tires on all four wheels. Please consult your INFINITI dealer for the tire type, size, speed rating and availability information.
2. For additional traction on icy roads, studded tires may be used. However, some provinces and states prohibit their use. Check local, state and provincial laws before installing studded tires.

**Skid and traction capabilities of studded snow tires, on wet or dry surfaces, may be poorer than that of non-studded snow tires.**

3. Tire chains may be used if desired. Make sure they are of proper size for the tires on your vehicle and are installed according to the chain manufacturer’s suggestions. However, some provinces and states prohibit their use. Check local state and pro-

vincial laws before installing tire chains. **Use only SAE Class S chains.** Class “S” chains are used on vehicles with restricted tire to vehicle clearance. Vehicles that can use Class “S” chains are designed to meet the SAE standard minimum clearances between the tire and the closest vehicle suspension or body component required to accommodate the use of a winter traction device (tire chains or cables). The minimum clearances are determined using the factory equipped tire size. Other types may damage your vehicle. Use chain tensioners when recommended by the tire chain manufacturer to ensure a tight fit. Loose end links of the tire chain must be secured or removed to prevent the possibility of damage to the fenders or underbody. If possible, avoid fully loading your vehicle when using tire chains. In addition, drive at a reduced speed. Otherwise, your vehicle may be damaged and/or vehicle handling and performance may be adversely affected.

- **Never install tire chains on TEMPORARY USE ONLY spare tires.**
- **Do not use tire chains on dry roads.**
- **Tire chains must be installed only on the rear wheels and not on the front wheels.**



Do not drive with tire chains on paved roads which are clear of snow. Driving with chains in such conditions can cause damage to the various mechanisms of the vehicle due to some overstress.

4. For all wheel drive:

If you install snow tires, they must also be the same size, brand, construction and tread pattern on all four wheels.

## SPECIAL WINTER EQUIPMENT

It is recommended that the following items be carried in the vehicle during winter:

- a scraper and stiff-bristled brush to remove ice and snow from the windows and wiper blades.
- a sturdy, flat board to be placed under the jack to give it firm support.
- a shovel to dig the vehicle out of snow-drifts.
- extra window washer fluid to refill the reservoir tank.

## DRIVING ON SNOW OR ICE



### WARNING

- **Wet ice (32°F, 0°C and freezing rain), very cold snow or ice can be slick and very hard to drive on. The vehicle will have a lot less traction or grip under these conditions. Try to avoid driving on wet ice until the road is salted or sanded.**
- **Whatever the condition, drive with caution. Accelerate and slow down with care. If accelerating or downshifting too fast, the drive wheels will lose even more traction.**
- **Allow more stopping distance under these conditions. Braking should be started sooner than on dry pavement.**
- **Allow greater following distances on slippery roads.**
- **Watch for slippery spots (glare ice). These may appear on an otherwise clear road in shaded areas. If a patch of ice is seen ahead, brake before**

**reaching it. Try not to brake while actually on the ice, and avoid any sudden steering maneuvers.**

- **Do not use cruise control on slippery roads.**
- **Snow can trap dangerous exhaust gases under your vehicle. Keep snow clear of the exhaust pipe and from around your vehicle.**

## ENGINE BLOCK HEATER (if so equipped)

An engine block heater to assist extreme cold temperature starting is available through your INFINITI dealer.



### WARNING

**Do not use your heater with an ungrounded electrical system or two-pronged (cheater) adapters. You can be injured by an electrical shock if you use an ungrounded connection.**

**MEMO**

# 6 In case of emergency

Roadside assistance program.....	6-2	Push starting .....	6-10
Flat tire .....	6-2	If your vehicle overheats.....	6-10
Low tire pressure warning system .....	6-2	Towing your vehicle .....	6-11
Changing a flat tire .....	6-2	Towing recommended by INFINITI .....	6-12
Jump starting.....	6-8	Vehicle recovery (Freeing a stuck vehicle).....	6-14



## ROADSIDE ASSISTANCE PROGRAM

Every new INFINITI comes with a 4 year, unlimited mileage Roadside Assistance plan. In the event of a roadside emergency, Roadside Assistance Service is available to you. Please refer to your Warranty Booklet (U.S.) or Warranty & Roadside assistance information booklet (Canada) for details. Both the Warranty Booklet and Roadside Assistance Calling Card in your Owner's Literature Portfolio provide the Toll-Free Number to call for assistance. Roadside Assistance is provided 24 hours a day, 365 days a year, for 4 years from the date sold to give emergency roadside help, in the event of mechanical or nonmechanical trouble(s) such as flat tires, out-of-gas, dead battery, lost keys, mechanical breakdown, accident, etc.

## FLAT TIRE

### LOW TIRE PRESSURE WARNING SYSTEM

The low tire pressure warning system monitors the pressure of all tires (except the spare tire) by sending a signal from a sensor that is installed in each wheel. If the vehicle is being driven with a very low tire pressure (lower than 25 psi: Sedan / 28 psi: Coupe), the low tire pressure warning system will activate and warn you of it by the low tire pressure warning light in the meter panel. This system will activate only when the vehicle is driven at speeds above 20 MPH (32 km/h). For more details, refer to "Warning/indicator lights and audible reminders" in the "2. Instruments and controls" section and "Low tire pressure warning system" in the "5. Starting and driving" section.



### WARNING

- If the low tire pressure warning light comes on while driving, avoid sudden steering maneuvers or abrupt braking, reduce vehicle speed, pull off the road to a safe location and stop the vehicle as soon as possible.

**Serious vehicle damage could occur and may lead to an accident and could result in serious personal injury. Check the pressure of all four tires. Adjust the tire pressure to the recommended COLD tire pressure shown on the Tire and Loading Information label to turn the low tire pressure warning light OFF. If you have a flat tire, replace it with a spare tire as soon as possible.**

- When a spare tire is mounted or a wheel is replaced, the tire pressure will not be indicated and the low tire pressure warning system will not function. Contact your INFINITI dealer as soon as possible for tire replacement and/or system resetting.
- Do not inject any tire liquid or aerosol tire sealant into the tires, as this may cause a malfunction of the tire pressure sensors.

## CHANGING A FLAT TIRE

If you have a flat tire, follow the instructions below.

## Stopping the vehicle

1. Safely move the vehicle off the road away from traffic.
2. Turn on the hazard warning flashers.
3. Park on a level surface and apply the parking brake. Shift the manual transmission into the R (Reverse) position (automatic transmission into the P (Park) position).
4. Turn off the engine.
5. Raise the hood to warn other traffic, and to signal professional road assistance personnel that you need assistance.
6. Have all passengers get out of the vehicle and stand in a safe place, away from traffic and clear of the vehicle.



### WARNING

- Make sure that the parking brake is securely applied and the manual transmission is shifted into R (Reverse), or the automatic transmission into P (Park).

- **Never change tires when the vehicle is on a slope, ice or slippery areas. This is hazardous.**
- **Never change tires if oncoming traffic is close to your vehicle. Wait for professional road assistance.**

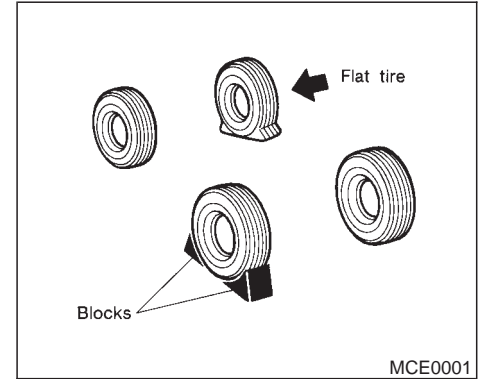

## Blocking wheels

Place suitable blocks at both the front and back of the wheel diagonally opposite the flat tire to prevent the vehicle from rolling when it is jacked up.



### WARNING

Be sure to block the wheel as the vehicle may move and could cause personal injury.

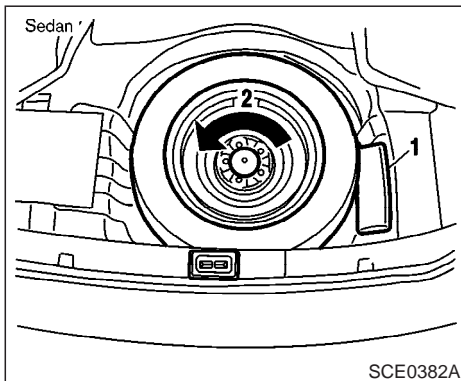

### Getting the spare tire and tools

Remove jacking tools 1 and spare tire 2 from the storage area located inside the trunk as illustrated.

If spacers are equipped, remove them before removing the spare tire.

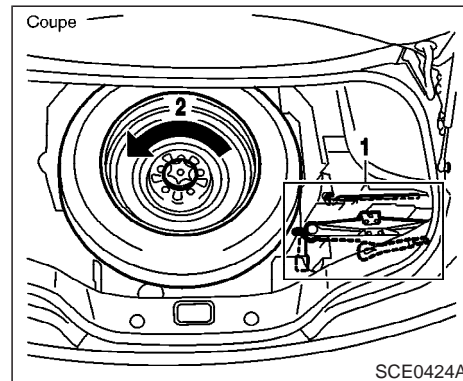
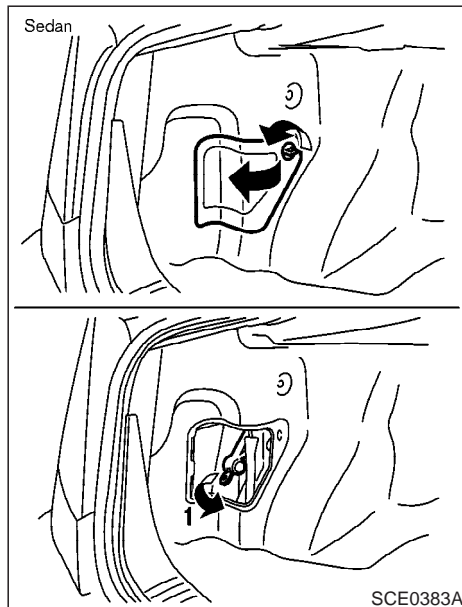

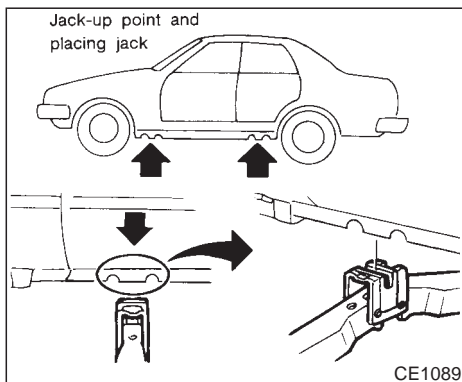

Jacking up vehicle and removing the damaged tire

**Carefully read the caution label attached to the jack body and the following instructions.**

1. Place the jack directly under the jack-up point as illustrated above so that top of the jack contacts the vehicle at the jack up point. Align the jack head between the two notches in the front or the rear as shown. Also fit the groove of the jack head between the notches as shown.

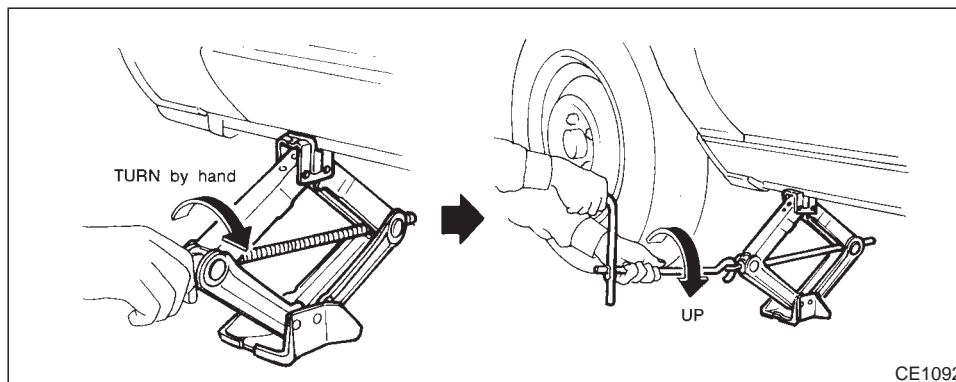

**The jack should be used on level firm ground.**

2. Loosen each wheel nut one or two turns by turning counterclockwise with the wheel nut wrench. **Do not remove the wheel nuts until the tire is off the ground.**
3. Carefully raise the vehicle until the tire clears the ground. To lift the vehicle, securely hold the jack lever and rod with both hands as shown above. Remove the wheel nuts, and then remove the tire.



## WARNING

- **Never get under the vehicle while it is supported only by the jack.**
- **Use only the jack provided with your vehicle to lift the vehicle. Do not use the jack provided with your vehicle on other vehicles.**  
The jack is designed only for lifting your vehicle during a tire change.

- Use the correct jack up points; never use any other part of the vehicle for jack support.
- Never jack up the vehicle more than necessary.
- Never use blocks on or under the jack.
- Do not start or run the engine while the vehicle is on the jack, as it may cause the vehicle to move. This is especially true for vehicles with limited slip differential.
- Do not allow passengers to stay in the vehicle while it is on the jack.

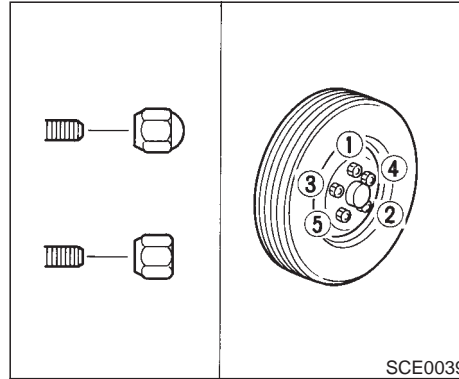

### Installing the spare tire

The spare tire is designed emergency use. See specific instructions under the heading “Wheels and tires” in the “8. Maintenance and do-it-yourself” section.

1. Clean any mud or dirt from the surface between the wheel and hub.
2. Carefully put the wheel on and tighten the wheel nuts finger tight.

(Coupe models)

When replacing a front tire, make sure the hole

in the spare tire wheel is aligned with the pin on the brake rotor.

3. With the wheel nut wrench, tighten wheel nuts alternately and evenly until they are tight.
4. Lower the vehicle slowly until the tire touches the ground. Then, with the wheel nut wrench, tighten the wheel nuts securely in the sequence illustrated (①, ②, ③, ④, ⑤). Lower the vehicle completely.



### WARNING

- Incorrect wheel nuts or improperly tightened wheel nuts can cause the wheel to become loose or come off. This could cause an accident.
- Do not use oil or grease on the wheel studs or nuts. This could cause the nuts to become loose.

**Retighten the wheel nuts when the vehicle has been driven for 600 miles (1,000 km) (also in cases of a flat tire, etc.). As soon as possible tighten the wheel nuts to the specified torque with a torque wrench.**



### Wheel nut tightening torque:

80 ft-lb (108 N-m)

The wheel nuts must be kept tightened to specification at all times. It is recommended that wheel nuts be tightened to specification at each lubrication interval.

Adjust the tire pressure to the COLD pressure.

#### COLD pressure:

After the vehicle has been parked for three hours or more or driven less than 1 mile (1.6 km) at moderate speeds.

COLD tire pressures are shown on the Tire and Loading Information label affixed to the driver side center pillar.

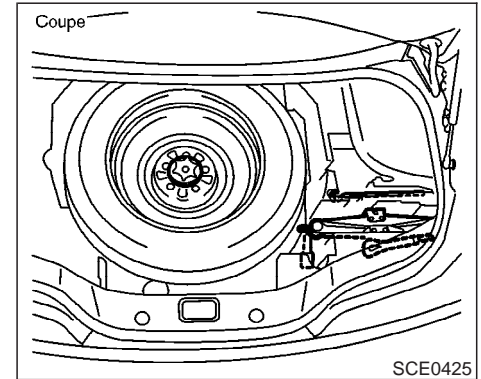
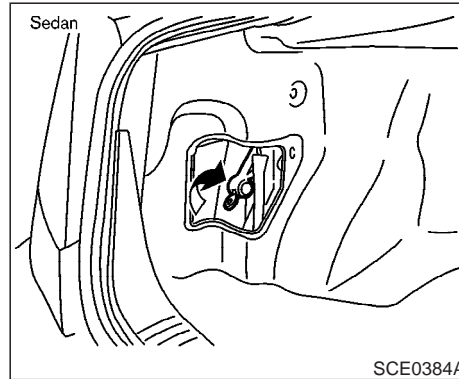

5. Securely store the flat tire and jacking equipment in the vehicle.
6. Place the spare tire cover and the trunk floor carpeting over the damaged tire.
7. Close the trunk.



### WARNING

- Always make sure that the spare tire and jacking equipment are properly secured after use. Such items can become dangerous projectiles in an

#### accident or sudden stop.

- The T-type spare tire and small size spare tire are designed for emergency use. See "Wheels and tires" in the "8. Maintenance and do-it-yourself" section.

If needed, Roadside Assistance is available. Please see your Warranty Information Booklet or Roadside Assistance I.D. Card for the toll-free number to call (U.S.) or Warranty Information Booklet (Canada).

## JUMP STARTING

To start your engine with a booster battery, the instructions and precautions below must be followed.



### WARNING

- If done incorrectly, jump starting can lead to a battery explosion, resulting in severe injury or death. It could also damage your vehicle.
- Explosive hydrogen gas is always present in the vicinity of the battery. Keep all sparks and flames away from the battery.
- Do not allow battery fluid to come into contact with eyes, skin, cloth or painted surfaces. Battery fluid is a corrosive sulphuric acid solution which can cause severe burns. If the fluid should come into contact with anything, immediately flush the contacted area with water.
- Keep battery out of the reach of children.

- The booster battery must be rated at 12 volts. Use of an improperly rated battery can damage your vehicle.
- Whenever working on or near a battery, always wear suitable eye protectors (for example, goggles or industrial safety spectacles) and remove rings, metal bands, or any other jewelry. Do not lean over the battery when jump starting.
- Do not attempt to jump start a frozen battery. It could explode and cause serious injury.

If needed Roadside Assistance is available. Please see your Warranty Information Booklet or Roadside Assistance I.D. Card for the toll-free number to call (U.S.) or Warranty Information Booklet (Canada).

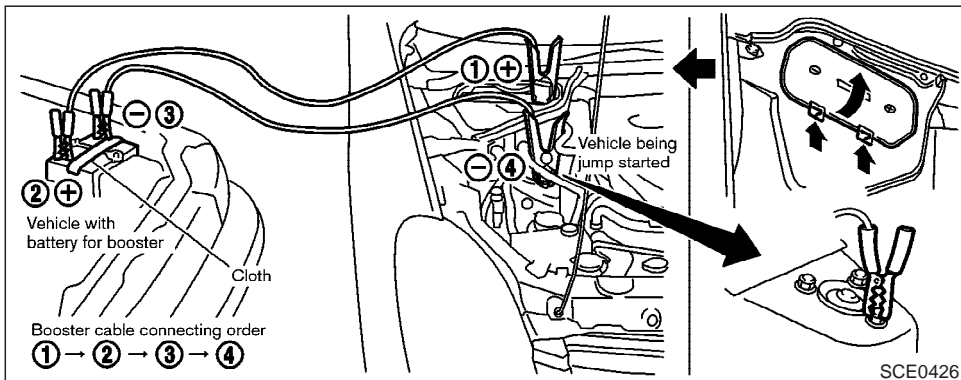

## WARNING

Always follow the instructions below. Failure to do so could result in damage to the charging system and cause personal injury.

1. If the booster battery is in another vehicle, position the two vehicles to bring their batteries into close proximity to each other.

**Do not allow the two vehicles to touch.**

2. Apply parking brake. Move the shift lever to the N (Neutral) position (On automatic transmission models, move the selector lever to the P (Park) position). Switch off all unnecessary electrical systems (light, heater, air conditioner, etc.).
3. Remove vent caps on the battery (if so equipped). Cover the battery with an old cloth to reduce explosion hazard.
4. Connect jumper cables in the sequence as illustrated.



## CAUTION

- Always connect positive (+) to positive (+) and negative (-) to body ground (for example, strut mounting bolt, etc. — not to the battery).
- Make sure that cables do not touch moving parts in the engine compartment and that clamps do not contact any other metal.

5. Start the engine of the other vehicle and let it run for a few minutes.
6. Keep the engine speed of the other vehicle at about 2,000 rpm, and start your engine in the normal manner.



## CAUTION

**Do not keep starter motor engaged for more than 10 seconds. If the engine does not start right away, turn the key off and wait 3 to 4 seconds before trying again.**

7. After starting your engine, carefully disconnect the negative cable and then the positive cable.
8. Replace the vent caps (if so equipped). Be sure to dispose of the cloth used to cover the vent holes as it may be contaminated with corrosive acid.

## PUSH STARTING

Do not attempt to start the engine by pushing.



### CAUTION

- **Automatic transmission models cannot be push started. Attempting to do so may cause transmission damage.**
- **Three way catalyst equipped models should not be started by pushing since the three way catalyst may be damaged.**
- **Never try to start the vehicle by towing it; when the engine starts, the forward surge could cause the vehicle to collide with the tow vehicle.**

If needed Roadside Assistance is available. Please see your Warranty Information Booklet or Roadside Assistance I.D. Card for the toll-free number to call (U.S.) or Warranty Information Booklet (Canada).

## IF YOUR VEHICLE OVERHEATS



### WARNING

- **Do not continue to drive if your vehicle overheats. Doing so could cause a vehicle fire.**
- **To avoid the danger of being scalded, never remove the radiator cap while the engine is still hot. When the radiator cap is removed, pressurized hot water will spurt out, possibly causing serious injury.**
- **Do not open the hood if steam is coming out.**

If your vehicle is overheating (indicated by an extremely high temperature gauge reading), or if you feel a lack of engine power, detect abnormal noise, etc., take the following steps:

1. Move the vehicle safely off the road, apply the parking brake and move the shift lever to the N (Neutral) position (automatic transmission to the P (Park) position).

**Do not stop the engine.**

2. Turn off the air conditioner switch. Open all the windows, move the heater or air condi-

tioner temperature control to maximum hot and fan control to high speed.

3. If engine overheating is caused by climbing a long hill on a hot day, run the engine at a fast idle (approximately 1,500 rpm) until the temperature gauge indication returns to normal.
4. Get out of the vehicle. Look and listen for steam or coolant escaping from the radiator before opening the hood. Wait until no steam or coolant can be seen before proceeding.
5. Open the engine hood.



## WARNING

**If steam or water is coming from the engine, stand clear to prevent getting burned.**

6. Visually check if the cooling fan is running. The radiator hoses and radiator should not leak water.

If coolant is leaking or the cooling fan does not run, stop the engine.



## WARNING

- **Be careful not to allow your hands, hair, jewelry or clothing to come into contact with, or to get caught in the cooling fan, or drive belt.**
- **The engine cooling fan can start at any time when the coolant temperature is high.**

7. After the engine cools down, check the coolant level in the reservoir tank with the engine running. Add coolant to the reservoir tank if necessary. Have your vehicle repaired at the nearest INFINITI dealer.

If needed, Roadside Assistance is available. Please see your Warranty Information Booklet or Roadside Assistance I.D. Card for the toll-free number to call (U.S.) or Warranty Information Booklet (Canada).

## TOWING YOUR VEHICLE

When towing your vehicle, all State (Provincial in Canada) and local regulations for towing must be followed. Incorrect towing equipment could damage your vehicle. Towing instructions are available from an authorized INFINITI dealer. Local service operators are generally familiar with the applicable laws and procedures for towing. To assure proper towing and to prevent accidental damage to your vehicle, INFINITI recommends having a service operator tow your vehicle. It is advisable to have the service operator carefully read the following precautions.



## WARNING

- **Never ride in a vehicle that is being towed.**
- **Never get under your vehicle after it has been lifted by a tow truck.**



## CAUTION

- **When towing, make sure that the transmission, axles, steering system and powertrain are in working condi-**

**tion. If any unit is damaged, dollies must be used.**

- **Always attach safety chains before towing.**

For information about towing your vehicle behind a recreational vehicle (RV), refer to “Flat towing” in the “9. Technical and consumer information” section of this manual.

If needed, Roadside Assistance is available. Please see your Warranty Information Booklet or Roadside Assistance I.D. Card for the toll-free number to call (U.S.) or Warranty Information Booklet (Canada).

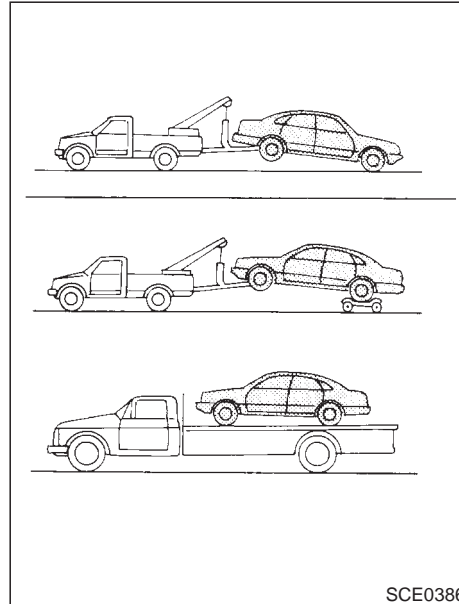

ground or place the vehicle on a flat bed truck as illustrated.

## TOWING RECOMMENDED BY INFINITI

### Two wheel drive models

INFINITI recommends that your vehicle be towed with the driving (rear) wheels off the

Automatic transmission model

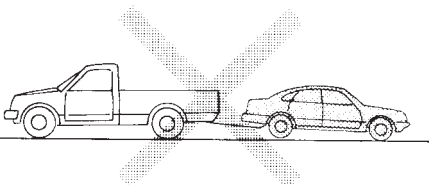
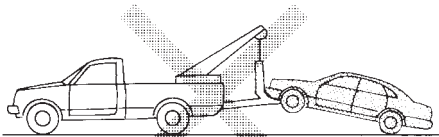

SCE0387



## CAUTION

- Never tow automatic transmission models with the rear wheels on the

ground or four wheels on the ground (forward or backward) as this may cause serious and expensive damage to the transmission.

If it is necessary to tow the vehicle with the front wheels raised, always use towing dollies under the rear wheels.

- When towing rear wheel drive models with the front wheels on the ground or on towing dollies:

Turn the ignition key to the OFF position, and secure the steering wheel in a straight ahead position with a rope or similar device. Never secure the steering wheel by turning the ignition key to the LOCK position. This may damage the steering lock mechanism.

- If you have to tow manual transmission models with the rear wheels on the ground or four wheels on the ground (if you do not use towing dollies):

- Always release the parking brake.
- Move the transmission shift lever to the N (Neutral) position.
- Observe the following restricted towing speeds and distances for manual transmission models only:
  - Speed: Below 60 MPH (95 km/h)
  - Distance: Less than 500 miles (800 km)

If the speed or distance must necessarily be greater, remove the propeller shaft before towing to prevent damage to the transmission.

## All wheel drive models

INFINITI recommends that towing dollies be used when towing your vehicle, or the vehicle be placed on a flat bed truck as illustrated.



## CAUTION

Never tow AWD models with any of the wheels on the ground as this may cause serious and expensive damage to the power train.

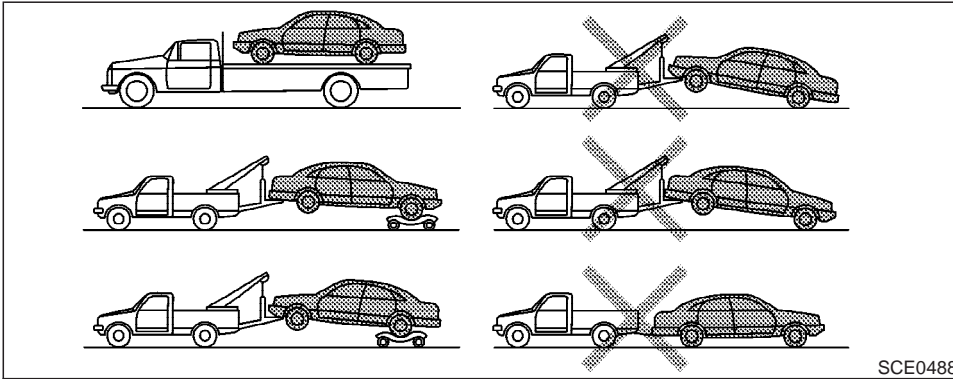

SCE0488

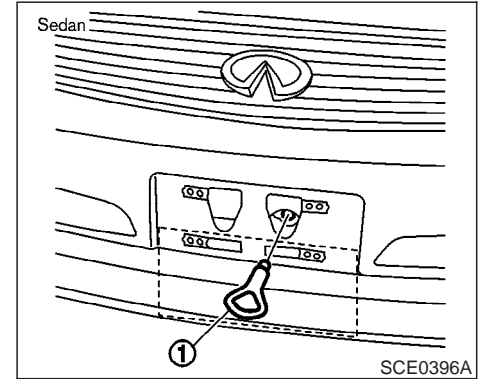

SCE0396A

## VEHICLE RECOVERY (Freeing a stuck vehicle)

After removing the front license plate (or the bumper cover), securely install the towing hook ①. (Located with jacking tools.)

Reinstall the license plate on the lower fitting point.



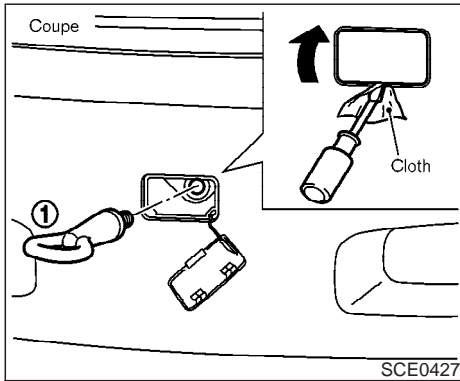

## WARNING

- Stand clear of a stuck vehicle.
- Do not spin your tires at high speed. This could cause them to explode and result in serious injury. Parts of your vehicle could also overheat and be damaged.

## CAUTION

- Tow chains or cables must be attached only to the main structural members of the vehicle.
- Use the towing hook only, not other parts of the vehicle. Otherwise, the vehicle body will be damaged.
- Use the towing hook only to free a vehicle stuck in sand, snow, mud, etc. Never tow a vehicle for a long distance using only the tow hook.
- The towing hook is under tremendous force when used to free a stuck vehicle. Always pull the cable straight out from the front of the vehicle. Never pull on the vehicle at an angle.
- Pulling devices should be routed so they do not touch any part of the suspension, steering, brake or cooling systems.

- Pulling devices such as ropes or canvas straps are not recommended for use in vehicle towing or recovery.

**MEMO**

# 7 Appearance and care

Cleaning exterior .....	7-2	Floor mats .....	7-4
Washing.....	7-2	Seat belts .....	7-4
Waxing.....	7-2	Corrosion protection.....	7-5
Removing spots.....	7-3	Most common factors contributing to vehicle	
Underbody .....	7-3	corrosion.....	7-5
Glass .....	7-3	Environmental factors influence the rate of	
Aluminum alloy wheels.....	7-3	corrosion.....	7-5
Chrome parts.....	7-3	To protect your vehicle from corrosion .....	7-5
Cleaning interior .....	7-3		

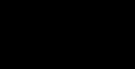

## CLEANING EXTERIOR

In order to maintain the appearance of your vehicle, it is important to care for it properly.

To protect the paint surfaces, please wash your vehicle as soon as you can.

- After a rainfall to prevent possible damage from acid rain.
- After driving in coastal areas to prevent possible damage from sea salt.
- When foreign objects, such as soot, bird droppings, tree sap, metal particles, or insects get on the paint surfaces.
- When dust or mud builds up on the paint surfaces.

Whenever possible, store or park your vehicle inside garage or in covered area.

When it is necessary to park outside, park in a shady area or protect the vehicle with a body cover.

**Be careful not to scratch the paint surface when putting on or removing the body cover.**

## WASHING

Thoroughly rinse surface dirt off the vehicle with a wet sponge and plenty of clean water. Clean the vehicle thoroughly using a mild soap such as Nissan Car Wash, or a general pur-

pose dishwashing liquid mixed with clean, lukewarm (never hot) water.



### CAUTION

- **Do not use strong household soap, strong chemical detergents, gasoline or solvents.**
- **Do not wash the vehicle in direct sunlight or while the vehicle body is hot, as the surface may become water-spotted.**
- **Avoid using tight-napped or rough cloths, such as washing mitts. Care must be taken when removing caked-on dirt or other foreign substances so that the paint surface is not scratched or damaged.**

Rinse the vehicle again with plenty of clean water.

Inside flanges, seams and folds on the doors, hatches and hood are particularly vulnerable to the effects of road salt. Therefore, these areas must be regularly cleaned. Make sure that the drain holes in the lower edge of the door are open. Spray water under the body

and in the wheel wells to loosen the dirt and wash away road salt.

Avoid leaving water spots on the paint surface by using a damp chamois to dry the vehicle.

## WAXING

Regular waxing protects the paint surface and helps retain new vehicle appearance. Polishing is recommended to remove built-up wax residue and to avoid a weathered appearance before re-applying wax.

If you wish to wax your vehicle, only use a wax specified for use over clear coats, such as Nissan Liquid or Spray Wax. Your INFINITI dealer can assist you in choosing the proper product.

- Wax your vehicle only after a thorough washing. Follow the instructions supplied with the wax.
- Do not use a wax containing any abrasives, cutting compounds or cleaners that may damage the vehicle finish.
- If the surface does not polish easily, use a road tar remover and wax again.

**Machine compounding or aggressive polishing on a base coat/clear coat paint finish may dull the finish or leave swirl marks.**

## REMOVING SPOTS

Remove tar and oil spots, industrial dust, insects, and tree sap as quickly as possible from the surface of the paint to avoid lasting damage or staining. Special cleaning products are available at your INFINITI dealer or any automotive accessory store.

## UNDERBODY

In areas where road salt is used in winter, the underbody must be cleaned regularly. This will prevent dirt and salt from building up and causing underbody and suspension corrosion. Before the winter period and again in the spring, the underseal must be checked and, if necessary, re-treated.

## GLASS

Use glass cleaner to remove smoke and dust film from the glass surfaces. It is normal for glass to become coated with a film after the vehicle is parked in the hot sun. Glass cleaner and a soft cloth will easily remove this film.



### CAUTION

**When cleaning the inside of the window, do not use sharp-edged tools, abrasive**

**cleaners or chlorine based disinfectant cleaners. They could damage the electrical conductors, radio antenna elements or rear window defogger elements.**

## ALUMINUM ALLOY WHEELS

Wash regularly, especially during winter months in areas where road salt is used. Salt could discolor the wheel if not removed.

## CHROME PARTS

Clean all chrome parts regularly with a non-abrasive chrome polish to maintain the finish.

## CLEANING INTERIOR

Occasionally remove loose dust from the interior trim, plastic parts and seats using a vacuum cleaner or soft brush. Wipe the vinyl and leather surfaces with a clean, soft cloth dampened in mild soap solution, then wipe clean with a dry soft cloth. Before using any fabric protector, read the manufacturer's recommendations. Some fabric protectors contain chemicals that may stain or bleach the seat material.

Use a cloth dampened only with water, to clean the meter and gauge lens.



### CAUTION

- **Never use gasoline, thinner, or any similar material.**
- **The leather seats should be regularly coated with a leather wax like saddle soap. Never use car wax.**
- **Never use fabric protectors unless recommended by the manufacturer.**
- **Do not use glass or plastic cleaner on meter or gauge lens covers. It may damage the lens cover.**

## FLOOR MATS

The use of Genuine INFINITI floor mats can extend the life of your vehicle carpet and make it easier to clean the interior. **No matter what mats are used, be sure they are fitted for your vehicle and are properly positioned in the footwell to prevent interference with pedal operation.** Mats should be maintained with regular cleaning and replaced if they become excessively worn.

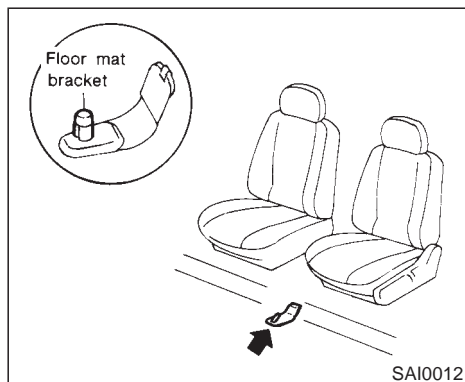

### Floor mat positioning aid (Driver side only)

This model includes a front floor mat bracket to act as a floor mat positioning aid. INFINITI floor mats have been specially designed for your vehicle model. The driver's side floor mat has a grommet hole incorporated in it. Simply position the mat by placing the floor mat bracket through the floor mat grommet hole while centering the mat in the floorpan contour.

Periodically check to make certain that the mats are properly positioned.

## SEAT BELTS

The seat belts can be cleaned by wiping them with a sponge dampened in a mild soap solution. Allow the belts to dry completely before using them.



### WARNING

**Do not allow wet belts to roll up in the retractor. NEVER use bleach, dye, or chemical solvents since these may severely weaken the seat belt webbing.**

## CORROSION PROTECTION

### MOST COMMON FACTORS CONTRIBUTING TO VEHICLE CORROSION:

- The accumulation of moisture-retaining dirt and debris in body panel sections, cavities, and other areas.
- Damage to paint and other protective coatings caused by gravel and stone chips or minor traffic accidents.

### ENVIRONMENTAL FACTORS INFLUENCE THE RATE OF CORROSION:

#### Moisture

Accumulation of sand, dirt and water on the vehicle body underside can accelerate corrosion. Wet floor coverings will not dry completely inside the vehicle, and should be removed for drying to avoid floor panel corrosion.

#### Relative humidity

Corrosion will be accelerated in areas of high relative humidity, especially those areas where the temperatures stay above freezing and where atmospheric pollution exists and road salt is used.

#### Temperature

A temperature increase will accelerate the rate of corrosion to those parts which are not well ventilated.

#### Air pollution

Industrial pollution, the presence of salt in the air in coastal areas, or heavy road salt use will accelerate the corrosion process. Road salt will also accelerate the disintegration of paint surfaces.

### TO PROTECT YOUR VEHICLE FROM CORROSION:

- Wash and wax your vehicle often to keep it clean.
- Always check for minor damage to the paint and repair it as soon as possible.
- Keep drain holes at the bottom of the doors open to avoid water accumulation.
- Check the underbody for accumulation of sand, dirt or salt. If present, wash with water as soon as possible.



## CAUTION

- **NEVER** remove dirt, sand or other debris from the passenger compartment by washing it out with a hose. Remove dirt with a vacuum cleaner or broom.
- **Never** allow water or other liquids to come in contact with electronic components inside the vehicle as this may damage them.

Chemicals used for road surface de-icing are extremely corrosive. They accelerate corrosion and deterioration of underbody components such as the exhaust system, fuel and brake lines, brake cables, floor pan and fenders.

**In winter, the underbody must be cleaned periodically.**

For additional protection against rust and corrosion, which may be required in some areas, consult your local INFINITI dealer.

**MEMO**



# 8 Maintenance and do-it-yourself

Maintenance requirements.....	8-2	Air cleaner .....	8-19
General maintenance.....	8-2	Windshield wiper blades .....	8-19
Explanation of maintenance items .....	8-3	Cleaning .....	8-19
Maintenance precautions .....	8-5	Replacing.....	8-20
Engine compartment check locations .....	8-7	Parking brake and brake pedal.....	8-21
Engine cooling system .....	8-8	Checking parking brake .....	8-21
Checking engine coolant level .....	8-8	Checking brake pedal .....	8-22
Changing engine coolant .....	8-9	Brake booster .....	8-22
Engine oil .....	8-10	Fuses.....	8-23
Checking engine oil level .....	8-10	Engine compartment .....	8-23
Changing engine oil and filter .....	8-11	Passenger compartment .....	8-24
Automatic transmission fluid .....	8-13	Keyfob battery replacement.....	8-25
Power steering fluid .....	8-13	Lights.....	8-26
Brake and clutch fluid .....	8-14	Headlights.....	8-28
Brake fluid .....	8-14	Exterior and interior lights .....	8-29
Clutch fluid .....	8-14	Wheels and tires .....	8-33
Window washer fluid.....	8-15	Tire pressure .....	8-33
Battery .....	8-16	Tire labeling.....	8-35
Jump starting.....	8-17	Types of tires.....	8-37
Drive belts .....	8-18	Tire chains.....	8-38
Spark plugs .....	8-18	Changing wheels and tires.....	8-39
Replacing spark plugs.....	8-19		

## MAINTENANCE REQUIREMENTS

Your new INFINITI has been designed to have minimum maintenance requirements with longer service intervals to save you both time and money. However, some day-to-day and regular maintenance is essential to maintain your INFINITI's good mechanical condition, as well as its emission and engine performance.

It is the owner's responsibility to make sure that the specified maintenance and the general maintenance are performed.

As the vehicle owner, you are the only one who can ensure that your vehicle receives the proper maintenance care. You are a vital link in the maintenance chain.

### **Scheduled maintenance:**

For your convenience, both required and optional scheduled maintenance items are described and listed in your "INFINITI Service and Maintenance Guide". You must refer to that guide to ensure that necessary maintenance is performed on your INFINITI at regular intervals.

### **General maintenance:**

General maintenance includes those items which should be checked during normal day-to-day operation. They are essential for proper vehicle operation. It is your responsibility to

perform these maintenance procedures regularly as prescribed.

Performing general maintenance checks requires minimal mechanical skill and only a few general automotive tools.

These checks or inspections can be done by you, a qualified technician, or, if you prefer, an INFINITI dealer.

### **Where to go for service:**

If maintenance service is required or your vehicle appears to malfunction, have the systems checked and serviced by an authorized INFINITI dealer.

INFINITI technicians are well-trained specialists and are kept up to date with the latest service information through technical bulletins, service tips, and in-dealership information systems. They are completely qualified to work on INFINITI vehicles **before** work begins.

You can be confident that your INFINITI dealer's service department performs the best job to meet the maintenance requirements on your vehicle — in a reliable and economic way.

## GENERAL MAINTENANCE

During the normal day-to-day operation of the vehicle, general maintenance should be performed regularly as prescribed in this section. If you detect any unusual sounds, vibrations or smell, be sure to check for the cause or have your INFINITI dealer perform it promptly. In addition, you should notify your INFINITI dealer if you think the repairs are required.

When performing any checks or maintenance work, closely observe the "Maintenance precautions" later in this section.

## EXPLANATION OF MAINTENANCE ITEMS

**Additional information on the following items with “\*” is found later in this section.**

### Outside the vehicle

The maintenance items listed here should be performed from time to time, unless otherwise specified.

**Doors and engine hood:** Check that all doors and the engine hood operate properly. Also ensure that all latches lock securely. Lubricate hinges and latches if necessary. Make sure that the secondary latch keeps the hood from opening when the primary latch is released.

When driving in areas using road salt or other corrosive materials, check lubrication frequently.

**Lights\*:** Clean the headlights on a regular basis. Make sure that the headlights, stop lights, tail lights, turn signal lights, and other lights are all operating properly and installed securely. Also check headlight aim.

**Road wheel nuts (lug nuts):** When checking the tires, make sure no wheel nuts are missing, and check for any loose wheel nuts. Tighten if necessary.

**Tires\*:** Check the pressure with a gauge often and always prior to long distance trips. If necessary, adjust the pressure in all tires, including the spare, to the specified pressure. Check carefully for damage, cuts or excessive wear.

### **Tire rotation\*:**

Sedan: The tires should be rotated every 7,500 miles (12,000 km) to minimize tire wear variation.

Coupe: The tires cannot be rotated.

**Tire, wheel alignment and balance:** If the vehicle should pull to either side while driving on a straight and level road, or if you detect uneven or abnormal tire wear, there may be a need for wheel alignment.

If the steering wheel or seat vibrates at normal highway speeds, wheel balancing may be needed.

- For additional information regarding tires, refer to “Important Tire Safety Information” (US) or “Tire Safety Information” (Canada) in the Warranty Information Booklet.

**Windshield:** Clean the windshield on a regular basis. Check the windshield at least every six months for cracks or other damage. Have a damaged windshield repaired by a qualified repair facility.

**Windshield wiper blades\*:** Check for cracks or wear if they do not wipe properly.

## Inside the vehicle

The maintenance items listed here should be checked on a regular basis, such as when performing periodic maintenance, cleaning the vehicle, etc.

**Accelerator pedal:** Check the pedal for smooth operation and make sure the pedal does not catch or require uneven effort. Keep the floor mat away from the pedal.

**Automatic transmission P (Park) mechanism:** On a fairly steep hill check that your vehicle is held securely with the selector lever in the P (Park) position without applying any brakes.

**Brake pedal\*:** Check the pedal for smooth operation and make sure it has the proper distance under it when depressed fully. Check the brake booster function. Be sure to keep the floor mat away from the pedal.

**Brakes:** Check that the brakes do not pull the vehicle to one side when applied.

**Clutch pedal\*:** Make sure the pedal operates smoothly and check that it has the proper free play.

**Parking brake\*:** Check that the lever has the proper travel and confirm that your vehicle is

held securely on a fairly steep hill with only the parking brake applied.

**Seats:** Check seat position controls such as seat adjusters, seatback recliner, etc. to ensure they operate smoothly and that all latches lock securely in every position. Check that the head restraints move up and down smoothly and that the locks (if so equipped) hold securely in all latched positions.

**Seat belts:** Check that all parts of the seat belt system (For example, buckles, anchors, adjusters and retractors) operate properly and smoothly, and are installed securely. Check the belt webbing for cuts, fraying, wear or damage.

**Steering wheel:** Check for changes in the steering conditions, such as excessive free play, hard steering or strange noises.

**Warning lights and chimes:** Make sure that all warning lights and chimes are operating properly.

**Windshield defroster:** Check that the air comes out of the defroster outlets properly and in sufficient quantity when operating the heater or air conditioner.

**Windshield wiper and washer\*:** Check that the wipers and washer operate properly and that the wipers do not streak.

## Under the hood and vehicle

The maintenance items listed here should be checked periodically (For example, each time you check the engine oil or refuel).

**Battery\*:** Check the fluid level in each cell. It should be between the MAX and MIN lines. Vehicles operated in high temperatures or under severe conditions require frequent checks of the battery fluid level.

**Brake and clutch fluid level\*:** Make sure that the brake and clutch fluid levels are between the MAX and MIN lines on the reservoir.

**Engine coolant level\*:** Check the coolant level when the engine is cold.

**Engine drive belts\*:** Make sure that no belt is frayed, worn, cracked or oily.

**Engine oil level\*:** Check the level after parking the vehicle on a level location and turning off the engine. (Wait at least 10 minutes for the oil to drain back into the oil pan.)

**Exhaust system:** Make sure there are no loose supports, cracks or holes. If the sound of the exhaust seems unusual or there is a smell of exhaust fumes, immediately locate the trouble and correct it. See “Precautions when starting and driving” in the “5. Starting and

driving” section for exhaust gas (Carbon monoxide).

**Fluid leaks:** Check under the vehicle for fuel, oil, water or other fluid leaks after the vehicle has been parked for a while. Water dripping from the air conditioner after use is normal. If you should notice any leaks or if gasoline fumes are evident, check for the cause and have it corrected immediately.

**Power steering fluid level\* and lines:** Check the level when the fluid is cold and the engine is turned off. Check the lines for proper attachment, leaks, cracks, etc.

**Radiator and hoses:** Check the front of the radiator and clean off any dirt, insects, leaves, etc., that may have accumulated. Make sure the hoses have no cracks, deformation, deterioration or loose connections.

**Underbody:** The underbody is frequently exposed to corrosive substances such as those used on icy roads or to control dust. It is very important to remove these substances, otherwise rust will form on the floor pan, frame, fuel lines and around the exhaust system. At the end of winter, the underbody should be thoroughly flushed with plain water, being careful to clean those areas where mud and dirt may accumulate. For additional information, see

“Cleaning exterior” in the “7. Appearance and care” section.

**Windshield washer fluid\*:** Check that there is adequate fluid in the tank.

## MAINTENANCE PRECAUTIONS

When performing any inspection or maintenance work on your vehicle, always take care to prevent serious accidental injury to yourself or damage to the vehicle. The following are general precautions which should be closely observed.



### WARNING

- **Park the vehicle on a level surface, apply the parking brake securely and block the wheels to prevent the vehicle from moving. For a manual transmission, move the shift lever to N (Neutral) position. For an automatic transmission, move the selector lever to P (Park) position.**
- **Be sure the ignition key is in the OFF or LOCK operation when performing any parts replacement or repairs.**
- **If you must work with the engine running, keep your hands, clothing, hair and tools away from moving fans, belts and any other moving parts.**
- **It is advised to secure or remove any**

loose clothing and any jewelry, such as rings, watches, etc. before working on your vehicle.

- Always wear eye protection whenever you work on your vehicle.
- If you must run the engine in an enclosed space such as a garage, be sure there is proper ventilation for exhaust gases to escape.
- Never get under the vehicle while it is supported only by a jack. If it is necessary to work under the vehicle, support it with safety stands.
- Keep smoking materials, flame and sparks away from fuel and the battery.
- On gasoline engine models with the Multiport Fuel Injection (MFI) System, the fuel filter or fuel lines should be serviced by an INFINITI dealer because the fuel lines are under high pressure even when the engine is off.



## CAUTION

- Do not work under the hood while the engine is hot. Turn off the engine and wait until it cools down.
- Never connect or disconnect either the battery or any transistorized component connector while the ignition key is on.
- Never leave any engine or automatic transmission related component harness connector disconnected while the ignition key is on.
- Avoid direct contact with used engine oil and coolant. Improperly disposed engine oil, engine coolant and/or other vehicle fluids can hurt the environment. Always conform to local regulations for disposal of vehicle fluid.

This “8. Maintenance and do-it-yourself” section gives instructions regarding only those items which are relatively easy for an owner to perform.

A genuine INFINITI Service Manual is also available. See “Owner’s Manual/Service Manual order information” in the “9. Technical and consumer information” section.

You should be aware that incomplete or improper servicing may result in operating difficulties or excessive emissions, and could affect your warranty coverage. **If in doubt about any servicing, have it done by your INFINITI dealer.**

## ENGINE COMPARTMENT CHECK LOCATIONS

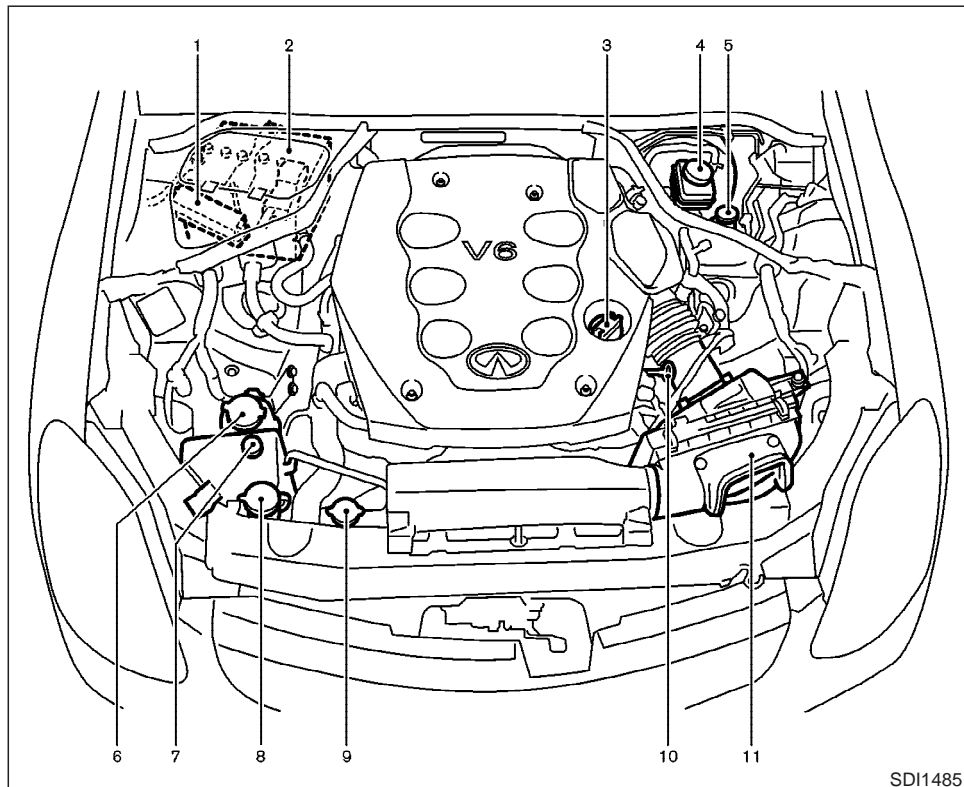

1. Fuse/fusible link holder
2. Battery
3. Engine oil filler cap
4. Brake fluid reservoir
5. Clutch fluid reservoir
6. Power steering fluid reservoir
7. Engine coolant reservoir
8. Windshield washer fluid reservoir
9. Radiator filler cap
10. Engine oil dipstick
11. Air cleaner

SD11485

## ENGINE COOLING SYSTEM

The engine cooling system is filled at the factory with a high-quality, year-round, anti-freeze coolant solution. The antifreeze solution contains rust and corrosion inhibitors, therefore additional cooling system additives are not necessary.

### CAUTION

When adding or replacing coolant, be sure to use only a Genuine Nissan Long Life Antifreeze/Coolant or equivalent with the proper mixture ratio of 50% antifreeze and 50% demineralized water/distilled water. The use of other types of coolant solutions may damage your engine cooling system.

Outside temperature down to		Antifreeze	Demineralized water/ distilled water
°C	°F		
-35	-30	50%	50%

### WARNING

- Never remove the radiator cap when the engine is hot. Serious burns could be caused by high pressure fluid escaping from the radiator. Wait until the engine and radiator cool down.
- See “If your vehicle overheats” in the “6. In case of emergency” section.
- The radiator is equipped with a pressure cap. To prevent engine damage, use only a genuine NISSAN radiator cap.

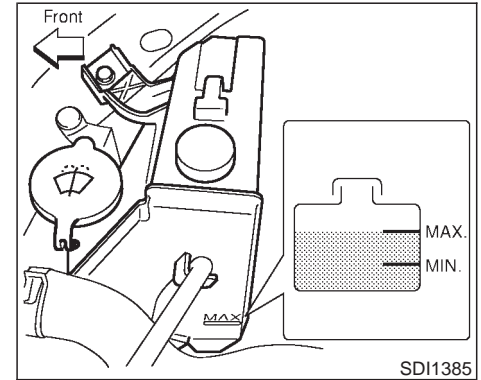

### CHECKING ENGINE COOLANT LEVEL

Check the coolant level in the reservoir tank when the engine is cold. If the coolant level is below MIN, add coolant up to the MAX level. If the reservoir tank is empty, check the coolant level in the radiator **when the engine is cold**. If there is insufficient coolant in the radiator, fill the radiator with coolant up to the filler opening and also add it to the reservoir tank up to the MAX level.

**If the engine cooling system frequently requires coolant, have it checked by your INFINITI dealer.**



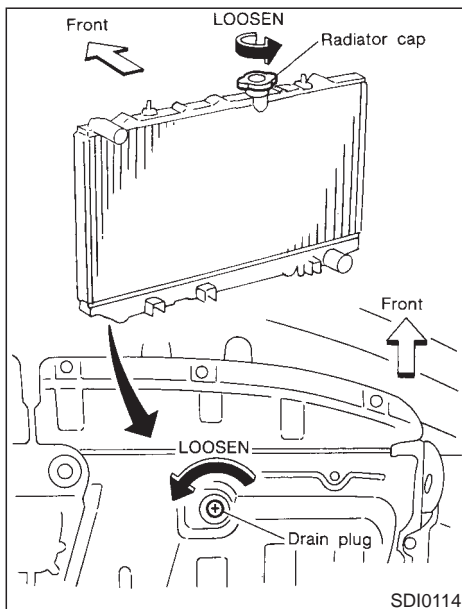

## CHANGING ENGINE COOLANT

- Major cooling system repairs should be performed by your INFINITI dealer. The service procedures can be found in the appropriate INFINITI Service Manual.

- Improper servicing can result in reduced heater performance and engine overheating.



## WARNING

- **To avoid being scalded, never change the coolant when the engine is hot.**
  - **Never remove the radiator cap when the engine is hot. Serious burns could be caused by high pressure fluid escaping from the radiator.**
  - **Avoid direct skin contact with used coolant. If skin contact is made, wash thoroughly with soap or hand cleaner as soon as possible.**
  - **Keep coolant out of reach of children and pets.**
1. Open radiator drain plug at the bottom of radiator, and remove radiator filler cap.

3. Fill the radiator slowly with the proper mixture of antifreeze solution and demineralized water/distilled water. Fill the reservoir tank up to the MAX level. Then install the radiator filler cap.

4. Start the engine and warm it up until it reaches normal operating temperature. Then race the engine 2 or 3 times under no load. Watch the engine coolant temperature gauge for signs of overheating.

5. Stop the engine. After it completely cools down, refill the radiator up to the filler opening. Fill the reservoir tank up to the MAX level. Check the drain plug for any sign of leakage.

6. Recheck the coolant level after the vehicle has been driven for a day.

## ENGINE OIL

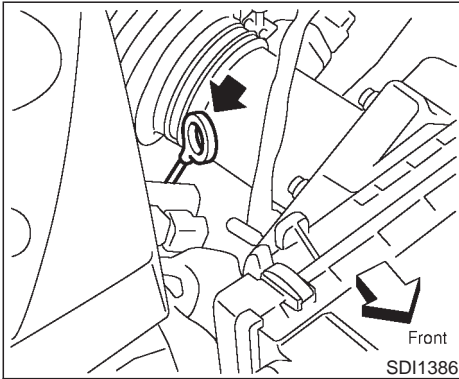

### CHECKING ENGINE OIL LEVEL

1. Park the vehicle on a level surface and apply the parking brake.
2. Run the engine until it reaches operating temperature.
3. Turn off the engine. **Wait more than 10 minutes for the oil to drain back into the oil pan.**
4. Remove the dipstick and wipe it clean. Reinsert it all the way.

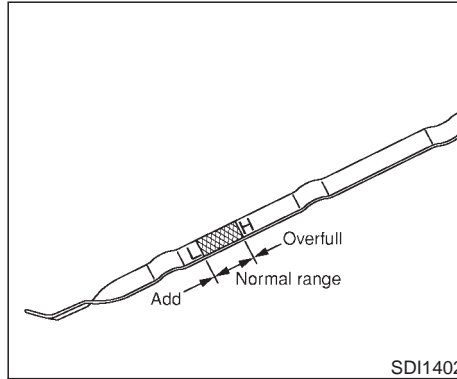

5. Remove the dipstick again and check the oil level. It should be between the H and L marks. If the oil level is below the L mark, remove the oil filler cap and pour recommended oil through the opening. **Do not overfill.**
6. Recheck oil level with dipstick.

**It is normal to add some oil between oil maintenance intervals or during the break-in period, depending on the severity of operating conditions.**



### CAUTION

Oil level should be checked regularly. Operating with insufficient amount of oil can damage the engine, and such damage is not covered by warranty.

## CHANGING ENGINE OIL AND FILTER

Change the engine oil and filter according to the maintenance intervals shown in the INFINITI Service and Maintenance Guide.

### Vehicle set-up

1. Park the vehicle on a level surface and apply the parking brake.
2. Run the engine until it reaches operating temperature.
3. Turn the engine off and wait more than 10 minutes.
4. Raise and support the vehicle using a suitable floor jack and safety jack stands.
  - Place the safety jack stands under the vehicle jack-up points.
  - A suitable adapter should be attached to the jack stand saddle.
5. Remove the plastic engine undercover.
  - a. Remove the small plastic clip at the center point of the undercover.
  - b. Then remove the other bolts that hold the undercover in place.



### CAUTION

**Make sure the correct lifting and support points are used to avoid vehicle damage.**

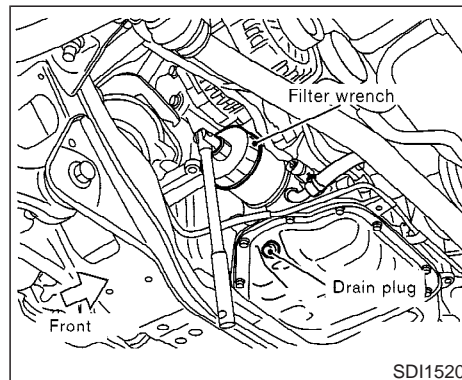

### Engine oil and filter

1. Place a large drain pan under the drain plug.
2. Remove the oil filler cap.
3. Remove the drain plug with a wrench and completely drain the oil.



### CAUTION

**Be careful not to burn yourself, as the engine oil is hot.**

- **Waste oil must be disposed of properly.**

- **Check your local regulations.**

4. Loosen the oil filter with an oil filter wrench. Remove the oil filter by turning it by hand.
5. Wipe the engine oil filter mounting surface with a clean rag.

**Be sure to remove any old rubber gasket remaining on the mounting surface of the engine.**

6. Coat the gasket on the new filter with clean engine oil.
7. Screw in the oil filter clockwise until a slight resistance is felt, then tighten additionally more than 2/3 turn.

**Oil filter tightening torque:**

**11 to 15 ft-lb  
(14.7 to 20.5 N·m)**

8. Clean and re-install the drain plug with a new washer. Securely tighten the drain plug with a wrench.

**Drain plug tightening torque:**

**22 to 29 ft-lb  
(29 to 39 N·m)**

Do not use excessive force.

9. Refill engine with recommended oil and install the cap securely.



## CAUTION

**The dipstick must be inserted in place to prevent oil spillage from the dipstick hole while filling the engine with oil.**

See “Capacities and recommended fuel/lubricants” in the “9. Technical and consumer information” section for drain and refill capacity. The drain and refill capacity depends on the oil temperature and drain time. Use these specifications for reference only. Always use the dipstick to determine the proper amount of oil in the engine.



## CAUTION

**When filling oil, do not pull out the dipstick.**

10. Start the engine and check for leakage around the drain plug and the oil filter. Correct as required.
11. Turn the engine off and wait more than 10 minutes. Check the oil level with the dipstick. Add engine oil if necessary.

## After the operation

1. Install the engine undercover into position as the following steps.
  - a. Pull the center of the small plastic clip out.
  - b. Hold the engine undercover into position.
  - c. Insert the clip through the undercover into the hole in the frame, then push the center of the clip in to lock the clip in place.
  - d. Install the other bolts that hold the undercover in place. Be careful not to strip the bolts or over-tighten them.
2. Lower the vehicle carefully to the ground.
3. Dispose of waste oil and filter properly.



## WARNING

- **Prolonged and repeated contact with used engine oil may cause skin cancer.**
- **Try to avoid direct skin contact with used oil. If skin contact is made, wash thoroughly with soap or hand cleaner as soon as possible.**

- **Keep used engine oil out of reach of children.**

## **AUTOMATIC TRANSMISSION FLUID**

If checking or replacement is required, we recommend your INFINITI dealer for servicing.



### **CAUTION**

- **Use only Genuine Nissan Matic J ATF. Do not mix with other fluids.**
- **Using automatic transmission fluid other than Genuine Nissan Matic J ATF will cause deterioration in drivability and automatic transmission durability, and may damage the automatic transmission, which is not covered by the INFINITI new vehicle limited warranty.**

The specified automatic transmission fluid is also described on caution labels located in the engine compartment.

## **POWER STEERING FLUID**

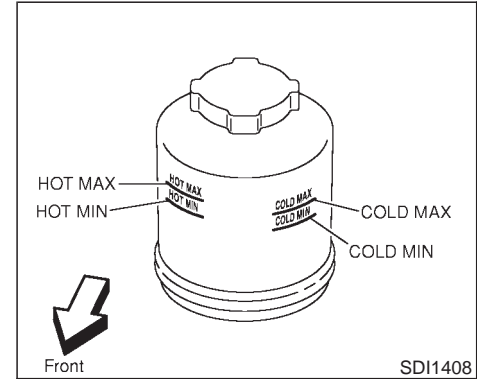

Check the fluid level in the reservoir tank.

The fluid level should be checked using the **HOT** range at fluid temperatures of 122 to 176°F (50 to 80°C) or using the **COLD** range at fluid temperatures of 32 to 86°F (0 to 30°C).



### **CAUTION**

- **Do not overfill.**
- **Use Genuine NISSAN PSF or equivalent.**

## BRAKE AND CLUTCH FLUID

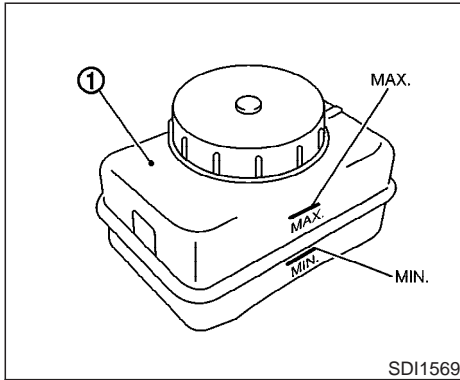

### BRAKE FLUID

Check the fluid level in the reservoir ①. If the fluid is below the MIN line or the brake warning light comes on, add Genuine Nissan Super Heavy Duty Brake Fluid or equivalent **DOT 3** fluid up to the MAX line. If fluid must be added frequently, the system should be thoroughly checked by your INFINITI dealer.



### WARNING

Use only new fluid. Old, inferior, or con

taminated fluid may damage the brake system. Do not add synthetic brake fluid. The use of improper fluids can damage the brake system and affect the vehicle's stopping ability.



### CAUTION

Do not spill the fluid on painted surfaces. This will damage the paint. If fluid is spilled, wash with water.

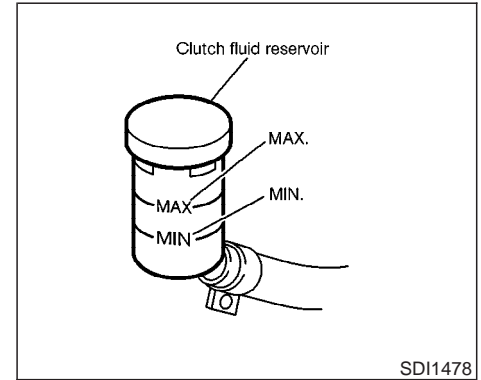

### CLUTCH FLUID

Check the fluid level in the reservoir. If the fluid level is below the MIN. line, add Genuine Nissan Super Heavy Duty Brake Fluid or equivalent DOT 3 fluid up to the MAX. line.

If fluid is added frequently, the system should be thoroughly checked by your INFINITI dealer.

## WINDOW WASHER FLUID

### WARNING

Use only new fluid from a sealed container. Old, inferior or contaminated fluid may damage the clutch system.

### CAUTION

Do not spill the fluid on painted surfaces. This will damage the paint. If fluid is spilled, wash the surface with water.

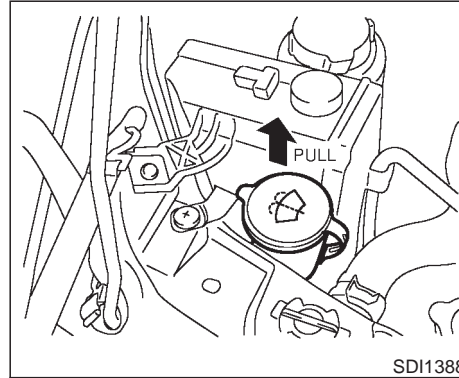

Add fluid when the low washer fluid warning light comes on. Add a washer solvent to the water for better cleaning. In the winter season, add a windshield washer antifreeze. Follow the manufacturer's instructions for the mixture ratio.

### WARNING

Antifreeze is poisonous and should be stored carefully in marked containers out of the reach of children.

### CAUTION

Do not substitute engine antifreeze coolant for window washer solution. This may result in damage to the paint.

## BATTERY

- Keep the battery surface clean and dry. Any corrosion should be washed off with a solution of baking soda and water.
- Make certain the terminal connections are clean and securely tightened.
- If the vehicle is not to be used for 30 days or longer, disconnect the (—) negative battery terminal cable to prevent discharging it.

### Coupe



#### CAUTION

When the battery cable is removed from the battery terminal, do not close either of front doors. The automatic window adjusting function will not work, and the side roof panel may be damaged.

To disconnect the negative (–) battery terminal, perform the procedure in the following order. Otherwise, the window and the side roof panel may contact and be damaged.

1. Close the windows.
2. Open the hood.
3. Close and lock all the doors.

4. Disconnect the negative (–) battery terminal.

5. Securely close the hood.

To connect the negative (–) battery terminal, perform the procedure in the following order. Otherwise, the window and the side roof panel may contact and be damaged.

1. Unlock and open the driver side door. Do not close the door.
2. Open the hood.
3. Connect the negative (–) battery terminal. Then close the hood.
4. Fully open the driver side door window.
5. Close the driver side door and the window.

### Sedan and coupe



#### WARNING

- Do not expose the battery to flames or electrical sparks. Hydrogen gas generated by battery action is explosive. Do not allow battery fluid to contact your skin, eyes, fabrics, or

Painted surfaces. After touching a battery or battery cap, do not touch or rub your eyes. Thoroughly wash your hands. If you get acid on your eyes, skin or clothing, immediately flush with water for at least 15 minutes and seek medical attention.

- Do not operate the vehicle if the battery fluid is low. Low battery fluid can cause a higher load on the battery which can generate heat, reduce battery life, and in some cases lead to an explosion.
- When working on or near a battery, always wear suitable eye protection and remove all jewelry.
- Battery posts, terminals and related accessories contain lead and lead compounds. Wash hands after handling.
- Keep the battery out of the reach of children.



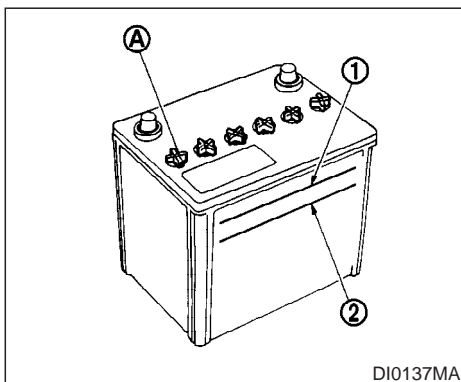

Check the fluid level in each cell. It should be between the UPPER LEVEL ① and LOWER LEVEL ② lines.

If it is necessary to add fluid, add only distilled water to bring the level to the indicator in each filler opening. **Do not overfill.**

Vehicles operated in high temperatures or under severe conditions require frequent checks of the battery fluid level.

1. Remove the cell plugs ①.
2. Add distilled water up to the UPPER LEVEL ①.

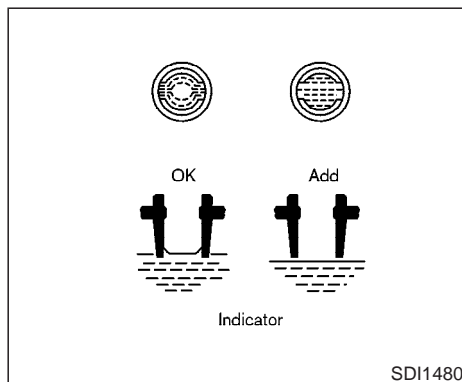

If the side of the battery is not visible, the electrolyte level can be checked through each filler opening as illustrated.

3. Tighten cell plugs ①.

## JUMP STARTING

If jump starting is necessary, see “Jump starting” in the “6. In case of emergency” section. If the engine does not start by jump starting, the battery may have to be replaced. Contact your INFINITI dealer.

## DRIVE BELTS

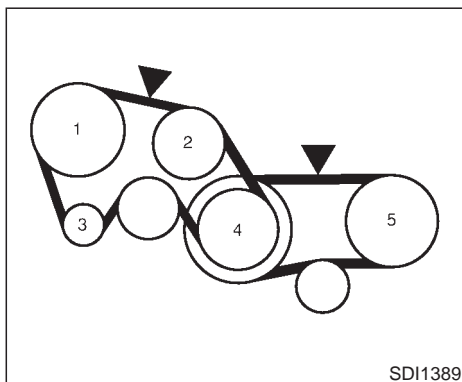

1. Power steering fluid pump
2. Fan
3. Alternator
4. Crankshaft pulley
5. Air conditioner compressor

▼: Tension checking points



### WARNING

Be sure the ignition key is in the OFF or LOCK position. The engine could rotate

unexpectedly.

1. Visually inspect each belt for signs of unusual wear, cuts, fraying, oil adhesion or looseness. If the belt is in poor condition or loose, have it replaced or adjusted by your INFINITI dealer.
2. Have the belts checked regularly for condition and tension in accordance with the maintenance schedule in the INFINITI Service and Maintenance Guide.

## SPARK PLUGS



### WARNING

Be sure the engine and ignition switch are off and that the parking brake is engaged securely.



### CAUTION

Be sure to use the correct socket to remove the spark plugs. An incorrect socket can damage the spark plugs.

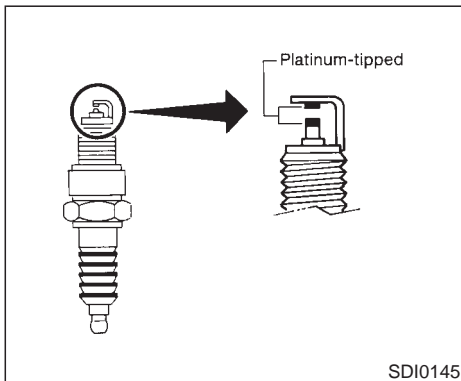

## REPLACING SPARK PLUGS

If replacement is required, see your INFINITI dealer for servicing.

### Platinum-tipped spark plugs

It is not necessary to replace the platinum-tipped spark plugs as frequently as the conventional type spark plugs since they will last much longer. Follow the maintenance schedule but, do not reuse them by cleaning or regapping.

**Always replace with recommended platinum-tipped spark plugs.**

## AIR CLEANER

If maintenance is required, see your INFINITI dealer for servicing.

The filter element should not be cleaned and reused. Replace it according to the maintenance intervals. See the INFINITI Service and Maintenance Guide. When replacing the filter, wipe the inside of the air cleaner housing and the cover with a damp cloth.



## WARNING

- Operating the engine with the air cleaner removed can cause you or others to be burned. The air cleaner not only cleans the air, it stops flames if the engine backfires. If it is not there, and the engine backfires, you could be burned. Do not drive with the air cleaner removed and be careful when working on the engine with the air cleaner removed.
- Never pour fuel into the throttle body or attempt to start the engine with the air cleaner removed. Doing so could result in serious injury.

## WINDSHIELD WIPER BLADES



## CAUTION

- After wiper blade replacement, return the wiper arm to its original position. Otherwise it may be damaged when the engine hood is opened.
- Make sure the wiper blade contacts the glass, otherwise the arm may be damaged from wind pressure.
- Worn windshield wiper blades can damage the windshield and impair driver vision.

## CLEANING

If your windshield is not clear after using the windshield washer or if a wiper blade chatters when running, wax or other material may be on the blade or windshield.

Clean the outside of the windshield with a washer solution or a mild detergent. Your windshield is clean if beads do not form when rinsing with clear water.

Clean the blade by wiping it with a cloth soaked in a washer solution or a mild deter-

gent. Then rinse the blade with clear water. If your windshield is still not clear after cleaning the blades and using the wiper, replace the blades.

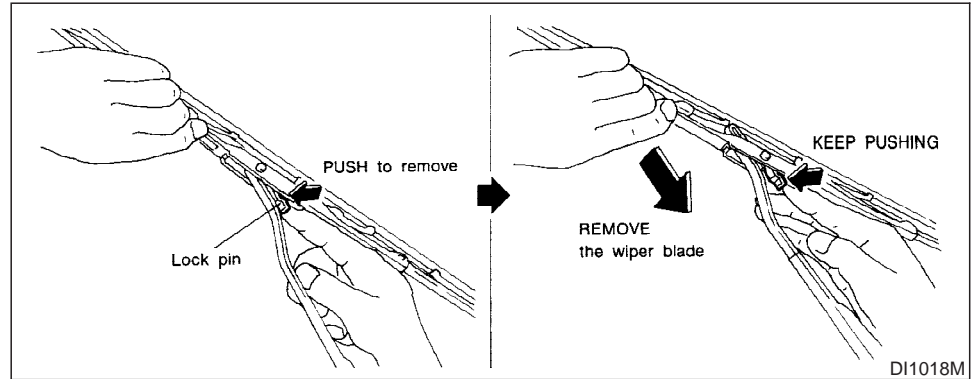

## REPLACING

Replace the wiper blades if they are worn.

1. Pull the wiper arm.
2. Push the lock pin, then remove the wiper blade.
3. Insert the new wiper blade to the wiper arm until a click sounds.

## PARKING BRAKE AND BRAKE PEDAL

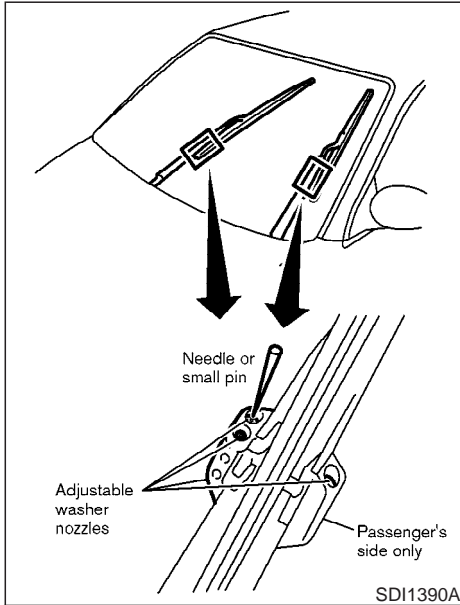

If necessary, clean the windshield washer nozzle with a needle or small pin.

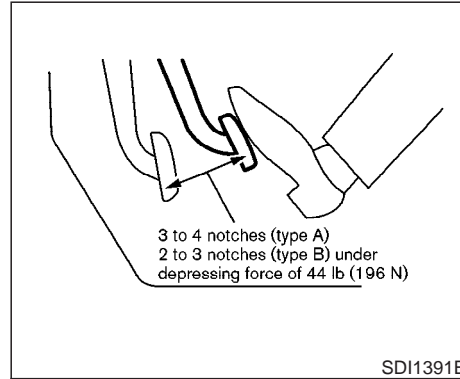

### CHECKING PARKING BRAKE

#### Pedal type

From the released position, depress the parking brake pedal slowly and firmly, and check the distance between the initial and final position of the pedal. If it is out of the range shown above, see your INFINITI dealer.

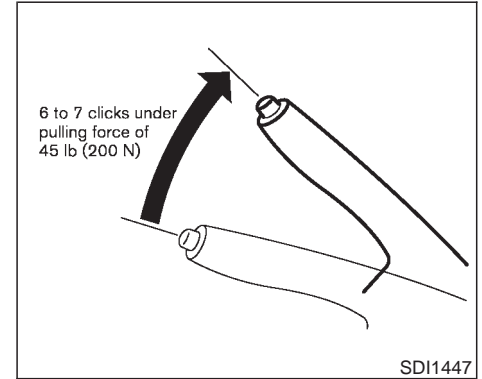

#### Lever type

From the released position, pull the parking brake lever up slowly and firmly. If the number of clicks is out of the range listed above, see your INFINITI dealer.

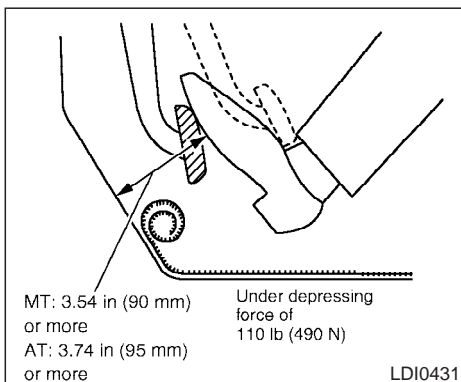

## CHECKING BRAKE PEDAL

With the engine running, check the distance between the upper surface of the pedal and the metal floor. If it is out of the range shown above, see your INFINITI dealer.

## Self-adjusting brakes

Your vehicle is equipped with self-adjusting brakes.

The disc-type brakes self-adjust every time the brake pedal is applied.



## WARNING

See your INFINITI dealer and have it checked if the brake pedal height does not return to normal.

## Brake pad wear indicators

The disc brake pads on your vehicle have audible wear indicators. When a brake pad requires replacement, it will make a high pitched scraping or screeching sound when the vehicle is in motion whether or not the brake pedal is depressed. Have the brakes checked as soon as possible if the wear indicator sound is heard.

Under some driving or climate conditions, occasional brake squeak, squeal or other noise may be heard. Occasional brake noise during light to moderate stops is normal and does not affect the function or performance of the brake system.

**Proper brake inspection intervals should be followed.** For additional information, see the appropriate maintenance log shown in the INFINITI Service and Maintenance Guide.

High performance sports brake pads occasionally make squeaks, squeals or other braking noises because of their very high friction coefficient.

These occasional brake noises are normal, but if they continue, see your INFINITI dealer.

## BRAKE BOOSTER

Check the brake booster function as follows:

1. With the engine off, press and release the brake pedal several times. When brake pedal movement (distance of travel) remains the same from one pedal application to the next, continue on to the next step.
2. While depressing the brake pedal, start the engine. The pedal height should drop a little.
3. With the brake pedal depressed, stop the engine. Keeping the pedal depressed for about 30 seconds, the pedal height should not change.
4. Run the engine for one minute without depressing the brake pedal, then turn it off. Depress the brake pedal several times. The pedal travel distance will decrease gradually with each depression as the vacuum is released from the booster.

## FUSES

If the brakes do not operate properly, see your INFINITI dealer.



### CAUTION

Never use a fuse of higher or lower amperage rating than that specified on the fuse box cover. This could damage the electrical system or cause a fire.

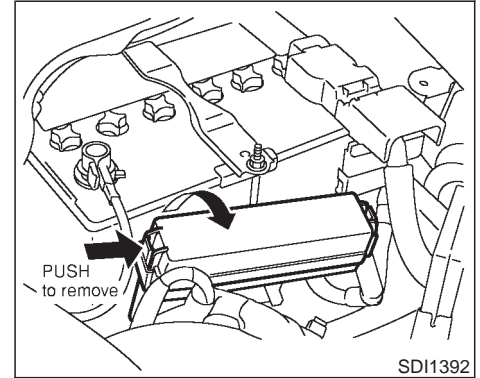

## ENGINE COMPARTMENT

If any electrical equipment does not operate, check for an open fuse.

1. Be sure the ignition key and headlight switch are OFF.
2. Open the engine hood and remove the cover on the battery and the fuse/fusible link holder.
3. Remove the fuse/fusible link holder cover.
4. Remove the fuse with the fuse puller.
5. If the fuse is open, replace it with a new fuse.

6. If a new fuse also opens, have the electrical system checked and repaired by your INFINITI dealer.

### Fusible links

If any electrical equipment does not operate and fuses are in good condition, check the fusible links. If any of these fusible links are melted, replace only with genuine NISSAN parts.

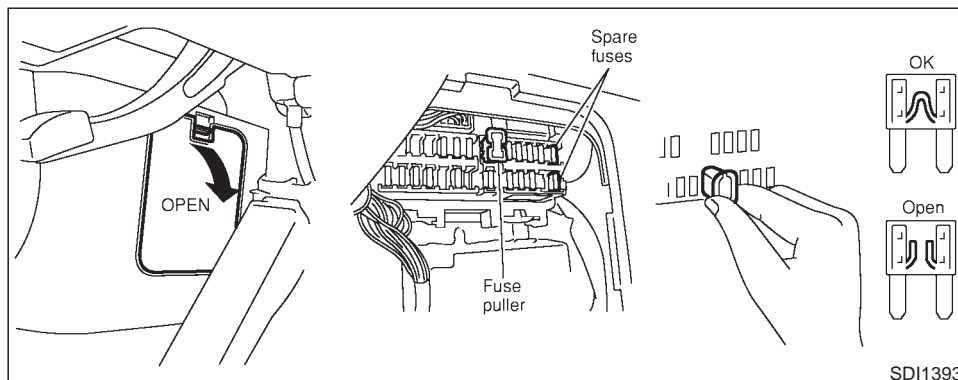

SDI1393

### PASSENGER COMPARTMENT

If any electrical equipment does not operate, check for an open fuse.

1. Be sure the ignition key and the headlight switch are OFF.
2. Open the fuse box lid.
3. Remove the fuse with the fuse puller.
4. If the fuse is open, replace it with a new fuse.
5. If a new fuse also opens, have the electrical system checked and repaired by your INFINITI dealer.



## KEYFOB BATTERY REPLACEMENT

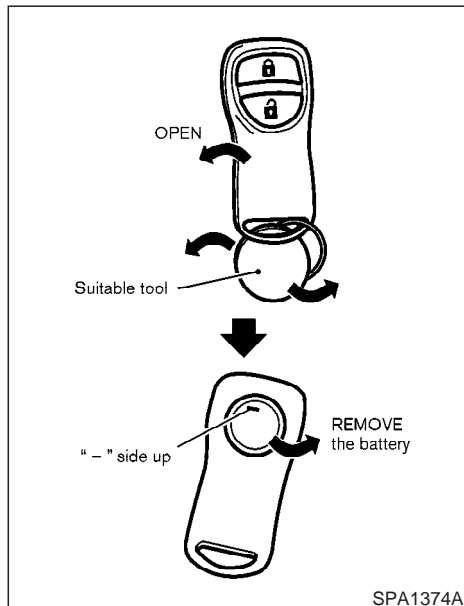

Replace the battery as follows:

1. Open the lid using a suitable tool.
2. Replace the battery with a new one.  
Recommended battery: CR2025 or equivalent

Make sure that the ⊕ side faces the bottom case.

3. Close the lid securely.
4. Push the keyfob button two or three times to check its operation.

See your INFINITI dealer if you need any assistance for replacement.

If the battery is removed for any reason other than replacement, perform step 4 above.

- Be careful not to touch the circuit board and the battery terminal.
- An improperly disposed battery can harm the environment. Always confirm local regulations for battery disposal.
- The keyfob is water-resistant; however, if it gets wet, immediately wipe it completely dry.
- When changing batteries, do not let dust or oil get on the keyfob.

### FCC Notice:

Changes or modifications not expressly approved by the manufacturer compliance could void the user's authority to operate the equipment. This device complies with Part 15 of the FCC Rules and RSS-210 of

Industry Canada. Operation is subject to the following two conditions: (1) This device may not cause harmful interference, and (2) this device must accept any interference received, including interference that may cause undesired operation of the device.

## LIGHTS

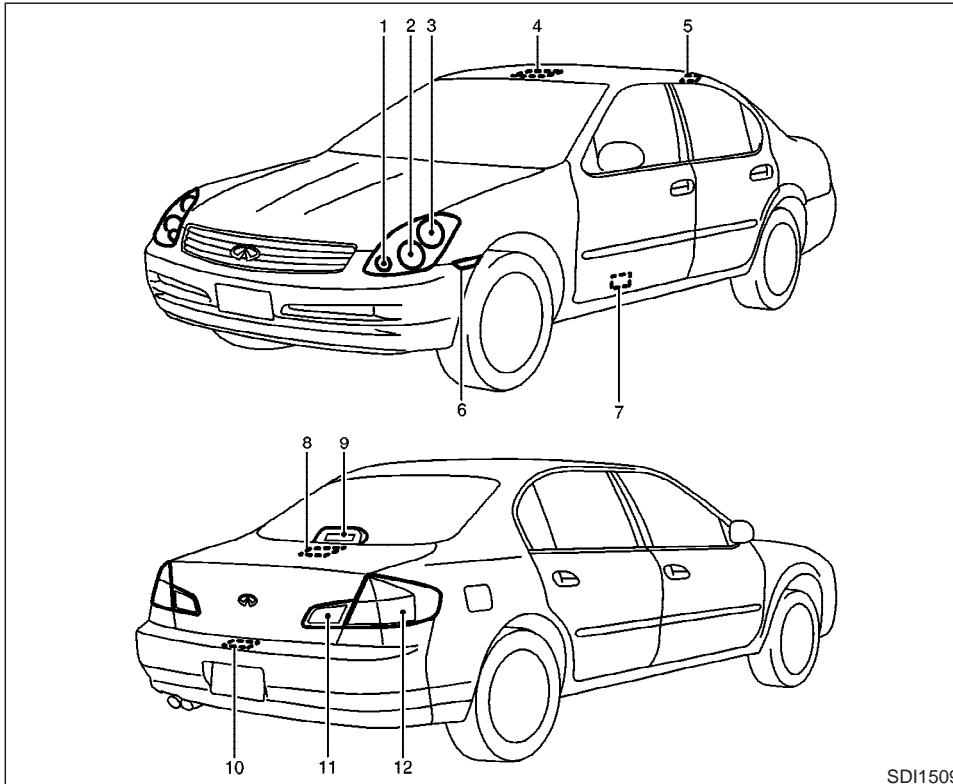

### Sedan

1. Front turn signal light
2. Front fog light/Headlight (high-beam) and clearance light
3. Headlight (low-beam)
4. Map light
5. Rear personal light
6. Front side marker light
7. Step light
8. Trunk light
9. High-mounted stop light (if so equipped)
10. License plate light
11. Back-up light
12. Rear combination light  
(Turn signal, Stop/Tail, Side marker)

SDI1509

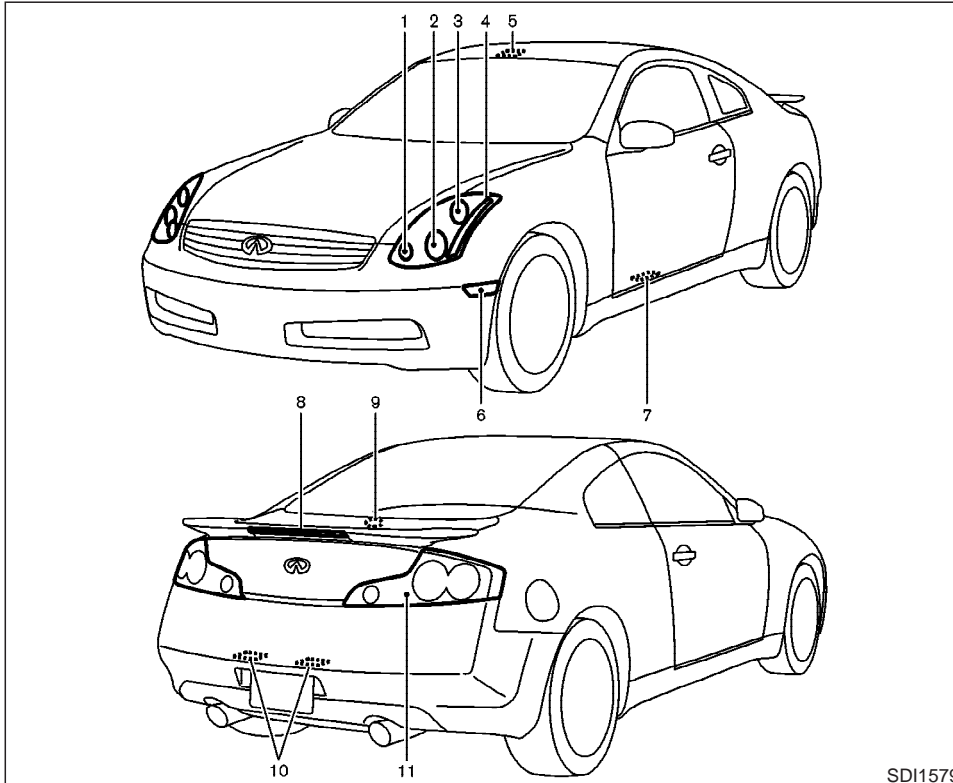

SDI1579

## Coupe

1. Front turn signal light, clearance light
2. Front fog light/Headlight (high-beam)
3. Headlight (low-beam)
4. Clearance light
5. Map light
6. Front side marker light
7. Step light
8. High-mounted stop light (if so equipped)
9. Trunk light
10. License plate light
11. Rear combination light  
(Turn signal, Stop/Tail, Back-up, Side marker)

## HEADLIGHTS

### Replacing

If replacement is required, see an authorized INFINITI dealer.

#### Xenon headlight bulb:



### WARNING



### HIGH VOLTAGE

When xenon headlights are on, they produce a high voltage. To prevent an electric shock, never attempt to modify or disassemble the headlight assembly. Always have your xenon headlights replaced at an authorized INFINITI dealer. For additional information, see “Headlight and turn signal switch” in the “2. Instruments and controls” section.

#### Halogen headlight bulb:

A bulb can be replaced from under the engine compartment without removing the headlight assembly. Replacement should be done by an INFINITI dealer.



### CAUTION

- High pressure halogen gas is sealed inside the halogen bulb. The bulb may break if the glass envelope is scratched or the bulb is dropped.
- When handling the bulb, do not touch the glass envelope.
- Do not touch the bulb.
- Use the same number and wattage as originally installed:  
Bulb no. H1 (55W) - Low-beam  
HB2 (60/55W) - High-beam/  
Fog light
- Do not leave the bulb out of the headlight reflector for a long period of time as dust, moisture, and smoke may enter the headlight body and affect the performance of the headlight.

## EXTERIOR AND INTERIOR LIGHTS

Item	Wattage (W)	Bulb No.
Front turn signal*	21	T20
Clearance light*	5	T10
Front side marker light	3.8	T10
Rear combination light		
Turn signal	21	T20
Stop/Tail*	(LED)	—
Side marker light*	Sedan: (LED)/Coupe: 3.8	Sedan: —/Coupe: T10
Back-up light	18	T16
License plate light	5	T10
High-mounted stop light*	(LED)	—
Map light	8	—
Rear personal light (Sedan)	8	—
Step light	5	—
Trunk light	3.4	158
Vanity mirror light (if so equipped)	1.32	—

\*: See an authorized INFINITI dealer for replacement.

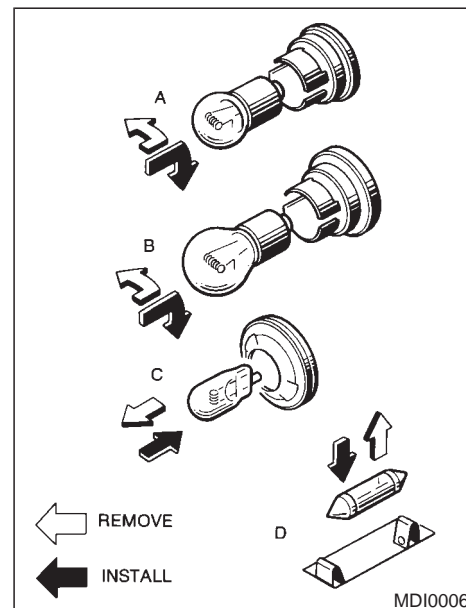

### Replacement procedures

All other lights are either type A, B, C or D. When replacing a bulb, first remove the lens and/or cover.

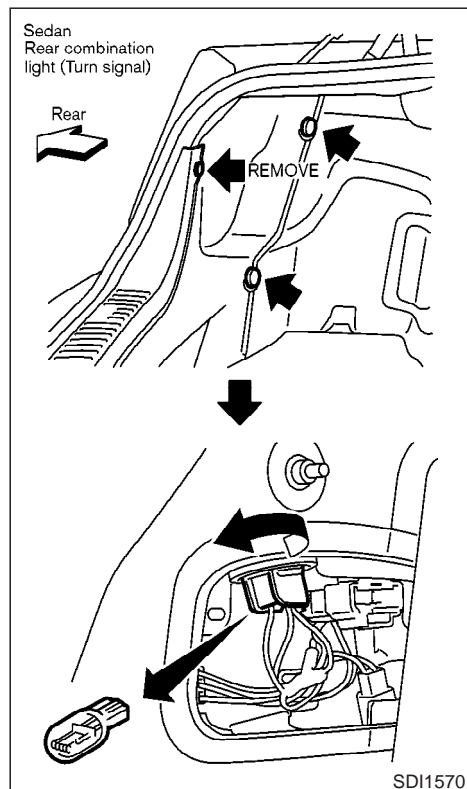
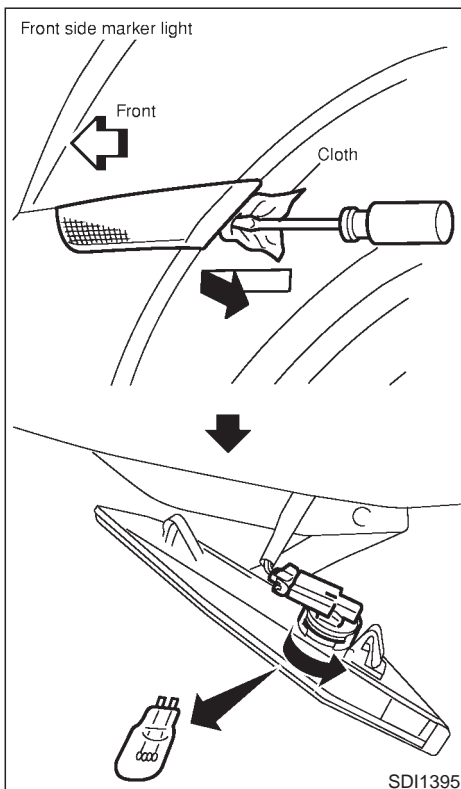

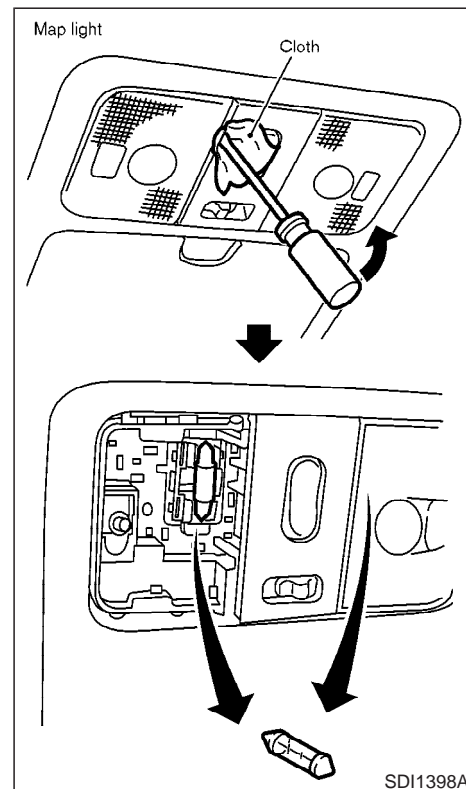
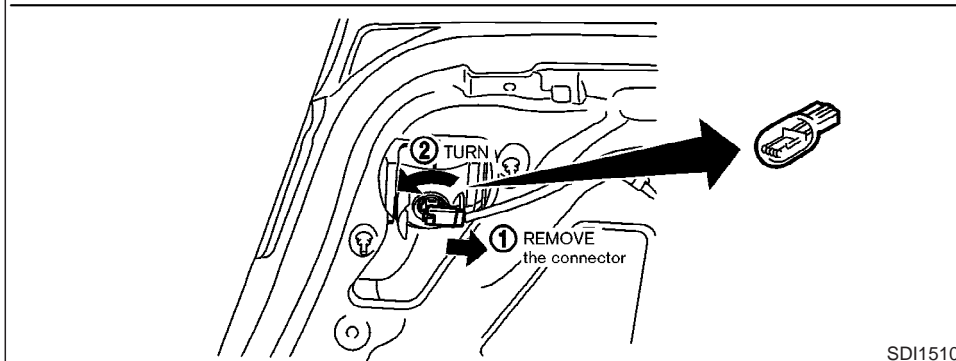
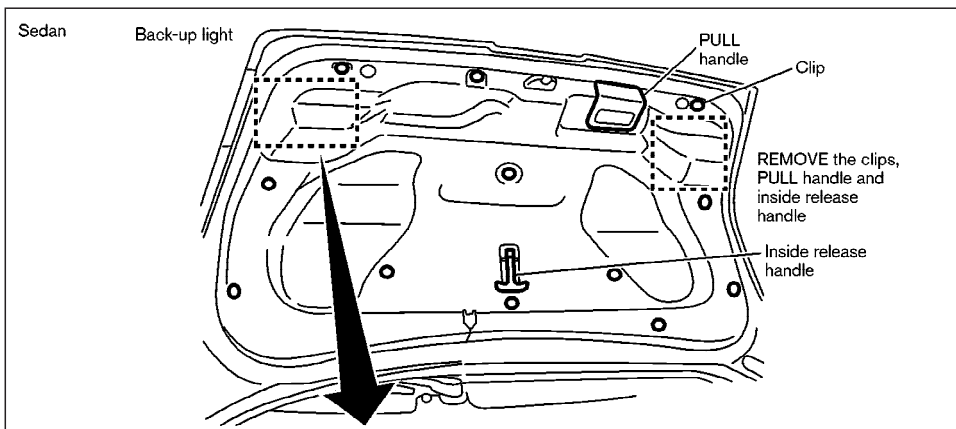

Rear personal light (Sedan)

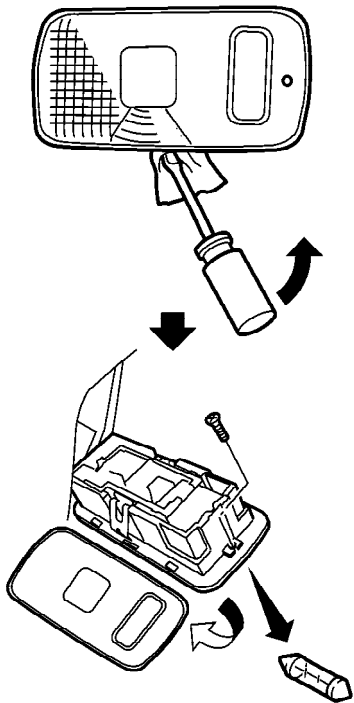

SDI1399A

Step light

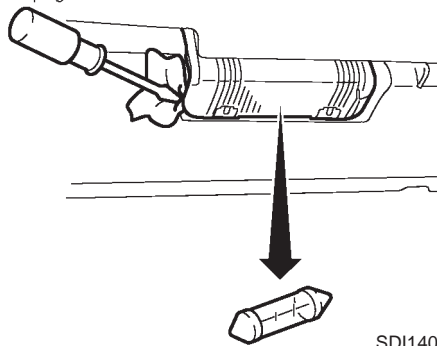

SDI1400

Vanity mirror light  
(if so equipped)

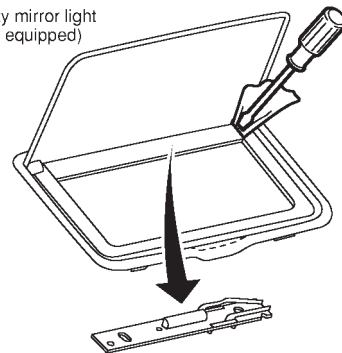

SDI1407

Trunk light

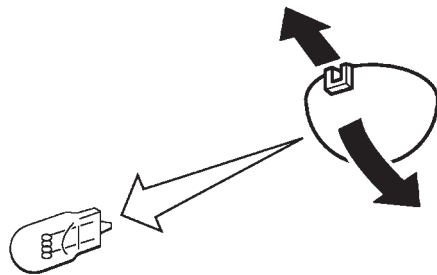

SDI1258

License plate light

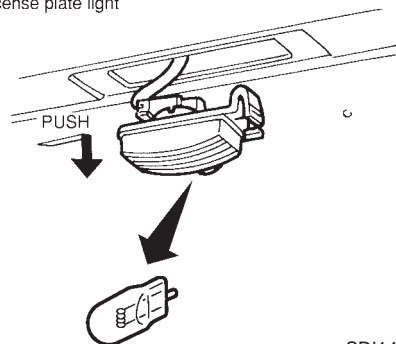

SDI1401



## WHEELS AND TIRES

### TIRE PRESSURE

#### Tire inflation pressure

Check the tire pressure of the tires (including the spare) often and always prior to long distance trips. The recommended tire pressure specifications are shown on the Tire and Loading Information label under the “Recommended Cold Tire Inflation Pressure” heading. The Tire and Loading Information label is affixed to the driver side center pillar. Tire pressures should be checked regularly because:

- Most tires naturally lose air over time.
- Tires can lose air suddenly when driven over potholes or other objects or if the vehicle strikes a curb while parking.

The tire pressures should be checked when the tires are cold. The tires are considered COLD after the vehicle has been parked for 3 or more hours, or driven less than 1 mile (1.6 km) at moderate speeds.

**Incorrect tire pressure, including under inflation, may adversely affect tire life and vehicle handling.**



### WARNING

- **Improperly inflated tires can fail suddenly and cause an accident.**
- **The vehicle weight capacity is indicated on the Tire and Loading Information label. Do not load your vehicle beyond this capacity. Overloading your vehicle may result in reduced tire life, unsafe operating conditions due to premature tire failure, or unfavorable handling characteristics and could also lead to a serious accident. Loading beyond the specified capacity may also result in a malfunction of other vehicle components.**
- **Before taking a long trip, or whenever you heavily load your vehicle, use a tire pressure gauge to ensure that the tire pressures are at the specified level.**
- **Do not drive your vehicle over 85 MPH (137 km/h) unless it is equipped with high-speed rated tires. Driving**

**faster than 85 MPH (137 km/h) may result in tire malfunction, loss of control and possible injury.**

- **For additional information regarding tires, refer to “Important Tire Safety Information” (US) or “Tire Safety Information” (Canada) in the Warranty Information Booklet.**

#### Low tire pressure warning system

The low tire pressure warning system monitors the tire pressure of all tires (except the spare tire) by sending a signal from a sensor that is installed in each wheel. For more details, refer to “Low tire pressure warning light” in the “2. Instruments and controls” section, “Low tire pressure warning system” in the “5. Starting and driving” section, and “Flat tire” in the “6. In case of emergency” section. The low tire pressure warning system will activate only when the vehicle is driven at speeds above 20 MPH (32 km/h).

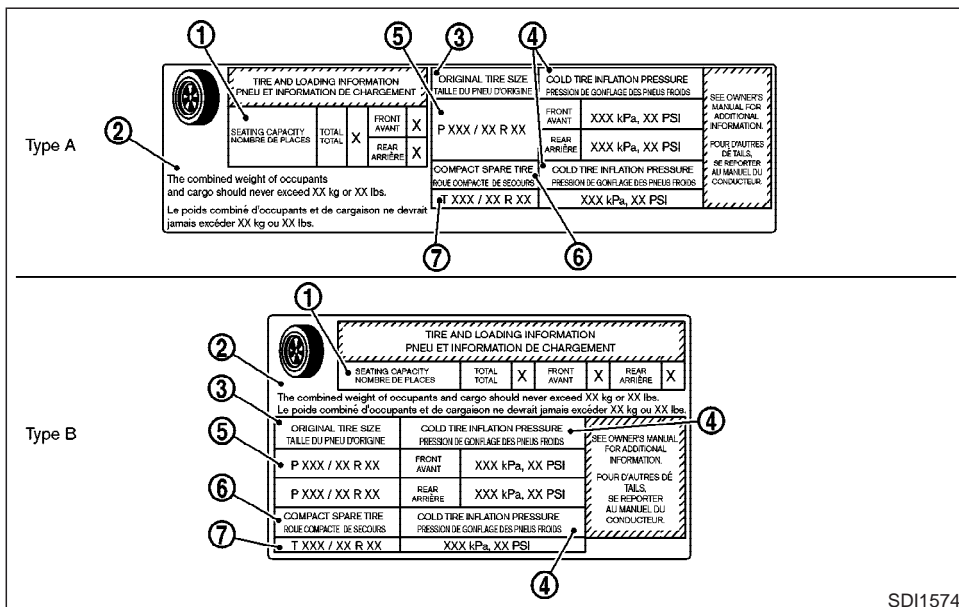

④ Recommended cold tire inflation pressure: Inflate the tires to this pressure when the tires are cold. Tires are considered COLD after the vehicle has been parked for 3 or more hours, or driven less than 1 mile (1.6 km) at moderate speeds. The recommended cold tire inflation is set by the manufacturer to provide the best balance of tire wear, vehicle handling characteristics, driveability, tire noise, etc. based on the vehicle's GVWR.

⑤ Tire size — refer to “Tire labeling” later in this section.

⑥ and ⑦ Spare tire size or compact spare tire size (if so equipped)

### Checking the tire pressure

1. Remove the valve stem cap from the tire.
2. Press the pressure gauge squarely onto the valve stem. Do not press too hard or force the valve stem sideways, or air will escape. If the hissing sound of air escaping from the tire is heard while checking the pressure, reposition the gauge to eliminate this leakage.
3. Remove the gauge.
4. Read the tire pressure on the gauge stem and compare it to the specification shown

### Tire and loading information label

① Seating capacity: The maximum number of occupants that can be seated in the vehicle.

② Vehicle load limit: See loading information in the Technical and consumer information section.

③ Original tire size: The size of the tires originally installed on the vehicle at the factory.

on the Tire and Loading Information label.

5. Add air to the tire as needed. If too much air is added, press the core of the valve stem briefly with the tip of the gauge stem to release pressure. Recheck the pressure and add or release air as needed.
6. Install the valve stem cap.
7. Check the pressure of all other tires, including the spare. (Refer to the "Wheels and tires" section)

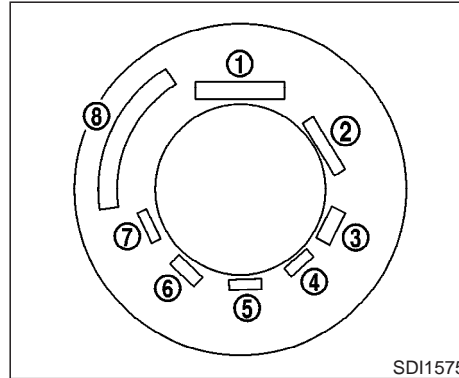

## TIRE LABELING

Federal law requires tire manufacturers to place standardized information on the sidewall of all tires. This information identifies and describes the fundamental characteristics of the tire and also provides the tire identification number (TIN) for safety standard certification. The TIN can be used to identify the tire in case of a recall.

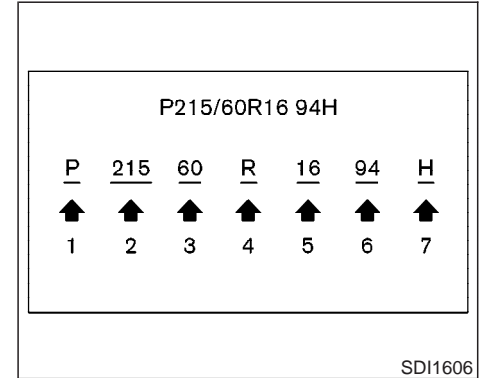

① Tire size (example: P215/60R16 94H)

1. P: The "P" indicates the tire is designed for passenger vehicles. (Not all tires have this information.)
2. Three-digit number (215): This number gives the width in millimeters of the tire from sidewall edge to sidewall edge.
3. Two-digit number (60): This number, known as the aspect ratio, gives the tire's ratio of height to width.
4. R: The "R" stands for radial.

5. Two-digit number (16): This number is the wheel or rim diameter in inches.
6. Two- or three-digit number (94): This number is the tire's load index. It is a measurement of how much weight each tire can support. You may not find this information on all tires because it is not required by law.
7. H: Speed Rating. The speed rating denotes the speed at which a tire is designed to be driven for extended periods of time. The ratings range from 98 miles per hour (MPH) to 186 MPH. (You may not find this information on all tires because it is not required by law.)

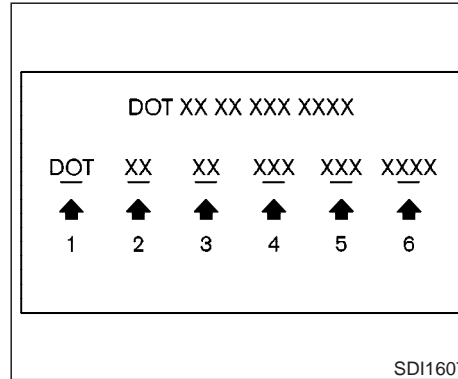

6. Four numbers represent the week and year the tire was built. For example, the numbers 3103 means the 31st week of 2003.

- ② TIN (Tire Identification Number) for new tire (example: DOT XX XX XXX XXXX)
  1. DOT: Abbreviation for the "Department of Transportation". The symbol can be placed above, below or to the left or right of the Tire Identification Number.
  2. Two-digit code: Manufacturer's identification mark
  3. Two-digit code: Tire size
  4. Three-digit code: Tire type code (Optional)
  5. Four-digit code: Date of Manufacture

- ③ **Tire ply composition and material**  
The number of layers or plies of rubber-coated fabric in the tire.  
Tire manufacturers also must indicate the materials in the tire, which include steel, nylon, polyester, and others.
- ④ **Maximum permissible inflation pressure**  
This number is the greatest amount of air pressure that should be put in the tire. Do not exceed the maximum permissible inflation pressure.
- ⑤ **Maximum load rating**  
This number indicates the maximum load in kilograms and pounds that can be carried by the tire. When replacing the tires on the vehicle, always use a tire that has the same load rating as the factory installed tire.
- ⑥ **Term of “tubeless” or “tube type”**  
Indicates that the tire requires an inner tube (“tube type”) or not (“tubeless”).
- ⑦ **The word “radial”**  
The word “radial” is shown, if the tire has radial structure.
- ⑧ **Manufacturer or Brand name**  
Manufacturer or Brand name is shown.

### Other tire-related terminology

In addition to the many terms that are defined

throughout this section, Intended Outboard Sidewall is (1) the sidewall that contains a whitewall, bears white lettering or bears manufacturer, brand and/or model name molding that is higher or deeper than the same molding on the other sidewall of the tire, or (2) the outward facing sidewall of an asymmetrical tire that has a particular side that must always face outward when mounted on a vehicle.

## TYPES OF TIRES



### WARNING

- **When changing or replacing tires, be sure all four tires are of the same type (i.e., summer, all season or snow) and construction. An INFINITI dealer may be able to help you with information about tire type, size, speed rating and availability.**
- **Replacement tires may have a lower speed rating than the factory equipped tires, and may not match the potential maximum vehicle speed. Never exceed the maximum speed rating of the tire.**
- **For additional information regarding tires, refer to “Important Tire Safety Information” (US) or “Tire Safety Information” (Canada) in the Warranty Information Booklet.**

### All season tires

INFINITI specifies all season tires on some models to provide good performance for use all year round, including snowy and icy road

conditions. All season tires are identified by ALL SEASON and/or M&S on the tire sidewall. Snow tires have better snow traction than all season tires and may be more appropriate in some areas.

### Summer tires

INFINITI specifies summer tires on some models to provide superior performance on dry roads. Summer tire performance is substantially reduced in snow and ice. Summer tires do not have the tire traction rating M&S on the tire sidewall.

If you plan to operate your vehicle in snowy or icy conditions, INFINITI recommends the use of snow or all season tires on all four wheels.

### Snow tires

If snow tires are needed, it is necessary to select tires equivalent in size and load rating to the original equipment tires. If you do not, it can adversely affect the safety and handling of your vehicle.

Generally, snow tires will have lower speed ratings than factory equipped tires and may not match the potential maximum vehicle speed. Never exceed the maximum speed rating of the tire.

If you operate your vehicle in snowy or icy

conditions, INFINITI recommends the use of snow or all season tires on all four wheels.

For additional traction on icy roads, studded tires may be used. However, some provinces and states prohibit their use. Check local, state and provincial laws before installing studded tires. Skid and traction capabilities of studded snow tires, on wet or dry surfaces, may be poorer than that of non-studded snow tires.

### All wheel drive models



### CAUTION

- **Always use tires of the same size, brand, construction (bias, bias-belted or radial), and tread pattern on all four wheels. Failure to do so may result in a circumference difference between tires on the front and rear axles which will cause excessive tire wear and may damage the transmission, transfer case and differential gears.**
- **ONLY use spare tires specified for the AWD model.**

If excessive tire wear is found, it is recommended that all four tires be replaced with tires

of the same size, brand, construction and tread pattern. The tire pressure and wheel alignment should also be checked and corrected as necessary. Contact your INFINITI dealer.

**Tire chains must be installed only on the rear wheels and not on the front wheels.**

Do not drive with tire chains on paved roads which are clear of snow. Driving with chains in such conditions can cause damage to the various mechanisms of the vehicle due to some overstress.

### TIRE CHAINS

Use of tire chains may be prohibited according to location. Check the local laws before installing tire chains. When installing tire chains, make sure they are of proper size for the tires on your vehicle and are installed according to the chain manufacturer's instructions. **Use only SAE class S chains.** Class "S" chains are used on vehicles with restricted tire to vehicle clearance. Vehicles that can use Class "S" chains are designed to meet the SAE standard minimum clearances between the tire and the closest vehicle suspension or body component required to accommodate the use of a winter traction device (tire chains or cables). The minimum clearances are determined using the factory equipped tire size.

Other types may damage your vehicle. Use chain tensioners when recommended by the tire chain manufacturer to ensure a tight fit. Loose end links of the tire chain must be secured or removed to prevent the possibility of whipping action damage to the fenders or undercarriage. If possible, avoid fully loading your vehicle when using tire chains. In addition, drive at a reduced speed. Otherwise, your vehicle may be damaged and/or vehicle handling and performance may be adversely affected.

Tire chains must be installed only on the rear wheels and not on the front wheels.

**Never install tire chains on a T-type spare tire (TEMPORARY USE ONLY). Do not use the chains on dry roads.**

Driving with chains in such conditions can cause damage to the various mechanisms of the vehicle due to some overstress.

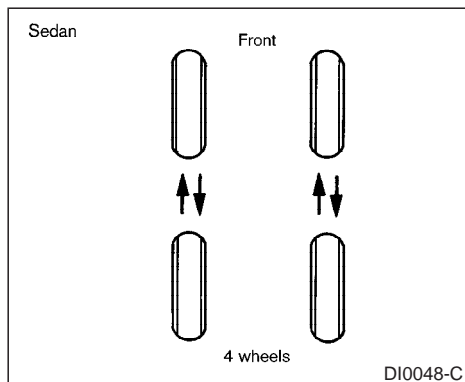

## CHANGING WHEELS AND TIRES

### Tire rotation (Sedan)

INFINITI recommends rotating the tires every 7,500 miles (12,000 km). See “Flat tire” in the “In case of emergency” section for tire replacing procedures.

As soon as possible, tighten the wheel nuts to the specified torque with a torque wrench.

**Wheel nut tightening torque:  
80 ft-lb (108 N·m)**

The wheel nuts must be kept tightened to specification at all times. It is recommended

that wheel nuts be tightened to specification at each tire rotation interval.

### Tire rotation (Coupe)

Tires cannot be rotated on this vehicle, as front tires are a different size from rear tires and the direction of the wheel rotation is fixed for each tire.

A pin is on the front brake rotor to prevent the rear wheels from being installed in place of the front wheels. The spare tire can be installed in place of the front and rear wheels. When installing the spare tire in the front wheel, the hole in the spare tire wheel must be aligned with the pin on the brake rotor.



## WARNING

- After rotating the tires, adjust the tire pressure.
- Retighten the wheel nuts when the vehicle has been driven for 600 miles (1,000 km) (also in cases of a flat tire, etc.).
- Do not include the T-type spare tire or any other small size spare tire in the tire rotation.

- For additional information regarding tires, refer to “Important Tire Safety Information” (US) or “Tire Safety Information” (Canada) in the Warranty Information Booklet.

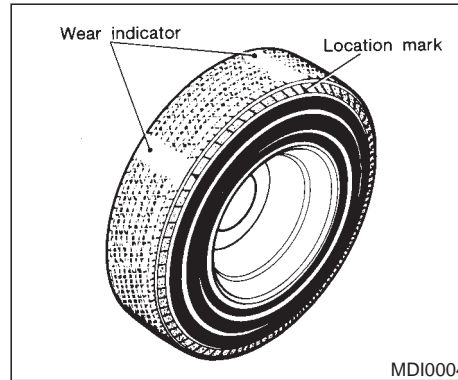

MDI0004

### Tire wear and damage



#### WARNING

- Tires should be periodically inspected for wear, cracking, bulging, or objects caught in the tread. If excessive wear, cracks, bulging, or deep cuts are found, the tire should be replaced.
- The original tires have a built-in tread wear indicator. When the wear indica-

tor is visible, the tire should be replaced.

- Improper service of a spare tire may result in serious personal injury. If it is necessary to repair the spare tire, contact your INFINITI dealer.
- For additional information regarding tires, refer to “Important Tire Safety Information” (US) or “Tire Safety Information” (Canada) in the Warranty Information Booklet.

### Replacing wheels and tires

When replacing a tire, use the same size, speed rating and load carrying capacity as originally equipped. See “Specifications” in the “9. Technical and consumer information” section for recommended types and sizes of tires and wheels.



#### WARNING

- The use of tires other than those recommended or the mixed use of



tires of different brands, construction (bias, bias-belted or radial), or tread patterns can adversely affect the ride, braking, handling, ground clearance, body-to-tire clearance, tire chain clearance, speedometer calibration, headlight aim and bumper height. Some of these effects may lead to accidents and could result in serious personal injury.

- If the wheels are changed for any reason, always replace with wheels which have the same offset dimension. Wheels of a different offset could cause early tire wear, possibly degraded vehicle handling characteristics and/or interference with the brake discs. Such interference can lead to decreased braking efficiency and/or early brake pad wear.
- When a spare tire is mounted or a wheel is replaced, the low tire pressure warning system will not function. Contact your INFINITI dealer as soon as possible for tire replacement

and/or system resetting. (For models with the low tire pressure warning system)

- Do not install a deformed wheel or tire even if it has been repaired. Such wheels or tires could have structural damage and could malfunction without warning.
- The use of retread tires is not recommended.
- For additional information regarding tires, refer to “Important Tire Safety Information” (US) or “Tire Safety Information” (Canada) in the Warranty Information Booklet.



## CAUTION

- Always use tires of the same size, brand, construction (bias, bias-belted or radial), and tread pattern on all four wheels. Failure to do so may result in a circumference difference between tires on the front and rear axles which

**will cause excessive tire wear and may damage the transmission, transfer case and differential gears (AWD models).**

## Wheel balance

Unbalanced wheels may affect vehicle handling and tire life. Even with regular use, wheels can get out of balance. Therefore, they should be balanced as required.

Wheel balance service should be performed with the wheels off the vehicle. Spin balancing the wheels on the vehicle could lead to mechanical damage.

For additional information regarding tires, refer to “Important Tire Safety Information” (US) or “Tire Safety Information” (Canada) in the INFINITI Warranty Information Booklet.

## Care of wheels

- Wash the wheels when washing the vehicle to maintain their appearance.
- Clean the inner side of the wheels when the wheel is changed or the underside of the vehicle is washed.

- Do not use abrasive cleaners when washing the wheels.
- Inspect wheel rims regularly for dents or corrosion. Such damage may cause loss of pressure or poor seal at the tire bead.
- INFINITI recommends that the road wheels be waxed to protect against road salt in areas where it is used during winter.

### Spare tire (TEMPORARY USE ONLY spare tire (T-type))

Observe the following precautions if the T-type spare tire must be used, otherwise your vehicle could be damaged or involved in an accident.



### CAUTION

- The T-type spare tire should be used only for an emergency. It should be replaced by a standard tire at the first opportunity.
- Drive carefully while the T-type spare tire is installed.  
Avoid sharp turns and abrupt braking while driving.

- Periodically check the T-type spare tire inflation pressure, and always keep it at 60 psi (420 kPa, 4.2 bar).
- With the T-type spare tire installed, do not drive your vehicle at speeds faster than 50 MPH (80 km/h).
- When driving on roads covered with snow or ice, the T-type spare tire should be used on the front wheel and the original tire used on the rear wheels (drive wheels). Use tire chains only on the rear two original tires. (Sedan)
- Tire tread of the T-type spare tire will wear at a faster rate than the original tire. Replace the T-type spare tire as soon as the tread wear indicators appear.
- Do not use the T-type spare tire on other vehicles.
- Do not use more than one T-type spare tire at the same time.
- Do not tow a trailer while the T-type spare tire is installed.



### CAUTION

- Do not use tire chains on a T-type spare tire. Tire chains will not fit properly on the T-type spare tire and may cause damage to the vehicle.
- Because the T-type spare tire is smaller than the original tire, ground clearance is reduced. To avoid damage to the vehicle do not drive over obstacles. Also do not drive the vehicle through an automatic car wash since it may get caught.

# 9 Technical and consumer information

Capacities and recommended fuel/lubricants .....	9-2	Installing front bumper cover.....	9-12
Fuel recommendation.....	9-3	Installing front license plate.....	9-13
Engine oil and oil filter recommendation.....	9-5	Vehicle loading information.....	9-14
Recommended SAE viscosity number.....	9-6	Terms .....	9-14
Air conditioning system refrigerant and lubricant recommendations .....	9-6	Vehicle load capacity .....	9-15
Specifications .....	9-7	Loading tips .....	9-15
Engine .....	9-7	Towing a trailer .....	9-16
Wheels and tires .....	9-8	Maximum load limits.....	9-16
Dimensions and weights .....	9-8	Towing load/specification .....	9-17
When traveling or registering your vehicle in another country.....	9-9	Towing safety .....	9-17
Vehicle identification .....	9-9	Flat towing .....	9-19
Vehicle identification number (VIN) plate.....	9-9	Uniform tire quality grading.....	9-20
Vehicle identification number (Chassis number)..	9-9	Emission control system warranty .....	9-21
Engine serial number .....	9-10	Reporting safety defects (US only).....	9-22
F.M.V.S.S. certification label .....	9-10	Readiness for inspection/maintenance (I/M) test (US only).....	9-22
Emission control information label .....	9-11	Event data recorders.....	9-23
Tire and Loading Information label .....	9-11	Owner's Manual/Service Manual order information .....	9-24
Air conditioner specification label.....	9-12	In the event of a collision .....	9-24

## CAPACITIES AND RECOMMENDED FUEL/LUBRICANTS

The following are approximate capacities. The actual refill capacities may be slightly different. When refilling, follow the procedure instructed in the “8. Maintenance and do-it-yourself” section to determine the proper refill capacity.

	Capacity (Approximate)			Recommended specifications
	US measure	Imp measure	Liter	
Fuel	20 gal	16-5/8 gal	76	Unleaded gasoline with an octane rating of at least 91 AKI (RON 96)*1
Engine oil*8 Drain and refill				
With oil filter change	5 qt	4-1/8 qt	4.7	<ul style="list-style-type: none"> <li>• API Certification Mark*2, *3</li> <li>• API grade SG/SH, Energy Conserving I &amp; II or API grade SJ or SL, Energy Conserving*2, *3</li> <li>• ILSAC grade GF-I, GF-II &amp; GF-III*2, *3</li> </ul>
Without oil filter change	4-5/8 qt	3-7/8 qt	4.4	
Cooling system				
With reservoir	Sedan AT 9 qt	7-1/2 qt	8.5	Genuine Nissan Long Life Antifreeze/Coolant or equivalent
	Coupe, Sedan MT 9-1/4 qt	7-5/8 qt	8.7	
Reservoir	7/8 qt	3/5 qt	0.8	
Automatic transmission fluid	—	—	—	Genuine Nissan Matic J ATF*4
Manual transmission gear oil	—	—	—	Genuine Nissan Manual Transmission Fluid (MTF) HQ Multi 75W-85 or API GL-4, Viscosity SAE 75W-85 or 75W-90
Differential gear oil	—	—	—	API GL-5, Viscosity SAE 80W-90*5
Transfer fluid	—	—	—	Genuine Nissan Matic D ATF (Continental U.S. and Alaska) or CANADA NISSAN Automatic Transmission Fluid*6
Power steering fluid (PSF)				
Power steering fluid (PSF)	Refill to the proper oil level according to the instructions in the “8. Maintenance and do-it-yourself” section.			Genuine NISSAN PSF or equivalent*10
Brake and clutch fluid				Genuine Nissan Super Heavy Duty Brake Fluid*7 or equivalent DOT 3 (U.S. FMVSS No. 116)
Multi-purpose grease	—	—	—	NLGI No. 2 (Lithium soap base)
Air conditioning system refrigerant	—	—	—	HFC-134a (R-134a)*9
Air conditioning system lubricants	—	—	—	NISSAN A/C System Oil Type S or exact equivalent
Windshield washer fluid	—	—	—	Genuine Nissan Windshield Washer Concentrate Cleaner & Antifreeze Fluid or equivalent

\*1: For additional information, see later in this section for fuel recommendation.

\*2: For additional information, see later in this section for engine oil and oil filter recommendation.

\*3: For additional information, see later in this section for recommended SAE viscosity number.

\*4: Using automatic transmission fluid other than Genuine Nissan Matic J ATF will cause deterioration in driveability and automatic transmission durability, and may damage the automatic transmission, which is not covered by the INFINITI new vehicle limited warranty.

\*5: For hot climates, viscosity SAE 90 is suitable for ambient temperatures always above 0°C (32°F).

\*6: DEXRON<sup>TM</sup>III/MERCON<sup>TM</sup> or equivalent may also be used. Outside the continental United States and Alaska contact an INFINITI dealer for more information regarding suitable fluids, including recommended brand(s) of DEXRON<sup>TM</sup>III/MERCON<sup>TM</sup> automatic transmission fluid.

\*7: Available in mainland US through your INFINITI dealer.

\*8: For additional information, see “Engine oil” in the “8. Maintenance and do-it-yourself” section for changing engine oil.

\*9: For additional information, see “Vehicle identification” in this section for air conditioner specification label.

\*10: For Canada, Nissan Automatic Transmission Fluid (ATF), DEXRON<sup>TM</sup>III/MERCON<sup>TM</sup> or equivalent ATF may also be used.

## 9-2 Technical and consumer information

## FUEL RECOMMENDATION

### Sedan models

Use unleaded regular gasoline with an octane rating of at least 87 AKI (Anti-Knock Index) number (Research octane number 91).

For improved vehicle performance, INFINITI recommends the use of unleaded premium gasoline with an octane rating of at least 91 AKI number (Research octane number 96).

### Coupe models

Use unleaded premium gasoline with an octane rating of at least 91 AKI (Anti-Knock Index) number (Research octane number 96).

If premium gasoline is not available, unleaded regular gasoline with an octane rating of 87 AKI number (Research octane number 91) may be temporarily used, but only under the following precautions:

- Have the fuel tank filled only partially with unleaded regular gasoline, and fill up with unleaded premium gasoline as soon as possible.
- Avoid full throttle driving and abrupt acceleration.

**However, for maximum vehicle performance, the use of unleaded premium gaso-**

line is recommended.



### CAUTION

**Using a fuel other than that specified could adversely affect the emission control devices and systems, and could also affect the warranty coverage.**

**Under no circumstances should a leaded gasoline be used, since this will damage the three-way catalyst.**

### Reformulated gasoline

Some fuel suppliers are now producing reformulated gasolines. These gasolines are specially designed to reduce vehicle emissions. INFINITI supports efforts towards cleaner air and suggests that you use reformulated gasoline when available.

### Gasoline containing oxygenates

Some fuel suppliers sell gasoline containing oxygenates such as ethanol, MTBE and methanol with or without advertising their presence. INFINITI does not recommend the use of fuels of which the oxygenate content and the fuel compatibility for your INFINITI cannot be readily determined. If in doubt, ask your

service station manager.

If you use oxygenate-blend gasoline, please take the following precautions as the usage of such fuels may cause vehicle performance problems and/or fuel system damage.

- **The fuel must be unleaded and have an octane rating no lower than that recommended for unleaded gasoline.**
- **If an oxygenate-blend, excepting a methanol blend, is used, it should contain no more than 10% oxygenate. (MTBE may, however, be added up to 15%.)**
- **If a methanol blend is used, it should contain no more than 5% methanol (methyl alcohol, wood alcohol). It should also contain a suitable amount of appropriate cosolvents and corrosion inhibitors. If not properly formulated with appropriate cosolvents and corrosion inhibitors, such methanol blends may cause fuel system damage and/or vehicle performance problems. At this time, sufficient data is not available to ensure that all methanol blends are suitable for use in INFINITI vehicles.**

If any driveability problems such as engine stalling and hard hot starting are experienced

after using oxygenate-blend fuels, immediately change to a non-oxygenate fuel or a fuel with a low blend of MTBE.

**Take care not to spill gasoline during refueling. Gasoline containing oxygenates can cause paint damage.**

### Aftermarket fuel additives

INFINITI does not recommend the use of any aftermarket fuel additives (i.e. fuel injector cleaner, octane booster, intake valve deposit removers, etc.) which are sold commercially. Many of these additives intended for gum, varnish or deposit removal may contain active solvent or similar ingredients that can be harmful to the fuel system and engine.

### Octane rating tips

In most parts of North America, you should use unleaded gasoline with an octane rating of at least 87 or 91 AKI (Anti-Knock Index) number. However, you may use unleaded gasoline with an octane rating as low as 85 AKI number in these high altitude areas [over 4,000 ft (1,219 m)] such as: Colorado, Montana, New Mexico, Utah, Wyoming, northeastern Nevada, southern Idaho, western South Dakota, western Nebraska, and that part of Texas which is directly south of New Mexico.

### 9-4 Technical and consumer information

**Using unleaded gasoline with an octane rating lower than stated above can cause persistent, heavy spark knock. (Spark knock is a metallic rapping noise.) If severe, this can lead to engine damage. If you detect a persistent heavy spark knock even when using gasoline of the stated octane rating, or if you hear steady spark knock while holding a steady speed on level roads, have your dealer correct the condition. Failure to correct the condition is misuse of the vehicle, for which INFINITI is not responsible.**

Incorrect ignition timing will result in knocking, after-run or overheating. This in turn may cause excessive fuel consumption or damage to the engine. If any of the above symptoms are encountered, have your vehicle checked at an INFINITI dealer or other competent service facility.

**However, now and then you may notice light spark knock for a short time while accelerating or driving up hills. This is no cause for concern, because you get the greatest fuel benefit when there is light spark knock for a short time under heavy engine load.**

API certification mark



API service symbol

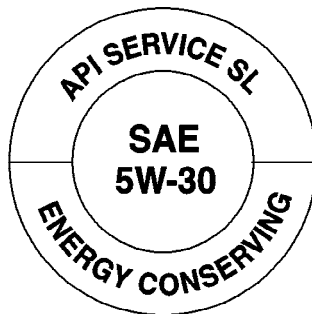

STI0367

## ENGINE OIL AND OIL FILTER RECOMMENDATION

### Selecting the correct oil

It is essential to choose the correct quality, and viscosity oil to ensure satisfactory engine life and performance. INFINITI recommends the use of a low friction oil (energy conserving oil) in order to improve fuel economy and conserve energy. Oils which do not have the specified quality label should not be used as they could cause engine damage.

Only those engine oils with the American Petroleum Institute (API) certification mark on the

front of the container should be used. This type of oil supersedes the existing API SG, SH, or SJ and Energy Conserving I & II categories.

If you cannot find engine oil with the API certification mark, use an API grade SG/SH, Energy Conserving I & II or API grade SJ or SL, Energy conserving oil. An oil with a single designation SG or SH, or in combination with other categories (for example, SG/CC or SG/CD) may also be used if one with the API certification mark cannot be found. An ILSAC grade GF-I, GF-II, GF-III oil can also be used.

INFINITI recommends mineral based oils. These oils must however, meet the API quality

and SAE viscosity ratings specified for your vehicle.

### Oil additives

INFINITI does not recommend the use of oil additives. The use of an oil additive is not necessary when the proper oil type is used and maintenance intervals are followed.

Oil which may contain foreign matter or has been previously used should not be used.

### Oil viscosity

The engine oil viscosity or thickness changes with temperature. Because of this, it is important that the engine oil viscosity be selected based on the temperatures at which the vehicle will be operated before the next oil change. The recommended SAE viscosity number chart shows the recommended oil viscosities for the expected ambient temperatures. Choosing an oil viscosity other than that recommended could cause serious engine damage.

### Selecting the correct oil filter

Your new vehicle is equipped with a high-quality genuine NISSAN oil filter. When replacing, use the genuine oil filter or its equivalent for the reason described in change intervals.

## Change intervals

The oil and oil filter change intervals for your engine are based on the use of the specified quality oils and filters. Oil and filter other than the specified quality, or oil and filter change intervals longer than recommended could reduce engine life. Damage to engines caused by improper maintenance or use of incorrect oil and filter quality and/or viscosity is not covered by the new INFINITI vehicle warranties.

Your engine was filled with a high quality engine oil when it was built. You do not have to change the oil before the first recommended change interval. Oil and filter change intervals depend upon how you use your vehicle. Operation under the following conditions may require more frequent oil and filter changes.

- repeated short distance driving at cold outside temperatures,
- driving in dusty conditions,
- extensive idling,
- towing a trailer,
- stop and go “rush hour” traffic.
- aggressive driving

## 9-6 Technical and consumer information

## RECOMMENDED SAE VISCOSITY NUMBER

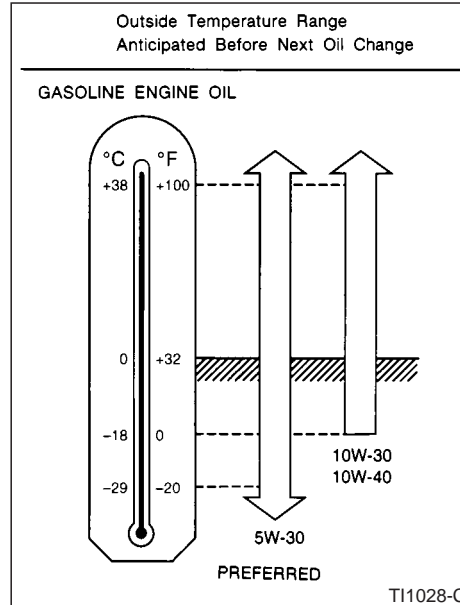

**SAE 5W-30 viscosity oil is preferred for all ambient temperatures. SAE 10W-30, 10W-40 viscosity oil may be used if the ambient temperature is above 0°F (-18°C).**

## AIR CONDITIONING SYSTEM REFRIGERANT AND LUBRICANT RECOMMENDATIONS

The air conditioning system in this INFINITI vehicle must be charged with the refrigerant HFC-134a (R-134a) and the lubricant, Nissan A/C System Oil Type S or the exact equivalents.



## CAUTION

The use of any other refrigerant or lubricant will cause severe damage to the air conditioning system and will require the replacement of all air conditioner system components.

The refrigerant HFC-134a (R-134a) in your INFINITI vehicle will not harm the earth's ozone layer. Although this refrigerant does not affect the earth's atmosphere, certain governmental regulations require the recovery and recycling of any refrigerant during automotive air conditioning system service. Your INFINITI dealer has the trained technicians and equipment needed to recover and recycle your air conditioning system refrigerant.

Contact your INFINITI dealer when servicing your air conditioning system.



## SPECIFICATIONS

### ENGINE

	Model	VQ35DE
Type		Gasoline, 4-cycle
Cylinder arrangement		6-cylinder, V-slanted at 60°
Bore x Stroke	in (mm)	3.760 x 3.205 (95.5 x 81.4)
Displacement	cu in (cm <sup>3</sup> )	213.45 (3,498)
Firing order		1-2-3-4-5-6*
Idle speed	rpm	
Ignition timing (B.T.D.C.)	degree/rpm	See the emission control label on the underside of the hood.
CO percentage at idle speed	[No air] %	
Spark plug	Standard	PLFR5A-11
	Service option	PLFR4A-11, PLFR6A-11
Spark plug gap (Normal)	in (mm)	0.043 (1.1)
Camshaft operation		Timing chain

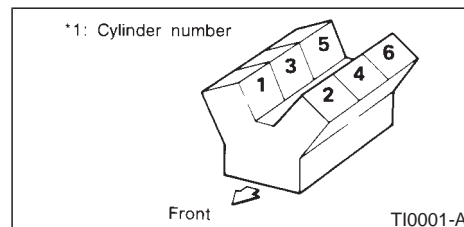

**The spark ignition system of this vehicle meets all requirements of the Canadian Interference-Causing Equipment Regulations.**

## WHEELS AND TIRES

### Road wheel

	Type	Position	Size	Offset in (mm)
Sedan	Aluminum	—	17 x 7JJ	1.75 (45)
Coupe	Aluminum	Front	17 x 7-1/2JJ	1.18 (30)
			18 x 8JJ	1.18 (30)
		Rear	17 x 8JJ	1.30 (33)
			18 x 8JJ	1.18 (30)

### Tire

	Type	Position	Size	Pressure (Cold)
Sedan	Conventional	—	P215/55R17 93V/W	30 psi (210 kPa)
	Spare	—	T145/90D16	60 psi (420 kPa)
Conventional*			—	
Coupe	Conventional	Front	P225/50R17 93V	30 psi (210 kPa)
		Rear	P235/50R17 95V	30 psi (210 kPa)
		Front	225/45R18 91W	35 psi (240 kPa)
		Rear	245/45R18 96W	35 psi (240 kPa)
	Spare	—	T145/90D16	60 psi (420 kPa)
			T155/80R17*	60 psi (420 kPa)
	Conventional*		—	

\*: For option

## DIMENSIONS AND WEIGHTS

		Sedan	Coupe
Overall length	in (mm)	186.5 (4,736)	182.2 (4,628)
Overall width	in (mm)	69.0 (1,753)	71.5 (1,815)
Overall height	in (mm)	57.7 (1,467)	54.8 (1,393)
Front tread	in (mm)	59.1 (1,500)*1	60.4 (1,535)
Rear tread	in (mm)	59.3 (1,505)*1	60.6 (1,540)*2 60.8 (1,545)*3
Wheelbase	in (mm)	112.2 (2,850)	←
Gross vehicle weight rating	lb (kg)	See the F.M.V.S.S. certification label on the driver's side lock pillar.	
Gross axle weight rating			
Front	lb (kg)		
Rear	lb (kg)		

\*1: For models with road wheel size — 17 x 7JJ [offset 1.75 in (45 mm)]

\*2: For models with road wheel size — 17 x 8JJ [offset 1.30 in (33 mm)]

\*3: For models with road wheel size — 18 x 8JJ [offset 1.18 in (30 mm)]

## WHEN TRAVELING OR REGISTERING YOUR VEHICLE IN ANOTHER COUNTRY

**When planning to travel in another country,** you should first find out if the fuel available is suitable for your vehicle's engine.

Using fuel with too low an octane rating may cause engine damage. All gasoline vehicles must be operated with unleaded engine gasoline. Therefore, avoid taking your vehicle to areas where appropriate fuel is not available.

**When transferring the registration of your vehicle to another country, state, province or district,** it may be necessary to modify the vehicle to meet local laws and regulations.

The laws and regulations for motor vehicle emission control and safety standards vary according to the country, state, province or district; therefore, vehicle specifications may differ.

**When any vehicle is to be taken into another country, state, province or district and registered, its modifications, transportation, and registration are the responsibility of the user. INFINITI is not responsible for any inconvenience that may result.**

## VEHICLE IDENTIFICATION

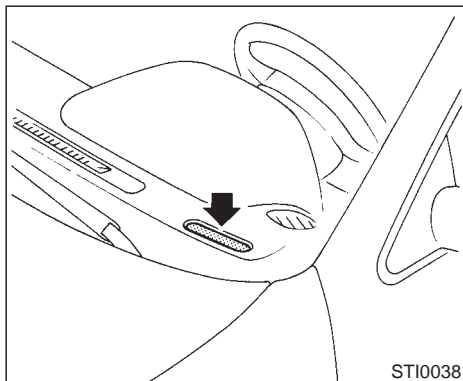

### VEHICLE IDENTIFICATION NUMBER (VIN) PLATE

The vehicle identification number plate is attached as shown. This number is the identification for your vehicle and is used in the vehicle registration.

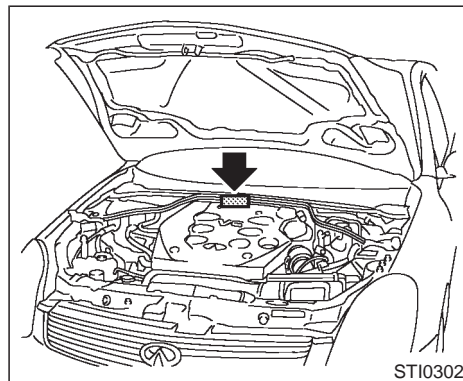

### VEHICLE IDENTIFICATION NUMBER (Chassis number)

The number is stamped as shown.

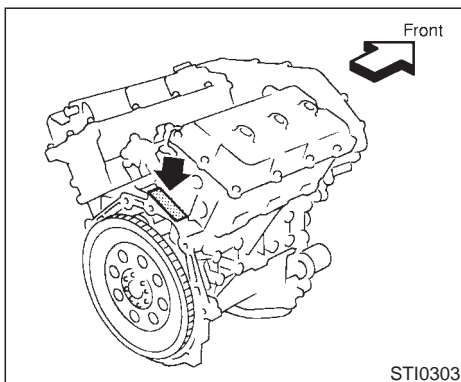

## ENGINE SERIAL NUMBER

The number is stamped on the engine as shown.

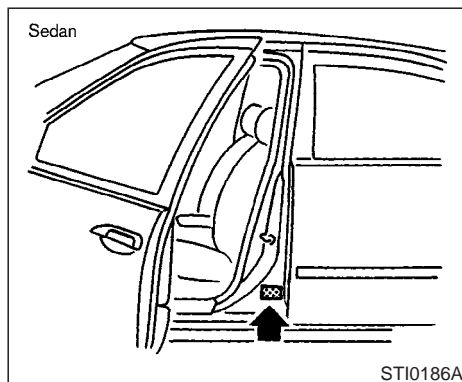

## F.M.V.S.S. CERTIFICATION LABEL

The Federal Motor Vehicle Safety Standards (F.M.V.S.S.) certification label is affixed as shown. This label contains valuable vehicle information, such as: Gross Vehicle Weight Ratings (GVWR), Gross Axle Weight Rating (GAWR), month and year of manufacture, Vehicle Identification Number, (VIN), etc. Review it carefully.

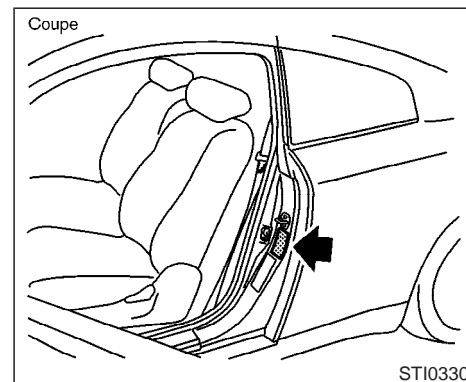

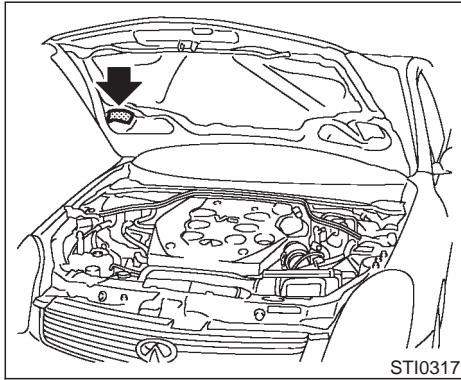

## EMISSION CONTROL INFORMATION LABEL

The emission control information label is attached as shown.

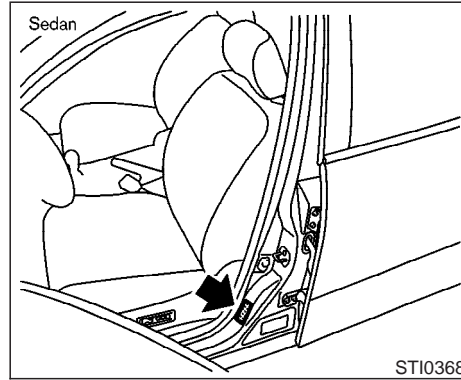

## TIRE AND LOADING INFORMATION LABEL

The cold tire pressures are shown on the Tire and Loading Information label affixed to the driver side center pillar.

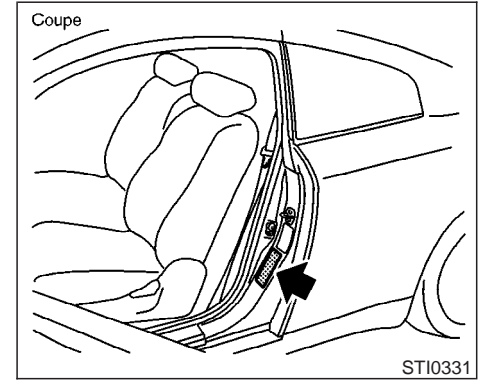

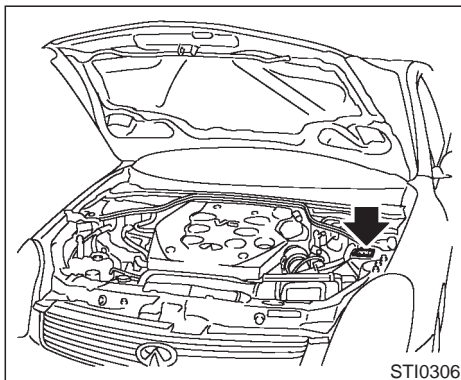

### AIR CONDITIONER SPECIFICATION LABEL

The air conditioner specification label is affixed inside of the hood as shown.

### INSTALLING FRONT BUMPER COVER

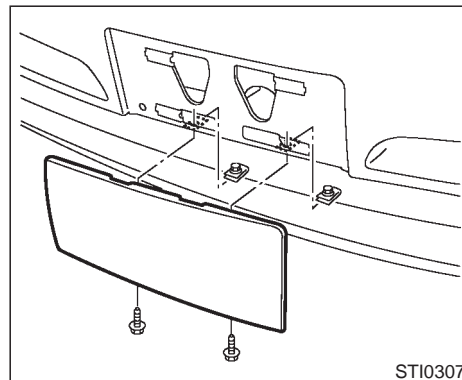

Use the following steps to mount the bumper cover:

Before mounting the bumper cover, confirm that the following parts are enclosed in the vinyl bag.

- Front bumper cover
- J-nut x 2
- Screw x 2

1. Temporarily place the bumper cover and mark on the J-nut inserting place.
2. Remove the bumper cover.

3. Insert a J-nut into the backside of the bumper fascia.

4. Install the bumper cover with screws.

## INSTALLING FRONT LICENSE PLATE

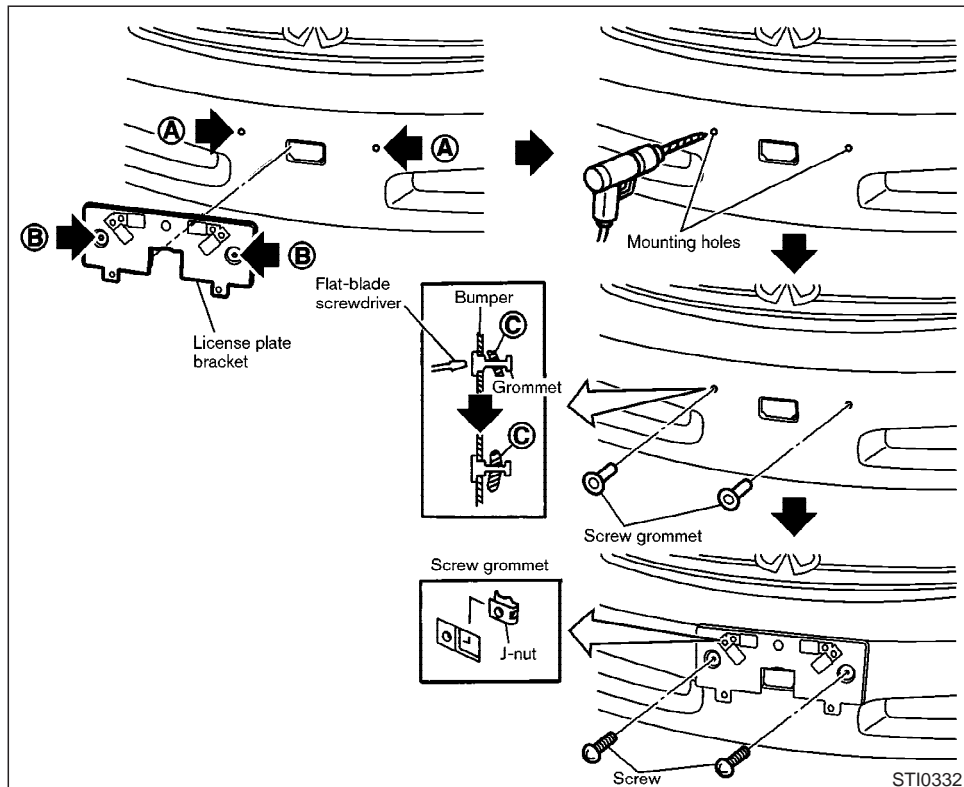

Use the following steps to mount the license plate:

Before mounting the license plate, confirm that the following parts are enclosed in the vinyl bag.

- License plate bracket
- J-nut x 2
- Screw x 2
- Screw grommet x 2

1. Temporarily place the license plate bracket and mark the pilot hole points (A) using holes (B) while aligning the towing hook hole of the front bumper fascia.
2. Remove the license plate bracket.
3. Carefully drill two pilot holes (A) using a 0.39 in (10 mm) drill bit at the marked locations. **(Be sure that the drill only goes through the fascia, or damage to the nut may occur.)**
4. Insert grommets into the hole on the fascia.
5. Insert a flat-blade screwdriver into the grommet hole to turn part (C) 90 degrees.
6. Insert a J-nut into the license plate bracket before placing the license plate bracket on the fascia.

7. Install the license plate bracket with screws.
8. Install the license plate with bolts that are no longer than 0.55 in (14 mm).

## VEHICLE LOADING INFORMATION



### WARNING

- **It is extremely dangerous to ride in a cargo area inside of a vehicle. In a collision, people riding in these areas are more likely to be seriously injured or killed**
- **Do not allow people to ride in any area of your vehicle that is not equipped with seats and seat belts.**
- **Be sure everyone in your vehicle is in a seat and using a seat belt properly.**

## TERMS

It is important to familiarize yourself with the following terms before loading your vehicle:

- **Curb Weight** (actual weight of your vehicle) - vehicle weight including: standard and optional equipment, fluids, emergency tools, and spare tire assembly. This weight **does not** include passengers and cargo.
- **GVW** (Gross Vehicle Weight) - curb weight plus the combined weight of passengers and cargo.

- **GVWR** (Gross Vehicle Weight Rating) - maximum total combined weight of the unloaded vehicle, passengers, luggage, hitch, trailer tongue load and any other optional equipment. This information is located on the F.M.V.S.S. label.
- **GAWR** (Gross Axle Weight Rating) - maximum weight (load) limit specified for the front or rear axle. This information is located on the F.M.V.S.S. label.
- **GCWR** (Gross Combined Weight Rating) - The maximum total weight rating of the vehicle, passengers, cargo, and trailer.
- **Vehicle Capacity Weight, Load limit, Total load capacity** - maximum total weight limit specified of the load (passengers and cargo) for the vehicle. This is the maximum combined weight of occupants and cargo that can be loaded into the vehicle. If the vehicle is used to tow a trailer, the trailer tongue weight must be included as part of the cargo load. This information is located on the Tire and Loading Information label.
- **Cargo capacity** - permissible weight of cargo, the subtracted weight of occupants from the load limit.



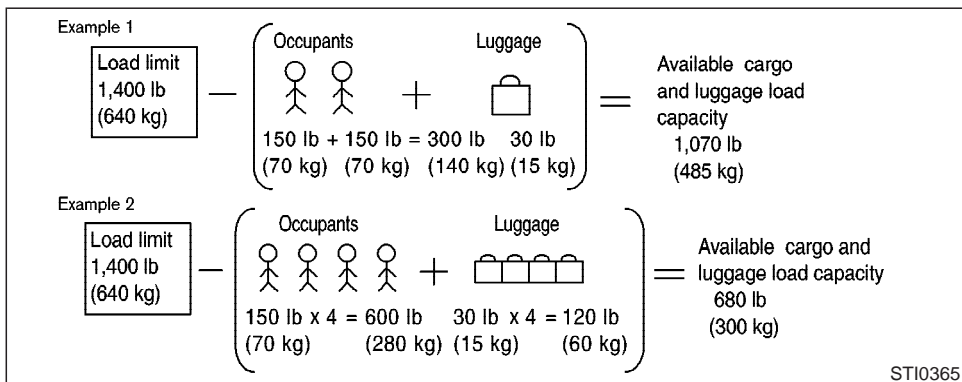

## VEHICLE LOAD CAPACITY

Do not exceed the load limit of your vehicle shown as “The combined weight of occupants and cargo” on the Tire and Loading Information label. Do not exceed the number of occupants shown as “Seating Capacity” on the Tire and Loading Information label.

To get “the combined weight of occupants and cargo”, add the weight of all occupants, then add the total luggage weight to the value. Examples are shown in the illustration.

## Steps for determining correct load limit

- (1) Locate the statement “The combined weight of occupants and cargo should never exceed XXX kilograms or XXX pounds” on your vehicle’s placard.
- (2) Determine the combined weight of the driver and passengers that will be riding in your vehicle.
- (3) Subtract the combined weight of the driver and passengers from XXX kilograms or XXX pounds.

(4) The resulting figure equals the available amount of cargo and luggage load capacity. For example, if the “XXX” amount equals 1,400 lbs. and there will be five 150 lb. passengers in your vehicle, the amount of available cargo and luggage load capacity is 650 lbs. [1,400 – 750 (5 x 150) = 650 lbs.]

(5) Determine the combined weight of luggage and cargo being loaded on the vehicle. For safety, that weight must not exceed the available cargo and luggage load capacity calculated in Step 4.

(6) If your vehicle will be towing a trailer, load from your trailer will be transferred to your vehicle. Consult this manual to determine how this reduces the available cargo and luggage load capacity of your vehicle.

## LOADING TIPS

- The GVW must not exceed GVWR or GAWR as specified on the F.M.V.S.S. certification label.
- Do not load the front and rear axle to the GAWR. Doing so will exceed the GVWR.



## WARNING

- Properly secure all cargo to help prevent it from sliding or shifting. Do not place cargo higher than the seat-backs. In a sudden stop or collision, unsecured cargo could cause personal injury.
- Do not load your vehicle any heavier than the GVWR or the maximum front and rear GAWRs. If you do, parts on your vehicle can break, or it can change the way your vehicle handles. This could result in loss of control and cause personal injury.
- Overloading not only could shorten the life of your vehicle and the tires, but also could lead to hazardous vehicle handling and long braking distance. This may cause a premature tire malfunction, which could result in a serious accident and personal injury. Failures caused by overloading are not covered by your warranty.

## TOWING A TRAILER

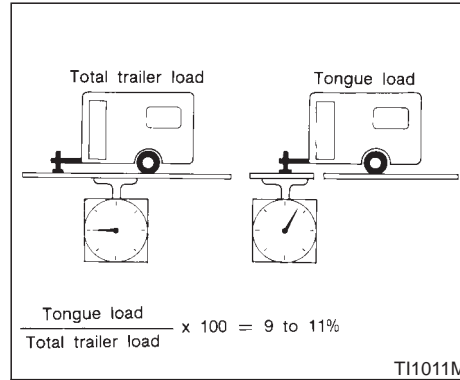

Your new vehicle was designed to be used primarily to carry passengers and cargo. Remember that towing a trailer will place additional loads on your vehicle's engine, drive train, steering, braking and other systems.

An **INFINITI Trailer Towing Guide (US only)** is available from an authorized INFINITI dealer. This guide includes information on trailer towing ability and the special equipment required for proper towing.

## MAXIMUM LOAD LIMITS

### Maximum trailer loads

Never allow the total trailer load to exceed the value specified in the Towing Load/Specification Chart found later in this section. The total trailer load equals trailer weight plus its cargo weight.

Towing loads greater than specified or using improper towing equipment could adversely affect vehicle handling, braking and performance. The ability of your vehicle to tow a trailer is not only related to the maximum trailer loads, but also the places you plan to tow. Tow weights appropriate for level highway driving may have to be reduced on very steep grades or in low traction situations (for example, on slippery boat ramps).



## CAUTION

Vehicle damage resulting from improper towing procedures are not covered by INFINITI warranties. An INFINITI Trailer Towing Guide (U.S. only) containing information on trailer towing ability and the special equipment required may be obtained from an authorized INFINITI dealer.

### Tongue load

Keep the tongue load between 9 and 11% of the total trailer load within the maximum tongue load limits shown in the following Towing Load/Specification Chart. If the tongue load becomes excessive, rearrange cargo to allow for proper tongue load.

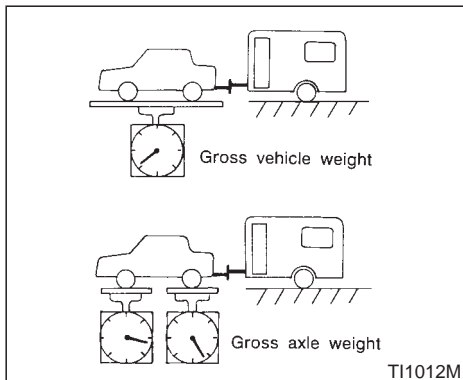

### Maximum gross vehicle weight/ maximum gross axle weight

The gross vehicle weight of the towing vehicle must not exceed the gross vehicle weight rating (GVWR) shown on the F.M.V.S.S. certification label. The gross vehicle weight equals the combined weight of the unloaded vehicle, passengers, luggage, hitch, trailer tongue load and any other optional equipment. In addition, front or rear gross axle weight must not exceed GAWR shown on the F.M.V.S.S. certification label.

## TOWING LOAD/SPECIFICATION

TOWING LOAD/SPECIFICATION CHART	
Unit: lb (kg)	
MAXIMUM TOWING LOAD	1,000 (454)
MAXIMUM TONGUE LOAD	110 (49)

## TOWING SAFETY

### Trailer hitch

Choose a proper hitch for your vehicle and trailer. Make sure the trailer hitch is securely attached to the vehicle, to help avoid personal injury or property damage due to sway caused by crosswinds, rough road surfaces or passing trucks.



## CAUTION

- Do not use axle-mounted hitches.
- The hitch should not be attached to or affect the operation of the impact-absorbing bumper.
- Do not modify the vehicle exhaust system, brake system, etc. to install a trailer hitch.
- To reduce the possibility of additional damage if your vehicle is struck from the rear, where practical, remove the hitch and/or receiver when not in use.
- After the hitch is removed, seal the bolt holes to prevent exhaust fumes, water or dust from entering the passenger compartment.
- Regularly check that all hitch mounting bolts are securely mounted.

### Tire pressures

- When towing a trailer, inflate the vehicle tires to the recommended cold tire pressure indicated on the Tire and Loading Informa-

tion label (located on the driver side center pillar).

- Trailer tire condition, size, load rating and proper inflation pressure should be in accordance with the trailer and tire manufacturers' specifications.

### Safety chain

Always use a suitable chains between your vehicle and the trailer. The safety chains should be crossed and should be attached to the hitch, not to the vehicle bumper or axle. Be sure to leave enough slack in the chains to permit turning corners.

### Trailer lights

Trailer lights should comply with federal and/or local regulations. When wiring the vehicle for towing, connect the stop and tail light pickup into the vehicle electrical circuit.

### Trailer brakes

If your trailer is equipped with a braking system, make sure it conforms to federal and/or local regulations and that it is properly installed.



## WARNING

**Never connect a trailer brake system directly to the vehicle brake system.**

### Pre-towing tips

- Be certain your vehicle maintains a level position when a loaded and/or unloaded trailer is hitched. Do not drive the vehicle if it has an abnormal nose-up or nose-down condition; check for improper tongue load, overload, worn suspension or other possible causes of either condition.
- Always secure items in the trailer to prevent load shifts while driving.
- Be certain your rear view mirrors conform to all federal, state or local regulations. If not, install any mirrors required for towing before driving the vehicle.

### Trailer towing tips

In order to gain skill and an understanding of the vehicle's behavior, you should practice turning, stopping and backing up in an area which is free from traffic. Steering stability, and braking performance will be somewhat different than under normal driving conditions.

- Always secure items in the trailer to prevent load shift while driving.
- Avoid abrupt starts, acceleration or stops.
- Avoid sharp turns or lane changes.
- Always drive your vehicle at a moderate speed.
- Always block the wheels on both vehicle and trailer when parking. Parking on a slope is not recommended; however, if you must do so, and if your vehicle is equipped with automatic transmission, first apply the parking brake and block the wheels, and then move the transmission selector lever into the P (Park) position. If you move the selector lever to the P (Park) position before applying the parking brake and blocking the wheels, transmission damage could occur.
- When going down a hill, shift into a lower gear and use the engine braking effect. When going up a long grade, downshift the transmission to a lower gear and reduce speed to reduce chances of engine overloading and/or overheating. However, for long steep grades, do not stay in 1st or 2nd gear when driving above 35 MPH (56 km/h).
- If the engine coolant rises to an extremely

high temperature when the air conditioning system is on, turn off the air conditioner. Coolant heat can be additionally vented by opening the windows, switching the fan control to high and setting the temperature control to the HOT position.

- Trailer towing requires more fuel than normal circumstances.
- Avoid towing a trailer for the first 500 miles (800 km).
- Have your vehicle serviced more often than at intervals specified in the recommended maintenance schedule in the INFINITI Service and Maintenance Guide.
- When making a turn, your trailer wheels will be closer to the inside of the turn than your vehicle wheels. To compensate for this, make a larger than normal turning radius during the turn.
- Crosswinds and rough roads will adversely affect vehicle/trailer handling, possibly causing vehicle sway. When being passed by larger vehicles, be prepared for possible changes in crosswinds that could affect vehicle handling. If swaying does occur, firmly grip the steering wheel, steer straight ahead, and immediately (but gradually) reduce vehicle speed. This combination will

help stabilize the vehicle. Never increase speed.

- Be careful when passing other vehicles. Passing while towing a trailer requires considerably more distance than normal passing. Remember the length of the trailer must also pass the other vehicle before you can safely change lanes.
- To maintain engine braking efficiency and electrical charging performance, do not use sixth gear (manual transmission) or fifth position (automatic transmission).
- Avoid holding the brake pedal down too long or too frequently. This could cause the brakes to overheat, resulting in reduced braking efficiency.

**When towing a trailer, transmission oil/fluid should be changed more frequently.**

**For additional information, see the “8. Maintenance and do-it-yourself” section earlier in this manual.**

## FLAT TOWING

Towing your vehicle with all four wheels on the ground is sometimes called flat towing. This method is sometimes used when towing a vehicle behind a recreational vehicle, such as a motor home.



## CAUTION

- Failure to follow these guidelines can result in severe transmission damage.
- Whenever flat towing your vehicle, always tow forward, never backward.
- DO NOT tow any automatic transmission vehicle with all four wheels on the ground (flat towing). Doing so WILL DAMAGE internal transmission parts due to lack of transmission lubrication.
- For emergency towing procedures refer to “Towing Recommended by INFINITI” in the “In case of emergency” section of this manual.

### Automatic transmission

To tow a vehicle equipped with an automatic transmission, an appropriate vehicle dolly **MUST** be placed under the towed vehicle's drive wheels. **Always** follow the dolly manufacturer's recommendations when using their product.

9-20 Technical and consumer information

### Manual transmission

- Always tow with the manual transmission in Neutral.
- After towing 500 miles, start and idle the engine with the transmission in Neutral for two minutes. Failure to idle the engine after every 500 miles of towing may cause damage to the transmission's internal parts.

## UNIFORM TIRE QUALITY GRADING

DOT (Department Of Transportation) Quality Grades: All passenger car tires must conform to federal safety requirements in addition to these grades.

Quality grades can be found where applicable on the tire sidewall between tread shoulder and maximum section width. For example:

Treadwear 200 Traction AA Temperature A

### Treadwear

Treadwear grade is a comparative rating based on tire wear rate when tested under controlled conditions on specified government test courses. For example, a tire graded 150 would wear one and a half (1-1/2) times as well on the government course as a tire graded 100. However, relative tire performance depends on actual driving conditions, and may vary significantly from the norm due to variations in driving habits, service practices and differences in road characteristics and climate.

### Traction AA, A, B and C

The traction grades, from highest to lowest, are AA, A, B, and C. Those grades represent the tire's ability to stop on wet pavement as measured under controlled conditions on specified government test surfaces of asphalt

and concrete. A tire marked C may have poor traction performance.



## WARNING

The traction grade assigned to your vehicle tires is based on straight-ahead braking traction tests, and does not include acceleration, cornering, hydroplaning, or peak traction characteristics.

### Temperature A, B and C

Temperature grades are A (the highest), B, and C. They represent a tire's resistance to heat build-up, and its ability to dissipate heat when tested under controlled conditions on a specified indoor laboratory test wheel. Sustained high temperature can cause tire material to degenerate, reducing tire life. Excessive temperatures can lead to sudden tire failure. Grade C corresponds to a performance level which all passenger car tires must meet under the Federal Motor Vehicle Safety Standard No. 109. Grades A and B represent higher levels of performance on laboratory test wheels than the minimum required by law.



## WARNING

The temperature grade for this tire is established for a tire that is properly inflated and not overloaded. Excessive speed, underinflation, or excessive loading, either separately or in combination, can cause heat buildup and possible tire failure.

## EMISSION CONTROL SYSTEM WARRANTY

Your INFINITI is covered by the following emission warranties.

### For US:

- Emission Defects Warranty
- Emissions Performance Warranty (See Warranty Information Booklet for details.)

### For Canada:

Emission Control System Warranty

Details of these warranties may be found with other vehicle warranties in your Warranty Information Booklet (Warranty and Roadside Assistance Information (Canada only)) that comes with your INFINITI. If you did not receive a Warranty Information Booklet (Warranty and Roadside Assistance Information (Canada only)), or it has become lost, you may obtain a replacement by writing to:

- INFINITI Division  
Nissan North America, Inc.  
Consumer Affairs Department  
P.O. Box 47038, Gardena, CA 90247-6838
- Nissan Canada Inc.  
5290 Orbitor Drive  
Mississauga, Ontario, L4W 4Z5

- INFINITI Division  
Nissan Motor Corporation in Hawaii, Ltd.  
Consumer Affairs Department  
2880 Kilihau Street  
Honolulu, Hawaii 96819

## REPORTING SAFETY DEFECTS (US only)

If you believe that your vehicle has a defect which could cause a crash or could cause injury or death, you should immediately inform the National Highway Traffic Safety Administration (NHTSA) in addition to notifying INFINITI.

If NHTSA receives similar complaints, it may open an investigation, and if it finds that a safety defect exists in a group of vehicles, it may order a recall and remedy campaign. However, NHTSA cannot become involved in individual problems between you, your retailer, or INFINITI.

To contact NHTSA, you may call the Auto Safety Hotline toll-free at 1-888-327-4236. You may also write to: NHTSA, U.S. Department of Transportation, Washington, D.C. 20590. You can also obtain other information about motor vehicle safety from the Hotline.

You may notify INFINITI by contacting our Consumer Affairs Department, toll-free, at 1-800-662-6200.  
In Hawaii call (808) 836-0888.

## READINESS FOR INSPECTION/ MAINTENANCE (I/M) TEST (US only)

A vehicle equipped with All-Wheel Drive (AWD) should never be tested using a two wheel dynamometer (such as the dynamometers used by some states for emissions testing), or similar equipment. Make sure you inform test facility personnel that your vehicle is equipped with AWD before it is placed on a dynamometer. Using the wrong test equipment may result in transmission damage or unexpected vehicle movement which could result in serious vehicle damage or personal injury.

Due to legal requirements in some states/areas, your vehicle may be required to be in what is called the “ready condition” for an Inspection/Maintenance (I/M) test of the emission control system.

The vehicle is set to the “ready condition” when it is driven through certain driving patterns. Usually, the “ready condition” can be obtained by ordinary usage of the vehicle.

If a powertrain system component is repaired or the battery is disconnected, the vehicle may be reset to a not “ready condition”. Before taking the I/M test, drive the vehicle through the following pattern to set the vehicle to the ready condition. If you cannot or do not want to perform the driving pattern, an INFINITI dealer can conduct it for you.





## WARNING

**Always drive the vehicle in a safe and prudent manner according to traffic conditions, and obey all traffic laws.**

1. Start the engine. Allow the engine to idle until the engine coolant temperature gauge needle points between the C and H (normal operating temperature).
  2. Accelerate the vehicle to 55 MPH (88 km/h), then quickly release the accelerator pedal completely and keep it released for at least 6 seconds.
  3. Quickly depress the accelerator pedal for a moment, then drive the vehicle at a speed of 53 to 60 MPH (86 to 96 km/h) for at least 5 minutes.
  4. Stop the vehicle. Leave the engine running.
  5. Accelerate the vehicle to 35 MPH (55 km/h) and maintain the speed for 20 seconds.
  6. Repeat steps 4 and 5 at least 3 times.
  7. Accelerate the vehicle to 55 MPH (88 km/h) and maintain the speed for at least 3 minutes.
  8. Stop the vehicle. Place the automatic transmission selector lever in the “P” or “N” position or the manual transmission shift lever in the “N” position.
9. Turn the engine off.
10. Repeat steps 1 through 8 at least one more time.
- If step 1 through 7 is interrupted, repeat the preceding step. Any safe driving mode is acceptable between steps. Do not stop the engine until step 7 is completed.

## EVENT DATA RECORDERS

Your vehicle is equipped with a variety of computers that monitor and control a number of systems to optimize performance and help service technicians with diagnosis and repair. Depending on the equipment on your vehicle, some of the computers monitor emission control systems, braking systems and air bag systems, just to name a few. Some data about vehicle operation may be stored in the computers for use during servicing. Other data may be stored if a crash event occurs. For example, air bag readiness, air bag performance, and seat belt use by the driver or passenger may be recorded, depending on vehicle equipment. These types of systems are sometimes called Event Data Recorders.

Special equipment can be used to access the electronic data that may be stored in the vehicle's computers (sounds are not recorded). INFINITI and dealers have equipment to access some of this data; others may also have this equipment. The data may be retrieved during routine vehicle servicing or for special research. It might also be accessed with the consent of the vehicle owner or lessee, in response to a request by law enforcement, or as otherwise required or permitted by law.

## OWNER'S MANUAL/SERVICE MANUAL ORDER INFORMATION

A genuine INFINITI Service Manual is the best source of service and repair information for your vehicle. Filled with wiring diagrams, illustrations and step-by-step diagnostic and adjustment procedures, this manual is the same one used by the factory trained technicians working at authorized INFINITI dealerships. Also available are genuine INFINITI Owner's Manuals, and genuine INFINITI Service and Owner's Manuals for older INFINITI models.

### In the USA:

For current pricing and availability of genuine **INFINITI Service Manuals** for the 2000 model year and later, contact:

Tweddle Litho Company  
1-800-450-9491  
www.nissan-techinfo.com

For current pricing and availability of genuine **INFINITI Service Manuals** for the 1999 model year and prior, see an authorized INFINITI dealer, or contact:

DDS Distribution Services, Ltd.  
20770 Westwood Road  
Strongsville, OH 44136  
1-800-247-5321

For current pricing and availability of genuine **INFINITI Owner's Manuals** for the 2004 model year and prior, see an authorized

9-24 **Technical and consumer information**

INFINITI dealer, or contact:

DDS Distribution Services, Ltd.  
20770 Westwood Road  
Strongsville, OH 44136  
1-800-247-5321

### In Canada:

To purchase a copy of a genuine INFINITI Service Manual or Owner's Manual please contact your nearest INFINITI dealer. For the phone number and location of an INFINITI dealer in your area call the INFINITI Satisfaction Center at 1-800-361-4792 and a bilingual INFINITI representative will assist you.

Also available are genuine INFINITI Service and Owner's Manuals for older INFINITI models.

## IN THE EVENT OF A COLLISION

Unfortunately, accidents do occur. In this unlikely event, there is some important information you should know. Many insurance companies routinely authorize the use of non-genuine collision parts in order to cut costs, among other reasons.

### Insist on the use of Genuine Infiniti Collision Parts!

If you want your vehicle to be restored using parts made to INFINITI's original exacting specifications — if you want to help it to last

and hold its resale value, the solution is simple. **Tell your insurance agent and your repair shop to only use Genuine Infiniti Collision Parts.** INFINITI does not warrant non-Infiniti parts, nor does Infiniti's warranty apply to damage caused by a non-genuine parts.

Using Genuine Infiniti Parts can help protect your personal safety, preserve your warranty protection and maintain the resale value of your vehicle. And if your vehicle was leased, using Genuine Infiniti Parts may prevent or limit unnecessary excess wear and tear expenses at the end of your lease.

INFINITI designs its hoods with crumple zones to minimize the risk that the hood will penetrate the windshield of your vehicle in an accident. Non-genuine (imitation) parts may not provide such built in safety features. Also, non-genuine parts often show premature wear, rust and corrosion.

### Why should you take a chance?

In over 40 states, the law says you must be advised if non-genuine parts are used to repair your vehicle. And some states/provinces have enacted laws that restrict insurance companies from authorizing the use of non-genuine collision parts during the new vehicle warranty. These laws help protect you, so you can take action to protect yourself.

**It's your right!**

# 10 Index

## A

ABS (Anti-lock brake system).....	5-23
Air bag system, Side and curtain (See supplemental side air bag and curtain side-impact air bag system).....	1-20
Air bag warning labels.....	1-23
Air bag warning light.....	1-23, 2-11
Air cleaner housing filter.....	8-19
Air conditioner	
Air conditioner operation.....	4-3
Air conditioner service.....	4-3, 4-6
Air conditioner specification label.....	9-12
Air conditioning system refrigerant and lubricant recommendations.....	4-6, 9-6
Heater and air conditioner (automatic).....	4-3
In-cabin microfilter.....	4-5
Alcohol, drugs and driving.....	5-5
Ambient temperature, Air conditioner.....	4-5
Anchor point locations	
Top tether strap.....	1-42
Antenna.....	4-17
Anti-lock Brake System (ABS).....	5-23
Anti-lock brake warning light.....	2-9
Appearance care	
Exterior appearance care.....	7-2
Interior appearance care.....	7-3
Armrest, Rear armrest pocket.....	2-32

Ashtrays (See cigarette lighter and ashtray).....	2-27
Audible reminders.....	2-14
Audio operation precautions.....	4-8
Audio system.....	4-6
Autochanger, Compact Disc (CD).....	4-15
Autolight system.....	2-20
Automatic	
Anti-glare inside mirror.....	3-16
Automatic adjusting function.....	2-36
Automatic sunroof.....	2-37
Automatic transmission fluid (ATF).....	8-13
Automatic transmission position indicator light.....	2-12
Drive positioner.....	3-17
Driving with automatic transmission....	5-6, 5-9
Seat positioner, seat.....	3-17
Transmission selector lever lock release.....	5-13
Avoiding collision and rollover.....	5-4
AWD (all wheel drive) warning light.....	2-10

## B

Battery.....	8-16
Battery saver system.....	2-21
Battery replacement	
Intelligent Key system.....	3-8
Remote keyless entry system.....	3-8

Before starting the engine.....	5-8
Belts (See drive belts).....	8-18
Brake	
Anti-lock brake system (ABS).....	5-23
Brake and clutch fluid.....	8-14
Brake booster.....	8-22
Brake fluid.....	8-14
Brake pedal.....	8-21
Brake pedal check.....	8-22
Brake system.....	5-22
Parking brake check.....	5-15, 8-21
Parking brake operation.....	5-15
Warning light.....	2-10
Break-in schedule.....	5-18
Brightness control, Instrument panel.....	2-21
Bulb check/instrument panel.....	2-9
Bulb replacement.....	8-26

## C

Cabin air filter.....	4-5
Capacities and recommended fuel/lubricants... ..	9-2
Car phone or CB radio.....	4-18
Card holder.....	2-33
Cassette player (See audio system).....	4-14
Catalytic converter, Three way catalyst.....	5-3
CD care and cleaning.....	4-16
Child restraints.....	1-33
Installation on front passenger seat.....	1-43

Installation on rear seat outboard or center position .....	1-35
Precautions on child restraints .....	1-33
Top tether strap anchor point locations ....	1-42
With top tether strap .....	1-41
Child safety .....	1-28
Child safety rear door lock .....	3-5
Chimes	
Audible reminders .....	2-14
Seat belt warning light and chime .....	2-11
Cigarette lighter and ashtray .....	2-27
Circuit breaker, Fusible link .....	8-24
Cleaning exterior and interior .....	7-2, 7-3
Clock .....	2-26
Clutch fluid .....	8-14
Coat hook .....	2-33
Cold weather driving .....	5-26
Compact Disc (CD) changer operation .....	4-15
Compass display .....	2-6
Console box .....	2-31
Controls, Heater and air conditioner controls (automatic) .....	4-3
Coolant	
Capacities and recommended fuel/lubricants .....	9-2
Changing engine coolant .....	8-9
Checking engine coolant level .....	8-8
Corrosion protection .....	7-5
Cruise control .....	5-16
Cup holder .....	2-29
Curtain side-impact air bag system (See supplemental side air bag and curtain side-impact air bag system) .....	1-20

CVT, Transmission selector lever lock release .....	5-13
---	------

## D

Daytime running light system .....	2-22
Defroster switch, Rear window and outside mirror defroster switch .....	2-18
Dimensions and weights .....	9-8
Door open warning light .....	2-11
Drive belts .....	8-18
Drive positioner, Automatic .....	3-17
Driving	
Cold weather driving .....	5-26
Driving with automatic transmission ....	5-6, 5-9
Driving with manual transmission .....	5-7, 5-14
Precautions when starting and driving .....	5-2

## E

Economy, Fuel .....	5-19
Emission control information label .....	9-11
Emission control system warranty .....	9-21
Engine	
Before starting the engine .....	5-8
Break-in schedule .....	5-18
Capacities and recommended fuel/lubricants .....	9-2
Changing engine coolant .....	8-9
Changing engine oil and filter .....	8-11
Checking engine coolant level .....	8-8
Checking engine oil level .....	8-10
Coolant temperature gauge .....	2-4
Engine block heater .....	5-27

Engine compartment check locations .....	8-7
Engine cooling system .....	8-8
Engine oil .....	8-10
Engine oil and oil filter recommendation .....	9-5
Engine oil viscosity .....	9-5
Engine serial number .....	9-10
Engine specifications .....	9-7
If your vehicle overheats .....	6-10
Starting the engine .....	5-9
Event data recorders .....	9-23
Exhaust gas (Carbon monoxide) .....	5-2

## F

F.M.V.S.S. certification label .....	9-10
Filter	
Air cleaner housing filter .....	8-19
Changing engine oil and filter .....	8-11
Flashers (See hazard warning flasher switch) .....	2-23
Flat tire .....	6-2
Flat tire, Low tire pressure warning system ....	5-3
Floor mat cleaning .....	7-4
Fluid	
Automatic transmission fluid (ATF) .....	8-13
Brake and clutch fluid .....	8-14
Brake fluid .....	8-14
Capacities and recommended fuel/lubricants .....	9-2
Engine coolant .....	8-8
Engine oil .....	8-10
Power steering fluid .....	8-13
Window washer fluid .....	8-15

FM-AM-SATELLITE radio with cassette player and compact disc (CD) changer .....	4-11
Fog light switch .....	2-22
Front manual seat adjustment .....	1-2
Front power seat adjustment .....	1-4
Fuel	
Capacities and recommended fuel/lubricants .....	9-2
filler cap .....	3-13
filler lid .....	3-12
Fuel economy .....	5-19
Fuel octane rating .....	9-3, 9-4
Fuel recommendation .....	9-3
Gauge .....	2-5
Fuses .....	8-23
Fusible links .....	8-24

## G

Garage door opener, HomeLink <sup>®</sup> Universal Transceiver .....	2-41
Gas cap .....	3-13
Gauge .....	2-3
Engine coolant temperature gauge .....	2-4
Fuel gauge .....	2-5
Odometer .....	2-3
Speedometer .....	2-3
Tachometer .....	2-4
General maintenance .....	8-2
Glove box .....	2-30
Glove box (upper) .....	2-31
Glove box lock .....	2-30

## H

Hazard warning flasher switch .....	2-23
Head restraints .....	1-10
Headlights	
Bulb replacement .....	8-28
Headlight switch .....	2-19
Xenon headlights .....	2-18
Heated seats .....	2-24
Heater	
Engine coolant heater .....	5-27
Heater and air conditioner (automatic) .....	4-3
HomeLink <sup>®</sup> Universal Transceiver .....	2-41
Hood release .....	3-9
Hook, Coat hook .....	2-33
Horn .....	2-23
How to stop alarm	
Vehicle security .....	2-16

## I

Ignition switch .....	5-6
Automatic transmission models .....	5-6, 5-9
Key positions .....	5-7
Manual transmission models .....	5-7, 5-14
Immobilizer system .....	2-16
In-cabin microfilter .....	4-5
Indicator lights .....	2-12
Infiniti Vehicle Immobilizer System	
Engine start .....	5-8
Inside automatic anti-glare mirror .....	3-16
Inspection/maintenance (I/M) test .....	9-22
Instrument brightness control .....	2-21

Instrument panel .....	2-2
Instrument pocket (Except for Navigation system) .....	2-28
Interior light .....	2-39
Interior light replacement .....	8-29
Interior trunk lid release .....	3-11

## J

Jump starting .....	6-8
---------------------	-----

## K

Keyless entry (See remote keyless entry system) .....	3-5
Keys .....	3-2

## L

Label, Air conditioner specification label .....	9-12
Label, Emission control information label .....	9-11
Label, F.M.V.S.S. certification label .....	9-10
Labels	
Air bag warning labels .....	1-23
Engine serial number .....	9-10
Vehicle identification number (VIN) .....	9-9
LATCH (Lower Anchors and Tethers for Children) .....	1-40
License plate, Installing front license plate .....	9-13
Light	
Air bag warning light .....	1-23
AWD warning light .....	5-19
Bulb replacement .....	8-26

Fog light switch .....	2-22
Headlight switch .....	2-19
Headlights Bulb replacement .....	8-28
Interior light.....	2-39
Map light.....	2-39
Rear personal light.....	2-40
Replacement .....	8-26
Trunk light.....	2-40
Vanity mirror light.....	2-40
Warning/indicator lights and audible reminders .....	2-9, 2-12
Xenon headlights.....	2-18
Lights, Exterior and interior light replacement .....	8-29
Loading information (See vehicle loading information) .....	9-14
Lock	
Door locks .....	3-3
Glove box lock.....	2-30
Power door lock .....	3-3
Trunk lid lock opener lever.....	3-10
Low tire pressure warning light.....	2-12
Low tire pressure warning system .....	5-3, 6-2

## M

Maintenance	
Battery .....	8-16
General maintenance .....	8-2
Inside the vehicle .....	8-4
Maintenance precautions .....	8-5
Maintenance requirements.....	8-2
Outside the vehicle.....	8-3
Seat belt maintenance .....	1-32

Malfunction indicator lamp (MIL) .....	2-13
Manual front seat adjustment .....	1-2
Meters and gauges.....	2-3
Meters and gauges, Instrument brightness control .....	2-21
Mirror	
Automatic anti-glare inside mirror .....	3-16
Outside mirror control.....	3-16
Outside mirrors.....	3-16

## N

New vehicle break-in .....	5-18
Nissan Vehicle Immobilizer System .....	2-16

## O

Odometer .....	2-3
Oil	
Capacities and recommended fuel/lubricants .....	9-2
Changing engine oil and filter .....	8-11
Checking engine oil level .....	8-10
Engine oil.....	8-10
Engine oil viscosity .....	9-5
Outside mirror control .....	3-16
Outside mirrors .....	3-16
Overheat, If your vehicle overheats.....	6-10
Owner's Manual/Service Manual order information .....	9-24

## P

Parking	
Brake check.....	8-21
Parking brake check.....	5-15
Parking brake operation.....	5-15
Parking on hills.....	5-15
Parking/parking on hills .....	5-21
Phone, Car phone or CB radio.....	4-18
Power	
Front seat adjustment .....	1-4
Power door lock .....	3-3
Power outlet .....	2-26
Power steering fluid.....	8-13
Power steering system.....	5-22
Power windows .....	2-34
Pre-tensioner seat belt system.....	1-22
Precautions	
Audio operation .....	4-8
Braking precautions.....	5-22
Child restraints .....	1-33
Cruise control .....	5-17
Maintenance .....	8-5
Seat belt usage .....	1-25
Supplemental restraint system.....	1-11
When starting and driving.....	5-2
Push starting.....	6-10

## R

Radio, Car phone or CB radio.....	4-18
Readiness for inspection/maintenance (I/M) test (US only) .....	9-22

Rear armrest pocket .....	2-32
Rear power point .....	2-26
Rear seat adjustment .....	1-7
Rear window and outside mirror defroster switch .....	2-18
Registering your vehicle in another country .....	9-9
Remote keyless entry system.....	3-5
Reporting safety defects (US only).....	9-22
Roadside assistance program .....	6-2
Rollover.....	5-4

## S

Safety	
Child seat belts.....	1-28
Reporting safety defects (US only) .....	9-22
Towing safety .....	9-17
Satellite radio operation .....	4-12
Seat	
Belt warning light.....	1-26
Belt warning light and chime .....	2-11
Seat adjustment	
Front manual seat adjustment .....	1-2
Front power seat adjustment .....	1-4
Rear seat adjustment .....	1-7
Seat belt(s)	
Child safety.....	1-28
Infants and small children .....	1-28
Injured persons.....	1-29
Larger children .....	1-28
Pre-tensioner seat belt system .....	1-22
Precautions on seat belt usage .....	1-25
Pregnant women .....	1-28
Seat belt cleaning.....	7-4

Seat belt extenders .....	1-32
Seat belt maintenance .....	1-32
Seat belts .....	1-25
Three-point type with retractor .....	1-29
Seat(s)	
Driver-side memory .....	3-18
Heated seats .....	2-24
Seats .....	1-2
Secondary trunk lid release .....	3-11
Security system, Vehicle security system .....	2-15
Security systems (Infiniti Vehicle Immobilizer System), Engine start .....	2-16
Security systems (See vehicle security system) .....	2-15
Servicing air conditioner.....	4-3, 4-6
Shift lock release .....	5-13
Shifting	
Automatic transmission.....	5-6, 5-9
Manual transmission .....	5-7, 5-14
Shoulder belt guide .....	1-32
Shoulder belt height adjustment (For Sedan front seats) .....	1-31
Side air bag system (See supplemental side air bag and curtain side-impact air bag system) .....	1-20
Spark plugs.....	8-18
Speedometer .....	2-3
Starting	
Before starting the engine.....	5-8
Jump starting.....	6-8
Precautions when starting and driving.....	5-2
Push starting .....	6-10
Starting the engine .....	5-9
Steering	

Power steering fluid.....	8-13
Power steering system.....	5-22
Tilting steering wheel .....	3-15
Storage .....	2-28
Stowing golf bags .....	2-33
Sun shade.....	2-37
Sun visors .....	3-15
Sunglasses holder .....	2-28
Sunroof .....	2-37
Automatic sunroof .....	2-37
Supplemental air bag warning labels .....	1-23
Supplemental air bag warning light.....	1-23, 2-11
Supplemental restraint system .....	1-11
Precautions on supplemental restraint system .....	1-11
Supplemental side and curtain side-impact air bag system .....	1-20
Switch	
Autolight switch .....	2-20
Fog light switch .....	2-22
Hazard warning flasher switch .....	2-23
Headlight switch .....	2-19
Ignition switch.....	5-6
Ignition switch automatic transmission models.....	5-6, 5-9
Ignition switch manual transmission models.....	5-7, 5-14
Power door lock switch .....	3-4
Rear window and outside mirror defroster switch .....	2-18
Snow mode switch .....	2-25
Turn signal switch .....	2-22
Vehicle dynamic control (VDC) off switch.....	2-25

## T

Tachometer .....	2-4
Temperature gauge, Engine coolant temperature gauge .....	2-4
Theft (Infiniti Vehicle Immobilizer System), Engine start .....	2-16
Three way catalyst.....	5-3
Tilting steering wheel.....	3-15
Tire	
Flat tire .....	6-2
Low tire pressure warning system .....	5-3
Pressure, Low tire pressure warning light .....	2-12
Uniform tire quality grading .....	9-20
Tires	
Spare tire.....	8-42
Tire and loading information label ...	8-34, 9-11
Tire chains.....	8-38
Tire pressure .....	8-33
Tire rotation .....	8-39
Types of tires.....	8-37
Wheel/tire size .....	9-8
Wheels and tires .....	8-33
Top tether strap child restraints.....	1-41
Towing	
Tow truck towing .....	6-11
Towing a trailer.....	9-16
Towing load/specification chart .....	9-17
Towing safety .....	9-17
Trailer towing .....	9-16
Transceiver, HomeLink <sup>®</sup> Universal Transceiver .....	2-41
Transmission	

Automatic transmission fluid (ATF) .....	8-13
Driving with automatic transmission ....	5-6, 5-9
Driving with manual transmission .....	5-7, 5-14
Transmission selector lever lock release .....	5-13
Transmitter (See remote keyless entry system) .....	3-5
Traveling or registering your vehicle in another country .....	9-9
Trunk	
Access through rear seat .....	1-8
Interior trunk lid release .....	3-11
Lid lock opener lever.....	3-10
Light.....	2-40
Secondary trunk lid release .....	3-11
Turn signal switch.....	2-22

## U

Underbody cleaning.....	7-3
Uniform tire quality grading.....	9-20

## V

Vanity mirror light.....	2-40
Vehicle	
Dimensions and weights .....	9-8
Identification number (VIN) .....	9-9
Loading information.....	9-14
Recovery (freeing a stuck vehicle).....	6-14
Security system .....	2-15
Vehicle dynamic control (VDC) off switch.....	2-25
Vehicle dynamic control (VDC) system .....	5-24

Ventilators .....	4-2
-------------------	-----

## W

Walk-in mechanism .....	1-6
Warning labels, Air bag warning labels.....	1-23
Warning light	
Air bag warning light .....	1-23, 2-11
Anti-lock brake warning light .....	2-9
AWD (all wheel drive) warning light.....	2-10
Brake warning light.....	2-10
Door open warning light .....	2-11
Low tire pressure warning light .....	2-12
Seat belt warning light and chime.....	2-11
Warning lights .....	2-9
Warning, Hazard warning flasher switch .....	2-23
Warning, Low tire pressure warning system ....	5-3
Warning, Warning/indicator lights and audible reminders .....	2-9
Warranty, Emission control system warranty .....	9-21
Washer switch, Windshield wiper and washer switch .....	2-17
Washing .....	7-2
Waxing .....	7-2
Weights (See dimensions and weights) .....	9-8
Wheel/tire size .....	9-8
Wheels and tires .....	8-33
Cleaning aluminum alloy wheels.....	7-3
Window washer fluid.....	8-15



Window(s)  
    Cleaning ..... 7-3  
    Power windows ..... 2-34  
Windshield wiper and washer switch..... 2-17  
Wiper  
    Windshield wiper and washer switch ..... 2-17  
    Wiper blades ..... 8-19

**X**

Xenon headlights ..... 2-18

**MEMO**

10-8

**MEMO**

**MEMO**

10-10

**MEMO**

**MEMO**

10-12

## GAS STATION INFORMATION

### FUEL RECOMMENDATION:

#### Sedan models

Use unleaded regular gasoline with an octane rating of at least 87 AKI (Anti-Knock Index) number (Research octane number 91).

For improved vehicle performance, INFINITI recommends the use of unleaded premium gasoline with an octane rating of at least 91 AKI number (Research octane number 96).

#### Coupe models

Use unleaded premium gasoline with an octane rating of at least 91 AKI (Anti-Knock Index) number (Research octane number 96).

If premium gasoline is not available, unleaded regular gasoline with an octane rating of 87 AKI number (Research octane number 91) may be temporarily used, but only under the following precautions:

- Have the fuel tank filled only partially with unleaded regular gasoline, and fill up with unleaded premium gasoline as soon as possible.
- Avoid full throttle driving and abrupt acceleration.

**However, for maximum vehicle performance, the use of unleaded premium gasoline is recommended.**



### CAUTION

**Using a fuel other than that specified could adversely affect the emission control systems, and may also affect warranty coverage.**

**Under no circumstances should a leaded gasoline be used, since this will damage the three way catalyst.**

For additional information, see “Capacities and recommended fuel/lubricants” in the “9. Technical and consumer information” section.

### ENGINE OIL RECOMMENDATION:

- API Certification Mark
- API grade SG/SH, Energy Conserving I & II or API grade SJ or SL, Energy Conserving
- ILSAC grade GF-I, GF-II & GF-III
- SAE 5W-30 viscosity oil is preferred for all ambient temperatures. SAE 10W-30 viscosity oil may be used for ambient temperatures above 0°F (-18°C).

See “Capacities and recommended fuel/lubricants” in the “9. Technical and consumer information” section for engine oil and oil filter recommendation.

### COLD TIRE PRESSURES:

See Tire and Loading Information label affixed to the inside of the driver side center pillar.

### NEW VEHICLE BREAK-IN PROCEDURES RECOMMENDATION:

During the first 1,200 miles (2,000 km) of vehicle use, follow the recommendations outlined in the “Break-in schedule” Information found in the “5. Starting and driving” section of this Owner’s Manual. Follow these recommendations for the future reliability and economy of your new vehicle.

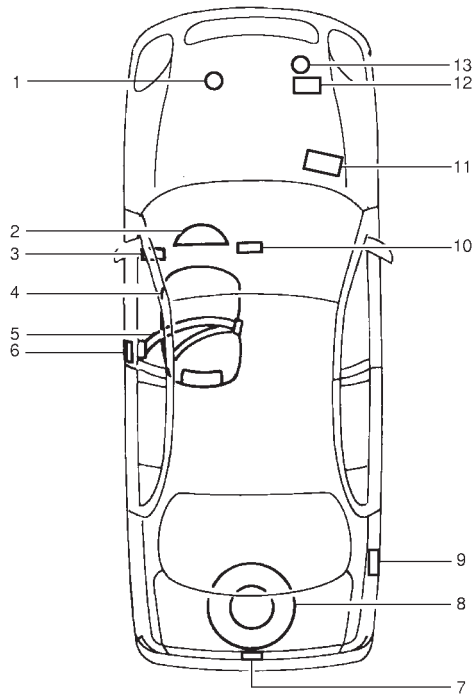

1. Engine oil 8-10
2. Meters and gauges 2-3
3. Hood release 3-9
4. Seat 1-2
5. Seat belt 1-25
6. Key 3-2
7. Trunk release 3-11
8. Spare tire 6-4, 8-42
9. Fuel 3-12, 9-2
10. Audio system 4-6  
Heater and air conditioner 4-3
11. Battery 8-16
12. Engine coolant 8-8
13. Windshield washer fluid 8-15