

Foreword

Your INFINITI represents a new way of thinking about vehicle design. It integrates advanced engineering and superior craftsmanship with a simple, refined aesthetic sensitivity associated with traditional Japanese culture.

The result is a different notion of luxury and beauty. The car itself is important, but so is the sense of harmony that the vehicle evokes in its driver, and the sense of satisfaction you feel with the INFINITI — from the way it looks and drives to the high level of retailer service.

To ensure that you enjoy your INFINITI to the fullest, we encourage you to read this Owner's Manual immediately. It explains all of the features, controls and performance characteristics of your INFINITI; it also provides important instructions and safety information.

A separate Warranty Information Booklet can be found in your Owner's literature portfolio. The INFINITI Service and Maintenance Guide explains details about maintaining and servicing your vehicle. Always carry it with you when you take your INFINITI to an authorized retailer. The portfolio contents provide complete information about all warranties covering this vehicle, the periodic maintenance re-

quired to keep the warranties in effect as well as the INFINITI Roadside Assistance program.

Additionally, a separate Customer Care and Lemon Law Information Booklet will explain how to resolve any concerns you may have with your vehicle, as well as clarify your rights under your state's lemon law.

INFINITI is dedicated to providing a satisfying ownership experience for as long as you own your car. Should you have any questions regarding your INFINITI or an INFINITI dealer, please contact our Consumer Affairs department at:
In U.S. 1-800-662-6200.
In Canada 1-800-361-4792.

READ FIRST — THEN DRIVE SAFELY

Before driving your vehicle please read your Owner's Manual carefully. This will ensure familiarity with controls and maintenance requirements, assisting you in the safe operation of your vehicle.



WARNING

IMPORTANT SAFETY INFORMATION REMINDERS FOR SAFETY!

Follow these important driving rules to help ensure a safe and comfortable trip for you and your passengers!

- **Never drive under the influence of alcohol or drugs.**
- **Always observe posted speed limits and never drive too fast for conditions.**
- **Always use seat belts and child restraints. Pre-teen children should be seated in the rear seat.**
- **Always provide information about the proper use of vehicle safety features to all occupants of the vehicle.**
- **Always review this Owner's Manual for important safety information.**

MODIFICATION OF YOUR VEHICLE

This vehicle should not be modified. Modification could affect its performance, safety or durability, and may even violate governmental regulations. In addition, damage or performance problems resulting from modifications may not be covered under INFINITI warranties.

WHEN READING THE MANUAL

This manual includes information for all options available on this model. Therefore, you may find some information that does not apply to your vehicle.

All information, specifications and illustrations in this manual are those in effect at the time of printing. INFINITI reserves the right to change specifications or design at any time without notice.

IMPORTANT INFORMATION ABOUT THIS MANUAL

You will see various symbols in this manual. They are used in the following ways:



WARNING

This is used to indicate the presence of a hazard that could cause death or serious personal injury. To avoid or reduce the risk, the procedures must be followed precisely.



CAUTION

This is used to indicate the presence of a hazard that could cause minor or moderate personal injury or damage to your vehicle. To avoid or reduce the risk, the procedures must be followed carefully.

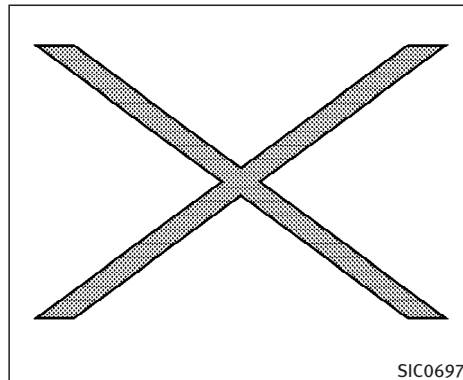

If you see this symbol, it means **Do not do this** or **Do not let this happen**.



If you see a symbol similar to these in an illustration, it means the arrow points to the front of the vehicle.



Arrows in an illustration that are similar to these indicate movement or action.



Arrows in an illustration that are similar to these call attention to an item in the illustration.

CALIFORNIA PROPOSITION 65 WARNING



WARNING

Engine exhaust, some of its constituents, and certain vehicle components contain or emit chemicals known to the State of California to cause cancer and birth defects or other reproductive harm. In addition, certain fluids contained in vehicles and certain products of component wear contain or emit chemicals known to the State of California to cause cancer and birth defects or other reproductive harm.



BLUETOOTH® is a trademark owned by Bluetooth SIG, Inc., U.S.A. and licenced to Xanavi Informatics Corporation.



© 2005 NISSAN MOTOR CO., LTD.
TOKYO, JAPAN

All rights reserved. No part of this Owner's Manual may be reproduced or stored in a retrieval system, or transmitted in any form, or by any means, electronic, mechanical, photocopying, recording or otherwise, without the prior written permission of Nissan Motor Co., Ltd.

Table of Contents

Illustrated table of contents	0
Safety – Seats, seat belts and supplemental restraint system	1
Instruments and controls	2
Pre-driving checks and adjustments	3
Display screen, heater, air conditioner and audio systems	4
Starting and driving	5
In case of emergency	6
Appearance and care	7
Maintenance and do-it-yourself	8
Technical and consumer information	9
Index	10

0 Illustrated table of contents

Air bags, seat belts and child restraints.....	0-2	Sedan model.....	0-7
Exterior.....	0-3	Coupe model	0-8
Sedan model.....	0-3	Instrument panel.....	0-9
Coupe model.....	0-5	Meters and gauges.....	0-11
Passenger compartment	0-7	Engine compartment	0-12

AIR BAGS, SEAT BELTS AND CHILD RESTRAINTS

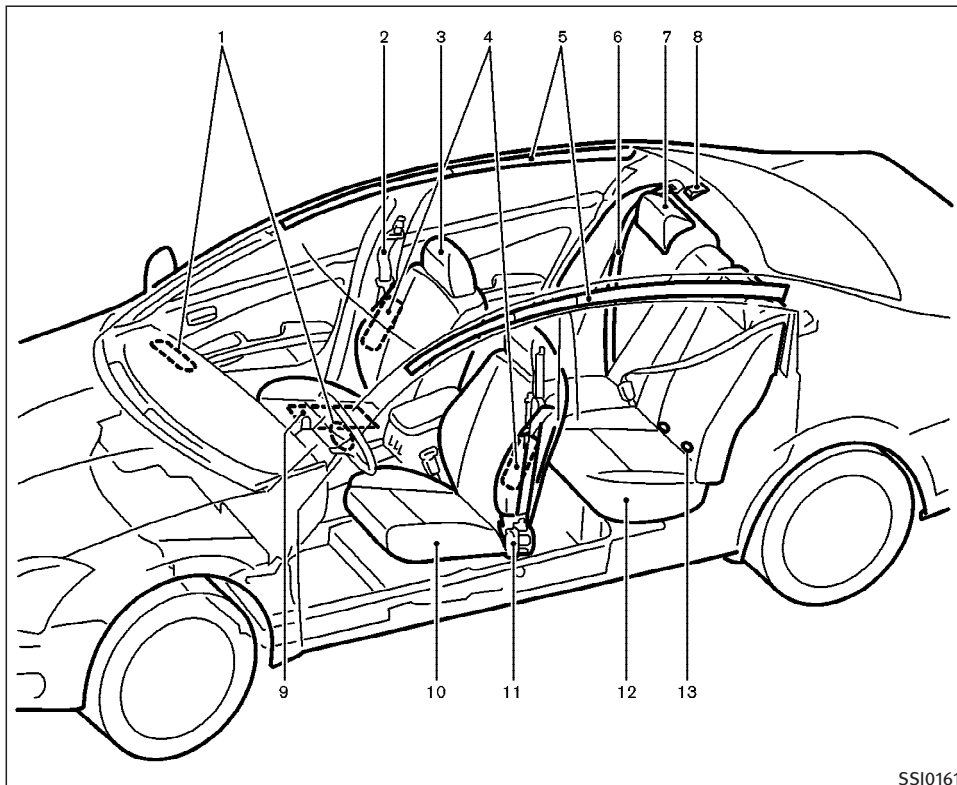

1. Supplemental front-impact air bags (Page 1-36)
2. Front seat belts (P.1-9)
3. Front head restraints (P.1-8)
4. Supplemental side air bags (P.1-36)
5. Supplemental curtain side-impact air bags (P.1-36)
6. Rear seat belts (P.1-9)
7. Rear head restraints (P.1-8)
8. Child restraint anchor points (for top tether strap child restraint) (P.1-26)
9. Occupant classification sensor (pressure sensor) (P.1-42)
10. Front seats (P.1-2)
11. Pre-tensioner seat belt system (P.1-50)
12. Rear seats (P.1-5)
 - Child restraints (P.1-18)
13. LATCH (Lower Anchors and Tethers for Children) system (P.1-25)

SSI0161

EXTERIOR

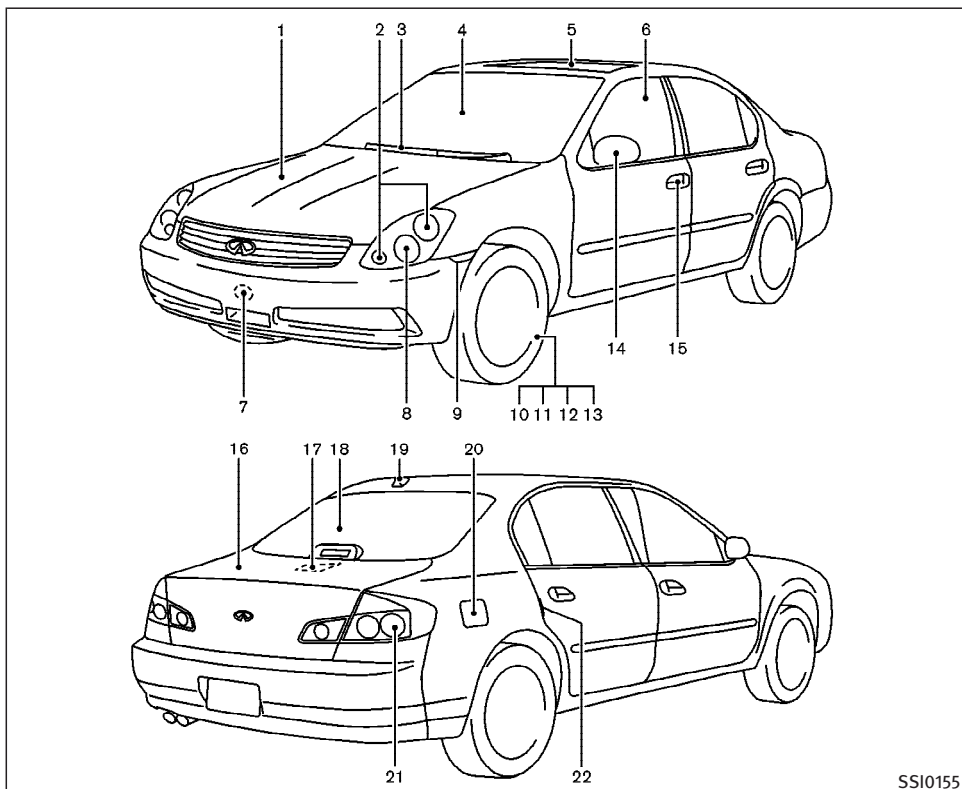

SSI0155

SEDAN MODEL

1. Engine hood (P.3-24)
2. Headlight and turn signal switch (P.2-21)
3. Windshield wiper and washer switch (P.2-19)
4. Windshield (P.8-21)
5. Sunroof* (P.2-42)
6. Power windows (P.2-39)
7. Recovery hook (P.6-15)
8. Fog light switch (P.2-25)
9. Front side marker light (P.8-33)
10. Tire pressure (P.8-37)
11. Flat tire (P.6-2)
12. Tire chains (P.8-44)
13. Tire pressure monitoring system (TPMS) (P.2-12, 5-3)
14. Mirrors (P.3-32)
15. Door locks, keyfob, keys (P.3-3)
16. Trunk lid (P.3-25)
17. Interior trunk lid release (P.3-27)
18. Rear window defogger switch (P.2-20)
19. Satellite antenna (P.4-14)
20. Fuel-filler door (P.3-28)

21. Rear combination light (P.8-33)

22. Child safety locks (P.3-5)

*: if so equipped

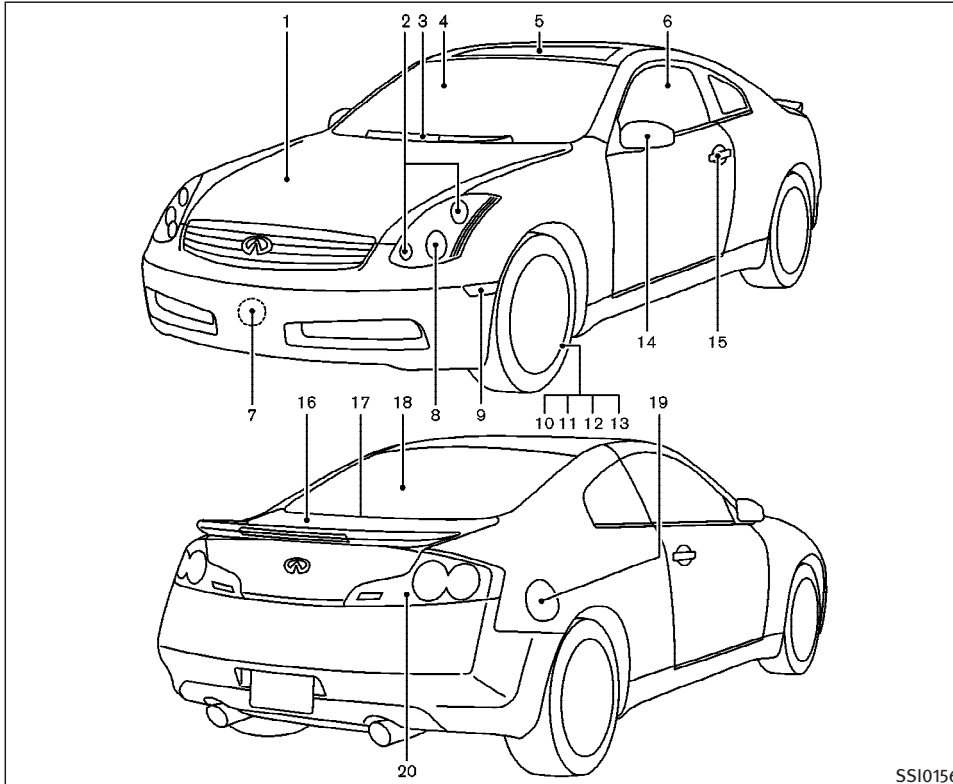

SSI0156

COUPE MODEL

1. Engine hood (P.3-24)
2. Headlight and turn signal switch (P.2-21)
3. Windshield wiper and washer switch (P.2-19)
4. Windshield (P.8-21)
5. Sunroof* (P.2-42)
6. Power windows (P.2-39)
7. Recovery hook (P.6-15)
8. Fog light switch (P.2-25)
9. Front side marker light (P.8-33)
10. Tire pressure (P.8-37)
11. Flat tire (P.6-2)
12. Tire chains (P.8-44)
13. Tire pressure monitoring system (TPMS) (P.2-12, 5-3)
14. Mirrors (P.3-32)
15. Door locks, keyfob, keys (P.3-3)
16. Trunk lid (P.3-25)
17. Interior trunk lid release (P.3-27)
18. Rear window defogger switch (P.2-20)
19. Fuel-filler door (P.3-28)

20. Rear combination light (P.8-33)

*: if so equipped

PASSENGER COMPARTMENT

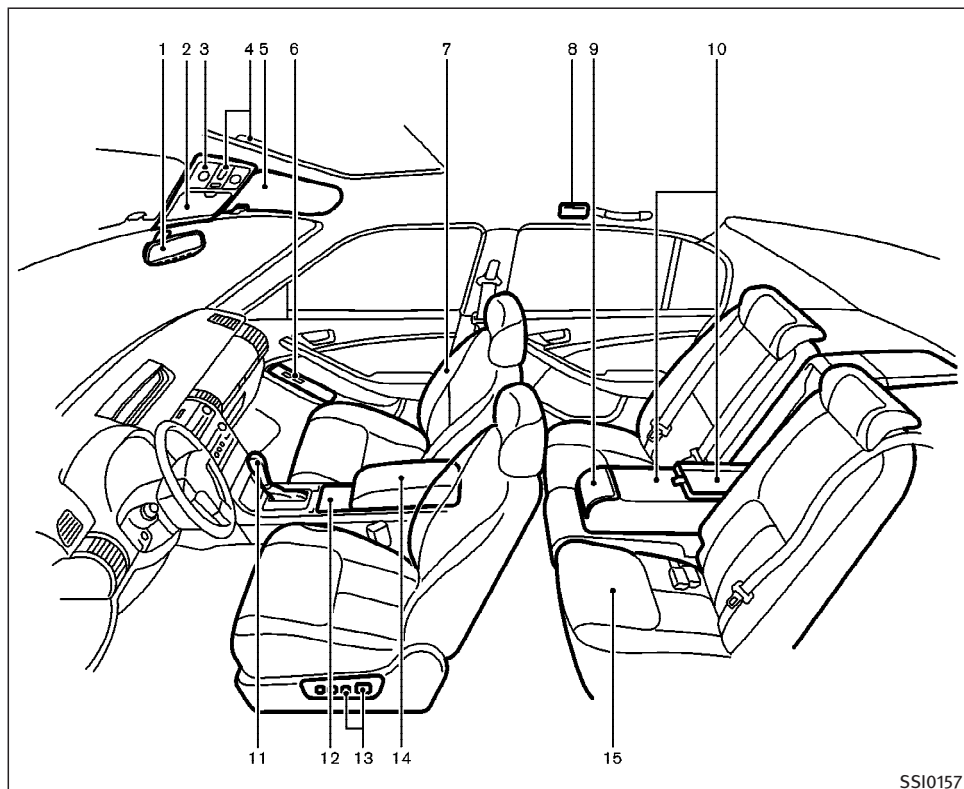

SSI0157

SEDAN MODEL

1. Automatic anti-glare mirror, HomeLink® (P.3-32, 2-46)
 2. Sunglasses holder (P.2-42)
 3. Interior lights (P.2-44)
 4. Sunroof* (P.2-42)
 5. Sun visor (P.3-32)
 6. Power window switch/Power door lock switch (P.2-39, 3-4)
 7. Front seat (P.1-2)
 8. Rear personal light (P.2-45)
 9. Rear cup holder (P.2-34)
 10. Armrest (P.1-9)
 11. Selector lever
 - Automatic transmission (P.5-12)
 - Manual transmission (P.5-16)
 12. Front cup holder (P.2-32)
 13. Automatic drive positioner switches* (P.3-34)
 14. Console box (P.2-36)
 15. Rear seat (P.1-5)
- *: if so equipped

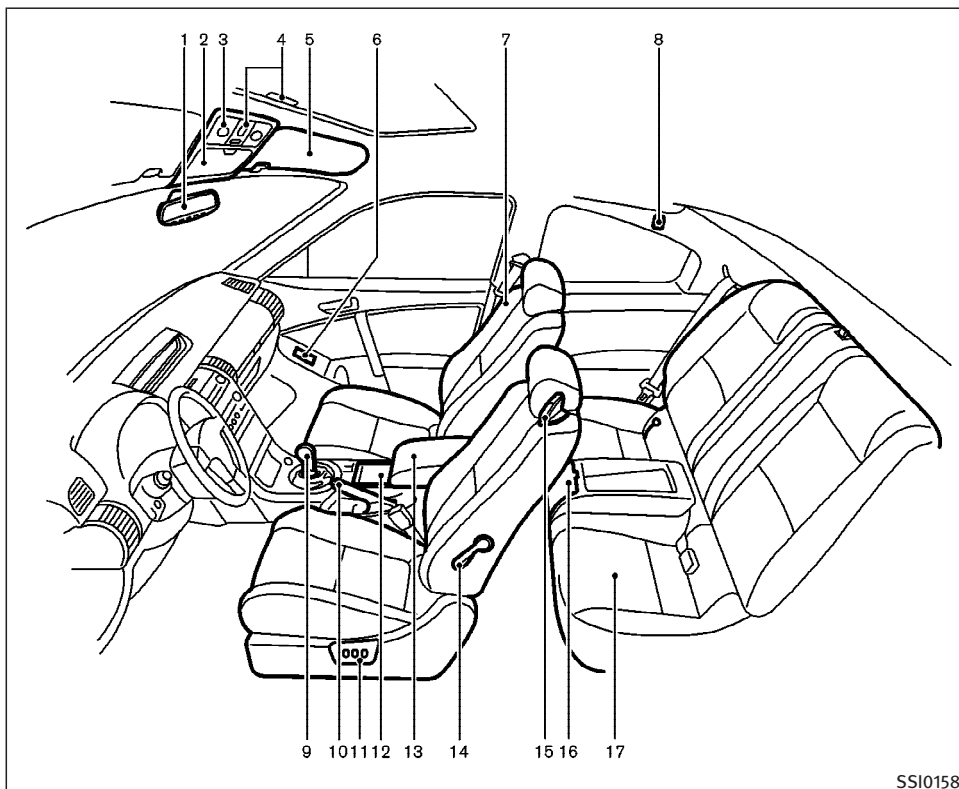

SSI0158

COUPE MODEL

1. Automatic anti-glare mirror, HomeLink® (P.3-32, 2-46)
 2. Sunglasses holder (P.2-32)
 3. Interior lights (P.2-44)
 4. Sunroof* (P.2-42)
 5. Sun visor (P.3-32)
 6. Power window switch/Power door lock switch (P.2-39, 3-4)
 7. Front seat (P.1-2)
 8. Coat hook (P.2-38)
 9. Selector lever or Shift lever
 - Automatic transmission (P.5-12)
 - Manual transmission (P.5-16)
 10. Parking brake (P.5-19)
 11. Automatic drive positioner switches* (P.3-34)
 12. Front cup holder (P.2-32)
 13. Console box (P.2-36)
 14. Walk-in mechanism* (P.1-4)
 15. Shoulder belt guide (P.1-17)
 16. Rear cup holder (P.2-34)
 17. Rear seat (P.1-5)
- *: if so equipped

INSTRUMENT PANEL

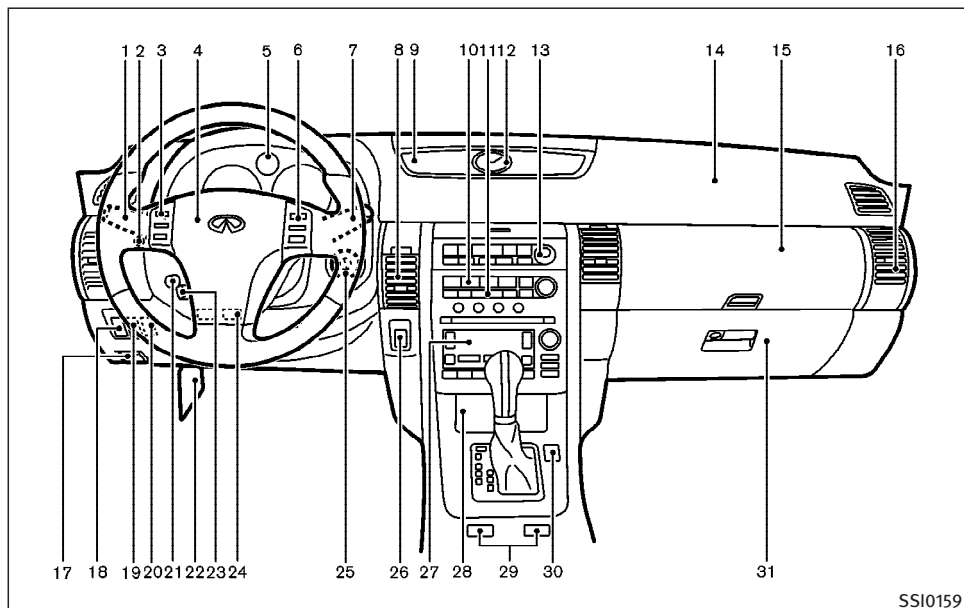

1. Headlight, fog light and turn signal switch (P.2-21)
2. Security indicator light (P.2-19)
3. Steering wheel switch for audio control (P.4-28) or steering wheel switch for Bluetooth® Hands-Free Phone System (if so equipped) (P.4-30)

4. Driver's supplemental front air bag (P.1-36)/Horn (P.2-26)
5. Meters/gauges (P.2-3)
6. Cruise control main/set switch (P.5-20)
7. Windshield wiper/washer switch (P.2-19)
8. Center ventilator (P.4-9)

9. Center display - Compass, Air conditioner, Ambient temperature, Front passenger air bag status light (P.1-44)
10. Rear window and outside mirror defogger switch (P.2-20)
11. Heater/air conditioner control (P.4-10)
12. Clock (P.2-29)
13. Navigation system* (if so equipped) (P.4-2)
14. Passenger's supplemental front air bag (P.1-36)
15. Upper glove box (except for Navigation system equipped models) (P.2-35)
16. Side ventilator (P.4-9)
17. Hood lock release handle (P.3-24)
18. Trunk lid release switch (P.3-25)
19. Vehicle Dynamic Control (VDC) off switch (P.2-28)
20. Instrument brightness control (P.2-24)
21. Outside mirror remote control switch (P.3-33)
22. Fuse box (P.8-27)
23. Electric steering column control (if so equipped) (P.3-31)
24. Manual steering column control (P.3-30)
25. Ignition switch/steering lock (P.5-6)
26. SNOW mode switch (if so equipped) (P.2-27)
27. Audio system (P.4-14)
28. Ashtray/Cigarette lighter (P.2-30)
29. Heated seat switch (P.2-26)

30. Hazard warning flasher switch
(P.2-25)

31. Glove box (P.2-35)

*: Refer to the separate Navigation System
Owner's Manual.

METERS AND GAUGES

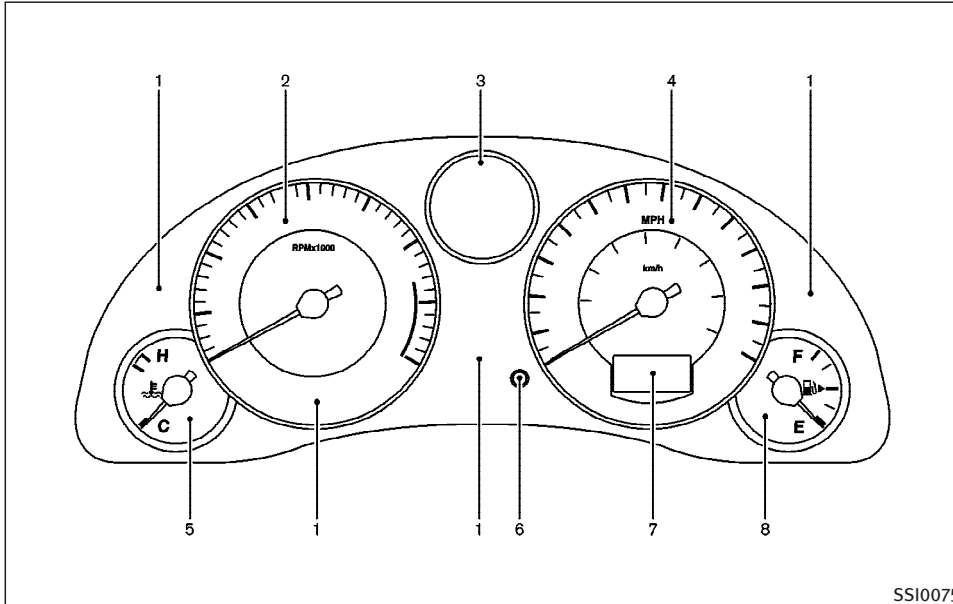

1. Warning/Indicator lights (P.2-9)
2. Tachometer (P.2-4)
3. Automatic transmission position indicator (AT models) (P.5-12)/Manual transmission up-shift indicator (MT models) (P.5-16)
4. Speedometer (P.2-3)
5. Engine coolant temperature gauge (P.2-4)
6. Trip odometer reset switch (P.2-3)
7. Odometer (Total/Twin trip) (P.2-3)/Up-shift indicator setting (MT models)
8. Fuel gauge (P.2-5)

ENGINE COMPARTMENT

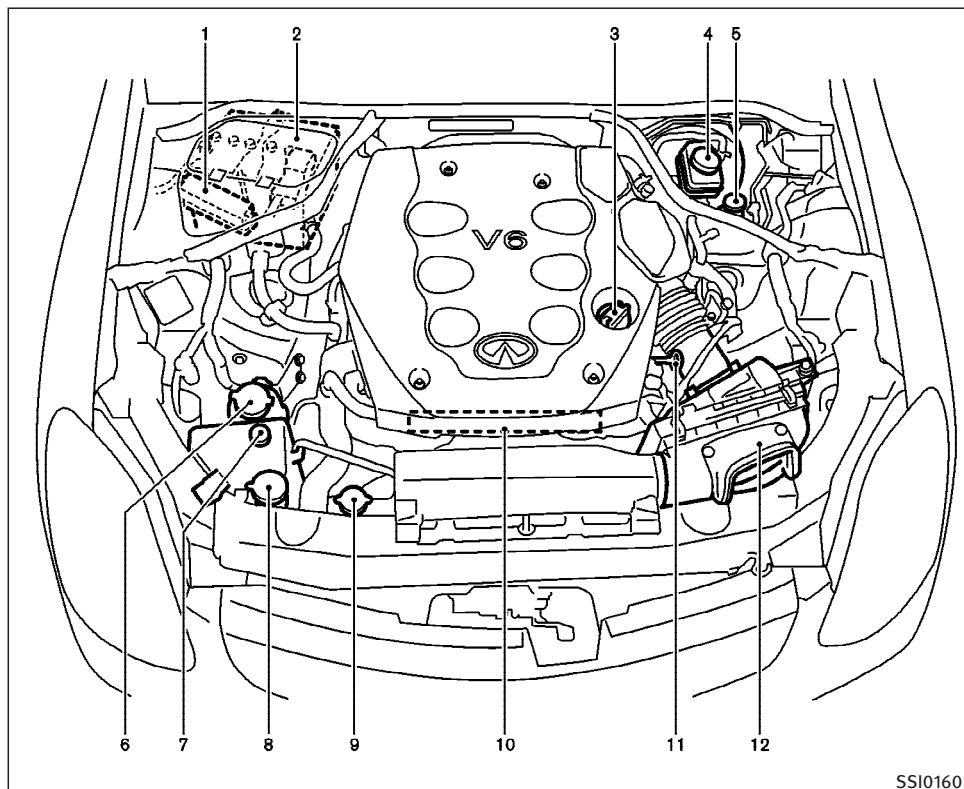

VQ35DE

1. Fuse/fusible link holder (P.8-25)
2. Battery (P.8-16)
3. Engine oil filler cap (P.8-10)
4. Brake fluid reservoir (P.8-14)
5. Clutch fluid reservoir (MT models) (P.8-15)
6. Power steering fluid reservoir (P.8-13)
7. Engine coolant reservoir (P.8-8)
8. Window washer fluid reservoir (P.8-15)
9. Radiator filler cap (P.8-9)
10. Drive belts (P.8-19)
11. Engine oil dipstick (P.8-10)
12. Air cleaner (P.8-20)

SSI0160

1 Safety — Seats, seat belts and supplemental restraint system

Seats	1-2	Top tether strap child restraint	1-26
Front power seat adjustment	1-2	Child restraint installation on front	
Rear seat adjustment	1-5	passenger seat	1-28
Head restraint adjustment	1-8	Booster seats	1-31
Active head restraint (front seats).....	1-8	Precautions on booster seats	1-31
Armrest (if so equipped)	1-9	Booster seat installation on rear seat	
Seat belts	1-9	outboard or center positions.....	1-34
Precautions on seat belt usage.....	1-9	Booster seat installation on front	
Child safety	1-12	passenger seat	1-35
Pregnant women	1-13	Supplemental restraint system.....	1-36
Injured persons	1-13	Precautions on supplemental restraint	
Three-point type seat belt with retractor.....	1-13	system.....	1-36
Seat belt extenders	1-17	INFINITI advanced air bag system (front	
Seat belt maintenance.....	1-17	seats)	1-42
Child restraints.....	1-18	Supplemental side air bag and curtain	
Precautions on child restraints.....	1-18	side-impact air bag systems	1-48
Child restraint installation on rear seat		Supplemental air bag warning labels.....	1-51
outboard or center positions	1-20	Supplemental air bag warning light.....	1-51
LATCH (Lower Anchors and Tethers for			
Children) SYSTEM	1-25		

SEATS

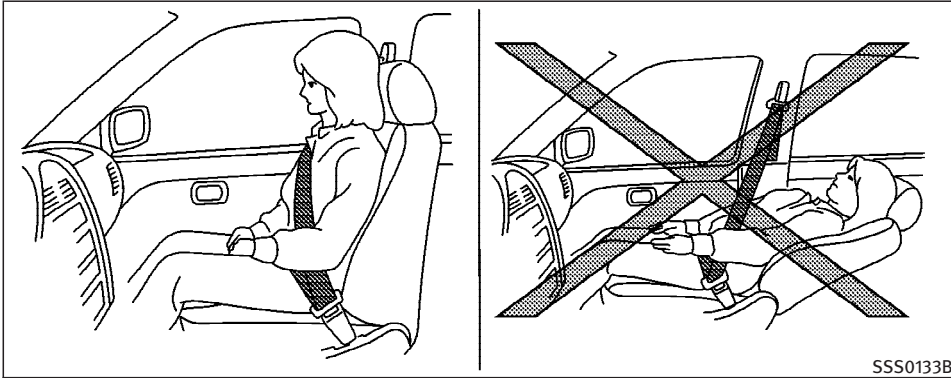

WARNING

- Do not ride in a moving vehicle when the seatback is reclined. This can be dangerous. The shoulder belt will not be against your body. In an accident, you could be thrown into it and receive neck or other serious injuries. You could also slide under the lap belt and receive serious internal injuries.

- For the most effective protection when the vehicle is in motion, the seat should be upright. Always sit well back in the seat and adjust the seat belt properly. See “Precautions on seat belt usage” later in this section.

FRONT POWER SEAT ADJUSTMENT



WARNING

- Do not adjust the driver’s seat while driving so full attention may be given to vehicle operation.
- Do not leave children unattended inside the vehicle. They could unknowingly activate switches or controls. Unattended children could become involved in serious accidents.

Operating tips

- The seat motor has an auto-reset overload protection circuit. If the motor stops during operation, wait 30 seconds, then reactivate the switch.
- Do not operate the power seat for a long period of time when the engine is off. This will discharge the battery.

See “Automatic drive positioner” in the “3. Pre-driving checks and adjustments” for automatic seat positioner operation (if so equipped).

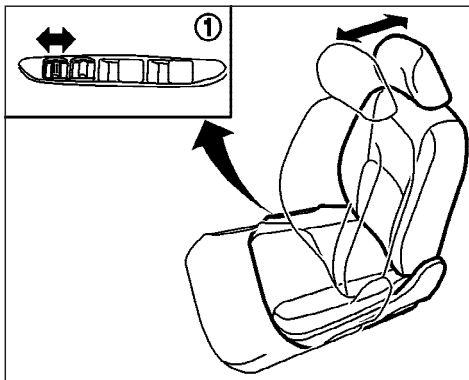

Forward and backward

Moving the switch ① forward or backward will slide the seat forward or backward to the desired position.

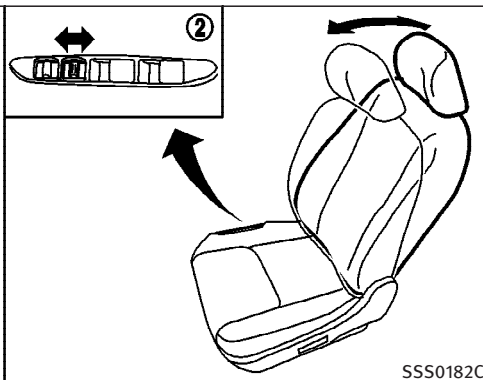

SSS0182C

Reclining

Move the recline switch ② backward until the desired angle is obtained. To bring the seatback forward again, move the switch forward and move your body forward. The seatback will move forward.

The reclining feature allows adjustment of the seatback for occupants of different sizes for added comfort and to help obtain proper seat belt fit. See “Precautions on seat belt usage” later in this section. The seatback may also be reclined to allow occupants to rest when the vehicle is parked.

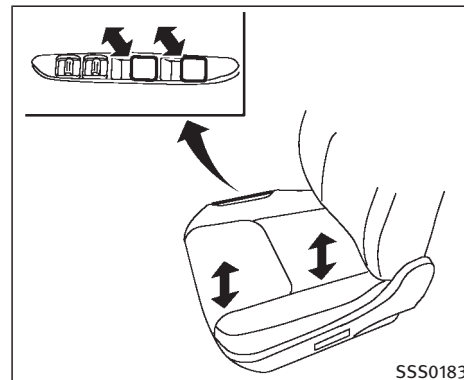

SSS0183

Seat lifter (Driver's seat)

Pull the switch up or push it down to adjust the angle and height of the seat.

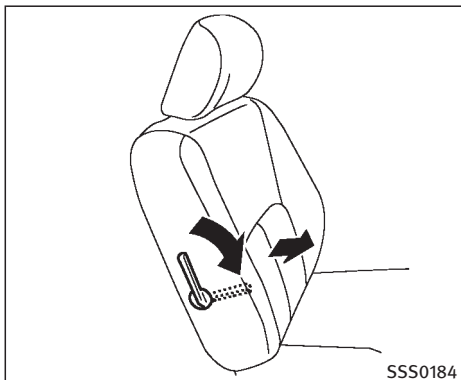

Lumbar support (Driver's seat)

The lumbar support feature provides lower back support to the driver. Move the lever up or down to adjust the seat lumbar area.

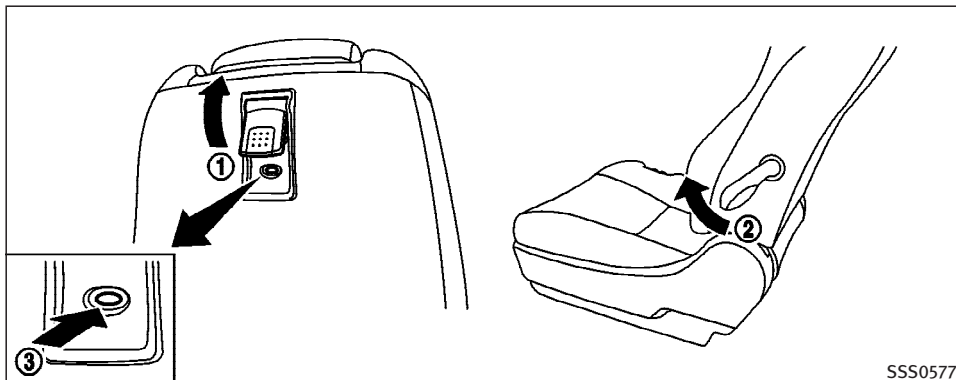

Walk-in mechanism (Coupe)

This feature makes it easier to get in and out of the rear seat. Use the following procedure when getting in and out of the rear seat.

1. Pull the seatback lever upward ① or pull the walk-in lever ② on the side of the front seat upward to fold the front seatback down.
2. To slide the front seat forward, push the seatback switch ③ below the seatback lever. The front seat will move forward.

3. Get in or out of the vehicle.

4. Push the seatback switch ③ again to return the front seat to its original position and raise the seatback.

- The front passenger seat will stop at 7 in (175 mm) from its front most position to retain space for the rear passenger.



CAUTION

- Do not raise the seatback before re-

turning the front seat to its original position.

- When returning the seat to its original position, confirm the seat and seatback are locked properly.
- Be careful not to pinch your hand or foot or bump your head when operating the walk-in seat. The seatback will fold down rapidly.
- Do not place any objects near the seatback of the front seats. They may be pinched and damaged.
- Remove the seat belt from the seat belt guide when operating the walk-in mechanism to prevent the belt from being stretched along with the seat movement.

The automatic forwarding and reversing will not work or stop under the following conditions:

- When the vehicle speed is above 4 MPH (7 km/h).
- When the seat belt is fastened.

- When the selector lever is not in the P (Park) position (Automatic transmission model's driver's seat) or the parking brake is not applied (Manual transmission model's driver's seat).
- When the door is closed.
- When the seat is raised or when the seatback switch, recline switch or slide switch is operated during automatic operation.

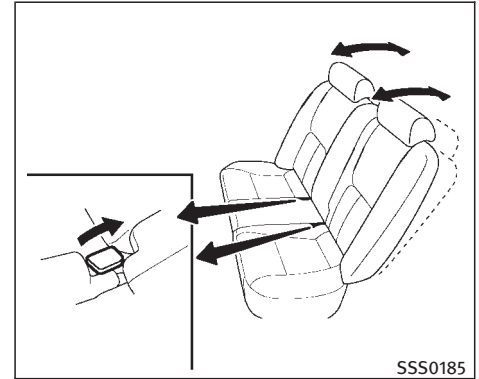

REAR SEAT ADJUSTMENT

Reclining (if so equipped)

1. Pull the adjusting lever.
2. Tilt the seatback to the desired position.
3. Release the adjusting lever to lock the seatback in position.

The reclining feature allows adjustment of the seatback for occupants of different sizes for added comfort and to help obtain proper seat belt fit. See “Precautions on seat belt usage” later in this section.

The seatback may also be reclined to allow occupants to rest when the vehicle is parked.



WARNING

- Do not ride in a moving vehicle when the seatback is reclined. This can be dangerous. The shoulder belt will not be against your body. In an accident, you could be thrown into it and receive neck or other serious injuries. You could also slide under the lap belt and receive serious internal injuries.
- For the most effective protection when the vehicle is in motion, the seat should be upright. Always sit well back in the seat and adjust the seat belt properly. See “Precautions on seat belt usage” later in this section.
- After adjustment, gently rock in the seat to make sure it is securely locked.

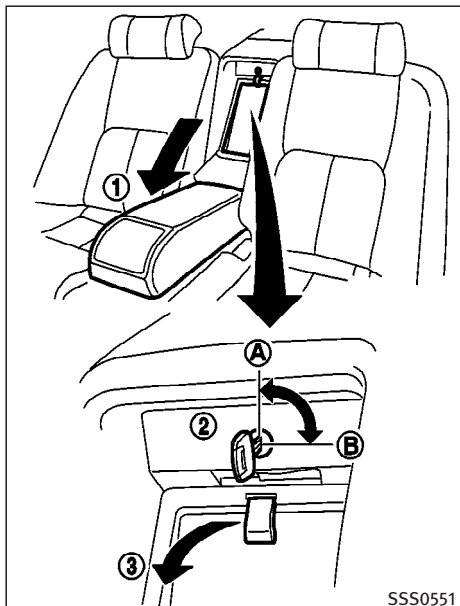

Folding

Sedan:

The rear center seatback can be folded to allow access to the trunk from inside the vehicle.

To access the trunk:

1. Fold down the rear center seatback (1).
2. Unlock the trunk access window lid (2).
To unlock, insert the master key or the mechanical key (Intelligent Key equipped model) to the key cylinder on the lid and turn it counterclockwise (A). Turning the key clockwise (B) will lock the lid.
3. Pull out the trunk access window lid (3).

Remove the key when opening or closing the trunk access window lid. Otherwise, the trunk access window lid may be damaged.

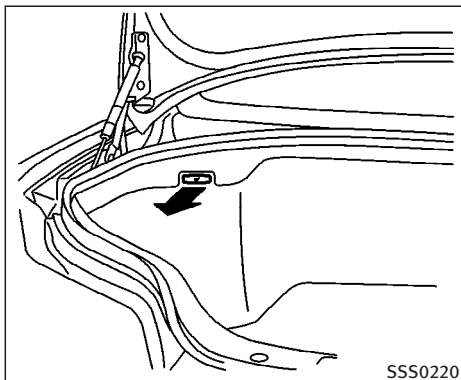

Coupe:

The rear seatback can be folded to allow access to the trunk from the inside of the vehicle.

To access the trunk:

1. Open the trunk lid.
2. Pull the handle located on the left side of the trunk. The rear seatback will be unlatched.
3. Fold the rear seatback down.

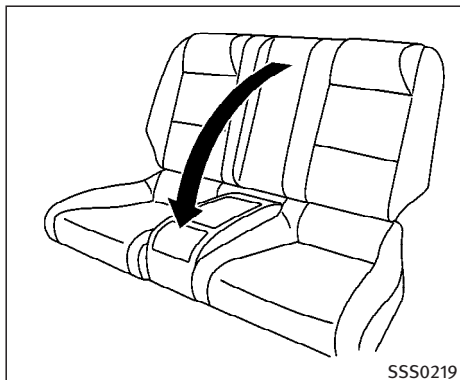

WARNING

Properly secure all cargo to help prevent it from sliding or shifting. Do not place cargo higher than the seatbacks. In a sudden stop or collision, unsecured cargo could cause personal injury.

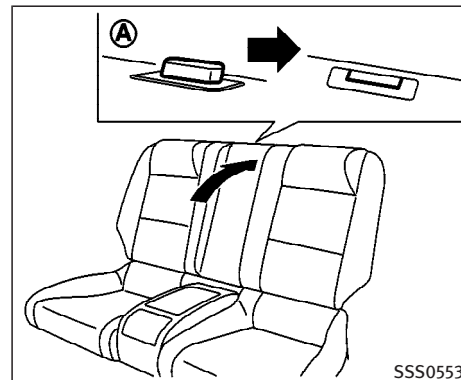

To return the seatback:

1. Fold up the rear seatback.
2. Securely lock the seatback in position.

When the seatback is latched, the seat lock indicator **A** on the seatback will be lowered.

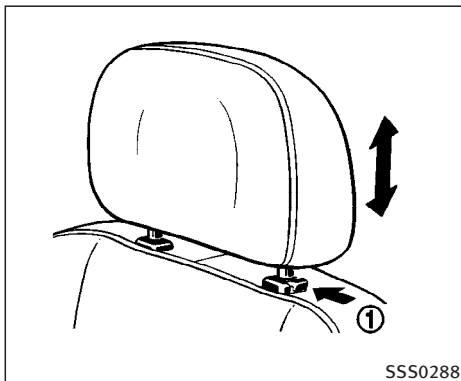

HEAD RESTRAINT ADJUSTMENT

To raise the head restraint, just pull it up. To lower, push the lock knob ① and push the head restraint down.

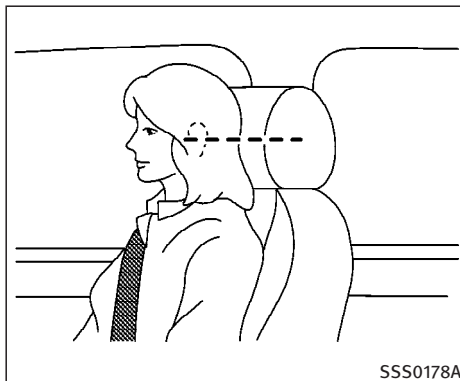

Adjust the head restraints so the center is level with the center of your ears.



WARNING

Head restraints should be adjusted properly as they may provide significant protection against injury in an accident. Do not remove them. Check the adjustment after someone else uses the seat.

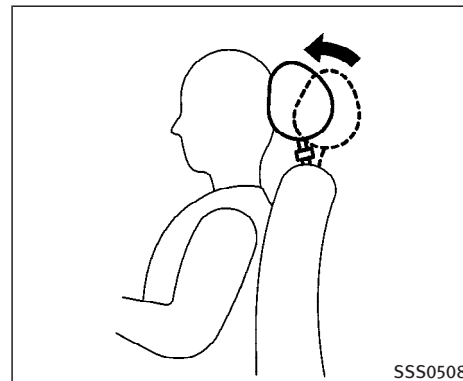

ACTIVE HEAD RESTRAINT (front seats)



WARNING

- Always adjust the head restraints properly as specified in the previous section. Failure to do so can reduce the effectiveness of the active head restraint.
- Active head restraints are designed to supplement other safety systems. Always wear seat belts. No system can

prevent all injuries in any accident.

- Do not attach anything to the head restraint stalks. Doing so could impair active head restraint function.

The active head restraint moves forward utilizing the force that the seatback receives from the occupant in a rear-end collision. The movement of the head restraint helps support the occupant's head by reducing its backward movement and helping absorb some of the forces that may lead to whiplash type injuries.

Active head restraints are effective for collisions at low to medium speeds in which it is said that whiplash injury occurs most.

Active head restraints operate only in certain rear-end collisions. After the collision, the head restraints return to their original positions.

Properly adjust the active head restraints as described in the previous section.

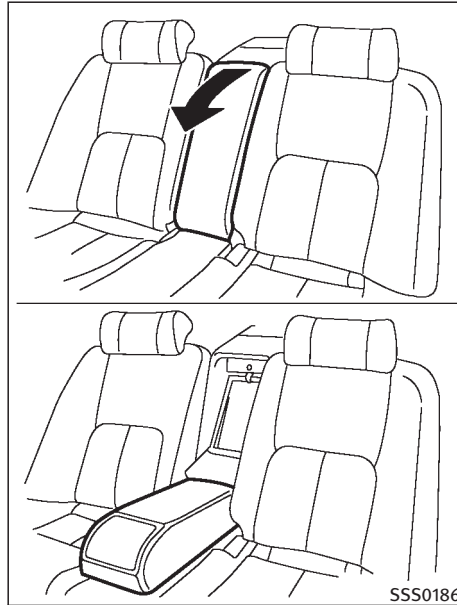

ARMREST (if so equipped)

Pull the armrest forward until it is horizontal.

SEAT BELTS

PRECAUTIONS ON SEAT BELT USAGE

If you are wearing your seat belt properly adjusted, and you are sitting upright and well back in your seat, your chances of being injured or killed in an accident and/or the severity of injury may be greatly reduced. INFINITI strongly encourages you and all of your passengers to buckle up every time you drive, even if your seating position includes a supplemental air bag.

Most states, provinces or territories require that seat belts be worn at all times when a vehicle is being driven.

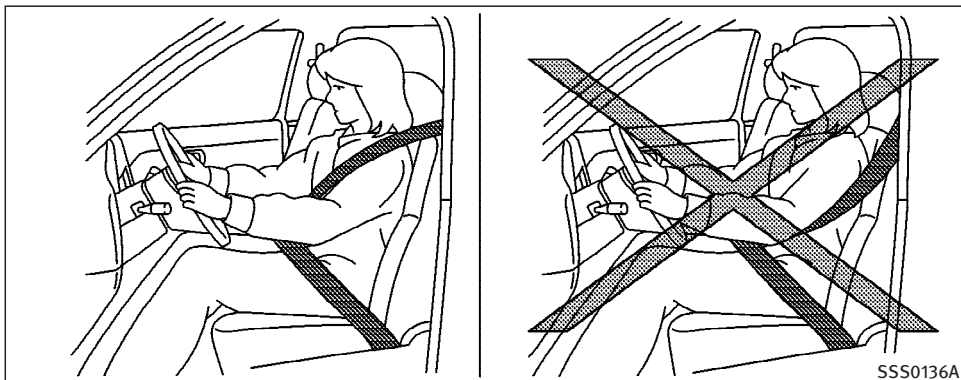

WARNING

- Every person who drives or rides in this vehicle should use a seat belt at all times. Children should be properly restrained in the rear seat and, if appropriate, in a child restraint.
- The seat belt should be properly adjusted to a snug fit. Failure to do so may reduce the effectiveness of the entire restraint system and increase the

chance or severity of injury in an accident. Serious injury or death can occur if the seat belt is not worn properly.

- Always route the shoulder belt over your shoulder and across your chest. Never run the belt behind your back, under your arm or across your neck. The belt should be away from your face and neck, but not falling off your shoulder.

- Position the lap belt as low and snug as possible around the hips, not the waist. A lap belt worn too high could increase the risk of internal injuries in an accident.
- Be sure the seat belt tongue is securely fastened to the proper buckle.
- Do not wear the seat belt inside out or twisted. Doing so may reduce its effectiveness.
- Do not allow more than one person to use the same seat belt.
- Never carry more people in the vehicle than there are seat belts.
- If the seat belt warning light glows continuously while the ignition is turned ON with all doors closed and all seat belts fastened, it may indicate a malfunction in the system. Have the system checked by an INFINITI dealer.
- Once the pre-tensioner seat belt has activated, it cannot be reused and must be replaced together with the retractor. See an INFINITI dealer.

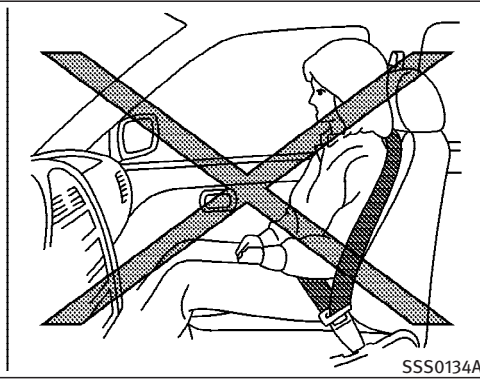
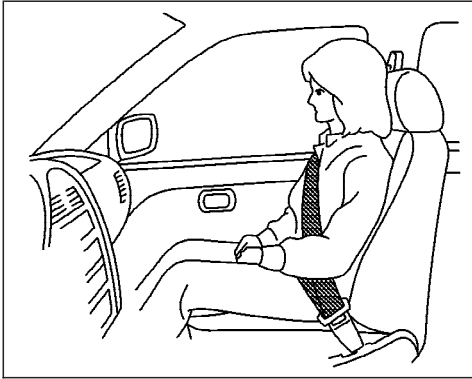

SSS0134A

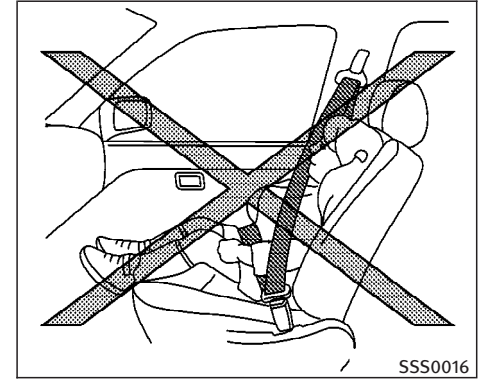

SSS0016

- Removal and installation of the pretensioner seat belt system components should be done by an INFINITI dealer.
- All seat belt assemblies, including retractors and attaching hardware, should be inspected after any collision by an INFINITI dealer. INFINITI recommends that all seat belt assemblies in use during a collision be replaced unless the collision was minor and the belts show no damage and continue to operate properly. Seat belt assemblies not in

use during a collision should also be inspected and replaced if either damage or improper operation is noted.

- All child restraints and attaching hardware should be inspected after any collision. Always follow the restraint manufacturer's inspection instructions and replacement recommendations. The child restraints should be replaced if they are damaged.

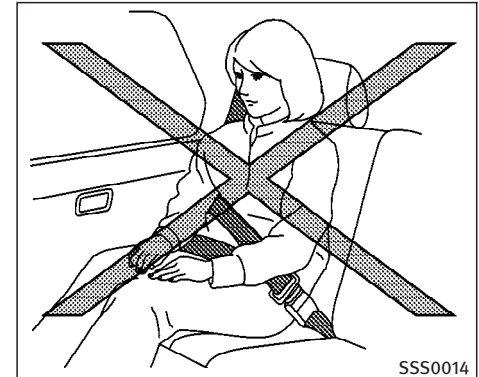

SSS0014

CHILD SAFETY

Children need adults to help protect them. They need to be properly restrained.

In addition to the general information in this manual, child safety information is available from many other sources, including doctors, teachers, government traffic safety offices, and community organizations. Every child is different, so be sure to learn the best way to transport your child.

There are three basic types of child restraint systems:

- Rear-facing child restraint
- Front-facing child restraint
- Booster seat

The proper restraint depends on the child's size. Generally, infants (up to about 1 year and less than 20 lb (9 kg)) should be placed in rear-facing child restraints. Front-facing child restraints are available for children who outgrow rear-facing child restraints and are at least 1 year old. Booster seats are used to help position a vehicle lap/shoulder belt on a child who can no longer use a front-facing child restraint.

1-12 Safety — Seats, seat belts and supplemental restraint system



WARNING

Infants and children need special protection. The vehicle's seat belts may not fit them properly. The shoulder belt may come too close to the face or neck. The lap belt may not fit over their small hip bones. In an accident, an improperly fitting seat belt could cause serious or fatal injury. Always use appropriate child restraints.

All US states and provinces of Canada require the use of approved child restraints for infants and small children. (See “Child restraints” later in this section.)

Also, there are other types of child restraints available for larger children for additional protection.

INFINITI recommends that all pre-teens and children be restrained in the rear seat if possible. According to accident statistics, children are safer when properly restrained in the rear seat than in the front seat.

This is especially important because your vehicle has a supplemental restraint system (air bag system) for the front pas-

senger. See “Supplemental Restraint System” later in this section for precautions.

Infants

Infants up to at least 1 year old should be placed in a rear-facing child restraint. INFINITI recommends that infants be placed in child restraints that comply with Federal Motor Vehicle Safety Standards or Canadian Motor Vehicle Safety Standards. You should choose a child restraint that fits your vehicle and always follow the manufacturer's instructions for installation and use.

Small children

Children that are over 1 year old and weigh between 20 lb (9 kg) and 40 lb (18 kg) can be placed in a forward facing child restraint. Refer to the manufacturer's instructions for minimum and maximum weight and height recommendations. INFINITI recommends that small children be placed in child restraints that comply with Federal Motor Vehicle Safety Standards or Canadian Motor Vehicle Safety Standards. You should choose a child restraint that fits your vehicle and always follow the manufacturer's instructions for installation and use.

Larger children

Children who are too large for child restraints should be seated and restrained by the seat belts which are provided. The seat belt may not fit properly if the child is less than 4 feet 9 inches (142.5 cm) tall and weighs between 40 lb (18 kg) and 80 lb (36 kg). A booster seat should be used to obtain proper seat belt fit.

INFINITI recommends that a child be placed in a commercially available booster seat if the shoulder belt in the child's seating position fits close to the face or neck or if the lap portion of the seat belt goes across the abdomen. The booster seat should raise the child so that the shoulder belt is properly positioned across the top, middle portion of the shoulder and the lap belt is low on the hips. A booster seat can only be used in seating positions that have a three-point type seat belt. The booster seat should fit the vehicle seat and have a label certifying that it complies with Federal Motor Vehicle Safety Standards or Canadian Motor Vehicle Safety Standards. Once the child has grown so the shoulder belt is no longer on or near the face and neck, use the shoulder belt without the booster seat.



WARNING

Never let a child stand or kneel on any seat and do not allow a child in the cargo areas while the vehicle is moving. The child could be seriously injured or killed in an accident or sudden stop.

PREGNANT WOMEN

INFINITI recommends that pregnant women use seat belts. The seat belt should be worn snug, and always position the lap belt as low as possible around the hips, not the waist. Place the shoulder belt over your shoulder and across your chest. Never run the lap/shoulder belt over your abdominal area. Contact your doctor for specific recommendations.

INJURED PERSONS

INFINITI recommends that injured persons use seat belts, depending on the injury. Check with your doctor for specific recommendations.

THREE-POINT TYPE SEAT BELT WITH RETRACTOR



WARNING

- Every person who drives or rides in this vehicle should use a seat belt at all times.
- Do not ride in a moving vehicle when the seatback is reclined. This can be dangerous. The shoulder belt will not be against your body. In an accident, you could be thrown into it and receive neck or other serious injuries. You could also slide under the lap belt and receive serious internal injuries.
- For the most effective protection when the vehicle is in motion, the seat should be upright. Always sit well back in the seat and adjust the seat belt properly.

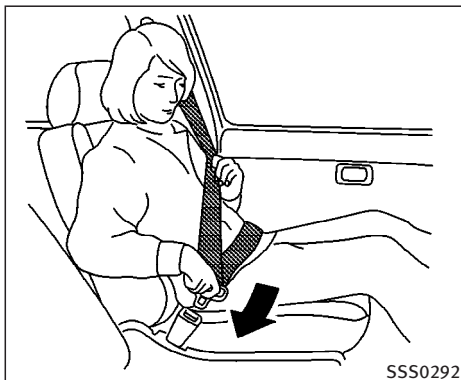

Front seat

Fastening the seat belts

1. Adjust the seat. See “Seats” earlier in this section.
2. Slowly pull the seat belt out of the retractor and insert the tongue into the buckle until it clicks.
 - **The retractor is designed to lock during a sudden stop or on impact. A slow pulling motion will permit the belt to move, and allow you some freedom of movement in the seat.**



Rear seat

- **If the seat belt cannot be pulled from its fully retracted position, firmly pull the belt and release it. Then smoothly pull the belt out of the retractor.**

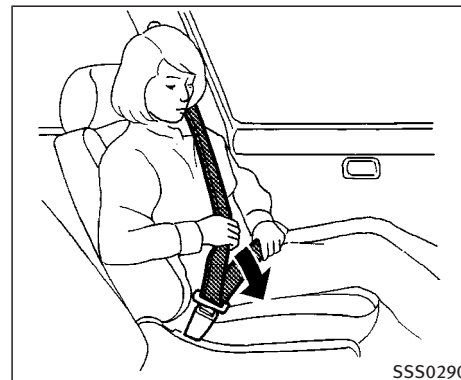

Front seat

3. Position the lap belt portion **low and snug on the hips** as shown.
4. Pull the shoulder belt portion toward the retractor to take up extra slack. Be sure the shoulder belt is routed over your shoulder and across your chest.

The front passenger and rear seat belts have a locking mechanism for child restraint installation. It is referred to as the automatic locking mode.

When the locking mechanism is activated the seat belt cannot be extended again until the seat belt tongue is detached

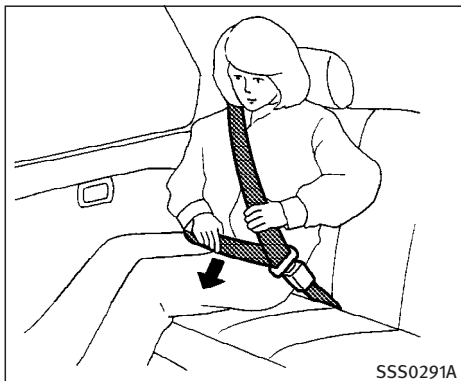

SSS0291A

Rear seat

from the buckle and fully retracted. For additional information, see “Child restraints” later in this section.

The automatic locking mode should be used only for child restraint installation. During normal seat belt use by a passenger, the locking mode should not be activated. If it is activated it may cause uncomfortable seat belt tension. It can also change the operation of the front passenger air bag. See “Front passenger air bag and status light” later in this section.



WARNING

When fastening the seat belts, be certain that the seatbacks are completely secured in the latched position. If they are not completely secured, passengers may be injured in an accident or sudden stop.

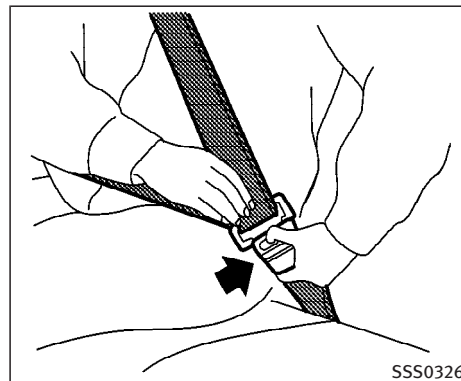

SSS0326

Unfastening the seat belts

To unfasten the belt, push the button on the buckle. The seat belt will automatically retract.

Checking seat belt operation

Your seat belt retractors are designed to lock belt movement using two separate methods:

- when the belt is pulled quickly from the retractor.
- when the vehicle slows down rapidly.

You can check their operation as follows:

- grasp the shoulder belt and pull forward quickly. The retractor should lock and restrict further belt movement.

If the retractor does not lock during this check or if you have any questions about belt operation, see an INFINITI dealer.

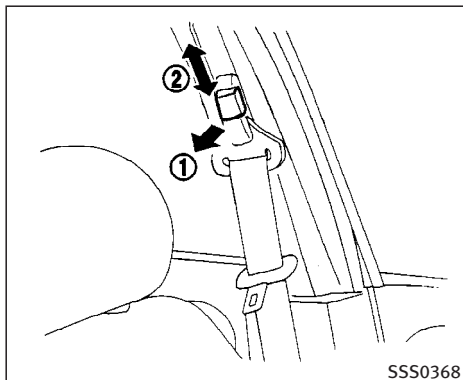

Shoulder belt height adjustment (for Sedan front seats)

The shoulder belt anchor height should be adjusted to the position best suited for you. (See “Precautions on seat belt usage” earlier in this section.) To adjust, pull the release button ①, and then move the shoulder belt anchor ② to the desired position, so that the belt passes over the center of the shoulder. The belt should be away from your face and neck, but not falling off of your shoulder. Release the adjustment button ① to lock the shoulder belt anchor into position.



WARNING

- After adjustment, release the adjustment button and try to move the shoulder belt anchor up and down to make sure it is securely fixed in position.
- The shoulder belt anchor height should be adjusted to the position best for you. Failure to do so may reduce the effectiveness of the entire restraint system and increase the chance or severity of injury in an accident.

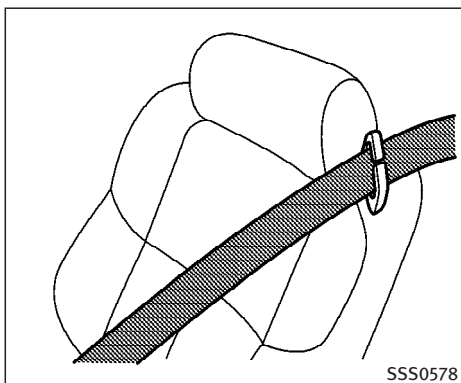

Shoulder belt guide (Coupe)

The shoulder belt guides are attached on the shoulders of the front seats to help front occupants use the seat belts.

To use the shoulder belt guides, thread the seat belt into the slot of the guide.

When you enter or exit the rear seat, release the seat belt from the shoulder belt guide. Replace the seat belt in the guide after rear seat access.

Always adjust the seat belt webbing snugly. The shoulder belt guide can also help assist proper fit and comfort. Always

make sure that the belt webbing is not twisted and runs freely through the guide when using it.



WARNING

Always route the shoulder belt over your shoulder and across your chest. Never run the belt behind your back, under your arm or across your neck. The belt should be away from your face and neck, but not falling off your shoulder. Use the shoulder belt guide to help position the belt. Failure to properly position the belt may reduce the effectiveness of the entire restraint system and increase the chance or severity of injury in an accident.

SEAT BELT EXTENDERS

If, because of body size or driving position, it is not possible to properly fit the lap-shoulder belt and fasten it, an extender is available. The extender adds approximately 8 inches (200 mm) of length and may be used for either the driver or front passenger seating position. See an INFINITI dealer for assistance if the extender is required.



WARNING

- Only INFINITI seat belt extenders, made by the same company which made the original equipment seat belts, should be used with INFINITI seat belts.
- Adults and children who can use the standard seat belt should not use an extender. Such unnecessary use could result in serious personal injury in the event of an accident.
- Never use seat belt extenders to install child restraints. If the child restraint is not secured properly, the child could be seriously injured in a collision or a sudden stop.

SEAT BELT MAINTENANCE

- To clean the seat belt webbings, apply a mild soap solution or any solution recommended for cleaning upholstery or carpets. Then brush the seat belt webbing, wipe it with a cloth and allow it to dry in the shade. Do not allow the seat belts to retract until they are completely dry.

CHILD RESTRAINTS

- If dirt builds up in the shoulder belt guide of the seat belt anchors, the seat belts may retract slowly. Wipe the shoulder belt guide with a clean, dry cloth.
- **Periodically check that the seat belt and all the metal components**, such as buckles, tongues, retractors, flexible wires and anchors, work properly. If loose parts, deterioration, cuts or other damage on the seat belt webbing is found, the entire belt assembly should be replaced.

PRECAUTIONS ON CHILD RESTRAINTS



WARNING

- **Infants and small children should always be placed in an appropriate child restraint while riding in the vehicle. Failure to use a child restraint can result in serious injury or death.**
- **Infants and small children should never be carried on your lap. It is not possible for even the strongest adult to resist the forces of a severe accident. The child could be crushed between the adult and parts of the vehicle. Also, do not put the same seat belt around both your child and yourself.**
- **Never install a rear-facing child restraint in the front seat. An inflating supplemental air bag could seriously injure or kill your child. A rear-facing child restraint must only be used in the rear seat.**

- **INFINITI recommends that the child restraint be installed in the rear seat. According to accident statistics, children are safer when properly restrained in the rear seat than in the front seat.**
- **An improperly installed child restraint could lead to serious injury or death in an accident.**

In general, child restraints are designed to be installed with the lap portion of a lap/shoulder seat belt. In addition, this vehicle is equipped with a universal child restraint lower anchor system, referred to as the LATCH (Lower Anchors and Tethers for Children) system. Some child restraints include two rigid or webbing-mounted attachments that can be connected to these lower anchors. For details, see “LATCH (Lower Anchors and Tethers for Children) SYSTEM” later in this section.

Child restraints for infants and children of various sizes are offered by several manufacturers. When selecting any child restraint, keep the following points in mind:

- Choose only a restraint with a label certifying that it complies with Federal

Motor Vehicle Safety Standard 213 or Canadian Motor Vehicle Safety Standard 213.

- Check the child restraint in your vehicle to be sure it is compatible with the vehicle's seat and seat belt system.
- If the child restraint is compatible with your vehicle, place your child in the child restraint and check the various adjustments to be sure the child restraint is compatible with your child. Choose a child restraint that is designed for your child's height and weight. Always follow all recommended procedures.

All US states and Canadian provinces require that infants and small children be restrained in approved child restraints at all times while the vehicle is being operated.



WARNING

- Improper use of a child restraint can increase the risk or severity of injury for both the child and other occupants of the vehicle.

- Follow all of the child restraint manufacturer's instructions for installation and use. When purchasing a child restraint, be sure to select one which will fit your child and vehicle. It may not be possible to properly install some types of child restraints in your vehicle.
- If the child restraint is not anchored properly, the risk of a child being injured in a collision or a sudden stop greatly increases.
- Adjustable seatbacks should be positioned to fit the child restraint, but as upright as possible.
- After attaching the child restraint, test it before you place the child in it. Push it from side to side. Try to tug it forward and check to see if the belt holds the restraint in place. The child restraint should not move more than 1 in (25 mm). If the restraint is not secure, tighten the belt as necessary, or put the restraint in another seat and test it again. You may need to try a different child restraint. Not all child restraints fit in all types of vehicles.

- If you must install a front-facing child restraint in the front seat, see "Child restraint installation on front passenger seat" later in this section.
- When your child restraint is not in use, keep it secured with a seat belt to prevent it from being thrown around in case of a sudden stop or accident.



CAUTION

Remember that a child restraint left in a closed vehicle can become very hot. Check the seating surface and buckles before placing your child in the child restraint.

CHILD RESTRAINT INSTALLATION ON REAR SEAT OUTBOARD OR CENTER POSITIONS

WARNING

- The three-point seat belt in your vehicle is equipped with an automatic locking mode retractor which must be used when installing a child restraint.
- Failure to use the automatic locking mode will result in the child restraint not being properly secured. The restraint could tip over or otherwise be unsecured and cause injury to the child in a sudden stop or collision.

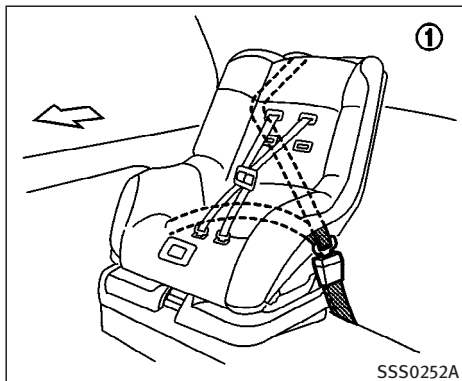

Rear outboard seat

Front facing

When you install a child restraint in a rear outboard or center seat, follow these steps:

1. Position the child restraint on the seat. Always follow the restraint manufacturer's instructions.

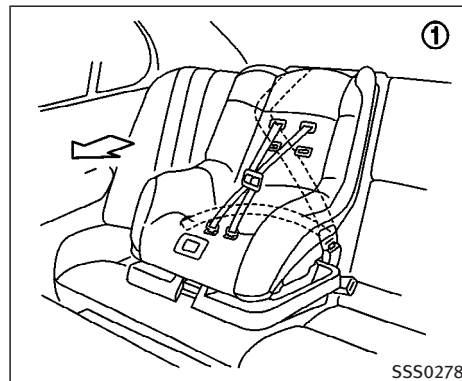

Rear center seat

The back of the child restraint should be secured against the vehicle seatback. If necessary, adjust or remove the head restraint to obtain the correct child restraint fit. See “Head restraint adjustment” earlier in this section. If the head restraint is removed, store it in a secure place. Be sure to install the head restraint when the child restraint is removed. If the seating position does not have an adjustable head restraint and it is interfering with the proper child restraint fit, try another seating position or a different child restraint.

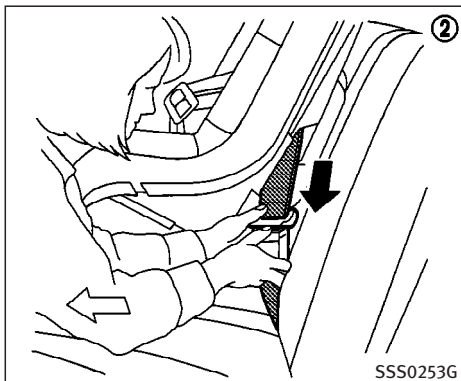

2. Route the seat belt tongue through the child restraint and insert it into the buckle until you hear and feel the latch engage. Be sure to follow the child restraint manufacturer's instructions for belt routing.

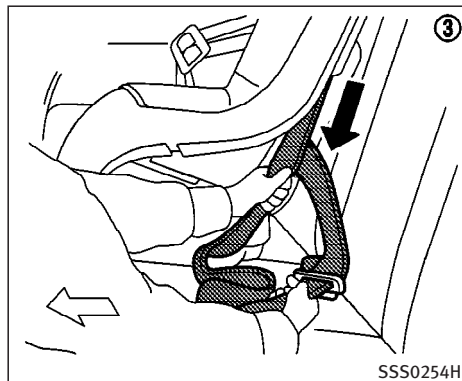

3. Pull on the shoulder belt until all of the belt is fully extended. At this time, the belt retractor is in the automatic locking mode (child restraint mode). It reverts back to emergency locking mode when the belt is fully retracted.

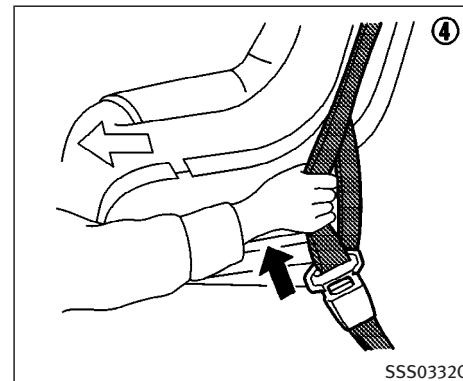

4. Allow the belt to retract. Pull up on the belt to remove any slack in the belt.

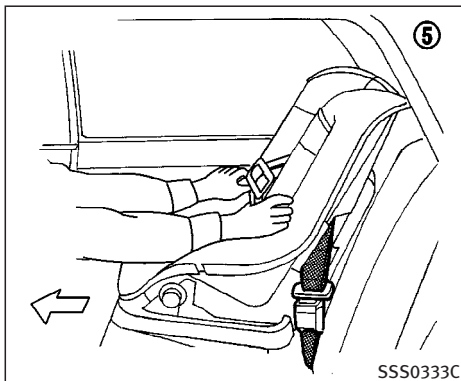

5. Before placing the child in the child restraint, use force to push the child restraint from side to side, and tug it forward to make sure that it is securely held in place. It should not move more than 1 in (25 mm). If it does move more than 1 in (25 mm), pull again on the shoulder belt to further tighten the child restraint. If unable to properly secure the restraint, move the restraint to another rear seating position and try again, or try a different child restraint. Not all child restraints fit in all types of vehicles.

6. Check that the retractor is in the automatic locking mode by trying to pull more belt out of the retractor. If you cannot pull any more belt webbing out of the retractor, the belt is in the automatic locking mode.
7. Check to make sure that the child restraint is properly secured prior to each use. If the belt is not locked, repeat steps 3 through 6.

After the child restraint is removed and the seat belt is fully retracted, the automatic locking mode (child restraint mode) is canceled.

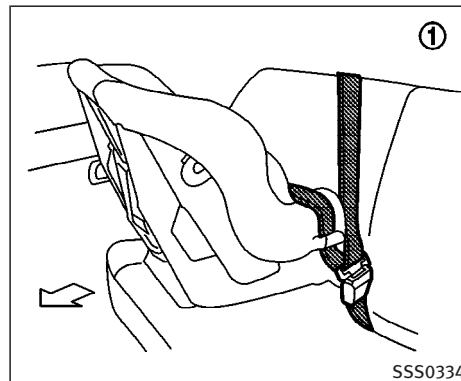

Rear outboard seat

Rear facing

When you install a child restraint in a rear outboard or center seat, follow these steps:

1. Position the child restraint on the seat. Always follow the restraint manufacturer's instructions.

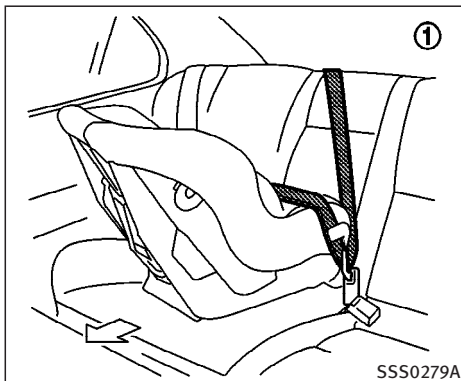

Rear center seat

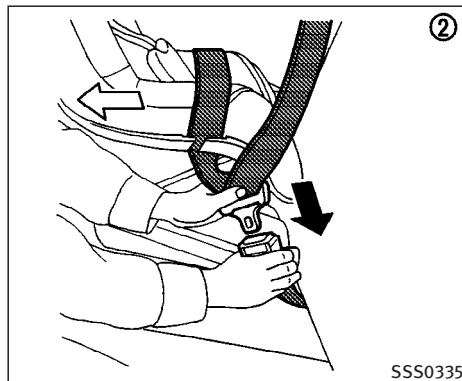

2. Route the seat belt tongue through the child restraint and insert it into the buckle until you hear and feel the latch engage. Be sure to follow the child restraint manufacturer's instructions for belt routing.

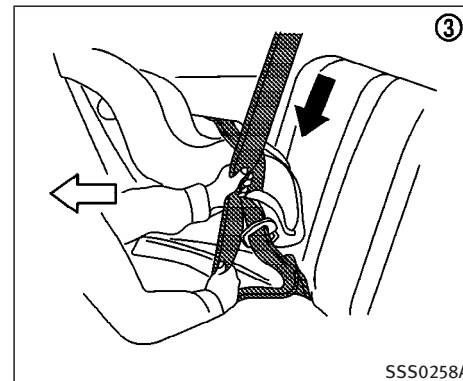

3. Pull on the shoulder belt until all of the belt is fully extended. At this time, the belt retractor is in the automatic locking mode (child restraint mode). It reverts back to emergency locking mode when the belt is fully retracted.

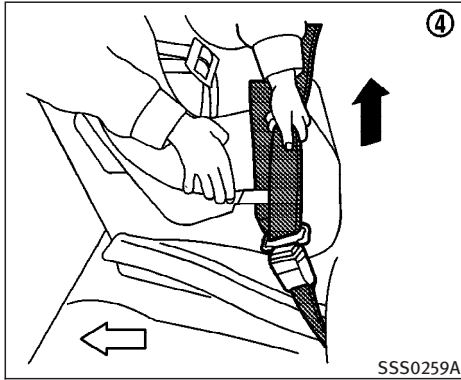

4. Allow the belt to retract. Pull up the belt to remove any slack in the belt.

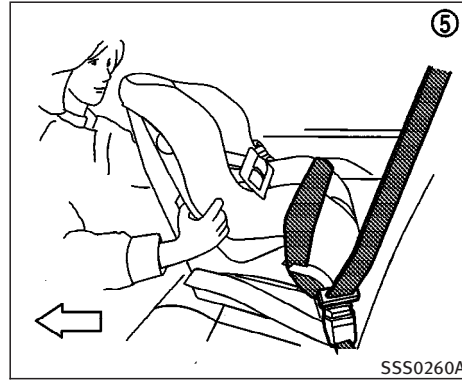

5. Before placing the child in the child restraint, use force to push the child restraint from side to side, and tug it forward to make sure that it is securely held in place. It should not move more than 1 in (25 mm). If it does move more than 1 in (25 mm), pull again on the shoulder belt to further tighten the child restraint. If unable to properly secure the restraint, move the restraint to another rear seating position and try again, or try a different child restraint. Not all child restraints fit in all types of vehicles.

6. Check that the retractor is in the automatic locking mode by trying to pull more belt out of the retractor. If you cannot pull any more belt webbing out of the retractor, the belt is in the automatic locking mode.
7. Check to make sure that the child restraint is properly secured prior to each use. If the belt is not locked, repeat steps 3 through 6.

After the child restraint is removed and the seat belt is fully retracted, the automatic locking mode (child restraint mode) is canceled.

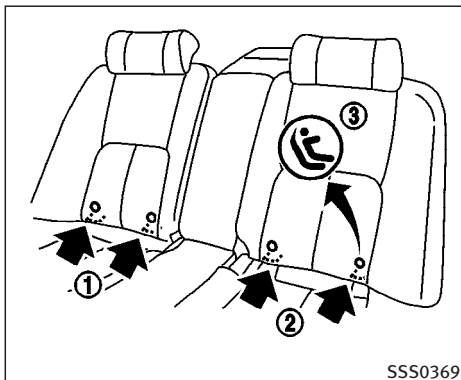

Sedan

LATCH (Lower Anchors and Tethers for Children) SYSTEM

1. LATCH lower anchor points (right)
2. LATCH lower anchor points (left)
3. LATCH label

The LATCH (Lower Anchors and Tethers for Children) anchor points are located in the seat cushions of the rear outboard seating positions only. Do not attempt to install a child restraint in the center position using the LATCH anchors.

The LATCH system anchors are located at the rear of the seat cushion near the seatback. A label is attached to the seatback to help you locate the LATCH system anchors.

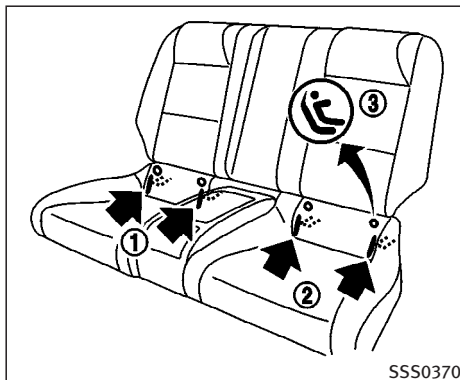

Coupe



WARNING

- Attach LATCH system compatible child restraints only at the locations shown. If a child restraint is not secured properly, your child could be seriously injured or killed in an accident.
- Do not secure a child restraint in the center rear seating position using the LATCH system anchors. The child restraint will not be secured properly.

- The LATCH system anchors are designed to withstand only those loads imposed by correctly fitted child restraints. Under no circumstance are they to be used for adult seat belts or harnesses.

Some child restraints include two rigid or webbing-mounted attachments that can be connected to two anchors located at certain seating positions in your vehicle. This system is known as the LATCH system. This system may also be referred to as the ISOFIX or ISOFIX compatible system. With this system, you do not have to use a vehicle seat belt to secure the child restraint. Your vehicle is equipped with special anchor points that are used with LATCH system compatible child restraints. Check your child restraint for a label stating that it is compatible with the LATCH system. This information may also be in the instructions provided by the child restraint manufacturer. If you have such a child restraint, refer to the illustration for the rear seating positions equipped with LATCH system anchors which can be used to secure the child restraint.

Some child restraints may also require the use of a top tether strap. See “Top tether strap child restraint” later in this section for installation instructions.

When installing a child restraint, carefully read and follow the instructions in this manual and those supplied with the child restraint.

When you install a LATCH system compatible child restraint to the lower anchor attachments in the rear seat, follow these steps.



WARNING

Inspect the lower anchors by inserting your fingers into the lower anchor area and feeling to make sure there are no obstructions over the LATCH system anchors, such as seat belt webbing or seat cushion material. The child restraint will not be secured properly if the LATCH system anchors are obstructed.

1. To install the LATCH system compatible child restraint, adjust the height of the child restraint LATCH system an-

chor attachments to the anchor points on the rear seat.

2. Insert the anchor attachments into the anchor points. If the child restraint is equipped with a top tether, see “Top tether strap child restraint” later in this section for installation instructions.
3. After attaching the child restraint and before placing the child in it, use force to push the child restraint from side to side and tug it forward to make sure that the child restraint is securely held in place. It should not move more than 1 in (25 mm).
4. Check to make sure that the child restraint is properly secured prior to each use.

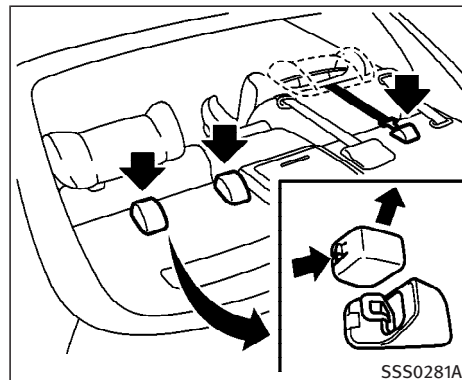

Sedan

TOP TETHER STRAP CHILD RESTRAINT



WARNING

- Child restraint anchor points are designed to withstand only those loads imposed by correctly fitted child restraints. Under no circumstance are they to be used for adult seat belts or harnesses.

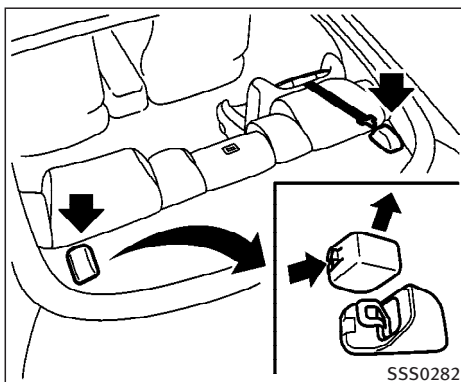

Coupe

SSS0282

- **After removing a rear seat head restraint for top tether installation, store it securely to prevent it from causing injury to passengers or damage to the vehicle in case of sudden braking or an accident. Always replace it and adjust properly when top tether is no longer in use.**

If your child restraint has a top tether strap, it must be secured to the anchor point provided behind its position.

First, adjust the seatback so that it is upright (if so equipped). Remove the anchor cover from the anchor point as illustrated. Keep the removed cover in a secure place to prevent loss or damage. Then secure the child restraint with the rear seat belt or the LATCH system (outboard positions), as applicable.

Remove the head restraint from the seatback, if equipped with an adjustable rear head restraint. Store it in a secure place. Position the top tether strap over the top of the seatback and secure it to the tether anchorage that provides the straightest installation. Tighten the tether strap according to the manufacturer's instruction to remove any slack.

For best child restraint fit, see the child restraint installation instructions in this section and the child restraint manufacturer's instructions.

Anchor point locations

Anchor points are located on the rear parcel shelf finisher.

If you have any questions when installing a top strap child restraint on the rear seat, consult an INFINITI dealer for details.

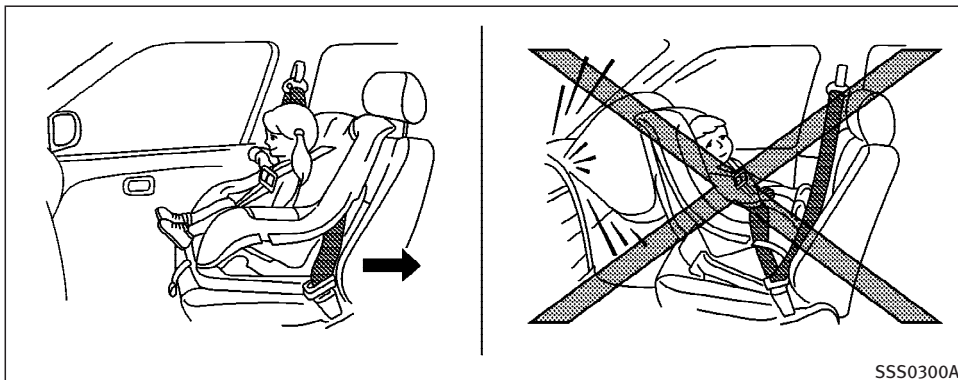

CHILD RESTRAINT INSTALLATION ON FRONT PASSENGER SEAT

WARNING

- Never install a rear-facing child restraint in the front passenger seat. Supplemental front air bags inflate with great force. A rear-facing child restraint could be struck by the supplemental front air bag in a crash and could seriously injure or kill your child.

- INFINITI recommends that child restraints be installed in the rear seat. However, if you must install a front-facing child restraint in the front passenger seat, move the passenger seat to the rearmost position. Also, be sure the front passenger air bag status light is illuminated to indicate the passenger air bag is OFF. See “Front passenger air bag and status light” later in this section for details.

- A child restraint with a top tether strap should not be used in the front passenger seat.
- The three-point seat belt in your vehicle is equipped with an automatic locking mode retractor which must be used when installing a child restraint.
- Failure to use the retractor’s locking mode will result in the child restraint not being properly secured. The restraint could tip over or otherwise be unsecured and cause injury to the child in a sudden stop or collision. Also, it can change the operation of the front passenger air bag. See “Front passenger air bag and status light” later in this section.

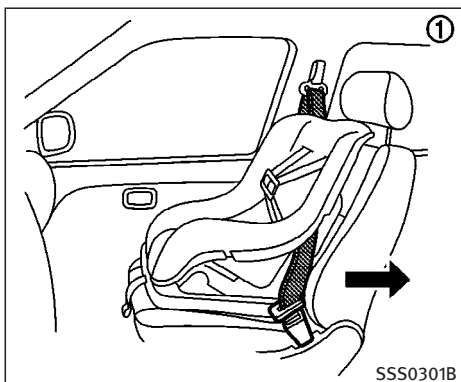

Front facing

If you must install a child restraint in the front seat, follow these steps:

1. Position the child restraint on the front passenger seat. **It should be placed in a front-facing direction only.** Move the seat to the rearmost position. Adjust the head restraint to its highest position. Always follow the child restraint manufacturer's instructions. **Child restraints for infants must be used in the rear-facing direction and therefore must not be used in the front seat.**

The back of the child restraint should be secured against the vehicle seat-back. If necessary, adjust or remove the head restraint to obtain the correct child restraint fit. See "Head restraint adjustment" earlier in this section.

If the head restraint is removed, store it in a secure place. Be sure to install the head restraint when the child restraint is removed.

If the seating position does not have an adjustable head restraint and it is interfering with the proper child restraint fit, try another seating position or a different child restraint.

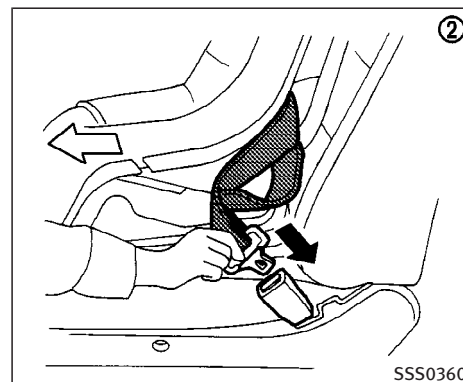

2. Route the seat belt tongue through the child restraint and insert it into the buckle until you hear and feel the latch engage. Be sure to follow the child restraint manufacturer's instructions for belt routing.

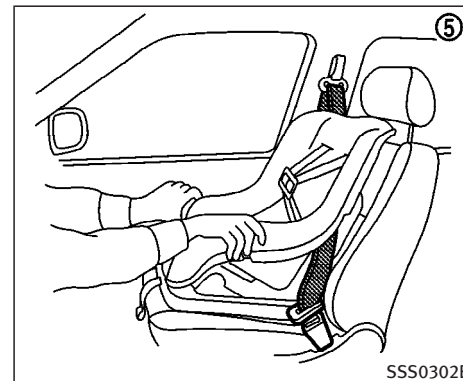
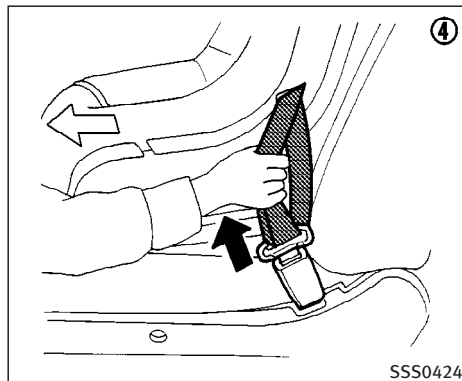
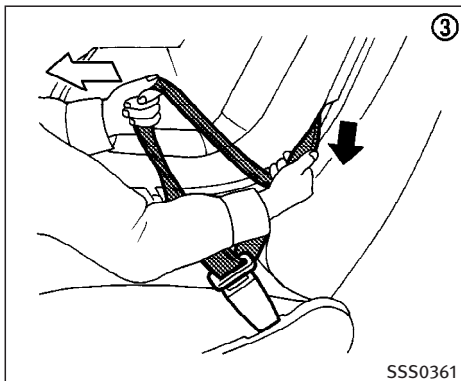

3. Pull on the shoulder belt until all of the belt is fully extended. At this time, the belt retractor is in the automatic locking mode (child restraint mode). It reverts back to emergency locking mode when the belt is fully retracted.
4. Allow the seat belt to retract. Pull up the shoulder belt to remove any slack in the belt.
5. Before placing the child in the child restraint, use force to push the child restraint from side to side, and tug it forward to make sure that it is securely held in place. It should not move more than 1 inch (25 mm). If it does move more than 1 inch (25 mm), pull again on the shoulder belt to further tighten the child restraint. If unable to properly secure the restraint, move the restraint to another rear seating position and try again, or try a different child restraint. Not all child restraints fit in all types of vehicles.

BOOSTER SEATS

6. Check that the retractor is in the automatic locking mode by trying to pull more belt out of the retractor. If you cannot pull any more belt webbing out of the retractor, the retractor is in the automatic locking mode.
7. Check to make sure that the child restraint is properly secured prior to each use. If the seat belt is not locked, repeat steps 3 through 7.
8. Turn the ignition switch to the ON position. The passenger air bag status light  should illuminate. If this light is not illuminated, see “Front passenger air bag and status light” later in this section. **Move the child restraint to another seating position.** Have the system checked by an INFINITI dealer.

After the child restraint is removed and the seat belt is fully retracted, the automatic locking mode (child restraint mode) will be canceled.

PRECAUTIONS ON BOOSTER SEATS



WARNING

- **Infants and small children should always be placed in an appropriate child restraint while riding in the vehicle. Failure to use a child restraint or booster seat can result in serious injury or death.**
- **Infants and small children should never be carried on your lap. It is not possible for even the strongest adult to resist the forces of a severe accident. The child could be crushed between the adult and parts of the vehicle. Also, do not put the same seat belt around both your child and yourself.**
- **INFINITI recommends that the booster seat be installed in the rear seat. According to accident statistics, children are safer when properly restrained in the rear seat than in the front seat.**
- **A booster seat must only be installed in a seating position that has a lap/shoulder belt. Failure to use a three-**

point type seat belt with a booster seat can result in a serious injury in sudden stop or collision.

- **An improperly installed booster seat could lead to serious injury or death in an accident.**

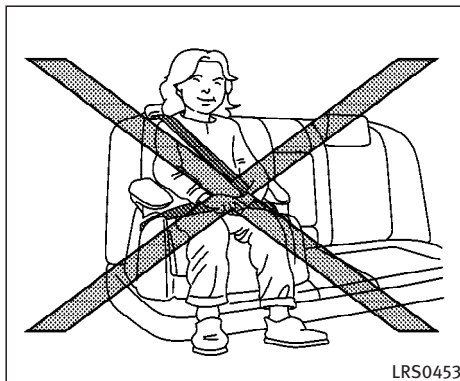
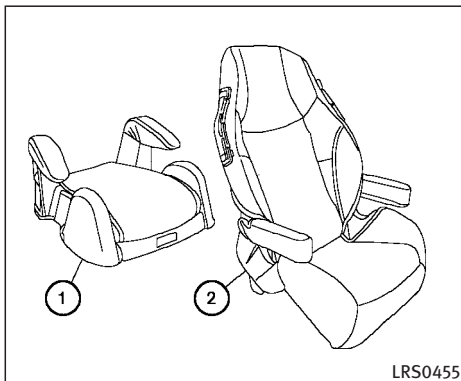

WARNING

Do not use towels, books, pillows or other items in place of a booster seat. Items such as these may move during normal driving or a collision and result in serious injury or death. Booster seats are designed to be used with a lap/shoulder belt. Booster seats are designed to properly route the lap and shoulder portions of the seat belt over the strongest portions of a child's body to

provide the maximum protection during a collision.

Booster seats of various sizes are offered by several manufacturers. When selecting any booster seat, keep the following points in mind:

- Choose only a booster seat with a label certifying that it complies with Federal Motor Vehicle Safety Standard 213 or Canadian Motor Vehicle Safety Standard 213.
- Check the booster seat in your vehicle to be sure it is compatible with the vehicle's seat and seat belt system.

- Make sure the child's head will be properly supported by the booster seat or vehicle seat. The seatback must be at or above the center of the child's ears. For example, if a low back booster seat ① is chosen, the vehicle seatback must be at or above the center of the child's ears. If the seatback is lower than the center of the child's ears, a high back booster seat ② should be used.
- If the booster seat is compatible with your vehicle, place your child in the booster seat and check the various adjustments to be sure the booster

seat is compatible with your child. Always follow all recommended procedures.

All U.S. states and Canadian provinces or territories require that infants and small children be restrained in an approved child restraint at all times while the vehicle is being operated.



WARNING

- Improper use of a booster seat can increase the risk or severity of injury for both the child and other occupants of the vehicle.
- Follow all of the booster seat manufacturer's instructions for installation and use. When purchasing a booster seat, be sure to select one which will fit your child and vehicle. It may not be possible to properly install some types of booster seats in your vehicle.
- If the booster seat and seat belt are not used properly, the risk of a child being injured in a collision or a sudden stop greatly increases.

- Adjustable seatbacks should be positioned to fit the booster seat, but as upright as possible.
- After placing the child in the booster seat and fastening the seat belt, make sure the shoulder portion of the belt is away from the child's face and neck and the lap portion of the belt does not cross the abdomen.
- Do not put the shoulder belt behind the child or under the child's arm. If you must install a booster seat in the front seat, see "Booster seat installation on front passenger seat" later in this section.
- When your booster seat is not in use, keep it secured with a seat belt to prevent it from being thrown around in case of a sudden stop or accident.



CAUTION

Remember that a booster seat left in a closed vehicle can become very hot. Check

the seating surface and buckles before placing your child in the booster seat.



Outboard position

BOOSTER SEAT INSTALLATION ON REAR SEAT OUTBOARD OR CENTER POSITIONS



CAUTION

Do not use a lap/shoulder belt automatic locking mode when using a booster seat with the seat belts.

When you install a booster seat in the rear seat, follow these steps:

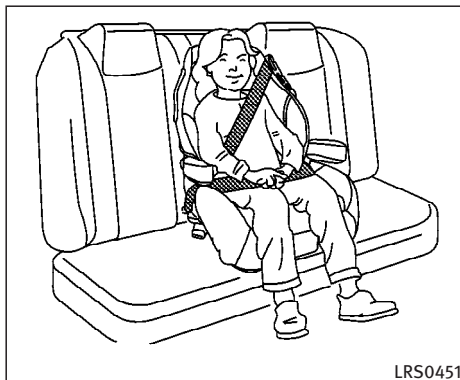

Center position

1. Position the booster seat on the seat. Only place it in a front-facing direction. Always follow the booster seat manufacturer's instructions.
2. The booster seat should be positioned on the vehicle seat so that it is stable. If necessary, adjust or remove the head restraint to obtain the correct booster seat fit. See "Head restraint adjustment" earlier in this section. If the head restraint is removed, store it in a secure place. Be sure to install the head restraint when the booster seat is removed. If the seating position does not have an adjustable head

restraint and it is interfering with the proper booster seat fit, try another seating position or a different booster seat.

3. Position the lap portion of the seat belt low and snug on the child's hips. Be sure to follow the booster seat manufacturer's instructions for adjusting the belt routing.
4. Pull the shoulder belt portion of the seat belt toward the retractor to take up extra slack. Be sure the shoulder belt is positioned across the top, middle portion of the child's shoulder. Be sure to follow the booster seat manufacturer's instructions for adjusting the belt routing.
5. Follow the warnings, cautions and instructions for properly fastening a seat belt shown in the "Three-point type seat belts with retractor" earlier in this section.

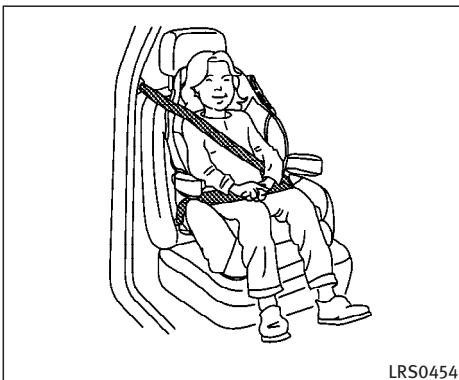

BOOSTER SEAT INSTALLATION ON FRONT PASSENGER SEAT



WARNING

INFINITI recommends that child restraints be installed in the rear seat. However, if you must install a booster seat in the front passenger seat, move the passenger seat to the rearmost position. Also be sure that the front passenger air bag status light is illuminated to indicate the passenger air bag is

OFF. See “Front passenger air bag and status light” later in this section for details.

If you must install a booster seat in the front seat, follow these steps:

1. Move the seat to the rearmost position.
2. Position the booster seat on the seat. Only place it in a front-facing direction. Always follow the booster seat manufacturer’s instructions.
3. The booster seat should be positioned on the vehicle seat so that it is stable. If necessary, adjust or remove the head restraint to obtain the correct booster seat fit. See “Head restraint adjustment” earlier in this section. If the head restraint is removed, store it in a secure place. Be sure to install the head restraint when the booster seat is removed. If the seating position does not have an adjustable head restraint and it is interfering with the proper booster seat fit, try another seating position or a different booster seat.
4. Position the lap portion of the seat belt low and snug on the child’s hips. Be sure to follow the booster seat manufacturer’s instructions for adjusting the belt routing.
5. Pull the shoulder belt portion of the seat belt toward the retractor to take up extra slack. Be sure the shoulder belt is positioned across the top, middle portion of the child’s shoulder. Be sure to follow the booster seat manufacturer’s instructions for adjusting the belt routing.
6. Follow the warnings, cautions and instructions for properly fastening a seat belt shown in the “Three-point type seat belt with retractor” earlier in this section.
7. Turn the ignition switch to the ON position. The passenger air bag status light  should illuminate. If this light is not illuminated, see “Front passenger air bag and status light” later in this section. **Move the booster seat to another seating position.** Have the system checked by an INFINITI dealer.

SUPPLEMENTAL RESTRAINT SYSTEM

PRECAUTIONS ON SUPPLEMENTAL RESTRAINT SYSTEM

This Supplemental Restraint System (SRS) section contains important information concerning the driver and passenger front impact supplemental air bags (INFINITI advanced air bag system), front seat side-impact supplemental air bags, curtain air bags and front seat pre-tensioner seat belts.

Supplemental front-impact air bag system:

The INFINITI advanced air bag system can help cushion the impact force to the head and chest of the driver and front passenger in certain frontal collisions.

Supplemental side air bag system: This system can help cushion the impact force to the chest area of the driver and front passenger in certain side impact collisions. The front seat side-impact supplemental air bags are designed to inflate on the side where the vehicle is impacted.

Supplemental curtain side-impact air bag system: This system can help cushion the impact force to the head of occupants in front and rear outboard seating positions in certain side impact collisions. The curtain side-impact air bags are designed to inflate on the side where the vehicle is impacted.

These supplemental restraint systems are designed to **supplement** the crash protection provided by the driver and passenger seat belts and are **not a substitute** for them. Seat belts should always be correctly worn and the occupant seated a suitable distance away from the steering wheel, instrument panel and door finishers. (See “Seat belts” earlier in this section for instructions and precautions on seat belt usage.)

The supplemental air bags operate only when the ignition switch is in the ON or START position.

After turning the ignition switch to the ON position, the supplemental air bag warning light illuminates. The supplemental air bag warning light will turn off after about 7 seconds if the systems are operational.

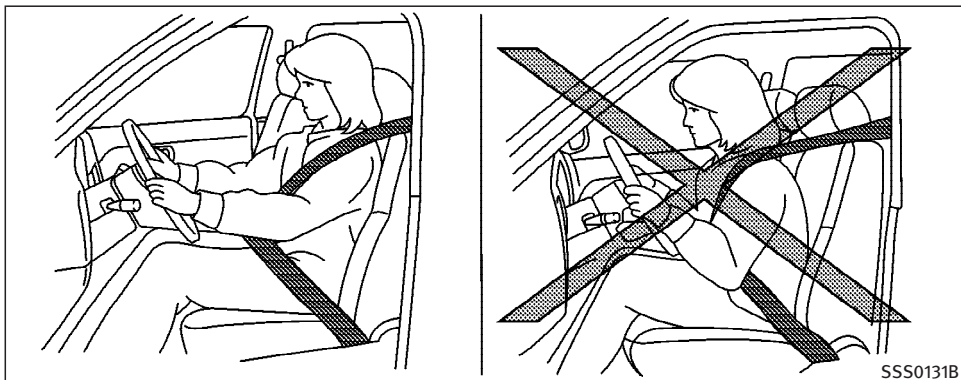

WARNING

- The supplemental front air bags ordinarily will not inflate in the event of a side impact, rear impact, rollover, or lower severity frontal collision. Always wear your seat belts to help reduce the risk or severity of injury in various kinds of accidents.
- The front passenger air bag will not inflate if the passenger air bag status light

is lit or if the front passenger seat is unoccupied. See "Front passenger air bag and status light" later in this section.

- The seat belts and the supplemental front air bags are most effective when you are sitting well back and upright in the seat. Supplemental front air bags inflate with great force. Even with the INFINITI advanced air bag system, if you are unrestrained, leaning forward, sitting sideways or out of position in any way, you are at

greater risk of injury or death in a crash. You may also receive serious or fatal injuries from the supplemental front air bag if you are up against it when it inflates. Always sit back against the seat back and as far away as practical from the steering wheel or instrument panel. Always use the seat belts.

- The driver and front passenger seat belt buckles are equipped with sensors that detect if the seat belts are fastened. The INFINITI advanced air bag system monitors the severity of a collision and seat belt usage then inflates the air bags. Failure to properly wear seat belts can increase the risk or severity of injury in an accident.
- The front passenger seat is equipped with an occupant classification sensor (pressure sensor) that turns the front passenger air bag OFF under some conditions. This sensor is only used in this seat. Failure to be properly seated and wearing the seat belt can increase the risk or severity of injury in an accident.

See “Front Passenger air bag and status light” later in this section.

- Keep hands on the outside of the steering wheel. Placing them inside the steering wheel rim could increase the risk that they are injured when the supplemental front air bag inflates.

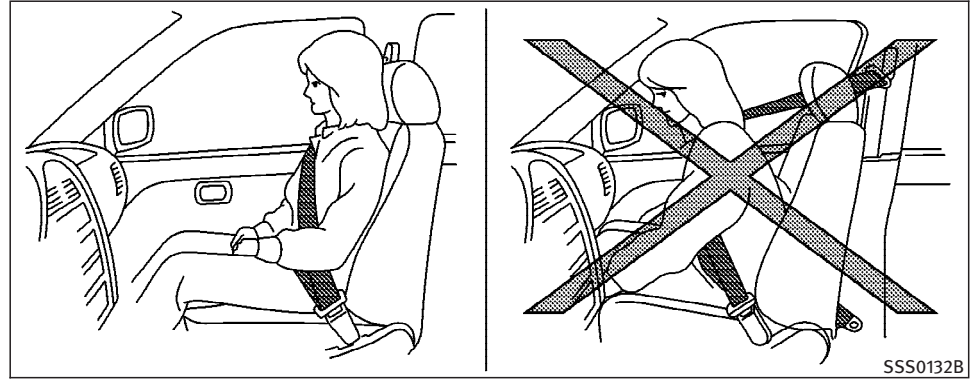

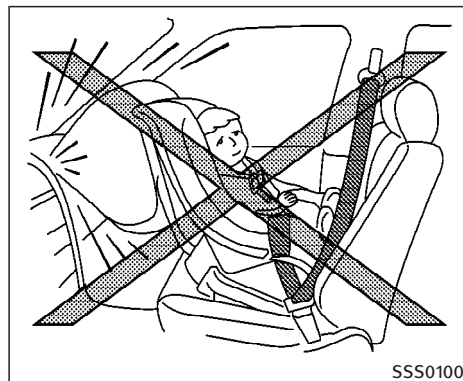
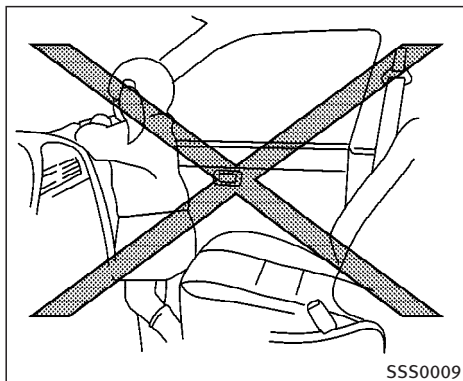
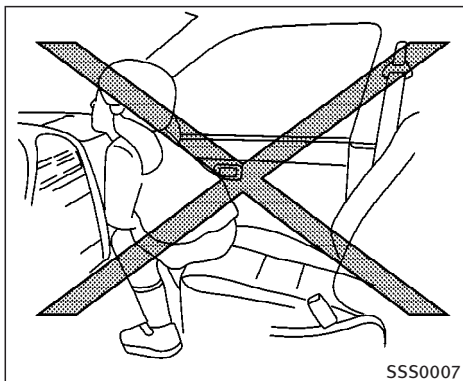
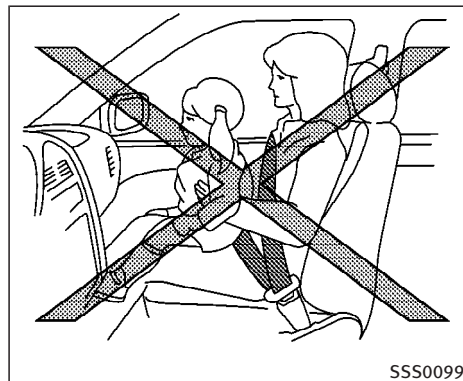
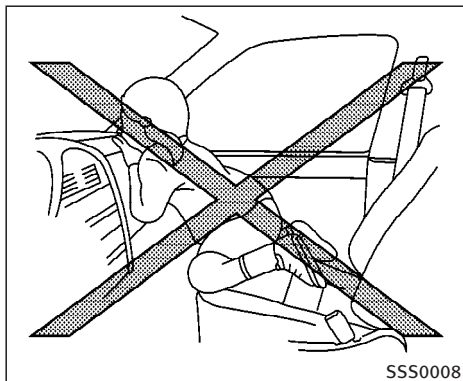
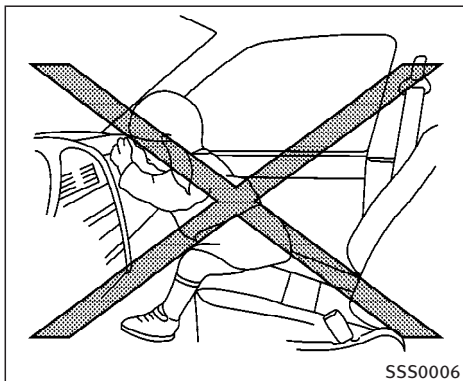



WARNING

- Never let children ride unrestrained or extend their hands or face out of the window. Do not attempt to hold them in your lap or arms. Some examples of dangerous riding positions are shown in the previous illustrations.
- Children may be severely injured or killed when the supplemental front air bags, side air bags or curtain side-impact air bags inflate if they are not properly restrained. Pre-teens and children should be properly restrained in the rear seat, if possible.
- Even with the INFINITI advanced air bag system, never install a rear-facing child restraint in the front seat. An inflating supplemental front air bag could seriously injure or kill your child. For additional information, see “Child restraints” earlier in this section.

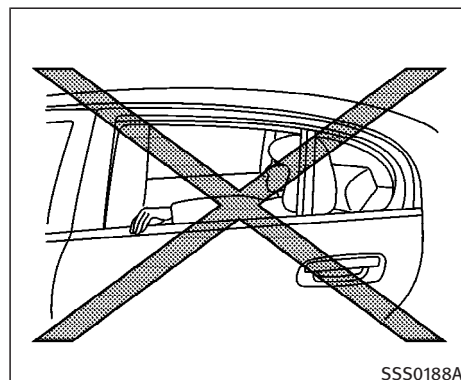
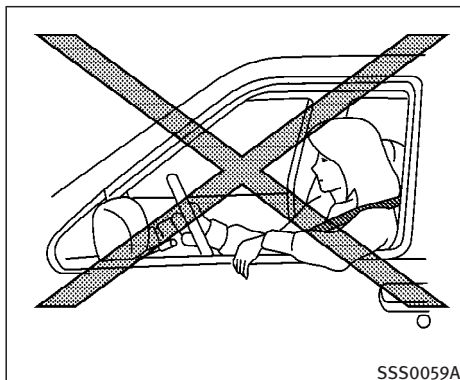

WARNING

Supplemental side air bag and curtain side-impact air bag:

- The supplemental side air bag and curtain side-impact air bag ordinarily will not inflate in the event of a frontal impact, rear impact, rollover or lower severity side collision. Always wear your seat belts to help reduce the risk or severity of injury in various kinds of accidents.

- The seat belts, the supplemental side air bags and curtain side-impact air bags are most effective when you are sitting well back and upright in the seat. The side air bag and curtain side-impact air bag inflate with great force. Do not allow anyone to place their hand, leg or face near the side air bag on the side of the seatback of the front seat or near the side roof rails. Do not allow anyone sitting in the front seats or rear outboard seats to extend their hand out of the

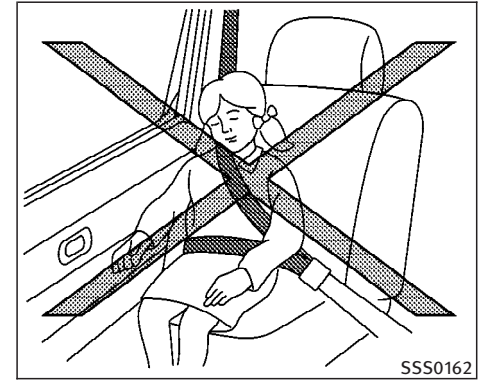
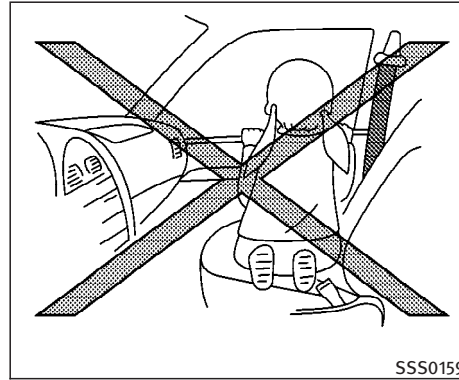
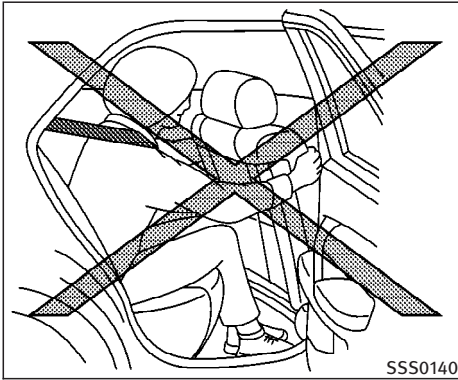

window or lean against the door. Some examples of dangerous riding positions are shown in the previous illustrations.

- When sitting in the rear seat, do not hold onto the seatback of the front seat. If the side air bag inflates, you may be seriously injured. Be especially careful with children, who should always be properly restrained.
- Do not use seat covers on the front seatbacks. They may interfere with supplemental side air bag inflation.

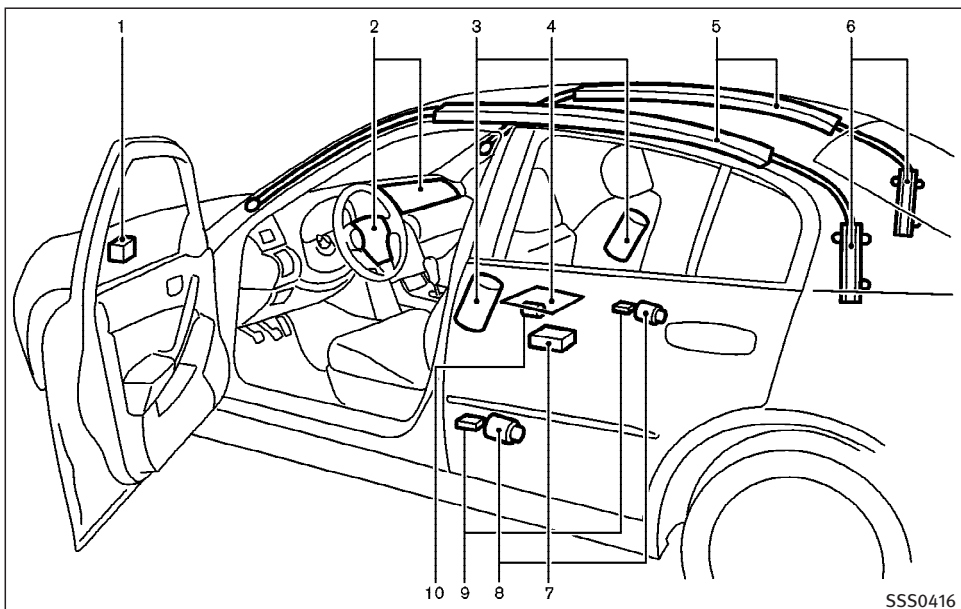

Sedan

SS50416

- | | |
|--|---|
| <ol style="list-style-type: none"> 1. Crash zone sensor 2. Supplemental front air bag modules 3. Supplemental side air bag modules 4. Occupant classification sensor (pressure sensor) | <ol style="list-style-type: none"> 5. Supplemental curtain side-impact air bags 6. Supplemental curtain side-impact air bag modules 7. Diagnosis sensor unit |
|--|---|

8. Seat belt pre-tensioner
9. Satellite sensors
10. Occupant classification system control unit

INFINITI ADVANCED AIR BAG SYSTEM (front seats)

This vehicle is equipped with the INFINITI advanced air bag system for the driver and front passenger seats. This system is designed to meet certification requirements under U.S. regulations. It is also permitted in Canada. **However, all of the information, cautions and warnings in this manual still apply and must be followed.**

The driver supplemental air bag is located in the center of the steering wheel. The front passenger supplemental air bag is mounted in the dashboard above the glove box. The supplemental front air bags are designed to inflate in higher severity frontal collisions, although they may inflate if the forces in another type of collision are similar to those of a higher severity frontal impact. They may not inflate in certain frontal collisions. Vehicle damage (or lack of it) is not always an indication of proper supplemental air bag operation.

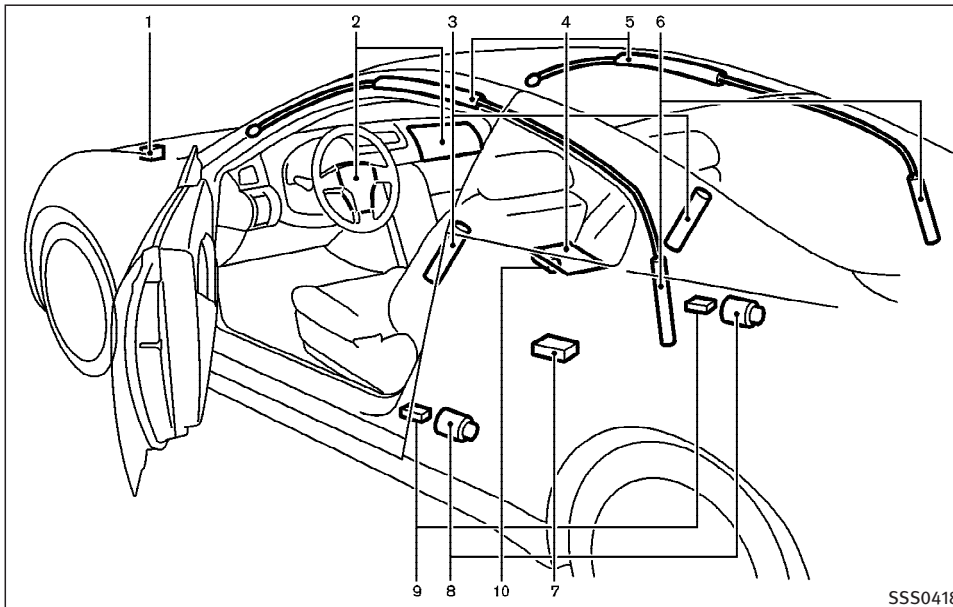

SSS0418

Coupe

The INFINITI advanced air bag system has dual stage inflators. It also monitors information from the crash zone sensor, the diagnosis sensor unit, seat belt buckle switches, occupant classification sensor (pressure sensor) and passenger seat belt

tension sensor. Inflator operation is based on the severity of a collision and seat belt usage for the driver. For the front passenger, it additionally monitors the weight of an occupant or object on the seat and seat belt tension. Based on

information from the sensors, only one front air bag may inflate in a crash, depending on the crash severity and whether the front occupants are belted or unbelted. Additionally, the front passenger air bag may be automatically turned OFF under some conditions, depending on the pressure detected on the passenger seat and how the seat belt is used. If the front passenger air bag is OFF, the passenger air bag status light will be illuminated (if the seat is unoccupied, the light will not be illuminated, but the air bag will be off). See “Front passenger air bag and status light” later in this section for further details. One front air bag inflating does not indicate improper performance of the system.

If you have any questions about your air bag system, contact an INFINITI dealer. If you are considering modification of your vehicle due to a disability, you may also contact an INFINITI dealer. Contact information is contained in the front of this Owner’s Manual.

When a supplemental front air bag inflates, a fairly loud noise may be heard, followed by the release of smoke. This smoke is not harmful and does not indicate a fire. Care should be taken not to in-

hale it, as it may cause irritation and choking. Those with a history of a breathing condition should get fresh air promptly.

Supplemental front air bags, along with the use of seat belts, help to cushion the impact force on the face and chest of the front occupants. They can help save lives and reduce serious injuries. However, an inflating front air bag may cause facial abrasions or other injuries. Front air bags do not provide restraint to the lower body.

Even with INFINITI advanced air bags, seat belts should be correctly worn and the driver and passenger seated upright as far as practical away from the steering wheel or instrument panel. The supplemental front air bags inflate quickly in order to help protect the front occupants. Because of this, the force of the front air bag inflating can increase the risk of injury if the occupant is too close to, or is against, the air bag module during inflation.

The air bag will deflate quickly after a collision.

The supplemental front air bags operate only when the ignition switch is in the ON or START position.

After turning the ignition switch to the ON position, the supplemental air bag warning light illuminates. The supplemental air bag warning light will turn off after about 7 seconds if the system is operational.



Front passenger air bag status light

Front passenger air bag and status light







WARNING

The front passenger air bag is designed to automatically turn OFF under some conditions. Read this section carefully to learn how it operates. Proper use of the seat, seat belt and child restraints is necessary for most effective protection. Failure to follow

all instructions in this manual concerning the use of seats, seat belts and child restraints can increase the risk or severity of injury in an accident.

Status light:

The front passenger air bag status light  is located in the center display. The light operates as follows:

- Unoccupied passenger seat: The  is OFF and the front passenger air bag is OFF and will not inflate in a crash.
- Passenger seat occupied by a small adult, child or child restraint as outlined in this section: The  illuminates to indicate that the front passenger air bag is OFF and will not inflate in a crash.
- Occupied passenger seat and the passenger meets the conditions outlined in this section: The light  is OFF to indicate that the front passenger air bag is operational.

Front passenger air bag:

The front passenger air bag is designed to automatically turn OFF when the vehicle is

operated under some conditions as described below in accordance with U.S. regulations. If the front passenger air bag is OFF, it will not inflate in a crash. The driver air bag and other air bags in your vehicle are not part of this system.

The purpose of the regulation is to help reduce the risk of injury or death from an inflating air bag to certain front passenger seat occupants, such as children, by requiring the air bag to be automatically turned OFF. Certain sensors are used to meet the requirements.

One sensor used is the occupant classification sensor (pressure sensor). It is in the bottom of the front passenger seat cushion and is designed to detect an occupant and objects on the seat by weight. It works together with seat belt sensors described later. For example, if a child is in the front passenger seat, the advanced air bag system is designed to turn the passenger air bag OFF in accordance with the regulations. Also, if a child restraint of the type specified in the regulations is on the seat, its weight and the child's weight can be detected and cause the air bag to turn OFF. Occupant classification sensor operation can vary depending on the front passenger seat belt sensors.

The front passenger seat belt sensors are designed to detect if the seat belt is buckled and the amount of tension on the seat belt, such as when it is in the automatic locking mode (child restraint mode). Based on the weight on the seat detected by the occupant classification sensor and the belt tension detected on the seat belt, the INFINITI advanced air bag system determines whether the front passenger air bag should be automatically turned OFF as required by the regulations.

Front passenger seat adult occupants who are properly seated and using the seat belt as outlined in this manual should not cause the passenger air bag to be automatically turned OFF. For small adults it may be turned OFF, however, if the occupant takes his/her weight off the seat cushion (for example, by not sitting upright, by sitting on an edge of the seat, or by otherwise being out of position), this could cause the sensor to turn the air bag OFF. In addition, if the occupant improperly uses the seat belt in the automatic locking mode (child restraint mode), this could cause the air bag to be turned OFF. Always be sure to be seated and wearing the seat belt properly for the most effective protection by the seat belt and supplemental air bag.

INFINITI recommends that pre-teens and children be properly restrained in a rear seat. INFINITI also recommends that appropriate child restraints and booster seats be properly installed in a rear seat. If this is not possible, the occupant classification sensor and seat belt sensors are designed to operate as described above to turn the front passenger air bag OFF for specified child restraints as required by the regulations. Failing to properly secure child restraints and to use the automatic locking mode (child restraint mode) may allow the restraint to tip or move in an accident or sudden stop. This can also result in the passenger air bag inflating in a crash instead of being OFF. See “Child restraints” earlier in this section for proper use and installation.

If the front passenger seat is not occupied, the passenger air bag is designed not to inflate in a crash. However, heavy objects placed on the seat could result in air bag inflation, because of the object’s weight detected by the occupant classification sensor. Other conditions could also result in air bag inflation, such as if a child is standing on the seat, or if two children are on the seat, contrary to the instructions in this manual. Always be

sure that you and all vehicle occupants are seated and restrained properly.

Using the passenger air bag status light, you can monitor when the front passenger air bag is automatically turned OFF with the seat occupied. The light will not illuminate when the front passenger seat is unoccupied.

If an adult occupant is in the seat but the passenger air bag status light is illuminated (indicating that the air bag is OFF), it could be that the person is a small adult, or is not sitting on the seat properly or is not using the seat belt properly.

If a child restraint must be used in the front seat, the passenger air bag status light may or may not be illuminated, depending on the size of the child and the type of child restraint being used. If the passenger air bag status light is not illuminated (indicating that the air bag might inflate in a crash), it could be that the child restraint or seat belt is not being used properly. In rare cases, the passenger air bag status light will not illuminate even though the air bag is OFF.

If such situations happen, properly position and restrain the occupant or child restraint. Otherwise reposition the occupant

or child restraint in a rear seat. If you have any questions about whether your passenger air bag is working as designed, your INFINITI dealer can confirm that it is working properly by using a special tool.

The INFINITI advanced air bag system and passenger air bag status light will take a few seconds to register a change in the passenger seat status. For example, if a large adult who is sitting in the front passenger seat exits the vehicle, the passenger air bag status light will change from OFF to ON for a few seconds and then to OFF. This is normal system operation and does not indicate a malfunction.

If a malfunction occurs in the front passenger air bag system, the supplemental air bag warning light  , located in the meter and gauges area will blink. Have the system checked by an INFINITI dealer.

Other supplemental front air bag precautions



WARNING

- Do not place any objects on the steering wheel pad or on the instrument panel. Also, do not place any objects between any occupant and the steering wheel or instrument panel. Such objects may become dangerous projectiles and cause injury if the supplemental front air bag inflates.
- Immediately after inflation, several front air bag system components will be hot. Do not touch them; you may severely burn yourself.
- No unauthorized changes should be made to any components or wiring of the supplemental air bag system. This is to prevent accidental inflation of the supplemental air bag or damage to the supplemental air bag system.
- Do not make unauthorized changes to your vehicle's electrical system, suspension system or front end structure.

This could affect proper operation of the supplemental front air bag system.

- Tampering with the supplemental front air bag system may result in serious personal injury. Tampering includes changes to the steering wheel and the instrument panel assembly by placing material over the steering wheel pad and above the instrument panel or by installing additional trim material around the air bag system.
- Modifying or tampering with the front passenger seat may result in serious personal injury. For example, do not change the front seats by placing material on the seat cushion or by installing additional trim material, such as seat covers, on the seat. Additionally, do not stow any objects under the front passenger seat or the seat cushion and seat-back. Such objects may interfere with the proper operation of the occupant classification sensor (pressure sensor).

- No unauthorized changes should be made to any components or wiring of the seat belt system. This may affect the supplemental front air bag system. Tampering with the seat belt system may result in serious personal injury.
- Work around and on the supplemental front air bag system should be done by an INFINITI dealer. Installation of electrical equipment should also be done by an INFINITI dealer. The yellow and orange Supplemental Restraint System (SRS) wiring and connectors should not be modified or disconnected. Unauthorized electrical test equipment and probing devices should not be used on the air bag system.
- A cracked windshield should be replaced immediately by a qualified repair facility. A cracked windshield could affect the function of the supplemental air bag system.
- The SRS wiring harness connectors are yellow and orange for easy identification.

When selling your vehicle, we request that you inform the buyer about the supplemental front air bag system and guide the buyer to the appropriate sections in this Owner's Manual.

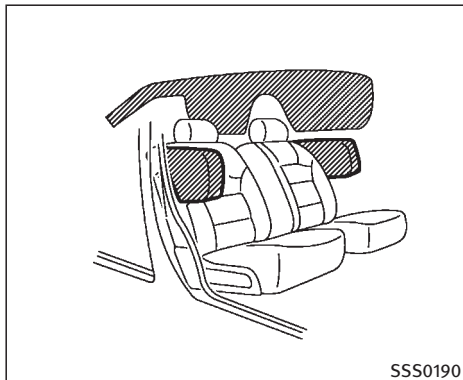

SUPPLEMENTAL SIDE AIR BAG AND CURTAIN SIDE-IMPACT AIR BAG SYSTEMS

The supplemental side air bags are located in the outside of the seatback of the front seats. The supplemental curtain side-impact air bags are located in the side roof rails. These systems are designed to meet voluntary guidelines to help reduce the risk of injury to out-of-position occupants. **However, all of the information, cautions and warnings in this manual still apply and must be followed.** The supplemental side air bags and cur-

tain side-impact air bags are designed to inflate in higher severity side collisions on the side of the vehicle impacted, although they may inflate if the forces in another type of collision are similar to those of a higher severity side impact. They are designed to inflate on the side where the vehicle is impacted. They may not inflate in certain side collisions.

Vehicle damage (or lack of it) is not always an indication of proper supplemental side air bag and curtain side-impact air bag operation.

When the supplemental side air bag and curtain side-impact air bag inflate, a fairly loud noise may be heard, followed by release of smoke. This smoke is not harmful and does not indicate a fire. Care should be taken not to inhale it, as it may cause irritation and choking. Those with a history of a breathing condition should get fresh air promptly.

Supplemental side air bags, along with the use of seat belts, help to cushion the impact force on the chest of the front occupants. Curtain side-impact air bags help to cushion the impact force to the head of occupants in the front and rear outboard seating positions. They can help save lives and reduce serious injuries. However, an inflating side air bag, or curtain side-

impact air bag may cause abrasions or other injuries. Supplemental side air bags and curtain side-impact air bags do not provide restraint to the lower body.

The seat belts should be correctly worn and the driver and passenger seated upright as far as practical away from the supplemental side air bag. Rear seat passengers should be seated as far away as practical from the door finishers and side roof rails. The side air bags and curtain side-impact air bag inflate quickly in order to help protect the front occupants. Because of this, the force of the side air bag and curtain side-impact air bag inflating can increase the risk of injury if the occupant is too close to, or is against, these air bag modules during inflation. The side air bag and curtain side-impact air bag will deflate quickly after the collision is over.

The supplemental side air bags and curtain side-impact air bags operate only when the ignition switch is in the ON or START position.

After turning the ignition switch to the ON position, the supplemental air bag warning light illuminates. The air bag warning light will turn off after about 7 seconds if the systems are operational.



WARNING

- Do not place any objects near the seat-back of the front seats. Also, do not place any objects (an umbrella, bag, etc.) between the front door finisher and the front seat. Such objects may become dangerous projectiles and cause injury if the side air bag inflates.
- Right after inflation, several side air bag and curtain side-impact air bag system components will be hot. Do not touch them; you may severely burn yourself.
- No unauthorized changes should be made to any components or wiring of the side air bag and curtain side-impact air bag system. This is to prevent accidental inflation of the side air bag and curtain side-impact air bag or damage to the side air bag and curtain side-impact air bag system.
- Do not make unauthorized changes to your vehicle's electrical system, suspension system or side panel. This

could affect proper operation of the supplemental side air bag and curtain side-impact air bag system.

- Tampering with the supplemental system may result in serious personal injury. For example, do not change the front seats by placing material near the seatback or by installing additional trim material, such as seat covers, around the side air bag.
- Work around and on the side air bag and curtain side-impact air bag system should be done by an INFINITI dealer. Installation of electrical equipment should also be done by an INFINITI dealer. The SRS wiring harnesses* should not be modified or disconnected. Unauthorized electrical test equipment and probing devices should not be used on the side air bag system.

* The SRS wiring harness connectors are yellow and orange for easy identification.

When selling your vehicle, we request that you inform the buyer about the side air bag and curtain side-impact air bag system and guide the buyer to the appropriate sections in this Owner's Manual.

Pre-tensioner seat belt system (front seats)



WARNING

- The pre-tensioner seat belt cannot be reused after activation. It must be replaced together with the retractor and buckle as a unit.
- If the vehicle becomes involved in a frontal collision but the pre-tensioner is not activated, be sure to have the pre-tensioner system checked and, if necessary, replaced by an INFINITI dealer.
- No unauthorized changes should be made to any components or wiring of the pre-tensioner seat belt system. This is to prevent accidental activation of the pre-tensioner seat belt or damage to the pre-tensioner seat belt operation. Tampering with the pre-tensioner seat

belt system may result in serious personal injury.

- **Work around and on the pre-tensioner system should be done by an INFINITI dealer. Installation of electrical equipment should also be done by an INFINITI dealer. Unauthorized electrical test equipment and probing devices should not be used on the pre-tensioner seat belt system.**
- **If you need to dispose of the pre-tensioner or scrap the vehicle, contact an INFINITI dealer. Correct pre-tensioner disposal procedures are set forth in the appropriate INFINITI Service Manual. Incorrect disposal procedures could cause personal injury.**

The front seat pre-tensioner seat belt system activates in conjunction with the front supplemental air bag systems. Working with the seat belt retractor, it helps tighten the seat belt when the vehicle becomes involved in certain types of collisions, helping to restrain front seat occupants.

The pre-tensioner is encased with the seat belt's retractor. These seat belts are used the same as conventional seat belts.

When the pre-tensioner seat belt activates, smoke is released and a loud noise may be heard. This smoke is not harmful and does not indicate a fire. Care should be taken not to inhale it, as it may cause irritation and choking. Those with a history of a breathing condition should get fresh air promptly.

If any abnormality occurs in the pre-tensioner seat belt system, the supplemental air bag warning light  will not come on, will flash intermittently or will turn on for 7 seconds and remain on after the ignition switch has been turned to the ON or START position. In this case, the pre-tensioner seat belt may not function properly. They must be checked and repaired. Take your vehicle to an INFINITI dealer.

When selling your vehicle, we request that you inform the buyer about the pre-tensioner seat belt system and guide the buyer to the appropriate sections in this Owner's Manual.

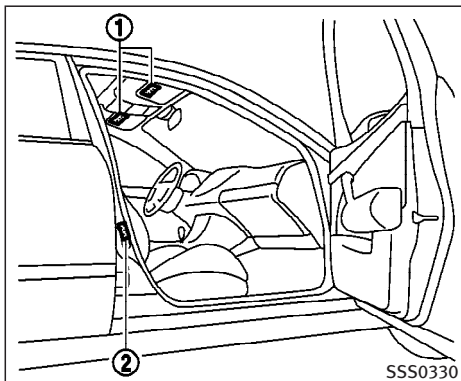

- ① SRS air bag warning labels
The warning labels are located on the surface of the sun visors.
- ② SRS side-impact air bag warning label
The warning label is located on the side of the passenger's side center pillar.

SUPPLEMENTAL AIR BAG WARNING LABELS

Warning labels about the supplemental front air bag and supplemental side air bag systems are placed in the vehicle as shown in the illustration.



SUPPLEMENTAL AIR BAG WARNING LIGHT

The supplemental air bag warning light, displaying  in the instrument panel, monitors the circuits of the supplemental front air bag, supplemental side air bag and curtain side-impact air bag and pretensioner seat belt systems. The circuits monitored by the air bag warning light are the diagnosis sensor unit, satellite sensors, crash zone sensor, front air bag modules, side air bag modules, curtain side-impact air bag modules, pretensioner seat belts and all related wiring.

When the ignition key is in the ON or START position, the supplemental air bag warning light illuminates for about 7 seconds and then turns off. This means the system is operational.

If any of the following conditions occur, the supplemental front air bag, supplemental side air bag and curtain side-impact air bag, and pretensioner seat belt systems need servicing:

- The supplemental air bag warning light remains on after approximately 7 seconds.
- The supplemental air bag warning light flashes intermittently.
- The supplemental air bag warning light does not come on at all.

Under these conditions, the supplemental front air bags, supplemental side air bags, curtain side-impact air bag or pretensioner seat belt systems may not operate properly. They must be checked and repaired. Take your vehicle to the nearest INFINITI dealer.



WARNING

If the supplemental air bag warning light is on, it could mean that the supplemental front air bag, supplemental side air bag, curtain side-impact air bag systems and/or pre-tensioner seat belt systems will not operate in an accident. To help avoid injury to yourself or others, have your vehicle checked by an INFINITI dealer as soon as possible.

Repair and replacement procedure

The supplemental front air bags, supplemental side air bags, curtain side-impact air bags and pre-tensioner seat belts are designed to activate on a one-time-only basis. As a reminder, unless it is damaged, the supplemental air bag warning light remains illuminated after inflation has occurred. Repair and replacement of these systems should be done only by an INFINITI dealer.

When maintenance work is required on the vehicle, the supplemental front air bags, side air bags, curtain side-impact air bags, pre-tensioner seat belts and related parts should be pointed out to the

person performing the maintenance. The ignition switch should always be in the LOCK position when working under the hood or inside the vehicle.



WARNING

- Once a supplemental front air bag, supplemental side air bag or curtain side-impact air bag has inflated, the air bag module will not function again and must be replaced. Additionally, if any of the supplemental front air bags inflate, the activated pre-tensioner seat belts must also be replaced. The air bag module and pre-tensioner seat belt system should be replaced by an INFINITI dealer. The air bag module and pre-tensioner seat belt system cannot be repaired.
- The supplemental front air bag, side air bag and curtain side-impact air bag systems, and the pre-tensioner seat belt system should be inspected by an INFINITI dealer if there is any damage to the front end or side portion of the vehicle.

- If you need to dispose of these supplemental systems or scrap the vehicle, contact an INFINITI dealer.

Correct disposal procedures are set forth in the appropriate INFINITI Service Manual. Incorrect disposal procedures could cause personal injury.

MEMO

2 Instruments and controls

Instrument panel	2-2	Hazard warning flasher switch	2-25
Meters and gauges	2-3	Horn	2-26
Speedometer and odometer	2-3	Heated seats	2-26
Tachometer	2-4	SNOW mode switch (if so equipped)	2-27
Engine coolant temperature gauge	2-4	Vehicle Dynamic Control (VDC) off switch	2-28
Fuel gauge	2-5	Clock	2-29
Compass display	2-6	Adjusting the time	2-29
Warning/indicator lights and audible		Power outlet	2-29
reminders	2-9	Cigarette lighter and ashtray	2-30
Checking bulbs	2-9	Front	2-30
Warning lights	2-9	Rear	2-30
Indicator lights	2-14	Storage	2-31
Audible reminders	2-16	Door pocket	2-31
Security systems	2-17	Instrument pocket (except for navigation	
Vehicle security system	2-17	system equipped models)	2-31
INFINITI Vehicle Immobilizer System	2-18	Sunglasses holder	2-32
Windshield wiper and washer switch	2-19	Cup holder	2-32
Rear window and outside mirror defroster		Glove box	2-35
switch	2-20	Upper glove box (except for navigation	
Headlight and turn signal switch	2-21	system equipped models)	2-35
Xenon headlights	2-21	Console box	2-36
Headlight switch	2-21	Rear armrest pocket (Sedan)	2-37
Turn signal switch	2-24	Card holder (driver's side)	2-38
Fog light switch	2-25	Coat hook (Coupe)	2-38

Stowing golf bags (Coupe)	2-39
Windows.....	2-39
Power windows	2-39
Automatic adjusting function (Coupe)	2-41
Sunroof (if so equipped).....	2-42
Automatic sunroof.....	2-42
Interior lights	2-44
Room light	2-44
Map lights.....	2-44
Personal lights	2-45
Vanity mirror light (if so equipped).....	2-46
Trunk light.....	2-46

HomeLink [®] Universal Transceiver (if so equipped).....	2-46
Programming HomeLink [®]	2-47
Programming HomeLink [®] for Canadian customers	2-48
Operating the HomeLink [®] Universal Transceiver.....	2-49
Programming trouble-diagnosis.....	2-49
Clearing the programmed information.....	2-49
Reprogramming a single HomeLink [®] button	2-49
If your vehicle is stolen	2-50

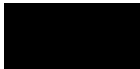

INSTRUMENT PANEL

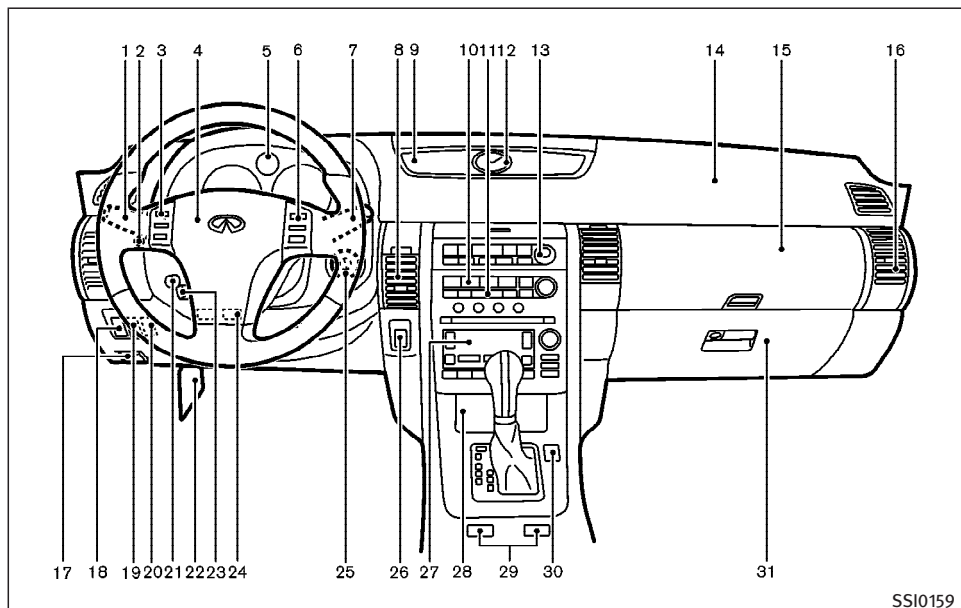

1. Headlight, fog light and turn signal switch
2. Security indicator light
3. Steering wheel switch for audio control or steering wheel switch for

- Bluetooth® Hands-Free Phone System (if so equipped)
4. Driver supplemental air bag/Horn
5. Meters/gauges
6. Cruise control main/set switch
7. Windshield wiper/washer switch

8. Center ventilator
9. Center display - Compass, Air conditioner, Ambient temperature, Front passenger air bag status light
10. Rear window and outside mirror defogger switch
11. Heater/air conditioner control
12. Clock
13. Navigation system* (if so equipped)
14. Passenger supplemental air bag
15. Upper glove box (except for Navigation system equipped models)
16. Side ventilator
17. Hood lock release handle
18. Trunk lid release switch
19. Vehicle Dynamic Control (VDC) off switch
20. Instrument brightness control
21. Outside mirror remote control switch
22. Fuse box
23. Electric steering column control (if so equipped)
24. Manual steering column control
25. Ignition switch/steering lock
26. Snow mode switch (if so equipped)
27. Audio system
28. Ashtray/Cigarette lighter
29. Heated seat switch
30. Hazard warning flasher switch
31. Glove box

*: Refer to the separate Navigation System Owner's Manual.

METERS AND GAUGES

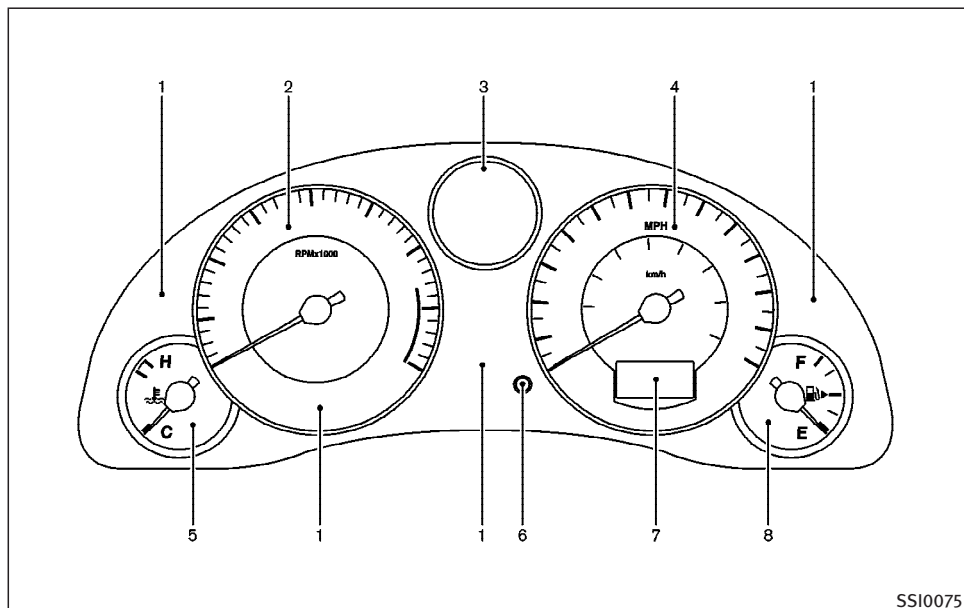

1. Warning/Indicator lights
2. Tachometer
3. Automatic transmission position indicator (AT models)/Manual transmission up-shift indicator (MT models)
4. Speedometer
5. Engine coolant temperature gauge
6. Trip odometer reset switch
7. Odometer (Total/Twin trip)/Up-shift indicator setting (MT models)
8. Fuel gauge

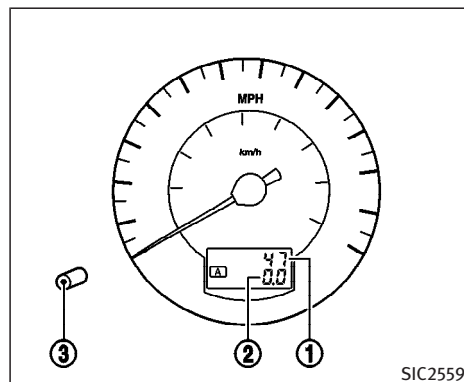

SPEEDOMETER AND ODOMETER

Speedometer

The speedometer indicates vehicle speed.

Odometer/Twin trip odometer/ Up-shift indicator setting (MT models)

The odometer ①/twin trip odometer or up-shift indicator setting (MT models) ② are displayed when the ignition switch is in the ON position.

The odometer records the total distance the vehicle has been driven.

The twin trip odometer records the distance of individual trips.

Changing the display:

Pushing the trip odometer reset switch ③ changes the display as follows.

AT models:

TRIP A → TRIP B → TRIP A

MT models:

TRIP A → TRIP B → Up-shift indicator setting mode → TRIP A

See “Driving the vehicle” in the “5. Starting and driving” section for the use of the up-shift indicator.

Resetting the trip odometer:

Pushing the trip odometer reset switch for more than 1 second resets the trip odometer to zero.

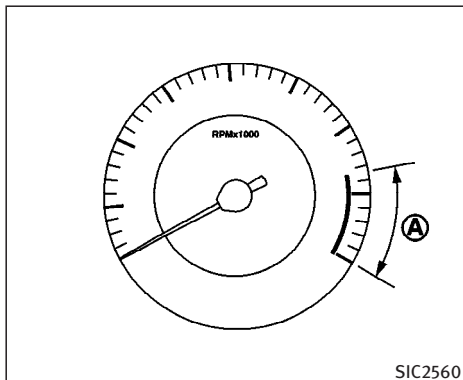

TACHOMETER

The tachometer indicates engine speed in revolutions per minute (rpm). **Do not rev the engine into the red zone ①.**



CAUTION

When engine speed approaches the red zone, shift to a higher gear. Operating the engine in the red zone may cause serious engine damage.

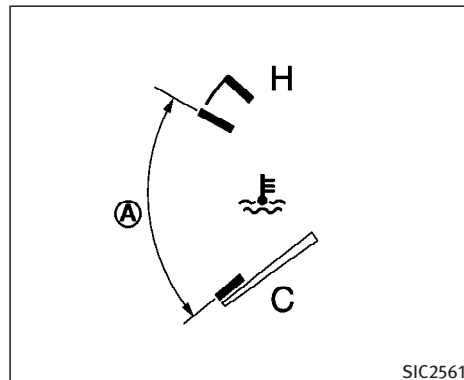

ENGINE COOLANT TEMPERATURE GAUGE

The gauge indicates the engine coolant temperature.

The engine coolant temperature is within the normal range ① when the gauge needle points within the zone shown in the illustration.

The engine coolant temperature will vary with the outside air temperature and driving conditions.



CAUTION

If the gauge indicates engine coolant temperature near the hot (H) of the normal range, reduce vehicle speed to decrease temperature. If gauge is over the normal range, stop the vehicle as soon as safely possible. If the engine is overheated, continued operation of the vehicle may seriously damage the engine. See “If your vehicle overheats” in the “6. In case of emergency” section for immediate action required.

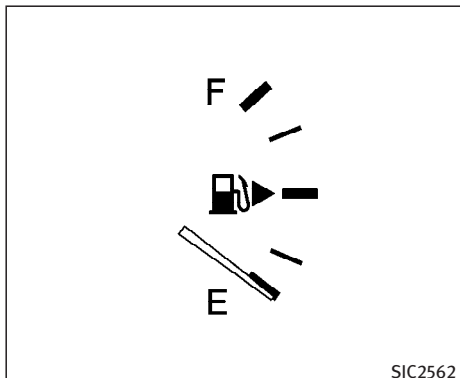

FUEL GAUGE

The gauge indicates the approximate fuel level in the tank.

The gauge may move slightly during braking, turning, acceleration, or going up or down hill.

The gauge needle is designed to move to the E (Empty) position when the ignition key is turned to the OFF position.

Refill the fuel tank before the gauge registers the E (Empty) position.

The low fuel warning light comes on when the fuel tank is getting low. Refuel as soon as it is convenient, preferably before the gauge reaches the E (Empty) position. There will be a small reserve of fuel in the tank when the fuel gauge needle reaches the E (Empty) position.

The  indicates that the fuel-filler door is located on the passenger's side of the vehicle.



CAUTION

- If the vehicle runs out of fuel, the malfunction indicator lamp (MIL) may come on. Refuel as soon as possible. After a few driving trips, the  lamp should turn off. If the lamp remains on after a few driving trips, have the vehicle inspected by an INFINITI dealer.
- For additional information, see “Malfunction indicator lamp (MIL)” later in this section.

COMPASS DISPLAY

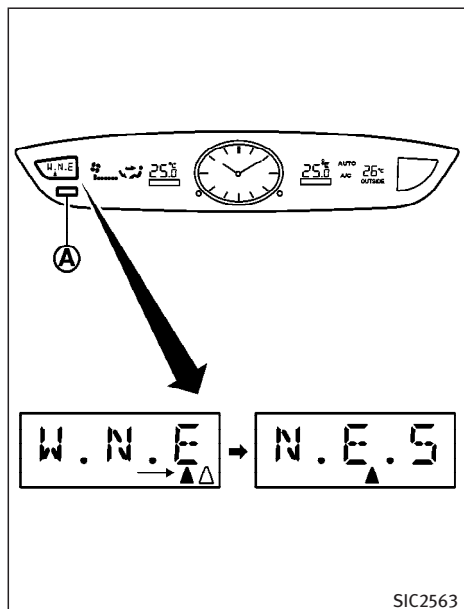

N: north

E: east

S: south

W: west

▲: vehicle direction

The above example shows the display changes from “East” to “East-southeast”.

If the compass unit does not receive any correct signal for 10 minutes, the compass will display the bar “-- -- --”. Have the vehicle checked by an INFINITI dealer.

The compass is located in the center display.

Push COMP switch (A) to turn the display on or off when the ignition switch is in the ON position. The heading direction will be displayed.

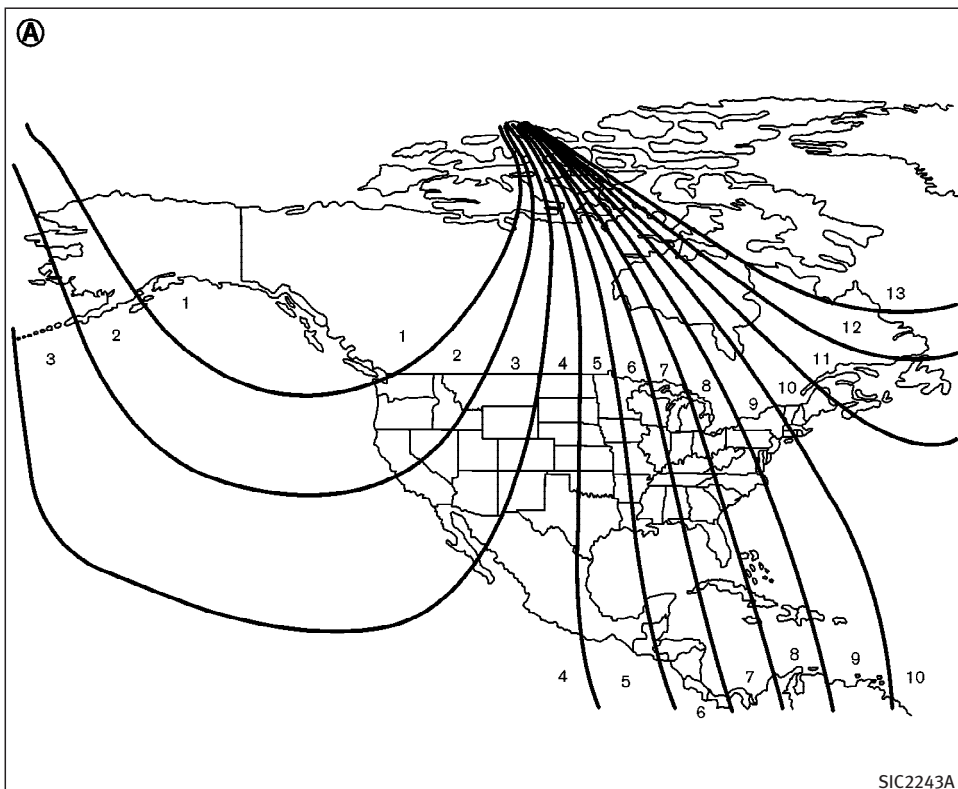

Zone variation change procedure

The difference between magnetic north and geographical north is known as variance. In some areas, this difference can sometimes be great enough to cause false compass readings. Follow these instructions to set the variance for your particular location if this happens:

1. Establish your location on the zone map **(A)**. Record your zone number.
2. Turn the ignition switch to the ON position while pushing the COMP switch.
3. Continue to push the COMP switch for more than 5 seconds until the current zone entry number is displayed on the compass display.

If any operations are not carried out for more than 5 seconds, the display shows direction as normal.

4. Push the COMP switch repeatedly until the new zone entry number is displayed.

Once the desired zone number is displayed, stop pushing the COMP switch and the display will show compass direction within a few seconds.

If a magnet is located near the driver side instrument panel (the sensor is located inside) or the vehicle is driven where the terrestrial magnetism is disturbed, the compass display may not indicate the correct direction.

- The compass may not display correctly at the following places:
 - under a bridge
 - among buildings
 - on an iron bridge
 - inside a tunnel
 - above a subway
 - on a railway crossing
 - in an underground parking lot
 - near a huge vehicle
 - near a transformer substation

If you carry out correction procedure at one of the above places, the procedure may not be completed correctly.



























- If air conditioner fan speed is maximum, the compass display may shake. This is normal. Reduce the fan speed to avoid shaking the display.

Correction functions of the compass display

If the direction is not shown correctly, carry out the correction procedure below.





1. Push the COMP switch for about 10 seconds. The direction bar starts blinking.
2. Turn off electrical equipment such as lights, hazard indicator, air conditioner, etc. Then drive the vehicle slowly (less than 3 MPH (5 km/h)) and turn the vehicle one or more times in an open and safe area. When the compass displays the direction, the procedure is completed.

WARNING/INDICATOR LIGHTS AND AUDIBLE REMINDERS

 AWD	All-wheel drive (AWD) warning light (AWD models)		Low tire pressure warning light	 SET	Cruise set switch indicator light
 ABS	or  Anti-lock brake warning light		Low washer fluid warning light		Front passenger air bag status light
 AT CHECK	Automatic transmission check warning light		P position selecting warning light (for Intelligent Key system)		High beam indicator light (Blue)
 BRAKE	or  Brake warning light	 RAS	Rear Active Steer (RAS) warning light (if so equipped)		Malfunction indicator lamp (MIL)
	Charge warning light		Seat belt warning light	 SLIP	Slip indicator light
	Door open warning light		Supplemental air bag warning light	 SNOW	Snow mode indicator light (if so equipped)
	Engine oil pressure warning light		Automatic transmission position indicator light		Turn signal/hazard indicator lights
 KEY	Intelligent Key warning light (for Intelligent Key system)	 CRUISE	Cruise main switch indicator light		Vehicle Dynamic Control (VDC) off indicator light
	Low fuel warning light				

CHECKING BULBS

Apply the parking brake and turn the ignition key to ON without starting the engine. The following lights will come on:

 , BRAKE OR  ,  ,  , **AWD**

The following lights come on briefly and then go off:

 , **ABS** OR  , **SLIP** , **AT CHECK** , **VDC OFF** ,

 ,  ,  , **RAS**

If any light fails to come on, it may indicate a burned-out bulb or an open circuit in the electrical system. Have the system repaired promptly.

WARNING LIGHTS

 **AWD** All-wheel drive (AWD) warning light (AWD models)

The light comes on when the ignition switch is turned to ON. It turns off soon after the engine is started.

If the AWD system malfunctions, or the diameter of the front and the rear wheels are different, the warning light will either remain illuminated or blink. See “All-wheel drive (AWD) warning light” in the “5. Starting and driving” section.



CAUTION

- If the warning light comes on while driving there may be a malfunction in the AWD system. Reduce the vehicle speed and have your vehicle checked by an INFINITI dealer as soon as possible.
- Do not drive on dry, hard surface roads in the SNOW mode.
- If the AWD warning light blinks on when you are driving:
 - blinks rapidly (about twice a second): Pull off the road in a safe area, and idle the engine. The driving mode will change to 2WD to prevent the AWD system from malfunctioning. If the warning light turns off, you can drive again.

- blinks slowly (about once every 2 seconds):

Pull off the road in a safe area, and idle the engine. Check that all tire sizes are the same, tire pressure is correct and tires are not worn.

If the warning light is still on after the above operations, have your vehicle checked by an INFINITI dealer as soon as possible.



or



Anti-lock brake warning light

When the ignition switch is turned to the ON position, the anti-lock brake warning light will illuminate and then turn off. This indicates the anti-lock brake system (ABS) is operational.

If the light comes on while the engine is running, it may indicate the anti-lock brake system is not functioning properly. Have the system checked by an INFINITI dealer.

If a malfunction occurs in the system, the anti-lock function of the brake will cease operation but the ordinary brakes will continue to operate. See “Anti-lock brake

system (ABS)” in the “5. Starting and driving” section for further details.

If the light comes on while you are driving, contact an INFINITI dealer for repair.



Automatic transmission check warning light

When the ignition switch is turned to the ON position, the automatic transmission check warning light comes on and then turns off. This indicates that the automatic transmission system is operational.

If the light comes on while the engine is running or while driving, it may indicate that the automatic transmission system is not functioning properly. Have an INFINITI dealer check and repair the transmission.



Brake warning light

The brake warning light indicates the parking brake system operation, low brake fluid level of the brake system and Anti-lock Brake System (ABS) malfunction.

Parking brake indicator:

When the ignition switch is in the ON position, the light comes on when the parking brake is applied.

Low brake fluid warning light:

The light warns of a low brake fluid level. If the light comes on while the engine is running with the parking brake not applied, stop the vehicle and perform the following:

1. Check the brake fluid level. Add brake fluid as necessary. See “Brake fluid” in the “8. Maintenance and do-it-yourself” section.
2. If the brake fluid level is correct, have the warning system checked by an INFINITI dealer.

Anti-lock Brake System (ABS) warning indicator:

When the parking brake is released and the brake fluid level is sufficient, if both the brake warning light and the anti-lock brake system warning light illuminate, it may indicate the anti-lock brake system is not functioning properly. Have the brake system checked by an INFINITI dealer. See “Anti-lock brake warning light” earlier in this section.



WARNING

- Your brake system may not be working properly if the warning light is on. Driving could be dangerous. If you judge it to be safe, drive carefully to the nearest service station for repairs. Otherwise, have your vehicle towed because driving it could be dangerous.
- Pressing the brake pedal with the engine stopped and/or a low brake fluid level may increase your stopping distance and braking will require greater pedal effort as well as pedal travel.
- If the brake fluid level is below the **MINIMUM** or **MIN** mark on the brake fluid reservoir, do not drive until the brake system has been checked by an INFINITI dealer.



Charge warning light

If the light comes on while the engine is running, it may indicate that the charging system is not functioning properly. Turn the engine off and check the alternator

belt. If the belt is loose, broken, missing or if the light remains on, see an INFINITI dealer immediately.



CAUTION

Do not continue driving if the generator belt is loose, broken or missing.



Door open warning light

This light comes on when any of the doors are not closed securely while the ignition switch is in the ON position.



Engine oil pressure warning light

This light warns of low engine oil pressure. If the light flickers or comes on during normal driving, pull off the road in a safe area, stop the engine **immediately** and call an INFINITI dealer or other authorized repair shop.

The engine oil pressure warning light is not designed to indicate a low oil level. Use the dipstick to check the oil level. See “Engine oil” in the “8. Maintenance and do-it-yourself” section.



CAUTION

Running the engine with the engine oil pressure warning light on could cause serious damage to the engine almost immediately. Turn off the engine as soon as it is safe to do so.



Intelligent Key warning light (for Intelligent Key system)

This light comes on in green when it is possible to turn the ignition switch.

When the light comes on in red, it is not possible to turn the switch.

- The warning light blinks in red when the Intelligent Key is outside the vehicle with the ignition switch in the ACC or ON position. Confirm the location of the key as soon as possible when the warning light blinks in red. Be sure to carry the Intelligent Key with you while driving the vehicle.
- The warning light goes off about 10 seconds after the Intelligent Key is brought inside the vehicle.



Low fuel warning light

This light comes on when the fuel in the tank is getting low. Refuel as soon as it is convenient, preferably before the fuel gauge reaches the E (Empty) position.

There will be a small reserve of fuel remaining in the fuel tank when the fuel gauge needle reaches the E (Empty) position.



Low tire pressure warning light

Your vehicle is equipped with a tire pressure monitoring system (TPMS) that monitors the tire pressure of all tires except the spare.

The low tire pressure warning light warns of low tire pressure or indicates that the TPMS is not functioning properly.

After the ignition switch is turned ON, this light illuminates for about 1 second and turns off.

Low tire pressure warning:

If the vehicle is being driven with low tire pressure, the warning light will illuminate.

When the low tire pressure warning light illuminates, you should stop and adjust

the tire pressure to the recommended COLD tire pressure shown on the Tire and Loading Information label to turn the light OFF.

For additional information, see “Tire pressure monitoring system (TPMS)” in the “5. Starting and driving” section and in the “6. In case of emergency” section.

TPMS malfunction:

If the TPMS is not functioning properly, the low tire pressure warning light will flash for approximately 1 minute when the ignition switch is turned ON. The light will remain on after the 1 minute. Have the system checked by an INFINITI dealer.

For additional information, see “Tire pressure monitoring system (TPMS)” in the “5. Starting and driving” section.



WARNING

- If the light does not illuminate with the ignition switch turned ON, have the vehicle checked by an INFINITI dealer as soon as possible.

- If the light illuminates while driving, avoid sudden steering maneuvers or abrupt braking, reduce vehicle speed, pull off the road to a safe location and stop the vehicle as soon as possible. Serious vehicle damage could occur and may lead to an accident and could result in serious personal injury. Check the tire pressure for all four tires. Adjust the tire pressure to the recommended COLD tire pressure shown on the Tire and Loading Information label to turn the low tire pressure warning light OFF. If the light still comes on while driving after adjusting the tire pressure, a tire may be flat. If you have a flat tire, replace it with a spare tire as soon as possible.
- When a spare tire is mounted or a wheel is replaced, tire pressure will not be indicated, the TPMS will not function and the low tire pressure warning light will flash. Contact your INFINITI dealer as soon as possible for tire replacement and/or system resetting.
- Replacing tires with those not originally specified by INFINITI could affect the proper operation of the TPMS.



CAUTION

- The TPMS is not a substitute for the regular tire pressure check. Be sure to check the tire pressure regularly.
- If the vehicle is being driven at speeds of less than 16 MPH (25 km/h), the TPMS may not operate correctly.
- Be sure to install the specified size of tires to the four wheels correctly.



Low washer fluid warning light

This light comes on when the washer tank fluid is at a low level. Add washer fluid as necessary. See “Window washer fluid” in the “8. Maintenance and do-it-yourself” section.



P position selecting warning light (for Intelligent Key system)

The light blinks in red when the selector lever is not in the P (Park) position and you are outside the vehicle with the Intelligent Key.

When the warning light blinks, move the selector lever to P position and return the ignition switch to the LOCK position.

RAS

Rear Active Steer (RAS) warning light (if so equipped)

If the light comes on while the engine is running, it may indicate that there is a malfunction with the Rear Active Steer (RAS) portion of the steering system. Have the system checked by an INFINITI dealer.

For further information about the RAS system, see “Rear Active Steer (RAS) system” in the “5. Starting and driving” section.

If a malfunction occurs in the system, the RAS function will cease but driving can be continued.

If the light comes on while you are driving, contact an INFINITI dealer for repair.



Seat belt warning light and chime

The light and chime remind you to fasten the driver’s seat belt. The light illuminates whenever the ignition switch is pushed to the ON position, and will remain illuminated until the driver’s seat belt is fastened.

tened. At the same time, the chime will sound for about 6 seconds unless the driver's seat belt is securely fastened.

The seat belt warning light may also illuminate if the front passenger's seat belt is not fastened when the front passenger's seat is occupied (if so equipped). For 5 seconds after the ignition switch is in the ON position, the system does not activate the warning light for the front passenger.

If the light blinks or illuminates even if the driver's and front passenger's seat belts are fastened, it may indicate that the pre-crash seat belt system (if so equipped) has a malfunction. Have an INFINITI dealer check and repair the system.

See "Seat belts" in the "1. Safety — Seats, seat belts and supplemental restraint system" section for precautions on seat belt usage.



Supplemental air bag warning light

After turning the ignition switch to the ON position, the supplemental air bag warning light will illuminate. The supplemental air bag warning light will turn off

after about 7 seconds if the system is operational.

If any of the following conditions occur, the supplemental front air bag, supplemental side air bag and curtain side-impact air bag systems, and pre-tensioner seat belt need servicing and your vehicle must be taken to your an INFINITI dealer.

- The supplemental air bag warning light remains on after approximately 7 seconds.
- The supplemental air bag warning light flashes intermittently.
- The supplemental air bag warning light does not come on at all.

Unless checked and repaired, the Supplemental Restraint System and/or the pretensioner seat belt may not function properly. For additional information, see "Supplemental restraint system" in the "1. Safety — Seats, restraints and supplemental restraint system" section.



WARNING

If the supplemental air bag warning light is on, it could mean that the supplemental

front air bag, supplemental side air bag, curtain side-impact air bag systems and/or pretensioner seat belt systems will not operate in an accident. To help avoid injury to yourself or others, have your vehicle checked by an INFINITI dealer as soon as possible.

INDICATOR LIGHTS



Automatic transmission position indicator light

When the ignition switch is turned to the ON position, the indicator in the instrument panel shows the automatic transmission selector lever position. See "Driving with automatic transmission" in the "5. Starting and driving" section.



Cruise main switch indicator light

The light comes on when the cruise control main switch is pushed. The light goes out when the main switch is pushed again. When the cruise main switch indicator light comes on, the cruise control system is operational.

Cruise set switch indicator light

The light comes on while the vehicle speed is controlled by the cruise control system. If the light blinks while the engine is running, it may indicate the cruise control system is not functioning properly. Have the system checked by an INFINITI dealer.

Front passenger air bag status light

The front passenger air bag status light, located on the center display, will be lit and the passenger front air bag will be off depending on how the front passenger seat is being used.

For front passenger air bag status light operation, see “INFINITI advanced air bag system” in the “1. Safety — Seats, seat belts and supplemental restraint system” section of this manual.

High beam indicator light (Blue)

This light comes on when the headlight high beam is on and goes out when the low beam is selected.

Malfunction indicator lamp (MIL)

If the malfunction indicator lamp (MIL) comes on steady or blinks while the engine is running, it may indicate a potential emission control malfunction.

The malfunction indicator lamp may also come on steady if the fuel-filler cap is loose or missing, or if the vehicle runs out of fuel. Check to make sure the fuel-filler cap is installed and closed tightly, and that the vehicle has at least three gallons (14 liters) of fuel in the fuel tank.



After a few driving trips, the  lamp should turn off if no other potential emission control system malfunction exists.

If this indicator lamp comes on steady for 20 seconds and then blinks for 10 seconds when the engine is not running, it indicates that the vehicle is not ready for an emission control system inspection/maintenance test. See “Readiness for inspection/maintenance (I/M) test” in the “9. Technical and consumer information” section of this manual.

Operation

The malfunction indicator lamp will come

on in one of two ways:

- Malfunction indicator lamp on steady — An emission control system malfunction has been detected. Check the fuel-filler cap. If the fuel-filler cap is loose or missing, tighten or install the cap and continue to drive the vehicle. The  lamp should turn off after a few driving trips. If the  lamp does not turn off after a few driving trips, have the vehicle inspected by an INFINITI dealer. You do not need to have your vehicle towed to the retailer.
- Malfunction indicator lamp blinking — An engine misfire has been detected which may damage the emission control system. To reduce or avoid emission control system damage:
 - a) Do not drive at speeds above 45 MPH (72 km/h).
 - b) Avoid hard acceleration or deceleration.
 - c) Avoid steep uphill grades.
 - d) If possible, reduce the amount of cargo being hauled or towed.

The malfunction indicator lamp may stop blinking and come on steady.

Have the vehicle inspected by an INFINITI dealer. You do not need to have your vehicle towed to the retailer.



CAUTION

Continued vehicle operation without having the emission control system checked and repaired as necessary could lead to poor driveability, reduced fuel economy, and possible damage to the emission control system.

SLIP Slip indicator light

The light will blink when the vehicle dynamic control (VDC) system is operating, thus alerting the driver to the fact that the road surface is slippery and the vehicle is nearing its traction limits.

This light also comes on when the ignition switch is turned to the ON position. The light will turn off if the VDC is operational.

SNOW Snow mode indicator light (if so equipped)

When selecting SNOW mode while the engine is running, this light will illuminate.

See “SNOW MODE SWITCH” in the “2. Instruments and controls” section.



Turn signal/hazard indicator lights

The light flashes when the turn signal switch lever or hazard switch is turned on.



Vehicle Dynamic Control (VDC) off indicator light

The light comes on when the vehicle dynamic control (VDC) off switch is pushed to OFF. This indicates that the VDC system is not operating.

This light also comes on when the ignition switch is turned to the ON position. The light will turn off if the VDC system is operational.

When the VDC off indicator light and slip indicator light come on with the VDC system turned on, this light alerts the driver to the fact that the VDC system fail-safe mode is operating and the system may not be functioning properly. Have the system checked by an INFINITI dealer. If a malfunction occurs in the system, the VDC system function will be canceled but the vehicle is still driveable. For additional in-

formation, see “Vehicle Dynamic Control (VDC) system” in the “5. Starting and driving” section of this manual.

AUDIBLE REMINDERS

Key reminder chime

The chime will sound if the driver’s side door is opened while the key is left in the ignition switch (ignition switch is turned off). Remove the key and take it with you when leaving the vehicle.

Light reminder chime

The chime will sound when the front door is opened with the headlight switch on unless the ignition switch is in the ON position.

Make sure to turn the light switch off when you leave the vehicle.

Brake pad wear warning

The disc brake pads have audible wear warnings. When a brake pad requires replacement, it will make a high pitched scraping sound when the vehicle is in motion whether or not the brake pedal is depressed. Have the brakes checked as soon as possible if the warning sound is heard.

SECURITY SYSTEMS

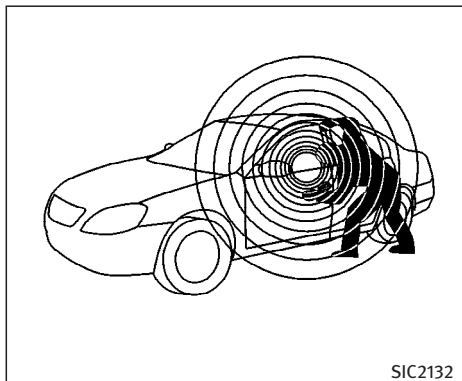

Your vehicle has two types of security systems, as follows:

- Vehicle Security System
- INFINITI Vehicle Immobilizer System

The security condition will be shown by the security indicator light.

VEHICLE SECURITY SYSTEM

The vehicle security system provides visual and audible alarm signals if someone opens the doors, hood, or trunk lid when the system is armed. It is not, however, a motion detection type system

that activates when a vehicle is moved or when a vibration occurs.

The system helps deter vehicle theft but cannot prevent it, nor can it prevent the theft of interior or exterior vehicle components in all situations. Always secure your vehicle even if parking for a brief period. Never leave your keys in the vehicle, and always lock it when unattended. Be aware of your surroundings, and park in secure, well-lit areas whenever possible.

Many devices offering additional protection, such as component locks, identification markers, and tracking systems, are available at auto supply stores and specialty shops. An INFINITI dealer may also offer such equipment. Check with your insurance company to see if you may be eligible for discounts for various theft protection features.

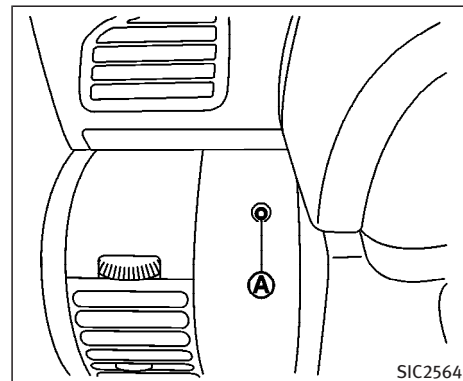

How to arm the vehicle security system

1. Close all windows.

The system can be armed even if the windows are open.

2.
 - Remove the key from the ignition switch.
 - Turn the ignition switch to the LOCK position or remove the mechanical key from the ignition switch (Intelligent Key equipped model).

3. Close and lock all doors, hood and trunk lid.

Lock all doors by pushing the LOCK  button on the keyfob, the Intelligent Key or by pushing any front door handle request switch or turning the door key. When using the remote keyless entry, the hazard indicators will operate as shown in “Remote keyless entry system” or “Intelligent Key system” in the “3. Pre-driving checks and adjustments” section.

4. Confirm that the security indicator light  comes on. The security indicator light glows for about 30 seconds and then blinks. The system is now armed. If, during this 30-second time period, the door is unlocked by the key, the remote keyless entry or the front door request switch, or the ignition switch is turned to the ACC or ON position, the system will not be armed.

Even when the driver and/or passengers are in the vehicle, the system will be armed with all doors, hood and trunk lid locked and ignition switch off. Turn the ignition switch to the ACC position to turn off the system.

Vehicle security system activation

The security system will give the following alarm:

- The headlights blink and the horn sounds intermittently.
- The alarm automatically turns off after approximately 50 seconds. However, the alarm reactivates if the vehicle is tampered with again. The alarm can be shut off by unlocking a door with the key, by pushing any front door handle request switch or by pushing the UNLOCK  button on the keyfob or Intelligent Key.

The alarm is activated by:

- Opening the door without using the key or keyfob or Intelligent Key.
- Opening the trunk lid without using the keyfob or Intelligent Key.
- Opening the hood.

How to stop an activated alarm

The alarm will stop only by unlocking a door with the key, by pushing any door handle request switch or by pushing the UNLOCK  button on keyfob or Intelligent Key. The alarm will not stop if the ig-

nition switch is turned to the ACC or ON position.

If the system does not operate as described above, have it checked by an INFINITI dealer.

INFINITI VEHICLE IMMOBILIZER SYSTEM

The INFINITI Vehicle Immobilizer System will not allow the engine to start without the use of the registered key.

If the engine fails to start using the registered key (for example, when interference is caused by another registered key, an automated toll road device or automated payment device on the key ring), restart the engine using the following procedures:

1. Leave the ignition switch in the ON position for approximately 5 seconds.
2. Turn the ignition switch to the OFF or LOCK position and wait approximately 10 seconds.
3. Repeat steps 1 and 2.
4. Restart the engine while holding the device (which may have caused the in-

terference) separate from the registered key.

If this procedure allows the engine to start, INFINITI recommends placing the registered key on a separate key ring to avoid interference from other devices.

Statement related to section 15 of FCC rules for INFINITI Vehicle Immobilizer System (CONT ASSY-BCM, ANT ASSY-IMMOBILIZER)

This device complies with part 15 of the FCC Rules and RSS-210 of Industry Canada. Operation is subject to the following two conditions;

(1) This device may not cause harmful interference, and (2) this device must accept any interference received, including interference that may cause undesired operation of the device.

CHANGES OR MODIFICATIONS NOT EXPRESSLY APPROVED BY THE PARTY RESPONSIBLE FOR COMPLIANCE COULD VOID THE USER'S AUTHORITY TO OPERATE THE EQUIPMENT.

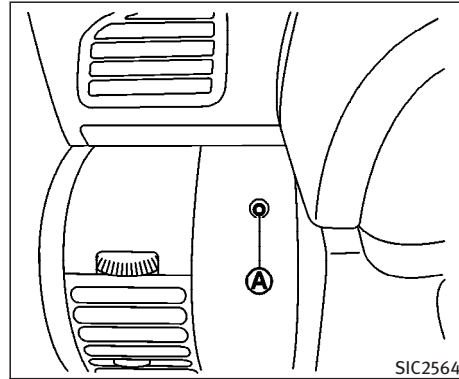

Security indicator light

If INFINITI Vehicle Immobilizer System is malfunctioning, indicator light **(A)** will remain on while the ignition switch is in the ON position.

If the light still remains on and/or the engine will not start, see an INFINITI dealer for INFINITI Vehicle Immobilizer System service as soon as possible. Bring all registered keys that you have when visiting an INFINITI dealer for service.

WINDSHIELD WIPER AND WASHER SWITCH

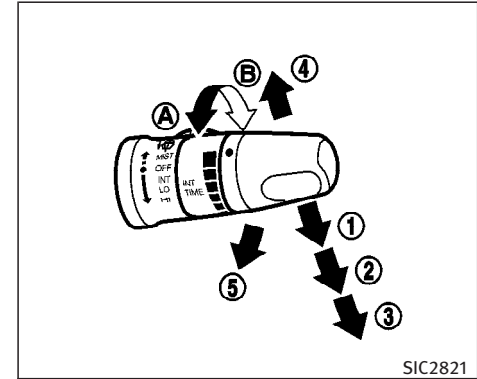

The windshield wiper and washer operates when the ignition switch is in the ON position.

Push the lever down to operate the wiper at the following speed:

- ① Intermittent — intermittent operation can be adjusted by turning the knob toward **(A)** (Slower) or **(B)** (Faster). Also, the intermittent operation speed varies in accordance with the vehicle speed. (For example, when the vehicle speed is high, the intermittent operation speed will be faster.)

- ② Low — continuous low speed operation
- ③ High — continuous high speed operation

Push the lever up ④ to have one sweep operation of the wiper.

Pull the lever toward you ⑤ to operate the washer. Then the wiper will also operate several times.



CAUTION

- Do not operate the washer continuously for more than 30 seconds.
- Do not operate the washer if the reservoir tank is empty.
- Do not fill the window washer reservoir tank with washer fluid concentrates at full strength. Some methyl alcohol based washer fluid concentrates may permanently stain the grille if spilled while filling the window washer reservoir tank.
- Pre-mix washer fluid concentrates with water to the manufacturer's recom-

mended levels before pouring the fluid into the window washer reservoir tank. Do not use the window washer reservoir tank to mix the washer fluid concentrate and water.



WARNING

In freezing temperatures the washer solution may freeze on the windshield and obscure your vision which may lead to an accident. Warm the windshield with the defroster before you wash the windshield.

REAR WINDOW AND OUTSIDE MIRROR DEFROSTER SWITCH

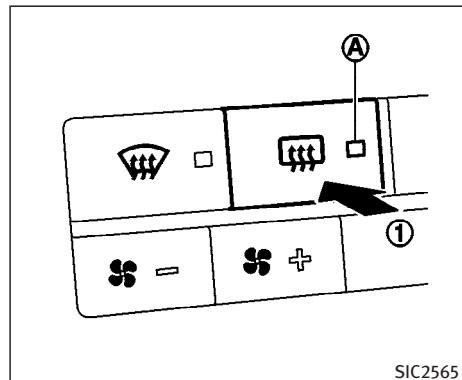

To defog/defrost the rear window glass and outside mirrors, start the engine and push the switch ① on. The indicator light ① will come on. Push the switch again to turn the defroster off.

It will automatically turn off in approximately 15 minutes.



CAUTION

When cleaning the inner side of the rear window, be careful not to scratch or damage the rear window defroster.

HEADLIGHT AND TURN SIGNAL SWITCH

XENON HEADLIGHTS



WARNING



HIGH VOLTAGE

- When xenon headlights are on, they produce a high voltage. To prevent an electric shock, never attempt to modify or disassemble. Always have your xenon headlights replaced at an INFINITI dealer.
- Xenon headlights provide considerably more light than conventional headlights. If they are not correctly aimed, they might temporarily blind an oncoming driver or the driver ahead of you and cause a serious accident. If headlights are not aimed correctly, immediately take your vehicle to an INFINITI dealer and have the headlights adjusted correctly.

When the xenon headlight is initially turned on, its brightness or color varies slightly. However, the color and brightness will soon stabilize.

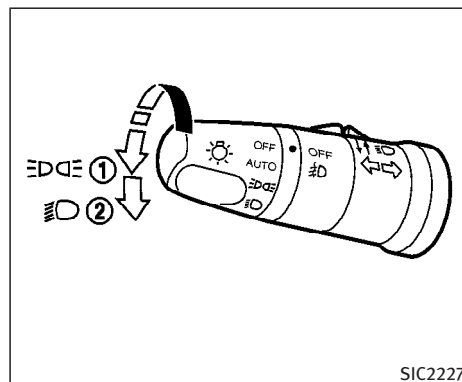

- The life of xenon headlights will be shortened by frequent on-off operation. It is generally desirable not to turn off the headlights for short intervals (for example, when the vehicle stops at a traffic signal). Even when the daytime running lights are active (Canada only), the xenon headlights do not turn on. This way the life of the xenon headlights is not reduced.
- If a xenon headlight bulb is close to burning out, the brightness will drastically decrease, the light will start blinking, or the color of the light will become reddish. If one or more of the above signs appear, contact an INFINITI dealer.



Type A

HEADLIGHT SWITCH

Lighting

- ① Turn the switch to the  position:
The front park, side marker, tail, license plate and instrument lights will come on.
- ② Turn the switch to the  position:
Headlights will come on and all the other lights remain on.

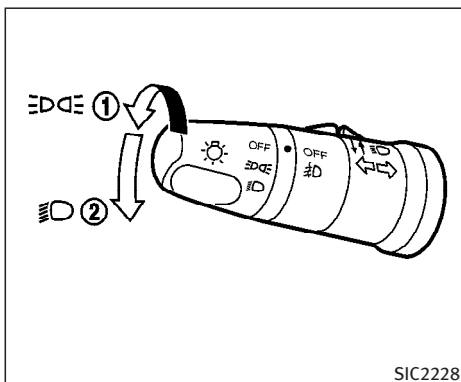

Type B



CAUTION

Use the headlights with the engine running to avoid discharging the vehicle battery.

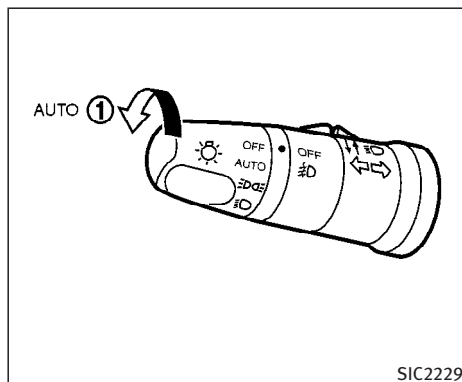



Autolight system

Autolight system (if so equipped)

The autolight system allows the headlights to be set so they turn on and off automatically.

To set the autolight system:

1. Make sure the headlight switch is in the AUTO ① position.
2. Turn the ignition switch to the ON position.
3. The autolight system automatically turns the headlights on and off.

To turn the autolight system off, turn the switch to the OFF,  or  position.

The autolight system can turn on the headlights automatically when it is dark, turn off the headlights when it is light, and keep the headlights on for up to 45 seconds after you turn the ignition switch to the OFF position and open any door then close all the doors.

If the ignition switch is turned off and one of the doors is opened and this condition is continued, the headlights remain on for 5 minutes.

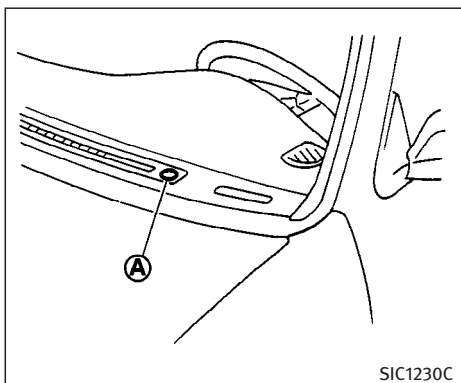



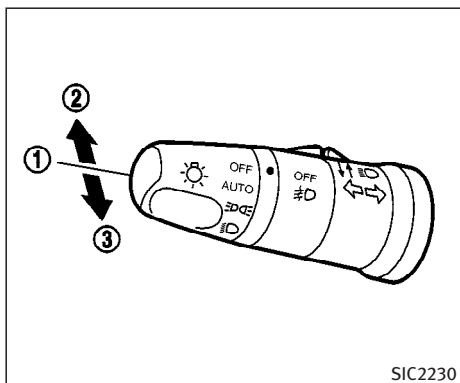



Be sure not to put anything on top of the photo sensor **A** located on the top left-hand side of the instrument panel. The photo sensor controls the autolamp; if it is covered, the photo sensor reacts as if it is dark and the headlights will illuminate.



Headlight beam select

- ① To select the low beam, put the lever in the neutral position as shown.
- ② To select the high beam, push the lever forward while the switch is in the  position. Pull it back to select the low beam.
- ③ Pulling the lever toward you will flash the headlight high beam even when the headlight switch is in the OFF position.

Battery saver system



- When the headlight switch is in the  or  position while the ignition switch is in the ON position, the lights (including the front fog light) will automatically turn off 5 minutes after the ignition switch has been turned to the OFF position.
- When the headlight switch remains in the  or  position after the lights automatically turn off, the lights will turn on for 5 minutes when the headlight switch is turned to the OFF position and then turned to the  or  position.



CAUTION

Even though the battery saver feature automatically turns off the headlights after a period of time, you should turn the headlight switch to the OFF position when the engine is not running to avoid discharging the vehicle battery.

Daytime running light system (Canada only)

The headlights automatically illuminate at a reduced intensity when the engine is started with the parking brake released. The daytime running lights operate with the headlight switch in the OFF position or in the  position. Turn the headlight switch to the  position for full illumination when driving at night.

If the parking brake is applied before the engine is started, the daytime running lights do not illuminate. The daytime running lights illuminate once the parking brake is released. The daytime running lights will remain on until the ignition switch is turned off.



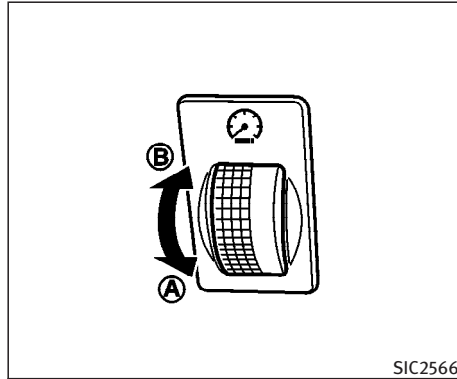

WARNING

When the daytime running light system is active, tail lights on your vehicle are not on. It is necessary at dusk to turn on your headlights. Failure to do so could cause an accident injuring yourself and others.



Instrument brightness control

The instrument brightness control operates when the light switch is in the AUTO (when lighting),  or  position. Turn the control to the darkening direction **A** or the brightening direction **B** to adjust the brightness of the instrument panel (except power window switch lights).

When the control is turned to the upper end, the light intensity will be at maximum. When the control is turned to the lower end, the light will be turned off.

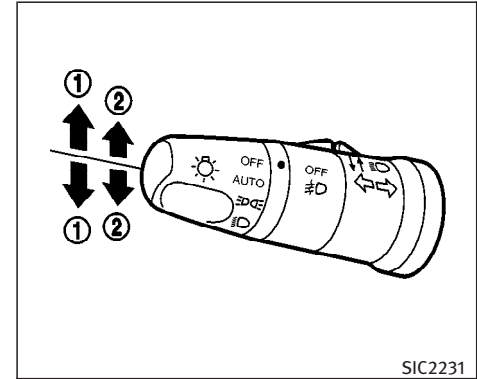

TURN SIGNAL SWITCH

Turn signal

① Turn signal

Move the lever up or down to signal the turning direction. When the turn is completed, the turn signals cancel automatically.



② Lane change signal

To indicate a lane change, move the lever up or down to the point where lights begin flashing.

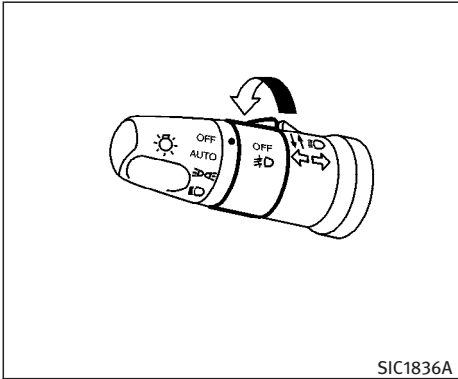
HAZARD WARNING FLASHER SWITCH



FOG LIGHT SWITCH

To turn the fog lights on, turn the headlight switch to the  position, then turn the switch to the  position. To turn them off, turn the switch to the OFF position.

The headlights must be on and the low beams selected for the fog lights to operate. The fog lights automatically turn off when the high beam headlights are selected.

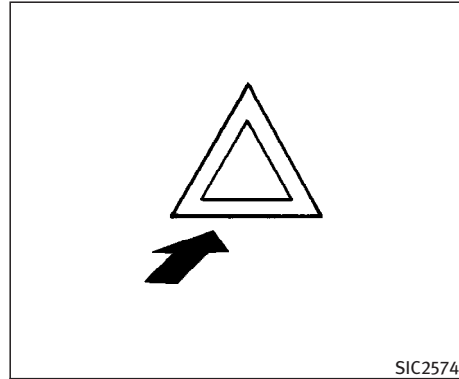

Push the switch on to warn other drivers when you must stop or park under emergency conditions. All turn signal lights will flash.

Some state or provincial laws may prohibit the use of the hazard warning flasher switch while driving.



WARNING

- If stopping for an emergency, be sure to move the vehicle well off the road.

- Do not use the hazard warning flashers while moving on the highway unless unusual circumstances force you to drive so slowly that your vehicle might become a hazard to other traffic.
- Turn signals do not work when the hazard warning flasher lights are on.

The flasher can be actuated with the ignition switch either off or on.

HORN

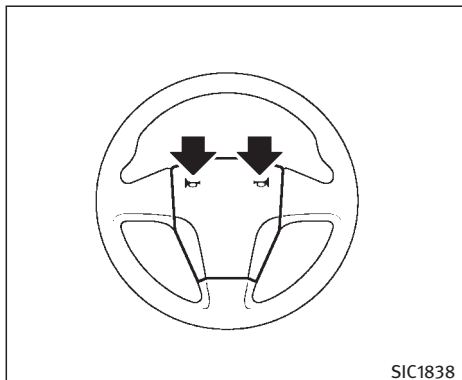

To sound the horn, push on or near the horn marks of the steering wheel.



WARNING

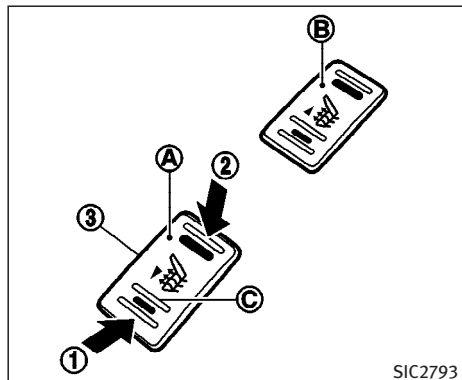

Do not disassemble the horn. Doing so could affect proper operation of the supplemental front air bag system. Tampering with the supplemental front air bag system may result in serious personal injury.

HEATED SEATS



AT models

The front seats are warmed by built-in heaters. The switches located on the center console can be operated independently (driver side seat **A**) and front passenger seat **B**) of each other.

1. Start the engine.
2. Select heat range.
 - ① For low heat, push the  (Low) side of the switch.
 - ② For high heat, push the  (High) side of the switch.
 - ③ For no heat, the switch has a cen-

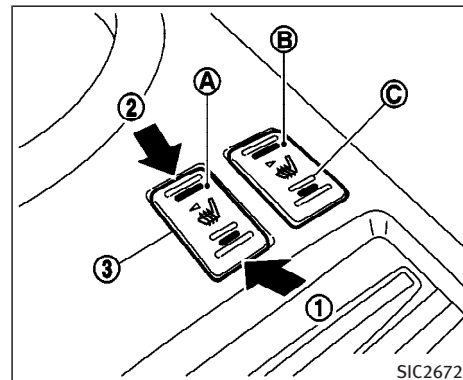

MT models

ter OFF position between low and high.

The indicator light in the switch **C** will illuminate when low or high is selected.

The heater is controlled by a thermostat, automatically turning the heater on and off. The indicator light will remain on as long as the switch is on.

3. When the vehicle's interior is warmed, or before you leave the vehicle, be sure to turn the switch to the off position **③**.



CAUTION

- The battery could run down if the seat heater is operated while the engine is not running.
- Do not use the seat heater for extended periods or when no one is using the seat.
- Do not put anything on the seat which insulates heat, such as a blanket, cushion, seat cover, etc. Otherwise, the seat may become overheated.
- Do not place anything hard or heavy on the seat or pierce it with a pin or similar object. This may result in damage to the heater.
- Any liquid spilled on the heated seat should be removed immediately with a dry cloth.
- When cleaning the seat, never use gasoline, benzine, thinner, or any similar materials.

- If any abnormalities are found or the heated seat does not operate, turn the switch off and have the system checked by an INFINITI dealer.

SNOW MODE SWITCH (if so equipped)

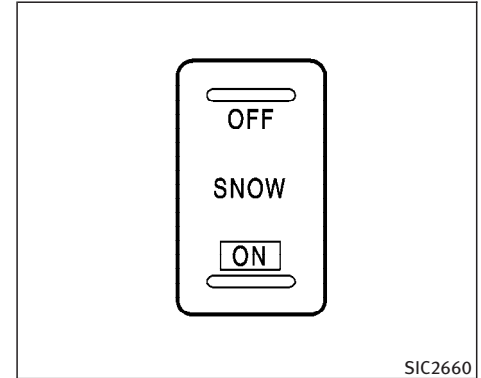

For driving or starting the vehicle on snowy roads or slippery areas, push the **SNOW** mode switch to the ON position and then the indicator light in the switch and the SNOW indicator light in the instrument panel will illuminate. When the SNOW mode is activated, engine output is controlled to reduce wheel spin.



CAUTION

When turning the vehicle in **SNOW** mode on paved roads, you may feel a braking effect. This is a normal condition of the AWD model.

VEHICLE DYNAMIC CONTROL (VDC) OFF SWITCH

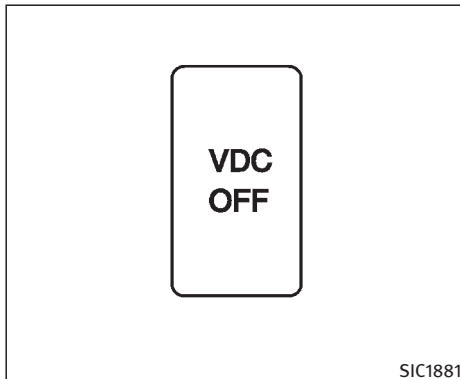

Push the VDC OFF switch again or restart the engine to turn on the system. See “Vehicle Dynamic Control (VDC) system” in the “5. Starting and driving” section.

The vehicle should be driven with the Vehicle Dynamic Control (VDC) system on for most driving conditions.

If the vehicle is stuck in mud or snow, the VDC system reduces the engine output to reduce wheel spin. The engine speed will be reduced even if the accelerator is depressed to the floor. If maximum engine power is needed to free a stuck vehicle, turn the VDC system off.

To turn off the Vehicle Dynamic Control (VDC) system, push the VDC OFF switch (located on the lower side of the instrument panel). The  indicator will come on.

CLOCK

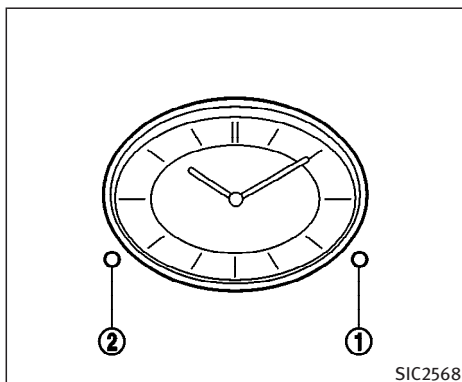

If the power supply is disconnected, the clock will not indicate the correct time. Re-adjust the time.

ADJUSTING THE TIME

To move the time forward, push the button ①.

To move the time backward, push the button ②.

Push and hold each adjusting switch to move the time forward or backward continuously.

POWER OUTLET

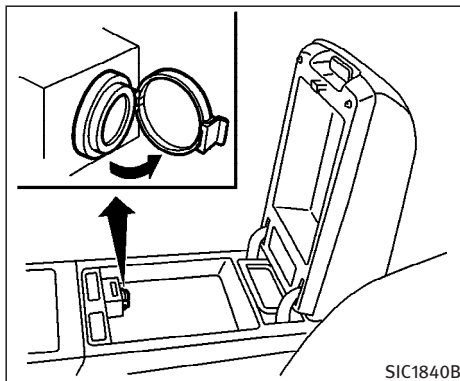

Automatic transmission model

The power outlet is for powering electrical accessories such as cellular telephones.

CAUTION

- The outlet and plug may be hot during or immediately after use.
- This power outlet is not designed for use with a cigarette lighter unit.
- Do not use with accessories that exceed a 12 volt, 120W (10A) power draw. Do not use double adapters or more than one electrical accessory.

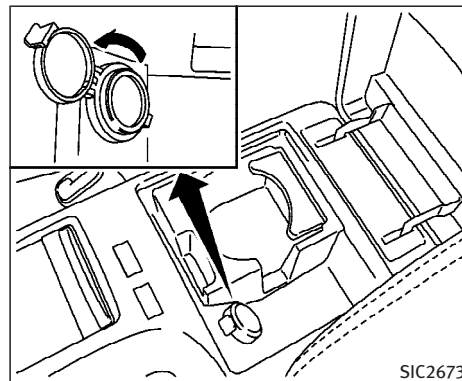

Manual transmission models

- Use power outlets with the engine running to avoid discharging the vehicle battery.
- Avoid using power outlets when the air conditioner, headlights or rear window defroster is on.
- Before inserting or disconnecting a plug, be sure the electrical accessory being used is turned OFF.
- Push the plug in as far as it will go. If good contact is not made, the plug may overheat or the internal temperature fuse may open.
- When not in use, be sure to close the outlet. Do not allow water to contact the outlet.

CIGARETTE LIGHTER AND ASHTRAY

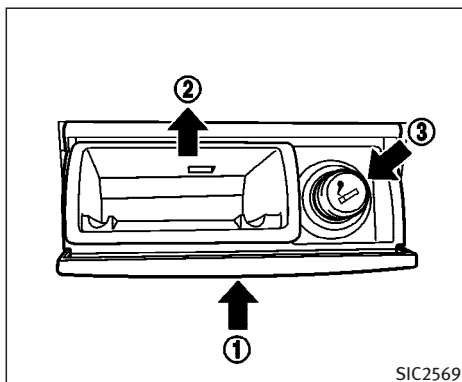

FRONT

To open the ashtray, push ①.

To take out the ashtray, pull out ②.

The cigarette lighter operates when the ignition switch is in the ACC or ON position. To heat the cigarette lighter, push in ③ until it latches. When the lighter is heated, it will spring out automatically.

Return the cigarette lighter to its original position after use.

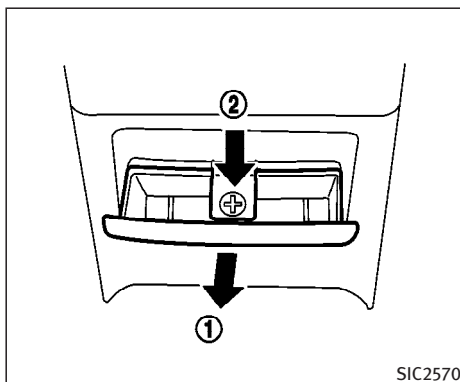

REAR

To open the ashtray, pull ①.

To take out the ashtray, push down ②, and pull out.



WARNING

The cigarette lighter should not be used while driving so full attention may be given to vehicle operation.



CAUTION

The cigarette lighter socket is a power source for the cigarette lighter element only. The use of the cigarette lighter socket as a power source for any other accessory is not recommended. Do not use any other power outlet for an accessory lighter.

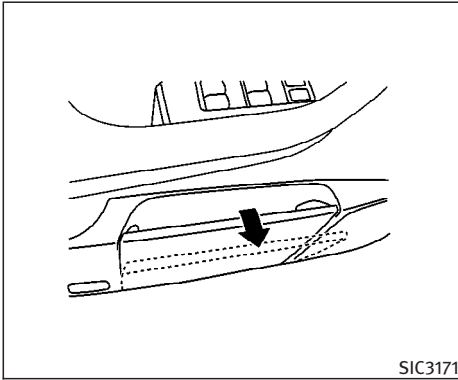

DOOR POCKETS

The door pockets are located on the driver's and front passenger's doors. The door pocket opening can be expanded to make it easier to store and retrieve items. Items stored in the door pocket should not be larger than the door pocket opening in its closed position. Make sure the item does not hold the door pocket in the open position.



CAUTION

Do not store items in the door pocket that are larger than the opening in the closed position. Do not force the door pocket closed if an item holds the door pocket in the open position. Doing so may damage the door pocket.

STORAGE

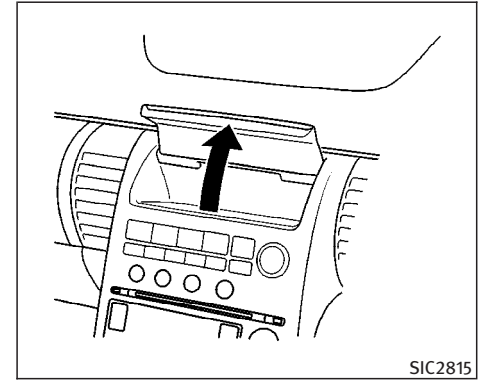

INSTRUMENT POCKET (except for navigation system equipped models)



WARNING

- The instrument pocket should not be used while driving so full attention may be given to vehicle operation.
- Keep the pocket lid closed while driving to help prevent injury in an accident or a sudden stop.

To open the instrument pocket, pull the lid up.

To close, push the lid down.

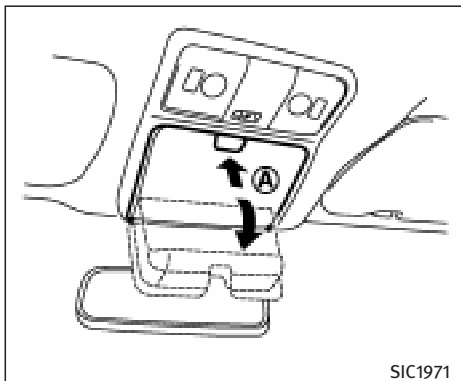

SUNGLASSES HOLDER

The sunglasses holder can be opened by pushing the button (A). To close, push the holder up until the lock latches.

WARNING

- The sunglasses holder should not be used while driving so full attention may be given to vehicle operation.
- Keep the sunglasses holder closed while driving to prevent an accident.

CAUTION

- Do not use for anything other than sunglasses.
- Do not leave sunglasses in the sunglasses holder while parking in direct sunlight. The heat may damage the sunglasses.

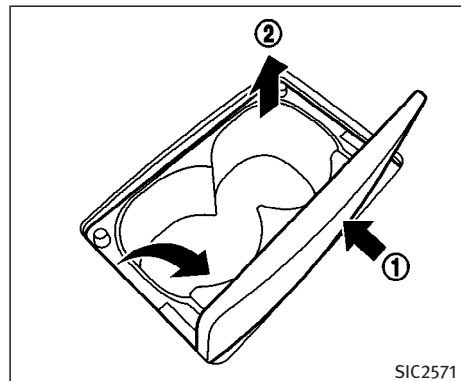

Automatic transmission models — Front CUP HOLDER

WARNING

The cup holder should not be used while driving so full attention may be given to vehicle operation.

Front (Automatic transmission models):

To open the cup holder, push the lid (1).

The flap will be folded down when inserting a large container.

To remove the inner tray for cleaning, pull it up as illustrated ①.

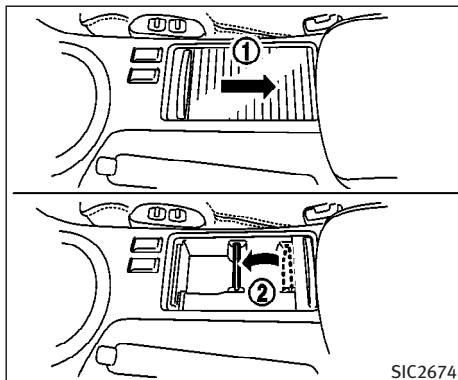

Manual transmission models – Front
Front (Manual transmission models):

To open the cup holder, slide the lid ①.
Install the partition plate into the slit ②.

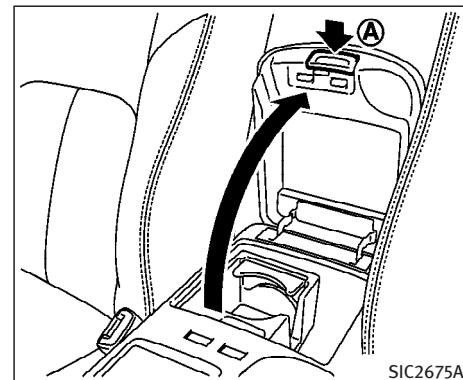

Manual transmission models – Console box
To open the console boxes, push the knob ① and pull up the lid.

To close, push the lid down until the lock latches.

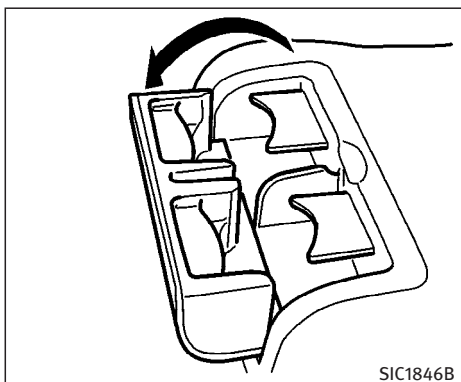

Rear



CAUTION

- Avoid abrupt starting and braking when the cup holder is being used to prevent spilling the drink. If the liquid is hot, it can scald you or your passenger.
- Use only soft cups in the cup holder. Hard objects can injure you in an accident.

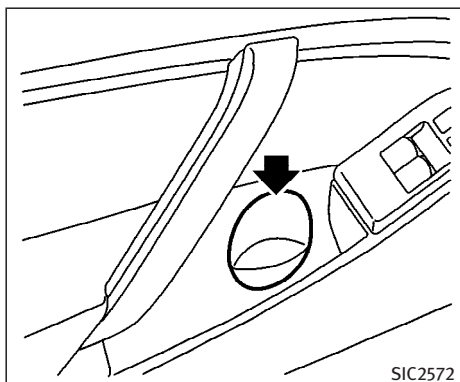

Coupe

Soft bottle holder



CAUTION

- The bottle holder/door pocket should not be used while driving so full attention may be given to vehicle operation.
- Do not use bottle holder for any other objects that could be thrown about in the vehicle and possibly injure people during sudden braking or an accident.

- Do not use bottle holder for open liquid containers.

To open the cup holder, pull the lid.

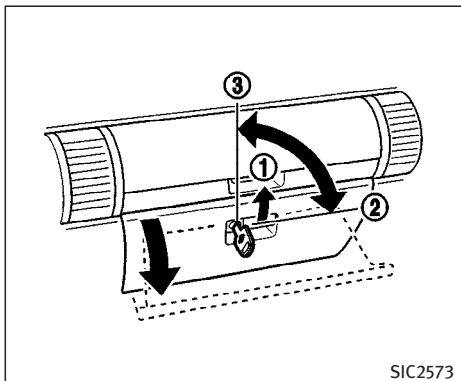

SIC2573

GLOVE BOX

To open the glove box, pull the handle ①.

To close, push the lid in until the lock latches.

To lock ②/unlock ③ the glove box, use the master key.

The glove box light illuminates when the glove box is opened with the headlight switch on.



WARNING

Keep glove box lid closed while driving to help prevent injury in an accident or a sudden stop.

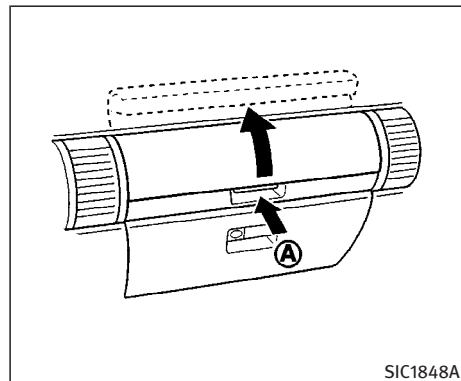

SIC1848A

UPPER GLOVE BOX (except for navigation system equipped models)

To open the upper glove box, push the button ①.

To close, push the lid down until the lock latches.

The upper glove box light illuminates when the upper glove box is opened with the headlight switch on.



WARNING

Keep upper glove box lid closed while driving to help prevent injury in an accident or a sudden stop.

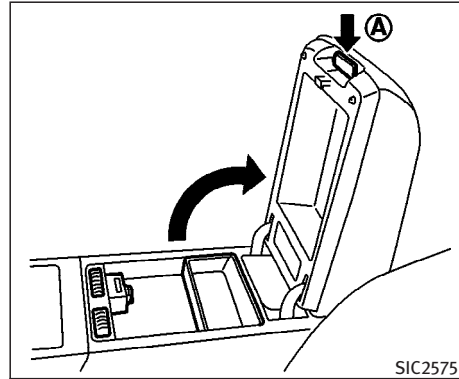

**Automatic transmission model
CONSOLE BOX**

To open the console boxes, push the knob **A** and pull up the lid.

To close, push the lid down until latched.

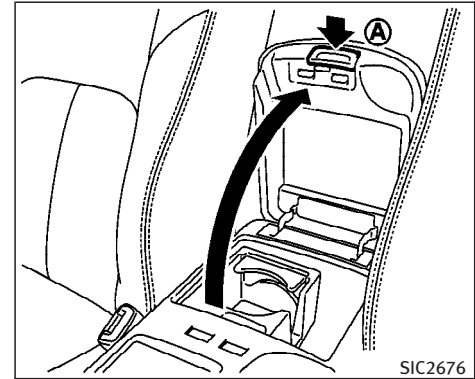

Manual transmission model



WARNING

The center console box should not be used while driving so full attention may be given to vehicle operation.

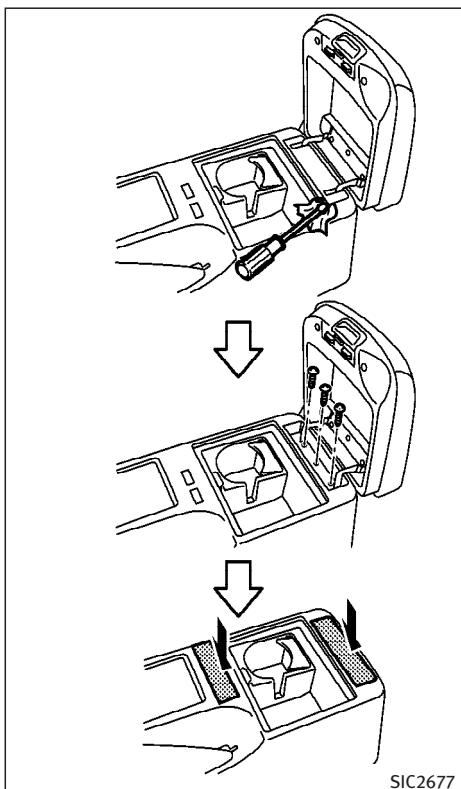

Coupe – Manual transmission model

Coupe (manual transmission model)

To remove the console lid:

1. Remove the original hinge mask. Attach a cloth when using a screwdriver.
2. Loosen 3 screws, and remove the lid.
3. Install the replacement hinge mask and latch cover equipped with coupe manual transmission model.

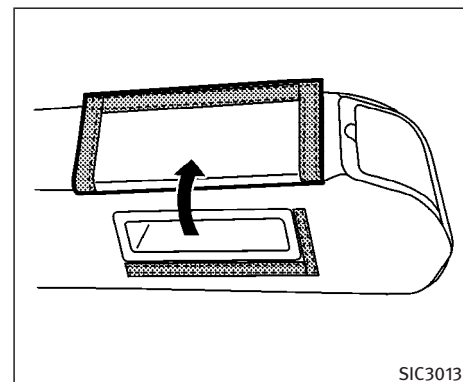

REAR ARMREST POCKET (Sedan)

The pocket can store a first aid kit, etc.



CAUTION

Do not use for heavy articles.

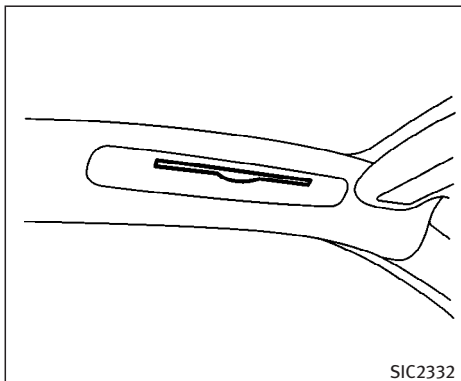

Type A

CARD HOLDER (driver's side)

Type A

Insert a card in the holder.



WARNING

The card holder should not be used while driving so full attention may be given to vehicle operation.

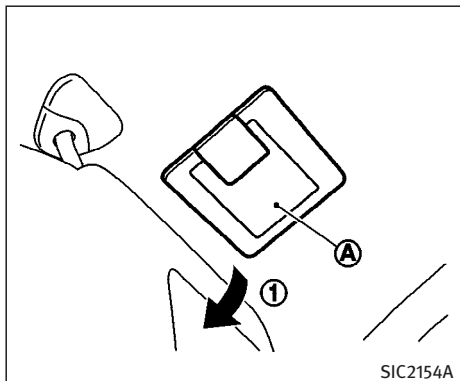

Type B

Type B

Pull the sun visor down ① and slide a card ② in the card holder.

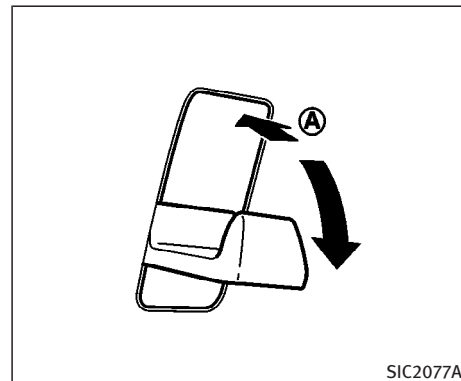

COAT HOOK (Coupe)

To use the coat hook, push the hook ② to release it.



CAUTION

Avoid hanging heavy goods on the hook.

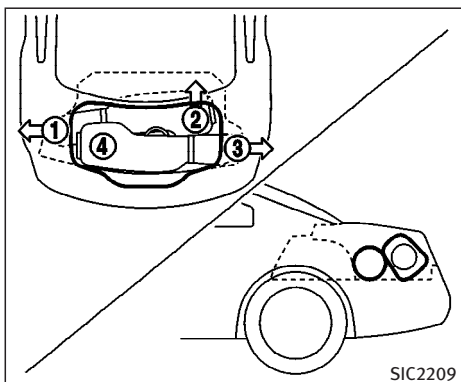

SIC2209

STOWING GOLF BAGS (Coupe)

Normally, two standard golf bags can be stowed in the trunk. Insert the top of the golf bag into left side of the trunk room (1) then put the bag forward (2). Insert the top of the 2nd golf bag into right side of the trunk room (3) and pull it in all the way (4).

In some cases, you may not be able to stow two golf bags in your vehicle, depending on their sizes or types.

WINDOWS

POWER WINDOWS



WARNING

- Make sure that all passengers have their hands, etc. inside the vehicle while it is in motion and before closing the windows. Use the window lock switch to prevent unexpected use of the power windows.
- Do not leave children unattended inside the vehicle. They could unknowingly activate switches or controls and become trapped in a window. Unattended children could become involved in serious accidents.

The power windows operate when the ignition key is in the ON position and for about 45 seconds, after the ignition switch is turned to the OFF position. If the driver's door or the front passenger's door is opened during this period of about 45 seconds, power to the windows is canceled.

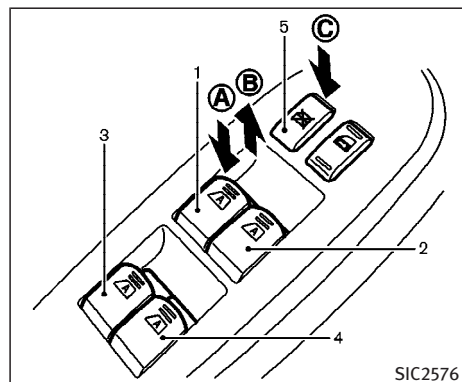

SIC2576

Sedan — Main switch Main power window switch (driver's side)

1. Driver side window
2. Front passenger side window
3. Rear left passenger side window
4. Rear right passenger side window
5. Window lock button

To open or close the window, push down (A) or pull up (B) the switch and hold it. The main switch (driver side switches) will open or close all the windows.

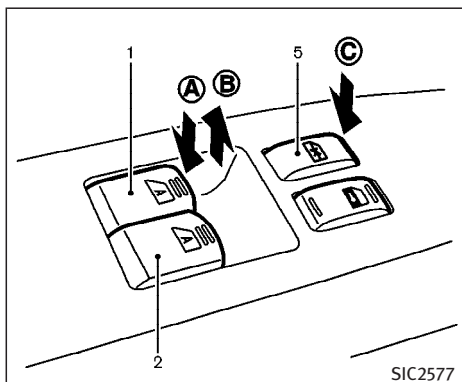

Coupe — Main switch

Locking passenger's windows

When the lock button (C) is pushed in, only the driver side window can be opened or closed. Push it in again to cancel.

SIC2577

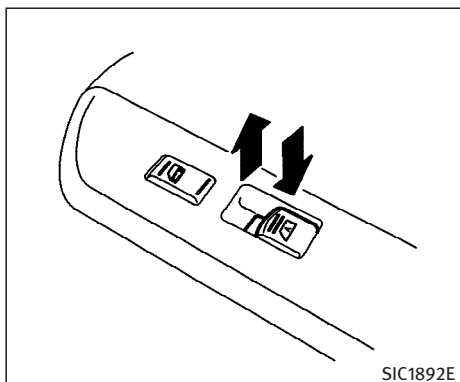

Front passenger side

Passenger side power window switch

The passenger side switch will open or close only the corresponding window. To open or close the window, hold the switch down or up.

SIC1892E

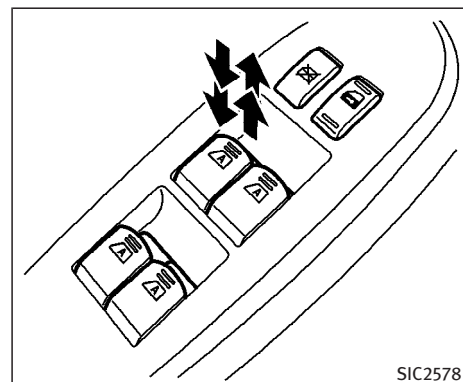

Sedan — Type A

Automatic operation (For front door windows or all door windows, if so equipped)

To fully open or close the window, completely push down or pull up the switch and release it; it need not be held. The window will automatically open or close all the way. To stop the window, just push or lift the switch in the opposite direction.

Auto reverse function (Automatic operation equipped model)

If the control unit detects something

SIC2578

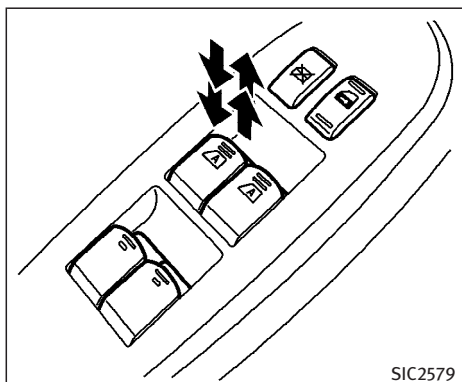

Sedan — Type B

caught in a window as it moves up, the window will be immediately lowered.

The auto reverse function can be activated when a window is closed by automatic operation when the ignition switch is in the ON position, or for about 45 seconds after the ignition switch is turned to the OFF position.

Depending on the environment or driving conditions, the auto reverse function may be activated if an impact or load similar to something being caught in the window occurs.

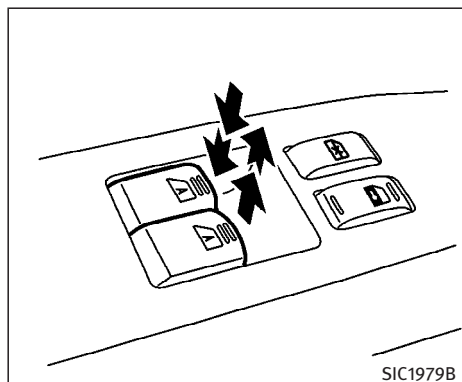

Coupe



WARNING

There are some small distances immediately before the closed position which cannot be detected. Make sure that all passengers have their hands, etc., inside the vehicle before closing the window.

AUTOMATIC ADJUSTING FUNCTION (Coupe)



CAUTION

When the battery cable is removed from the battery terminal, do not close either of the front doors. The automatic window adjusting function will not work, and the side roof panel may be damaged.

The power window has an automatic adjusting function. When the door is being opened, the window is automatically lowered slightly to avoid contact between the window and the side roof panel. When the door is closed, the window is automatically raised slightly.

SUNROOF (if so equipped)

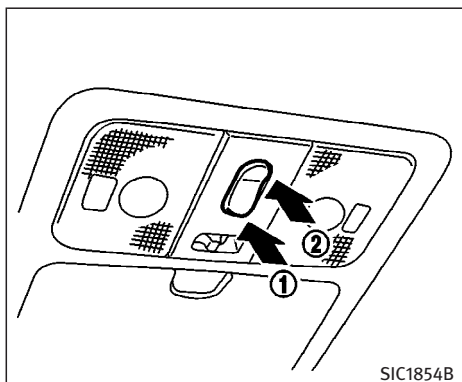

AUTOMATIC SUNROOF

The sunroof will only operate when the ignition switch is in the ON position.

The automatic sunroof is operational for about 45 seconds, even if the ignition switch is turned to the OFF position. If the driver's door or the front passenger's door is opened during this period of about 45 seconds, power to the sunroof is canceled.

Sliding the sunroof

To fully open or close the sunroof, push the switch to the CLOSE ① or OPEN ②

side for less than 1 second and release it; it need not be held. The roof will automatically open or close all the way. To stop the roof, push the switch once more while it is opening or closing.

To open or close the sunroof and stop on the way, push the switch to the CLOSE ① or OPEN ② side for more than 1 second. The roof will stop when releasing the switch.

Auto reverse function (When closing the sunroof)

If the control unit detects something caught in the sunroof when it is closing, the sunroof will immediately move backward.

The auto reverse function can be activated when the sunroof is closed by automatic operation when the ignition switch is in the ON position or for about 45 seconds after the ignition switch is turned to the OFF position.

Depending on the environment or driving conditions, the auto reverse function may be activated if an impact or load similar to something being caught in the sunroof occurs.



WARNING

There are some small distances immediately before the closed position which cannot be detected. Make sure that all passengers have their hands, etc., inside the vehicle before closing the sunroof.

Tilting the sunroof (Sedan)

To tilt up, first close the sunroof, then push and hold the UP ① side of the switch. To tilt down the sunroof, push and hold the DOWN ② side.

Tilting the sunroof (Coupe)

To tilt up, first close the sunroof, then push the UP ① side of the switch and release it; it need not be held. To tilt down the sunroof, push the DOWN ② side.

Sun shade

Open or close the sun shade by sliding it backward or forward.

The shade will open automatically when the sunroof is opened. However, it must be closed manually.



WARNING

- In an accident you could be thrown from the vehicle through an open sunroof. Always use seat belts and child restraints.
- Do not allow anyone to stand up or extend any portion of their body out of the sunroof opening while the vehicle is in motion or while the sunroof is closing.



CAUTION

- Remove water drops, snow, ice or sand from the sunroof before opening.
- Do not place any heavy object on the sunroof or surrounding area.

If the sunroof does not close

If the sunroof does not close or open automatically, use the following procedure to return sunroof operation to normal.

Sedan:

1. Push the switch to the CLOSE/UP side ① to tilt up the sunroof. Release the switch when the sunroof is in the fully tilted up position.
2. Push and hold the switch to the CLOSE/UP ① side for approximately 10 seconds until the sunroof moves automatically. Continue to push and hold the switch while the sunroof operates automatically. Do not release the switch.
3. Release the switch when the sunroof stops.
4. If the sunroof does not operate properly after step 4, repeat the procedure starting with step 1.

Coupe:

1. Push the switch to the CLOSE/UP ① side to tilt up the sunroof.
2. Release the switch when the sunroof is in the fully tilted up position.
3. Push and hold the switch to the CLOSE/UP ① side for approximately 10 seconds until the sunroof automatically closes.

4. Release the switch when the sunroof stops.
5. Push and hold the switch to the CLOSE/UP ① side for approximately 4 seconds until the sunroof moves automatically. Continue to push and hold the switch while the sunroof operates automatically. Do not release the switch.
6. Release the switch when the sunroof stops.
7. If the sunroof does not operate properly after step 6, repeat the procedure starting with step 1.

Have an INFINITI dealer check and repair the sunroof.

INTERIOR LIGHTS

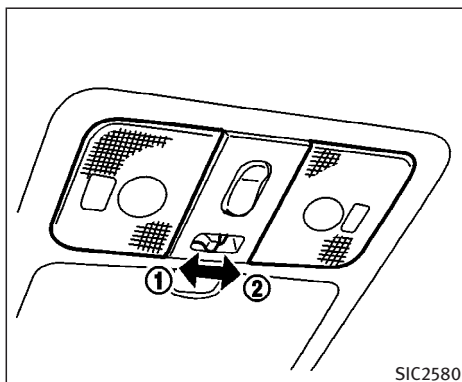

ROOM LIGHT

The room light has a two-position switch.

When the switch is in the door position ①, the room light will illuminate when a door is opened.

The light will stay on for about 30 seconds when:

- The doors are unlocked by the keyfob, a key, power door lock switch or using the Intelligent Key system while all doors are closed.

- The driver's door is opened and then closed while the key is removed from the ignition switch or the ignition is turned to the LOCK position (Intelligent Key system).
- The key is removed from the ignition switch or the ignition is turned to the LOCK position (Intelligent Key system) while all doors are closed.

The light will turn off while the 30 second timer is activated, when:

- The driver's door is locked either with the keyfob, a key or the power door lock switch.
- The ignition switch is turned to the ON position.

When the switch is in the OFF position ②, the room light does not illuminate, regardless of any condition.

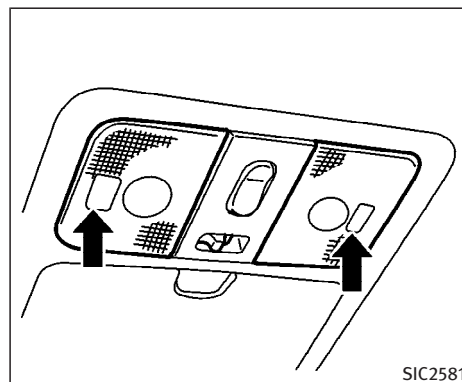

MAP LIGHTS

When the switch is pushed in, the light will turn on. When the switch is pushed again, the light will turn off.

When the map light switch is in the ON position, it will automatically turn off 30 minutes after the ignition switch has been turned to the OFF position. To turn on the light again, turn the ignition switch to the ON position.

The map, personal, and vanity mirror lights will automatically turn off 30 minutes after the latest operation of the fol-

lowing with the ignition switch in the ACC or OFF position:

- Opening or closing any door
- Locking or unlocking with the keyfob, a key, the power door lock switch or the ignition is turned to the LOCK position (Intelligent Key system)
- Inserting or removing a key from the ignition switch

These lights will turn on again when any of the above operations is performed after the lights have turned off automatically. (The lights will turn off 30 minutes after the latest operation of the above as well.)



CAUTION

- Turn off the map, personal and vanity mirror lights when you leave the vehicle.
- Do not use for extended periods of time with the engine stopped. This could result in a discharged battery.

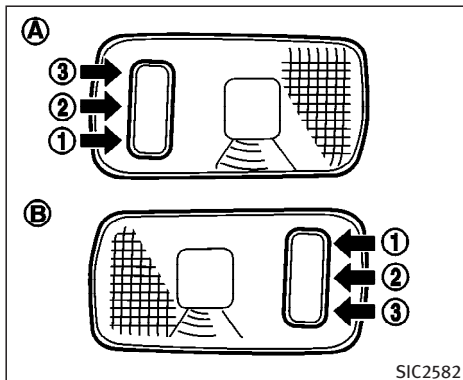

PERSONAL LIGHTS

Rear (Sedan)

- (A): Left-hand side
- (B): Right-hand side

The rear personal light has a three-position switch.

When the switch is in the door position (2), the light will illuminate when the rear door is opened.

When the rear personal light switch is in the ON position (1), the rear personal lights illuminate, regardless of any condition.

When the switch is in the OFF (3) position, the rear personal lights do not illuminate, regardless of any condition.

When the personal light switch is in the ON position, it will automatically turn off 30 minutes after the ignition switch has been turned to the OFF position. To turn on the light again, turn the ignition switch to the ON position.

VANITY MIRROR LIGHT (if so equipped)

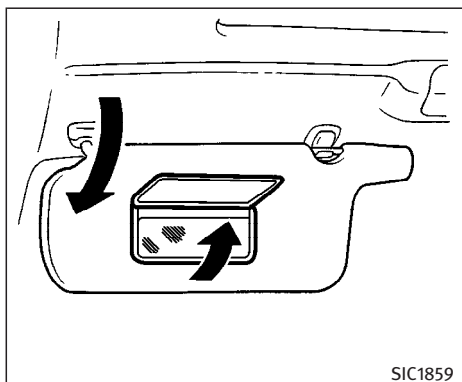

The light on the vanity mirror will turn on when the cover on the vanity mirror is opened.

When the vanity mirror light stays on, it will automatically turn off 30 minutes after the ignition switch has been turned to the OFF position. To turn on the light again, turn the ignition switch to the ON position.

TRUNK LIGHT

The light illuminates when the trunk lid is opened. When the trunk lid is closed, the light will go off.

When the trunk light stays on, it will automatically turn off 30 minutes after the ignition switch has been turned to the OFF position. To turn on the light again, turn the ignition switch to the ON position.

HomeLink® UNIVERSAL TRANSCEIVER (if so equipped)

The HomeLink® Universal Transceiver provides a convenient way to consolidate the functions of up to three individual hand-held transmitters into one built-in device.

HomeLink® Universal Transceiver:

- Will operate most Radio Frequency (RF) devices such as garage doors, gates, home and office lighting, entry door locks and security systems.
- Is powered by your vehicle's battery. No separate batteries are required. If the vehicle's battery is discharged or is disconnected, HomeLink® will retain all programming.

Once the HomeLink® Universal Transceiver is programmed, retain the original transmitter for future programming procedures (i.e., new vehicle purchases). Upon sale of the vehicle, the programmed HomeLink® Universal Transceiver buttons should be erased for security purposes. For additional information, refer to "Programming HomeLink®" later in this section.



WARNING

- Do not use the HomeLink[®] Universal Transceiver with any garage door opener that lacks safety stop and reverse features as required by federal safety standards. (These standards became effective for opener models manufactured after April 1, 1982.) A garage door opener which cannot detect an object in the path of a closing garage door and then automatically stop and reverse, does not meet current federal safety standards. Using a garage door opener without these features increases the risk of serious injury or death.
- During the programming procedure, your garage door or security gate will open or close (if the transmitter is within range). Make sure that people or objects are clear of the garage door, gate, etc. that you are programming.
- Your vehicle's engine should be turned off while programming the HomeLink[®] Universal Transceiver.

PROGRAMMING HomeLink[®]

To program your HomeLink[®] Transceiver to operate a garage door, gate, or entry door opener, home or office lighting, you need to be at the same location as the device. Note: Garage door openers (manufactured after 1996) have “rolling code protection”. To program a garage door opener equipped with “rolling code protection”; you will need to use a ladder to get up to the garage door opener motor to be able to access the “training” program button.

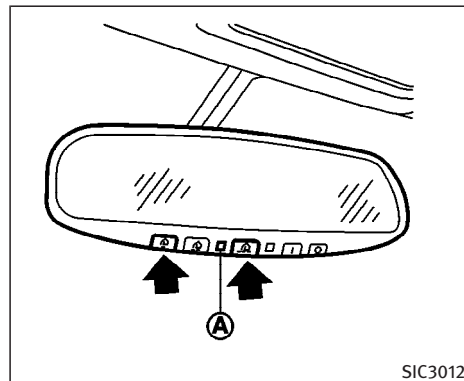

1. To begin, push and hold the 2 outer HomeLink[®] buttons (to clear the memory) until the indicator light (A) blinks (after 20 seconds). Release both buttons.
2. Position the end of the hand-held transmitter 1 - 3 inches (26 - 76 mm) away from the HomeLink[®] surface.

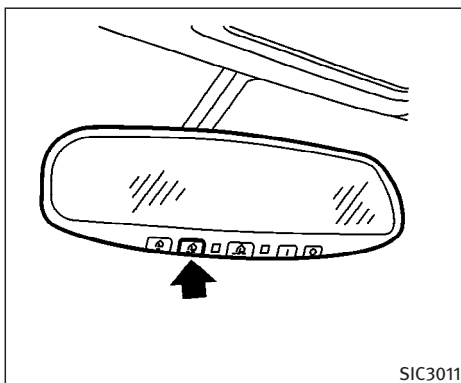

3. Using both hands, simultaneously push and hold both the HomeLink[®] button you want to program and the hand-held transmitter button. DO NOT release the buttons until step 4 has been completed.
4. Hold down both buttons until the indicator light on the HomeLink[®] flashes, changing from a “slow blink” to a “rapid blink”. When the indicator light flashes rapidly, both buttons may be released. The rapidly flashing light indicates successful programming. To activate the garage door or other programmed device, push and hold the

programmed HomeLink[®] button - releasing when the device begins to activate.

5. If the indicator light on the HomeLink[®] blinks rapidly for two seconds and then turns solid, HomeLink[®] has picked up a “rolling code” garage door opener signal. You will need to proceed with the next steps to train the HomeLink[®] to complete the programming which may require a ladder and another person for convenience.
6. Push and release the training button located on the garage door opener’s motor to activate the “training mode”. This button is usually located near the antenna wire that hangs down from the motor. If the wire originates from under a light lens, you will need to remove the lens to access the training button.

NOTE:

Once you have pushed and released the training button on the garage door opener’s motor and the “training light” is lit, you have 30 seconds in which to perform step 7. Use the help of a second person for convenience to assist when performing this step.

7. Quickly within 30 seconds of pushing and releasing the garage door opener program button, firmly push and release the HomeLink[®] button you’ve just programmed. Push and release the HomeLink[®] button up to three times to complete the training.
8. Your HomeLink[®] button should now be programmed.
To program the remaining HomeLink[®] buttons for additional door or gate openers, follow steps 2-8 only.

NOTE:

Do not repeat step one unless you want to “clear” all previously programmed HomeLink[®] buttons.

If you have any questions or are having difficulty programming your HomeLink[®] buttons, refer to the HomeLink[®] web site at: www.homelink.com or call 1-800-355-3515.

PROGRAMMING HomeLink[®] FOR CANADIAN CUSTOMERS

Prior to 1992, D.O.C. regulations required hand-held transmitters to stop transmitting after 2 seconds. To program your hand-held transmitter to HomeLink[®], con-

tinue to push and hold the HomeLink[®] button (note steps 2 through 4 under “Programming HomeLink[®]”) while you push and re-push (“cycle”) your hand-held transmitter every 2 seconds until the indicator light flashes rapidly (indicating successful programming).

NOTE:

If programming a garage door opener, etc., it is advised to unplug the device during the “cycling” process to prevent possible damage to the garage door opener components.

OPERATING THE HomeLink[®] UNIVERSAL TRANSCIVER

The HomeLink[®] Universal Transceiver (once programmed) may now be used to activate the garage door, etc. To operate, simply push the appropriate programmed HomeLink[®] Universal Transceiver button. The red indicator light will illuminate while the signal is being transmitted.

PROGRAMMING TROUBLE-DIAGNOSIS

If the HomeLink[®] does not quickly learn the hand-held transmitter information:

- replace the hand-held transmitter batteries with new batteries.

- position the hand-held transmitter with its battery area facing away from the HomeLink[®] surface.
- push and hold both the HomeLink[®] and hand-held transmitter buttons without interruption.
- position the hand-held transmitter 2 to 5 inches (50 to 127 mm) away from the HomeLink[®] surface. Hold the transmitter in that position for up to 15 seconds. If HomeLink[®] is not programmed within that time, try holding the transmitter in another position - keeping the indicator light in view at all times.

If you continue to have programming difficulties, please contact the INFINITI Consumer Affairs Department. The phone numbers are located in the Foreword of this Owner’s Manual.

CLEARING THE PROGRAMMED INFORMATION

Individual buttons cannot be cleared, however to clear all programming, push and hold the two outside buttons and release when the indicator light begins to flash (approximately 20 seconds).

REPROGRAMMING A SINGLE HomeLink[®] BUTTON

To reprogram a HomeLink[®] Universal Transceiver button, complete the following.

1. Push and hold the desired HomeLink[®] button. **Do not** release the button until step 4 has been completed.
2. When the indicator light begins to flash slowly (after 20 seconds), position the hand-held transmitter 2 to 5 inches (50 to 127 mm) away from the HomeLink[®] surface.
3. Push and hold the hand-held transmitter button.
4. The HomeLink[®] indicator light will flash, first slowly and then rapidly. When the indicator light begins to flash rapidly, release both buttons.

The HomeLink[®] Universal Transceiver button has now been reprogrammed. The new device can be activated by pushing the HomeLink[®] button that was just programmed. This procedure will not affect any other programmed HomeLink[®] buttons.

IF YOUR VEHICLE IS STOLEN

If your vehicle is stolen, you should change the codes of any non-rolling code device that has been programmed into HomeLink[®]. Consult the Owner's Manual of each device or call the manufacturer or dealer of those devices for additional information.

When your vehicle is recovered, you will need to reprogram the HomeLink[®] Universal Transceiver with your new transmitter information.

FCC Notice:

This device complies with FCC rules part 15. Operation is subject to the following two conditions: (1) This device may not cause harmful interference and (2) This device must accept any interference that may be received, including interference that may cause undesired operation.

The transmitter has been tested and complies with FCC and DOC/MDC rules. Changes or modifications not expressly approved by the party responsible for compliance could void the user's authority to operate the device.

DOC: ISTD 1763K1313

FCC I.D.: CB2V67690

2-50 Instruments and controls

3 Pre-driving checks and adjustments

Keys	3-2	Hood	3-24
Infiniti vehicle immobilizer system keys	3-2	Trunk lid	3-25
Doors	3-3	Opener operation	3-25
Locking with key	3-3	Interior trunk lid release.....	3-27
Locking with inside lock knob.....	3-4	Secondary trunk lid release.....	3-27
Locking with power door lock switch.....	3-4	Fuel-filler door.....	3-28
Child safety rear door lock (Sedan)	3-5	Opening the fuel-filler door.....	3-28
Remote keyless entry system (models without Intelligent Key system)	3-5	Fuel-filler cap	3-29
How to use remote keyless entry system	3-6	Steering wheel	3-30
Intelligent Key system (if so equipped).....	3-9	Manual operation	3-30
Door locks/unlocks precaution	3-11	Electric operation (if so equipped)	3-31
Intelligent Key operation	3-11	Sun visors	3-32
Opening and closing windows	3-14	Mirrors.....	3-32
Operating the engine	3-14	Automatic anti-glare inside mirror (if so equipped).....	3-32
Intelligent Key operating range	3-16	Outside mirrors	3-33
Warning signals	3-17	Automatic drive positioner (if so equipped)	3-34
Trouble-shooting guide	3-19	Automatic drive positioner operation.....	3-34
Operation with intelligent remote keyless entry system	3-20	Entry/exit function (if so equipped)	3-34
Operation with the mechanical key and valet key	3-23	Memory storage function.....	3-35
		System operation	3-36
		Cancel switch (if so equipped).....	3-37

KEYS

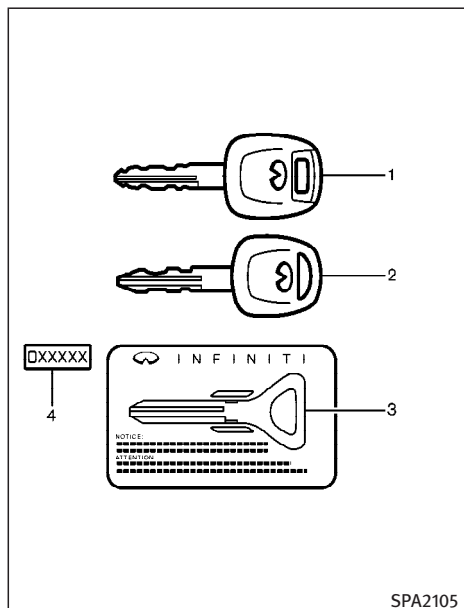

Model without Intelligent Key system

1. Master key 2 sets (With built-in transponder chip), INFINITI MARK: silver
2. Valet key (With built-in transponder chip), INFINITI MARK: Black
3. Wallet key and Key case (Card type)
4. Key number plate

3-2 Pre-driving checks and adjustments

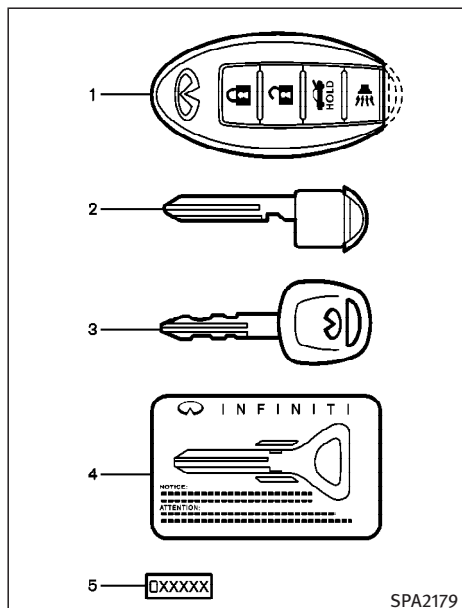

Model with Intelligent Key system

1. Intelligent Key 2 sets*
2. Mechanical key (metal key)* 2 sets
3. Valet key (metal key)
4. Wallet key and key case (card type) (metal key)
5. Key number plate

*: Refer to “Intelligent Key system” later in this section.

A key number plate is supplied with your keys. Record the key number and keep it in a safe place (such as your wallet), not in the vehicle. If you lose your keys, see an INFINITI dealer for duplicates by using the key number.

A key number is necessary when you have lost all keys and do not have one to duplicate from. If you still have a key, an INFINITI dealer can duplicate it.

INFINITI VEHICLE IMMOBILIZER SYSTEM KEYS

You can only drive your vehicle using the master or valet keys which are registered to the INFINITI Vehicle Immobilizer System components in your vehicle. These keys have a transponder chip in the key head.

The master key can be used for all the locks.

The valet key cannot be used for glove box lock and the trunk access window lid lock.

To protect belongings when you leave a key with someone, give them the valet key only.

DOORS

Never leave these keys in the vehicle.

Additional or replacement keys:

If you still have a key, the key number is not necessary when you need extra INFINITI Vehicle Immobilizer System keys. An INFINITI dealer can duplicate it. As many as 5 INFINITI Vehicle Immobilizer System keys can be used with one vehicle. You should bring all registered keys that you have to an INFINITI dealer for registration. This is because the registration process will erase the memory of all key codes previously registered into the INFINITI Vehicle Immobilizer System. After the registration process, these components will only recognize keys coded into the INFINITI Vehicle Immobilizer System during registration. Any key that is not given to your dealer at the time of registration will no longer be able to start your vehicle.

Do not allow the immobilizer system key, which contains an electrical transponder, to come into contact with salt water. This could affect system function.



WARNING

- Always have the doors locked while driving. Along with the use of seat belts, this provides greater safety in the event of an accident by helping to prevent persons from being thrown from the vehicle. This also helps keep children and others from unintentionally opening the doors, and will help keep out intruders.
- Before opening any door, always look for and avoid oncoming traffic.
- Do not leave children unattended inside the vehicle. They could unknowingly activate switches or controls. Unattended children could become involved in serious accidents.

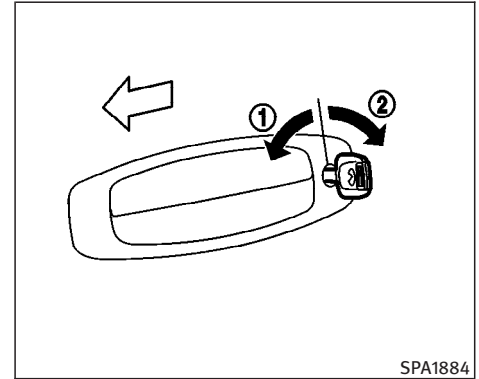

LOCKING WITH KEY

Power

The power door lock system allows you to lock or unlock all doors, trunk lid and the fuel-filler door.

- Turning the door key cylinder to the front of the vehicle (1) will lock all doors, trunk lid and fuel-filler door.
- Turning the door key cylinder to the rear of the vehicle (2) once will unlock the driver's door. Turning the door key cylinder to the rear of the vehicle again within 5 sec-

onds will unlock all doors, the trunk lid and the fuel-filler door.

Opening and closing windows

To open the door windows, turn the door key cylinder to the rear of the vehicle and hold the key for about 1 second.

To stop opening, return the door key cylinder to the neutral position by turning the key.

To close the door windows, turn the door key cylinder to the front of the vehicle and hold the key for about 1 second.

To stop closing, return the door key cylinder to the neutral position by turning the key.

In the event of an obstruction, such as a hand, in the way of door windows, the auto reverse function will activate.

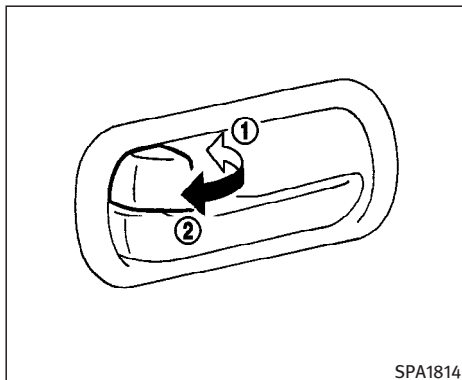

LOCKING WITH INSIDE LOCK KNOB

To individually lock the doors, push the inside lock knob down to the LOCK position ①, then close the door.

When locking the door using inside lock knob, be sure not to leave the key inside of the vehicle.

To unlock, pull the inside lock knob up to the UNLOCK position ②.

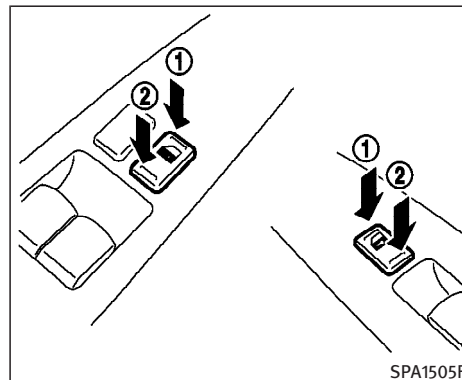

LOCKING WITH POWER DOOR LOCK SWITCH

All doors will be locked when the power door lock switch is pushed to the LOCK position ① with the driver's or front passenger's door open. Then close the door and all doors will be locked.

When locking the door this way, be certain not to leave the key inside the vehicle.

To unlock, push the power door lock switch to the UNLOCK position ②.

Lockout protection

When the power door lock switch (driver or front passenger) is moved to the LOCK position with the key in the ignition and any door open, all doors will lock and unlock automatically. This helps to prevent the keys from being accidentally locked inside the vehicle.

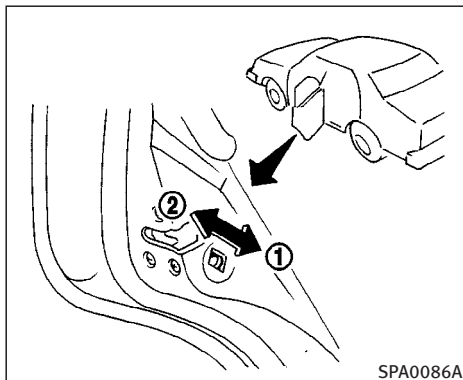

CHILD SAFETY REAR DOOR LOCK (Sedan)

Child safety rear door lock helps prevent rear doors from being opened accidentally, especially when small children are in the vehicle.

When the levers are in the LOCK ① position, the rear doors can be opened by the outside door handles only.

To disengage, move the levers to the unlock position ②.

REMOTE KEYLESS ENTRY SYSTEM (models without Intelligent Key system)

It is possible to lock/unlock all doors, trunk lid and fuel-filler door and activate the panic alarm by using the keyfob from outside the vehicle.

Before locking the doors, make sure the key is not left in the vehicle.

The keyfob can operate at a maximum distance of approximately 33 ft (10 m) away from the vehicle. (The operating distance depends upon the conditions around the vehicle.)

As many as 5 keyfobs can be used with one vehicle. For information about purchase and use of additional keyfobs, contact an INFINITI dealer.

The keyfob will not function when:

- the battery is completely discharged,
- the distance between the vehicle and the keyfob is more than 33 ft (10 m).

The panic alarm will not activate when the key is in the ignition switch.



CAUTION

The following conditions or occurrences may damage the keyfob.

- Do not allow the keyfob to become wet.
- Do not drop the keyfob.
- Do not strike the keyfob sharply against another object.
- Do not place the keyfob for an extended period in an area where temperatures exceed 140°F (60°C).

If a keyfob is lost or stolen, INFINITI recommends erasing the ID code of that keyfob. This will prevent the keyfob from unauthorized use to unlock the vehicle. For information regarding the erasing procedure, please contact an INFINITI dealer.

For information regarding the replacement of a battery, see “Keyfob battery replacement” in the “8. Maintenance and do-it-yourself” section.

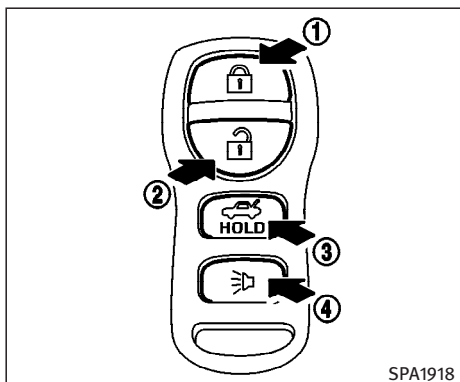

- ① LOCK button
- ② UNLOCK button
- ③ TRUNK button
- ④ PANIC button

HOW TO USE REMOTE KEYLESS ENTRY SYSTEM

Locking doors and fuel-filler door

1. Remove the ignition key.*1,*2
2. Close all doors.*3

3. Push the LOCK button on the keyfob.
4. All doors, the trunk lid and the fuel-filler door will lock.

All doors will lock when the LOCK button on the keyfob is pushed even though a door remains open and/or the ignition switch is in any position.



5. The hazard indicator flashes twice and the horn chirps once.
 - When the LOCK button is pushed with all doors locked, the hazard indicator flashes twice and the horn chirps once as a reminder that the doors are already locked.

*1: Doors lock with the keyfob while a key is in the ignition switch. However, the panic alarm will not activate when the key is in the ignition switch.

*2: Doors lock with the keyfob while the ignition switch is in the ON position. However, the switching indicators will not function.

*3: Doors lock with the keyfob while any door is open. However, the switching indicators will not function.

Unlocking doors and fuel-filler door

1. Push the UNLOCK  button on the keyfob once.
 - The driver's door and fuel-filler door unlock
 - The hazard indicator flashes once if all doors are completely closed with the ignition switch in any position except in the ON position.
 - The interior light timer activates and the interior light comes on for 30 seconds when the interior light switch is at the DOOR position with the ignition switch in any position except in the ON position.
2. Push the UNLOCK  button on the keyfob again within 5 seconds.
 - All doors and trunk lid unlock
 - The hazard indicator flashes once if all doors are completely closed.

All doors will be locked automatically unless one of the following operations is performed within 1 minute of pushing the UNLOCK  button.

- opening any door.

- opening trunk lid.
- turning the ignition switch to the ON position

The interior light can be turned off without waiting for 30 seconds by turning the ignition switch to the ON position or by locking the doors with the keyfob.

Opening the windows

Push the UNLOCK  button on the keyfob.

The driver's door and fuel-filler door will unlock.

Continue to push the UNLOCK  button for more than 3 seconds. The door windows will start to lower.

Continue to push the UNLOCK  button until windows are fully open.

To stop the windows lowering operation, release the UNLOCK  button.

To start the windows lowering operation, push the UNLOCK  button again for more than 3 seconds.

Releasing the trunk lid

1. Push the TRUNK  button on the keyfob for longer than 0.5 seconds





when the ignition switch is in any position except the ON position.



2. The trunk lid opens.

The trunk lid cannot be opened by operating the keyfob when the ignition switch is in the ON position.

Using the panic alarm

If you are near your vehicle and feel threatened, you may activate the alarm to call attention as follows:

1. Push the PANIC  button on the keyfob for **longer than 0.5 seconds** with the key removed from the ignition switch.
2. The theft warning alarm and headlights will stay on for 25 seconds.
3. The panic alarm stops when:
 - It has run for 25 seconds, or
 - The LOCK  button or the UNLOCK  button on keyfob is pushed, or
 - The TRUNK  button or the PANIC  button on the keyfob is pushed for longer than 0.5 second.

OPERATION GUIDE			
MODE (Push "LOCK"  and "UNLOCK"  buttons for more than 2 seconds to switch)	Switching indicator	LOCK	UNLOCK
Hazard indicator and horn mode → HAZARD INDICATOR MODE	HAZARD – 3 times	HAZARD – twice	No operation
Hazard indicator mode → HAZARD INDICATOR AND HORN MODE	HAZARD – once HORN – once	HAZARD – twice HORN – once	HAZARD – once



SPA2180

When pushing the buttons to set hazard indicator only mode, the hazard indicator flashes 3 times.



When pushing the buttons to set hazard indicator and horn mode, the hazard indicator flashes once and the horn chirps once.

Setting hazard indicator and horn mode



The factory setting of the remote keyless entry system is in hazard indicator and horn mode.

In hazard indicator and horn mode, when the LOCK  button is pushed, the hazard indicator flashes twice and the horn chirps once. When the UNLOCK  button is pushed, the hazard indicator flashes once.

If horn chirps are not necessary, the system can be switched to hazard indicator mode.

In hazard indicator mode, when the LOCK  button is pushed, the hazard indicator flashes twice. When the UNLOCK  button is pushed, neither the hazard indicator nor the horn operates.

Switching procedure:

Push the LOCK  button and UNLOCK  button on the keyfob simultaneously for more than 2 seconds to switch from one mode to the other.

3-8 Pre-driving checks and adjustments

INTELLIGENT KEY SYSTEM (if so equipped)

The Intelligent Key uses coded radio signals to communicate with the vehicle. When the Intelligent Key is near the vehicle, such as in your pocket or purse, it allows the vehicle to be locked, unlocked, or started without inserting the ignition key. It is also possible to use the remote control entry function.



CAUTION

- Be sure to carry the Intelligent Key with you.
- Do not leave the vehicle with the Intelligent Key inside.
- The Intelligent Key may not function correctly depending on the environment or operating conditions. It could also malfunction if you do not use it correctly.
- The Intelligent Key transmits faint radio waves.

In the following situations, the Intelligent Key and remote control entry functions may not operate correctly, and you may have to use the metal key (mechanical key, valet key or wallet key):

- when there are strong signals coming from a television tower, power station or broadcasting station.
- when you have wireless equipment or a cellular phone with you.
- when the Intelligent Key is in contact with or covered by a metallic material.
- when radio wave-type remote control entry is used nearby.
- when the Intelligent Key is placed near an electric appliance such as a personal computer.
- The Intelligent Key continually consumes battery power as the key receives a signal to communicate with the vehicle. Battery life is about 2 years, although it varies depending on the operating conditions. When the battery of the Intelligent Key is low, the green blinking key warning light goes out about 30 seconds after the ignition switch is turned to the ON position. If the battery runs down, replace it with a new one.
- If the Intelligent Key receives strong signal over an extended period of time,

the battery could quickly run down. Do not place the Intelligent Key near an electric appliance such as a television set or personal computer.

- Because the ignition switch is electronically controlled, if the battery is completely discharged when the ignition switch is in the LOCK position, the steering lock cannot be released and the ignition switch cannot be turned (including the mechanical key). Be careful not to completely discharge the battery.
- In case the battery is completely discharged, make sure to recharge the battery immediately.

For information regarding the replacement of a battery, see “Keyfob battery replacement” in the “8. Maintenance and do-it-yourself” section.

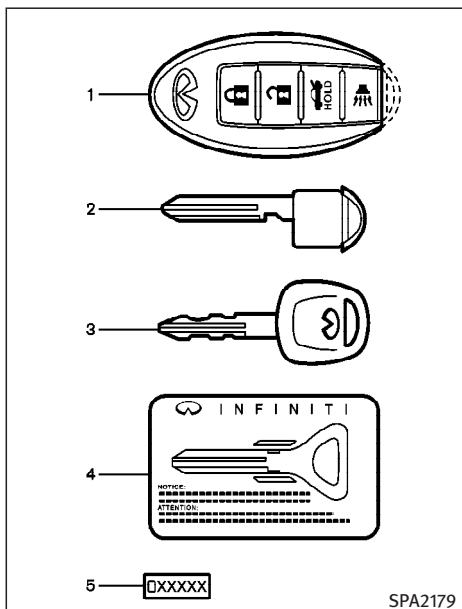

1. Intelligent Key 2 sets
2. Mechanical key (metal key)* 2 sets
3. Valet key (metal key)*
4. Wallet key and key case (card type) (metal key)
5. Key number plate

3-10 Pre-driving checks and adjustments

*: Refer to “INFINITI vehicle immobilizer system keys” earlier in this section.



WARNING

- The Intelligent Key transmits radio waves that can adversely affect medical electric equipment.
- If you have a pacemaker, you should contact the medical equipment manufacturer to ask if it will be affected by the Intelligent Key signal.

The valet key cannot be used for the glove box lock and the trunk access window lid lock.

To protect belongings when you leave a key with someone, give them the valet key only.

Record the key number on the key number plate/metal tag and keep it in a safe place (such as your wallet), NOT IN THE VEHICLE. A key number plate is supplied with your key. Keep the plate in a safe place. INFINITI does not record key numbers so it is very important to keep track of your key number plate.

As many as 4 Intelligent Keys can be used with one vehicle. For information concerning the purchase and use of additional remote controllers, contact an INFINITI dealer.

It is possible that the Intelligent Key functions can become cancelled. Please contact an INFINITI dealer.



CAUTION

Be sure to carry the Intelligent Key with you when driving. The Intelligent Key is a precision device with a built-in transmitter. To avoid damaging it, please note the following.

- The Intelligent Key is water resistant, wetting may damage the Intelligent Key. If the Intelligent Key gets wet, immediately wipe until it is completely dry.
- Do not bend, drop or strike it against another object.
- Do not place the Intelligent Key for an extended period in a place where temperatures exceed 140°F (60°C).

- Do not change or modify the Intelligent Key.
- Do not use a magnet key holder.
- Do not place the Intelligent Key near an electric appliance such as a television set or personal computer.
- Do not place the Intelligent Key in a storage area (for example, a door pocket or glove box). It could be damaged or activated unexpectedly.
- Do not allow the Intelligent Key to come into contact with water or salt water, and do not wash it in a washing machine. This could affect the system function.

If an Intelligent Key is lost or stolen, INFINITI recommends erasing the ID code of that Intelligent Key. This will prevent the Intelligent Key from unauthorized use to unlock the vehicle. For information regarding the erasing procedure, please contact an INFINITI dealer.

DOOR LOCKS/UNLOCKS PRECAUTION

- After locking with the door handle request switch, make sure the doors are securely locked.
- To prevent the Intelligent Key from being left inside the vehicle, make sure you carry the key with you and then lock the doors.
- To prevent the Intelligent Key from being left inside the trunk, make sure you carry the key with you and then close the trunk.
- You can lock or unlock the doors using only the door handle, which detects the Intelligent Key.
- When you try to unlock the door while pulling the door handle, the door may not unlock. In this case, release the door handle and the door will unlock. Pull the door handle again and the door will open.

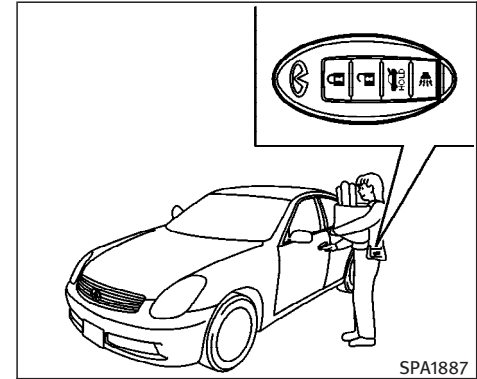

SPA1887

INTELLIGENT KEY OPERATION

You can lock or unlock the doors without taking the key out from your pocket or purse.

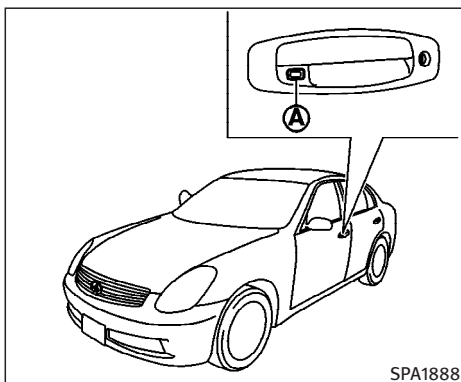

Sedan

SPA1888

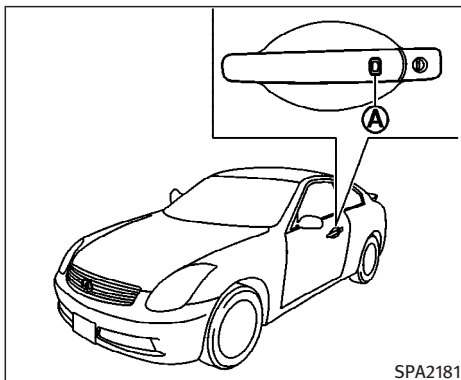

Coupe

SPA2181

When you carry the Intelligent Key with you, you can lock or unlock all doors by pushing the door handle request switch (A) within the range of operation.

Locking doors and fuel-filler door

1. Turn the ignition switch to the LOCK position and remove the ignition key if any metal key is in the ignition switch.*1, *2
2. Close all the doors.*3
3. Push any door handle request switch while carrying the Intelligent Key with you.*4
4. All the doors and fuel-filler door will lock.
5. The hazard indicator flashes twice and outside buzzer sounds twice.

*1: Doors lock with the Intelligent Key while a mechanical key or valet key is in the ignition switch.

*2: Doors lock with the Intelligent Key while the ignition switch is not in the LOCK position.

*3: Doors do not lock by pushing the door handle request switch or the LOCK  button on the Intelligent Key while any door is open. Outside

buzzer sounds to warn you. However, doors lock with the metal key even if any door is open.

*4: Doors do not lock with door handle request switch with the Intelligent Key inside the vehicle and outside buzzer sounds to warn you. However, when an Intelligent Key is inside the vehicle, doors can be locked with another Intelligent Key.

Unlocking doors and fuel-filler door

1. Push the door handle request switch once.

Driver's side:

- The driver door and fuel-filler door unlock.

Front passenger side:

- Only corresponding door unlocks.

2. The hazard indicator flashes once and outside buzzer sounds once if all doors are completely closed with the ignition switch in any position except the ON position.
3. Push the door handle request switch again within 5 seconds.

- All doors and the fuel-filler door unlock.
- The hazard indicator flashes once and outside buzzer sounds once if all doors are completely closed.

All doors will be locked automatically after pushing the door handle request switch unless one of the following operations is performed within 1 minute.

- any door is opened
- the ignition switch is pushed
- the mechanical key or the valet key is inserted into the ignition switch

The interior light, ceiling light (if so equipped) and step light can be turned off without waiting for 30 seconds by turning the ignition switch to the ON position or by locking the doors.

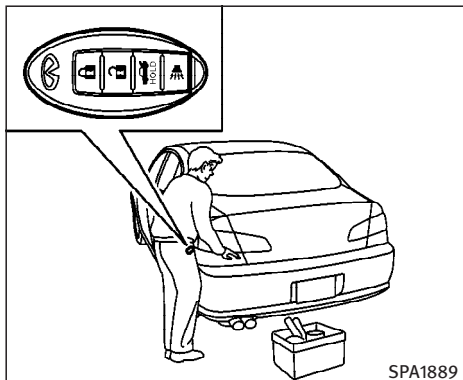

SPA1889

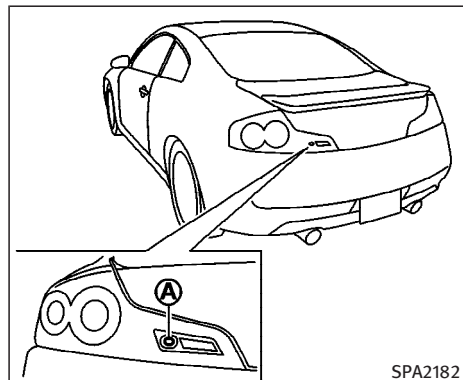

SPA2182

Coupe

Opening trunk lid

1. Push the trunk open request switch **(A)**.
2. The trunk will be unlatched and buzzer sounds four times.
3. Raise the trunk lid to open the trunk.

Lockout protection:

To prevent the Intelligent Key from being accidentally locked in the trunk, lockout protection is equipped with the Intelligent Key system.

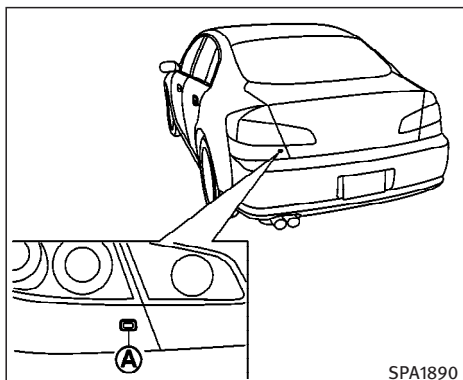



SPA1890

Sedan

When the trunk lid is closed with the Intelligent Key inside the trunk, the outside buzzer will sound and the trunk will open.

OPENING AND CLOSING WINDOWS

- To open the windows, push the UNLOCK  button on the Intelligent Key for **about 3 seconds** or turn the door key cylinder with the metal key to the rear of the vehicle for **about 2 seconds** after the door is unlocked.

To stop opening, release the UNLOCK  button or turn the key to the neutral position.

- To close the windows, turn the door key cylinder to the front of the vehicle for **about 2 seconds** after the door is locked.

To stop closing, turn the key to the neutral position.

The door windows will open or close while turning the metal key. See “Doors” earlier in this section.

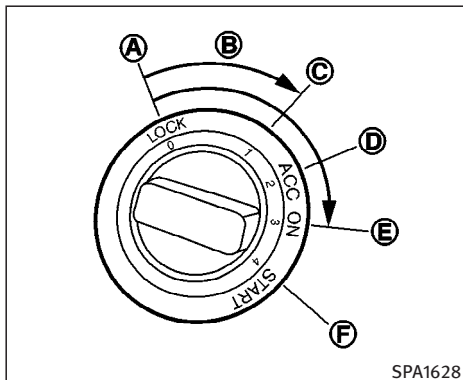

OPERATING THE ENGINE

Ignition switch positions

Push in the ignition switch in the **(B)** range when you turn it.

LOCK (Normal parking position) **(A)**:

The ignition switch can only be locked in the **(A)** position.

The ignition switch will be unlocked when it is pushed in, and turned to the ACC position **(D)** while carrying the Intelligent Key.

ACC (Accessories) **(D)**:

This position activates electrical accessories such as the radio, when the engine is not running.

ON (Normal operating position) **(E)**:

This position turns on the ignition system and electrical accessories.

START **(F)**:

This position starts the engine. As soon as the engine has started, release the switch immediately. It will automatically return to the ON position.

For important safety information, see “Ignition switch” in the “5. Starting and driving” section.

The ignition switch cannot be turned back to the LOCK position unless the shift lever is in P position. (It can be turned to only **(C)**.)



CAUTION

Do not leave the vehicle with the ignition switch in ACC or ON position when the engine is not running for an extended period. This can discharge the battery.

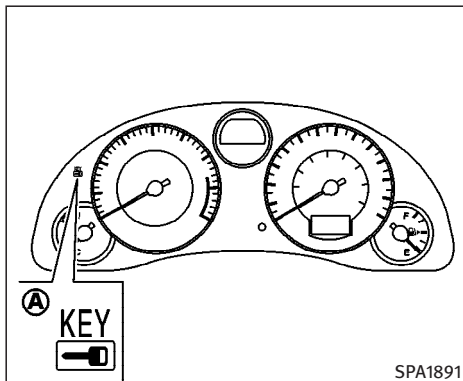

Starting the engine

When driving the vehicle, be sure to carry the Intelligent Key with you.

1. Securely depress the brake pedal.
2. Slowly push the ignition switch in. When the Intelligent Key warning light **A** in the instrument panel comes on in green, the ignition switch can be turned.
3. Turn the ignition switch to the START position and the engine will be started.

4. When the engine starts, release the ignition switch.



WARNING

Do not start the engine from outside the vehicle through the window. Doing so could lead to an accident and injury. Be sure to sit in the driver's seat to use the key.

For important safety information, see “Starting the engine” in the “5. Starting and driving” section.

- When the ignition switch is pushed under the following conditions, the Intelligent Key warning light in the instrument panel comes on in red. It is not possible to turn the ignition switch when:
 - you do not have the Intelligent Key with you
 - the Intelligent Key battery has run down
 - you have a Intelligent Key for another vehicle with you

- Slowly turn the ignition switch after the Intelligent Key warning light comes on in green. If it is turned quickly, it may stick and be difficult to turn.
- The engine may not start if the Intelligent Key is placed:
 - inside the glove box or the door pocket
 - on the instrument panel
 - in the corner of interior compartment.
- If it is difficult to turn the ignition switch, perform the following:
 - Push the ignition switch and turn it to the left and then to the right.
 - Turn the ignition switch while gently turning the steering wheel to the left or right.

Stopping the engine

1. Shift the selector lever to the P position.
2. Turn the ignition switch to the ACC position.



WARNING

When you leave the vehicle, be sure to observe the following:

- Shift the selector lever to P. (In other positions, the ignition switch will not return to LOCK.)
- Securely return the ignition switch to LOCK.
- Set the parking brake. Failure to do so could result in unexpected vehicle movement and could lead to severe injury.

INTELLIGENT KEY OPERATING RANGE

The Intelligent Key functions can be used only when you carry the key with you and operate as specified in the operating range inside or outside the vehicle.

When the Intelligent Key battery runs down or where there are strong radio waves or noise, the operating range may be narrower or the key may be inoperative.

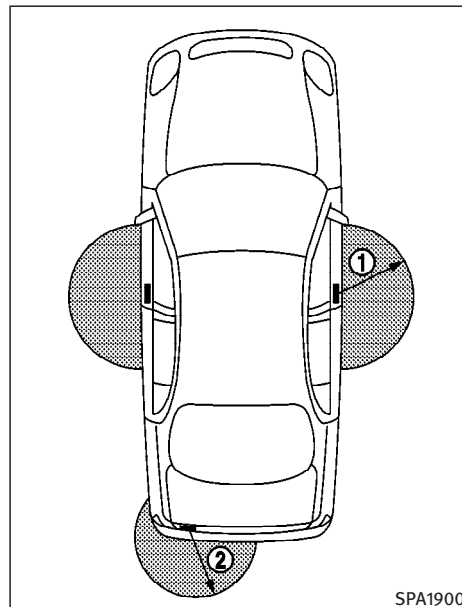

SPA1900

Operating range of the door or trunk lock/unlock function

The outside sensors are in the front outside door handles and the trunk.

The operating range of the door or trunk lock/unlock function by pushing the door handle request switch or trunk open request switch is shown in the illustration.

- ① 31.5 in (80 cm) from the door handle request switch
 - ② 31.5 in (80 cm) from the trunk open request switch
- If you are too close to the outside door handles or rear bumper, the Intelligent Key may not operate.
 - If the Intelligent Key is in the operating range, it is possible for anyone who does not carry the Intelligent Key to lock/unlock the doors by pushing the door handle request switch.

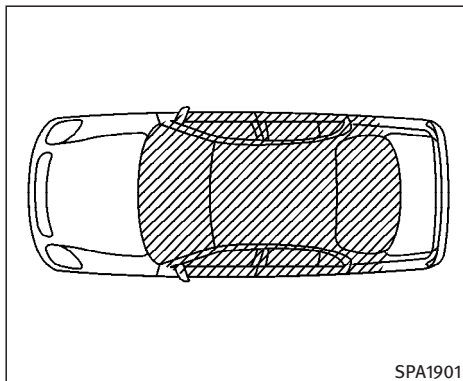

Operating range for engine start function

The operating range for starting the engine is inside the vehicle.

- If the Intelligent Key is on the instrument panel, rear parcel shelf, inside the glove box or door pocket, or the corner of interior compartment, it may not be possible to start the engine.
- If the Intelligent Key is near the door or door glass outside the vehicle, it may be possible to start the engine.

WARNING SIGNALS

To help prevent the vehicle from moving unexpectedly by erroneous operation of the Intelligent Key or to help prevent the vehicle from being stolen, chime or beep sounds inside and outside the vehicle and a warning light comes on in the instrument panel.

When a chime or beep sounds or the warning light comes on, be sure to check the vehicle and Intelligent Key.

Alarm and warning when locking the doors

When the front door warning chime or outside buzzer sounds, check for the following:

- The ignition switch is turned to the LOCK position.
- The Intelligent Key is not left inside the vehicle.
- Doors are closed securely.
- The selector lever is in the P position.

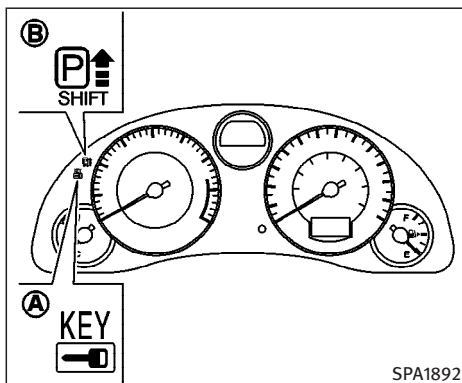

Alarm and warning when the engine stops

When the P position selecting warning light (B) in the instrument panel blinks in red:

- Make sure the selector lever is in the P position.

When the chime sounds intermittently:

- Make sure the selector lever is in the P position and the ignition switch is turned to the LOCK position.

If the chime sounds continuously when the driver's door is opened, check the following:

- The selector lever is in the P position and the ignition switch is turned to the LOCK position.
- The mechanical key or the valet key is not inserted into the ignition switch.
- The inside warning chime may stop when one of the following is performed.
 - Returning the ignition switch to the LOCK position.
 - Removing the mechanical key or the valet key.
 - Closing the doors.

Alarm and warning when the engine starts

When the Intelligent Key warning light (A) is blinking in red and the outside buzzer sounds, make sure the Intelligent Key is inside the vehicle.

Warning for low battery power

- This warning is to let you know that the battery of the Intelligent Key will run down soon. Replace it with a new one.
 - The green blinking Intelligent Key warning light (A) goes out about 30 seconds after the ignition switch is turned to ON.
- We recommend replacing the battery at an INFINITI dealer.

Preventing the Intelligent Key from being left in the vehicle

If you lock all doors using the power door lock switch with the Intelligent Key in the vehicle, all of the doors unlock immediately and the beep sounds to warn you when the door is closed.

TROUBLE-SHOOTING GUIDE

Symptom	Possible Cause	Remedy	
When pushing the door handle request switch	The outside buzzer sounds for approximately 2 seconds.	The doors cannot be locked.	Take out the Intelligent Key from the vehicle and push the door handle request switch.
			Turn the ignition switch to the LOCK position and push the door handle request switch while carrying the Intelligent Key with you.
			Close all the doors securely and push the door handle request switch while carrying the Intelligent Key with you.
When closing the doors	The outside buzzer sounds for approximately 10 seconds.	The ignition switch is not turned to the LOCK position.	Turn the ignition switch to the LOCK position.
	The Intelligent Key warning light in the instrument panel blinks in red and the outside buzzer sounds 3 times.	The Intelligent Key is not in the vehicle.	Be sure to carry the Intelligent Key with you.
	The outside buzzer sounds for approximately 3 seconds and all doors unlock.	The Intelligent Key has been left in the vehicle.	Take out the Intelligent Key from the vehicle and close the door.
When closing the trunk	The outside buzzer sounds and the trunk opens.	The Intelligent Key has been left in the trunk room.	Take out the Intelligent Key from the trunk room and close the trunk.
When opening the driver's door	An inside warning chime sounds continuously.	The ignition switch is not in the LOCK position, or the mechanical key or valet key is inserted into the ignition switch.	Turn the ignition switch to the LOCK position. Remove the mechanical key or valet key from the ignition switch.
When stopping the engine	The P position selecting warning light in the instrument panel blinks in red.	The selector lever is not in the P position.	Make sure that the selector lever is in the P position.
When turning the ignition switch	An inside warning chime sounds continuously.	The ignition switch is not turned to the LOCK position.	Turn the ignition switch to the LOCK position.
When starting the engine	The Intelligent Key warning light in the instrument panel blinks in green.	The battery charge is low.	Replace the battery with a new one. See "KEYFOB BATTERY REPLACEMENT" in the "8. Maintenance and do-it-yourself" section.
When pushing the ignition switch	The Intelligent Key warning light in the instrument panel comes on in red.	The Intelligent Key is not in the vehicle.	If the Intelligent Key warning light comes on in red even while you are carrying the Intelligent Key, the battery is completely discharged. Replace the battery with a new one. See "KEYFOB BATTERY REPLACEMENT" in the "8. Maintenance and do-it-yourself" section.

Troubleshooting examples



When it is difficult to turn the ignition switch

- Push the ignition switch and turn it to the left and then to the right.
- While gently turning the steering wheel to the left or right, turn the ignition switch.

OPERATION WITH INTELLIGENT REMOTE KEYLESS ENTRY SYSTEM

It is possible to lock/unlock all doors, fuel-filler door, activate the panic alarm and open the windows by pushing the buttons on the Intelligent Key from outside the vehicle.

Before locking the doors, make sure the key is not left in the vehicle.

The LOCK  /UNLOCK  button on the Intelligent Key can operate at a distance of approximately 33 ft (10 m) from the vehicle. (The effective distance depends upon the conditions around the vehicle.)

As many as 4 Intelligent Keys can be used with one vehicle. For information concerning the purchase and use of additional Intelligent Key, contact an INFINITI dealer.

3-20 Pre-driving checks and adjustments

The lock and unlock buttons on the Intelligent Key will not operate when:

- the Intelligent Key is too far away from the vehicle
- the Intelligent Key battery runs down



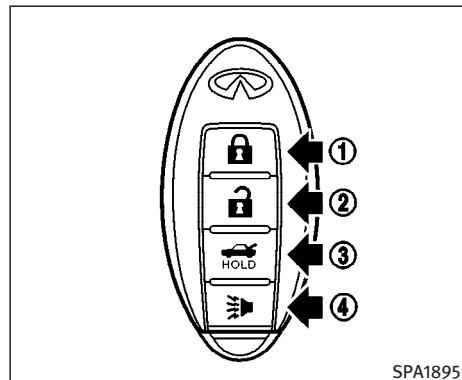

After locking with the Intelligent remote keyless entry function, pull the door handle to make sure the doors are securely locked.

The operating range varies depending on the environment. To securely operate the lock and unlock buttons, approach the vehicle to about 3 ft (1 m) from the door.

The panic alarm will not activate when the mechanical key or the valet key is in the ignition switch.



SPA1895

- ① LOCK button 
- ② UNLOCK button 
- ③ TRUNK button  HOLD
- ④ PANIC button 

How to use remote keyless entry system

Locking doors and fuel-filler door:

1. Remove the mechanical key or the valet key if any key is in the ignition switch.*1
2. Close all the doors.*2

3. Push the LOCK  button on the Intelligent Key.
4. All doors and fuel-filler door will lock.

All of the doors will lock when the LOCK  button on the Intelligent Key is pushed even though the ignition switch is in the ON position.

5. The hazard indicator flashes twice and the horn chirps once.
 - When the LOCK  button is pushed with all doors locked, the hazard indicator flashes twice and the horn chirps once as a reminder that the doors are already locked.
- *1: Doors lock with the Intelligent Key while the mechanical key or the valet key is in the ignition switch or the ignition switch is pushed in.
- *2: Doors do not lock with the Intelligent Key while any door is open.

Unlocking doors and fuel-filler door:

1. Push the UNLOCK  button on the Intelligent Key once.
 - The driver's door and fuel-filler door unlock

- The hazard indicator flashes once if all doors are completely closed with the ignition switch in any position except the ON position.
 - The interior light turns on and the light timer activates for 30 seconds when the switch is in the DOOR position with the ignition switch in any position except the ON position.
2. Push the UNLOCK  button on the Intelligent Key again within 5 seconds.
 - All doors unlock.
 - The hazard indicator flashes once if all doors are completely closed.

All doors will be locked automatically unless one of the following operations is performed within 1 minute of pushing the UNLOCK  button.

- opening any door
- the ignition switch is pushed
- the mechanical key or the valet key is inserted into the ignition switch

The interior light can be turned off without waiting for 30 seconds by turning the ignition switch to the ON position or by locking the doors with the Intelligent Key.

Opening the windows:

See “Opening and closing windows” on the previous page.

Releasing the trunk lid:

1. Push and hold the TRUNK  button on the Intelligent Key **for longer than 0.5 second** when the ignition switch is in any position except the ON position.
2. The trunk lid opens.





The trunk lid cannot be opened by operating the Intelligent Key when the ignition switch is in the ON position.

Using the panic alarm:

If you are near your vehicle and feel threatened, you may activate the alarm to call attention as follows:

1. Push the PANIC  button on the Intelligent Key for **longer than 0.5 second** with the metal key removed from the ignition switch or the ignition switch not pushed in.
2. The theft warning alarm and headlights will stay on for 25 seconds.

3. The panic alarm stops when:

- It has run for 25 seconds, or
- The LOCK  , UNLOCK  , TRUNK  or PANIC  button on the Intelligent Key is pushed for longer than 0.5 second.

Hazard indicator and horn mode



	DOOR LOCK	DOOR UNLOCK
Keyfob or Intelligent Key	HAZARD - twice	No operation
Door handle request switch		

Hazard indicator mode



	DOOR LOCK	DOOR UNLOCK
Keyfob or Intelligent Key	HAZARD - twice HORN-once	HORN - once
Door handle request switch	HAZARD - twice OUTSIDE BUZZER - twice	HORN - once OUTSIDE BUZZER - once

Setting hazard indicator and horn mode:



This vehicle is set in hazard indicator and horn mode when you first receive the vehicle.

In hazard indicator and horn mode, when the LOCK  button is pushed, the hazard indicator flashes twice and the horn chirps once. When the UNLOCK  button is pushed, the hazard indicator flashes once.

If horns are not necessary, the system can be switched to the hazard indicator mode.

In hazard indicator mode, when the LOCK  button is pushed, the hazard indicator flashes twice. When the UNLOCK  button is pushed, neither the hazard indicator nor the horn operates.

Switching procedure:

Push the LOCK  button and UNLOCK  button on the Intelligent Key simultaneously for more than 2 seconds to switch from one mode to the other.

When pushing the buttons to set hazard indicator only mode, the hazard indicator flashes 3 times.

When pushing the buttons to set hazard indicator and horn mode, the hazard indicator flashes once and the horn chirps once.

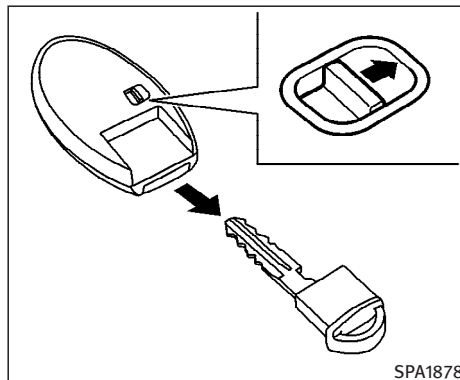
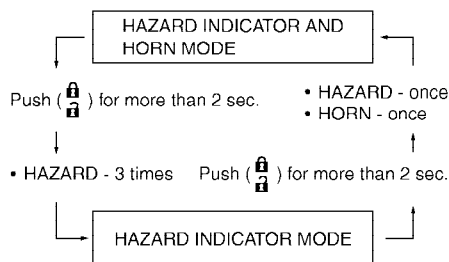

OPERATION WITH THE MECHANICAL KEY AND VALET KEY

If the Intelligent Key cannot be used because its battery is discharged, use the metal key to lock or unlock the doors and use the mechanical key or the valet key, which is registered to the INFINITI Vehicle Immobilizer System components, to start the engine.

Removing the mechanical key

- Release the lock knob at the back of the Intelligent Key and remove the mechanical key.

- To install the mechanical key to the Intelligent Key, securely lock the lock knob and then check that the mechanical key will not move.



CAUTION

Be sure to carry the Intelligent Key with the mechanical key installed in it.

Locking/unlocking the doors with the metal key (mechanical key, valet key and wallet key)

The doors can be locked/unlocked by inserting the metal key into the key cylinder in the driver's door in the same way as the ordinary key.

Starting the engine with the mechanical key

1. Securely depress the brake pedal.
2. Insert the mechanical key or the valet key into the ignition switch.

HOOD

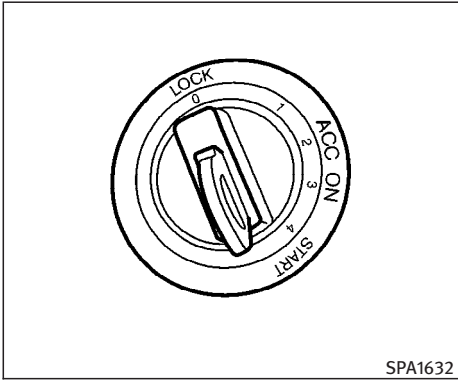

3. Turn the ignition switch to the START position and start the engine.
4. After starting the engine, release the switch.

When the engine is off, the steering wheel lock cannot be unlocked.

For important safety information, see the “5. Starting and driving” section.

Windows open/close with the mechanical key

See “Opening and closing windows” on the previous page.

3-24 Pre-driving checks and adjustments

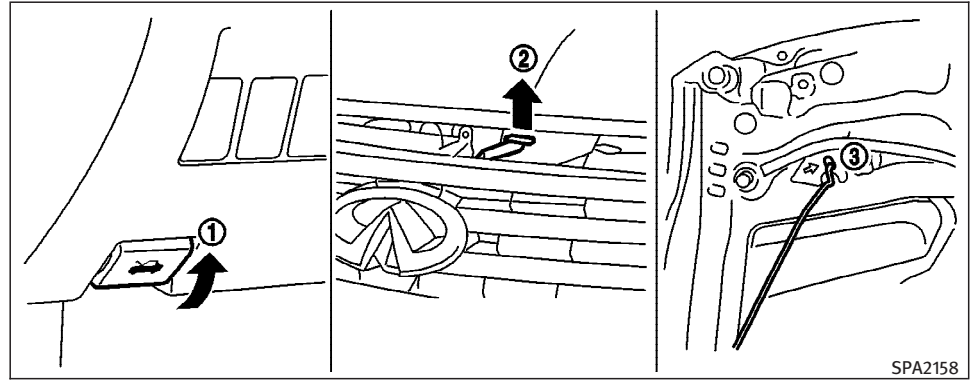

1. Pull the hood lock release handle ① located below the instrument panel; the hood will then spring up slightly.
2. Raise the lever ② at the front of the hood with your fingertips and raise the hood.
3. Insert the assist bar into the slot ③ in the front edge of the hood.
4. When closing the hood, reset the assist bar to its original position, then slowly close the hood and make sure it locks into place.



WARNING

- Make sure the hood is completely closed and latched before driving. Failure to do so could cause the hood to fly open and result in an accident.
- If you see steam or smoke coming from the engine compartment, to avoid injury do not open the hood.

TRUNK LID



WARNING

- Do not drive with the trunk lid open. This could allow dangerous exhaust gases to be drawn into the vehicle. See “Precautions when starting and driving” in the “5. Starting and driving” section for exhaust gas.
- Closely supervise children when they are around cars to prevent them from playing and becoming locked in the trunk where they could be seriously injured. Keep the car locked, with the rear seatback and trunk lid securely latched when not in use, and prevent children’s access to car keys.

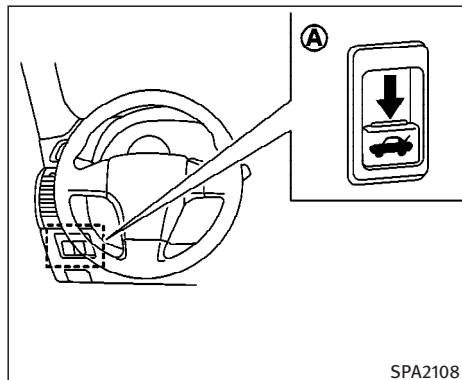

OPENER OPERATION

The trunk lid release switch (A) is located at the bottom of the instrument panel.

To open the trunk lid, slide the trunk lid release switch (A) or push the TRUNK button of the keyfob.

To close, push the trunk lid down securely.

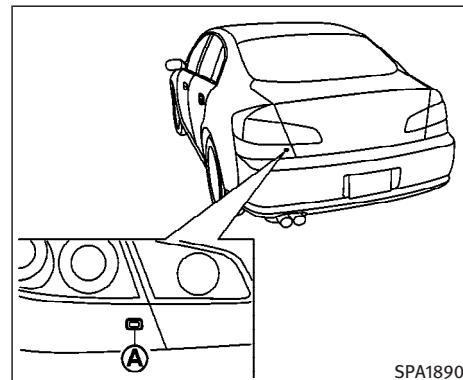

Sedan

Trunk open request switch

Models without Intelligent Key system:

The trunk lid can be opened by pushing the trunk open request switch (A) when the front passenger inside lock knob is in the unlock position.

Models with Intelligent Key system:

The trunk lid can be opened by pushing the trunk open request switch when the Intelligent Key is within the operating range of the trunk lock/unlock function regardless of the inside lock knob posi-

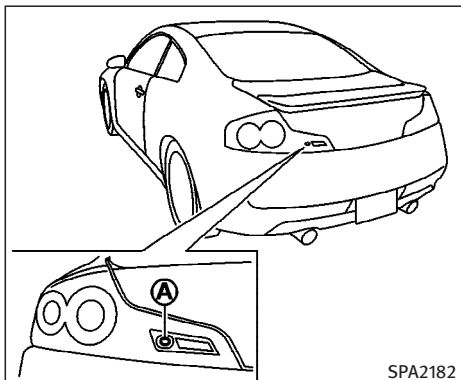

Coupe

tion. See “Intelligent Key system” earlier in this section.

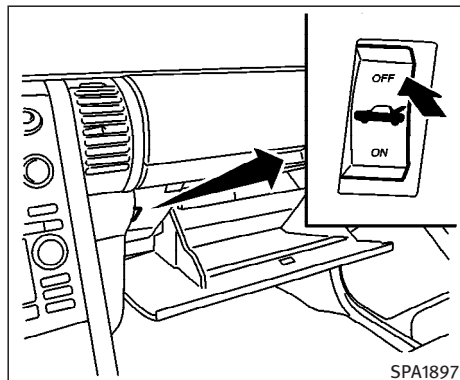

Cancel switch

When the cancel switch located inside the glove box is pushed to the OFF side,

- the trunk lid cannot be opened with the trunk lid release switch.
- the trunk lid cannot be opened by pushing the trunk open request switch.
- for models equipped with the Intelligent Key system, the trunk lockout protection function is not activated.

When the cancel switch located inside the glove box is pushed to the OFF side, the

trunk lid can be opened with the TRUNK button of the keyfob or Intelligent Key.

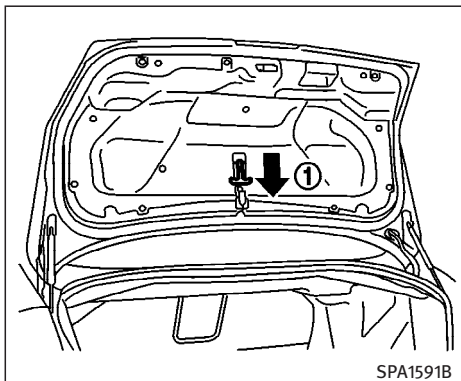

Sedan

INTERIOR TRUNK LID RELEASE

The interior trunk lid release mechanism provides a means of escape in the event of becoming locked inside the trunk.

The handle ① is located on the back side of the trunk lid inside the trunk compartment.

To open the trunk lid from the inside, pull the release handle towards you until the lock releases and push up on the trunk lid. The release lever is made of a material that glows in the dark after a brief exposure to ambient light.

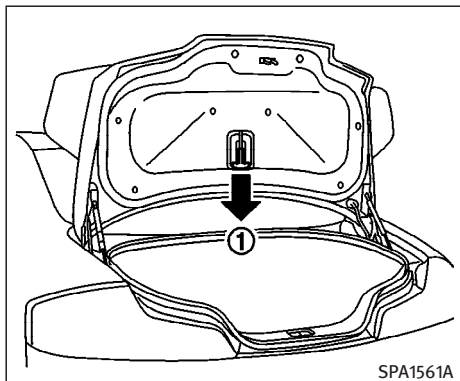

Coupe

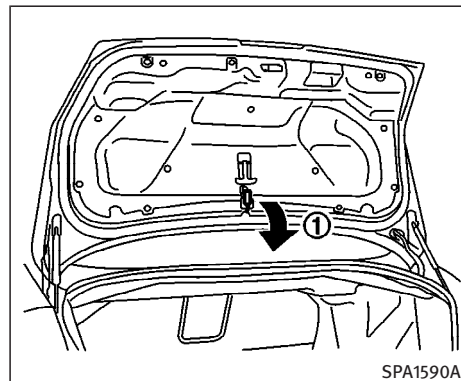

Sedan

SECONDARY TRUNK LID RELEASE

The secondary trunk lid release mechanism allows opening of the trunk lid in the event of the loss of electrical power such as a discharged battery.

The handle ① is located on the back side of the trunk lid inside the trunk compartment.

Sedan

Access the handle through the interior trunk access hole (rear seat armrest).

To open the trunk lid from the rear seat, pull the release handle towards front of vehicle until the lock releases.

Return the handle to the original position by securing the latch. Otherwise, it may cause water to leak into the trunk.

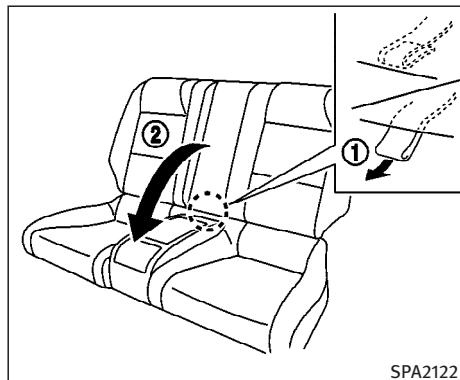

Coupe

Coupe

Access the handle from the rear seat.

Pull the strap ①, located at center bottom of the seatback sideways, and then fold down the seatback ②.

To open the trunk lid from the rear seat, pull the release handle towards front of vehicle until the lock releases.

FUEL-FILLER DOOR

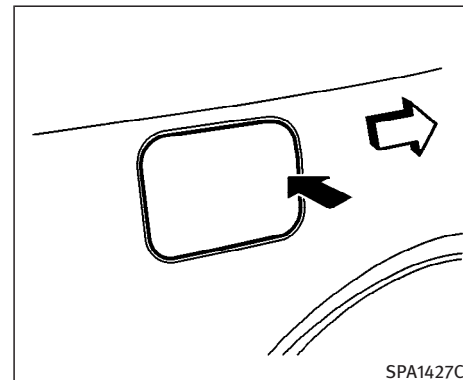

Sedan

OPENING THE FUEL-FILLER DOOR

To open the fuel-filler door, unlock the fuel-filler door lock by using one of the following operations, then push the right-hand side of the lid (Sedan), the left-hand side of the lid (Coupe).

- Push the UNLOCK  button on the keyfob or Intelligent Key once.
- Insert the key into the door lock cylinder and turn the door key cylinder to the rear of the vehicle.
- Push the power door lock switch to the UNLOCK position.

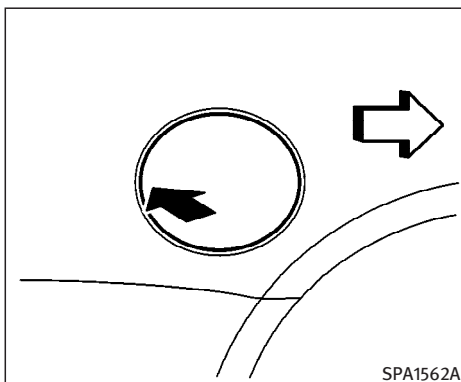

Coupe

To lock, close the fuel-filler door and lock the doors.

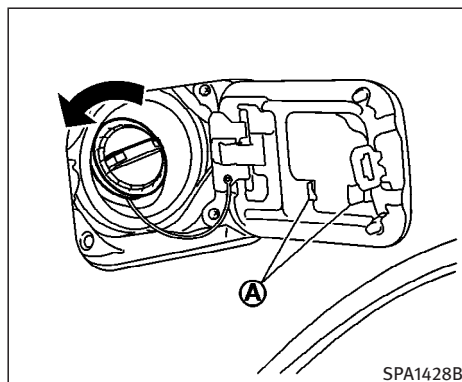

Sedan

FUEL-FILLER CAP

The fuel-filler cap is a ratcheting type. Tighten the cap clockwise until ratcheting clicks are heard.

Put the fuel-filler cap on the cap holder **A** while refueling.



WARNING

- Gasoline is extremely flammable and highly explosive under certain conditions. You could be burned or seriously

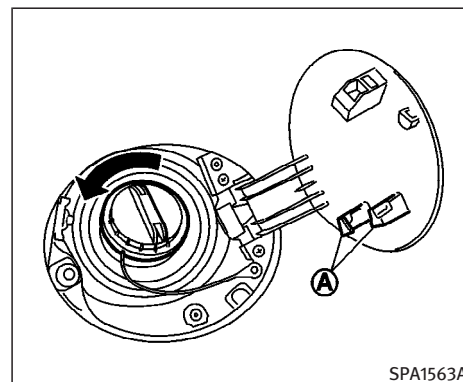

Coupe

injured if it is misused or mishandled. Always stop the engine and do not smoke or allow open flames or sparks near the vehicle when refueling.

- Fuel may be under pressure. Turn the cap a third of a turn, and wait for any “hissing” sound to stop to prevent fuel from spraying out and possibly causing personal injury.
- Do not attempt to top off the fuel tank after the fuel pump nozzle shuts off automatically. Continued refueling may

cause fuel overflow, resulting in fuel-spray and possibly a fire.

- Use only an original equipment type fuel-filler cap as a replacement. It has a built-in safety valve needed for proper operation of the fuel system and emission control system. An incorrect cap can result in a serious malfunction and possible injury. An incorrect cap could also cause the SERVICE ENGINE SOON malfunction indicator lamp to illuminate.
- Do not fill a portable fuel container in the vehicle or trailer. Static electricity can cause an explosion of flammable liquid, vapor or gas in any vehicle or trailer. To reduce the risk of serious injury or death when filling portable fuel containers:
 - Always place the container on the ground when filling.
 - Do not use electronic devices when filling.
 - Keep the pump nozzle in contact with the container while you are filling it.
 - Use only approved portable fuel containers for flammable liquid.
- Never pour fuel into the throttle body to attempt to start your vehicle.



CAUTION

- If fuel is spilled on the vehicle body, flush it away with water to avoid paint damage.
- Tighten until the fuel-filler cap clicks. Failure to tighten the fuel-filler cap properly may cause the SERVICE ENGINE SOON malfunction indicator lamp (MIL) to illuminate. If the SERVICE ENGINE SOON lamp illuminates because the fuel-filler cap is loose or missing, tighten or install the cap and continue to drive the vehicle. The SERVICE ENGINE SOON lamp should turn off after a few driving trips. If the SERVICE ENGINE SOON lamp does not turn off after a few driving trips, have the vehicle inspected by an INFINITI dealer.
- For additional information, see the “Malfunction indicator lamp (MIL)” in the “2. Instruments and controls” section.

STEERING WHEEL

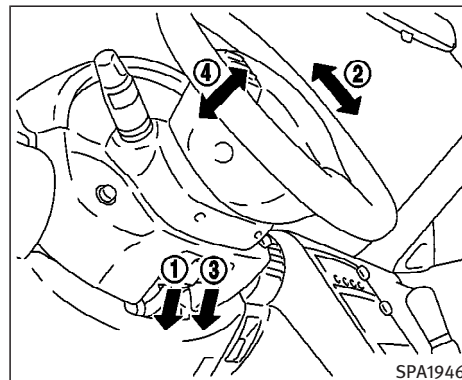

MANUAL OPERATION



WARNING

Do not adjust the steering wheel while driving. You could lose control of your vehicle and cause an accident.

Tilt operation

Pull the lock lever (1) down and adjust the steering wheel up or down (2) to the desired position.

Push the lock lever up securely to lock the steering wheel in place.

Telescopic operation

Pull the lock lever ③ down and adjust the steering wheel forward or backward ④ to the desired position. Push the lock lever up securely to lock the steering wheel in place.

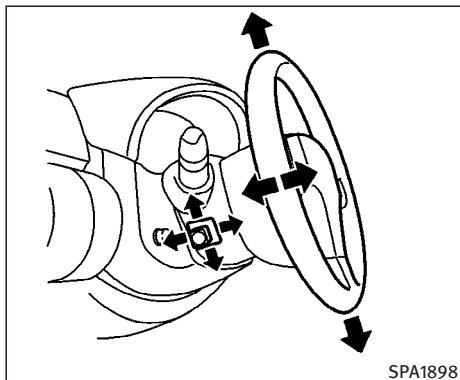

Entry/Exit function operation (if so equipped):

The automatic drive positioner system will make the steering wheel move up automatically when the key is removed from the ignition switch. This lets the driver get into and out of the seat more easily. The steering wheel moves back into position when the key is inserted into the ignition switch. For more information, see “Automatic drive positioner” later in this section.

ELECTRIC OPERATION (if so equipped)



WARNING

Do not adjust the steering wheel while driving. You could lose control of your vehicle and cause an accident.

Tilt or telescopic operation

Move the lever to adjust the steering wheel up or down, forward or rearward to the desired position.

SUN VISORS

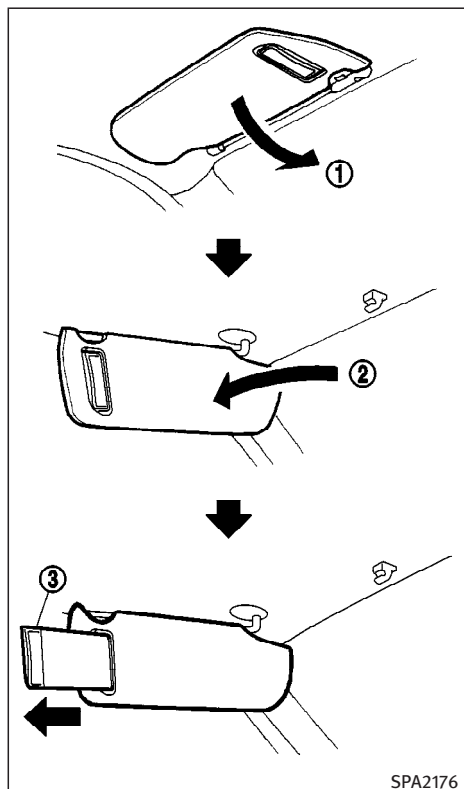

SPA2176



CAUTION

- Do not store the main sun visor before storing the extension sun visor.
- Do not pull the extension sun visor forcibly downward.

1. To block out glare from the front, swing down the main sun visor ①.
2. To block glare from the side, remove the main sun visor from the center mount and swing it to the side ②.
3. Draw out the extension sun visor ③ from the main sun visor to block from further glare.

MIRRORS

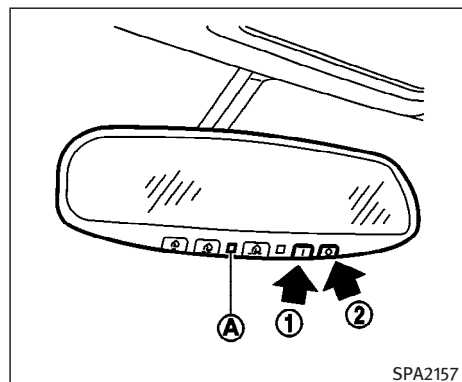

SPA2157

AUTOMATIC ANTI-GLARE INSIDE MIRROR (if so equipped)

The inside mirror is designed so that it automatically changes reflection according to the intensity of the headlight of the following vehicle.

When the inside mirror is in the "I" (AUTO) position ①, excessive glare from the headlights of the vehicle behind you will be reduced. The AUTO indicator light ① (A) (green) will be on. When the switch of the inside mirror is in the "O" (OFF) position ②, the inside mirror will operate normally.

For HomeLink® Universal Transceiver, see the description in the “2. Instruments and controls” section.

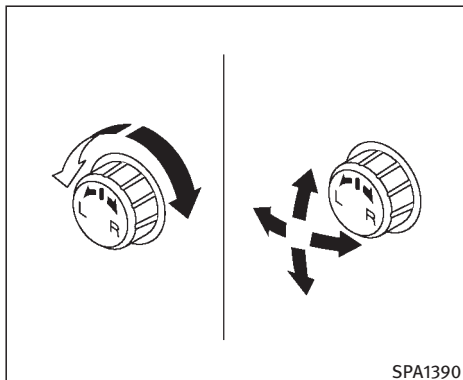

The outside mirror adjustment will operate only when the ignition switch is in the ACC or ON position.

Turn the control knob right or left to select the right or left outside mirror, then adjust by tilting the control knob.

OUTSIDE MIRRORS



WARNING

Objects viewed in the outside mirror on the passenger side are closer than they appear. Be careful when moving to the right. Using only this mirror could cause an accident. Use the inside mirror or glance over your shoulder to properly judge distances to other objects.

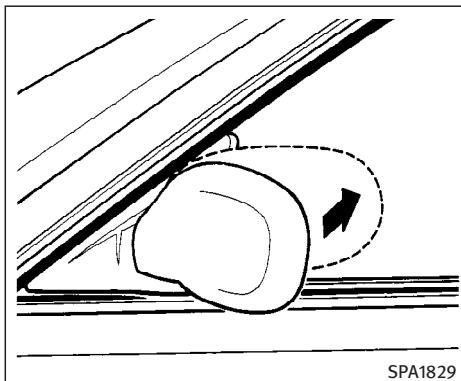

Foldable outside mirrors

Fold the outside mirror by pushing it toward the rear of the vehicle.

AUTOMATIC DRIVE POSITIONER (if so equipped)

AUTOMATIC DRIVE POSITIONER OPERATION

The automatic drive positioner system has two features:

- Entry/exit function (only available on models equipped with automatic transmission)
- Memory storage function

ENTRY/EXIT FUNCTION (if so equipped)

This system is designed so that the driver's seat and steering column will automatically move when the automatic transmission selector lever is in the P (Park) position. This allows the driver to get into and out of the driver's seat more easily. (This feature is not available on models equipped with manual transmission.)

The driver's seat will slide backward and the steering wheel will move up when the driver's door is opened with the key or ignition switch in the LOCK position.

The driver's seat and steering wheel will return to the previous positions:

- When the key is inserted into the ignition switch after closing the driver's

door, or when the driver's door is closed after inserting the key into the ignition switch.

- When the ignition switch is pushed with the driver's door closed.
- When the key or ignition switch is turned to the ON position.

Initializing entry/exit function

The entry/exit function can be activated or cancelled by pushing and holding the SET switch for more than 10 seconds while the ignition switch is in the LOCK position. The indicator light will blink once when the function is cancelled, and the indicator light will blink twice when the function is activated. If the battery cable is disconnected, or if the fuse opens, the entry/exit function will be cancelled. In such a case, after connecting the battery or replacing with a new fuse, open and close the driver's door more than two times with the ignition switch or ignition switch in the LOCK position. The entry/exit function will be activated.

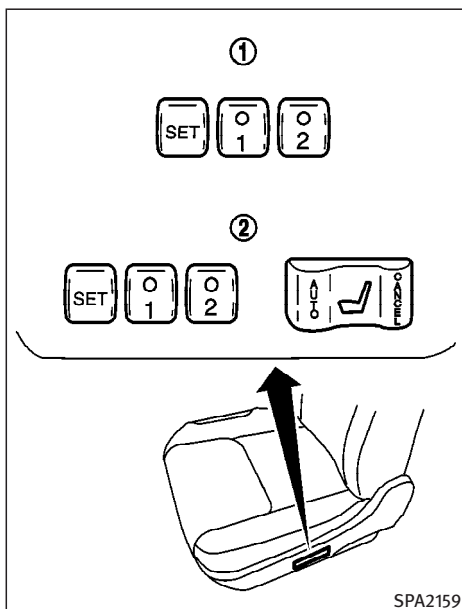

- ① Coupe
- ② Sedan

MEMORY STORAGE FUNCTION

Two positions for the driver's seat and steering column can be stored in the au-

tomatic drive positioner memory. Follow these procedures to use the memory system.

1. For vehicles equipped with automatic transmission, move the selector lever to the P (Park) position.

For vehicles equipped with manual transmission, move the shift lever to the N (Neutral) position and apply the parking brake.

2. Adjust the driver's seat and steering column to the desired positions by manually operating each adjusting switch. For additional information, see "Seats" in the "1. Safety – Seats, seat belts and supplemental restraint system" section and "Steering wheel" earlier in this section.
3. Turn the ignition ON.
4. Push the SET switch and, within 5 seconds, push the memory switch (1 or 2) fully for at least 1 second.

The indicator light for the pushed memory switch will come on and stay on for approximately 5 seconds after pushing the switch. After the indicator light goes off, the selected positions

are stored in the selected memory (1 or 2).

If a new memory is stored in the same memory switch, the previous memory will be deleted.

Linking a keyfob or Intelligent Key to a stored memory position

A keyfob or Intelligent Key can be linked to a stored memory position with the following procedure.

1. Follow the steps for storing a memory position.
2. While the indicator light for the memory switch being set is illuminated for 5 seconds, push the  button on the keyfob or Intelligent Key. The indicator light will blink. After the indicator light goes off, the keyfob or Intelligent Key is linked to that memory setting.

With the key removed from the ignition switch, push the  button on the keyfob or Intelligent Key. The driver's seat and steering wheel will move to the memorized position.

Confirming memory storage

- Turn the ignition ON and push the SET switch. If the main memory has not been stored, the indicator light will come on for approximately 0.5 seconds. When the memory has stored in position, the indicator light will stay on for approximately 5 seconds.
- If the battery cable is disconnected, or if the fuse opens, the memory will be canceled.

Reset the desired position using the previous procedure.

Selecting the memorized position

1. For vehicles equipped with automatic transmission, move the selector lever to the P (Park) position.

For vehicles equipped with manual transmission, move the shift lever in the N (Neutral) position and apply the parking brake.

2. Use one of the following methods to move the driver's seat and the steering wheel.
 - Turn the ignition switch to the "ON" position and push the memory

switch (1 or 2) fully for at least 1 second.

- Within 45 seconds of opening the driver's door, push the memory switch (1 or 2) fully for at least 1 second.

The driver's seat and steering column will move to the memorized position with the indicator light flashing, and then the light will stay on for approximately 5 seconds.

SYSTEM OPERATION

The automatic drive positioner system will not work or will stop operating under the following conditions:

- when the vehicle speed is above 4 MPH (7 km/h).
- when the adjusting switch for the driver's seat and steering column is turned on while the automatic drive positioner is operating.
- when the cancel switch (if so equipped) is pushed to the CANCEL side. (However, it will not be cancelled if the switch is pushed while the seat and steering column are returning to

the previous positions (entry/exit function).)

- when the memory switch 1 or 2 is not pushed and held for at least 1 second.
- when the seat has already been moved to the memorized position.
- when no seat position is stored in the memory switch.
- when the parking brake is not applied. — MT models
- when the speed is above 4 MPH (7 km/h) while the parking brake is applied. — MT models
To restart the drive positioner system, move the parking brake to off and on.
- when the front seat is folded for operating the walk-in mechanism (if so equipped).
- when the engine is started while the automatic drive positioner is operating.
- when the AT selector lever is moved from the P position to any other position. (However, it will not be cancelled if the switch is pushed while the seat and steering column are returning to the previous positions (entry/exit function).)

- when the driver's door remains open for more than 45 seconds and the ignition switch is not in the ON position.

CANCEL SWITCH (if so equipped)

When the CANCEL side of the switch is pushed, the automatic drive positioner system will not function.

When the AUTO side of the switch is pushed, the system will function.

MEMO

4 Display screen, heater, air conditioner and audio systems

Safety note.....	4-2	Audio system	4-14
Control panel buttons — with navigation system	4-2	FM radio reception.....	4-15
Names of the components	4-2	AM radio reception	4-15
How to use joystick and “ENTER” button.....	4-3	Satellite radio reception (if so equipped) ...	4-15
How to use “BACK” button.....	4-3	Audio operation precautions.....	4-16
Setting up the start-up screen.....	4-3	FM-AM-satellite radio with compact disc (CD) changer	4-22
How to use “INFO” button.....	4-3	CD care and cleaning	4-27
How to use “SETTING” button	4-7	Steering wheel switch for audio control	4-28
How to use the ☀/🌙 button	4-9	Antenna	4-29
Ventilators.....	4-9	Car phone or CB radio	4-29
Heater and air conditioner (Automatic).....	4-10	Bluetooth® Hands-Free Phone System with INFINITI Voice Recognition	4-30
Automatic operation	4-11	Using the system	4-32
Manual operation.....	4-12	Control buttons	4-34
Dual button (if so equipped).....	4-12	Getting started	4-34
Ambient temperature	4-13	List of voice commands.....	4-36
Operating tips.....	4-13	Speaker adaptation (SA) mode.....	4-42
In-cabin microfilter.....	4-13	Troubleshooting guide	4-44
Servicing air conditioner	4-14		

SAFETY NOTE



WARNING

- Positioning of the heating or air conditioning controls and display controls should not be done while driving, in order that full attention may be given to driving operation.
- Do not disassemble or modify this system. If you do, it may result in accidents, fire, or electric shock.
- Do not use this system if you notice any abnormality, such as a frozen screen or lack of sound. Continued use of the system may result in accident, fire or electric shock.
- In case you notice any foreign object in the system hardware, spill liquid on it, or notice smoke or smell coming from it, stop using the system immediately and contact an INFINITI dealer. Ignoring such conditions may lead to accidents, fire, or electric shock.

CONTROL PANEL BUTTONS — WITH NAVIGATION SYSTEM

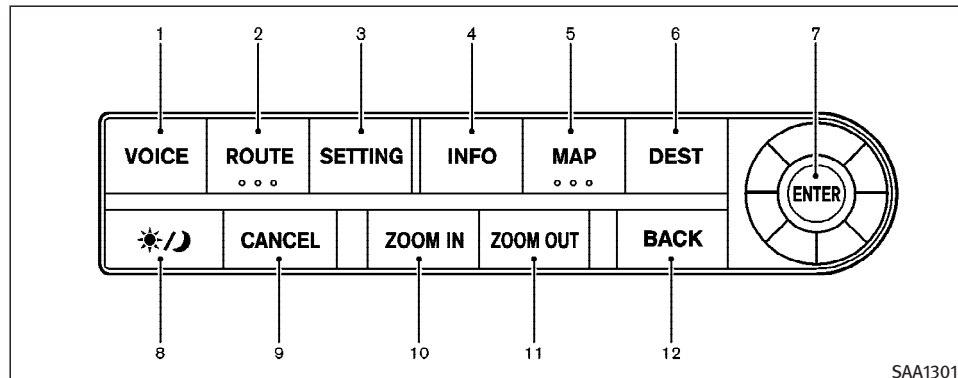

When you use this system, make sure the engine is running.

If you use the system with the engine not running (ignition ON or ACC) for a long time, it will use up all the battery power, and the engine will not start.

Reference symbols:

“ENTER” button — This is a button on the control panel.

“Display” key — This is a select key on the screen. By selecting this key you can proceed to the next function.

NAMES OF THE COMPONENTS

1., 2., 5., 6., 9., 10. and 11.

For Navigation control buttons: refer to the separate Navigation Owner’s Manual.

3. “SETTING” button (P. 4-7)

4. “INFO” button (P. 4-3)

7. Joystick and “ENTER” button (P. 4-3)

8.  brightness control button (P. 4-9)

12. “BACK” button (P. 4-3)

HOW TO USE JOYSTICK AND “ENTER” BUTTON

Choose an item on the display using the joystick and push the “ENTER” button for operation.

HOW TO USE “BACK” BUTTON

This button has two functions.

- Go back to the previous display.

When this button is pushed during setup, setup will be canceled, and the screen will return to the previous screen.

- Finish setup.

When this button is pushed after setup is completed, the settings will be renewed as directed, and the screen will return to the map.

SETTING UP THE START-UP SCREEN

When you turn the ignition switch to the ACC or ON position, the SYSTEM START-UP warning is displayed on the screen. Read the warning and select the “OK” key then push the “ENTER” button.

If you do not push the “ENTER” button, the Navigation system will not proceed to the next step display.

To proceed to the next step, refer to the separate Navigation System Owner’s Manual.

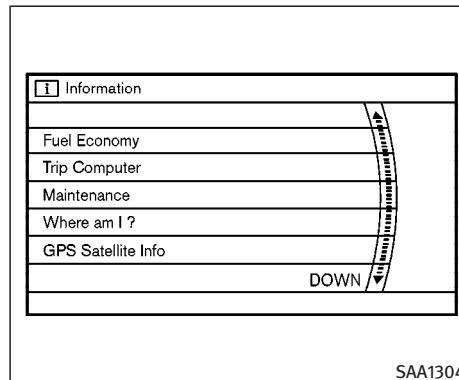

HOW TO USE “INFO” BUTTON

The “**Vehicle Information**” screen will appear when the “INFO” button is pushed.

Choose an item using the joystick and push the “ENTER” button.

After viewing or adjusting the information on the following screens, push the “BACK” button to return to the VEHICLE INFORMATION menu.

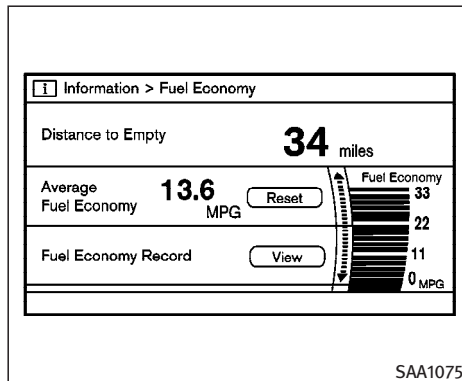
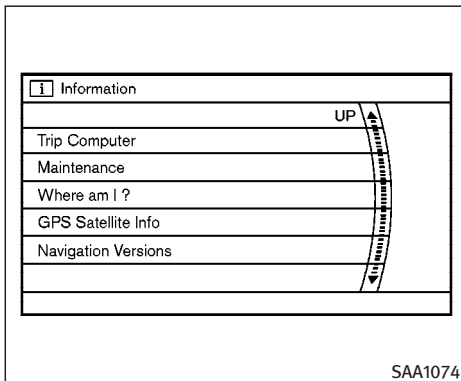

If the **“View”** key is highlighted with the joystick and the **“ENTER”** button is pushed, the average fuel consumption history will be displayed in graph form along with the average for the previous Reset-to-Reset period.

The unit can be converted between **“US”** and **“Metric”**. See **“How to use SETTING button”** later in this section.

Fuel economy information

The distance to empty, average fuel economy and current fuel economy (shown on the right side bar) will be displayed for reference.

To reset the Average Fuel Economy, use the joystick to highlight the **“Reset”** key and push the **“ENTER”** button.

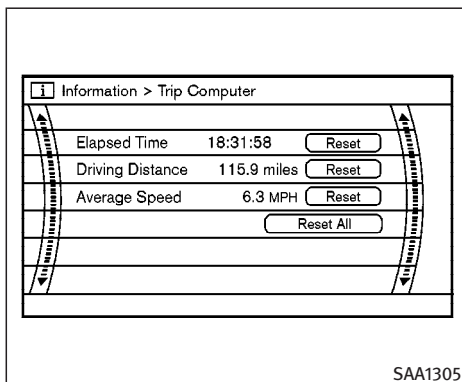

Trip computer information

Elapsed Time, Driving Distance and Average Speed will be displayed.

To reset, use the joystick to highlight the **Reset** key and push the **ENTER** button immediately before driving the vehicle.

The unit can be converted between **US** and **Metric**. See **How to use SETTING button** later in this section.

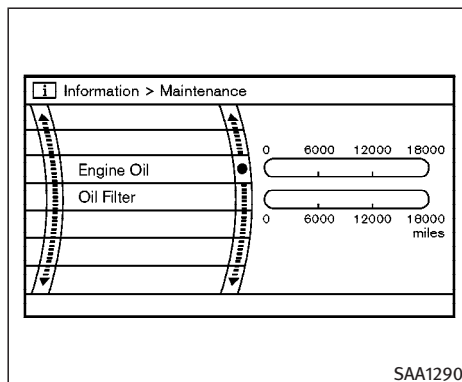

Maintenance information

To set the maintenance interval for the Engine Oil or Oil Filter, choose an item using the joystick and push the **ENTER** button.

You can also set to display a message to remind you that the maintenance needs to be performed.

The following example shows how to set the engine oil change interval. Use the same steps to set the other maintenance information.

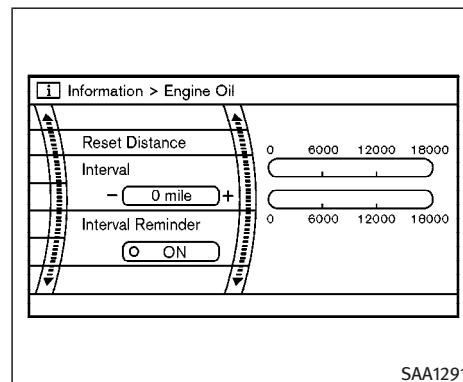

1. Reset the driving distance to the new maintenance schedule.
2. Set the interval (mileage) of the maintenance schedule. To determine the recommended maintenance interval, refer to your **INFINITI Service and Maintenance Guide**.
3. To display the maintenance information automatically when the set trip distance is reached, highlight the **Interval Reminder** key with the joystick and push the **ENTER** button.

4. To return the display to the “**Maintenance**” screen, push the “**BACK**” button.

“Maintenance” display cannot be operated when the vehicle is moving. Stop the vehicle in a safe place to see the information.

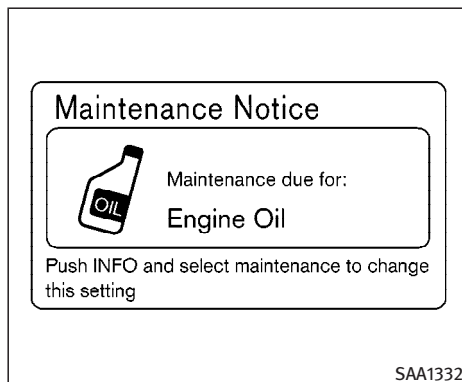

Maintenance notice

The “**Maintenance Notice**” screen (“ENGINE OIL” or “OIL FILTER”) will be automatically displayed as shown when both of the following conditions are met:

- the vehicle is driven the set distance and the ignition switch is turned to the OFF position.
- the ignition switch is turned to the ON position the next time the vehicle will be driven.

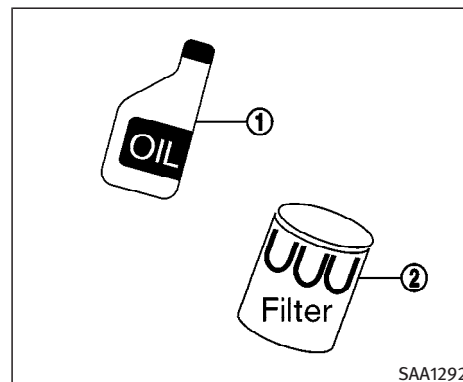

Engine Oil ①/Oil Filter ②

To return to the previous display after the “**Maintenance Notice**” screen is displayed, push the “**BACK**” button.

The “**Maintenance Notice**” screen displays each time the ignition switch is turned ON until one of the following conditions are met:

- “**Reset Display**” is selected.
- “**Interval Reminder**” is set OFF.
- the maintenance interval is set again.

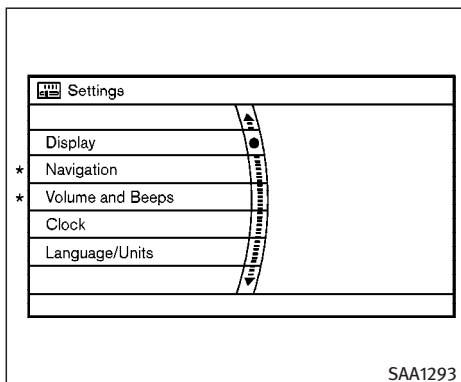

*: Refer to the separate Navigation System Owner's Manual.

HOW TO USE "SETTING" BUTTON

The "Settings" screen will appear when the "SETTING" button is pushed.

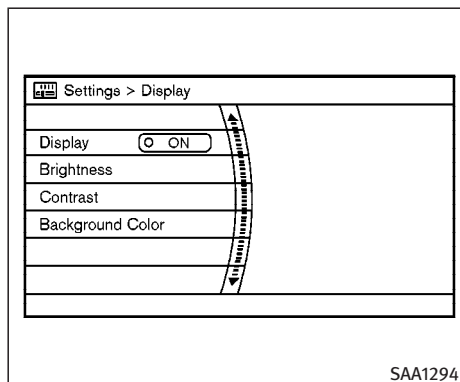

Display settings

The following menu will appear when pushing the "SETTING" button, selecting the "Display" key and pushing the "ENTER" button.

Display:

To turn off the screen, select the "Display" key and push the "ENTER" button to turn off the "ON" indicator. When any mode button is pushed with the screen off, the screen turns on for further operation. The screen will turn off automatically

5 seconds after the operation is finished on the map display.

To turn on the screen, select the "Display" key and turn on the "ON" indicator.

Brightness/Contrast/Background Color:

To adjust the brightness and contrast of the screen, select the "Brightness" or "Contrast" key and push the "ENTER" button. Then you can adjust the brightness to darker or brighter and the contrast to lower or higher using the joystick.

For information on the "Background Color" key, refer to the separate Navigation System Owner's Manual.

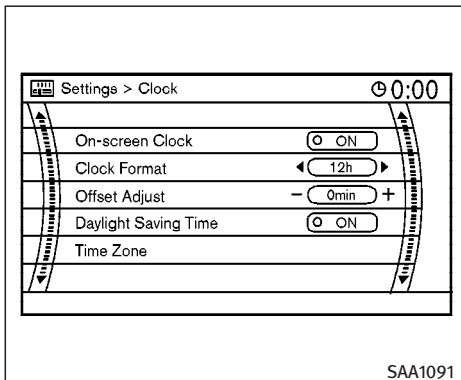

Clock settings

The following display will appear when pushing the “SETTING” button, selecting the “Clock” key and pushing the “ENTER” button.

On-screen Clock:

When this item is turned to ON, a clock is always displayed in the upper right corner of the screen.

This clock will indicate the time almost exactly because it is always adjusted by the GPS system.

Clock Format:

Choose either the 12-hour clock display or the 24-hour clock display.

Offset Adjust:

Adjust the time by increasing or decreasing per minute.

Daylight Saving Time:

Turn this item to ON for daylight saving time application.

Time Zone:

Choose the time zone from the following

- Pacific
- Mountain
- Central
- Eastern
- Atlantic
- Newfoundland

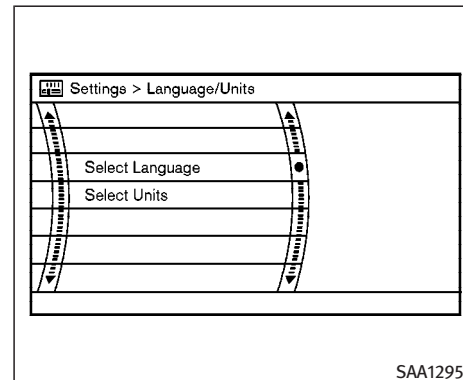

Language/Units settings

The Language/Units setting screen will appear when selecting the “Language/Units” key and pushing the “ENTER” button.

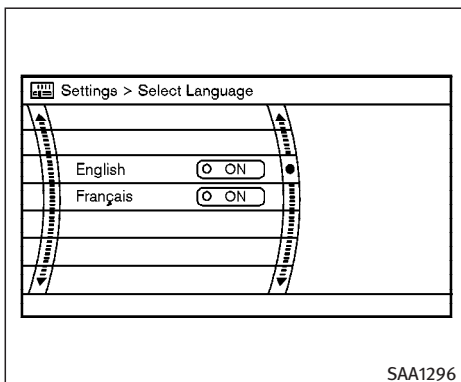

SAA1296

Display of Select Language

Select the “**Select Language**” or “**Select Units**” key and push the “**ENTER**” button.

Language: “English” or “Français”

Unit: “US” — Mile, °F, MPG
 “Metric” — km, °C, L/100 km

Select the “**ON**” key of the desired language or units and push the “**ENTER**” button.

HOW TO USE THE BUTTON

To change the display brightness, push the  button. Pushing the button again will change the display to DAY or NIGHT display. Then, adjust the brightness moving the joystick right or left.

If no operation is done within 10 seconds, or if the “**BACK**” button is pushed, the display will return to the previous display.

VENTILATORS

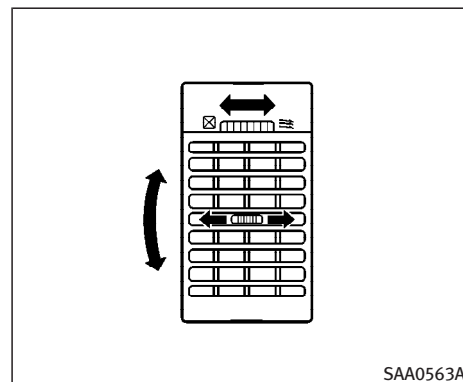



SAA0563A

Front

Adjust the air flow direction of ventilators.





Open or close, and adjust the air flow direction of ventilators.

 : This symbol indicates that the vents are closed when the vent lever is moved left (front) or down (rear).

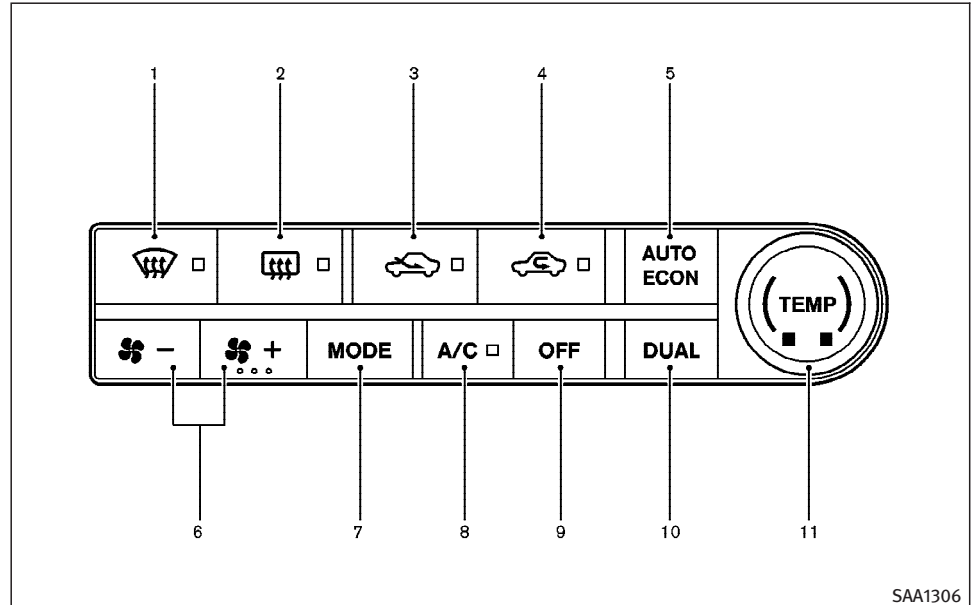
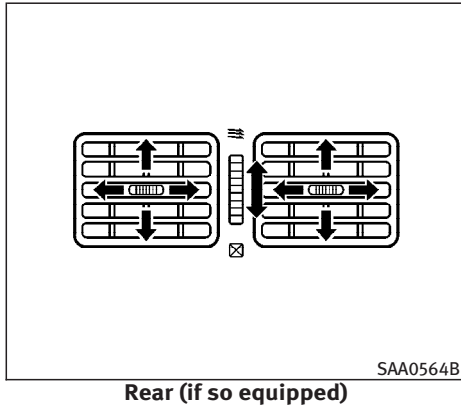
 : This symbol indicates that the vents are open when the vent lever is moved right (front) or up (rear).

HEATER AND AIR CONDITIONER (Automatic)



1. Front window defroster  button
2. Rear window defroster  button (Refer to the “2. Instruments and controls” section.)
3. Outside air circulation  button
4. Air recirculation  button
5. AUTO/ECON button
6. Fan speed control  button
7. MODE (air flow control) button
8. A/C (Air Conditioner) button
9. OFF button
10. DUAL button (if so equipped)
11. TEMP (Temperature control) dial



WARNING

- The air conditioner cooling function operates only when the engine is running.
- On hot, sunny days, temperatures in a closed vehicle could quickly become high enough to cause severe or possibly fatal injuries to people or animals. Do not leave children or adults who would normally require the assistance of others in your vehicle. Unattended pets should also not be left alone.
- Do not use the recirculation mode for long periods as it may cause the interior air to become stale and the windows to fog up.
- Positioning of the heater and/or air conditioner controls should not be done while driving so full attention may be given to vehicle operation.

Start the engine and operate the controls to activate the air conditioner.

AUTOMATIC OPERATION

Cooling and/or dehumidified heating (AUTO)

This mode may be normally used all year round as the system automatically works to keep a constant temperature. Air flow distribution and fan speed are also controlled automatically.

1. Push the AUTO/ECON button on. (AUTO will be displayed.)
 2. If the A/C button indicator is off, push the A/C button to activate air conditioner. The A/C button indicator will come on.
 3. Turn the temperature control dial to set the desired temperature.
- Adjust the temperature to about 75°F (24°C) for normal operation.
 - The temperature of the passenger compartment will be maintained automatically. Air flow distribution and fan speed are also controlled automatically.

Economical operation (ECON)

Economical operation reduces some load to the engine to improve the fuel

economy. It allows higher humidity than normal operation.



Pushing the AUTO/ECON button changes operations as follows while the A/C button indicator is on. AUTO → ECON → AUTO

Heating (A/C off)

The air conditioner does not activate. When you need to heat only, use this mode.

1. Push the AUTO/ECON button. (AUTO will be displayed.)
 2. Push the A/C button to turn off the air conditioner. The A/C button indicator will turn off.
 3. Turn the temperature control dial to set the desired temperature.
- The temperature of the passenger compartment will be maintained automatically. Air flow distribution and fan speed are also controlled automatically.
 - Do not set the temperature lower than the outside air temperature. Otherwise the system may not work properly.
 - Not recommended if windows fog up.



Dehumidified defrosting or defogging

1. Push the front window defroster button  on. (The indicator light on the button will come on.)
 2. Turn the temperature control dial to set the desired temperature.
- To quickly remove ice from the outside of the windows, push the fan speed control button  + and set to the maximum position.
 - As soon as possible after the windshield is clean, push the AUTO/ECON button to return to the auto mode.
 - When the front window defroster button  is pushed, the air conditioner will automatically be turned on at outside temperatures above 23°F (-5°C) to defog the windshield, and the air recirculation mode will automatically be turned off.

Outside air is drawn into the passenger compartment to improve the defogging performance.

MANUAL OPERATION

Fan speed control

Push the fan speed control button  - or  + to manually control the fan speed.

Push the AUTO/ECON button to return to automatic control of the fan speed.

Fresh air

Push the outside air circulation button  to draw outside air into the passenger compartment. The indicator light on the button will come on.





Air recirculation

Push the air recirculation button  to recirculate interior air inside the vehicle. The indicator light on the button will come on.

The air recirculation button will not be activated when the air conditioner is in the defroster mode.

Air flow control (MODE)

Pushing the MODE button selects the air outlet to:

- : Air flows from center and side ventilators.
- : Air flows from center and side ventilators and foot outlets.
- : Air flows mainly from foot outlets.
- : Air flows from defroster and foot outlets.

To turn the system off

Push the OFF button.

DUAL BUTTON (if so equipped)

You can set the temperature of the driver and front passenger sides individually.

Pushing the DUAL button changes the setting position as follows:

Driver/Passenger → Driver → Passenger

If selecting the Driver/Passenger position again after the temperature is individually set, the display will show the temperature set for the driver side.

AMBIENT TEMPERATURE

The outside ambient temperature will be shown on the center display.

The ambient temperature sensor is located in front of the radiator. The sensor may be affected by road or engine heat, wind direction and other driving conditions. The display may differ from the actual outside temperature or the temperature displayed on various signs or billboards.

OPERATING TIPS

When the engine coolant temperature and outside air temperature are low, the air flow from the foot outlets may not operate for a maximum of 150 seconds. However, this is not a malfunction. After the coolant temperature warms up, the air flow from the foot outlets will operate normally.

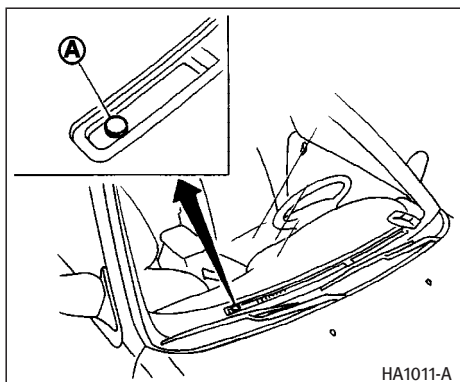

The sensor (A) on the instrument panel helps maintain a constant temperature; do not put anything on or around this sensor.

IN-CABIN MICROFILTER

The air conditioning system is equipped with an in-cabin microfilter which collects dirt, pollen, dust, etc. To make sure air conditioner heats, defogs, and ventilates efficiently, replace the filter in accordance with the maintenance schedule in the INFINITI Service and maintenance guide. To replace the filter, contact an INFINITI dealer.

The filter should be replaced if air flow decreases significantly or if windows fog up easily when operating the heater or air conditioning system.

SERVICING AIR CONDITIONER

The air conditioning system in your INFINITI vehicle is charged with a refrigerant designed with the environment in mind. **This refrigerant will not harm the earth's ozone layer.** However, special charging equipment and lubricant are required when servicing your INFINITI air conditioner. Using improper refrigerants or lubricants will cause severe damage to your air conditioning system. See “Capacities and recommended fuel/lubricants” in the “9. Technical and consumer information” section for air conditioning system refrigerant and lubricant recommendations.

An INFINITI dealer will be able to service your environmentally friendly air conditioning system.



WARNING

The air conditioner system contains refrigerant under high pressure. To avoid personal injury, any air conditioner service should be done only by an experienced technician with proper equipment.

AUDIO SYSTEM

Turn the ignition switch to the ACC or ON position and push the POWER or RADIO button to turn on the radio. If you listen to the radio with the engine not running, the key should be turned to the ACC position.

Radio reception is affected by station signal strength, distance from radio transmitter, buildings, bridges, mountains and other external influences. Intermittent changes in reception quality normally are caused by these external influences.

Using a cellular phone in or near the vehicle may influence radio reception quality.

Radio reception

Your radio system is equipped with state-of-the-art electronic circuits to enhance radio reception. These circuits are designed to extend reception range, and to enhance the quality of that reception.

However there are some general characteristics of FM, AM and satellite radio signals that can affect radio reception quality in a moving vehicle, even when the finest equipment is used. These characteristics are completely normal in a given reception area, and do not indicate any malfunction in your radio system.

Remember that a moving vehicle is not the ideal place to listen to a radio. Because of the movement, reception conditions will constantly change. Buildings, terrain, signal distance and interference from other vehicles can work against ideal reception. Described below are some of the factors that can affect your radio reception.

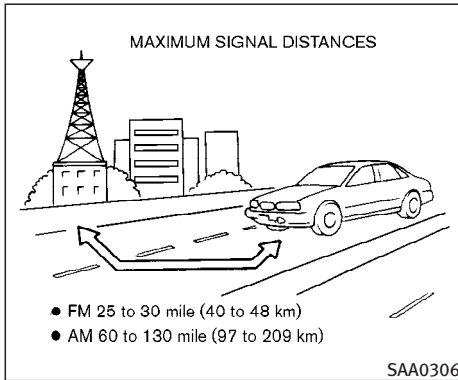

FM RADIO RECEPTION

Range: FM range is normally limited to 25 to 30 miles (40 to 48 km), with monaural (single channel) FM having slightly more range than stereo FM. External influences may sometimes interfere with FM station reception even if the FM station is within 25 miles (40 km). The strength of the FM signal is directly related to the distance between the transmitter and receiver. FM signals follow a line-of-sight path, exhibiting many of the same characteristics as light. For example they will reflect off objects.

Fade and drift: As your vehicle moves away from a station transmitter, the signals will tend to fade and/or drift.

Static and flutter: During signal interference from buildings, large hills or due to antenna position, usually in conjunction with increased distance from the station transmitter, static or flutter can be heard. This can be reduced by adjusting the treble control counterclockwise to reduce treble response.

Multipath reception: Because of the reflective characteristics of FM signals, direct and reflected signals reach the receiver at the same time. The signals may cancel each other, resulting in momentary flutter or loss of sound.

AM RADIO RECEPTION

AM signals, because of their low frequency, can bend around objects and skip along the ground. In addition, the signals can be bounced off the ionosphere and bent back to earth. Because of these characteristics. AM signals are also subject to interference as they travel from transmitter to receiver.

Fading: Occurs while the vehicle is passing through freeway underpasses or

in areas with many tall buildings. It can also occur for several seconds during ionospheric turbulence even in areas where no obstacles exist.

Static: Caused by thunderstorms, electrical power lines, electric signs and even traffic lights.

SATELLITE RADIO RECEPTION (if so equipped)

When the satellite radio is first installed or the battery has been replaced, the satellite radio may not work properly. This is not a malfunction. Wait more than 10 minutes with satellite radio ON for satellite radio to receive all of the necessary data.

No satellite radio reception is available unless optional satellite receiver and antenna are installed and an XM[®] or SIRIUS[™] satellite radio service subscription is active.

Satellite radio is not available in Alaska and Hawaii.

Satellite radio performance may be affected if cargo carried on the roof blocks the satellite radio signal.

If possible, do not put cargo over the satellite antenna.

AUDIO OPERATION PRECAUTIONS

Compact Disc (CD) player

- During cold weather or rainy days, the player may malfunction due to the humidity. If this occurs, remove the CD and dehumidify or ventilate the player completely.
- The player may skip while driving on rough roads.
- The CD player sometimes cannot function when the passenger compartment temperature is extremely high. Decrease the temperature before use.

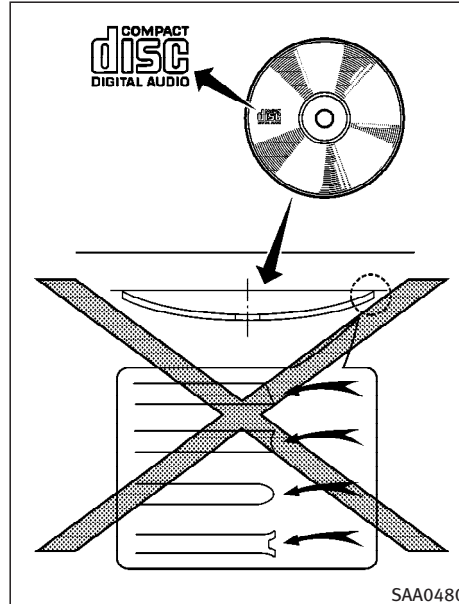

- Only use high quality 4.7 inches (12 cm) round discs that have the “COMPACT disc DIGITAL AUDIO” logo on the disc or packaging.
- Do not expose the CD to direct sunlight.

- CDs that are of poor quality, dirty, scratched, covered with fingerprints, or that have pin holes may not work properly.
- The following CDs may not work properly:
 - Copy control compact discs (CCCD)
 - Recordable compact discs (CD-R)
 - Rewritable compact discs (CD-RW)
- Do not use the following CDs as they may cause the CD player to malfunction.
 - 3.1 in (8 cm) discs
 - CDs that are not round
 - CDs with a paper label
 - CDs that are warped, scratched, or have abnormal edges
- CDs with MP3 or WMA format cannot be written in this audio system.
- If the CD cannot be played, one of the following messages will be displayed.

CHECK DISC:

- Confirm that the CD is inserted correctly (the label side is facing up, etc.).
- Confirm that the CD is not bent or warped and it is free of scratches.

PUSH EJECT:

This is a malfunction due to excessive temperature inside the player. Remove the CD by pushing the EJECT button. After a short time, reinsert the CD. The CD can be played when the temperature of the player returns to normal.

UNPLAYABLE:

The file is unplayable in this audio system (only MP3 or WMA CD).

Compact Disc (CD) with MP3 or WMA

Explanation of terms:

- MP3 — MP3 is short for Moving Pictures Experts Group Audio Layer 3. MP3 is the most well-known compressed digital audio file format. This format allows for near “CD quality” sound, but at a fraction of the size of normal audio files. MP3 conversion of an audio track from CD-ROM can reduce the file size by approximately 10:1 ratio with virtually no perceptible loss in quality. MP3 compression removes the redundant and irrelevant parts of a sound signal that the human ear doesn’t hear.
- WMA — Windows Media Audio (WMA) is a compressed audio format created by Microsoft as an alternative to MP3. The WMA codec offers greater file compression than the MP3 codec, enabling storage of more digital audio tracks in the same amount of space when compared to MP3s at the same level of quality.
- Bit rate — Bit rate denotes the number of bits per second used by a digital music file. The size and quality of a

compressed digital audio file is determined by the bit rate used when encoding the file.

- Sampling frequency — Sampling frequency is the rate at which the samples of a signal are converted from analog to digital (A/D conversion) per second.
 - Multisession — Multisession is one of the methods for writing data to media. Writing data once to the media is called a single session, and writing more than once is called a multisession.
 - ID3/WMA Tag — The ID3 tag is the part of the encoded MP3 or WMA file that contains information about the digital music file such as song title, artist, album title, encoding bit rate, track time duration, etc. ID3 tag information is displayed on the Album/Artist/Track title line on the display.
- * Windows[®] and Windows Media[®] are either registered trademarks or trademarks of Microsoft Corporation in the United States and/or other countries.

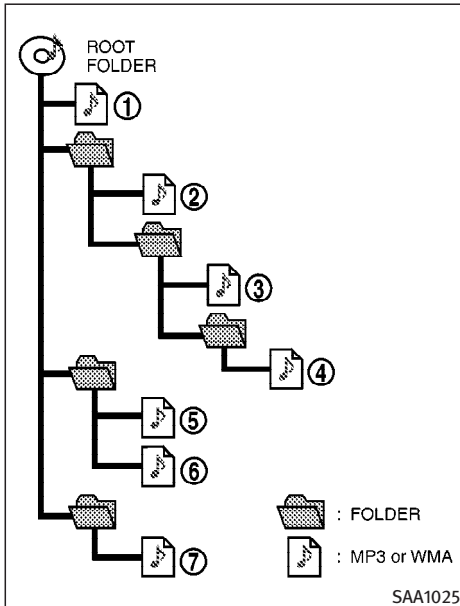

- The names of folders not containing MP3/WMA files are not shown in the display.
- If there is a file in the top level of the disc, “ROOT” is displayed.
- The playback order is the order in which the files were written by the writing software. Therefore, the files might not play in the desired order.

Playback order:

Playback order of the CD with compressed files (MP3/WMA) is as illustrated above.

Specification chart:

Supported media		CD, CD-R, CD-RW	
Supported file systems		ISO9660 LEVEL1, ISO9660 LEVEL2, Romeo, Joliet * ISO9660 Level 3 (packet writing) is not supported.	
Supported versions*	MP3	Version	MPEG1, MPEG2, MPEG2.5
		Sampling frequency	8 kHz - 48 kHz
		Bit rate	8 kbps - 320 kbps, VBR
	WMA	Version	WMA7, WMA8, WMA9
		Sampling frequency	32 kHz - 48 kHz
		Bit rate	48 kbps - 192 kbps, VBR
Tag information		ID3 tag VER1.0, VER1.1, VER2.2, VER2.3 (MP3 only)	
Folder levels		Folder levels: 8, Folders: 255 (including root folder), Files: 512	
Text character number limitation		128 characters	
Displayable character codes		01: ASCII, 02: ISO-8859-1, 03: UNICODE (UTF-16 BOM Big Endian), 04: UNICODE (UTF-16 Non-BOM Big Endian), 05: (UTF-8), 06: UNICODE (Non-UTF-16 BOM Little Endian)	

* Files created with a combination of 48 kHz sampling frequency and 64 kbps bit rate cannot be played.

Troubleshooting guide:

Symptom	Cause and Countermeasure
Cannot play	Check if the disc was inserted correctly.
	Check if the disc is scratched or dirty.
	Check if there is condensation inside the player. If there is, wait until the condensation is gone (about 1 hour) before using the player.
	If there is a temperature increase error, the CD player will play correctly after it returns to the normal temperature.
	If there is a mixture of music CD files (CD-DA data) and MP3/WMA files on a CD, only the music CD files (CD-DA data) will be played.
	Files with extensions other than “.MP3”, “.WMA”, “.mp3” or “.wma” cannot be played. In addition, the character codes and number of characters for folder names and file names should be in compliance with the specifications.
Poor sound quality	Check if the disc is scratched or dirty.
	The bit rate may be too low.
It takes a relatively long time before the music starts playing.	If there are many folder or file levels on the MP3/WMA disc, or if it is a multisession disc, some time may be required before the music starts playing.
Music cuts off or skips	The writing software and hardware combination might not match, or the writing speed, writing depth, writing width, etc., might not match the specifications. Try using the slowest writing speed.
Skipping with high bit rate files	Skipping may occur with large quantities of data, such as for high bit rate data.
Move immediately to the next song when playing.	When a non-MP3/WMA file has been given an extension of “.MP3”, “.WMA”, “.mp3” or “.wma”, or when play is prohibited by copyright protection, there will be approximately 5 seconds of no sound and then the player will skip to the next song.
The songs do not play back in the desired order.	The playback order is the order in which the files were written by the writing software. Therefore, the files might not play in the desired order.

4-20 Display screen, heater, air conditioner and audio systems

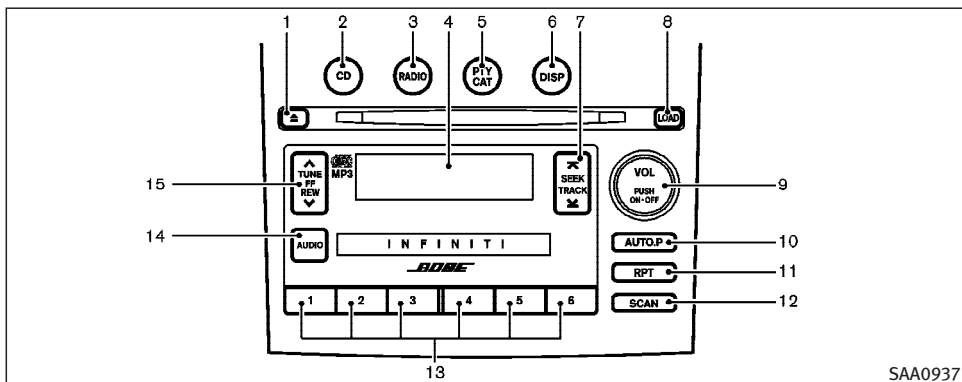

Type A

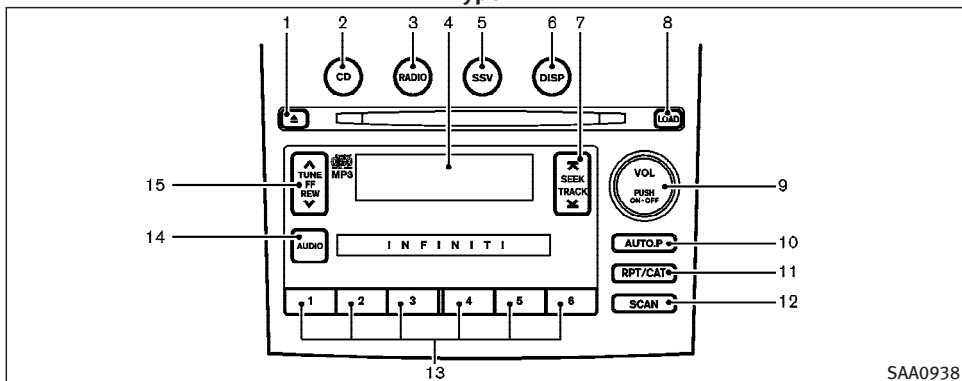

Type B

1. CD EJECT button
2. CD play button
3. RADIO (FM/AM/SAT*) band select button
4. Audio display
5. PTY/CAT (Type A), SSV (Type B) button
6. DISP (Display) CHANGE button
7. SEEK, APS REW/APS FF, TRACK CHANGE button
8. CD LOAD button
9. POWER ON-OFF button, Volume control knob
10. AUTO-P (Automatic preset) button
11. RPT (repeat) play (Type A), RPT (repeat) play/CAT button (Type B)
12. SCAN tuning button
13. Station preset (FM/AM/SAT)/CD insert or CD play select button
14. AUDIO (BASS, TREBLE, FADER, BALANCE, SSV (Type A only)) button
15. RADIO TUNE/FF-REW/AUDIO (BASS, TREBLE, FADER, BALANCE, SSV (Type A only)) ADJUSTING button

* No satellite radio reception is available unless optional satellite receiver and antenna are installed and an XM® or SIRIUS™ satellite radio service subscription is active.

It may take some time to receive the activation signal after subscribing to the XM[®] or SIRIUS[™] satellite radio provider. After receiving the activation signal, an available channel list will be automatically updated in the radio. For XM[®], turn the ignition switch from the LOCK to ACC position to update the channel list.

Satellite radio is not available in Alaska and Hawaii.

FM-AM-SATELLITE RADIO WITH COMPACT DISC (CD) CHANGER

Audio main operation

Head unit:

The radio has an FM diversity reception system, which employs two antennas printed on the rear window. This system automatically switches to the antenna which is receiving less interference.

The auto loudness circuit enhances the low frequency range automatically in both radio reception and CD playback.

POWER on/off:

Turn the ignition switch to the ACC or ON position, and then push the POWER on/off button while the system is off to

call up the mode (radio, tape or CD) which was playing immediately before the system was turned off. When no CD or tape is loaded, the radio will come on. While the system is on, pushing the POWER on/off button turns the system off.

Volume control:

Turn the volume control knob to adjust the volume.

This vehicle has **Speed Sensitive control Volume (SSV) for audio**. The audio volume changes as the driving speed changes.

AUDIO button (BASS, TREBLE, FADER, BALANCE, SSV (Type A only)):

Push the AUDIO button to change the selecting mode as follows.

BASS → TREBLE → FADER → BALANCE → SSV (Type A only) → (Normal) → BASS

To adjust Bass, Treble, Fader and Balance, push the AUDIO button until the desired mode BASS, TREBLE, FADER or BALANCE appears in the display. Push the TUNE

(∇ or \blacktriangle) button to adjust Bass and Treble to the desired level. Use the ∇ or \blacktriangle button also to adjust Fader

or Balance modes. Fader adjusts the sound level between the front and rear speakers and Balance adjusts the sound between the right and left speakers.

To change the SSV mode to OFF, LOW, MID or HIGH, push the ∇ or \blacktriangle (TUNE) button (Type A) or push the SSV button (Type B).

After 10 seconds, the radio, or CD display reappears. Once the sound quality is set to the desired level, push the AUDIO button repeatedly until the radio, or CD display appears.

DISP DISPLAY CHANGE:

This button will work during FM radio, satellite radio (if so equipped) and CD operation. Find the detailed function in the description of each item.

FM-AM-SAT radio operation

RADIO RADIO (FM/AM/SAT) band select:

Pushing the **RADIO** band select button will change the band as follows:

(Without satellite radio)

AM → FM1 → FM2 → AM

(With satellite radio)

AM → FM1 → FM2 → SAT1 → SAT2 → AM

No satellite radio reception is available unless optional satellite receiver and antenna are installed and an XM[®] or SIRI-US[™] satellite radio service subscription is active.

Satellite radio is not available in Alaska and Hawaii.

When the RADIO band select button is pushed while the ignition switch is in the ACC or ON position, the radio will come on at the station last played.

The last station/channel played will also come on when the ON-OFF/VOL control knob is pushed to ON.

If another audio source is playing when the RADIO button is turned to ON, the other audio source will automatically be turned off and the last radio station played will come on.

The FM stereo indicator ST will glow during FM stereo reception. When the stereo broadcast signal is weak, the radio will automatically change from stereo to monaural reception.



TUNE (Tuning):



WARNING



The radio should not be tuned while driving so full attention may be given to vehicle operation.

Push these buttons for manual tuning. To move quickly through the channels, push and hold either of the TUNE buttons down for more than 0.5 second.





SEEK tuning:

For AM and FM radio:

Push the SEEK button  or , to tune from high to low or low to high frequencies and stops at the next broadcasting station.

For satellite radio:

Push the SEEK button  or  to seek channels of the next or previous category.

SCAN

SCAN tuning:

Push the SCAN tuning button to tune from low to high frequencies and stops at each broadcasting station for 5 seconds. Pushing the button again during this 5 seconds period will stop SCAN tuning and the radio will remain tuned to that station.

If the SCAN tuning button is not pushed within 5 seconds, SCAN tuning moves to the next station.

DISP

DISPLAY:

- By pushing the DISP button for more than 1.5 seconds while receiving FM radio waves, “PS NAME” switches between ON and OFF (Type A only).
- Pushing the DISP button will display additional information about the satellite radio broadcast (for example: Artist name, Title). Keep pushing the DISP button, and it will change the information of the satellite radio broadcast to be displayed as follows:
CH Number → CH Name → Artist Name → Song Title → CH Number

Station memory operations:

Twelve stations/channels can be set for the FM band (six for FM1, six for FM2), twelve for satellite radio (six for SAT1, six for SAT2) and six stations can be set for the AM band.

1. Tune to the desired station using the SEEK, SCAN or TUNE button.
2. Select the desired station/channel and keep pushing any of the desired station preset buttons (1 to 6) until a beep sound is heard. (The radio mutes when the select button is pushed.)
3. The channel indicator will then come on and the sound will resume. Memorizing is now complete.
4. Other buttons can be set in the same manner.

If the battery cable is disconnected, or if the fuse blows, the preset station memory will be erased. In that case, reset the desired stations.

AUTO.P Automatic preset:

To select the preset FM, AM, SAT or PTY station/channel, push the AUTO.P button for less than 1.5 seconds.

To preset the FM, AM, SAT or PTY station/channel, push the AUTO.P button for more than 1.5 seconds.

PTY CAT Program type/category (Type A)

RPT/CAT Repeat/category (Type B):

When the PTY button is pushed for more than 1.5 seconds during FM mode, the PTY name of the current tuned station is displayed (Type A only). During this time if the PTY data code is zero, or the data is unreadable; the display will show NONE.

When the PTY (CAT) — type A, or RPT (CAT) — Type B, button is pushed for more than 1.5 seconds during the satellite radio mode, the category name of the current channel is displayed.

1. PTY (CAT) selection mode

PTY (CAT) name selection can be done by the up/down TUNE button \wedge or \vee in the PTY (CAT) selection mode.

It is possible to shift the PTY (CAT) name by one step, with one push of the up/down tuning button \wedge or \vee .

PTY name selection can also be achieved by pushing the preset buttons.

Initial PTY names are stored in the station

preset buttons; but these can be changed by pushing the station preset buttons for more than 1.5 seconds when the desired PTY name is in the display.

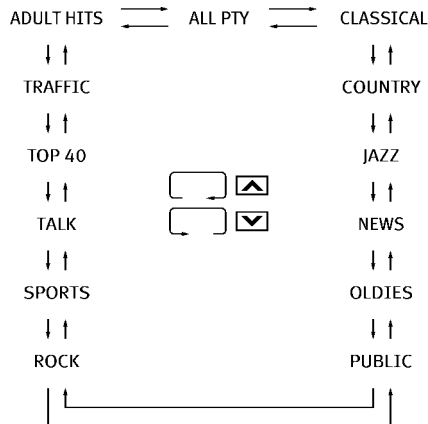

2. PTY SEEK tuning mode

After selecting a PTY name, push the SEEK button \vee or \wedge within 10 seconds. Tuning to the PTY station will start. If you do not push the SEEK button within the 10 second period, the PTY mode will be canceled.

3. PTY SCAN tuning mode

Push the SCAN tuning button to tune the PTY name station, and stop at each broadcasting station for 5 seconds. Pushing the button again during this 5 second period will stop SCAN tuning and the radio will remain tuned to that station. If the SCAN tuning button is not pushed within 5 seconds, SCAN tuning moves to the next station.

Compact disc (CD) changer operation

Turn the ignition switch to the ACC or ON position, push the LOAD button and insert the compact disc into the slot with the label side facing up. The CD will be guided automatically into the slot and start playing.

After loading the disc, the number of tracks on the disc and the play time will appear on the display.

If the radio is already operating, it will automatically turn off and the CD will play.



CAUTION

- Do not force the compact disc into the slot. This could damage the player.
- Do not use 3.1 in (8 cm) discs.

If the system has been turned off while the CD was playing, pushing the ON-OFF/VOL control button will start the compact disc.

LOAD CD LOAD:

To insert a CD in the CD changer, push the LOAD button for less than 1.5 seconds. Select the loading slot by pushing the CD insert select button (1 to 6), then insert the CD.

To insert 6 CDs to the CD changer in succession, push the LOAD button for more than 1.5 seconds.

The inserted slot numbers will illuminate on the display.

CD PLAY:

When the CD button is pushed with the system off and the compact disc loaded, the system will turn on and the compact disc will start to play.

When the CD button is pushed with the CD loaded with the radio playing, the radio will automatically be turned off and the compact disc will start to play.

DISP DISPLAY:

When the display button is pushed for more than 1.5 seconds while the CD is being played, the music information displayed can be changed in the following order.

CD:

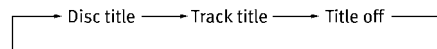

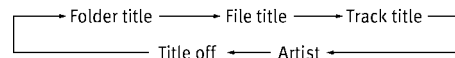

CD with MP3 or WMA:



FF (Fast Forward), REW (Rewind):



CD:

When the  (fast forward) or  (rewind) button is pushed while the compact disc is being played, the CD will play while fast forwarding or rewinding. When

the button is released, the CD will return to normal play speed.



CD with MP3 or WMA:

When the  or  button is pushed for less than 1.5 seconds while the CD is being played, the folders in the CD will be changed.

When the  or  button is pushed for more than 1.5 seconds while the CD is being played, the CD will play while fast forwarding or rewinding. When the button is released, the CD will return to the normal play speed.



APS (Automatic Program Search) FF, APS REW:

When the  (APS FF) button is pushed while the CD is being played, the program after the present one will start to play from its beginning. Push several times to skip through programs. The CD will advance the number of times the button is pushed. (When the last program on the CD is skipped through, the first program will be played.) When the  (APS REW) button is pushed, the program being played returns to its beginning. Push several times to skip back through programs. The CD will go back the number of times the button is pushed.

CD PLAY select button:

To change CD, push the CD play select button (1 to 6).

SCAN tuning:

When the SCAN tuning button is pushed for less than 1.5 seconds while the CD is being played, the beginning of all the CD programs in each track will be played for 10 seconds in sequence.

When the SCAN tuning button is pushed for more than 1.5 seconds while the CD is being played, the first program in all the CDs will be played for 10 seconds.

Pushing the button again during this 10 second period will stop SCAN tuning.

If the SCAN tuning button is not pushed within 10 seconds, SCAN tuning moves to the next disc program.

REPEAT (RPT):

When the RPT button is pushed while the CD is played, the play pattern can be changed as follows:

CD:

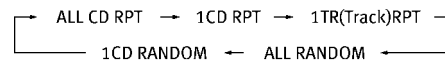

CD with MP3 or WMA:

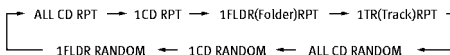

CD EJECT:

When the CD EJECT button is pushed with the CD loaded, the CD will be ejected.

To eject the discs selected by the CD select button, push the EJECT button for less than 1.5 seconds.

To eject all the discs, push the EJECT button for more than 1.5 seconds.

When this button is pushed while the CD is being played, CD will come out and the system will turn off.

If the CD comes out and is not removed, it will be pulled back into the slot to protect it.

CD IN indicator:

CD IN indicator appears on the display when the CD is loaded with the system on.

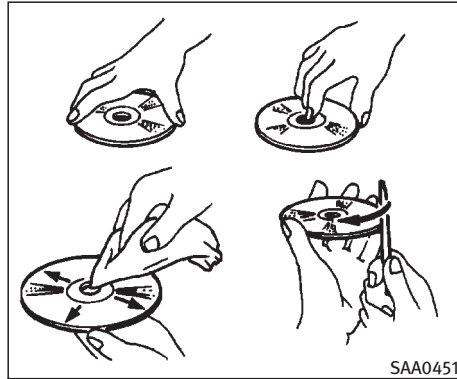

- A new disc may be rough on its inner and outer edges. Remove the rough edges using the side of a pen or pencil as illustrated.

CD CARE AND CLEANING

- Handle a CD by its edges. Never touch the surface of the disc. Do not bend the disc.
- Always place the discs in the storage case when they are not being used.
- To clean a disc, wipe the surface from the center to the outer edge using a clean, soft cloth. Do not wipe the disc using a circular motion.
Do not use a conventional record cleaner or alcohol intended for industrial use.

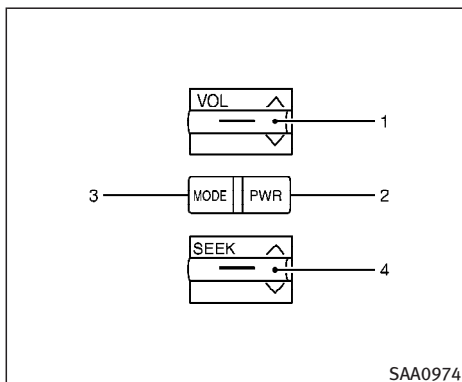

SAA0974

Type A

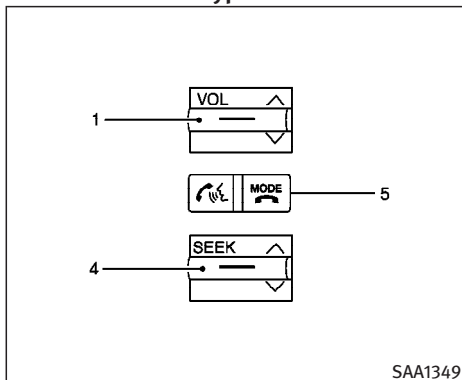

SAA1349

Type B

1. VOLUME control switch
2. POWER on/off switch
3. MODE select switch
4. Tuning switch
5. POWER on/MODE select switch

STEERING WHEEL SWITCH FOR AUDIO CONTROL

The audio system can be operated using the controls on the steering wheel.

POWER on/off switch

With the ignition switch turned to the ACC or ON position, push the POWER switch to turn the audio system on or off.

MODE select switch

Push the MODE select switch to change the mode in the sequence of AM, FM1, FM2, SAT1 (if so equipped), SAT2 (if so equipped) and CD.

Pushing this switch also turns the audio system on when it is off.

POWER on/MODE select switch (if so equipped)

With the ignition switch turned to the ACC or ON position, push the POWER on/MODE select switch to turn the audio

system on. Push the switch to change the mode in the sequence of AM, FM1, FM2, SAT1 (if so equipped), SAT2 (if so equipped) and CD.

VOLUME control switch

Push up/down the VOLUME control switch to increase or decrease the volume.



Tuning switch

Memory change (radio):

Push up/down the tuning switch or for less than 1.5 seconds to change the radio frequency.

SEEK tuning (radio):



Push up/down the tuning switch or for more than 1.5 seconds to seek the next or previous radio station.



APS (Automatic Program Search) FF, APS REW (CD):

Push up/down the tuning switch or for less than 1.5 seconds to return to the beginning of the present program or skip to the next program. Push several times to skip back or skip through programs.



This system searches for the blank intervals between selections. If there is a blank interval within one program or there is no interval between programs, the system may not stop in the desired or expected location.

FOLDER change (CD with MP3/WMA):

Push up/down the tuning switch  or  for more than 1.5 seconds to change the folders (if it has folders).

Push up/down the tuning switch  or  for less than 1.5 seconds to return to the beginning of the present program or skip to the next program.

DISC change (CD without MP3/WMA):

Push up/down the tuning switch  or  for more than 1.5 seconds to change the playing disc up or down.

ANTENNA

Window antenna

The antenna pattern is printed inside the rear window.



CAUTION

- Do not place metalized film near the rear window glass or attach any metal parts to it. This may cause poor reception or noise.
- When cleaning the inside of the rear window, be careful not to scratch or damage the rear window antenna. Lightly wipe along the antenna with a dampened soft cloth.

CAR PHONE OR CB RADIO

When installing a CB, ham radio or car phone in your INFINITI, be sure to observe the following cautions, otherwise the new equipment may adversely affect the Engine control system and other electronic parts.



WARNING

- A cellular telephone should not be used while driving so full attention may be given to vehicle operation. Some jurisdictions prohibit the use of cellular telephones while driving.
- If you must make a call while your vehicle is in motion, the hands free cellular phone operational mode (if so equipped) is highly recommended. Exercise extreme caution at all times so full attention may be given to vehicle operation.
- If a conversation in a moving vehicle requires you to take notes, pull off the road to a safe location and stop your vehicle before doing so.

BLUETOOTH® HANDS-FREE PHONE SYSTEM WITH INFINITI VOICE RECOGNITION



CAUTION

- Keep the antenna as far away as possible from the electronic control modules.
- Keep the antenna wire more than 8 in (20 cm) away from the electronic control system harness. Do not route the antenna wire next to any harness.
- Adjust the antenna standing-wave ratio as recommended by the manufacturer.
- Connect the ground wire from the CB radio chassis to the body.
- For details, consult an INFINITI dealer.



WARNING

- Use a phone after stopping your vehicle in a safe location. If you have to use a phone while driving, exercise extreme caution at all times so full attention may be given to vehicle operation.
- If a conversation in a moving vehicle requires you to take notes, pull off the road to a safe location and stop your vehicle before doing so.



CAUTION

To avoid draining the vehicle battery, use a phone after starting the engine.

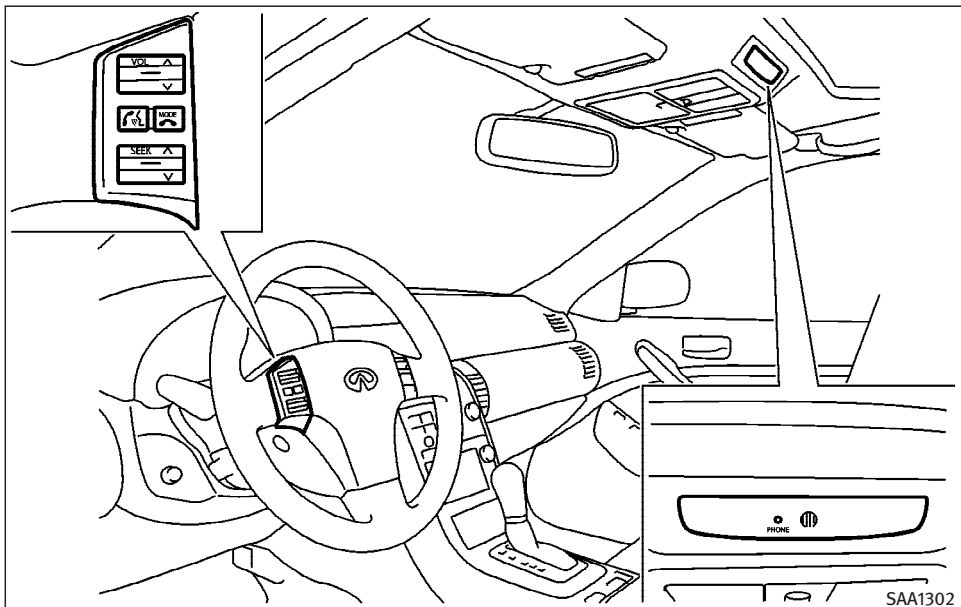

Your INFINITI is equipped with the Bluetooth® Hands-Free Phone System. If you are an owner of a Bluetooth® enabled cellular phone, you can set up the wireless connection between your cellular phone and the in-vehicle phone module.

With Bluetooth® wireless technology, you can make or receive a hands-free telephone call with your cellular phone in the vehicle.

Once your cellular phone is paired to the in-vehicle phone module, no other phone

connecting procedure is required. Your phone is automatically connected with the in-vehicle phone module when the ignition switch is turned to the ON position with the paired cellular phone turned on and carried in the vehicle.

You can register up to 5 different Bluetooth® cellular phones to the in-vehicle phone module. However, you can talk on only one cellular phone at a time.

Before using the Bluetooth® Hands-Free Phone System, refer to the following notes.

- Set up the wireless connection between a cellular phone and the in-vehicle phone module before using the Bluetooth® Hands-Free Phone System.
- Some Bluetooth® enabled cellular phones may not be recognized by the in-vehicle phone module. Please visit www.infiniti.com/bluetooth for a recommended phone list.
- You will not be able to use a hands-free phone under the following conditions:
 - Your vehicle is outside of the telephone service area.

- Your vehicle is in an area where it is difficult to receive radio waves; such as in a tunnel, in an underground parking garage, near a tall building or in a mountainous area.
- Your cellular phone is locked to prevent it from being dialed.

When the radio wave condition is not ideal or ambient sound is too loud, it may be difficult to hear the other person's voice during a call.

Do not place the cellular phone in an area surrounded by metal or far away from the in-vehicle phone module to prevent tone quality degradation and wireless connection disruption.

While a cellular phone is connected through the Bluetooth® wireless connection, the battery power of the cellular phone may discharge quicker than usual.

If the Bluetooth® Hands-Free Phone System seems to be malfunctioning, please refer to “Troubleshooting guide” later in this section. You can also visit www.infiniti.com/bluetooth for troubleshooting help.

Refer to the cellular phone Owner's Manual regarding the telephone charges, cellular phone antenna and body, etc.

This device complies with Part 15 of the FCC Rules. Operation is subject to the following two conditions: (1) this device may not cause harmful interference, and (2) this device must accept any interference received, including interference that may cause undesired operation.

FCC Radiation Exposure Statement:

This equipment complies with FCC radiation exposure limits set forth for an uncontrolled environment. This equipment should be installed and operated with minimum distance 8 inch (20 cm) between the radiator and your body. This Transmitter must not be co-located or operating in conjunction with any other antenna or transmitter.

USING THE SYSTEM

The INFINITI Voice Recognition system allows hands-free operation of the Bluetooth® Hands-Free Phone System.

If the vehicle is in motion, some commands may not be available so full attention may be given to vehicle operation.

Initialization

When the ignition switch is turned to the ON position, INFINITI Voice Recognition is initialized, which takes a few seconds. When completed, the amber light on the overhead console illuminates and the system is ready to accept voice commands. If the  button is pushed before the initialization completes, the system will announce “Hands-free phone system not ready” and will not react to voice commands.

Operating tips

To get the best performance out of the INFINITI Voice Recognition system, observe the following:

- Keep the interior of the vehicle as quiet as possible. Close the windows to eliminate surrounding noises (traffic noises, vibration sounds, etc.), which may prevent the system from recognizing voice commands correctly.
- Wait until the tone sounds before speaking a command. Otherwise, the command will not be received properly.
- Start speaking a command within 5 seconds after the tone sounds.

- Speak in a natural voice without pausing between words.

Giving voice commands

To operate INFINITI Voice Recognition, push and release the  button located on the steering wheel. The light on the overhead console flashes to signal you have entered a voice recognition (VR) session. After the tone sounds, speak a command.

The command given is picked up by the microphone, and voice feedback is given when the command is accepted.

- If you need to hear the available commands for the current menu again, say “Help” and the system will repeat them.
- If a command is not recognized, the system announces, “Command not recognized. Please try again.” Repeat the command in a clear voice.
- If you want to go back to the previous command, you can say “Go back” or “Correction” anytime the system is waiting for a response.
- You can cancel a command when the system is waiting for a response by

saying, “Cancel” or “Quit.” The system announces “Cancel” and ends the VR session. You can also push the  button on the steering wheel at any time. Whenever the VR session is cancelled, a double beep is played to indicate you have exited the system.

- If you want to adjust the volume of the voice feedback, push the volume control switches (+ or -) on the steering wheel while being provided with feedback. You can also use the radio volume control knob.

How to say numbers

INFINITI Voice Recognition requires a certain way to speak numbers in voice commands. Refer to the rules and examples below.

- Either “zero” or “oh” can be used for “0”.

Example: 1-800-662-6200

- “One eight oh oh six six two six two oh oh”, or
- “One eight zero zero six six two six two oh oh”

- Words can be used for the first 4 digit places only.

Example: 1-800-662-6200

- “One eight hundred six six two six two oh oh”,
- NOT “One eight hundred six six two sixty two hundred, and
- NOT “One eight oh oh six six two sixty two hundred.

- Numbers can be spoken in small groups. The system will prompt you to continuing entering digits, if desired.

Example: 1-800-662-6200

- “One eight oh oh”

The system repeats the numbers and prompts you to enter more.

- “six six two”

The system repeats the numbers and prompts you to enter more.

- “six two oh oh”

- You can say “Star” for * and “Pound” for # at anytime in any position of the phone number.

Example: 1-555-1212 *123

- “One five five five one two one two star one two three”

NOTE:

For best results, say phone numbers as single digits.

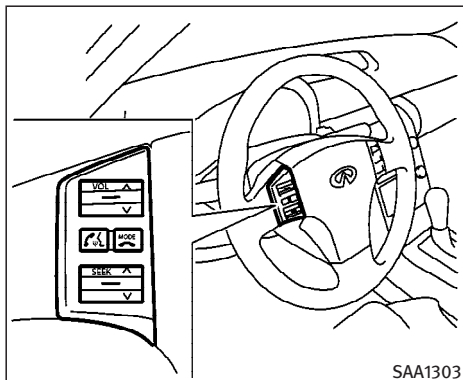

CONTROL BUTTONS

The control buttons for the Bluetooth® Hands-Free Phone System are located on the steering wheel.

TALK/PHONE SEND

Push the  button to initiate a VR session or answer an incoming call.

You can also use the  button to skip through system feedback and to enter commands during a call. See “List of voice commands” and “During a call” later in this section for more information.

MODE/PHONE END

Push the  button to cancel a VR session or end a call.



GETTING STARTED

The following procedures will help you get started using the Bluetooth® Hands-Free Phone System with INFINITI Voice Recognition. For additional command options, refer to “List of voice commands” later in this section.

Choosing a language

You can interact with the Bluetooth® Hands-Free Phone System using English, Spanish or French.

To change the language, perform the following.

1. Press and hold the  button for more than 5 seconds.
2. The system announces: “Press the PHONE/SEND () button for the hands-free phone system to enter the speaker adaptation mode or press the PHONE/END () button to select a different language.”

3. Press the **MODE** button.

For information on speaker adaptation, see “Speaker adaptation (SA) mode” later in this section.

4. The system announces the current language and gives you the option to change the language to Spanish (in Spanish) or French (in French). Use the following chart to select the language.

NOTE:

Note: You must press the  button or the **MODE button within 5 seconds to change the language.**

Current language	Press  (TALK/PHONE SEND) to select	Press MODE (MODE/PHONE END) to select
English	Spanish	French
Spanish	English	French
French	English	Spanish

5. If you decide not to change the language, do not press either button. After 5 seconds, the VR session will end, and the language will not be changed.

Pairing procedure

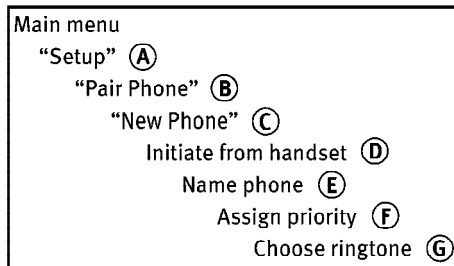

1. Push the  button on the steering wheel. The system announces the available commands.
2. Say: “Setup” **(A)**. The system acknowledges the command and announces the next set of available commands.
3. Say: “Pair phone” **(B)**. The system acknowledges the command and announces the next set of available commands.
4. Say: “New phone” **(C)**. The system acknowledges the command and asks you to initiate pairing from the phone handset **(D)**.

When you are asked to enter a PIN code for pairing your Bluetooth[®] cellu-

lar phone, operate it to enter the code “1234”.

The code is always “1234” regardless of the number of phones paired.

The pairing procedure of the cellular phone varies according to each cellular phone manufacturer. See the cellular phone Owner’s Manual for details. You can also visit www.infiniti.com/bluetooth for instructions on pairing INFINITI recommended cellular phones.

5. The system asks you to say a name for the phone **(E)**.

If the name is too long or too short, the system tells you, then prompts you for a name again.

Also, if more than one phone is paired and the name sounds too much like a name already used, the system tells you, then prompts you for a name again.

6. The system asks you to assign a priority level **(F)**. The priority level determines which phone is active when more than one paired Bluetooth[®] phone is in the vehicle. Follow the instructions provided by the system or

refer to “Setup” later in this section for more information on changing priorities.

- The system will ask if you would like to select a custom ring tone (G). Follow the instructions provided by the system or refer to “Setup” later in this section for more information on selecting ringtones.

Making a call by entering a phone number

Main menu

“Call” (A)

Number (speak digits) (B)

“Dial” (C)

- Push the  button on steering wheel. A tone will sound.
- Say: “Call” (A). The system acknowledges the command and announces the next set of available commands.
- Say the number you wish to call (B). For example, 555-1212 can be said as “five five five one two one two.” See “How to say numbers” earlier in this section for more information.

- When you have finished speaking the phone number, the system repeats it back and announces the available commands.
- Say: “Dial” (C). The system acknowledges the command and makes the call.

For additional command options, see “List of voice commands” later in this section.

Receiving a call

When you hear the ring tone, press the  button on the steering wheel.

Once the call has ended, press the  button on the steering wheel.

NOTE:

If you do not wish to take the call when you hear the ring tone, press the  button on the steering wheel to reject the call.

For additional command options, see “List of voice commands” later in this section.

LIST OF VOICE COMMANDS

Main menu

“Call”

“Phone Book”

“Memo Pad”

“Setup”

When you push and release the  button on the steering wheel, you can choose from the commands on the Main Menu. The following pages describe these commands and the commands in each sub-menu.

Remember to wait for the tone before speaking.



You can say “Help” to hear the list of commands currently available anytime the system is waiting for a response.

If you want to end an action without completing it, you can say “Cancel” or “Quit” at anytime the system is waiting for a response. The system will end the VR session. Whenever the VR session is cancelled, a double beep is played to indicate you have exited the system.

If you want to go back to the previous command, you can say “Go back” or “Cor-

rection” anytime the system is waiting for a response.

When you get used to the menus in the system, you can talk ahead by saying more than one command at a time. For example, say, “Call five five five one two one two” or “Memo pad record.”

Also, when you get used to the system responses, you can skip ahead to the tone by pressing the  button on the steering wheel. However, if you press the  button when the system is waiting for a response from you it will end the VR session.

“Call”

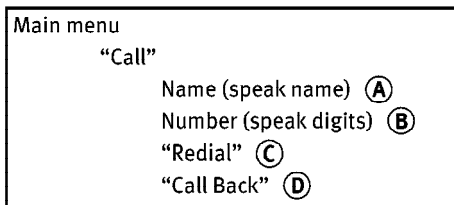

Name (speak name) (A)

If you have stored entries in the Phone Book, you can dial a number associated with a name and location.

See “Phone book” later in this section to learn how to store entries.

When prompted by the system, say the name of the phone book entry you wish to call. The system acknowledges the name.

If there are multiple locations associated with the name, the system asks you to choose the location.

Once you have confirmed the name and location, the system begins the call.

Number (speak digits) (B)

When prompted by the system, say the number you wish to call. Refer to “How to say numbers” and “Making a call by entering a phone number” earlier in this section for more details.

“Redial” (C)

Use the Redial command to call the last number that was dialed within the vehicle.

NOTE:

The system will not redial the last number dialed by the handset keypad.

The system acknowledges the command, repeats the number and begins dialing.

If a redial number does not exist, the system announces, “There is no number to redial” and ends the VR session.

“Call back” (D)

Use the Call Back command to dial the number of the last incoming call within the vehicle.

The system acknowledges the command, repeats the number and begins dialing. If a call back number does not exist, the system announces, “There is no number to call back” and ends the VR session.

During a call

During a call there are several command options available. Press the  button on the steering wheel to mute the receiving voice and enter commands.

- “Help” — The system announces the available commands.
- “Go back/Correction” — The system announces “Go back,” ends the VR session and returns to the call.
- “Cancel/Quit” — The system announces “Cancel,” ends the VR session and returns to the call.

- “Send/Enter/Call/Dial” — Use the Send command to enter numbers during a call. For example, if you were directed to dial an extension by an automated system:

Say: “Send one two three four.”

The system acknowledges the command and sends the tones associated with the numbers. The system then ends the VR session and returns to the call.

- “Transfer call” — Use the Transfer Call command to transfer the call from the Bluetooth® Hands-Free Phone System to the cellular phone when privacy is desired.

The system announces, “Transfer call. Call transferred to privacy mode.” The system then ends the VR session.

You can also issue the Transfer Call command again to return to a hands-free call through the vehicle.

- “Mute” — Use the Mute command to mute your voice so the other party cannot hear it. Use the mute command again to unmute your voice.

NOTE:

If the other party ends the call or the cellular phone network connection is lost while the Mute feature is on, the Mute feature may need to be reset to “off.”

“Phone book”

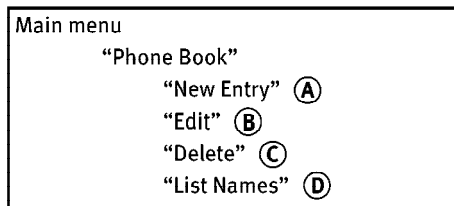

The Phone Book stores up to 40 names for each phone paired with the system. Each name can have up to 4 locations/phone numbers associated with it.

NOTE:

Each phone has its own separate phone book. You cannot access Phone A’s phone book if you are currently connected with Phone B.

“New entry” (A)

Use the New Entry command to store a new name in the system.

When prompted by the system, say the name you would like to give the new entry.

For example, say: “Mary.”

If the name is too long or too short, the system tells you, then prompts you for a name again.

Also, if the name sounds too much like a name already stored, the system tells you, then prompts you for a name again.

Once the system accepts the name and you confirm it is correct, the system asks for a location (Home, Office, Mobile or Other).

For example, say: “Home.”

The system acknowledges the location and asks for a number.

For example, say: “five five five one two one two.” See “How to say numbers” earlier in this section for more information.

The system repeats the number and prompts you for the next command. When you have finished entering numbers, choose “Store.”

The system confirms the name, location and number. The system then asks if you would like to store another location for the same name. If you do not wish to store another location, the system ends the VR session.

“Edit” (B)

Use the Edit command to alter an existing phone book entry or to add a 2nd, 3rd or 4th phone number to an existing entry.

When prompted by the system, say the name of the entry you wish to edit.

The system acknowledges the name and asks you for the location you would like to edit.

Say the name of the location. The system acknowledges and asks you for the phone number you would like to store with this location.

See “How to say numbers” earlier in this section for more information.

The system repeats the number and prompts you for the next command. When you have finished entering numbers, choose “Store.”

The system confirms the name, location and number, then announces that the en-

try has been stored. The system then ends the VR session.

“Delete” (C)

Use the Delete command to erase one entry from the phone book, all entries from the phone book, the current redial number or the current call back number.

To delete entries from the phone book, say a name or “All entries” when prompted by the system.

The system acknowledges the command and asks you to confirm the deletion.

To delete the current redial number or call back number, say “redial number” or “call back number” when prompted by the system.

If a redial number or a call back number exists, the system deletes them without asking for confirmation.

If there is no number for the entry you are trying to delete, the system says so and ends the VR session.

“List names” (D)

Use the List Names command to hear all the names and locations in the phone book.

The system recites the phone book entries but does not include the actual phone numbers. When the playback of the list is complete the system ends the VR session.

You can stop the playback of the list at any time by pressing the **MODE** button on the steering wheel. The system ends the VR session.

“Memo pad”

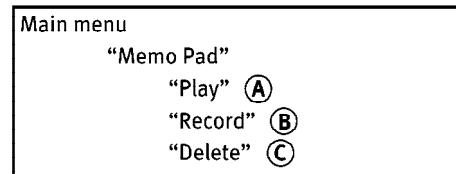

The Memo Pad records a maximum of 3 voice memos, each up to 20 seconds long.

“Play” (A)

The system plays back all the memos in the order of newest to oldest. The system ends the VR session.

If there are no memos recorded, the system announces “No messages to play.” The system ends the VR session.

“Record” **B**

The system announces “Recording” and a tone sounds signaling you to begin.

Speak the information you wish to record clearly. When you are done, press the  or **MODE** button on the steering wheel.

A tone sounds and the system announces “Memo recorded.” Another tone sounds to end the VR session.

If the memo pad is full, the system asks if you wish to record over the oldest memo.

“Delete” **C**

The Delete command erases all memos. The system asks you to confirm this action before deleting all memos.

“Setup”

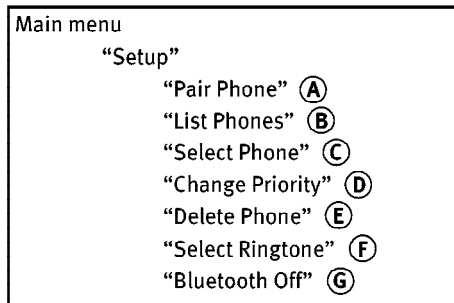

Use the Setup command to change options associated with the Bluetooth® Hands-Free Phone System.

“Pair phone” **A**

Use the Pair Phone command to pair a phone to the Bluetooth® Hands-Free Phone System.

When you are asked to enter a PIN code for pairing your Bluetooth® cellular phone, operate it to enter the code “1234”.

The code is always “1234” regardless of the number of phones paired.

Up to 5 phones can be paired. If you try to pair a sixth phone, the system announces

that you must first delete one phone or replace an existing phone.

If you try to pair a phone that has already been paired to your vehicle’s system, the system announces the name the phone is already using. The pairing procedure will then be cancelled.

When prompted by the system, choose from the following commands:

- “New phone” — Refer to “Pairing a phone” earlier in this section.
- “Replace phone” — The system announces the names of the phones already paired and asks which you would like to replace.

Once you say the name of the phone you wish to replace, the pairing procedure will begin. Refer to “Pairing procedure” earlier in this section.

- “List phone” — See the description below.

“List phones” **B**

Use the List Phone command to hear the names of the phones currently paired. If no phones are paired, the system announces, “No paired phones to list.” The system then ends the VR session.

“Select phone”

Use the Select Phone command to select a phone of lesser priority when two or more phones paired with Bluetooth[®] Hands-Free Phone System are in the vehicle at the same time.

The system asks you to name the phone and confirm the selection.

Once the selection is confirmed, the selected phone remains active until the ignition switch is turned OFF or you select a new phone.

“Change priority”

Use the Change Priority command to change the priority level of the active phone.

The priority level determines which phone is active when more than one paired Bluetooth[®] phone is in the vehicle.

The system states the priority level of the active phone and asks for a new priority level (1, 2, 3, 4, 5).

If the new priority level is already being used for another phone, the two phones will swap priority levels.

For example, if the current priority levels are:

Priority Level 1 = Phone A
Priority Level 2 = Phone B
Priority Level 3 = Phone C

and you change the priority level of Phone C to Level 1, then:

Priority Level 1 = Phone C
Priority Level 2 = Phone B
Priority Level 3 = Phone A

“Delete phone”

Use the Delete Phone command to delete a specific phone or all phones from the Bluetooth[®] Hands-Free Phone System.

The system announces the names of the phones already paired with the system and their priority level. The system then gives you the option to delete a specific phone, all phones or listen to the list again.

Once you chose to delete a phone or all phones, the system asks you to confirm this action.

NOTE:

When you delete a phone, the associated phone book for that phone will also be deleted.

“Select ringtone”

Use the Select Ringtone command to select the tone heard in the vehicle when an incoming call is received.

The system announces the name of the active phone and asks you to choose from the following commands:

- “Ringtone” — The system plays a ringtone and asks if you would like to select that tone. If you say no, the system plays the next ringtone available and continues to cycle through the ringtones until you select one or quit.
- “Silent” — The system asks you to confirm your wish to disable the ringtone.

“Bluetooth off”

Use the Bluetooth Off command to turn off the Bluetooth[®] Hands-Free Phone System.

When Bluetooth[®] Hands-Free Phone System is off, you will not be able to make or receive calls using INFINITI Voice Recognition. Also, you will not have access to the Phone Book.

You can still use the Memo Pad and access Setup.

To turn on the system again, choose the Bluetooth On command from the Setup command.

SPEAKER ADAPTATION (SA) MODE

Speaker Adaptation allows up to two out-of-dialect users to train the system to improve recognition accuracy. By repeating a number of commands, the users can create a voice model of their own voice that is stored in the system. The system is capable of storing a different speaker adaptation model for memory A and memory B.

If memory A is available, the system will use memory A to store the model. If memory A is in use and memory B is available, the system will use memory B to store the model. If both of the memory locations are in use, the system will ask the user to select which memory location should be overwritten.



Training procedure

The procedure for training a voice is as follows.

1. Position the vehicle in a reasonably quiet outdoor location.

2. Sit in the driver's seat with the engine running, the parking brake on, and the transmission in Park.

3. Press and hold the  button for more than 5 seconds.

4. The system announces: "Press the PHONE/SEND () button for the hands-free phone system to enter the speaker adaptation mode or press the PHONE/END ( MODE) button to select a different language."

5. Press the  button.

For information on selecting a different language, see "Choosing a language" earlier in this section.

6. Voice memory A or memory B is selected automatically. If both memory locations are already in use, the system will prompt you to overwrite one. Follow the instructions provided by the system.

7. When preparation is complete and you are ready to begin, the press the  button.

8. The SA mode will be explained. Follow the instructions provided by the system.

9. When training is finished, the system will tell you an adequate number of phrases have been recorded.

10. The system will ask you to say your name. Follow the instructions to register your name.

11. The system will announce that speaker adaptation has been completed and the system is ready.

The SA mode will stop if:

- The  button is pressed for more than 5 seconds in SA mode.
- The vehicle is driven during SA mode.
- The ignition switch is turned to the OFF or LOCK position.

Training phrases

During the SA mode, the system instructs you to say the following phrases.

(The system will prompt you for each phrase.)

- phone book new entry
- dial three oh four two nine
- delete call back number
- setup pair phone

- memo pad play
- eight pause nine three two pause seven
- delete all entries
- call seven two four zero nine
- phone book delete entry
- memo pad record
- dial star two one seven oh
- Yes
- No
- select ring tone
- dial eight five six nine two
- Bluetooth on
- setup change priority
- call three one nine oh two
- nine seven pause pause three oh eight
- Cancel
- call back number
- call star two zero nine five
- delete phone
- dial eight three zero five one
- Home
- four three pause two nine pause zero
- delete redial number
- phone book list names
- call eight oh five four one
- Correction
- setup change ring tone
- dial seven four oh one eight
- setup main menu
- Delete
- dial nine seven two six six
- memo pad delete
- call seven six three oh one
- go back
- call five six two eight zero
- dial six six four three seven

TROUBLESHOOTING GUIDE

The system should respond correctly to all voice commands without difficulty. If problems are encountered, try the following solutions.

Where the solutions are listed by number, try each solution in turn, starting with number 1, until the problem is resolved.

Symptom	Solution
System fails to interpret the command correctly.	1. Ensure that the command is valid. See “List of voice commands” earlier in this section.
	2. Ensure that the command is spoken after the tone.
	3. Speak clearly without pausing between words and at a level appropriate to the ambient noise level in the vehicle.
	4. Ensure that the ambient noise level is not excessive (for example, windows open or defroster on). NOTE: If it is too noisy to use the phone, it is likely that the voice commands will not be recognized.
	5. If more than one command was said at a time, try saying the commands separately.
	6. If the system consistently fails to recognize commands, the voice training procedure should be carried out to improve the recognition response for the speaker. See “Speaker adaptation (SA) mode” earlier in this section.
The system consistently selects the wrong entry from the phone book.	1. Ensure that the phone book entry name requested matches what was originally stored. This can be confirmed by using the “List Names” command. See “Phone book” earlier in this section.
	2. Replace one of the names being confused with a new name.

5 Starting and driving

Precautions when starting and driving.....	5-2	Cruise control	5-20
Exhaust gas (Carbon monoxide)	5-2	Precautions on cruise control	5-20
Three way catalyst.....	5-3	Cruise control operations	5-20
Tire pressure monitoring system (TPMS)	5-3	Break-in schedule	5-22
Avoiding collision and rollover.....	5-5	Increasing fuel economy	5-22
Drinking alcohol/drugs and driving	5-5	All-wheel drive (AWD) (if so equipped)	5-23
All-wheel drive (AWD) driving safety precautions (for AWD models)	5-6	All-wheel drive (AWD) warning light.....	5-23
Ignition switch (except Intelligent Key system).....	5-6	Parking/parking on hills	5-24
Automatic transmission	5-6	Power steering.....	5-25
Manual transmission	5-7	Brake system.....	5-26
Key positions	5-8	Braking precautions	5-26
INFINITI Vehicle Immobilizer System.....	5-8	Anti-lock brake system (ABS).....	5-26
Ignition switch (models with the Intelligent Key system).....	5-9	Vehicle Dynamic Control (VDC) system	5-28
Ignition switch positions	5-9	Rear active steer (RAS) system (if so equipped)	5-29
INFINITI Vehicle Immobilizer System	5-10	Cold weather driving.....	5-30
Before starting the engine.....	5-10	Freeing a frozen door lock.....	5-30
Starting the engine.....	5-11	Anti-freeze.....	5-30
Driving the vehicle	5-12	Battery	5-30
Automatic transmission.....	5-12	Draining of coolant water	5-30
Manual transmission	5-16	Tire equipment	5-30
Parking brake.....	5-19	Special winter equipment.....	5-31
		Driving on snow or ice	5-31
		Engine block heater (if so equipped)	5-32

PRECAUTIONS WHEN STARTING AND DRIVING



WARNING

- Do not leave children, impaired adults, or pets alone in your vehicle. They could accidentally injure themselves or others through inadvertent operation of the vehicle. Also, on hot, sunny days, temperatures in a closed vehicle could quickly become high enough to cause severe or possibly fatal injuries to people or animals.
- Closely supervise children when they are around cars to prevent them from playing and becoming locked in the trunk where they could be seriously injured. Keep the car locked, with the rear seatback and trunk lid securely latched when not in use, and prevent children's access to car keys.

EXHAUST GAS (Carbon monoxide)



WARNING

Do not breathe exhaust gases; they contain colorless and odorless carbon monoxide.

Carbon monoxide is dangerous. It can cause unconsciousness or death.

- If you suspect that exhaust fumes are entering the vehicle, drive with all windows fully open, and have the vehicle inspected immediately.
- Do not run the engine in closed spaces such as a garage.
- Do not park the vehicle with the engine running for any extended length of time.
- Keep the trunk lid closed while driving, otherwise exhaust gases could be drawn into the passenger compartment. If you must drive with the trunk lid open, follow these precautions:
 - Open all the windows.
 - Set the air recirculation switch OFF and the fan control at high to circulate the air.
- If electrical wiring or other cable connections must pass to a trailer through the seal on the trunk lid or the body, follow the manufacturer's recommendation

to prevent carbon monoxide entry into the vehicle.

- If a special body, camper, or other equipment is added for recreational or other usage, follow the manufacturer's recommendation to prevent carbon monoxide entry into the vehicle. (Some recreational vehicle appliances such as stoves, refrigerators, heaters, etc. may also generate carbon monoxide.)
- The exhaust system and body should be inspected by a qualified mechanic whenever:
 - Your vehicle is raised while being serviced.
 - You suspect that exhaust fumes are entering into the passenger compartment.
 - You notice a change in the sound of the exhaust system.
 - You have had an accident involving damage to the exhaust system, underbody, or rear of the vehicle.

THREE WAY CATALYST

The three way catalyst is an emission control device installed in the exhaust system. Exhaust gas in the converter is burned at high temperatures to help reduce pollutants.



WARNING

- The exhaust gas and the exhaust system are very hot. Keep people, animals or flammable materials away from the exhaust system components.
- Do not stop or park the vehicle over flammable materials such as dry grass, waste paper or rags. They may ignite and cause a fire.



CAUTION

- Do not use leaded gasoline. Deposits from leaded gasoline will seriously re-

duce the three-way catalyst's ability to help reduce exhaust pollutants.

- Keep your engine tuned up. Malfunctions in the ignition, fuel injection, or electrical systems can cause overrich fuel flow into the three-way catalyst, causing it to overheat. Do not keep driving if the engine misfires, or if noticeable loss of performance or other unusual operating conditions are detected. Have the vehicle inspected promptly by an INFINITI dealer.
- Avoid driving with an extremely low fuel level. Running out of fuel could cause the engine to misfire, damaging the three-way catalyst.
- Do not race the engine while warming it up.
- Do not push or tow your vehicle to start the engine.

TIRE PRESSURE MONITORING SYSTEM (TPMS)

Each tire, including the spare (if provided), should be checked monthly when cold and

inflated to the inflation pressure recommended by the vehicle manufacturer on the vehicle placard or tire inflation pressure label. (If your vehicle has tires of a different size than the size indicated on the vehicle placard or tire inflation pressure label, you should determine the proper tire inflation pressure for those tires.)

As an added safety feature, your vehicle has been equipped with a tire pressure monitoring system (TPMS) that illuminates a low tire pressure telltale when one or more of your tires is significantly under-inflated. Accordingly, when the low tire pressure telltale illuminates, you should stop and check your tires as soon as possible, and inflate them to the proper pressure. Driving on a significantly under-inflated tire causes the tire to overheat and can lead to tire failure. Under-inflation also reduces fuel efficiency and tire tread life, and may affect the vehicle's handling and stopping ability.

Please note that the TPMS is not a substitute for proper tire maintenance, and it is the driver's responsibility to maintain correct tire pressure, even if under-inflation has not reached the level to trigger illumination of the TPMS low tire pressure telltale.

Your vehicle has also been equipped with a TPMS malfunction indicator to indicate when the system is not operating properly. The TPMS malfunction indicator is combined with the low tire pressure telltale. When the system detects a malfunction, the telltale will flash for approximately one minute and then remain continuously illuminated. This sequence will continue upon subsequent vehicle start-ups as long as the malfunction exists. When the malfunction indicator is illuminated, the system may not be able to detect or signal low tire pressure as intended. TPMS malfunctions may occur for a variety of reasons, including the installation of replacement or alternate tires or wheels on the vehicle that prevent the TPMS from functioning properly. Always check the TPMS malfunction telltale after replacing one or more tires or wheels on your vehicle to ensure that the replacement or alternate tires and wheels allow the TPMS to continue to function properly.

Additional information

- The TPMS does not monitor the tire pressure of the spare tire.
- The TPMS will activate only when the vehicle is driven at speeds above 16 MPH (25 km/h). Also, this system may not de-

tect a sudden drop in tire pressure (for example a flat tire while driving).

- Tire pressure rises and falls depending on the heat caused by the vehicle's operation and the outside temperature. Low outside temperature can lower the temperature of the air inside the tire which can cause a lower tire inflation pressure. This may cause the low tire pressure warning light to illuminate. If the warning light illuminates in low ambient temperature, check the tire pressure for all four tires.

For additional information, see “Low tire pressure warning light” in the “2. Instruments and controls” section and “Tire pressure monitoring system (TPMS)” in the “6. In case of emergency” section.



WARNING

- If the low tire pressure warning light illuminates while driving, avoid sudden steering maneuvers or abrupt braking, reduce vehicle speed, pull off the road to a safe location and stop the vehicle as soon as possible. Serious vehicle damage could occur

and may lead to an accident and could result in serious personal injury. Check the tire pressure for all four tires. Adjust the tire pressure to the recommended COLD tire pressure shown on the Tire and Loading Information label to turn the low tire pressure warning light OFF. If you have a flat tire, replace it with a spare tire as soon as possible. (See “Flat tire” in the “6. In case of emergency” section for changing a flat tire.)

- When a spare tire is mounted or a wheel is replaced, tire pressure will not be indicated, the TPMS will not function and the low tire pressure warning light will flash. Contact your INFINITI dealer as soon as possible for tire replacement and/or system resetting.
- Replacing tires with those not originally specified by INFINITI could affect the proper operation of the TPMS.
- Do not inject any tire liquid or aerosol tire sealant into the tires, as this may cause a malfunction of the tire pressure sensors.

5-4 Starting and driving



CAUTION

Do not place metalized film or any metal parts (antenna, etc.) on the windows. This may cause poor reception of the signals from the tire pressure sensors, and the TPMS will not function properly.

FCC Notice:

Changes or modifications not expressly approved by the party responsible for compliance could void the user's authority to operate the equipment.

This device complies with Part 15 of the FCC Rules and RSS-210 of Industry Canada.

Operation is subject to the following two conditions: (1) This device may not cause harmful interference, and (2) this device must accept any interference received, including interference that may cause undesired operation of the device.

AVOIDING COLLISION AND ROLLOVER



WARNING

Failure to operate this vehicle in a safe and prudent manner may result in loss of control or an accident.

Be alert and drive defensively at all times. Obey all traffic regulations. Avoid excessive speed, high speed cornering, or sudden steering maneuvers. These driving practices could cause you to lose control of your vehicle. **As with any vehicle, a loss of control could result in a collision with other vehicles or objects, or cause the vehicle to rollover, particularly if the loss of control causes the vehicle to slide sideways.** Be attentive at all times, and avoid driving when tired. Never drive under the influence of alcohol or drugs (including prescription or over-the-counter drugs which may cause drowsiness). Always wear your seat belt as outlined in the "1. Safety — Seats, seat belts and supplemental restraint system" section and also instruct your passengers to do so.

Seat belts help reduce the risk of injury in collisions and rollovers. **In a rollover**

crash, an unbelted or improperly belted person is significantly more likely to be injured or killed than a person properly wearing a seat belt.

DRINKING ALCOHOL/DRUGS AND DRIVING



WARNING

Never drive under the influence of alcohol or drugs. Alcohol in the bloodstream reduces coordination, delays reaction time and impairs judgement. Driving after drinking alcohol increases the likelihood of being involved in an accident injuring yourself and others. Additionally, if you are injured in an accident, alcohol can increase the severity of the injury.

INFINITI is committed to safe driving. You must not drive under the influence of alcohol. Every year thousands of people are injured or killed in alcohol related accidents. Although the local laws vary on what is considered to be legally intoxicated, the fact is that alcohol affects all people differently and most people underestimate the effects of alcohol.

Remember, drinking and driving don't mix!

And that's true for drugs too (over the counter, prescription, and illegal drugs). Don't drive if your ability to operate your vehicle is impaired by alcohol, drugs, or some other physical condition.

ALL-WHEEL DRIVE (AWD) DRIVING SAFETY PRECAUTIONS (for AWD models)



WARNING

- Do not drive beyond the performance capability of the tires, even with AWD engaged. Accelerating quickly, sharp steering maneuvers or sudden braking may cause loss of control.
- Always use tires of the same type, size, brand, construction (bias, bias-belted or radial), and tread pattern on all four wheels. Install tire chains on the rear wheels when driving on slippery roads and drive carefully.

- This vehicle is not designed for off-road (rough road) use. Do not drive on sandy or muddy roads that tires may get stuck in.
- Do not place an AWD equipped vehicle on a two wheel dynamometer or raise two wheels off the ground and shift the transmission to any D (drive) or R (reverse) position. Doing so may result in transmission damage or unexpected vehicle movement which could result in serious vehicle damage or personal injury.
- Never operate the accelerator pedal with any wheels raised and the other wheels on the ground while jacking up or with any wheels on a roller and the other wheels on the ground. Otherwise, the vehicle could lurch forward or backward.
- When a wheel is off the ground due to an unlevel surface, do not spin the wheel excessively.

IGNITION SWITCH (except Intelligent Key system)

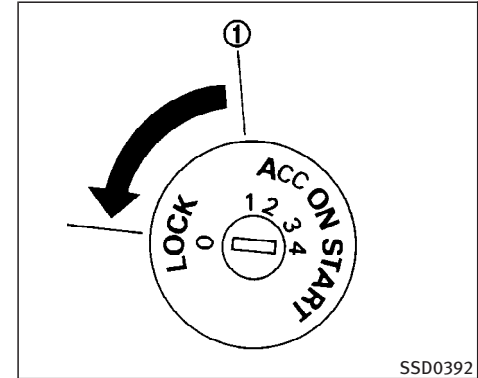

AUTOMATIC TRANSMISSION

The ignition lock is designed so the key cannot be turned to the LOCK position and removed until the selector lever is moved to the P (Park) position.

When removing the key from the ignition switch, make sure the selector lever is in the P (Park) position.

If the selector lever is not returned to the P (Park) position, the key cannot be moved to the LOCK position.

When the key cannot be turned toward the LOCK position, proceed as follows to remove the key:

1. Move the selector lever into the P position.
2. Turn the ignition key slightly toward the ON direction.
3. Turn the key to the LOCK position.
4. Remove the key.

If the key is removed from the ignition switch, the selector lever cannot be moved from the P position. **The selector lever can be moved if the ignition switch is in the ON position and the foot brake pedal is depressed.**

There is an OFF position ① in between the LOCK and ACC positions. The OFF position is indicated by a “1” on the key cylinder. When the ignition switch is in the OFF position, the steering wheel is not locked.

In order to lock the steering wheel, it must be turned about 1/6 of a turn counterclockwise from the straight up position.

To lock the steering wheel, turn the key to the LOCK position. Remove the key.

To unlock the steering wheel, insert the key and turn it gently while rotating the steering wheel slightly right and left.



WARNING

Never remove or turn the key to the LOCK position while driving. The steering wheel will lock. This may cause the driver to lose control of the vehicle and could result in serious vehicle damage or personal injury.

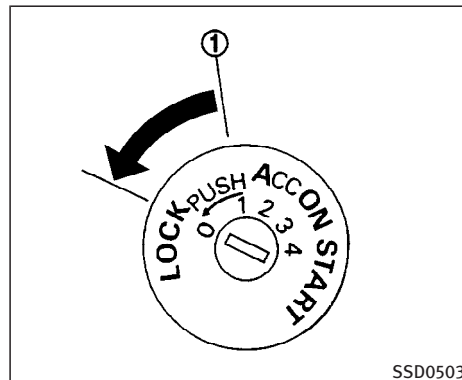

SSD0503

MANUAL TRANSMISSION

The ignition switch includes a device that helps prevent accidental removal of the key while driving.

The key can only be removed when the ignition switch is in the LOCK position.

To turn the ignition switch to the LOCK position from the ACC or ON position, turn the key to the OFF position, push the key in, then turn the key to the LOCK position.

There is an OFF position ① in between the LOCK and ACC positions. The OFF position is indicated by a “1” on the key cylinder.

In order for the steering wheel to be locked, it must be turned about 1/6 of a turn clockwise from the straight up position.

To lock the steering wheel, turn the key to the LOCK position. Remove the key.

To unlock the steering wheel, insert the key and turn it gently while rotating the steering wheel slightly right and left.



WARNING

Never remove or turn the key to the LOCK position while driving. The steering wheel will lock. This may cause the driver to lose control of the vehicle and could result in serious vehicle damage and/or personal injury.

KEY POSITIONS

The ignition switch includes an anti-theft steering lock device.

LOCK (Normal parking position) (0)

The ignition key can only be removed when the ignition switch is in this position.

OFF (1)

The engine can be turned off without locking the steering wheel.

The ignition lock is designed so that the key cannot be turned to the LOCK position and removed until the selector lever is moved to the P position (for automatic transmission) or the key is pushed in while turning the key between the ACC and LOCK positions.

ACC (Accessories) (2)

This position activates electrical accessories when the engine is not running.

ON (Normal operating position) (3)

This position activates ignition system in addition to electrical accessories.

START (4)

This position activates the starter motor, starting the engine.

INFINITI VEHICLE IMMOBILIZER SYSTEM

The INFINITI Vehicle Immobilizer System will not allow the engine to start without the use of the registered key.

If the engine fails to start using a registered key (for example, when interference is caused by another registered key, an automated toll road device or automated payment device on the key ring), restart the engine using the following procedures:

1. Leave the ignition switch in the ON position for approximately 5 seconds.
2. Turn the ignition switch to the OFF or LOCK position and wait approximately 10 seconds.
3. Repeat steps 1 and 2.
4. Restart the engine while holding the device (which may have caused the interference) away from the registered key.

If this procedure allows the engine to start, INFINITI recommends placing the registered key on a separate key ring to avoid interference from other devices.

IGNITION SWITCH (models with the Intelligent Key system)

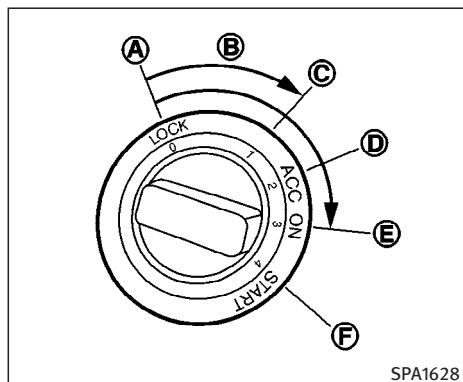

The ignition lock is designed so that the ignition switch cannot be turned to the LOCK position and removed until the selector lever is moved to the P (Park) position.

When turning the ignition switch, make sure the selector lever is in the P position.

If the selector lever is not returned to the P position, the ignition switch cannot be moved toward the LOCK position.

When the ignition switch cannot be turned toward the LOCK position, proceed as follows:

1. Move the selector lever into the P position.
2. Turn the ignition switch slightly in the ON direction.
3. Turn the key toward the LOCK position.

The selector lever can be moved from the P position if the ignition switch is in the ON position and the foot brake pedal is depressed.

There is an OFF position in between the LOCK and ACC positions, although it does not show on the lock cylinder. When the ignition is in the OFF position the steering wheel is not locked.

In order for the steering wheel to be locked, it must be turned about 1/6 of a turn counterclockwise from the straight up position.

To lock the steering wheel, turn the ignition switch to the LOCK position. To unlock the steering wheel, push the ignition switch in and turn it gently while rotating the steering wheel slightly right and left.

If the battery of the vehicle equipped with the Intelligent Key system is discharged, the ignition switch cannot be turned from

the LOCK position, even using the mechanical key or valet key.



WARNING

Never turn the ignition switch to the LOCK position while driving. The steering wheel will lock. This may cause the driver to lose control of the vehicle and could result in serious vehicle damage and/or personal injury.

IGNITION SWITCH POSITIONS

Push in the ignition switch to the (B) range when you turn it.

LOCK (Normal parking position):

The ignition switch can only be locked in the (A) position.

The ignition switch will be unlocked when it is pushed in, and turned to the ACC position (D) while carrying the Intelligent Key.

ACC (Accessories) (D):

This position activates electrical accessories such as the radio, when the engine is not running.

ON (Normal operating position) (E):

This position turns on the ignition system and electrical accessories.

START (F):

This position starts the engine. As soon as the engine has started, release the switch immediately. It will automatically return to the ON position.

For important safety information, see “Ignition switch” in the “5. Starting and driving” section.

The ignition switch cannot be turned back to the LOCK position unless the shift lever is in P position. (It can be turned to only (C).)



CAUTION

Do not leave the vehicle with the ignition switch in ACC or ON position when the engine is not running for an extended period. This can discharge the battery.

INFINITI VEHICLE IMMOBILIZER SYSTEM

The INFINITI Vehicle Immobilizer System will not allow the engine to start without the use of the registered key.

If the engine does not start using a registered key (for example, when interference is caused by another registered key, an automated toll road device or an automated payment device on the key ring), restart the engine using the following procedures:

1. Leave the ignition switch in the ON position for approximately 5 seconds.
2. Turn the ignition switch to the OFF or LOCK position and wait approximately 10 seconds.
3. Repeat steps 1 and 2.
4. Restart the engine while holding the device (which may have caused the interference) separate from the registered key.

If this procedure allows the engine to start, INFINITI recommends placing the registered key on a separate key ring to avoid interference from other devices.

BEFORE STARTING THE ENGINE

- Make sure the area around the vehicle is clear.
- Maintenance items should be checked periodically, for example, each time you check engine oil.
- Check that all windows and lights are clean.
- Visually inspect tires for their appearance and condition. Also check tires for proper inflation.
- Lock all doors.
- Position seat and adjust head restraints.
- Adjust inside and outside mirrors.
- Fasten seat belts and ask all passengers to do likewise.
- Check the operation of warning lights when the ignition key is turned to the ON position. See “Warning/indicator lights and audible reminders” in the “2. Instruments and controls” section.

STARTING THE ENGINE

1. Apply the parking brake.

2. **Automatic transmission:**

Move the selector lever to the P or N position. (P preferred.)

The starter is designed so that the starter does not operate unless the selector lever is in either one of the above positions.

Manual transmission:

Move the shift lever to the N position. Depress the clutch pedal fully to the floor.

The starter is designed so that it does not operate unless the clutch pedal is fully depressed.

3. Turn the ignition switch to START (4) to crank the engine **with your foot off the accelerator pedal**. Release the key when the engine starts.

If the engine starts, but fails to run, repeat the above procedure.

- If the engine is very hard to start in extremely cold weather or when re-starting, depress the accelerator pedal a little (approximately 1/3 to the floor) and while holding, crank the engine.

Release the key and the accelerator pedal when the engine starts.

- If the engine is very hard to start because it is flooded, depress the accelerator pedal all the way to the floor and hold it. Crank the engine for 5 to 6 seconds. After cranking the engine, release the accelerator pedal. Crank the engine **with your foot off the accelerator pedal** by turning the ignition key to the START position. Release the key when the engine starts. If the engine starts, but fails to run, repeat the above procedure.



CAUTION

Do not operate the starter for more than 15 seconds at a time. If the engine does not start, turn the key off and wait 10 seconds before cranking again, otherwise the starter could be damaged.

4. **Warm-up**

Allow the engine to idle for at least 30 seconds after starting. Do not race the engine while warming it up. Drive at moderate speed for a short distance first, especially in cold weather. In

cold weather, keep the engine running for a minimum of 2 - 3 minutes before shutting it off. Starting and stopping the engine over a short period of time may make the vehicle more difficult to start.

DRIVING THE VEHICLE

AUTOMATIC TRANSMISSION

5-speed automatic transmission

The automatic transmission in your vehicle is electronically controlled by a transmission control module to produce maximum efficiency and smooth operation.

Shown on the following pages are the recommended operating procedures for this transmission. Follow these procedures for maximum vehicle performance and driving enjoyment.

Starting the vehicle

After starting the engine, fully depress the foot brake pedal and push the selector lever button before shifting the selector lever to the R (Reverse), N (Neutral), D (Drive) or Manual shift mode position. Be sure the vehicle is fully stopped before attempting to shift the selector lever.

This automatic transmission model is designed so that the foot brake pedal must be depressed before shifting from P (Park) to any drive position while the ignition switch is the ON position.

The selector lever cannot be moved out of the P (Park) position and into any of the

5-12 Starting and driving

other gear positions if the ignition switch is turned to the LOCK, OFF or ACC position or if the key is removed from the switch.

1. Keep the foot brake pedal depressed and push the selector lever button to shift into a driving gear.
2. Release the parking brake and foot brake, then gradually start the vehicle in motion.



WARNING

- Do not depress the accelerator pedal while shifting from P (Park) or N (Neutral) to R (Reverse), D (Drive) or manual shift mode. Always depress the brake pedal until shifting is completed. Failure to do so could cause you to lose control and have an accident.
- Cold engine idle speed is high, so use caution when shifting into a forward or reverse gear before the engine has warmed up.
- On slippery roads, do not downshift. This may cause a loss of control.

- Never shift to P (Park) or R (Reverse) while vehicle is moving forward. Never shift to P (Park) or D (Drive) while vehicle is moving rearward. Failure to do so could cause you to lose control and have an accident.



CAUTION

When stopping the vehicle on an uphill grade, do not hold the vehicle by depressing the accelerator pedal. The foot brake should be used for this purpose.

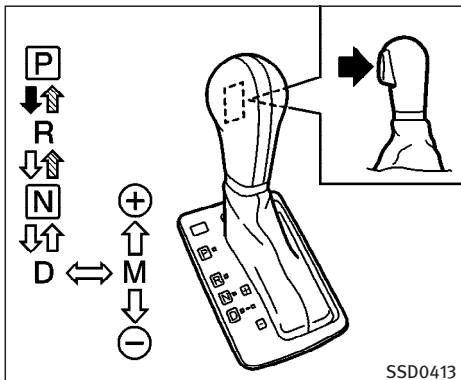

To move the selector lever,

- ➡ : Push the button while depressing the brake pedal,
- ➡ (with hatched button) : Push the button,
- ➡ (with arrow) : Just move the selector lever.

Shifting

After starting the engine, fully depress the brake pedal and shift the selector lever from the P (Park) to R (Reverse), N (Neutral), D (Drive), or Manual shift mode position.

Push the button to shift into the P (Park) or R (Reverse) position. All other positions

can be selected without pushing the button.



WARNING

Apply the parking brake if the selector lever is in any position while the engine is not running. Failure to do so could cause the vehicle to move unexpectedly or roll away and result in serious personal injury or property damage.

If the key is turned to the OFF or ACC position for any reason while the vehicle is in the R (Reverse), N (Neutral), or any D (Drive) position, the key cannot be turned to the LOCK position and be removed from the ignition switch. Move the selector lever to the P (Park) position, then the key can be turned to the LOCK position.

P (Park):

Use this selector position when the vehicle is parked or when starting the engine. Make sure the vehicle is completely stopped. **The brake pedal must be depressed and the selector lever button pushed in to move the selector lever from**

the N (Neutral) position or any drive position to the P (Park) position. Apply the parking brake. When parking on a hill, first depress the foot brake pedal, apply the parking brake, then move the lever to the P (Park) position.



CAUTION

Use this position only when the vehicle is completely stopped.

R (Reverse):

Use this position to back up. Always be sure the vehicle is completely stopped before selecting the R (Reverse) position. **The brake pedal must be depressed and the selector lever button pushed in to move the selector lever from the P (Park), N (Neutral) or any drive position to the R (Reverse) position.**

N (Neutral):

Neither forward nor reverse gear is engaged. The engine can be started in this position. You may shift to the N (Neutral) position and restart a stalled engine while the vehicle is moving.

D (Drive):

Use this position for all normal forward driving.

Manual shift mode

When the selector lever is shifted from the D position to the manual shift gate with the vehicle stopped or while driving, the transmission enters the manual shift mode. Shift range can be selected manually.

In the manual shift mode, the shift range is displayed on the position indicator in the meter.

Shift ranges up or down one by one as follows:

1_M → 2_M → 3_M → 4_M → 5_M
 ← ← ← ←

5_M (5th):

Use this position for all normal forward driving.

4_M (4th):

For driving up or down long slopes where engine braking would be advantageous.

3_M (3rd) and 2_M (2nd):

Use for hill climbing or engine braking on downhill grades.

1_M (1st):

Use this position when climbing steep hills slowly or driving slowly through deep snow, sand or mud, or for maximum engine braking on steep downhill grades.

- Remember not to drive at high speeds for extended periods of time in lower than 4_M range. This reduces gas mileage.
- When shifting up, move the selector lever to the + (up) side. (Shifts to higher range.)
- When shifting down, move the selector lever to the – (down) side. (Shifts to lower range.)
- Moving the selector lever rapidly to the same side twice will shift the ranges in succession.
- When canceling the manual shift mode, return the selector lever to the D position. The transmission returns to the normal driving mode.

- **In the manual shift mode, the transmission may not shift to the selected gear. This helps maintain driving performance and reduces the chance of vehicle damage or loss of control.**

In the manual shift mode, the transmission automatically shifts down to 1st gear before the vehicle comes to a stop. When accelerating again, it is necessary to shift up to the desired range.

Accelerator downshift

— In D position —

For passing or hill climbing, fully depress the accelerator pedal to the floor. This shifts the transmission down into the lower gear, depending on the vehicle speed.

Fail-safe

When the fail-safe operation occurs, the automatic transmission will be locked in the 4th gear.

If the vehicle is driven under extreme conditions, such as excessive wheel spinning and subsequent hard braking, the fail-safe system may be activated. This will occur even if all electrical circuits are functioning properly. In this case, turn the ignition

switch to the OFF position and wait for 3 seconds. Then turn the key back to the ON position. The vehicle should return to its normal operating condition. If it does not return to its normal operating condition, have an INFINITI dealer check the transmission and repair if necessary.

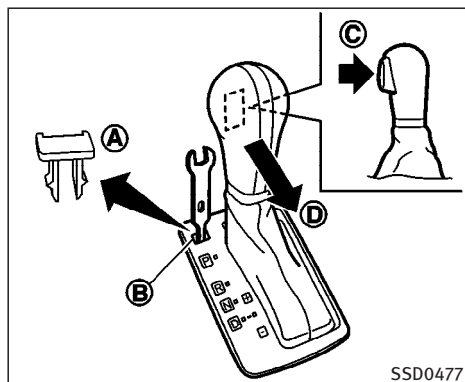

Shift lock release

If the battery charge is low or discharged, the selector lever may not be moved from the P (Park) position even with the brake pedal depressed and the selector lever button pushed.

To move the selector lever, release the shift lock and push the selector lever button. The selector lever can be moved to the N (Neutral) position. However, the steering wheel will be locked unless the ignition switch is turned to the ON position.

To release the shift lock, complete the following procedure:

1. Turn the ignition switch to the LOCK position and remove the key.
2. Apply the parking brake.
3. Remove the shift lock cover (A) using a suitable tool.
4. Insert a suitable tool in the shift lock slot, and push down (B).
5. Push the selector lever button (C) and move the selector lever to the N (Neutral) position (D) while holding down the shift lock.
6. Turn the ignition switch to the ON position to unlock the steering wheel. Now the vehicle may be moved to the desired location.

If the lever cannot be moved out of the P (Park) position, have an INFINITI dealer check the automatic transmission system as soon as possible.

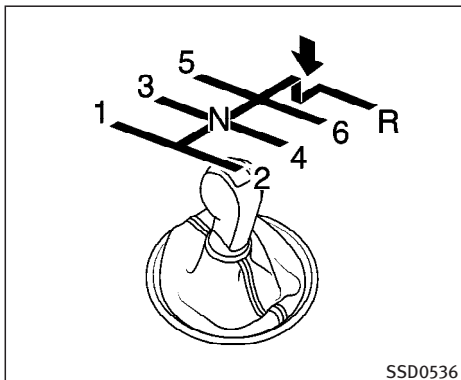

MANUAL TRANSMISSION

Shifting

To change gears, or when up shifting or down shifting, fully depress the clutch pedal, shift into the appropriate gear, then slowly and smoothly release the clutch.

This vehicle is equipped with a short throw shifter manual transmission. To ensure smooth gear changes, fully depress the clutch pedal before operating the shift lever. If the clutch pedal is not fully depressed before the transmission is

5-16 Starting and driving

shifted, a gear noise may be heard. Transmission damage could occur.

Start the vehicle in 1st gear and shift to 2nd, 3rd, 4th, 5th and 6th gear in sequence according to the vehicle speed.

To back up, depress the shift lever and then move it to the R (Reverse) position after stopping the vehicle completely.

If it is difficult to move the shift lever into the R (Reverse) or 1 position (Low gear), shift to the N (Neutral) position, and then release the clutch pedal once. Fully depress the clutch pedal again and shift into the R or 1 position.



WARNING

- Do not downshift abruptly on slippery roads. This may cause a loss of control.
- Do not over-rev the engine when shifting to a lower gear. This may cause a loss of control or engine damage.



CAUTION

- Do not rest your foot on the clutch pedal while driving. This may damage the clutch.
- Fully depress the clutch pedal before shifting to help prevent transmission damage.
- Stop your vehicle completely before shifting into R (Reverse).
- When the vehicle is stopped for a period of time, for example at a stop light, shift to N (Neutral) and release the clutch pedal with the foot brake applied.

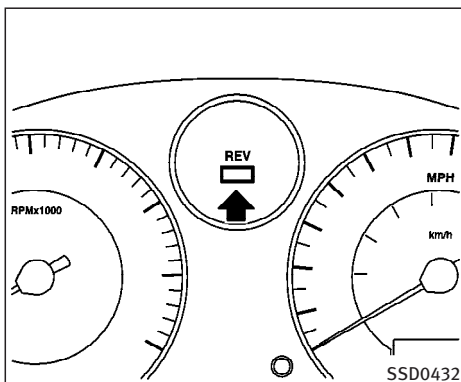

Up-shift indicator

The manual transmission up-shift indicator is located in the meter and shows the driver the timing to shift into a higher gear by illuminating. The use of the up-shift indicator will help you to upshift at a constant engine speed (rpm) from any gear.

The up-shift indicator will start flashing when the engine speed is within about 500 rpm of the set figure while driving, and then illuminate after the engine speed reaches the set figure.

Use the up-shift indicator when driving as follows:

- If the maximum engine speed is desired, set the figure at 7,000 rpm. (The indicator starts flashing from about 6,500 rpm and comes on steady at 7,000 rpm.)
- If the maximum engine torque is desired, set the figure at 4,800 rpm. (The indicator starts flashing from about 4,300 rpm and comes on steady at 4,800 rpm.)
- If you want to break in your vehicle, use of the up-shift indicator with a rather low figure will help you to avoid the high engine speed.

To make the up-shift indicator not come on, set the figure at above 7,900 rpm.

There may be a slight difference between the timing of the up-shift indicator illumination and the tachometer indication.

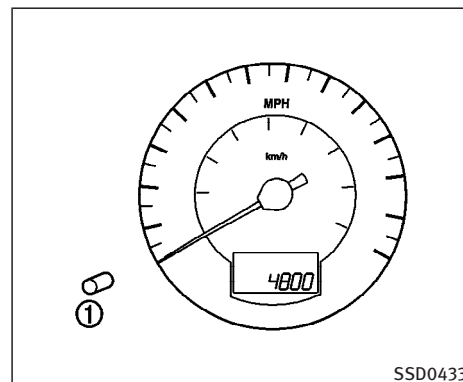

Up-shift indicator setting:

The desired engine speed (rpm) for the up-shift indicator can be set while the up-shift indicator setting mode is selected. Change the display to the up-shift indicator mode by pushing the trip odometer reset switch ①. When the up-shift indicator setting mode is selected, the engine speed currently set is displayed. (The initial factory setting is 8,000 rpm.) The figure can be changed between 2,000 and 8,000 rpm.

Push the trip odometer reset switch more than approximately 2 seconds and then the figure in the display will start blinking.

Pushing the trip odometer reset switch for less than approximately 1 second while the figure is blinking will add the figure by 100 rpm. If pushing for more than approximately 1 second, the figure will increase by 500 rpm.

If you have not operated the trip odometer reset switch for 5 seconds, the setting mode will end. The display will illuminate instead of blink.

If the battery cable is disconnected, the set engine speed will be returned to the initial figure (8,000 rpm).

Suggested up-shift speeds

Shown below are suggested vehicle speeds for shifting into a higher gear. These suggestions relate to fuel economy and vehicle performance. Actual up-shift speeds will vary according to road conditions, the weather and individual driving habits.

For normal acceleration in low altitude areas [less than 4,000 ft (1,219 m)]:

Gear change	MPH (km/h)
1st to 2nd	8 (13)
2nd to 3rd	16 (25)
3rd to 4th	25 (40)
4th to 5th	30 (50)
5th to 6th	33 (53)

For quick acceleration in low altitude areas or in high altitude areas [over 4,000 ft (1,219 m)]:

Gear change	MPH (km/h)
1st to 2nd	15 (24)
2nd to 3rd	25 (40)
3rd to 4th	40 (64)
4th to 5th	45 (72)
5th to 6th	50 (80)

Suggested maximum speed in each gear

Downshift to a lower gear if the engine is not running smoothly, or if you need to accelerate.

Do not exceed the maximum suggested speed (shown below) in any gear. For level road driving, use the highest gear suggested for that speed. Always observe

posted speed limits, and drive according to the road conditions, which will ensure safe operation. Do not over-rev the engine when shifting to a lower gear as it may cause engine damage or loss of vehicle control.

Gear	MPH (km/h)
1st	35 (56)
2nd	60 (96)
3rd	90 (144)
4th	—
5th	—
6th	—

PARKING BRAKE

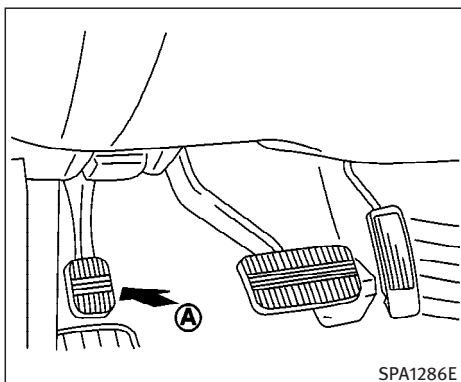

Automatic transmission model

To apply: Fully depress the parking brake pedal **(A)**.

To release:

1. Firmly apply the foot brake.
2. Depress the parking brake pedal **(A)** and the parking brake will be released.
3. Before driving, be sure the brake warning light goes out.

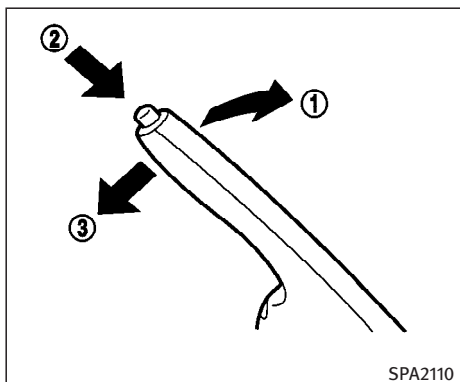

Manual transmission model

To apply: Pull the parking brake lever up **(1)**.

To release:

1. Firmly apply the foot brake.
2. Place the shift lever in the N (Neutral) position.
3. While pulling up on the parking brake lever slightly, push the button **(2)** and lower the lever completely **(3)**.
4. Before driving, be sure the brake warning light goes out.



WARNING

- Be sure the parking brake is fully released before driving. Failure to do so can cause brake failure and lead to an accident.
- Do not release the parking brake from outside the vehicle.
- Do not use the gear shift in place of the parking brake. When parking, be sure the parking brake is fully engaged.
- Do not leave children unattended in a vehicle. They could release the parking brake and cause an accident.

CRUISE CONTROL



WARNING

Do not use the cruise control when driving under the following conditions:

- When it is not possible to keep the vehicle at a set speed.
- In heavy traffic or in traffic that varies in speed.
- On winding or hilly roads.
- On slippery roads (rain, snow, ice, etc.).
- In very windy areas.

Doing so could cause a loss of vehicle control and result in an accident.



CAUTION

On manual transmission models, do not shift into N (Neutral) without depressing the clutch pedal when the cruise control is set. Should this occur, depress the clutch pedal and turn the main switch off immediately. Failure to do so may cause engine damage.

PRECAUTIONS ON CRUISE CONTROL

- If the cruise control system malfunctions, it cancels automatically. The SET indicator light on the instrument panel then blinks to warn the driver.
- If the engine coolant temperature becomes excessively high, the cruise control system will be canceled automatically.
- If the SET indicator light blinks, turn the cruise control MAIN switch off and have the system checked by an INFINITI dealer.
- The SET indicator light may blink when the cruise control MAIN switch is turned on while pushing the RESUME/ACCELERATE, SET/COAST, or CANCEL switch. To properly set the cruise control system, perform the following procedures.

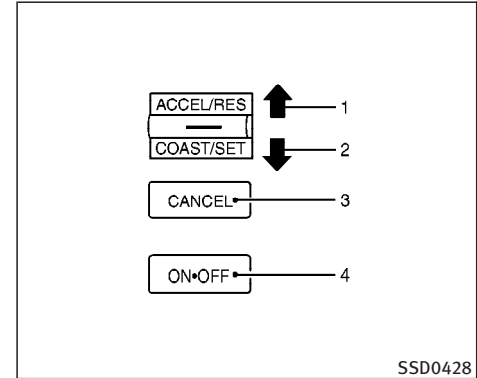

1. RESUME/ACCELERATE switch
2. SET/COAST switch
3. CANCEL switch
4. MAIN (ON-OFF) switch

CRUISE CONTROL OPERATIONS

The cruise control allows driving at a speed between 25 to 89 MPH (40 to 144 km/h) without keeping your foot on the accelerator pedal.

To turn on the cruise control, push the MAIN switch on. The CRUISE indicator light on the instrument panel will come on.

To set at cruising speed, accelerate your vehicle to the desired speed, push the SET/COAST switch and release it. (The SET indicator light will come on.) Take your foot off the accelerator pedal. Your vehicle will maintain the set speed.

- **To pass another vehicle**, depress the accelerator pedal. When you release the pedal, the vehicle will return to the previously set speed.
- The vehicle may not maintain the set speed when going up or down steep hills. If this happens, drive without the cruise control.

To cancel the preset speed, follow either of these three methods:

- a) Push the CANCEL switch. The SET indicator light will go out.
 - b) Tap the brake pedal. The SET indicator light will go out.
 - c) Turn the MAIN switch off. Both the CRUISE indicator and SET indicator lights will go out.
- If you depress the brake pedal while pushing the RESUME/ACCELERATE switch and reset at the cruising speed, turn the MAIN switch off once and then turn it on again.

- The cruise control will automatically be cancelled if the vehicle slows down below approximately 8 MPH (13 km/h).
- If you depress the clutch pedal (manual transmission), or move the selector lever to the N (Neutral) position (automatic transmission), the cruise control will be canceled.

To reset at a faster cruising speed, use one of the following methods:

- a) Depress the accelerator pedal. When the vehicle reaches the desired speed, push and release the SET/COAST switch.
- b) Push and hold the RESUME/ACCELERATE switch. When the vehicle reaches the speed you desire, release the switch.
- c) Push, then quickly release the RESUME/ACCELERATE set switch. This will increase the vehicle speed by about 1 MPH (1.6 km/h).

To reset at a slower cruising speed, use one of the following methods:

- a) Lightly tap the brake pedal. When the vehicle reaches the desired speed, push the SET/COAST switch and release it.
- b) Push and hold the SET/COAST switch. Release the switch when the vehicle slows down to the desired speed.
- c) Push, then quickly release the SET/COAST switch. This will decrease the vehicle speed by about 1 MPH (1.6 km/h).

To resume the preset speed, push and release the RESUME/ACCELERATE switch. The vehicle will resume the last set cruising speed when the vehicle speed is over 25 MPH (40 km/h).

BREAK-IN SCHEDULE



CAUTION



During the first 1,200 miles (2,000 km), follow these recommendations to obtain maximum engine performance and ensure the future reliability and economy of your new vehicle. Failure to follow these recommendations may result in shortened engine life and reduced engine performance.

- Avoid driving for long periods at constant speed, either fast or slow. Do not run the engine over 4,000 rpm.
- Do not accelerate at full throttle in any gear.
- Avoid quick starts.
- Avoid hard braking as much as possible.
- Do not tow a trailer or haul a heavy load for the first 500 miles (800 km).

INCREASING FUEL ECONOMY

- Accelerate slowly and smoothly. Maintain cruising speeds with a constant accelerator position.
 - Drive at moderate speeds on the highway. Driving at high speed will lower fuel economy.
 - Avoid unnecessary stopping and braking. Maintain a safe distance behind other vehicles.
 - Use a proper gear range which suits road conditions. On level roads, shift into high gear as soon as possible.
 - Avoid unnecessary engine idling.
 - Keep your engine tuned up.
 - Follow the recommended periodic maintenance schedule.
 - Keep the tires inflated at the correct pressure. Low pressure will increase tire wear and waste fuel.
 - Keep the front wheels in correct alignment. Improper alignment will cause not only tire wear but also lower fuel economy.
 - Air conditioner operation lowers fuel economy. Use the air conditioner only when necessary.
- When cruising at highway speeds, it is more economical to use the air conditioner and leave the windows closed to reduce drag.

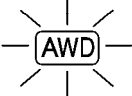
ALL-WHEEL DRIVE (AWD) (if so equipped)

Warning light	Comes on or blinks when
 Comes on	There is a malfunction in the all wheel drive system.
 Blinks rapidly	The power train oil temperature rises extremely high.
 Blinks slowly	The difference in wheel rotation is large.

SSD0336A

The full-time all-wheel drive (AWD) system automatically changes the driving mode.

ALL-WHEEL DRIVE (AWD) WARNING LIGHT

The AWD warning light is located on the instrument panel.

The AWD warning light comes on when the ignition switch is turned to the ON position. It turns off soon after the engine is started.

If any malfunction occurs in the AWD system while the engine is running, the warning light will come on.

The warning light may blink rapidly (about twice per second) while trying to free a stuck vehicle due to high power train oil temperature. The driving mode may change to 2 wheel drive. If the warning light blinks rapidly during operation, stop the vehicle with the engine idling in a safe place immediately. Then if the light goes off after a while, you can continue driving.

A large difference between the diameters of front and rear wheels will make the warning light blink slowly (about once per two seconds). Pull off the road in a safe area, and idle the engine. Check that all tire sizes are the same, tire pressure is correct and tires are not worn.

If the warning light is blinking after the above operation, have your vehicle checked by an INFINITI dealer as soon as possible.



WARNING

Do not attempt to test an AWD equipped vehicle with two wheels on a two wheel dynamometer and the other two wheels raised. Doing so may result in transmission damage or unexpected vehicle movement which could result in serious vehicle damage or personal injury.



CAUTION

- Do not operate the engine on a free roller when any of the wheels are raised.
- If the warning light comes on while driving there may be a malfunction in the AWD system. Reduce the vehicle speed and have your vehicle checked by an INFINITI dealer as soon as possible.
- Never drive on dry hard surface roads in the SNOW mode, as this will overload the power train and may cause a serious malfunction.

PARKING/PARKING ON HILLS

- If the warning light remains on after the above operation, have your vehicle checked by an INFINITI dealer as soon as possible.
- The power train may be damaged if you continue driving with the warning light blinking rapidly.

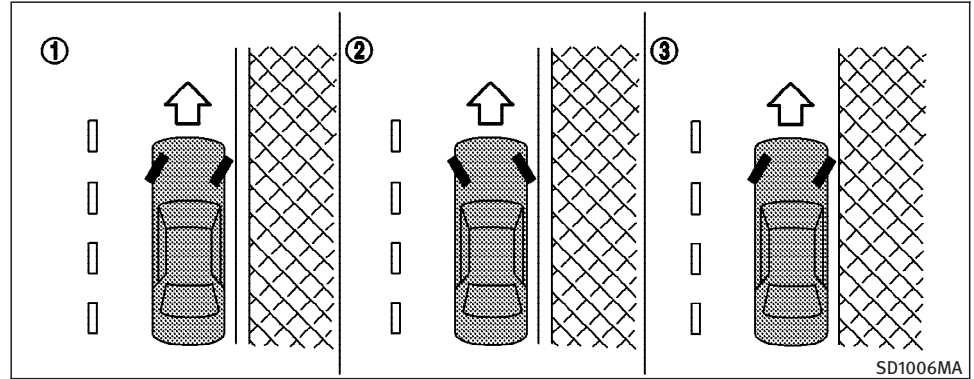

WARNING

- Do not stop or park the vehicle over flammable materials such as dry grass, waste paper or rags. They may ignite and cause a fire.
- Never leave the engine running while the vehicle is unattended.
- Never leave children unattended inside the vehicle.

- Safe parking procedures require that both the parking brake be set and the transmission placed into P (Park). Failure to do so could cause the vehicle to move unexpectedly or roll away and result in an accident.
- Make sure the shift lever has been pushed as far forward as it can go and cannot be moved without depressing the button at the end of the lever.

1. Firmly apply the parking brake.

2. **Automatic transmission models:**

Move the selector lever to the P (Park) position.

Manual transmission models:

Place the shift lever in the R (Reverse) position. When parking on an uphill grade, place the shift lever in the 1 (Low gear) position.

3. To help prevent the vehicle from rolling into the street when parked on a sloping drive way, it is a good practice to turn the wheels as illustrated.

• HEADED DOWNHILL WITH CURB: ①

Turn the wheels into the curb and move the vehicle forward until the curb side wheel gently touches the curb.

• HEADED UPHILL WITH CURB: ②

Turn the wheels away from the curb and move the vehicle back until the curb side wheel gently touches the curb.

• HEADED UPHILL OR DOWNHILL, NO CURB: ③

Turn the wheels toward the side of the road so the vehicle will move away from the center of the road if it moves.

4. Turn the ignition switch to the LOCK position and remove the key.

POWER STEERING

The power assisted steering uses a hydraulic pump, driven by the engine, to assist steering.

If the engine stops or the drive belt breaks, you will still have control of the vehicle. However, much greater steering effort is needed, especially in sharp turns or at low speeds.



WARNING

If the engine is not running or is turned off while driving, the power assist for the steering will not work. Steering will be much harder to operate.

BRAKE SYSTEM

BRAKING PRECAUTIONS

The brake system has two separate hydraulic circuits. If one circuit malfunctions, you will still have braking ability at two wheels.

Vacuum assisted brake

The brake booster aids braking by using engine vacuum. If the engine stops, you can stop the vehicle by depressing the brake pedal. However, greater foot pressure on the brake pedal will be required to stop the vehicle and the stopping distance will be longer.

Wet brakes

When the vehicle is washed or driven through water, the brakes may get wet. As a result, your braking distance will be longer and the vehicle may pull to one side during braking.

To dry brakes, drive the vehicle at a safe speed while lightly tapping the brake pedal to heat-up the brakes. Do this until the brakes return to normal. Avoid driving the vehicle at high speeds until the brakes function correctly.

Parking brake break-in

Break-in the parking brake shoes whenever the stopping effect of the parking

5-26 **Starting and driving**

brake is weakened or whenever the parking brake shoes and/or drums/rotors are replaced, in order to assure the best braking performance.

This procedure is described in the vehicle service manual and can be performed by your INFINITI dealer.

Using the brakes

Avoid resting your foot on the brake pedal while driving. This will cause overheating of the brakes, increases wear on the brakes and pads, and reduces gas mileage.

To help save the brakes and to prevent the brakes from overheating, reduce speed and downshift to a lower gear before going down a slope or long grade. Overheated brakes may reduce braking performance and could result in loss of vehicle control.



WARNING

- **While driving on a slippery surface, be careful when braking, accelerating or downshifting. Abrupt braking or accel-**

erating could cause the wheels to skid and result in an accident.

- **If the engine is not running or is turned off while driving, the power assist for the brakes will not work. Braking will be harder.**

ANTI-LOCK BRAKE SYSTEM (ABS)

The anti-lock brake system (ABS) controls the brakes so the wheels will not lock when braking abruptly or when braking on slippery surfaces. The system detects the rotation speed at each wheel and varies the brake fluid pressure to prevent each wheel from locking and sliding. By preventing wheel lockup, the system helps the driver maintain steering control and helps to minimize swerving and spinning on slippery surfaces.

Using the system

Depress the brake pedal and hold it down.



WARNING

Do not pump the brake pedal. Doing so may result in increased stopping distances.

Normal operation

The ABS will not operate at speeds below 3 to 6 MPH (5 to 10 km/h) to stop the vehicle. (The speeds will vary according to road conditions.) When the anti-lock system senses that one or more wheels are close to locking up, the actuator (under the hood) rapidly applies and releases hydraulic pressure (like pumping the brakes very quickly). While the actuator is working, you may feel a pulsation in the brake pedal and hear a noise or vibration from the actuator under the hood. This is normal and indicates that the ABS is working properly. However, the ABS operation may indicate that road conditions are hazardous and extra care is required while driving.

Self-test feature

The anti-lock brake system consists of electronic sensors, electric pumps, and hydraulic solenoids controlled by a com-

puter. The computer has a built-in diagnostic feature that tests the system each time you start the engine and move the vehicle at a low speed in forward or reverse. When the self-test occurs, you may hear a clunk noise and/or feel a pulsation in the brake pedal. This is normal and is not an indication of any malfunction. If the computer senses any malfunction, it switches the ABS off and turns on the ABS warning light in the instrument panel. The brake system operates normally, but without anti-lock assistance.

If the light comes on during the self-test or while driving, take the vehicle to an INFINITI dealer for repair.



WARNING

The anti-lock brake system is a sophisticated device, but it cannot prevent accidents resulting from careless or dangerous driving techniques. It can help maintain vehicle control during braking on slippery surfaces, but remember that the stopping distance on slippery surfaces will be longer than on normal surfaces even with the anti-lock brake

system. Stopping distances may also be longer on rough, gravel or snow covered roads, or if you are using tire chains. Always maintain a safe distance from the vehicle in front of you. Ultimately, the responsibility for safety of self and others rests in the hands of the driver.

Tire type and condition of tires may also affect braking effectiveness.

- **When replacing tires, install the specified size of tires to the front and rear.**
- **When installing a spare tire, make sure it is the proper size and type as specified on the Tire and Loading Information label. See “Vehicle identification” in the “9. Technical and consumer information” section for the Tire and Loading Information label location.**

VEHICLE DYNAMIC CONTROL (VDC) SYSTEM

When accelerating or driving on a slippery surface, the tires may spin or slide. With the Vehicle Dynamic Control (VDC) system, sensors detect these movements and control the braking and engine output to help improve vehicle stability.

- When the VDC system is operating, the “SLIP” indicator in the instrument panel blinks.
- When only the Traction Control System (TCS) portion of the VDC system is operating, the “SLIP” indicator in the instrument panel blinks.
- If the “SLIP” indicator blinks, the road conditions are slippery. Be sure to adjust your speed and driving to these conditions. Be sure to drive carefully. See “Slip indicator light”, and “Vehicle Dynamic Control (VDC) off indicator light” in the “2. Instruments and controls” section.
- Indicator light
If a malfunction occurs in the system, the “SLIP” and “VDC OFF” indicator lights illuminate in the instrument panel. As long as these indicators are illuminated, the VDC system function is canceled.

The VDC system uses an Active Brake Limited Slip (ABLS) system to improve vehicle traction. The ABLS system works when one of the driving wheels is spinning on a slippery surface. The ABLS system brakes the spinning wheel which distributes the driving power to the other driving wheel. If the vehicle is operated with the VDC system turned off, all VDC system functions and TCS functions will be turned off. The ABLS system and ABS will still operate with the VDC system off. When the ABLS system is activated, the “SLIP” indicator light will blink and you may hear a clunk noise and/or feel a pulsation in the brake pedal. This is normal and is not an indication of a malfunction.

While the VDC system is operating, you may feel a pulsation in the brake pedal and hear a noise or feel a vibration from under the hood. This is normal and indicates that the VDC system is working properly.

The VDC system computer has a built in diagnostic feature that tests the system each time you start the engine and move the vehicle forward or backward. When the self-test occurs, you may hear a clunk noise and/or feel a pulsation in the brake pedal. This is normal and is not an indication of a malfunction.



WARNING

- The VDC system is designed to help improve driving stability but does not prevent accidents due to abrupt steering operation at high speeds or due to careless or dangerous driving. Reduce vehicle speed and be especially careful when driving and cornering on slippery surfaces and always drive carefully.
- If engine related parts such as muffler are not standard equipment or are extremely deteriorated, the “VDC OFF” indicator or “SLIP” indicator or both indicator lights may illuminate.
- Do not modify the vehicle’s suspension. If suspension parts such as shock absorbers, struts, springs, stabilizer bars and bushings are not INFINITI-approved or are extremely deteriorated, the VDC system may not operate properly. This could adversely affect vehicle handling performance, and the “VDC OFF” indicator or “SLIP” indicator or both indicator lights may illuminate.

- If brake related parts such as brake pads, rotors and calipers are not standard equipment or are extremely deteriorated, the “VDC OFF” indicator or “SLIP” indicator or both indicator lights may illuminate.
- When driving on extremely inclined surfaces such as higher banked corners, the Vehicle Dynamic Control system may not operate properly and the “VDC OFF” indicator or “SLIP” indicator or both indicator lights may illuminate. Do not drive on these types of roads.
- When driving on an unstable surface such as a turntable, ferry, elevator or ramp, the “VDC OFF” indicator or “SLIP” indicator or both indicator lights may illuminate. This is not a malfunction. Restart the engine after driving onto a stable surface.
- If wheels or tires other than those recommended are used, the VDC system may not operate properly and the “VDC OFF” indicator or “SLIP” indicator or both indicator lights may illuminate.

- The VDC system is not a substitute for winter tires or tire chains on a snow covered road.

REAR ACTIVE STEER (RAS) SYSTEM (if so equipped)

The Rear Active Steer (RAS) system is an electronically controlled four-wheel steering system.

The angle of the rear wheels are adjusted by the RAS system, depending on the vehicle speed and steering angle. The rear wheels are designed to turn momentarily in the opposite direction and then change to the same direction as the front wheels.

At low speeds, the rear wheels will not turn and the system functions as a two-wheel steering system.

If a malfunction occurs in the system, the RAS function will stop but the ordinary two-wheel steering system will operate normally. The “RAS” warning light will illuminate.

If the light illuminates while you are driving, contact an INFINITI dealer for repair.



WARNING

The RAS system, although a sophisticated device, cannot prevent accidents resulting from careless or dangerous driving techniques. Ultimately the responsibility for safety of self and others rests in the hands of the driver. Therefore only through attentive and careful driving methods can the RAS system be fully appreciated and safety assured.

COLD WEATHER DRIVING

FREEING A FROZEN DOOR LOCK

To prevent a door lock from freezing, apply de-icer or glycerin to it through the key hole. If the lock becomes frozen, heat the key before inserting it into the key hole.

ANTI-FREEZE

In the winter when it is anticipated that the temperature will drop below 32°F (0°C), check antifreeze to assure proper winter protection. For additional information, see “Engine cooling system” in the “8. Maintenance and do-it-yourself” section.

BATTERY

If the battery is not fully charged during extremely cold weather conditions, the battery fluid may freeze and damage the battery. To maintain maximum efficiency, the battery should be checked regularly. For additional information, see “Battery” in the “8. Maintenance and do-it-yourself” section.

DRAINING OF COOLANT WATER

If the vehicle is to be left outside without antifreeze, drain the cooling system by opening the drain plug located under the radiator. Refill before operating the vehicle. See “Engine cooling system” in the

“8. Maintenance and do-it-yourself” section for changing engine coolant.

TIRE EQUIPMENT

1. SUMMER tires are of a tread design to provide superior performance on dry pavement. However, the performance of these tires will be substantially reduced in snowy and icy conditions. If you operate your vehicle on snowy or icy roads, INFINITI recommends the use of MUD & SNOW or ALL SEASON tires on all four wheels. Please consult an INFINITI dealer for the tire type, size, speed rating and availability information.
2. For additional traction on icy roads, studded tires may be used. However, some provinces and states prohibit their use. Check local, state and provincial laws before installing studded tires.

Skid and traction capabilities of studded snow tires, on wet or dry surfaces, may be poorer than that of non-studded snow tires.

3. Tire chains may be used if desired. Make sure they are of proper size for the tires on your vehicle and are in-

stalled according to the chain manufacturer's suggestions. However, some provinces and states prohibit their use. Check local state and provincial laws before installing tire chains. **Use only SAE Class S chains.** Class "S" chains are used on vehicles with restricted tire to vehicle clearance. Vehicles that can use Class "S" chains are designed to meet the SAE standard minimum clearances between the tire and the closest vehicle suspension or body component required to accommodate the use of a winter traction device (tire chains or cables). The minimum clearances are determined using the factory equipped tire size. Other types may damage your vehicle. Use chain tensioners when recommended by the tire chain manufacturer to ensure a tight fit. Loose end links of the tire chain must be secured or removed to prevent the possibility of damage to the fenders or underbody. If possible, avoid fully loading your vehicle when using tire chains. In addition, drive at a reduced speed. Otherwise, your vehicle may be damaged and/or vehicle handling and performance may be adversely affected.

- **Never install the tire chains on TEMPORARY USE ONLY spare tires.**
- **Do not use the tire chains on dry roads.**
- **The tire chains must be installed only on the rear wheels and not on the front wheels.**

Do not drive with tire chains on paved roads which are clear of snow. Driving with chains in such conditions can cause damage to the various mechanisms of the vehicle due to some over-stress.

4. For all-wheel drive (AWD):
If you install snow tires, they must also be the same size, brand, construction and tread pattern on all four wheels.

SPECIAL WINTER EQUIPMENT

It is recommended that the following items be carried in the vehicle during winter:

- a scraper and stiff-bristled brush to remove ice and snow from the windows and wiper blades.
- a sturdy, flat board to be placed under the jack to give it firm support.

- a shovel to dig the vehicle out of snow-drifts.
- extra window washer fluid to refill the reservoir tank.

DRIVING ON SNOW OR ICE



WARNING

- **Wet ice (32°F, 0°C and freezing rain), very cold snow or ice can be slick and very hard to drive on. The vehicle will have much less traction or "grip" under these conditions. Try to avoid driving on wet ice until the road is salted or sanded.**
- **Whatever the condition, drive with caution. Accelerate and slow down with care. If accelerating or downshifting too fast, the drive wheels will lose even more traction.**
- **Allow more stopping distance under these conditions. Braking should be started sooner than on dry pavement.**

- Allow greater following distances on slippery roads.
- Watch for slippery spots (glare ice). These may appear on an otherwise clear road in shaded areas. If a patch of ice is seen ahead, brake before reaching it. Try not to brake while on the ice, and avoid any sudden steering maneuvers.
- Do not use cruise control on slippery roads.
- Snow can trap dangerous exhaust gases under your vehicle. Keep snow clear of the exhaust pipe and from around your vehicle.



WARNING

Do not use your heater with an ungrounded electrical system or tow-pronged (cheater) adapters. You can be injured by an electrical shock if you use an ungrounded connection.

ENGINE BLOCK HEATER (if so equipped)

An engine block heater to assist extreme cold temperature starting is available through an INFINITI dealer.

6 In case of emergency

Roadside assistance program	6-2	If your vehicle overheats	6-11
Flat tire	6-2	Towing your vehicle	6-12
Tire pressure monitoring system (TPMS)	6-2	Towing recommended by INFINITI	6-12
Changing a flat tire	6-2	Vehicle recovery (Freeing a stuck	
Jump starting	6-8	vehicle)	6-15
Push starting	6-10		



ROADSIDE ASSISTANCE PROGRAM

Every new INFINITI comes with a 4 year, unlimited mileage Roadside Assistance plan. In the event of a roadside emergency, Roadside Assistance Service is available to you. Please refer to your Warranty Booklet (U.S.) or Warranty & Roadside assistance information booklet (Canada) for details. Both the Warranty Booklet and Roadside Assistance Calling Card in your Owner's Literature Portfolio provide the Toll-Free Number to call for assistance. Roadside Assistance is provided 24 hours a day, 365 days a year, for 4 years from the date sold to give emergency roadside help, in the event of mechanical or nonmechanical trouble(s) such as flat tires, out-of-gas, dead battery, lost keys, mechanical breakdown, accident, etc.

6-2 In case of emergency

FLAT TIRE

TIRE PRESSURE MONITORING SYSTEM (TPMS)

This vehicle is equipped with the tire pressure monitoring system (TPMS). It monitors tire pressure of all tires except the spare. When the low tire pressure warning light is lit, or flashing continuously one or more of your tires is significantly under-inflated. If the vehicle is being driven with low tire pressure, the TPMS will activate and warn you of it by the low tire pressure warning light. This system will activate only when the vehicle is driven at speeds above 16 MPH (25 km/h). For more details, refer to "Warning/indicator lights and audible reminders" in the "2. Instruments and controls" section and "Tire pressure monitoring system (TPMS)" in the "5. Starting and driving" section.



WARNING

- If the low tire pressure warning light illuminates while driving, avoid sudden steering maneuvers or abrupt braking, reduce vehicle speed, pull off the road to a safe location and stop the vehicle as soon as possible. Serious vehicle

damage could occur and may lead to an accident and could result in serious personal injury. Check the tire pressure for all four tires. Adjust the tire pressure to the recommended COLD tire pressure shown on the Tire and Loading Information label to turn the low tire pressure warning light OFF. If you have a flat tire, replace it with a spare tire as soon as possible.

- When a spare tire is mounted or a wheel is replaced, tire pressure will not be indicated, the TPMS will not function and the low tire pressure warning light will flash. Contact your INFINITI dealer as soon as possible for tire replacement and/or system resetting.
- Replacing tires with those not originally specified by INFINITI could affect the proper operation of the TPMS.
- Do not inject any tire liquid or aerosol tire sealant into the tires, as this may cause a malfunction of the tire pressure sensors.

CHANGING A FLAT TIRE

If you have a flat tire, follow the instructions below.

Stopping the vehicle

1. Safely move the vehicle off the road away from traffic.
2. Turn on the hazard warning flashers.
3. Park on a level surface and apply the parking brake. Shift the manual transmission into the R (Reverse) position (automatic transmission into the P (Park) position).
4. Turn off the engine.
5. Raise the hood to warn other traffic, and to signal professional road assistance personnel that you need assistance.
6. Have all passengers get out of the vehicle and stand in a safe place, away from traffic and clear of the vehicle.



WARNING

- Make sure the parking brake is securely applied and the manual transmission is shifted into R (Reverse), or the automatic transmission into P (Park).

- Never change tires when the vehicle is on a slope, ice or slippery areas. This is hazardous.
- Never change tires if oncoming traffic is close to your vehicle. Wait for professional road assistance.

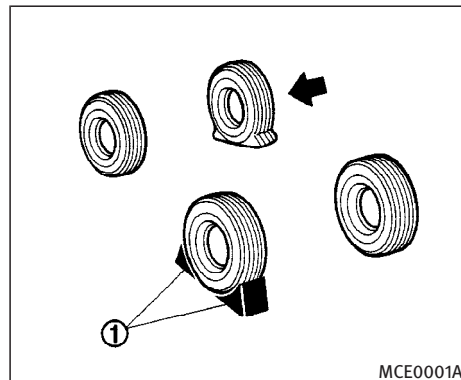

Blocking wheels

Place suitable blocks ① at both the front and back of the wheel diagonally opposite the flat tire to prevent the vehicle from moving when it is jacked up.



WARNING

Be sure to block the wheel as the vehicle may move and result in personal injury.

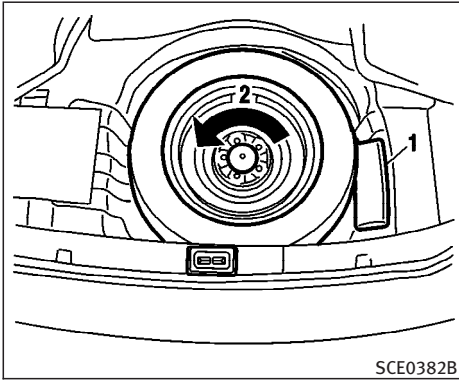

SCE0382B

Sedan — Type A

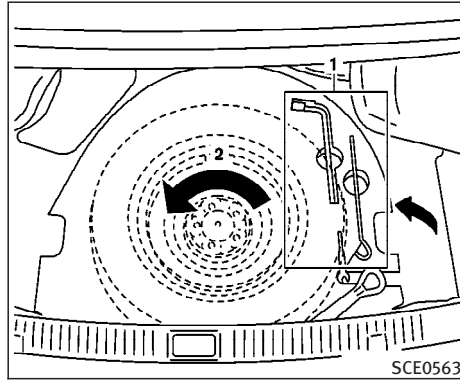

SCE0563

Sedan — Type B

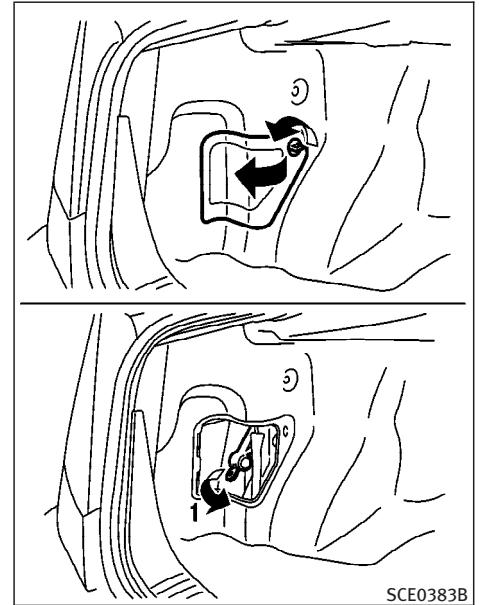

SCE0383B

Sedan

Getting the spare tire and tools

Remove jacking tools 1 and spare tire 2 from the storage area located inside the trunk as illustrated.

If spacers are equipped, remove them before removing the spare tire.

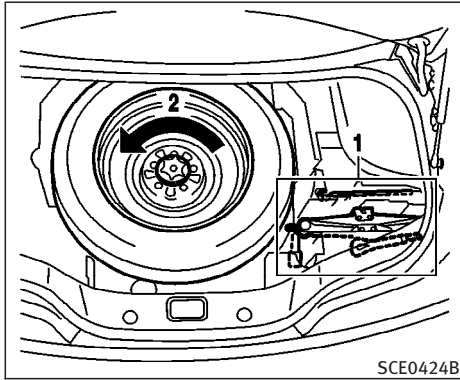

Coupe

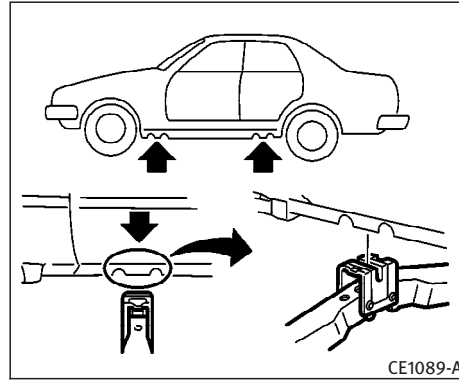

Jack-up point

Jacking up the vehicle and removing the damaged tire

Carefully read the caution label attached to the jack body and the following instructions.

1. Place the jack directly under the jack-up point as illustrated above so that top of the jack contacts the vehicle at the jack-up point. Align the jack head between the two notches in the front or the rear as shown. Also fit the groove of the jack head between the notches as shown.

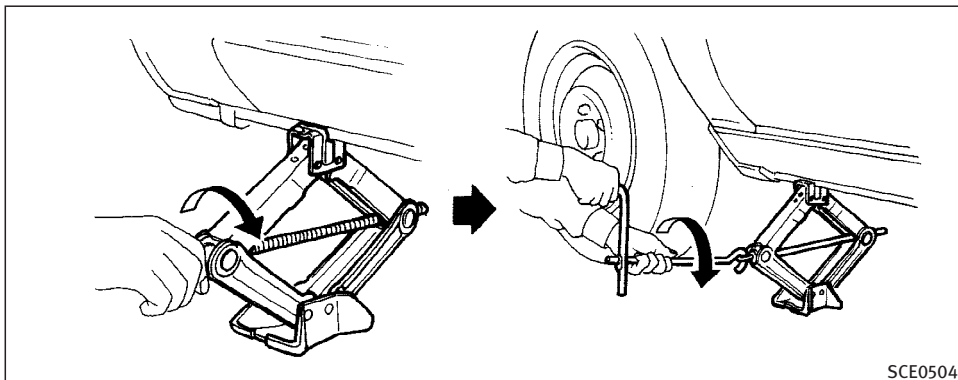

The jack should be used on level firm ground.

2. Loosen each wheel nut one or two turns by turning counterclockwise with the wheel nut wrench. **Do not remove the wheel nuts until the tire is off the ground.**
3. Carefully raise the vehicle until the tire clears the ground. To lift the vehicle, securely hold the jack lever and rod with both hands as shown above. Remove the wheel nuts, and then remove the tire.



WARNING

- Never get under the vehicle while it is supported only by the jack. If it is necessary to work under the vehicle, support it with safety stands.
- Use only the jack provided with your vehicle to lift the vehicle. Do not use the jack provided with your vehicle on other vehicles. The jack is designed for lifting only your vehicle during a tire change.

- Never use any other part of the vehicle for jack support.
- Never jack up the vehicle more than necessary.
- Never use blocks on or under the jack.
- Do not start or run the engine while vehicle is on the jack. This is especially true for vehicles with limited slip differentials.
- Do not allow passengers to stay in the vehicle while it is on the jack.

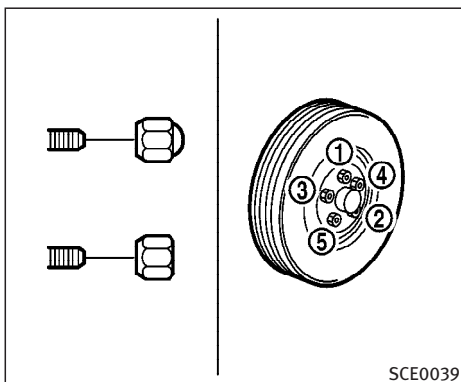

Installing the spare tire

The spare tire is designed emergency use. See specific instructions under the heading “Wheels and tires” in the “8. Maintenance and do-it-yourself” section.

1. Clean any mud or dirt from the surface between the wheel and hub.
2. Carefully put the wheel on and tighten the wheel nuts finger tight.

(Coupe models)

When replacing a front tire, make sure the hole in the spare tire wheel is

aligned with the pin on the brake rotor.

3. With the wheel nut wrench, tighten wheel nuts alternately and evenly until they are tight.
4. Lower the vehicle slowly until the tire touches the ground. Then, with the wheel nut wrench, tighten the wheel nuts securely in the sequence illustrated (1, 2, 3, 4, 5). Lower the vehicle completely.



WARNING

- Incorrect wheel nuts or improperly tightened wheel nuts can cause the wheel to become loose or come off. This could cause an accident.
- Do not use oil or grease on the wheel studs or nuts. This could cause the nuts to become loose.
- Retighten the wheel nuts after the vehicle has been driven for 600 miles (1,000 km) (also in cases of a flat tire, etc.).

As soon as possible tighten the wheel nuts to the specified torque with a torque wrench.

Wheel nut tightening torque:

80 ft-lb (108 N-m)

The wheel nuts must be kept tightened to specification at all times. It is recommended that wheel nuts be tightened to specification at each lubrication interval.

Adjust the tire pressure to the COLD pressure.

COLD pressure:

After the vehicle has been parked for three hours or more or driven less than 1 mile (1.6 km) at moderate speeds.

COLD tire pressures are shown on the Tire and Loading Information label affixed to the driver side center pillar.

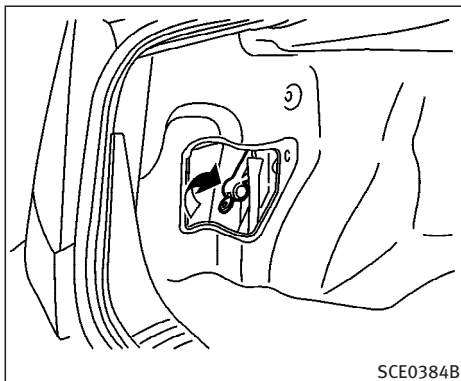

Sedan

5. Securely store the flat tire and jacking equipment in the vehicle.
6. Place the spare tire cover and the trunk floor carpeting over the damaged tire.
7. Close the trunk.



WARNING

- Always make sure that the spare tire and jacking equipment are properly secured after use. Such items can become

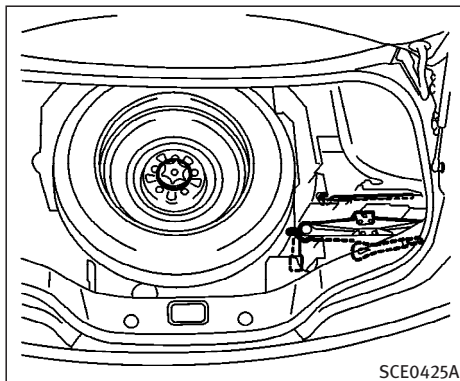

Coupe

dangerous projectiles in an accident or sudden stop.

- The T-type spare tire and small size spare tire are designed for emergency use. See “Wheels and tires” in the “8. Maintenance and do-it-yourself” section.

If needed, Roadside Assistance is available. Please see your Warranty Information Booklet or Roadside Assistance I.D. Card for the toll-free number to call (U.S.) or Warranty Information Booklet (Canada).

JUMP STARTING

To start your engine with a booster battery, the instructions and precautions below must be followed.



WARNING

- If done incorrectly, jump starting can lead to a battery explosion, resulting in severe injury or death. It could also damage your vehicle.
- Explosive hydrogen gas is always present in the vicinity of the battery. Keep all sparks and flames away from the battery.
- Do not allow battery fluid to come into contact with eyes, skin, clothing or painted surfaces. Battery fluid is a corrosive sulfuric acid solution which can cause severe burns. If the fluid should come into contact with anything, immediately flush the contacted area with water.
- Keep battery out of the reach of children.

- The booster battery must be rated at 12 volts. Use of an improperly rated battery can damage your vehicle.
- Whenever working on or near a battery, always wear suitable eye protectors (for example, goggles or industrial safety spectacles) and remove rings, metal bands, or any other jewelry. Do not lean over the battery when jump starting.
- Do not attempt to jump start a frozen battery. It could explode and cause serious injury.

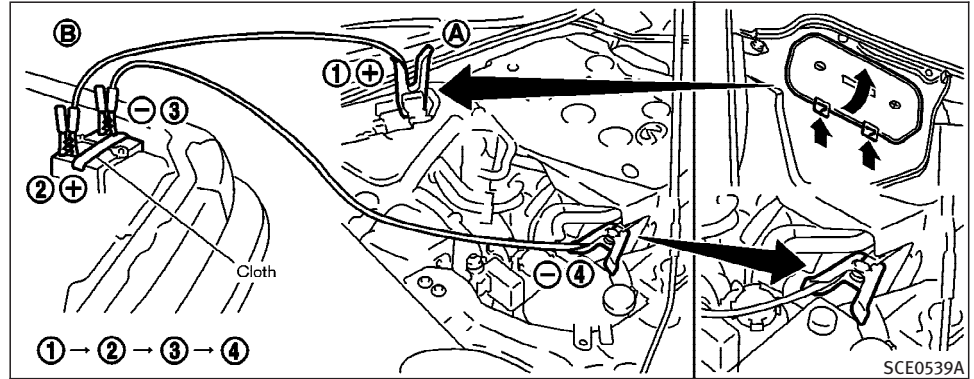

WARNING

Always follow the instructions below. Failure to do so could result in damage to the charging system and cause personal injury.

1. If the booster battery is in another vehicle (B), position the two vehicles (A) and (B) to bring their batteries into close proximity to each other.

Do not allow the two vehicles to touch.

2. Apply parking brake. Move the shift lever to the N (Neutral) position. (On automatic transmission models, move the selector lever to the P (Park) position). Switch off all unnecessary electrical systems (light, heater, air conditioner, etc.).
3. Remove vent caps on the battery (if so equipped). Cover the battery with an old cloth to reduce explosion hazard.
4. Connect jumper cables in the sequence as illustrated.



CAUTION

- Always connect positive (+) to positive (+) and negative (-) to body ground, not to the battery.
 - Make sure jumper cables do not touch moving parts in the engine compartment and that the cable clamps do not contact any other metal.
5. Start the engine of the other vehicle **(B)** and let it run for a few minutes.
 6. Keep the engine speed of the other vehicle **(B)** at about 2,000 rpm, and start your engine in the normal manner.



CAUTION

Do not keep the starter motor engaged for more than 10 seconds. If the engine does not start right away, turn the key off and wait 3 to 4 seconds before trying again.

7. After starting your engine, carefully disconnect the negative cable and then the positive cable.
8. Replace the vent caps (if so equipped). Be sure to dispose of the cloth used to cover the vent holes as it may be contaminated with corrosive acid.

PUSH STARTING

Do not attempt to start the engine by pushing.



CAUTION

Automatic transmission models cannot be push started. Attempting to do so may cause transmission damage.

If needed Roadside Assistance is available. Please see your Warranty Information Booklet or Roadside Assistance I.D. Card for the toll-free number to call (U.S.) or Warranty Information Booklet (Canada).

IF YOUR VEHICLE OVERHEATS



WARNING

- Do not continue to drive if your vehicle overheats. Doing so could cause engine damage or a vehicle fire.
- To avoid the danger of being scalded, never remove the radiator cap while the engine is still hot. When the radiator cap is removed, pressurized hot water will spurt out, possibly causing serious injury.
- Do not open the hood if steam is coming out.

If your vehicle is overheating (indicated by an extremely high temperature gauge reading), or if you feel a lack of engine power, detect abnormal noise, etc., take the following steps:

1. Move the vehicle safely off the road, apply the parking brake and move the shift lever to the N (Neutral) position (automatic transmission to the P (Park) position).

Do not stop the engine.

2. Turn off the air conditioner. Open all the windows, and move the temperature control to maximum hot and the fan control to high speed.
3. If engine overheating is caused by climbing a long hill on a hot day, run the engine at a fast idle (approximately 1,500 rpm) until the temperature gauge indication returns to normal.
4. Get out of the vehicle. Look and listen for steam or coolant escaping from the radiator before opening the hood. (If steam or coolant is escaping, turn off the engine.) Do not open the hood further until no steam or coolant can be seen.
5. Open the engine hood.



WARNING

If steam or water is coming from the engine, stand clear to prevent getting burned.

6. Visually check if the cooling fan is running. The radiator hoses and radiator should not leak water. If coolant is leaking or the cooling fan does not run, stop the engine.



WARNING

- Be careful not to allow your hands, hair, jewelry or clothing to come into contact with, or to get caught in, the engine belts or the engine cooling fan.
 - The engine cooling fan can start at any time when the coolant temperature is high.
7. After the engine cools down, check the coolant level in the reservoir tank with the engine running. Add coolant to the reservoir tank if necessary. Have your vehicle repaired at an INFINITI dealer.

If needed, Roadside Assistance is available. Please see your Warranty Information Booklet or Roadside Assistance I.D. Card for the toll-free number to call (U.S.) or Warranty Information Booklet (Canada).

TOWING YOUR VEHICLE

When towing your vehicle, all State (Provincial in Canada) and local regulations for towing must be followed. Incorrect towing equipment could damage your vehicle. Towing instructions are available from an INFINITI dealer. Local service operators are generally familiar with the applicable laws and procedures for towing. To assure proper towing and to prevent accidental damage to your vehicle, INFINITI recommends having a service operator tow your vehicle. It is advisable to have the service operator carefully read the following precautions.



WARNING

- Never ride in a vehicle that is being towed.
- Never get under your vehicle after it has been lifted by a tow truck.



CAUTION

- When towing, make sure that the transmission, axles, steering system and

powertrain are in working condition. If any unit is damaged, dollies must be used.

- Always attach safety chains before towing.

For information about towing your vehicle behind a recreational vehicle (RV), refer to “Flat towing” in the “9. Technical and consumer information” section of this manual.

If needed, Roadside Assistance is available. Please see your Warranty Information Booklet or Roadside Assistance I.D. Card for the toll-free number to call (U.S.) or Warranty Information Booklet (Canada).

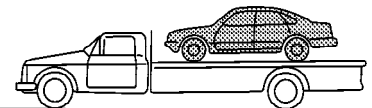
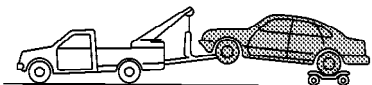

SCE0386

**Two-wheel drive (2WD) models
TOWING RECOMMENDED BY
INFINITI**

Two-wheel drive (2WD) models
INFINITI recommends that your vehicle be
towed with the driving (rear) wheels off

the ground or place the vehicle on a flat bed truck as illustrated.

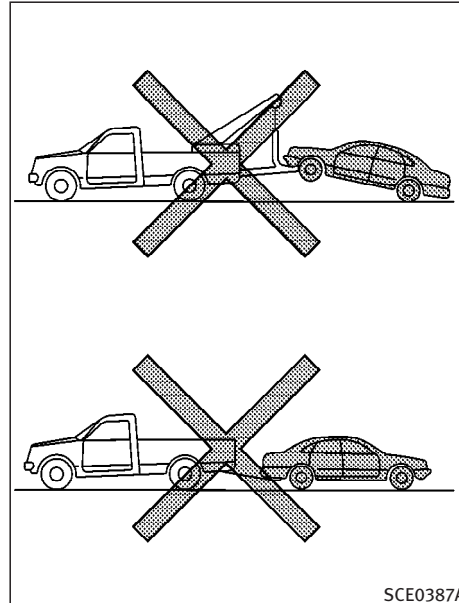

Automatic transmission (AT) models



CAUTION

- Never tow automatic transmission models with the rear wheels on the

ground or four wheels on the ground (forward or backward) as this may cause serious and expensive damage to the transmission. If it is necessary to tow the vehicle with the front wheels raised, always use towing dollies under the rear wheels.

- When towing rear wheel drive models with the front wheels on the ground or on towing dollies:

Turn the ignition key to the OFF position, and secure the steering wheel in a straight ahead position with a rope or similar device. Never secure the steering wheel by turning the ignition key to the LOCK position. This may damage the steering lock mechanism.

- If you have to tow manual transmission models with the rear wheels on the ground or four wheels on the ground (if you do not use towing dollies):

- Always release the parking brake.
- Move the transmission shift lever to the N (Neutral) position.

- **Observe the following restricted towing speeds and distances for manual transmission models only:**

- **Speed: Below 60 MPH (95 km/h)**
- **Distance: Less than 500 miles (800 km)**

If the speed or distance must necessarily be greater, remove the propeller shaft before towing to prevent damage to the transmission.

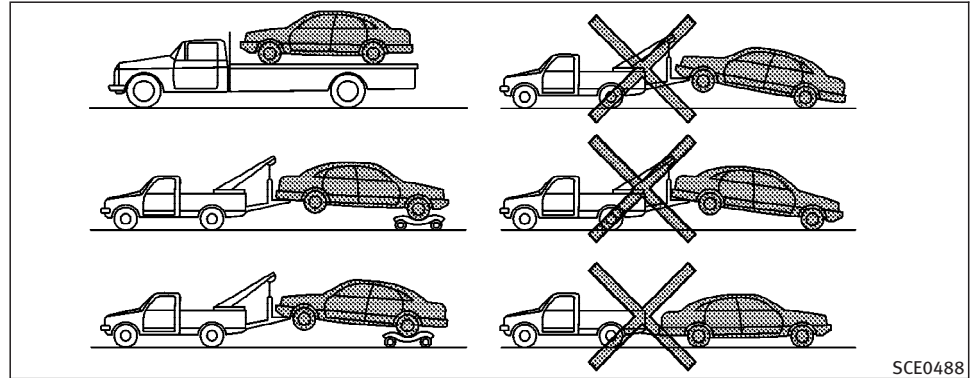

SCE0488

All-wheel drive (AWD) models

INFINITI recommends that towing dollies be used when towing your vehicle, or the vehicle be placed on a flat bed truck as illustrated.



CAUTION

Never tow AWD models with any of the wheels on the ground as this may cause serious and expensive damage to the power train.

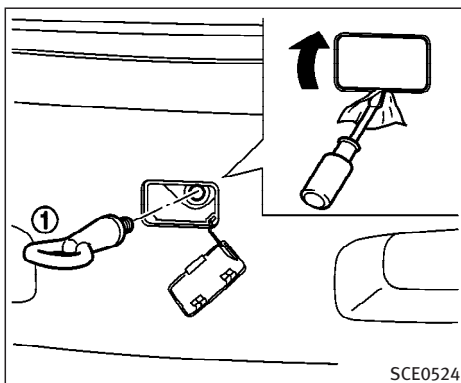

VEHICLE RECOVERY (Freeing a stuck vehicle)

After removing the front license plate (or the bumper cover), securely install the recovery hook ①. (Located with jacking tools.)

Reinstall the license plate on the lower fitting point.

WARNING

- Stand clear of a stuck vehicle.
- Do not spin your tires at high speed. This could cause them to explode and result in serious injury. Parts of your vehicle could also overheat and be damaged.

CAUTION

- Tow chains or cables must be attached only to the vehicle recovery hooks or main structural members of the vehicle. Otherwise, the vehicle body will be damaged.
- Do not use the vehicle tie downs to free a vehicle stuck in sand, snow, mud, etc. Never tow a vehicle using the vehicle tie downs or recovery hooks.
- Always pull the cable straight out from the front of the vehicle. Never pull the vehicle at an angle.

- Pulling devices should be routed so they do not touch any part of the suspension, steering, brake or cooling systems.
- Pulling devices such as ropes or canvas straps are not recommended for use in vehicle towing or recovery.

If your vehicle is stuck in sand, snow, mud, etc., use the following procedure:

1. Turn off the Vehicle Dynamic Control (VDC) system.
 2. Make sure the area in front and behind the vehicle is clear of obstructions.
 3. Turn the steering wheel right and left to clear an area around the front tires.
 4. Slowly rock the vehicle forward and backward.
- Shift back and forth between R (reverse) and D (drive) (automatic transmission models) or 1st (low) and R (reverse) (manual transmission models).
 - Apply the accelerator as little as possible to maintain the rocking motion.

- Release the accelerator pedal before shifting between R and D (automatic transmission models) or 1st and R (manual transmission models).
 - Do not spin the tires above 35 MPH (55 km/h).
5. If the vehicle cannot be freed after a few tries, contact a professional towing service to remove the vehicle.

7 Appearance and care

Cleaning exterior	7-2	Cleaning interior	7-4
Washing	7-2	Floor mats	7-4
Waxing	7-2	Seat belts	7-5
Removing spots	7-3	Corrosion protection	7-5
Underbody	7-3	Most common factors contributing to	
Glass	7-3	vehicle corrosion	7-5
Aluminum alloy wheels	7-3	Environmental factors influence the rate of	
Chrome parts	7-3	corrosion	7-5
Tire dressing	7-3	To protect your vehicle from corrosion	7-5

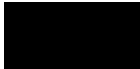

CLEANING EXTERIOR

In order to maintain the appearance of your vehicle, it is important to care for it properly.

To protect the paint surfaces, please wash your vehicle as soon as you can.

- After a rainfall to prevent possible damage from acid rain.
- After driving in coastal areas to prevent possible damage from sea salt.
- When foreign objects, such as soot, bird droppings, tree sap, metal particles, or insects get on the paint surfaces.
- When dust or mud builds up on the paint surfaces.

Whenever possible, store or park your vehicle inside garage or in covered area.

When it is necessary to park outside, park in a shady area or protect the vehicle with a body cover.

Be careful not to scratch the paint surface when putting on or removing the body cover.

WASHING

Wash dirt off the vehicle with a wet sponge and plenty of water. Clean the ve-

7-2 Appearance and care

hicle thoroughly using a mild soap, special vehicle soap or general purpose dish-washing liquid mixed with clean, luke-warm (never hot) water.



CAUTION

- **Do not use strong household soap, strong chemical detergents, gasoline or solvents.**
- **Do not wash the vehicle in direct sunlight or while the vehicle body is hot, as the surface may become water-spotted.**
- **Avoid using tight-napped or rough cloths, such as washing mitts. Care must be taken when removing caked-on dirt or other foreign substances so the paint surface is not scratched or damaged.**

Rinse the vehicle again with plenty of clean water.

Inside flanges, seams and folds on the doors, hatches and hood are particularly vulnerable to the effects of road salt. Therefore, these areas must be regularly cleaned. Make sure that the drain holes in the lower edge of the door are open.

Spray water under the body and in the wheel wells to loosen the dirt and wash away road salt.

Avoid leaving water spots on the paint surface by using a damp chamois to dry the vehicle.

WAXING

Regular waxing protects the paint surface and helps retain new vehicle appearance. Polishing is recommended to remove built-up wax residue and to avoid a weathered appearance before re-applying wax.

An INFINITI dealer can assist you in choosing the proper product.

- Wax your vehicle only after a thorough washing. Follow the instructions supplied with the wax.
- Do not use a wax containing any abrasives, cutting compounds or cleaners that may damage the vehicle finish.

Machine compounding or aggressive polishing on a base coat/clear coat paint finish may dull the finish or leave swirl marks.

REMOVING SPOTS

Remove tar and oil spots, industrial dust, insects, and tree sap as quickly as possible from the surface of the paint to avoid lasting damage or staining. Special cleaning products are available at an INFINITI dealer or any automotive accessory store.

UNDERBODY

In areas where road salt is used in winter, the underbody must be cleaned regularly. This will prevent dirt and salt from building up and causing underbody and suspension corrosion. Before the winter period and again in the spring, the underseal must be checked and, if necessary, re-treated.

GLASS

Use glass cleaner to remove smoke and dust film from the glass surfaces. It is normal for glass to become coated with a film after the vehicle is parked in the hot sun. Glass cleaner and a soft cloth will easily remove this film.



CAUTION

When cleaning the inside of the windows, do not use sharp-edged tools, abrasive cleaners or chlorine-based disinfectant cleaners. They could damage the electrical conductors, radio antenna elements or rear window defroster elements.

ALUMINUM ALLOY WHEELS

Wash regularly, especially during winter months in areas where road salt is used. Salt could discolor the wheel if not removed.

CHROME PARTS

Clean all chrome parts regularly with a non-abrasive chrome polish to maintain the finish.

TIRE DRESSING

INFINITI does not recommend the use of tire dressings. Tire manufacturers apply a coating to the tires to help reduce discoloration of the rubber. If a tire dressing is applied to the tires, it may react with the coating and form a compound. This com-

pound may come off the tire while driving and stain the vehicle paint.

If you choose to use a tire dressing, take the following precautions:

- Use a water-based tire dressing. The coating on the tire dissolves more easily with an oil-based tire dressing.
- Apply a light coat of tire dressing to help prevent it from entering the tire tread/grooves (where it would be difficult to remove).
- Wipe off excess tire dressing using a dry towel. Make sure the tire dressing is completely removed from the tire tread/grooves.
- Allow the tire dressing to dry as recommended by tire dressing manufacturer.

CLEANING INTERIOR

Occasionally remove loose dust from the interior trim, plastic parts and seats using a vacuum cleaner or soft bristled brush. Wipe the vinyl and leather surfaces with a clean, soft cloth dampened in mild soap solution, then wipe clean with a dry soft bristled cloth.

Regular care and cleaning is required in order to maintain the appearance of the leather.

Before using any fabric protector, read the manufacturer's recommendations. Some fabric protectors contain chemicals that may stain or bleach the seat material.

Use a cloth dampened only with water, to clean the meter and gauge lens.



CAUTION

- Never use gasoline, thinner, or any similar material.

- Small dirt particles can be abrasive and damaging to leather surfaces and should be removed promptly. Do not use saddle soap, car waxes, polishes, oils, cleaning fluids, solvents, detergents or ammonia-based cleaners as they may damage the leather's natural finish.
- Never use fabric protectors unless recommended by the manufacturer.
- Do not use glass or plastic cleaner on meter or gauge lens covers. It may damage the lens cover.

FLOOR MATS

The use of genuine INFINITI floor mats can extend the life of your vehicle carpet and make it easier to clean the interior. **No matter what mats are used, be sure they are fitted for your vehicle and are properly positioned in the footwell to prevent interference with pedal operation.** Mats should be maintained with regular cleaning and replaced if they become excessively worn.

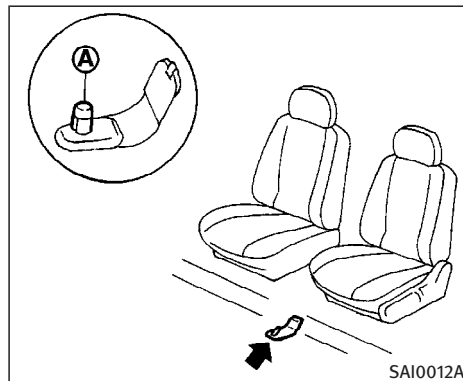

Floor mat positioning aid (driver's side only)

This model includes a front floor mat bracket (A) to act as a floor mat positioning aid. INFINITI floor mats have been specially designed for your vehicle model. The driver's side floor mat has a grommet hole incorporated in it. Simply position the mat by placing the floor mat bracket through the floor mat grommet hole while centering the mat in the floorpan contour.

Periodically check to make certain that the mats are properly positioned.

SEAT BELTS

The seat belts can be cleaned by wiping them with a sponge dampened in a mild soap solution. Allow the belts to dry completely before using them. See “Seat belt maintenance” in the “1. Safety — Seats, seat belts and supplemental restraint system” section.



WARNING

Do not allow wet seat belts to roll up in the retractor. NEVER use bleach, dye, or chemical solvents to clean the seat belts, since these materials may severely weaken the seat belt webbing.

CORROSION PROTECTION

MOST COMMON FACTORS CONTRIBUTING TO VEHICLE CORROSION

- The accumulation of moisture-retaining dirt and debris in body panel sections, cavities, and other areas.
- Damage to paint and other protective coatings caused by gravel and stone chips or minor traffic accidents.

ENVIRONMENTAL FACTORS INFLUENCE THE RATE OF CORROSION

Moisture

Accumulation of sand, dirt and water on the vehicle body underside can accelerate corrosion. Wet floor coverings will not dry completely inside the vehicle, and should be removed for drying to avoid floor panel corrosion.

Relative humidity

Corrosion will be accelerated in areas of high relative humidity, especially those areas where the temperatures stay above freezing and where atmospheric pollution exists and road salt is used.

Temperature

A temperature increase will accelerate the rate of corrosion to those parts which are not well ventilated.

Air pollution

Industrial pollution, the presence of salt in the air in coastal areas, or heavy road salt use will accelerate the corrosion process. Road salt will also accelerate the disintegration of paint surfaces.

TO PROTECT YOUR VEHICLE FROM CORROSION

- Wash and wax your vehicle often to keep it clean.
- Always check for minor damage to the paint and repair it as soon as possible.
- Keep drain holes at the bottom of the doors open to avoid water accumulation.
- Check the underbody for accumulation of sand, dirt or salt. If present, wash with water as soon as possible.



CAUTION

- **NEVER** remove dirt, sand or other debris from the passenger compartment by washing it out with a hose. Remove dirt with a vacuum cleaner or broom.
- Never allow water or other liquids to come in contact with electronic components inside the vehicle as this may damage them.

Chemicals used for road surface de-icing are extremely corrosive. They accelerate corrosion and deterioration of underbody components such as the exhaust system, fuel and brake lines, brake cables, floor pan and fenders.

In winter, the underbody must be cleaned periodically.

For additional protection against rust and corrosion, which may be required in some areas, consult an INFINITI dealer.

8 Maintenance and do-it-yourself

Maintenance requirements	8-2	Air cleaner.....	8-20
General maintenance.....	8-2	Windshield wiper blades.....	8-21
Explanation of general maintenance items	8-3	Cleaning	8-21
Maintenance precautions.....	8-5	Replacing	8-22
Engine compartment check locations.....	8-7	Parking brake and brake pedal.....	8-23
Engine cooling system	8-8	Checking parking brake.....	8-23
Checking engine coolant level.....	8-8	Checking brake pedal.....	8-23
Changing engine coolant.....	8-9	Brake booster	8-24
Engine oil	8-10	Fuses	8-25
Checking engine oil level.....	8-10	Engine compartment.....	8-25
Changing engine oil and filter	8-11	Passenger compartment.....	8-27
Automatic transmission fluid.....	8-13	Keyfob battery replacement.....	8-28
Power steering fluid.....	8-13	Keyfob (except Intelligent Key).....	8-28
Brake and clutch fluid.....	8-14	Intelligent Key.....	8-29
Brake fluid.....	8-14	Lights.....	8-31
Clutch fluid	8-15	Headlights.....	8-33
Window washer fluid.....	8-15	Exterior and interior lights.....	8-33
Battery.....	8-16	Wheels and tires	8-37
Jump starting.....	8-18	Tire pressure	8-37
Drive belts	8-19	Tire labeling	8-41
Spark plugs	8-19	Types of tires	8-43
Replacing spark plugs.....	8-20	Tire chains	8-44
		Changing wheels and tires.....	8-45

MAINTENANCE REQUIREMENTS

Your new INFINITI has been designed to have minimum maintenance requirements with longer service intervals to save you both time and money. However, some day-to-day and regular maintenance is essential to maintain your INFINITI's fine mechanical condition, as well as its emission and engine performance.

It is the owner's responsibility to make sure that the specified maintenance as well as the general maintenance are performed.

As the vehicle owner, you are the only one who can ensure that your vehicle receives the proper maintenance care. You are a vital link in the maintenance chain.

Scheduled maintenance:

For your convenience, both required and optional scheduled maintenance items are described and listed in your "INFINITI Service and Maintenance Guide". You must refer to that guide to ensure that necessary maintenance is performed on your INFINITI at regular intervals.

General maintenance:

General maintenance includes those items which should be checked during normal day-to-day operation. They are es-

8-2 Maintenance and do-it-yourself

sential for proper vehicle operation. It is your responsibility to perform these maintenance procedures regularly as prescribed.

Performing general maintenance checks requires minimal mechanical skill and only a few general automotive tools.

These checks or inspections can be done by you, a qualified technician, or, if you prefer, an INFINITI dealer.

Where to go for service:

If maintenance service is required or your vehicle appears to malfunction, have the systems checked and serviced by an INFINITI dealer.

INFINITI technicians are well-trained specialists and are kept up to date with the latest service information through technical bulletins, service tips, and in-dealership information systems. They are completely qualified to work on INFINITI vehicles **before** work begins.

You can be confident that an INFINITI dealer's service department performs the best job to meet the maintenance requirements on your vehicle — in a reliable and economic way.

GENERAL MAINTENANCE

During the normal day-to-day operation of the vehicle, general maintenance should be performed regularly as prescribed in this section. If you detect any unusual sounds, vibrations or smell, be sure to check for the cause or have an INFINITI dealer perform it promptly. In addition, you should notify an INFINITI dealer if you think the repairs are required.

When performing any checks or maintenance work, closely observe the "Maintenance precautions" later in this section.

EXPLANATION OF GENERAL MAINTENANCE ITEMS

Additional information on the following items with “*” is found later in this section.

Outside the vehicle

The maintenance items listed here should be performed from time to time, unless otherwise specified.

Doors and engine hood: Check that all doors and the engine hood operate properly. Also ensure that all latches lock securely. Lubricate hinges and latches if necessary. Make sure that the secondary latch keeps the hood from opening when the primary latch is released.

When driving in areas using road salt or other corrosive materials, check lubrication frequently.

Lights*: Clean the headlights on a regular basis. Make sure that the headlights, stop lights, tail lights, turn signal lights, and other lights are all operating properly and installed securely. Also check headlight aim.

Road wheel nuts (lug nuts): When checking the tires, make sure no wheel

nuts are missing, and check for any loose wheel nuts. Tighten if necessary.

Tires*: Check the pressure with a gauge often and always prior to long distance trips. If necessary, adjust the pressure in all tires, including the spare, to the specified pressure. Check carefully for damage, cuts or excessive wear.

Tire rotation*:

Sedan: The tires should be rotated every 7,500 miles (12,000 km) to minimize tire wear variation.

Coupe: The tires cannot be rotated.

Tire, wheel alignment and balance: If the vehicle should pull to either side while driving on a straight and level road, or if you detect uneven or abnormal tire wear, there may be a need for wheel alignment.

If the steering wheel or seat vibrates at normal highway speeds, wheel balancing may be needed.

- For additional information regarding tires, refer to “Important Tire Safety Information” (US) or “Tire Safety Information” (Canada) in the Warranty Information Booklet.

Windshield: Clean the windshield on a regular basis. Check the windshield at least every six months for cracks or other damage. Have a damaged windshield repaired by a qualified repair facility.

Windshield wiper blades*: Check for cracks or wear if they do not wipe properly.

Inside the vehicle

The maintenance items listed here should be checked on a regular basis, such as when performing periodic maintenance, cleaning the vehicle, etc.

Accelerator pedal: Check the pedal for smooth operation and make sure the pedal does not catch or require uneven effort. Keep the floor mat away from the pedal.

Automatic transmission P (Park) mechanism: On a fairly steep hill check that your vehicle is held securely with the selector lever in the P (Park) position without applying any brakes.

Brake pedal*: Check the pedal for smooth operation and make sure it has the proper distance under it when depressed fully. Check the brake booster function. Be sure to keep the floor mat away from the pedal.

Brakes: Check that the brakes do not pull the vehicle to one side when applied.

Parking brake*: Check that the pedal/lever has the proper travel and confirm that your vehicle is held securely on a fairly steep hill with only the parking brake applied.

Seats: Check seat position controls such as seat adjusters, seatback recliner, etc. to ensure they operate smoothly and that all latches lock securely in every position. Check that the head restraints move up and down smoothly and that the locks (if so equipped) hold securely in all latched positions.

Seat belts: Check that all parts of the seat belt system (For example, buckles, anchors, adjusters and retractors) operate properly and smoothly, and are installed securely. Check the belt webbing for cuts, fraying, wear or damage.

Steering wheel: Check for changes in the steering conditions, such as excessive free play, hard steering or strange noises.

Warning lights and chimes: Make sure that all warning lights and chimes are operating properly.

Windshield defroster: Check that the air comes out of the defroster outlets properly and in sufficient quantity when operating the heater or air conditioner.

Windshield wiper and washer*: Check that the wipers and washer operate properly and that the wipers do not streak.

Under the hood and the vehicle

The maintenance items listed here should be checked periodically (For example, each time you check the engine oil or refuel).

Battery*: Check the fluid level in each cell. It should be between the MAX and MIN lines. Vehicles operated in high temperatures or under severe conditions require frequent checks of the battery fluid level.

Brake and clutch fluid level*: Make sure that the brake and clutch fluid levels are between the MAX and MIN lines on the reservoir.

Engine coolant level*: Check the coolant level when the engine is cold.

Engine drive belts*: Make sure that no belt is frayed, worn, cracked or oily.

Engine oil level*: Check the level after parking the vehicle on a level location and turning off the engine. (Wait at least 10 minutes for the oil to drain back into the oil pan.)

Exhaust system: Make sure there are no loose supports, cracks or holes. If the sound of the exhaust seems unusual or

there is a smell of exhaust fumes, immediately locate the trouble and correct it. See “Precautions when starting and driving” in the “5. Starting and driving” section for exhaust gas (Carbon monoxide).

Fluid leaks: Check under the vehicle for fuel, oil, water or other fluid leaks after the vehicle has been parked for a while. Water dripping from the air conditioner after use is normal. If you should notice any leaks or if gasoline fumes are evident, check for the cause and have it corrected immediately.

Power steering fluid level* and lines: Check the level when the fluid is cold and the engine is turned off. Check the lines for proper attachment, leaks, cracks, etc.

Radiator and hoses: Check the front of the radiator and clean off any dirt, insects, leaves, etc., that may have accumulated. Make sure the hoses have no cracks, deformation, deterioration or loose connections.

Underbody: The underbody is frequently exposed to corrosive substances such as those used on icy roads or to control dust. It is very important to remove these substances, otherwise rust will form on

the floor pan, frame, fuel lines and around the exhaust system. At the end of winter, the underbody should be thoroughly flushed with plain water, being careful to clean those areas where mud and dirt may accumulate. For additional information, see “Cleaning exterior” in the “7. Appearance and care” section.

Windshield washer fluid*: Check that there is adequate fluid in the tank.

MAINTENANCE PRECAUTIONS

When performing any inspection or maintenance work on your vehicle, always take care to prevent serious accidental injury to yourself or damage to the vehicle. The following are general precautions which should be closely observed.



WARNING

- **Park the vehicle on a level surface, apply the parking brake securely and block the wheels to prevent the vehicle from moving. For a manual transmission, move the shift lever to N (Neutral) position. For an automatic transmission models, move the selector lever to P (Park).**
- **Be sure the ignition key is in the OFF or LOCK position when performing any parts replacement or repairs.**
- **If you must work with the engine running, keep your hands, clothing, hair and tools away from moving fans, belts and any other moving parts.**
- **It is advisable to secure or remove any loose clothing and remove any jewelry,**

such as rings, watches, etc. before working on your vehicle.

- Always wear eye protection whenever you work on your vehicle.
- If you must run the engine in an enclosed space such as a garage, be sure there is proper ventilation for exhaust gases to escape.
- Never get under the vehicle while it is supported only by a jack. If it is necessary to work under the vehicle, support it with safety stands.
- Keep smoking materials, flame and sparks away from the fuel tank and battery.
- On gasoline engine models with the Multiport Fuel Injection (MFI) System, the fuel filter or fuel lines should be serviced by an INFINITI dealer because the fuel lines are under high pressure even when the engine is off.



CAUTION

- Do not work under the hood while the engine is hot. Turn the engine off and wait until it cools down.
- Never connect or disconnect the battery or any transistorized component while the ignition switch is in the ON position.
- Never leave the engine or automatic transmission related component harness connector disconnected while the ignition switch is in the ON position.
- Avoid contact with used engine oil and coolant. Improperly disposed engine oil, engine coolant and/or other vehicle fluids can damage the environment. Always conform to local regulations for disposal of vehicle fluid.

This “8. Maintenance and do-it-yourself” section gives instructions regarding only those items which are relatively easy for an owner to perform.

A genuine INFINITI Service Manual is also available. See “Owner’s Manual/Service Manual order information” in the “9. Technical and consumer information” section.

You should be aware that incomplete or improper servicing may result in operating difficulties or excessive emissions, and could affect your warranty coverage. **If in doubt about any servicing, have it done by an INFINITI dealer.**

ENGINE COMPARTMENT CHECK LOCATIONS

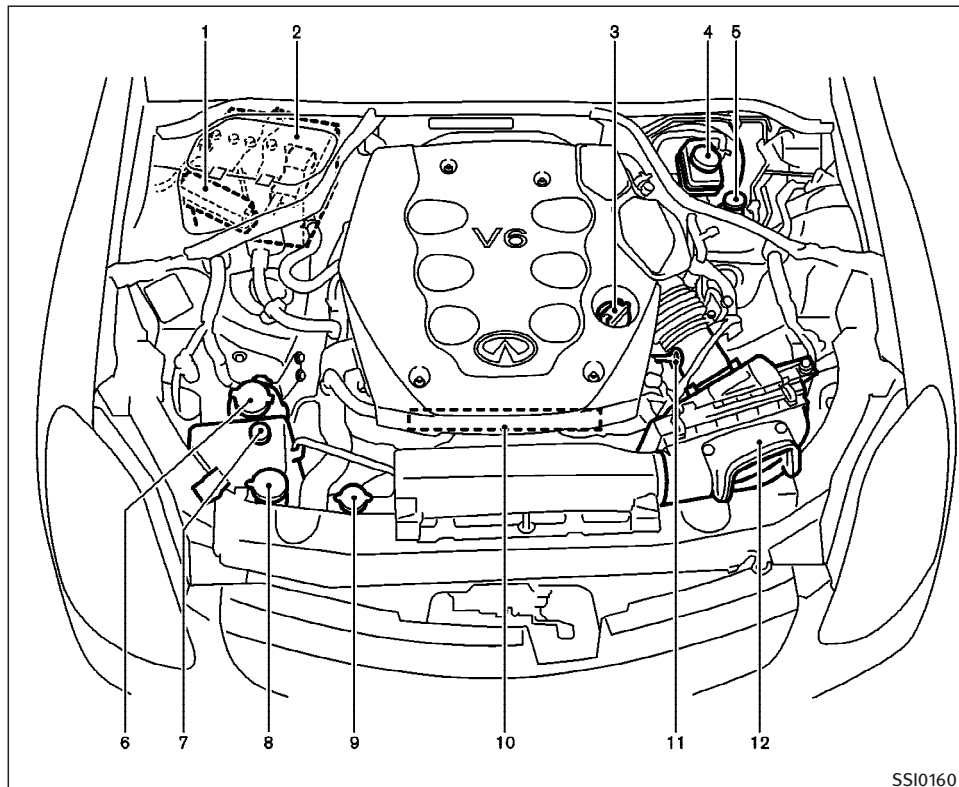

SSI0160

1. Fuse/fusible link holder
2. Battery
3. Engine oil filler cap
4. Brake fluid reservoir
5. Clutch fluid reservoir (MT models)
6. Power steering fluid reservoir
7. Engine coolant reservoir
8. Window washer fluid reservoir
9. Radiator filler cap
10. Drive belts
11. Engine oil dipstick
12. Air cleaner

ENGINE COOLING SYSTEM

The engine cooling system is filled at the factory with a high-quality, year-round, anti-freeze coolant solution. The anti-freeze solution contains rust and corrosion inhibitors, therefore additional cooling system additives are not necessary.

WARNING

- Never remove the radiator or coolant reservoir cap when the engine is hot. Wait until the engine and radiator cool down. Serious burns could be caused by high pressure fluid escaping from the radiator. See precautions in “If your vehicle overheats” found in the “6. In case of emergency” section.
- The radiator is equipped with a pressure type radiator cap. To prevent engine damage, use only a genuine NISSAN radiator cap.

CAUTION

When adding or replacing coolant, be sure to use only a Genuine Nissan Long Life Antifreeze/Coolant or equivalent with the proper mixture ratio of 50% antifreeze and 50% demineralized water/distilled water. The use of other types of engine coolant may damage your engine cooling system.

Outside temperature down to		Antifreeze	Demineralized water/ distilled water
°C	°F		
-35	-30	50%	50%

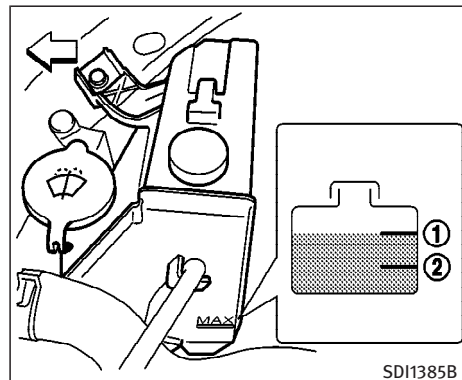

CHECKING ENGINE COOLANT LEVEL

Check the coolant level in the reservoir tank when the engine is cold. If the coolant level is below the MIN level ②, open the cap and add coolant up to the MAX level ①. If the reservoir tank is empty, check the coolant level in the radiator **when the engine is cold**. If there is insufficient coolant in the radiator, fill the radiator with coolant up to the filler opening and also add it to the reservoir tank up to the MAX level ①.

If the cooling system frequently requires coolant, have it checked by an INFINITI dealer.

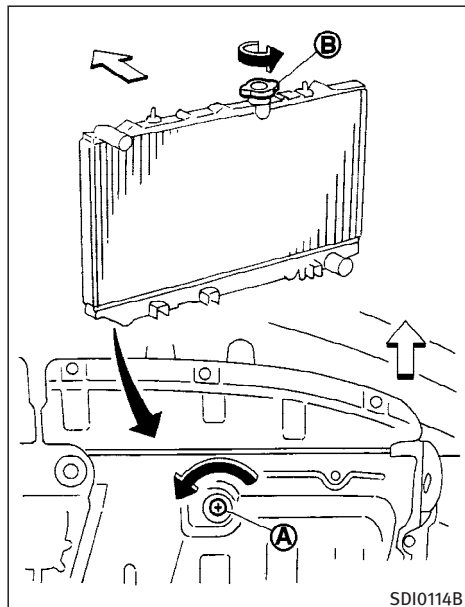

CHANGING ENGINE COOLANT

- Major cooling system repairs should be performed by an INFINITI dealer. The service procedures can be found in the appropriate INFINITI Service Manual.

- Improper servicing can result in reduced heater performance and engine overheating.



WARNING

- To avoid being scalded, never change the coolant when the engine is hot.
 - Never remove the radiator cap when the engine is hot. Serious burns could be caused by high pressure fluid escaping from the radiator.
 - Avoid direct skin contact with used coolant. If skin contact is made, wash thoroughly with soap or hand cleaner as soon as possible.
 - Keep coolant out of reach of children and pets.
1. Open radiator drain plug (A) at the bottom of radiator, and remove radiator filler cap (B).
- Be careful not to allow coolant to contact drive belts.
 - Waste coolant must be disposed of properly. Check your local regulations.

ENGINE OIL

2. Close the radiator drain plug securely after the coolant is drained.
3. Fill the radiator slowly with the proper mixture of antifreeze solution and demineralized water/distilled water. Fill the reservoir tank up to the MAX level. Then install the radiator filler cap.
4. Start the engine and warm it up until it reaches normal operating temperature. Then race the engine 2 or 3 times under no load. Watch the engine coolant temperature gauge for signs of overheating.
5. Stop the engine. After it completely cools down, refill the radiator up to the filler opening. Fill the reservoir tank up to the MAX level. Check the drain plug for any sign of leakage.
6. Check the coolant level again after driving the vehicle.

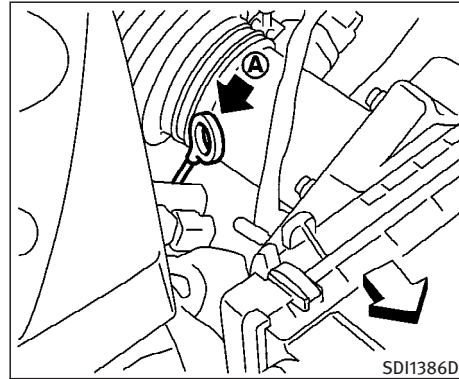

CHECKING ENGINE OIL LEVEL

1. Park the vehicle on a level surface and apply the parking brake.
2. Run the engine until it reaches operating temperature.
3. Turn off the engine. **Wait more than 10 minutes for the oil to drain back into the oil pan.**
4. Remove the dipstick (A) and wipe it clean. Reinsert it all the way.

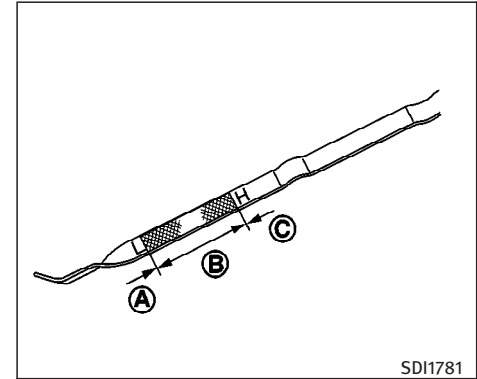

5. Remove the dipstick again and check the oil level. It should be between the H and L marks (B). If the oil level is below the L mark (A), remove the oil filler cap and pour recommended oil through the opening. **Do not overfill (C).**
6. Recheck oil level with dipstick.

It is normal to add some oil between oil maintenance intervals or during the break-in period, depending on the severity of operating conditions.



CAUTION

Oil level should be checked regularly. Operating the engine with an insufficient amount of oil can damage the engine, and such damage is not covered by warranty.

CHANGING ENGINE OIL AND FILTER

Change the engine oil and filter according to the maintenance intervals shown in the INFINITI Service and Maintenance Guide.

Vehicle set-up

1. Park the vehicle on a level surface and apply the parking brake.
2. Run the engine until it reaches operating temperature.
3. Turn the engine off and wait more than 10 minutes.
4. Raise and support the vehicle using a suitable floor jack and safety jack stands.
 - Place the safety jack stands under the vehicle jack-up points.
 - A suitable adapter should be attached to the jack stand saddle.

5. Remove the plastic engine undercover.
 - a. Remove the small plastic clip at the center point of the undercover.
 - b. Then remove the other bolts that hold the undercover in place.



CAUTION

Make sure the correct lifting and support points are used to avoid vehicle damage.

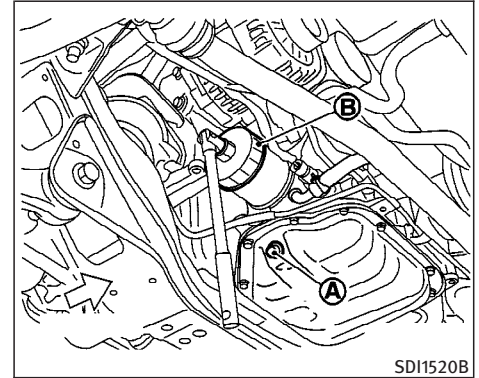

Engine oil and filter

1. Place a large drain pan under the drain plug.
2. Remove the oil filler cap.
3. Remove the drain plug **A** with a wrench and completely drain the oil.



CAUTION

Be careful not to burn yourself, as the engine oil is hot.

- **Waste oil must be disposed of properly.**
- **Check your local regulations.**

4. Loosen the oil filter with an oil filter wrench (B). Remove the oil filter by turning it by hand.
5. Wipe the engine oil filter mounting surface with a clean rag.

Be sure to remove any old rubber gasket remaining on the mounting surface of the engine.

6. Coat the gasket on the new filter with clean engine oil.
7. Screw in the oil filter clockwise until a slight resistance is felt, then tighten additionally more than 2/3 turn.

Oil filter tightening torque:

**11 to 15 ft-lb
(14.7 to 20.5 N-m)**

8. Clean and re-install the drain plug with a new washer. Securely tighten the drain plug with a wrench.

Drain plug tightening torque:

**22 to 29 ft-lb
(29 to 39 N-m)**

Do not use excessive force.

8-12 Maintenance and do-it-yourself

9. Refill engine with recommended oil and install the cap securely.



CAUTION

The dipstick must be inserted in place to prevent oil spillage from the dipstick hole while filling the engine with oil.

See “Capacities and recommended fuel/lubricants” in the “9. Technical and consumer information” section for drain and refill capacity. The drain and refill capacity depends on the oil temperature and drain time. Use these specifications for reference only. Always use the dipstick to determine the proper amount of oil in the engine.



CAUTION

When filling oil, do not pull out the dipstick.

10. Start the engine and check for leakage around the drain plug and the oil filter. Correct as required.

11. Turn the engine off and wait more than 10 minutes. Check the oil level with the dipstick. Add engine oil if necessary.

After the operation

1. Install the engine undercover into position as the following steps.
 - a. Pull the center of the small plastic clip out.
 - b. Hold the engine undercover into position.
 - c. Insert the clip through the undercover into the hole in the frame, then push the center of the clip in to lock the clip in place.
 - d. Install the other bolts that hold the undercover in place. Be careful not to strip the bolts or over-tighten them.
2. Lower the vehicle carefully to the ground.
3. Dispose of waste oil and filter properly.



WARNING

- Prolonged and repeated contact with used engine oil may cause skin cancer.
- Try to avoid direct skin contact with used oil. If skin contact is made, wash thoroughly with soap or hand cleaner as soon as possible.
- Keep used engine oil out of reach of children.

AUTOMATIC TRANSMISSION FLUID

When checking or replacement is required, we recommend an INFINITI dealer for servicing.



CAUTION

- Use only Genuine NISSAN Matic J ATF. Do not mix with other fluids.
- Using automatic transmission fluid other than Genuine NISSAN Matic J ATF will cause deterioration in driveability and automatic transmission durability, and may damage the automatic transmission, which is not covered by the INFINITI new vehicle limited warranty.

The specified automatic transmission fluid is also described on caution labels located in the engine compartment.

POWER STEERING FLUID

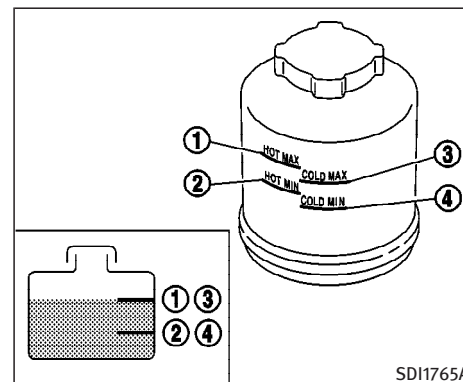

Check the fluid level in the reservoir.

The fluid level should be checked using the HOT range (①: HOT MAX., ②: HOT MIN.) at fluid temperatures of 122 to 176°F (50 to 80°C) or using the COLD range (③: COLD MAX., ④: COLD MIN.) at fluid temperatures of 32 to 86°F (0 to 30°C).



CAUTION

- Do not overfill.
- Use Genuine NISSAN PSF or equivalent.

BRAKE AND CLUTCH FLUID

For additional brake fluid specification information, refer to “Capacities and recommended fuel/lubricants” in the “9. Technical and consumer information” section.



WARNING

Use only new fluid. Old, inferior, or contaminated fluid may damage the brake system. Do not add synthetic brake fluid. The use of improper fluids can damage the brake system and affect the vehicle’s stopping ability.



CAUTION

Do not spill the fluid on any painted surfaces. This will damage the paint. If fluid is spilled, immediately wash the surface with water.

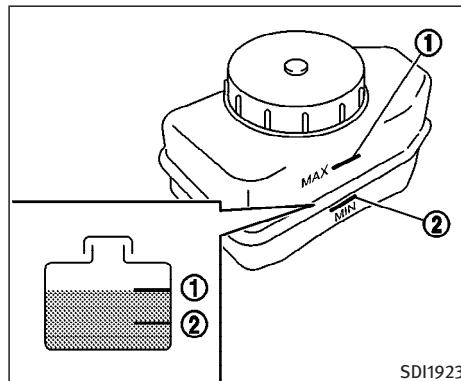

BRAKE FLUID

Check the fluid level in the reservoir. If the fluid is below the MIN line ② or the brake warning light comes on, add Genuine Nissan Super Heavy Duty Brake Fluid or equivalent **DOT 3** fluid up to the MAX line ①. If fluid must be added frequently, the system should be thoroughly checked by an INFINITI dealer.

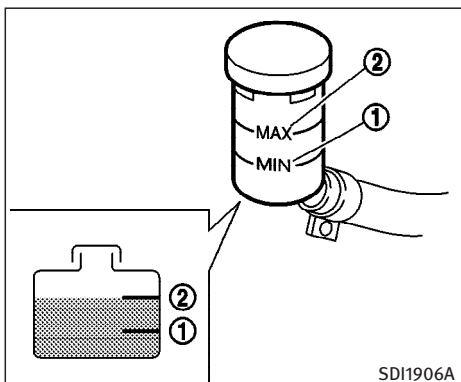

CLUTCH FLUID

Check the fluid level in the reservoir. If the fluid level is below the MIN line ②, add Genuine Nissan Super Heavy Duty Brake Fluid or equivalent **DOT 3** fluid up to the MAX line ①.

If fluid is added frequently, the system should be thoroughly checked by an INFINITI dealer.

WARNING

Use only new fluid from a sealed container. Old, inferior or contaminated fluid may damage the clutch system.

CAUTION

Do not spill the fluid on painted surfaces. This will damage the paint. If fluid is spilled, wash the surface with water.

WINDOW WASHER FLUID

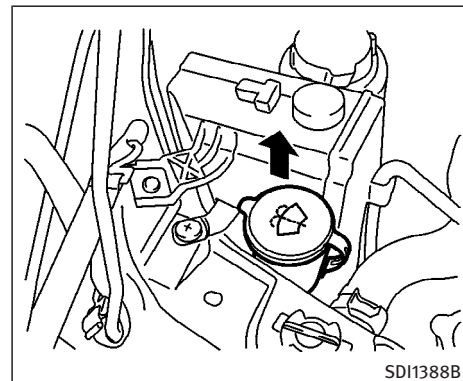

Add fluid when the low washer fluid warning light comes on. Pull up the cap and add a washer solvent to the water for better cleaning. In the winter season, add a windshield washer antifreeze. Follow the manufacturer's instructions for the mixture ratio.

Recommended fluid is Genuine NISSAN Windshield Washer Concentrate Cleaner & Antifreeze or equivalent.



WARNING

Antifreeze is poisonous and should be stored carefully in marked containers out of the reach of children.



CAUTION

Do not substitute engine anti-freeze coolant for window washer solution. This may result in damage to the paint.

- Do not fill the window washer reservoir tank with washer fluid concentrates at full strength. Some methyl alcohol based washer fluid concentrates may permanently stain the grille if spilled while filling the window washer reservoir tank.
- Pre-mix washer fluid concentrates with water to the manufacturer's recommended levels before pouring the fluid into the window washer reservoir tank.

Do not use the window washer reservoir tank to mix the washer fluid concentrate and water.

BATTERY

- Keep the battery surface clean and dry. Any corrosion should be washed off with a solution of baking soda and water.
- Make certain the terminal connections are clean and securely tightened.
- If the vehicle is not to be used for 30 days or longer, disconnect the (-) negative battery terminal cable to prevent discharging it.

Coupe



CAUTION

When the battery cable is removed from the battery terminal, do not close either of front doors. The automatic window adjusting function will not work, and the side roof panel may be damaged.

To disconnect the negative (-) battery terminal, perform the procedure in the following order. Otherwise, the window and the side roof panel may contact and be damaged.

1. Close the windows.

2. Open the hood.
3. Close and lock all the doors.
4. Disconnect the negative (-) battery terminal.
5. Securely close the hood.

To connect the negative (-) battery terminal, perform the procedure in the following order. Otherwise, the window and the side roof panel may contact and be damaged.

1. Unlock and open the driver side door. Do not close the door.
2. Open the hood.
3. Connect the negative (-) battery terminal. Then close the hood.
4. Fully open the driver side door window.
5. Close the driver side door and the window.

Sedan and coupe



WARNING

- Do not expose the battery to flames or electrical sparks. Hydrogen gas, generated by battery fluid, is explosive. Do not allow battery fluid to contact your skin, eyes, fabrics, or painted surfaces. After touching a battery or battery cap, do not touch or rub your eyes. Thoroughly wash your hands. If the acid contacts your eyes, skin or clothing, immediately flush with water for at least 15 minutes and seek medical attention.
- Do not operate the vehicle if the fluid in the battery is low. Low battery fluid can cause a higher load on the battery which can generate heat, reduce battery life, and in some cases lead to an explosion.
- When working on or near a battery, always wear suitable eye protection and remove all jewelry.
- Battery posts, terminals and related accessories contain lead and lead compounds. Wash hands after handling.

- Keep the battery out of the reach of children.

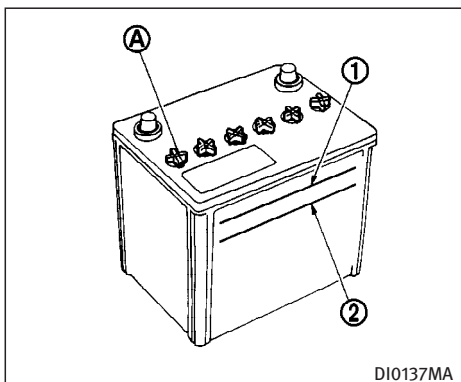

Check the fluid level in each cell. It should be between the UPPER LEVEL ① and LOWER LEVEL ② lines.

If it is necessary to add fluid, add only distilled water to bring the level to the indicator in each filler opening. **Do not over-fill.**

1. Remove the cell plugs ①.
2. Add distilled water up to the UPPER LEVEL ①.

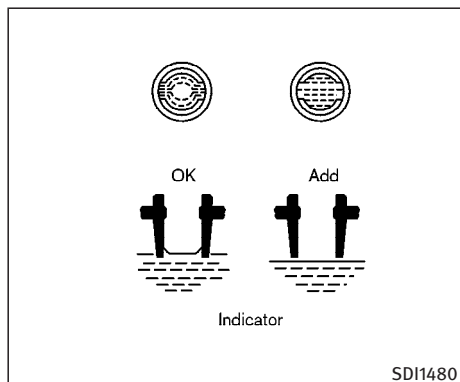

If the side of the battery is not visible, the electrolyte level can be checked through each filler opening as illustrated.

3. Tighten cell plugs ①.

Vehicles operated in high temperatures or under severe conditions require frequent checks of the battery fluid level.

JUMP STARTING

If jump starting is necessary, see “Jump starting” in the “6. In case of emergency” section. If the engine does not start by jump starting, the battery may have to be replaced. Contact an INFINITI dealer.

DRIVE BELTS

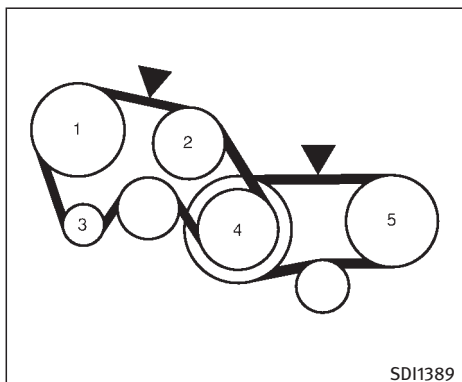

1. Power steering fluid pump
 2. Fan
 3. Alternator
 4. Crankshaft pulley
 5. Air conditioner compressor
- ▼: Tension checking points



WARNING

Be sure the ignition key is in the OFF or LOCK position. The engine could rotate unexpectedly.

1. Visually inspect each belt for signs of unusual wear, cuts, fraying, oil adhesion or looseness. If the belt is in poor condition or loose, have it replaced or adjusted by an INFINITI dealer.
2. Have the belts checked regularly for condition and tension in accordance with the maintenance schedule in the INFINITI Service and Maintenance Guide.



WARNING

Be sure the engine and ignition switch are off and that the parking brake is engaged securely.



CAUTION

Be sure to use the correct socket to remove the spark plugs. An incorrect socket can damage the spark plugs.

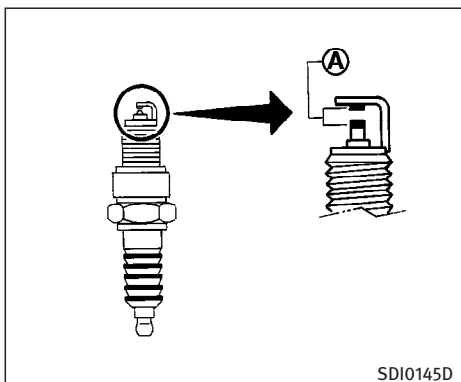

Always replace with recommended platinum-tipped spark plugs.

REPLACING SPARK PLUGS

If replacement is required, see an INFINITI dealer for servicing.

Platinum-tipped spark plugs

It is not necessary to replace the platinum-tipped (A) spark plugs as frequently as the conventional type spark plugs since they will last much longer. Follow the maintenance schedule in the INFINITI Service and Maintenance Guide, but do not reuse them by cleaning or re-gapping.

AIR CLEANER

If maintenance is required, see an INFINITI dealer for servicing.

The filter element should not be cleaned and reused. Replace it according to the maintenance intervals. See the INFINITI Service and Maintenance Guide. When replacing the filter, wipe the inside of the air cleaner housing and the cover with a damp cloth.



WARNING

- **Operating the engine with the air cleaner removed can cause you or others to be burned. The air cleaner not only cleans the air, it stops the flame if the engine backfires. If it is not there, and the engine backfires, you could be burned. Do not drive with the air cleaner removed, and be careful when working on the engine with the air cleaner removed.**
- **Never pour fuel into the throttle body or attempt to start the engine with the air cleaner removed. Doing so could result in serious injury.**

WINDSHIELD WIPER BLADES



CAUTION

- **After wiper blade replacement, return the wiper arm to its original position.**

Otherwise it may be damaged when the engine hood is opened.

- **Make sure the wiper blades contact the glass, otherwise the arms may be damaged from wind pressure.**
- **Worn windshield wiper blades can damage the windshield and impair driver vision.**

tergent. Then rinse the blade with clear water. If your windshield is still not clear after cleaning the blades and using the wiper, replace the blades.

CLEANING

If your windshield is not clear after using the windshield washer or if a wiper blade chatters when running, wax or other material may be on the blade or windshield.

Clean the outside of the windshield with a washer solution or a mild detergent. Your windshield is clean if beads do not form when rinsing with clear water.

Clean the blade by wiping it with a cloth soaked in a washer solution or a mild de-

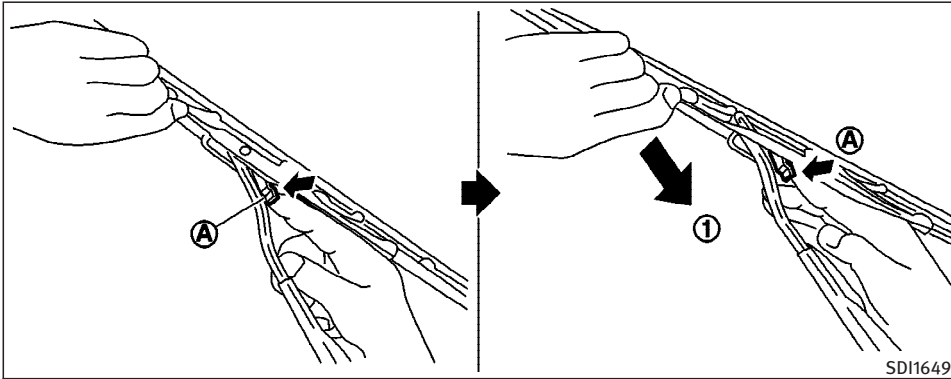

REPLACING

Replace the wiper blades if they are worn.

1. Pull the wiper arm.
2. Push and hold the release tab (A), then move the wiper blade down the wiper arm to remove (1).
3. Insert the new wiper blade to the wiper arm until a click sounds.

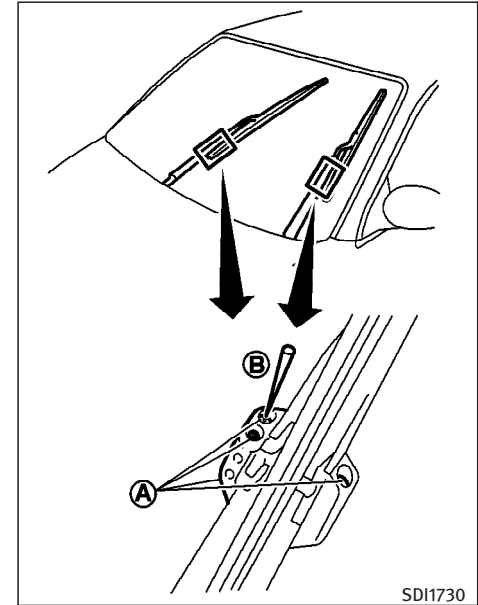

If necessary, clean the windshield washer nozzle (A) with a needle or small pin (B).

PARKING BRAKE AND BRAKE PEDAL

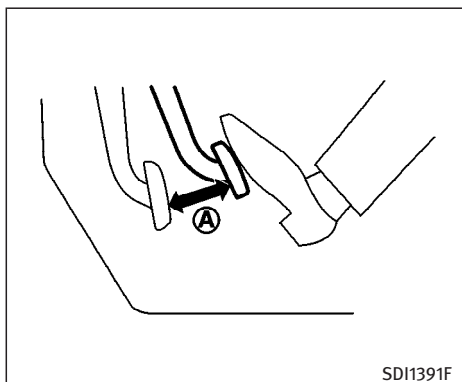

CHECKING PARKING BRAKE

Pedal type

From the released position, depress the parking brake pedal slowly and firmly, and check the notches between the initial and final position of the pedal (A). If it is out of the range, see an INFINITI dealer.

Range (A): 2 to 3 notches under a depressing force of 44 lb (196 N)

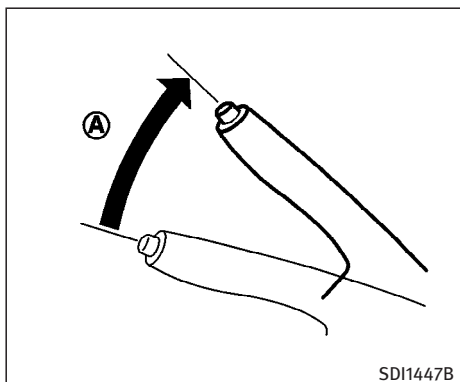

Lever type

From the released position, pull the parking brake lever up slowly and firmly. If the number of clicks is out of the range (A), see an INFINITI dealer.

Range (A): 6 to 7 clicks under pulling force of 44 lb (196 N)

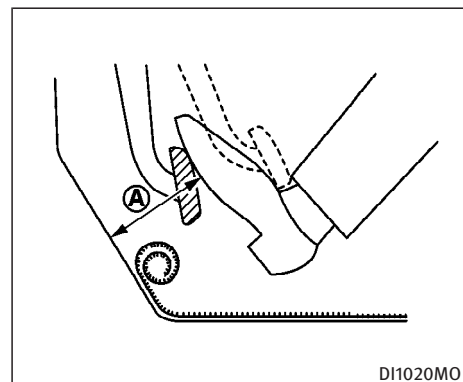

CHECKING BRAKE PEDAL

With the engine running, check the distance (A) between the upper surface of the pedal and the metal floor. If it is out of the range shown below, see an INFINITI dealer.

Distance (A): Under depressing force of 110 lb (490 N)

Automatic Transmission model	Manual Transmission model
3.74 in (95 mm) or more	3.54 in (90 mm) or more

Self-adjusting brakes

Your vehicle is equipped with self-adjusting brakes.

The disc-type brakes self-adjust every time the brake pedal is applied.



WARNING

See an INFINITI dealer for a brake system check if the brake pedal height does not return to normal.

Brake pad wear indicators

The disc brake pads on your vehicle have audible wear indicators. When a brake pad requires replacement, it will make a high pitched scraping or screeching sound when the vehicle is in motion whether or not the brake pedal is depressed. Have the brakes checked as soon as possible if the wear indicator sound is heard.

Under some driving or climate conditions, occasional brake squeak, squeal or other noise may be heard. Occasional brake noise during light to moderate stops is normal and does not affect the function or performance of the brake system.

8-24 Maintenance and do-it-yourself

Proper brake inspection intervals should be followed. For additional information, see the appropriate maintenance log shown in the INFINITI Service and Maintenance Guide.

High performance sports brake pads occasionally make squeaks, squeals or other braking noises because of their very high friction coefficient.

These occasional brake noises are normal, but if they continue, see an INFINITI dealer.

BRAKE BOOSTER

Check the brake booster function as follows:

1. With the engine off, press and release the brake pedal several times. When brake pedal movement (distance of travel) remains the same from one pedal application to the next, continue on to the next step.
2. While depressing the brake pedal, start the engine. The pedal height should drop a little.

3. With the brake pedal depressed, stop the engine. Keeping the pedal depressed for about 30 seconds, the pedal height should not change.
4. Run the engine for one minute without depressing the brake pedal, then turn it off. Depress the brake pedal several times. The pedal travel distance will decrease gradually with each depression as the vacuum is released from the booster.

If the brakes do not operate properly, see an INFINITI dealer.

2. Open the engine hood and remove the cover on the battery and the fuse/fusible link holder.
3. Remove the fuse/fusible link holder cover.
4. Remove the fuse with the fuse puller. The fuse puller is located in the passenger compartment fuse box.

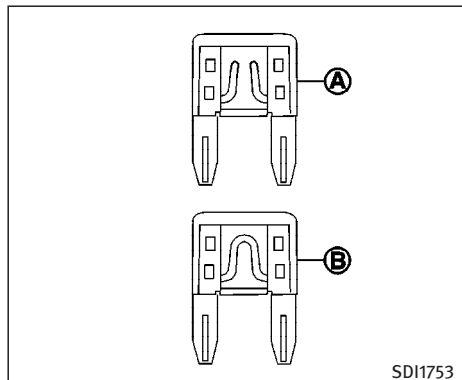

5. If the fuse is open (A), replace it with a new fuse (B). Spare fuses are stored in the passenger compartment fuse box.
6. If a new fuse also opens, have the electrical system checked and repaired by an INFINITI dealer.

Fusible links

If any electrical equipment does not operate and fuses are in good condition, check the fusible links. If any of these fusible links are melted, replace only with genuine INFINITI parts.

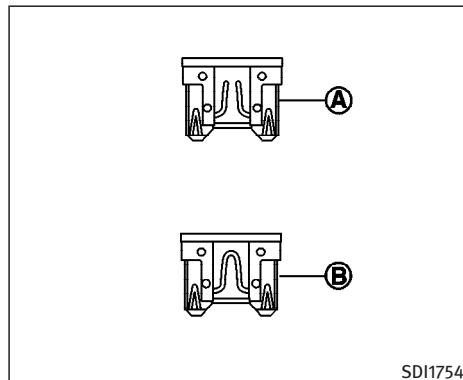
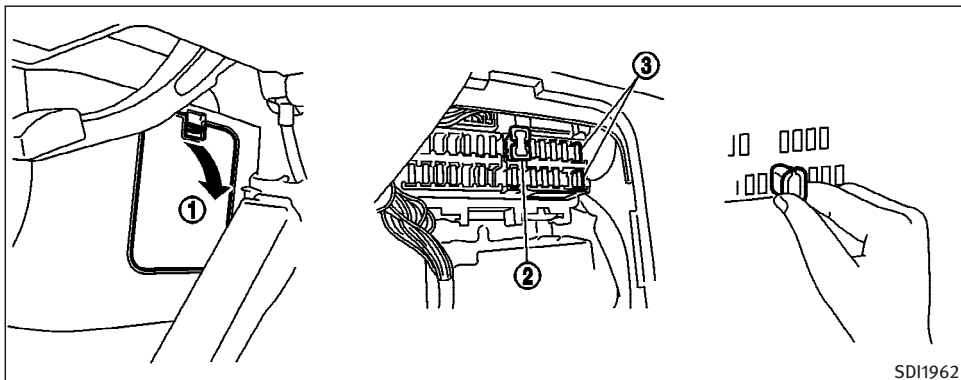

PASSENGER COMPARTMENT



CAUTION

Never use a fuse of a higher or lower amperage rating than that specified on the fuse box cover. This could damage the electrical system or cause a fire.

If any electrical equipment does not operate, check for an open fuse.

1. Be sure the ignition switch and the headlight switch are in the OFF position.
2. Open the fuse box lid ①.
3. Remove the fuse with the fuse puller ②.
4. If the fuse is open (A), replace it with a new fuse (B). Spare fuses ③ are stored in the fuse box.
5. If a new fuse also opens, have the electrical system checked and repaired by an INFINITI dealer.

KEYFOB BATTERY REPLACEMENT

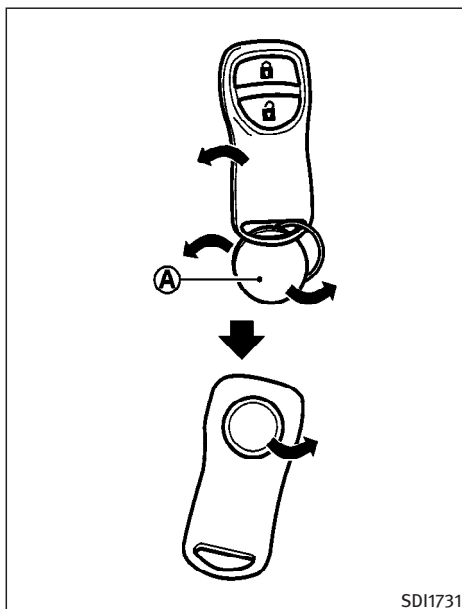

KEYFOB (except Intelligent Key)

Replace the battery as follows:

1. Open the lid using a suitable tool (A).

2. Replace the battery with a new one.
Recommended battery: CR2025 or equivalent

Make sure that the ⊕ side faces the bottom case.

3. Close the lid securely.
4. Push the keyfob button two or three times to check its operation.

See an INFINITI dealer if you need any assistance for replacement.

If the battery is removed for any reason other than replacement, perform step 4 above.

- Be careful not to touch the circuit board and the battery terminal.
- An improperly disposed battery can harm the environment. Always confirm local regulations for battery disposal.
- The keyfob is water-resistant; however, if it gets wet, immediately wipe it completely dry.
- When changing batteries, do not let dust or oil get on the keyfob.

FCC Notice:

Changes or modifications not expressly approved by the party responsible for compliance could void the user's authority to operate the equipment.

This device complies with Part 15 of the FCC Rules and RSS-210 of Industry Canada. Operation is subject to the following two conditions: (1) This device may not cause harmful interference, and (2) this device must accept any interference received, including interference that may cause undesired operation of the device.

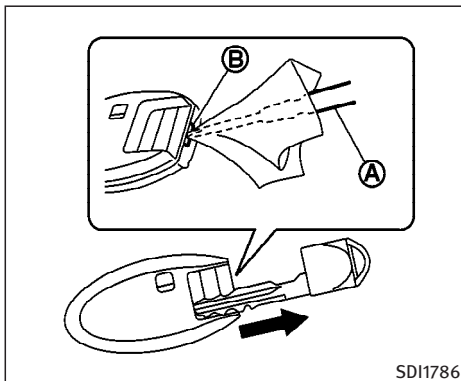

SDI1786

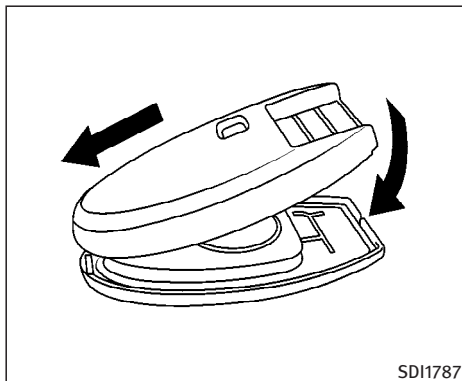

SDI1787

INTELLIGENT KEY



CAUTION

Be careful not to allow children to swallow the battery and removed parts.

Replace the battery as follows:

1. Release the lock knob at the back of the Intelligent Key and remove the mechanical key.

2. Insert a flat-blade screwdriver (A) wrapped with a cloth into the slit (B) of the corner and twist it to separate the upper part from the lower part.

3. Replace the battery with a new one.

- Do not touch the internal circuit and electric terminals as it could cause a malfunction.

Recommended battery: CR2025 or equivalent

Make sure that the ⊕ side faces the bottom of the case. The ⊕ mark is stamped on the bottom of the case.

4. Align the tips of the upper and lower parts, and then push them together until it is securely closed.

5. Push the buttons two or three times to check its operation.

See an INFINITI dealer if you need any assistance for replacement.

If the battery is removed for any reason other than replacement, perform step 5 above.

- **Be careful not to touch the circuit board and the battery terminal.**
- **An improperly disposed battery can harm the environment. Always confirm local regulations for battery disposal.**
- **When changing batteries, do not let dust or oil get on the Intelligent Key.**

FCC Notice:

This equipment has been tested and found to comply with the limits for a Class B digital device pursuant to part 15 of the FCC Rules. These limits are designed to provide reasonable protection against harmful interference in a residential installation. This equipment generates, uses and can radiate radio frequency energy and, if not installed and used in accordance with the

instructions, may cause harmful interference to radio communications. However, there is no guarantee that interference will not occur in a particular installation. If this equipment does cause harmful interference to radio or television reception, which can be determined by turning the equipment off and on, the user is encouraged to try to correct the interference by one or more of the following measures:

- Reorient or relocate the receiving antenna
- Increase the separation between the equipment and the receiver
- Connect the equipment into an outlet on a circuit different from that to which the receiver is connected.
- Consult the dealer or an experienced radio/TV technician for help.

LIGHTS

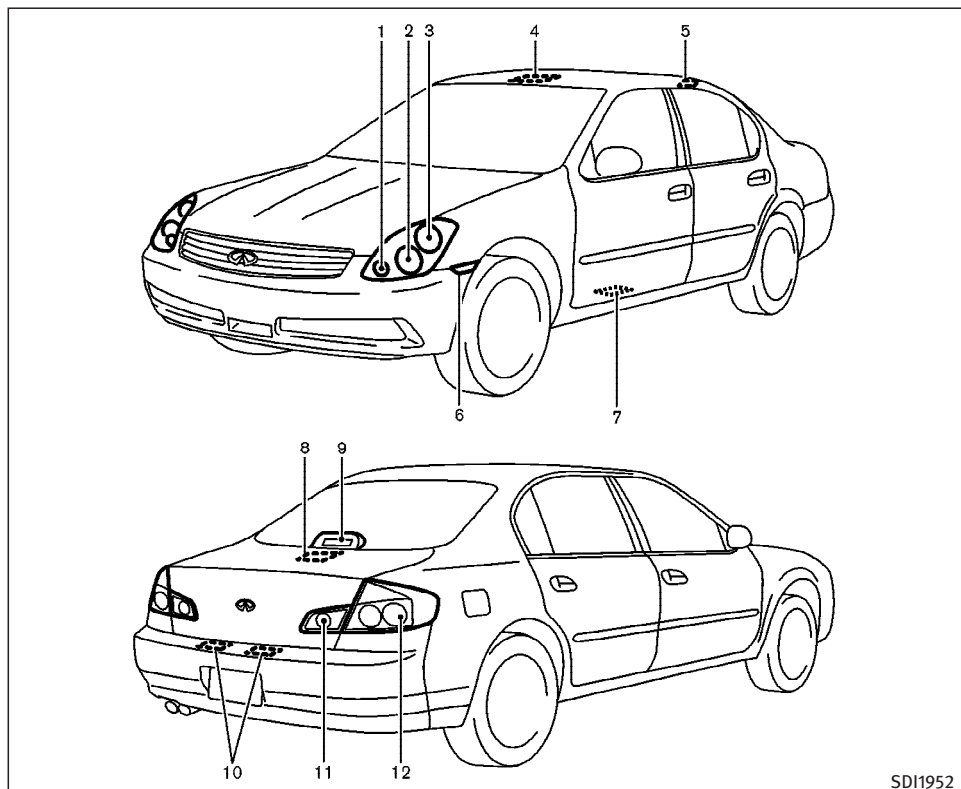

SD11952

Sedan

1. Front turn signal light
2. Front fog light/Park light/
Headlight (high-beam)
3. Headlight (low-beam)
4. Map light
5. Rear personal light
6. Front side marker light
7. Step light
8. Trunk light
9. High-mounted stop light
(if so equipped)
10. License plate light
11. Back-up light
12. Rear combination light
(Turn signal, Stop/Tail, Side marker)

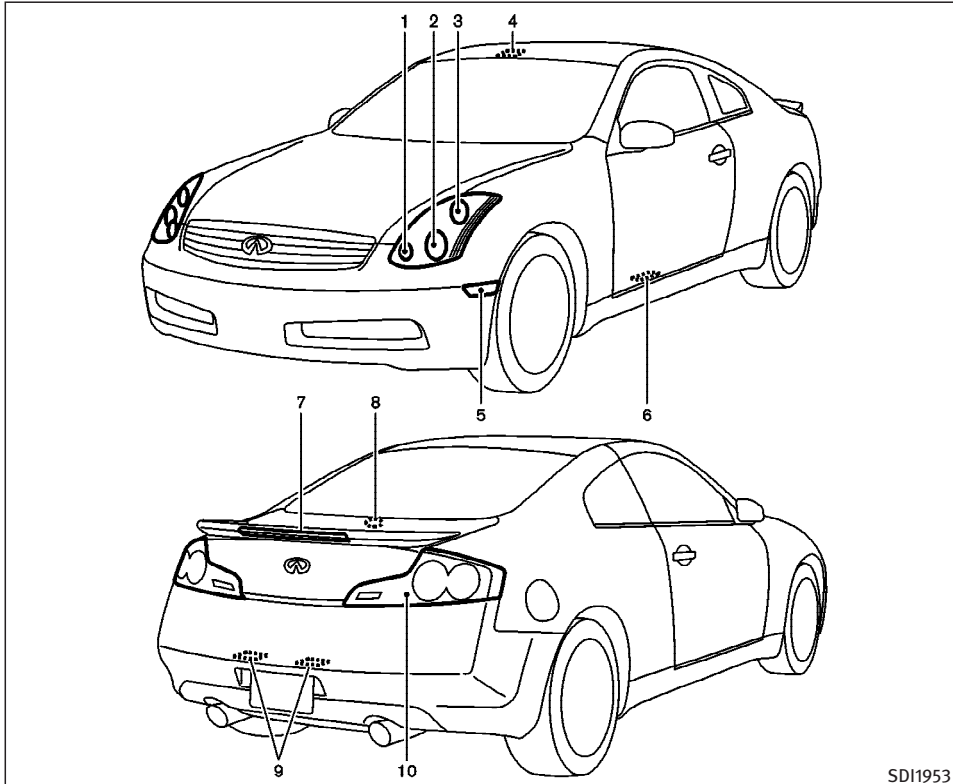

Coupe

1. Front turn signal light
2. Front fog light/Park light
3. Headlight (low-beam/high-beam)
4. Map light
5. Front side marker light
6. Step light
7. High-mounted stop light
(if so equipped)
8. Trunk light
9. License plate light
10. Rear combination light
(Turn signal, Stop/Tail, Back-up, Side
marker)

SDI1953

HEADLIGHTS

Replacing the xenon headlight bulb

Xenon headlight bulb:



WARNING



HIGH VOLTAGE

When xenon headlights are on, they produce a high voltage. To prevent an electric shock, never attempt to modify or disassemble. Always have your xenon headlights replaced at an INFINITI dealer. For additional information, see “Headlight and turn signal switch” in the “2. Instruments and controls” section.

If replacement is required, see an INFINITI dealer.

EXTERIOR AND INTERIOR LIGHTS

Item	Wattage (W)	Bulb No.
Front turn signal light*	21	T20
Front park light*	5	T10
Front side marker light	3.8	T10
Front fog light	Sedan: 60/55 Coupe: 55	Sedan: H4 Coupe: H1
Rear combination light		
Turn signal	21	T20
Stop/Tail*	(LED)	—
Side marker light*	Sedan: (LED)/Coupe: 3.8	Sedan: —/Coupe: T10
Back-up light	18	T16
License plate light	5	T10
High-mounted stop light*	(LED)	—
Map light	8	—
Rear personal light (Sedan)	8	—
Step light	5	—
Trunk light	3.4	158
Vanity mirror light	1.32	—

*: See an INFINITI dealer for replacement.

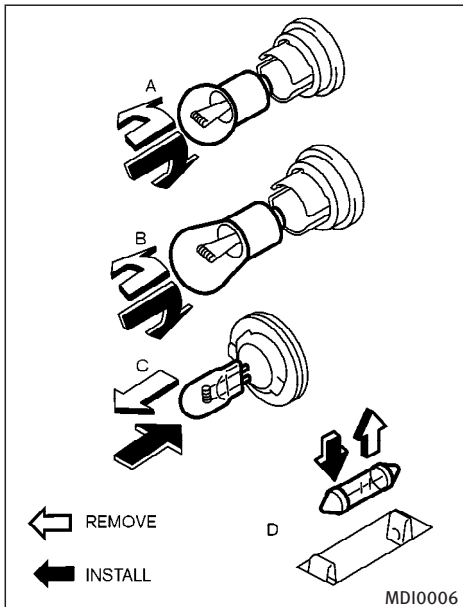

Replacement procedures

All other lights are either type A, B, C or D. When replacing a bulb, first remove the lens and/or cover.

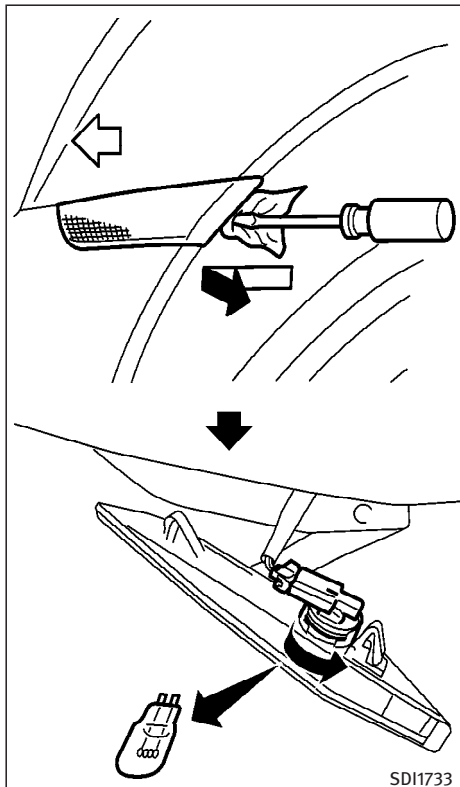

Front side marker light

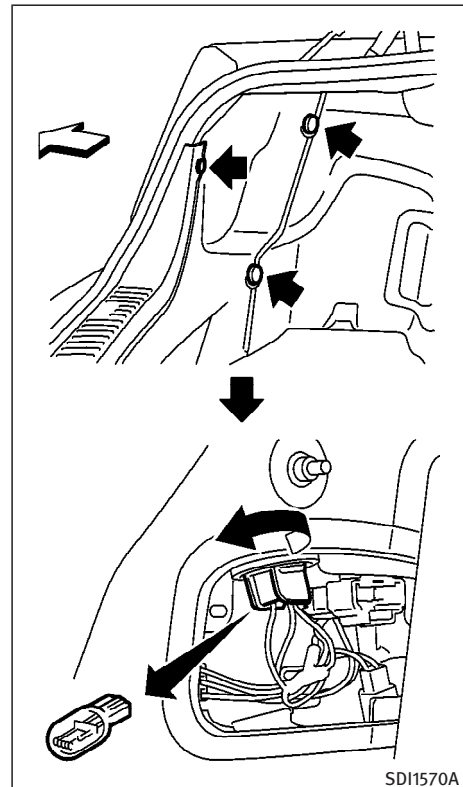

Sedan — Rear turn signal light

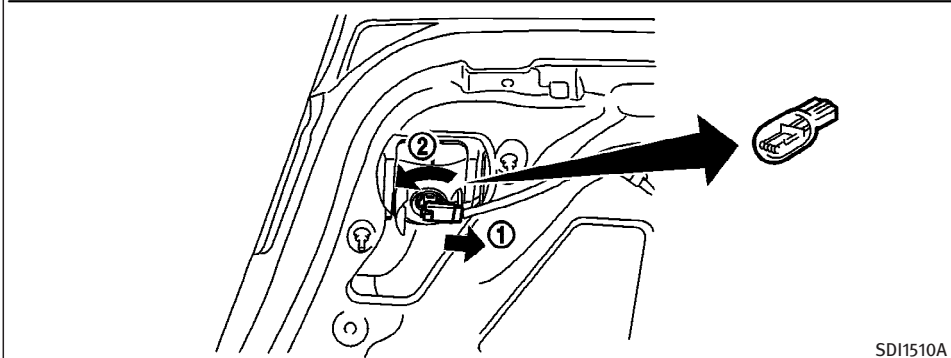
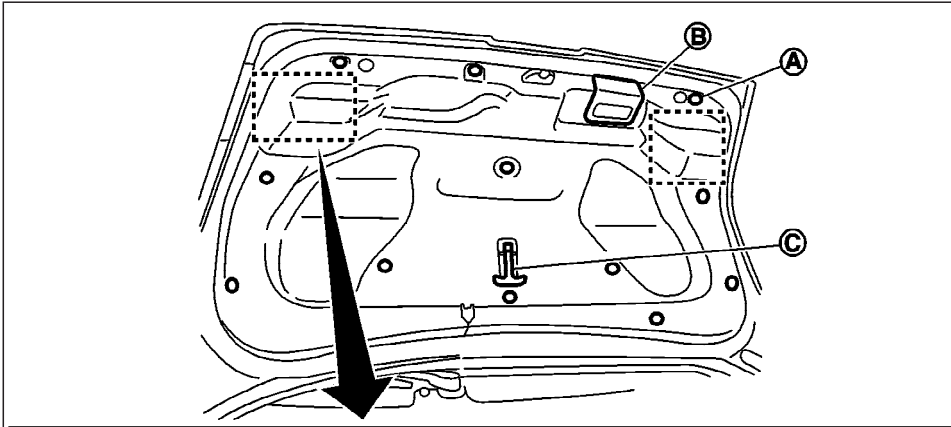

Sedan — Back-up light

SDI1510A

To replace a back-up light

1. Remove all the clips (A), the handle (B) and inside release handle (C) to remove the trunk lid finisher.
2. Remove the connector from bulb socket (1).
3. Turn the bulb socket counterclockwise (2) and remove the bulb.

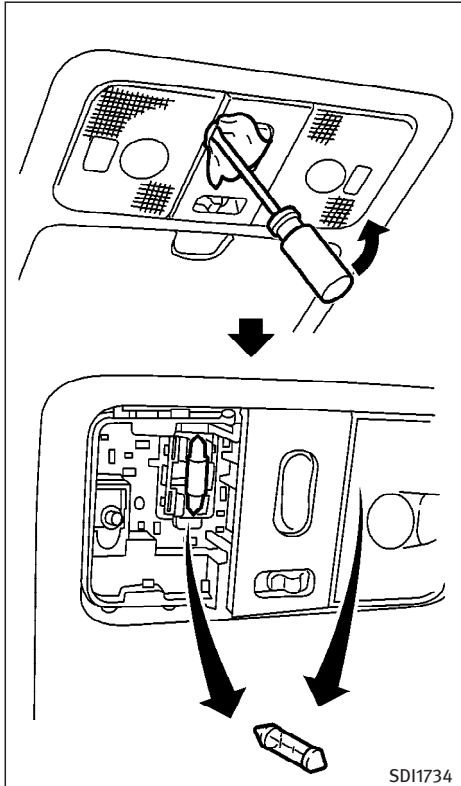

SDI1734

Map light

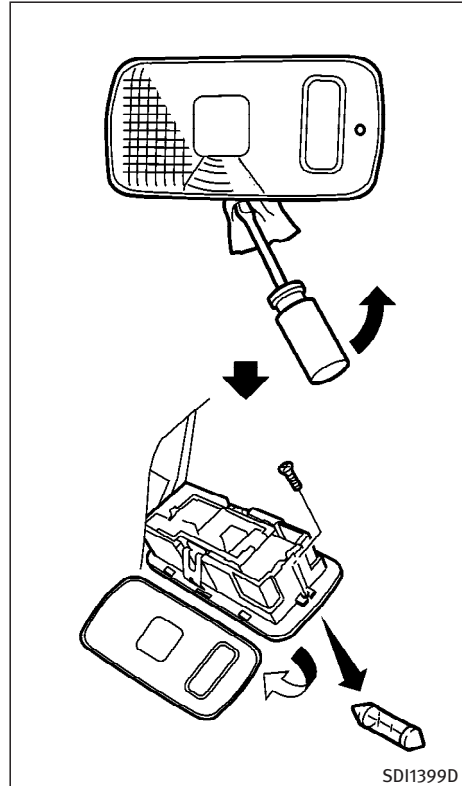

SDI1399D

Sedan — Rear personal light

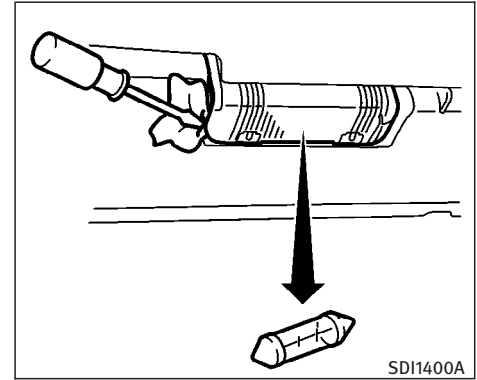

SDI1400A

Step light

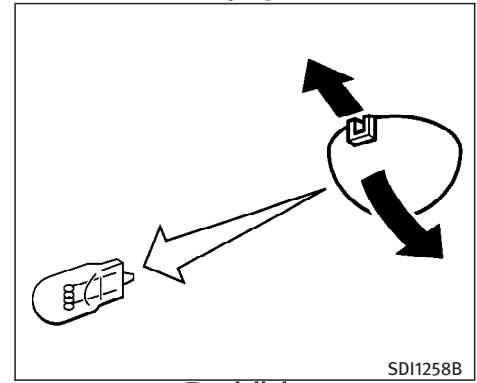

SDI1258B

Trunk light

WHEELS AND TIRES

TIRE PRESSURE

Tire pressure monitoring system (TPMS)

This vehicle is equipped with the tire pressure monitoring system (TPMS). It monitors tire pressure of all tires except the spare. When the low tire pressure warning light is lit, one or more of your tires is significantly under-inflated.

The TPMS will activate only when the vehicle is driven at speeds above 16 MPH (25 km/h). Also, this system may not detect a sudden drop in tire pressure (for example a flat tire while driving).

For more details, refer to “Low tire pressure warning light” in the “2. Instruments and controls” section, “Tire pressure monitoring system (TPMS)” in the “5. Starting and driving” section, and “Flat tire” in the “6. In case of emergency” section.

Tire inflation pressure

Check the tire pressure of the tires (including the spare) often and always prior to long distance trips. The recommended tire pressure specifications are shown on the F.M.V.S.S./C.M.V.S.S. label or the Tire and Loading Information label under the “COLD TIRE PRESSURE” heading. The Tire and Loading Information label is affixed to the driver side center pillar. Tire pressures should be checked regularly because:

- Most tires naturally lose air over time.
- Tires can lose air suddenly when driven over potholes or other objects or if the vehicle strikes a curb while parking.

The tire pressures should be checked when the tires are cold. The tires are considered COLD after the vehicle has been parked for 3 or more hours, or driven less than 1 mile (1.6 km) at moderate speeds.

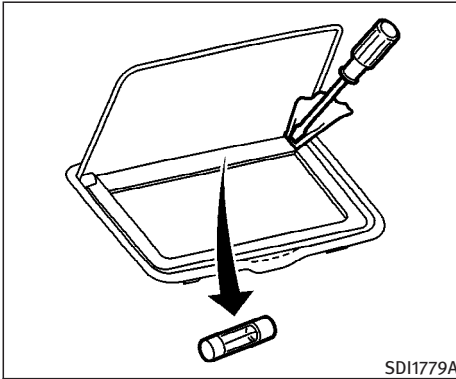

Vanity mirror light

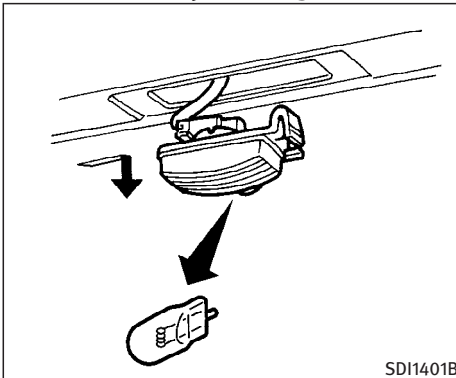

License plate light

Incorrect tire pressure, including under inflation, may adversely affect tire life and vehicle handling.



WARNING

- Improperly inflated tires can fail suddenly and cause an accident.
- The Gross Vehicle Weight Rating (GVWR) is located on the F.M.V.S.S./C.M.V.S.S. label. The vehicle weight capacity is indicated on the Tire and Loading Information label. Do not load your vehicle beyond this capacity. Overloading your vehicle may result in reduced tire life, unsafe operating conditions due to premature tire failure, or unfavorable handling characteristics and could also lead to a serious accident. Loading beyond the specified capacity may also result in a malfunction of other vehicle components.
- Before taking a long trip, or whenever you heavily load your vehicle, use a tire pressure gauge to ensure that the tire pressures are at the specified level.
- Do not drive your vehicle over 85 MPH (137 km/h) unless it is equipped with high speed rated tires. Driving faster than 85 MPH (137 km/h) may result in tire malfunction, loss of control and possible injury.
- For additional information regarding tires, refer to “Important Tire Safety Information” (US) or “Tire Safety Information” (Canada) in the Warranty Information Booklet.

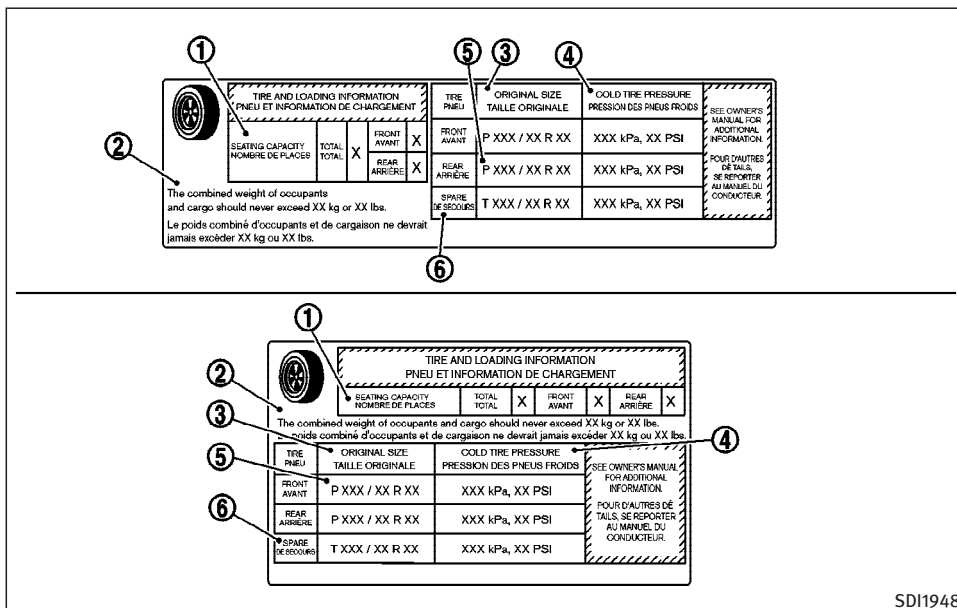

③ Original size: The size of the tires originally installed on the vehicle at the factory.

④ Cold tire pressure: Inflate the tires to this pressure when the tires are cold. Tires are considered COLD after the vehicle has been parked for 3 or more hours, or driven less than 1 mile (1.6 km) at moderate speeds. The recommended cold tire inflation is set by the manufacturer to provide the best balance of tire wear, vehicle handling, driveability, tire noise, etc., up to the vehicle's GVWR.

⑤ Tire size – refer to “Tire labeling” later in this section.

⑥ Spare tire size or compact spare tire size (if so equipped)

Tire and loading information label

① Seating capacity: The maximum number of occupants that can be seated in the vehicle.

② Vehicle load limit: See loading information in the “Technical and consumer information” section.

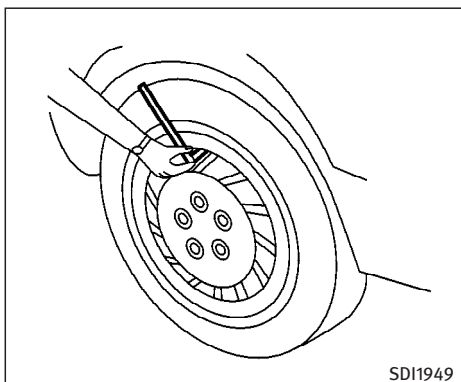

Checking the tire pressure

1. Remove the valve stem cap from the tire.
2. Press the pressure gauge squarely onto the valve stem. Do not press too hard or force the valve stem sideways, or air will escape. If the hissing sound of air escaping from the tire is heard while checking the pressure, reposition the gauge to eliminate this leakage.

3. Remove the gauge.
4. Read the tire pressure on the gauge stem and compare it to the specification shown on the Tire and Loading Information label.
5. Add air to the tire as needed. If too much air is added, press the core of the valve stem briefly with the tip of the gauge stem to release pressure. Recheck the pressure and add or release air as needed.
6. Install the valve stem cap.
7. Check the pressure of all other tires, including the spare. (Refer to the “Wheels and tires” section)

Sedan model	Size	Cold Tire Inflation Pressure
Front Original Tire	P215/55R17 93V	210 kPa (30 psi)
	235/45R18 94W	230 kPa (33 psi)
Rear Original Tire	P215/55R17 93V	210 kPa (30 psi)
	235/45R18 94W	230 kPa (33 psi)
Spare Tire	T145/80D17	420 kPa (60 psi)
	P215/55R17 93V*1	210 kPa (30 psi)

*1 Option for USA, conventional for Canada (for models with tire size P215/55R17 93V)

Coupe model	Size	Cold Tire Inflation Pressure
Front Original Tire	P225/50R17 93V	210 kPa (30 psi)
	225/45R18 91W	240 kPa (35 psi)
	225/40R19 89Y	240 kPa (35 psi)
Rear Original Tire	P235/50R17 95V	210 kPa (30 psi)
	245/45R18 96W	240 kPa (35 psi)
	245/40R19 94Y	240 kPa (35 psi)
Spare Tire	T145/80D17	420 kPa (60 psi)

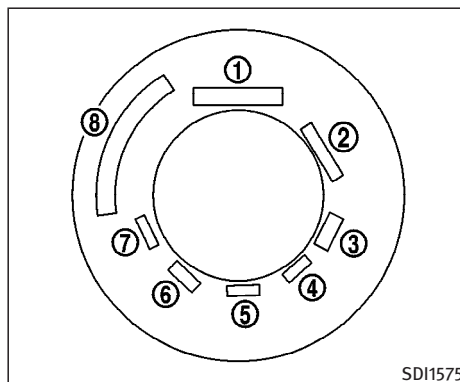

Example

TIRE LABELING

Federal law requires tire manufacturers to place standardized information on the sidewall of all tires. This information identifies and describes the fundamental characteristics of the tire and also provides the tire identification number (TIN) for safety standard certification. The TIN can be used to identify the tire in case of a recall.

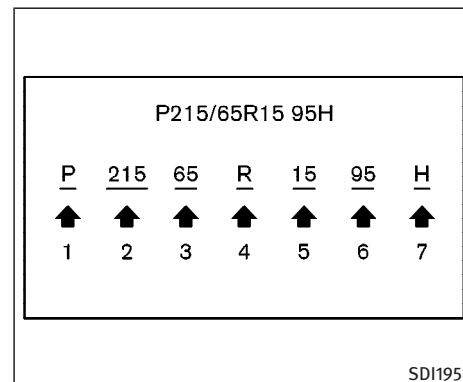

Example

① Tire size (example: P215/65R15 95H)

1. P: The “P” indicates the tire is designed for passenger vehicles. (Not all tires have this information).
2. Three-digit number (215): This number gives the width in millimeters of the tire from sidewall edge to sidewall edge.
3. Two-digit number (65): This number, known as the aspect ratio, gives the tire’s ratio of height to width.

4. R: The “R” stands for radial.
5. Two-digit number (15): This number is the wheel or rim diameter in inches.
6. Two- or three-digit number (95): This number is the tire’s load index. It is a measurement of how much weight each tire can support. You may not find this information on all tires because it is not required by law.
7. H: Tire speed rating. You should not drive the vehicle faster than the tire speed rating.

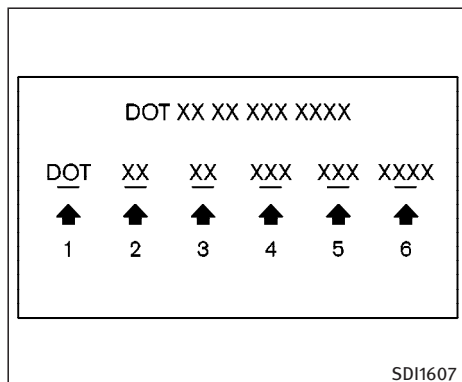

Example

- ② TIN (Tire Identification Number) for a new tire (example: DOT XX XX XXX XXXX)
 1. DOT: Abbreviation for the “Department of Transportation”. The symbol can be placed above, below or to the left or right of the Tire Identification Number.
 2. Two-digit code: Manufacturer’s identification mark
 3. Two-digit code: Tire size

4. Three-digit code: Tire type code (Optional)
5. Three-digit code: Date of Manufacture
6. Four numbers represent the week and year the tire was built. For example, the numbers 3103 mean the 31st week of 2003. If these numbers are missing, then look on the other sidewall of the tire.
- ③ Tire ply composition and material

The number of layers or plies of rubber-coated fabric in the tire. Tire manufacturers also must indicate the materials in the tire, which include steel, nylon, polyester, and others.
- ④ Maximum permissible inflation pressure

This number is the greatest amount of air pressure that should be put in the tire. Do not exceed the maximum permissible inflation pressure.

- ⑤ **Maximum load rating**
This number indicates the maximum load in kilograms and pounds that can be carried by the tire. When replacing the tires on the vehicle, always use a tire that has the same load rating as the factory installed tire.
- ⑥ **Term of “tubeless” or “tube type”**
Indicates whether the tire requires an inner tube (“tube type”) or not (“tubeless”).
- ⑦ **The word “radial”**
The word “radial” is shown if the tire has radial structure.
- ⑧ **Manufacturer or brand name**
Manufacturer or brand name is shown.

Other tire-related terminology:

In addition to the many terms that are defined throughout this section, Intended Outboard Sidewall is (1) the sidewall that contains a whitewall, bears white lettering or bears manufac-

turer, brand and/or model name molding that is higher or deeper than the same molding on the other sidewall of the tire, or (2) the outward facing sidewall of an asymmetrical tire that has a particular side that must always face outward when mounted on a vehicle.

TYPES OF TIRES



WARNING

- **When changing or replacing tires, be sure all four tires are of the same type (i.e., Summer, All Season or Snow) and construction. An INFINITI dealer may be able to help you with information about tire type, size, speed rating and availability.**
- **Replacement tires may have a lower speed rating than the factory equipped tires, and may not match the potential maximum vehicle speed. Never exceed the maximum speed rating of the tire.**
- **Replacing tires with those not originally**

specified by INFINITI could affect the proper operation of the tire pressure monitoring system (TPMS).

- **For additional information regarding tires, refer to “Important Tire Safety Information” (US) or “Tire Safety Information” (Canada) in the Warranty Information Booklet.**

All season tires

INFINITI specifies All Season tires on some models to provide good performance for use all year, including snowy and icy road conditions. All Season tires are identified by ALL SEASON and/or M&S on the tire sidewall. Snow tires have better snow traction than All Season tires and may be more appropriate in some areas.

Summer tires

INFINITI specifies summer tires on some models to provide superior performance on dry roads. Summer tire performance is substantially reduced in snow and ice. Summer tires do not have the tire traction rating “M&S” on the tire sidewall.

If you plan to operate your vehicle in snowy or icy conditions, INFINITI recom-

mends the use of SNOW or ALL SEASON tires on all four wheels.

Snow tires

If snow tires are needed, it is necessary to select tires equivalent in size and load rating to the original equipment tires. If you do not, it can adversely affect the safety and handling of your vehicle.

Generally, snow tires will have lower speed ratings than factory equipped tires and may not match the potential maximum vehicle speed. Never exceed the maximum speed rating of the tire.

If you operate your vehicle in snowy or icy conditions, INFINITI recommends the use of snow or all season tires on all four wheels.

For additional traction on icy roads, studded tires may be used. However, some provinces and states prohibit their use. Check local, state and provincial laws before installing studded tires. Skid and traction capabilities of studded snow tires, on wet or dry surfaces, may be poorer than that of non-studded snow tires.

All-wheel drive (AWD) models



CAUTION

- **Always use tires of the same type, size, brand, construction (bias, bias-belted or radial), and tread pattern on all four wheels. Failure to do so may result in a circumference difference between tires on the front and rear axles which will cause excessive tire wear and may damage the transmission, transfer case and differential gears.**
- **ONLY use spare tires specified for the AWD model.**

If excessive tire wear is found, it is recommended that all four tires be replaced with tires of the same size, brand, construction and tread pattern. The tire pressure and wheel alignment should also be checked and corrected as necessary. Contact an INFINITI dealer.

Tire chains must be installed only on the rear wheels and not on the front wheels.

Do not drive with tire chains on paved roads which are clear of snow. Driving

with chains in such conditions can cause damage to the various mechanisms of the vehicle due to some overstress.

TIRE CHAINS

Use of tire chains may be prohibited according to location. Check the local laws before installing tire chains. When installing tire chains, make sure they are the proper size for the tires on your vehicle and are installed according to the chain manufacturer's suggestions. **Use only SAE class "S" chains.** Class "S" chains are used on vehicles with restricted tire to vehicle clearance. Vehicles that can use Class "S" chains are designed to meet the minimum clearances between the tire and the closest vehicle suspension or body component required to accommodate the use of a winter traction device (tire chains or cables). The minimum clearances are determined using the factory equipped tires. Other types may damage your vehicle. Use chain tensioners when recommended by the tire chain manufacturer to ensure a tight fit. Loose end links of the tire chain must be secured or removed to prevent the possibility of whipping action damage to the fenders or underbody. If possible, avoid fully loading your vehicle when using tire chains. In addition, drive at a reduced

speed. Otherwise, your vehicle may be damaged and/or vehicle handling and performance may be adversely affected.

Tire chains must be installed only on the rear wheels and not on the front wheels.

Never install tire chains on a TEMPORARY USE ONLY spare tire.

Do not use the chains on dry roads. Driving with chains in such conditions can cause damage to the various mechanisms of the vehicle due to some overstress.

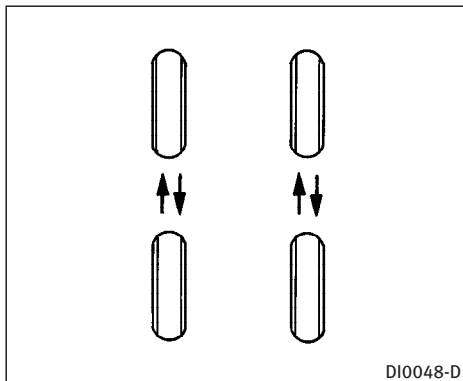

Sedan

CHANGING WHEELS AND TIRES

Tire rotation (Sedan)

INFINITI recommends rotating the tires every 7,500 miles (12,000 km).

See “Flat tire” in the “6. In case of emergency” section for tire replacing procedures.

As soon as possible, tighten the wheel nuts to the specified torque with a torque wrench.

**Wheel nut tightening torque:
80 ft-lb (108 N·m)**

The wheel nuts must be kept tightened to specification at all times. It is recommended that wheel nuts be tightened to specification at each tire rotation interval.



WARNING

- After rotating the tires, check and adjust the tire pressure.
- Retighten the wheel nuts when the vehicle has been driven for 600 miles (1,000 km) (also in cases of a flat tire, etc.).
- Do not include the T-type spare tire or any other small size spare tire in the tire rotation.
- For additional information regarding tires, refer to “Important Tire Safety Information” (US) or “Tire Safety Information” (Canada) in the Warranty Information Booklet.

Tire rotation (Coupe)

Tires cannot be rotated on this vehicle, as front tires are a different size from

rear tires and the direction of the wheel rotation is fixed for each tire.

A pin is on the front brake rotor to prevent the rear wheels from being installed in place of the front wheels. The spare tire can be installed in place of the front and rear wheels. When installing the spare tire in the front wheel, the hole in the spare tire wheel must be aligned with the pin on the brake rotor.



WARNING

- Retighten the wheel nuts when the vehicle has been driven for 600 miles (1,000 km) (also in cases of a flat tire, etc.).
- For additional information regarding tires, refer to “Important Tire Safety Information” (US) or “Tire Safety Information” (Canada) in the Warranty Information Booklet.

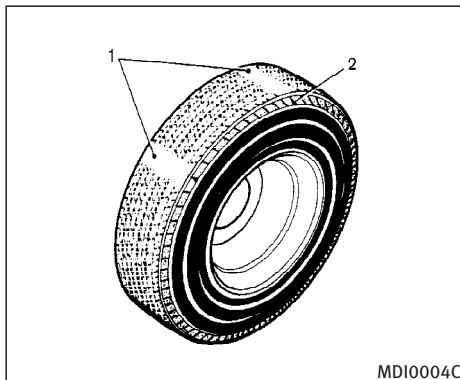

1. Wear indicator
2. Location mark

Tire wear and damage



WARNING

- Tires should be periodically inspected for wear, cracking, bulging or objects caught in the tread. If excessive wear, cracks, bulging or deep cuts are found, the tire(s) should be replaced.

- The original tires have built-in tread wear indicators. When the wear indicators are visible, the tire(s) should be replaced.
- Tires degrade with age and use. Have tires, including the spare, over 6 years old checked by a qualified technician because some tire damage may not be obvious. Replace the tires as necessary to prevent tire failure and possible personal injury.
- Improper service of the spare tire may result in serious personal injury. If it is necessary to repair the spare tire, contact an INFINITI dealer.
- For additional information regarding tires, refer to “Important Tire Safety Information” (US) or “Tire Safety Information” (Canada) in the Warranty Information Booklet.

Replacing wheels and tires

When replacing a tire, use the same size, speed rating and load carrying capacity as originally equipped. See “Specifica-

tions” in the “9. Technical and consumer information” section for recommended types and sizes of tires and wheels.



WARNING

- The use of tires other than those recommended or the mixed use of tires of different brands, construction (bias, bias-belted or radial), or tread patterns can adversely affect the ride, braking, handling, ground clearance, body-to-tire clearance, tire chain clearance, speedometer calibration, headlight aim and bumper height. Some of these effects may lead to accidents and could result in serious personal injury.
- If the wheels are changed for any reason, always replace with wheels which have the same off-set dimension. Wheels of a different off-set could cause premature tire wear, degrade vehicle handling characteristics and/or interference with the brake discs. Such interference can lead to decreased braking efficiency and/or early brake pad wear.
- When a spare tire is mounted or a wheel is replaced, tire pressure will not be indicated, the TPMS will not function and the

low tire pressure warning light will flash. Contact your INFINITI dealer as soon as possible for tire replacement and/or system resetting.

- Replacing tires with those not originally specified by INFINITI could affect the proper operation of the TPMS.
- Do not install a deformed wheel or tire even if it has been repaired. Such wheels or tires could have structural damage and could malfunction without warning.
- The use of retread tires is not recommended.
- For additional information regarding tires, refer to “Important Tire Safety Information” (US) or “Tire Safety Information” (Canada) in the Warranty Information Booklet.



CAUTION

Always use tires of the same type, size, brand, construction (bias, bias-belted or radial), and tread pattern on all four wheels. Failure to do so may result in a circumference

difference between tires on the front and rear axles which will cause excessive tire wear and may damage the transmission, transfer case and differential gears (AWD models).

Wheel balance

Unbalanced wheels may affect vehicle handling and tire life. Even with regular use, wheels can get out of balance. Therefore, they should be balanced as required.

Wheel balance service should be performed with the wheels off the vehicle. Spin balancing the wheels on the vehicle could lead to transmission damage.

For additional information regarding tires, refer to “Important Tire Safety Information” (US) or “Tire Safety Information” (Canada) in the INFINITI Warranty Information Booklet.

Care of wheels

- Wash the wheels when washing the vehicle to maintain their appearance.
- Clean the inner side of the wheels when the wheel is changed or the underside of the vehicle is washed.

- Do not use abrasive cleaners when washing the wheels.
- Inspect wheel rims regularly for dents or corrosion. Such damage may cause loss of pressure or poor seal at the tire bead.
- INFINITI recommends that the road wheels be waxed to protect against road salt in areas where it is used during winter.

Spare tire (TEMPORARY USE ONLY spare tire (T-type))

Observe the following precautions if the T-type spare tire must be used, otherwise your vehicle could be damaged or involved in an accident.



CAUTION

- The T-type spare tire should be used only for an emergency. It should be replaced by a standard tire at the first opportunity.
- Drive carefully while the T-type spare tire is installed.

Avoid sharp turns and abrupt braking while driving.

- Periodically check the T-type spare tire inflation pressure, and always keep it at 60 psi (420 kPa, 4.2 bar).
- With the T-type spare tire installed, do not drive your vehicle at speeds faster than 50 MPH (80 km/h).
- When driving on roads covered with snow or ice, the T-type spare tire should be used on the front wheel and the original tire used on the rear wheels (drive wheels). Use tire chains only on the rear two original tires (Sedan).
- Tire tread of the T-type spare tire will wear at a faster rate than the original tire. Replace the T-type spare tire as soon as the tread wear indicators appear.
- Do not use the T-type spare tire on other vehicles.
- Do not use more than one T-type spare tire at the same time.
- Do not tow a trailer while the T-type spare tire is installed.



CAUTION

- Do not use tire chains on a T-type spare tire. Tire chains will not fit properly on the T-type spare tire and may cause damage to the vehicle.
- Because the T-type spare tire is smaller than the original tire, ground clearance is reduced. To avoid damage to the vehicle do not drive over obstacles. Also do not drive the vehicle through an automatic car wash since it may get caught.

9 Technical and consumer information

Capacities and recommended fuel/lubricants ...	9-2	Installing front license plate.....	9-13
Fuel recommendation	9-3	Vehicle loading information	9-14
Engine oil and oil filter recommendation	9-5	Terms	9-14
Recommended SAE viscosity number	9-6	Vehicle load capacity	9-15
Air conditioning system refrigerant and lubricant recommendations	9-7	Loading tips.....	9-17
Specifications.....	9-8	Measurements of weights	9-17
Engine.....	9-8	Towing a trailer.....	9-18
Wheels and tires	9-9	Maximum load limits	9-18
Dimensions and weights	9-9	Towing load/specification chart	9-19
When traveling or registering your vehicle in another country	9-10	Towing safety	9-19
Vehicle identification	9-10	Flat towing	9-22
Vehicle identification number (VIN) plate... ..	9-10	Uniform tire quality grading.....	9-23
Vehicle identification number (Chassis number).....	9-10	Emission control system warranty	9-24
Engine serial number	9-11	Reporting safety defects (US only).....	9-24
F.M.V.S.S./C.M.V.S.S. certification label	9-11	Readiness for inspection/maintenance (I/M) test (US only).....	9-25
Emission control information label.....	9-12	Event data recorders	9-26
Tire and loading information label	9-12	Owner's Manual/Service Manual order information	9-26
Air conditioner specification label.....	9-13	In the event of a collision.....	9-27

CAPACITIES AND RECOMMENDED FUEL/LUBRICANTS

The following are approximate capacities. The actual refill capacities may be slightly different. When refilling, follow the procedure instructed in the “8. Maintenance and do-it-yourself” section to determine the proper refill capacity.

	Capacity (Approximate)			Recommended specifications
	US measure	Imp measure	Liter	
Fuel*1	20 gal	16-5/8 gal	76	
Engine oil (Drain and refill)*8				
With oil filter change	5 qt	4-1/8 qt	4.7	<ul style="list-style-type: none"> • API Certification Mark*2, *3 • API grade SG/SH, Energy Conserving I & II or API grade SJ or SL, Energy Conserving*2, *3 • ILSAC grade GF-I, GF-II & GF-III*2, *3
Without oil filter change	4-5/8 qt	3-7/8 qt	4.4	
Cooling system				
With reservoir	9-1/4 qt	7-5/8 qt	8.7	Genuine NISSAN Long Life Antifreeze/Coolant or equivalent
Reservoir	7/8 qt	3/5 qt	0.8	
Automatic transmission fluid	—	—	—	Genuine NISSAN Matic J ATF*4
Manual transmission gear oil	—	—	—	Genuine NISSAN Manual Transmission Fluid (MTF) HQ Multi 75W-85 or API GL-4, Viscosity SAE 75W-85 or 75W-90
Differential gear oil	—	—	—	API GL-5, Viscosity SAE 80W-90*5
Transfer fluid	—	—	—	Genuine NISSAN Matic D ATF (Continental U.S. and Alaska) or CANADA NISSAN Automatic Transmission Fluid*6
Power steering fluid (PSF)	Refill to the proper fluid level according to the instructions in the “8. Maintenance and do-it-yourself” section.			Genuine NISSAN PSF or equivalent*10
Brake and clutch fluid	—	—	—	Genuine NISSAN Super Heavy Duty Brake Fluid*7 or equivalent DOT 3
Multi-purpose grease	—	—	—	NLGI No. 2 (Lithium soap base)
Air conditioning system refrigerant	—	—	—	HFC-134a (R-134a)*9
Air conditioning system lubricants	—	—	—	NISSAN A/C System Oil Type S or exact equivalent
Windshield washer fluid	—	—	—	Genuine NISSAN Windshield Washer Concentrate Cleaner & Antifreeze or equivalent

*1: For additional information, see “Fuel recommendation” later in this section.

*2: For additional information, see “Engine oil and oil filter recommendation” later in this section.

*3: For additional information, see “Recommended SAE viscosity number” later in this section.

***4: Using automatic transmission fluid other than Genuine NISSAN Matic J ATF will cause deterioration in driveability and automatic transmission durability, and may damage the automatic transmission, which is not covered by the INFINITI new vehicle limited warranty.**

*5: For hot climates, viscosity SAE 90 is suitable for ambient temperatures always above 32°F (0°C).

*6: DEXRON^{III}/MERCON^{III} or equivalent may also be used. Outside the continental United States and Alaska contact an INFINITI dealer for more information regarding suitable fluids, including recommended brand(s) of DEXRON^{III}/MERCON^{III} automatic transmission fluid.

*7: Available in mainland US through an INFINITI dealer.

*8: For additional information, see “Engine oil” in the “8. Maintenance and do-it-yourself” section for changing engine oil.

*9: For additional information, see “Vehicle identification” later in this section for air conditioner specification label.

*10: For Canada, NISSAN Automatic Transmission Fluid (ATF), DEXRON^{III}/MERCON^{III} or equivalent ATF may also be used.

9-2 Technical and consumer information

FUEL RECOMMENDATION

Sedan — Automatic transmission models

Use unleaded regular gasoline with an octane rating of at least 87 AKI (Anti-Knock Index) number (Research octane number 91).

For improved vehicle performance, INFINITI recommends the use of unleaded premium gasoline with an octane rating of at least 91 AKI number (Research octane number 96).

Sedan — Manual transmission and Coupe models

Use unleaded premium gasoline with an octane rating of at least 91 AKI (Anti-Knock Index) number (Research octane number 96).

If premium gasoline is not available, unleaded regular gasoline with an octane rating of 87 AKI number (Research octane number 91) may be temporarily used, but only under the following precautions:

- Have the fuel tank filled only partially with unleaded regular gasoline, and fill up with unleaded premium gasoline as soon as possible.

- Avoid full throttle driving and abrupt acceleration.

However, for maximum vehicle performance, the use of unleaded premium gasoline is recommended.



CAUTION

- **Using a fuel other than that specified could adversely affect the emission control system, and may also affect the warranty coverage.**
- **Under no circumstances should a leaded gasoline be used, because this will damage the three-way catalyst.**
- **Do not use E-85 fuel in your vehicle. Your vehicle is not designed to run on E-85 fuel. Using E-85 fuel can damage the fuel system components and is not covered by the INFINITI vehicle limited warranty.**

Gasoline specifications

INFINITI recommends using gasoline that meets the World-Wide Fuel Charter (WWFC) specifications where it is avail-

able. Many of the automobile manufacturers developed this specification to improve emission control system and vehicle performance. Ask your service station manager if the gasoline meets the WWFC specifications.

Reformulated gasoline

Some fuel suppliers are now producing reformulated gasolines. These gasolines are specially designed to reduce vehicle emissions. INFINITI supports efforts towards cleaner air and suggests that you use reformulated gasoline when available.

Gasoline containing oxygenates

Some fuel suppliers sell gasoline containing oxygenates such as ethanol, MTBE and methanol with or without advertising their presence. INFINITI does not recommend the use of fuels of which the oxygenate content and the fuel compatibility for your INFINITI cannot be readily determined. If in doubt, ask your service station manager.

If you use oxygenate-blend gasoline, please take the following precautions as the usage of such fuels may cause vehicle

performance problems and/or fuel system damage.

- **The fuel must be unleaded and have an octane rating no lower than that recommended for unleaded gasoline.**
- **If an oxygenate-blend, excepting a methanol blend, is used, it should contain no more than 10% oxygenate. (MTBE may, however, be added up to 15%.)**
- **If a methanol blend is used, it should contain no more than 5% methanol (methyl alcohol, wood alcohol). It should also contain a suitable amount of appropriate cosolvents and corrosion inhibitors. If not properly formulated with appropriate cosolvents and corrosion inhibitors, such methanol blends may cause fuel system damage and/or vehicle performance problems. At this time, sufficient data is not available to ensure that all methanol blends are suitable for use in INFINITI vehicles.**

If any driveability problems such as engine stalling and hard hot starting are experienced after using oxygenate-blend fuels, immediately change to a non-oxygenate fuel or a fuel with a low blend of MTBE.

9-4 Technical and consumer information

Take care not to spill gasoline during refueling. Gasoline containing oxygenates can cause paint damage.

E-85 fuel

E-85 fuel is a mixture of approximately 85% fuel ethanol and 15% unleaded gasoline. E-85 can only be used in a Flexible Fuel Vehicle (FFV). Do not use E-85 fuel in your vehicle. U.S. government regulations require fuel ethanol dispensing pumps to be identified by a small, square, orange and black label with the common abbreviation or the appropriate percentage for that region.

Aftermarket fuel additives

INFINITI does not recommend the use of any aftermarket fuel additives (i.e. fuel injector cleaner, octane booster, intake valve deposit removers, etc.) which are sold commercially. Many of these additives intended for gum, varnish or deposit removal may contain active solvent or similar ingredients that can be harmful to the fuel system and engine.

Octane rating tips

Using unleaded gasoline with an octane rating lower than recommended can cause

persistent, heavy spark knock. (Spark knock is a metallic rapping noise.) If severe, this can lead to engine damage. If you detect a persistent heavy spark knock even when using gasoline of the stated octane rating, or if you hear steady spark knock while holding a steady speed on level roads, have your dealer correct the condition. Failure to correct the condition is misuse of the vehicle, for which INFINITI is not responsible.

Incorrect ignition timing will result in knocking, after-run or overheating. This in turn may cause excessive fuel consumption or damage to the engine. If any of the above symptoms are encountered, have your vehicle checked at an INFINITI dealer or other competent service facility.

However, now and then you may notice light spark knock for a short time while accelerating or driving up hills. This is no cause for concern, because you get the greatest fuel benefit when there is light spark knock for a short time under heavy engine load.

API certification mark



API service symbol

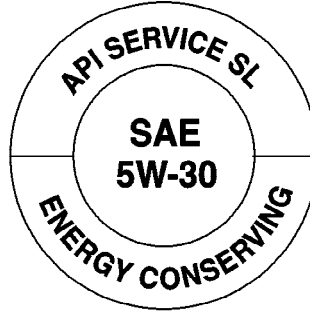

STI0367

ENGINE OIL AND OIL FILTER RECOMMENDATION

Selecting the correct oil

It is essential to choose the correct grade, quality and viscosity engine oil to ensure satisfactory engine life and performance. See “Capacities and recommended fuel/lubricants” earlier in this section. INFINITI recommends the use of an energy conserving oil in order to improve fuel economy.

Select only engine oils that meet the American Petroleum Institute (API) certifi-

cation or International Lubricant Standardization and Approval Committee (ILSAC) certification and SAE viscosity standard. These oils have the API certification mark on the front of the container. Oils which do not have the specified quality label should not be used as they could cause engine damage.

Oil additives

INFINITI does not recommend the use of oil additives. The use of an oil additive is not necessary when the proper oil type is used and maintenance intervals are followed.

Oil which may contain foreign matter or has been previously used should not be used.

Oil viscosity

The engine oil viscosity or thickness changes with temperature. Because of this, it is important that the engine oil viscosity be selected based on the temperatures at which the vehicle will be operated before the next oil change. The recommended SAE viscosity number chart shows the recommended oil viscosities for the expected ambient temperatures. Choosing an oil viscosity other than that recommended could cause serious engine damage.

Selecting the correct oil filter

Your new vehicle is equipped with a high-quality genuine NISSAN oil filter. When replacing, use the genuine oil filter or its equivalent for the reason described in change intervals.

Change intervals

The oil and oil filter change intervals for your engine are based on the use of the specified quality oils and filters. Oil and filter other than the specified quality, or oil and filter change intervals longer than recommended could reduce engine life. Damage to engines caused by improper maintenance or use of incorrect oil and filter quality and/or viscosity is not covered by the new INFINITI vehicle limited warranties.

Your engine was filled with a high quality engine oil when it was built. You do not have to change the oil before the first recommended change interval. Oil and filter change intervals depend upon how you use your vehicle. Operation under the following conditions may require more frequent oil and filter changes.

- repeated short distance driving at cold outside temperatures

- driving in dusty conditions
- extensive idling
- towing a trailer
- stop and go commuting

Refer to the “INFINITI Service and Maintenance Guide” for the maintenance schedule.

9-6 Technical and consumer information

RECOMMENDED SAE VISCOSITY NUMBER

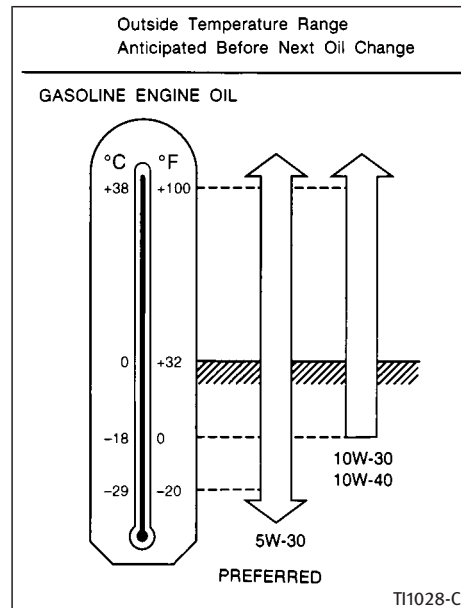

SAE 5W-30 viscosity oil is preferred for all ambient temperatures. SAE 10W-30, 10W-40 viscosity oil may be used if the ambient temperature is above 0°F (-18°C).

AIR CONDITIONING SYSTEM REFRIGERANT AND LUBRICANT RECOMMENDATIONS

The air conditioning system in this INFINITI vehicle must be charged with the refrigerant HFC-134a (R-134a) and the lubricant, Nissan A/C System Oil Type S or the exact equivalents.



CAUTION

The use of any other refrigerant or lubricant will cause severe damage to the air conditioning system and will require the replacement of all air conditioner system components.

The refrigerant HFC-134a (R-134a) in your INFINITI vehicle will not harm the earth's ozone layer. Although this refrigerant does not affect the earth's atmosphere, certain governmental regulations require the recovery and recycling of any refrigerant during automotive air conditioning system service. An INFINITI dealer has the trained technicians and equipment needed to recover and recycle your air conditioning system refrigerant.

Contact an INFINITI dealer when servicing your air conditioning system.

SPECIFICATIONS

ENGINE

	Model	VQ35DE
Type		Gasoline, 4-cycle
Cylinder arrangement		6-cylinder, V-slanted at 60°
Bore x Stroke	in (mm)	3.760 x 3.205 (95.5 x 81.4)
Displacement	cu in (cm ³)	213.45 (3,498)
Firing order		1-2-3-4-5-6*
Idle speed	rpm	
Ignition timing (B.T.D.C.)	degree/rpm	See the emission control label on the underside of the hood.
CO percentage at idle speed	[No air] %	
Spark plug	Standard	PLFR5A-11
	Service option	PLFR4A-11, PLFR6A-11
Spark plug gap (Normal)	in (mm)	0.043 (1.1)
Camshaft operation		Timing chain

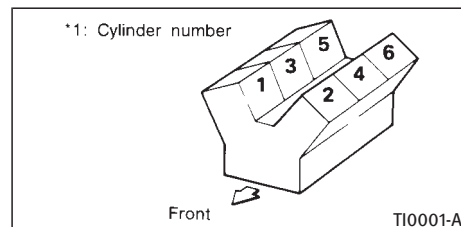

The spark ignition system of this vehicle meets all requirements of the Canadian Interference-Causing Equipment Regulations.

WHEELS AND TIRES

Road wheel

	Type	Position	Size	Offset in (mm)
Sedan	Aluminum	—	17 x 7J	1.77 (45)
		—	18 x 7-1/2J	1.77 (45)
Coupe	Aluminum	Front	17 x 7-1/2J	1.18 (30)
		Rear	17 x 8J	1.30 (33)
		Front	18 x 8J	1.18 (30)
		Rear	18 x 8J	1.18 (30)
		Front	19 x 8J	1.18 (30)
		Rear	19 x 8-1/2J	1.30 (33)

Tire

	Type	Position	Size	Pressure (Cold)
Sedan	Conventional	—	P215/55R17 93V	210 kPa (30 psi)
		—	235/45R18 94W	230 kPa (33 psi)
	Spare	—	T145/80D17	420 kPa (60 psi)
Coupe	Conventional	Front	P225/50R17 93V	210 kPa (30 psi)
		Rear	P235/50R17 95V	210 kPa (30 psi)
		Front	225/45R18 91W	240 kPa (35 psi)
		Rear	245/45R18 96W	240 kPa (35 psi)
		Front	225/40R19 89Y	240 kPa (35 psi)
		Rear	245/40R19 94Y	240 kPa (35 psi)
	Spare	—	T145/80D17	420 kPa (60 psi)

*1: Option for USA, conventional for Canada (for models with tire size P215/55R17 93V)

DIMENSIONS AND WEIGHTS

		Sedan	Coupe
Overall length	in (mm)	186.9 (4,747)	182.2 (4,628)
Overall width	in (mm)	69.0 (1,753)	71.5 (1,815)
Overall height	in (mm)	57.7 (1,467)*1	54.8 (1,393)
		58.4 (1,484)*2	55.1 (1,399)*3
Front tread	in (mm)	59.1 (1,500)*1	60.4 (1,535)
		59.3 (1,505)*2	
Rear tread	in (mm)	59.3 (1,505)	60.6 (1,540)*4
			60.8 (1,545)*5
Wheelbase	in (mm)	112.2 (2,850)	112.2 (2,850)
Gross vehicle weight rating	lb (kg)		
Gross axle weight rating		See the F.M.V.S.S./C.M.V.S.S. certification label on the driver's side lock pillar.	
Front	lb (kg)		
Rear	lb (kg)		

*1: For 2WD models

*2: For AWD models

*3: For 18 in and 19 in road wheel models

*4: For models with road wheel size — 17 x 8J and 19 x 8-1/2J [offset 1.30 in (33 mm)]

*5: For models with road wheel size — 18 x 8J [offset 1.18 in (30 mm)]

WHEN TRAVELING OR REGISTERING YOUR VEHICLE IN ANOTHER COUNTRY

When planning to travel in another country, you should first find out if the fuel available is suitable for your vehicle's engine.

Using fuel with too low an octane rating may cause engine damage. All gasoline vehicles must be operated with unleaded engine gasoline. Therefore, avoid taking your vehicle to areas where appropriate fuel is not available.

When transferring the registration of your vehicle to another country, state, province or district, it may be necessary to modify the vehicle to meet local laws and regulations.

The laws and regulations for motor vehicle emission control and safety standards vary according to the country, state, province or district; therefore, vehicle specifications may differ.

When any vehicle is to be taken into another country, state, province or district and registered, its modifications, transportation, and registration are the responsibility of the user. INFINITI is not responsible for any inconvenience that may result.

VEHICLE IDENTIFICATION

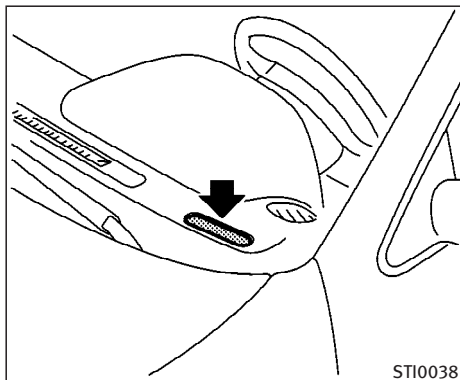

VEHICLE IDENTIFICATION NUMBER (VIN) PLATE

The vehicle identification number plate is attached as shown. This number is the identification for your vehicle and is used in the vehicle registration.

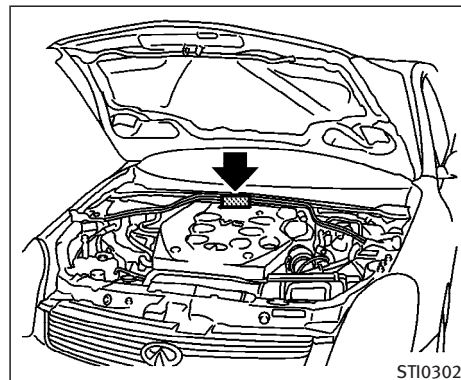

VEHICLE IDENTIFICATION NUMBER (Chassis number)

The number is stamped as shown.

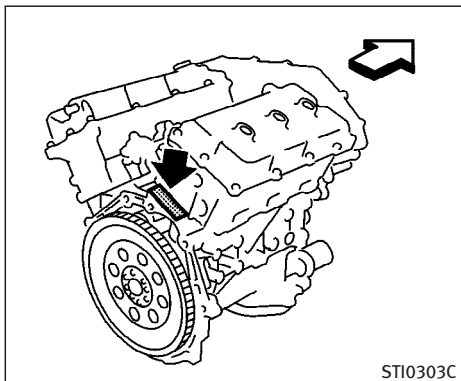

ENGINE SERIAL NUMBER

The number is stamped on the engine as shown.

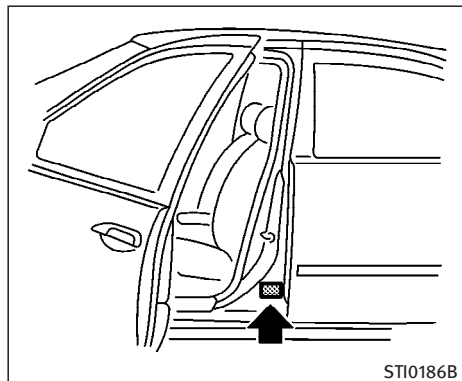

Sedan

F.M.V.S.S./C.M.V.S.S. CERTIFICATION LABEL

The Federal Motor Vehicle Safety Standards (F.M.V.S.S.) or Canadian Motor Vehicle Safety Standards (C.M.V.S.S.) certification label is affixed as shown. This label contains valuable vehicle information, such as: Gross Vehicle Weight Ratings (GVWR), Gross Axle Weight Rating (GAWR), month and year of manufacture, Vehicle Identification Number (VIN), etc. Review it carefully.

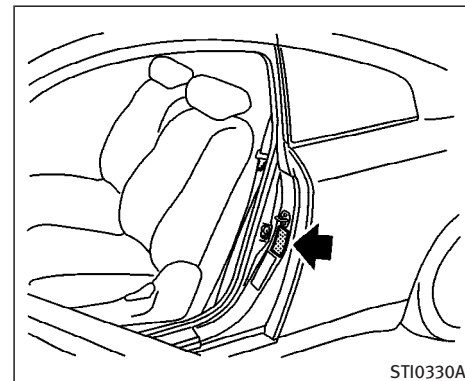

Coupe

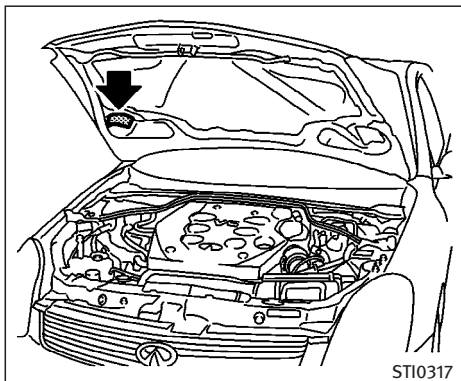

EMISSION CONTROL INFORMATION LABEL

The emission control information label is attached as shown.

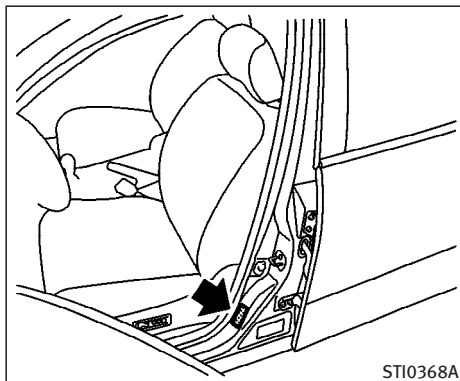

Sedan

TIRE AND LOADING INFORMATION LABEL

The cold tire pressures are shown on the Tire and Loading Information label affixed to the driver side center pillar.

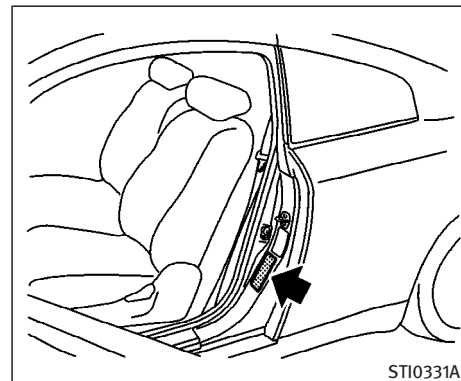

Coupe

INSTALLING FRONT LICENSE PLATE

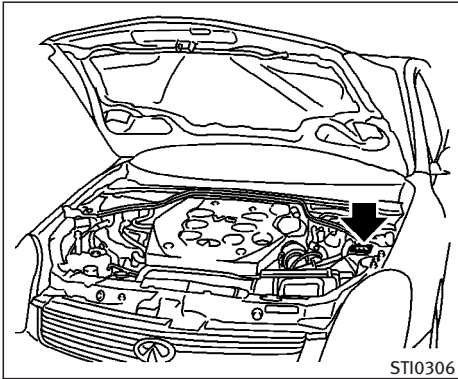

AIR CONDITIONER SPECIFICATION LABEL

The air conditioner specification label is affixed inside of the hood as shown.

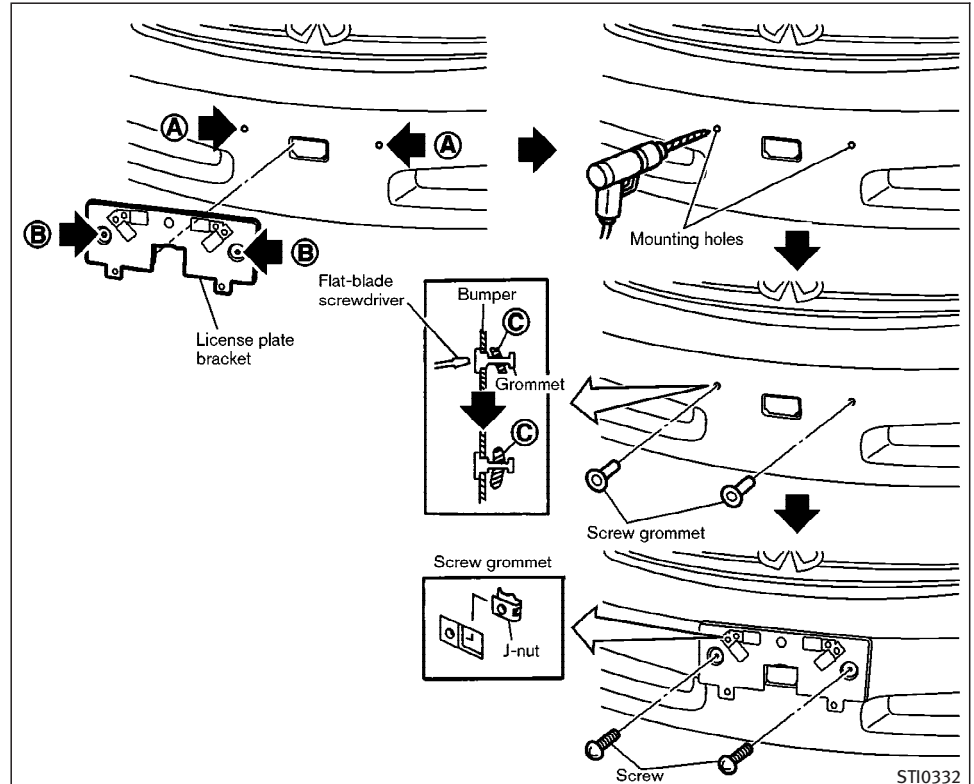

Use the following steps to mount the license plate:

Before mounting the license plate, confirm that the following parts are enclosed in the vinyl bag.

- License plate bracket
- J-nut x 2
- Screw x 2
- Screw grommet x 2

1. Temporarily place the license plate bracket and mark the pilot hole points **(A)** using holes **(B)** while aligning the towing hook hole of the front bumper fascia.
2. Remove the license plate bracket.
3. Carefully drill two pilot holes **(A)** using a 0.39 in (10 mm) drill bit at the marked locations. **(Be sure that the drill only goes through the fascia, or damage to the nut may occur.)**
4. Insert grommets into the hole on the fascia.
5. Insert a flat-blade screwdriver into the grommet hole to turn part **(C)** 90 degrees.

9-14 Technical and consumer information

6. Insert a J-nut into the license plate bracket before placing the license plate bracket on the fascia.
7. Install the license plate bracket with screws.
8. Install the license plate with bolts that are no longer than 0.55 in (14 mm).

VEHICLE LOADING INFORMATION



WARNING

- **It is extremely dangerous to ride in a cargo area inside of a vehicle. In a collision, people riding in these areas are more likely to be seriously injured or killed.**
- **Do not allow people to ride in any area of your vehicle that is not equipped with seats and seat belts.**
- **Be sure everyone in your vehicle is in a seat and using a seat belt properly.**

TERMS

It is important to familiarize yourself with the following terms before loading your vehicle:

- **Curb Weight** (actual weight of your vehicle) - vehicle weight including: standard and optional equipment, fluids, emergency tools, and spare

tire assembly. This weight **does not** include passengers and cargo.

- GVW (Gross Vehicle Weight) - curb weight plus the combined weight of passengers and cargo.
- GVWR (Gross Vehicle Weight Rating) - maximum total combined weight of the unloaded vehicle, passengers, luggage, hitch, trailer tongue load and any other optional equipment. This information is located on the F.M.V.S.S./C.M.V.S.S. label.
- GAWR (Gross Axle Weight Rating) - maximum weight (load) limit specified for the front or rear axle. This information is located on the F.M.V.S.S./C.M.V.S.S. label.
- GCWR (Gross Combined Weight Rating) - maximum total weight rating of the vehicle, passengers, cargo and trailer.

- Vehicle Capacity Weight, Load limit, Total load capacity - maximum total weight limit specified of the load (passengers and cargo) for the vehicle. This is the maximum combined weight of occupants and cargo that can be loaded into the vehicle. If the vehicle is used to tow a trailer, the trailer tongue weight must be included as part of the cargo load. This information is located on the Tire and Loading Information label.
- Cargo capacity - permissible weight of cargo, the subtracted weight of occupants from the load limit.

VEHICLE LOAD CAPACITY

Do not exceed the load limit of your vehicle shown as “The combined weight of occupants and cargo” on the Tire and Loading Information label. Do not exceed the number of occupants shown as “Seating Capacity” on the Tire and Loading Information label.

To get “the combined weight of occupants and cargo”, add the weight of all occupants, then add the total luggage weight to the value. Examples are shown in the following illustration.

Example

$$\begin{array}{l} \text{Load limit} \\ 1,400 \text{ lb} \\ (640 \text{ kg}) \end{array} - \left(\begin{array}{l} \text{Occupants} \\ \text{Luggage} \\ \text{Trailer Tongue} \\ \text{Weight} \end{array} \right) = \begin{array}{l} \text{Remaining available} \\ \text{cargo and luggage} \\ \text{load capacity} = \\ 740 \text{ lb} \\ (336 \text{ kg}) \end{array}$$

$150 \text{ lb} \times 2 = 300 \text{ lb}$ $30 \text{ lb} \times 2 = 60 \text{ lb}$ 300 lb
(70 kg) (135 kg) (14 kg) (27 kg) (135 kg)

$$\begin{array}{l} \text{Load limit} \\ 1,400 \text{ lb} \\ (640 \text{ kg}) \end{array} - \left(\begin{array}{l} \text{Occupants} \\ \text{Luggage} \end{array} \right) = \begin{array}{l} \text{Remaining available} \\ \text{cargo and luggage} \\ \text{load capacity} = \\ 1,040 \text{ lb} \\ (472 \text{ kg}) \end{array}$$

$150 \text{ lb} \times 2 = 300 \text{ lb}$ $30 \text{ lb} \times 2 = 60 \text{ lb}$
(70 kg) (135 kg) (14 kg) (27 kg)

$$\begin{array}{l} \text{Load limit} \\ 1,400 \text{ lb} \\ (640 \text{ kg}) \end{array} - \left(\begin{array}{l} \text{Occupants} \\ \text{Luggage} \end{array} \right) = \begin{array}{l} \text{Remaining available} \\ \text{cargo and luggage} \\ \text{load capacity} = \\ 500 \text{ lb} \\ (227 \text{ kg}) \end{array}$$

$150 \text{ lb} \times 5 = 750 \text{ lb}$ $30 \text{ lb} \times 5 = 150 \text{ lb}$
(70 kg) (340 kg) (14 kg) (70 kg)

STI0445

Steps for determining correct load limit

1. Locate the statement “The combined weight of occupants and cargo should never exceed XXX kg or XXX lbs” on your vehicle’s placard.
2. Determine the combined weight of the driver and passengers that will be riding in your vehicle.
3. Subtract the combined weight of the driver and passengers from XXX kg or XXX lbs.
4. The resulting figure equals the available amount of cargo and luggage load capacity. For example, if the XXX amount equals 1,400 lbs. and there will be five 150 lb. passengers in your vehicle, the amount of available cargo and luggage load capacity is 650 lbs. ($1400 - 750$ (5×150) = 650 lbs.) or ($640 - 340$ (5×70) = 300 kg.)
5. Determine the combined weight of luggage and cargo being loaded on

the vehicle. That weight may not safely exceed the available cargo and luggage load capacity calculated in Step 4.

6. If your vehicle will be towing a trailer, load from your trailer will be transferred to your vehicle. Consult this manual to determine how this reduces the available cargo and luggage load capacity of your vehicle.

Before driving a loaded vehicle, confirm that you do not exceed the Gross Vehicle Weight Rating (GVWR) or the Gross Axle Weight Rating (GAWR) for your vehicle. See “Measurement of Weights” later in this section.

Also check tires for proper inflation pressures. See the Tire and Loading Information label.

LOADING TIPS

- The GVW must not exceed GVWR or GAWR as specified on the

F.M.V.S.S./C.M.V.S.S. certification label.

- Do not load the front and rear axle to the GAWR. Doing so will exceed the GVWR.



WARNING

- **Properly secure all cargo with ropes or straps to help prevent it from sliding or shifting. Do not place cargo higher than the seatbacks. In a sudden stop or collision, unsecured cargo could cause personal injury.**
- **Do not load your vehicle any heavier than the GVWR or the maximum front and rear GAWRs. If you do, parts of your vehicle can break, tire damage could occur, or it can change the way your vehicle handles. This could result in loss of control and cause personal injury.**

- **Overloading not only can shorten the life of your vehicle and the tire, but can also cause unsafe vehicle handling and longer braking distances. This may cause a premature tire failure which could result in a serious accident and personal injury. Failures caused by overloading are not covered by the vehicle's warranty.**

MEASUREMENT OF WEIGHTS

Secure loose items to prevent weight shifts that could affect the balance of your vehicle. When the vehicle is loaded, drive to a scale and weigh the front and the rear wheels separately to determine axle loads. Individual axle loads should not exceed either of the gross axle weight ratings (GAWR). The total of the axle loads should not exceed the gross vehicle weight rating (GVWR). These ratings are given on the vehicle certification label. If weight ratings are exceeded, move or remove items to bring all weights below the ratings.

TOWING A TRAILER

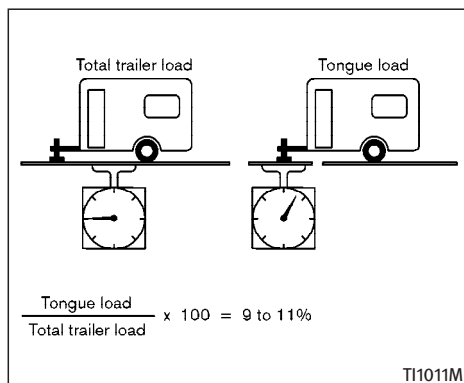

WARNING

Overloading or improper loading of a trailer and its cargo can adversely affect vehicle handling, braking and performance and may lead to accidents.



CAUTION

- Do not tow a trailer or haul a heavy load for the first 500 miles (800 km).

Your engine, axle or other parts could be damaged.

- For the first 500 miles (800 km) that you tow a trailer, do not drive over 50 mph (80 km/h) and do not make starts at full throttle. This helps the engine and other parts of your vehicle wear in at the heavier loads.

Your new vehicle was designed to be used primarily to carry passengers and cargo. Remember that towing a trailer will place additional loads on a vehicle's engine, drive train, steering, braking and other systems.

An INFINITI Towing Guide (U.S. only) is available on the website at www.infiniti.com. This guide includes information on trailer towing capability and the special equipment required for proper towing.

MAXIMUM LOAD LIMITS

Maximum trailer loads

Never allow the total trailer load to exceed the value specified in the Towing Load/Specification Chart found later in

this section. The total trailer load equals trailer weight plus its cargo weight.

Towing loads greater than specified or using improper towing equipment could adversely affect vehicle handling, braking and performance. The ability of a vehicle to tow a trailer is not only related to the maximum trailer loads, but also the places you plan to tow. Tow weights appropriate for level highway driving may have to be reduced on very steep grades or in low traction situations (for example, on slippery boat ramps).



CAUTION

Vehicle damage resulting from improper towing procedures are not covered by INFINITI warranties.

Tongue load

Keep the tongue load between 9 and 11% of the total trailer load within the maximum tongue load limits shown in the following Towing Load/Specification Chart. If the tongue load becomes excessive, rearrange cargo to allow for proper tongue load.

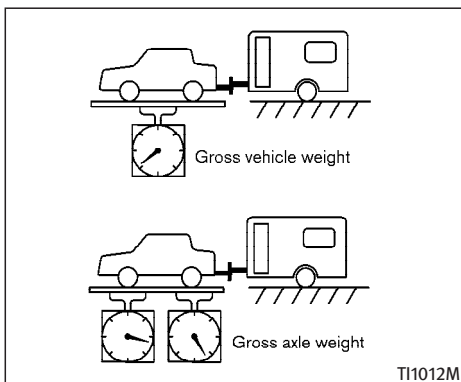

Maximum gross vehicle weight/ maximum gross axle weight

The gross vehicle weight of the towing vehicle must not exceed the gross vehicle weight rating (GVWR) shown on the F.M.V.S.S./C.M.V.S.S. certification label. The gross vehicle weight equals the combined weight of the unloaded vehicle, passengers, luggage, hitch, trailer tongue load and any other optional equipment. In addition, front or rear gross axle weight must not exceed GAWR shown on the F.M.V.S.S./C.M.V.S.S. certification label.

TOWING LOAD/SPECIFICATION CHART

TOWING LOAD/SPECIFICATION CHART Unit: lb (kg)	
MAXIMUM TOWING LOAD	1,000 (454)
MAXIMUM TONGUE LOAD	100 (45.4)

TOWING SAFETY

Trailer hitch

Choose a proper hitch for a vehicle and trailer. Make sure the trailer hitch is securely attached to the vehicle, to help avoid personal injury or property damage due to sway caused by crosswinds, rough road surfaces or passing trucks.

Hitch ball

Choose a hitch ball of the proper size and weight rating for a trailer:

- The required hitch ball size is stamped on most trailer couplers. Most hitch balls also have the size printed on top of the ball.

- Choose the proper class hitch ball based on the trailer weight.
- The diameter of the threaded shank of the hitch ball must be matched to the ball mount hole diameter. The hitch ball shank should be no more than 1/16" smaller than the hole in the ball mount.
- The threaded shank of the hitch ball must be long enough to be properly secured to the ball mount. There should be at least 2 threads showing beyond the lock washer and nut.

Class I hitch

Class I trailer hitch equipment (receiver, ball mount and hitch ball) can be used to tow trailers of a maximum weight of 2,000 lb (909 kg).

You may add Class I trailer hitch equipment to the vehicle that has a 2,000 lb (909 kg) maximum weight rating, but your vehicle is only capable of towing the maximum trailer weights shown in the Towing Load/Specification Chart earlier in this section.



CAUTION

- Do not use axle-mounted hitches.
- The hitch should not be attached to or affect the operation of the impact-absorbing bumper.
- Do not modify the vehicle exhaust system, brake system, etc. to install a trailer hitch.
- To reduce the possibility of additional damage if your vehicle is struck from the rear, where practical, remove the hitch and/or receiver when not in use.
- After the hitch is removed, seal the bolt holes to prevent exhaust fumes, water or dust from entering the passenger compartment.
- Regularly check that all trailer hitch mounting bolts are securely mounted.

Tire pressures

- When towing a trailer, inflate the vehicle tires to the recommended cold tire pressure indicated on the Tire and Loading Information label.
- Trailer tire condition, size, load rating and proper inflation pressure should be in accordance with the trailer and tire manufacturers' specifications.

Safety chains

Always use a suitable chains between your vehicle and the trailer. The safety chains should be crossed and should be attached to the hitch, not to the vehicle bumper or axle. Be sure to leave enough slack in the chains to permit turning corners.

Trailer lights



CAUTION

When splicing into the vehicle electrical system, a commercially available power-type

module/converter must be used to provide power for all trailer lighting. This unit uses the vehicle battery as a direct power source for all trailer lights while using the vehicle tail light, stoplight and turn signal circuits as a signal source. The module/converter must draw no more than 15 milliamps from the stop and tail lamp circuits. Using a module/converter that exceeds these power requirements may damage the vehicle's electrical system. See a reputable trailer dealer to obtain the proper equipment and to have it installed.

Trailer lights should comply with federal and/or local regulations. For assistance in hooking up trailer lights, contact an INFINITI dealer or reputable trailer dealer.

Trailer brakes

If your trailer is equipped with a braking system, make sure it conforms to federal and/or local regulations and that it is properly installed.



WARNING

Never connect a trailer brake system directly to the vehicle brake system.

Pre-towing tips

- Be certain your vehicle maintains a level position when a loaded and/or unloaded trailer is hitched. Do not drive the vehicle if it has an abnormal nose-up or nose-down condition; check for improper tongue load, overload, worn suspension or other possible causes of either condition.
- Always secure items in the trailer to prevent load shifts while driving.
- Load the trailer so approximately 60% of the trailer load is in the front half and 40% is in the back half.
- Check your hitch, trailer tire pressure, vehicle tire pressure, trailer light operation, and trailer wheel lug nuts every time you attach a trailer to the vehicle.
- Be certain your rear view mirrors conform to all federal, state or local regula-

tions. If not, install any mirrors required for towing before driving the vehicle.

Trailer towing tips

In order to gain skill and an understanding of the vehicle's behavior, you should practice turning, stopping and backing up in an area which is free from traffic. Steering stability, and braking performance will be somewhat different than under normal driving conditions.

- Always secure items in the trailer to prevent load shift while driving.
- Avoid abrupt starts, acceleration or stops.
- Avoid sharp turns or lane changes.
- Always drive your vehicle at a moderate speed. Some states or provinces have specific speed limits for vehicles that are towing trailers. Obey the local speed limits.
- When backing up, hold the bottom of the steering wheel with one hand. Move your hand in the direction in which you want the trailer to go. Make small corrections and back up slowly. If possible, have someone guide you when you are backing up.

- Always block the wheels on both vehicle and trailer when parking. Parking on a slope is not recommended; however, if you must do so, and if your vehicle is equipped with automatic transmission, first apply the parking brake and block the wheels, and then move the transmission selector lever into the P (Park) position. If you move the selector lever to the P (Park) position before applying the parking brake and blocking the wheels, transmission damage could occur.
- When going down a hill, shift into a lower gear and use the engine braking effect. When going up a long grade, downshift the transmission to a lower gear and reduce speed to reduce chances of engine overloading and/or overheating. However, for long steep grades, do not stay in 1st or 2nd gear when driving above 35 MPH (56 km/h).
- If the engine coolant rises to an extremely high temperature when the air conditioning system is on, turn off the air conditioner. Coolant heat can be additionally vented by opening the windows, switching the fan control to high and setting the temperature control to the HOT position.

- Trailer towing requires more fuel than normal circumstances.
- Avoid towing a trailer for the first 500 miles (800 km).
- Have your vehicle serviced more often than at intervals specified in the recommended maintenance schedule in the INFINITI Service and Maintenance Guide.
- When making a turn, your trailer wheels will be closer to the inside of the turn than your vehicle wheels. To compensate for this, make a larger than normal turning radius during the turn.
- Crosswinds and rough roads will adversely affect vehicle/trailer handling, possibly causing vehicle sway. When being passed by larger vehicles, be prepared for possible changes in crosswinds that could affect vehicle handling. If swaying does occur, firmly grip the steering wheel, steer straight ahead, and immediately (but gradually) reduce vehicle speed. This combination will help stabilize the vehicle. Never increase speed.
- Be careful when passing other vehicles. Passing while towing a trailer requires considerably more distance than normal passing. Remember the length of the trailer must also pass the other vehicle before you can safely change lanes.
- To maintain engine braking efficiency and electrical charging performance, do not use sixth gear (manual transmission) or fifth position (automatic transmission).
- Avoid holding the brake pedal down too long or too frequently. This could cause the brakes to overheat, resulting in reduced braking efficiency.
- Increase your following distance to allow for greater stopping distances while towing a trailer. Anticipate stops and brake gradually.
- Do not use cruise control while towing a trailer.
- Check your hitch, trailer wiring harness connections, and trailer wheel lug nuts after 50 miles (80 km) of travel and at every break.
- When stopped in traffic for long periods of time in hot weather, put the vehicle in the P (Park) position.

When towing a trailer, transmission oil/fluid should be changed more frequently.

For additional information, see the “8. Maintenance and do-it-yourself” section earlier in this manual.

FLAT TOWING

Towing your vehicle with all four wheels on the ground is sometimes called flat towing. This method is sometimes used when towing a vehicle behind a recreational vehicle, such as a motor home.



CAUTION

- **Failure to follow these guidelines can result in severe transmission damage.**
- **Whenever flat towing your vehicle, always tow forward, never backward.**
- **DO NOT tow any automatic transmission vehicle with all four wheels on the ground (flat towing). Doing so WILL DAMAGE internal transmission parts due to lack of transmission lubrication.**

- For emergency towing procedures refer to “Towing recommended by INFINITI” in the “6. In case of emergency” section of this manual.

Automatic transmission

To tow a vehicle equipped with an automatic transmission, an appropriate vehicle dolly **MUST** be placed under the towed vehicle’s drive wheels. **Always** follow the dolly manufacturer’s recommendations when using their product.

Manual transmission

- Always tow with the manual transmission in Neutral.
- After towing 500 miles, start and idle the engine with the transmission in Neutral for two minutes. Failure to idle the engine after every 500 miles of towing may cause damage to the transmission’s internal parts.

UNIFORM TIRE QUALITY GRADING

DOT (Department Of Transportation) Quality Grades: All passenger car tires must conform to federal safety requirements in addition to these grades.

Quality grades can be found where applicable on the tire sidewall between tread shoulder and maximum section width. For example:

Treadwear 200 Traction AA Temperature A Treadwear

The treadwear grade is a comparative rating based on the wear rate of the tire when tested under controlled conditions on a specified government test course. For example, a tire graded 150 would wear one and one-half (1 1/2) times as well on the government course as a tire graded 100. The relative performance of tires depends upon the actual conditions of their use, however, and may depart significantly from the norm due to variations in driving habits, service practices and differences in road characteristics and climate.

Traction AA, A, B and C

The traction grades, from highest to lowest, are AA, A, B, and C. Those grades

represent the tire’s ability to stop on wet pavement as measured under controlled conditions on specified government test surfaces of asphalt and concrete. A tire marked C may have poor traction performance.



WARNING

The traction grade assigned to this tire is based on straight-ahead braking traction tests, and does not include acceleration, cornering, hydroplaning, or peak traction characteristics.

Temperature A, B and C

The temperature grades A (the highest), B, and C, representing the tire’s resistance to the generation of heat and its ability to dissipate heat when tested under controlled conditions on a specified indoor laboratory test wheel. Sustained high temperature can cause the material of the tire to degenerate and reduce tire life, and excessive temperature can lead to sudden tire failure. The grade C corresponds to a level of performance which all passenger car tires must meet under the Federal Motor Safety Standard No.

Technical and consumer information 9-23

109. Grades B and A represent higher levels of performance on the laboratory test wheel than the minimum required by law.



WARNING

The temperature grade for this tire is established for a tire that is properly inflated and not overloaded. Excessive speed, under-inflation, or excessive loading, either separately or in combination, can cause heat build-up and possible tire failure.

EMISSION CONTROL SYSTEM WARRANTY

Your INFINITI is covered by the following emission warranties.

For US:

- Emission Defects Warranty
- Emissions Performance Warranty (See Warranty Information Booklet for details.)

For Canada:

Emission Control System Warranty

Details of these warranties may be found with other vehicle warranties in your Warranty Information Booklet (Warranty and Roadside Assistance Information (Canada only)) that comes with your INFINITI. If you did not receive a Warranty Information Booklet (Warranty and Roadside Assistance Information (Canada only)), or it has become lost, you may obtain a replacement by writing to:

- INFINITI Division
Nissan North America, Inc.
Consumer Affairs Department
P.O. Box 47038, Gardena, CA 90247-6838
- Nissan Canada Inc.
5290 Orbitor Drive
Mississauga, Ontario, L4W 4Z5

REPORTING SAFETY DEFECTS (US only)

If you believe that your vehicle has a defect which could cause a crash or could cause injury or death, you should immediately inform the National Highway Traffic Safety Administration (NHTSA) in addition to notifying INFINITI.

If NHTSA receives similar complaints, it may open an investigation, and if it finds that a safety defect exists in a group of vehicles, it may order a recall and remedy campaign. However, NHTSA cannot become involved in individual problems between you, your dealer, or INFINITI.

To contact NHTSA, you may call the Vehicle Safety Hotline toll-free at 1-888-327-4236 (TTY: 1-800-424-9153); go to <http://www.safercar.gov>; or write to: Administrator, NHTSA, 400 Seventh Street, SW., Washington, DC 20590. You can also obtain other information about motor vehicle safety from <http://www.safercar.gov>.

You may notify INFINITI by contacting our Consumer Affairs Department, toll-free, at 1-800-662-6200.

READINESS FOR INSPECTION/ MAINTENANCE (I/M) TEST (US only)

A vehicle equipped with All-Wheel Drive (AWD) should never be tested using a two wheel dynamometer (such as the dynamometers used by some states for emissions testing), or similar equipment. Make sure you inform test facility personnel that your vehicle is equipped with AWD before it is placed on a dynamometer. Using the wrong test equipment may result in transmission damage or unexpected vehicle movement which could result in serious vehicle damage or personal injury.

Due to legal requirements in some states/areas, your vehicle may be required to be in what is called the “ready condition” for an Inspection/Maintenance (I/M) test of the emission control system.

The vehicle is set to the “ready condition” when it is driven through certain driving patterns. Usually, the “ready condition” can be obtained by ordinary usage of the vehicle.

If a powertrain system component is repaired or the battery is disconnected, the vehicle may be reset to a not “ready condition”. Before taking the I/M test, check the vehicle’s inspection/maintenance test readiness condition. Turn the ignition

switch ON without starting the engine. If the Malfunction Indicator Lamp (MIL) comes on steady for 20 seconds and then blinks for 10 seconds, the I/M test condition is “not ready”. If the MIL does not blink after 20 seconds, the I/M test condition is “ready”. If the MIL indicates the vehicle is in a “not ready” condition, drive the vehicle through the following pattern to set the vehicle to the ready condition. If you cannot or do not want to perform the driving pattern, an INFINITI dealer can conduct it for you.



WARNING

Always drive the vehicle in a safe and prudent manner according to traffic conditions and obey all traffic laws.

1. Start the engine. Allow the engine to idle until the engine coolant temperature gauge needle points between the C and H (normal operating temperature).
2. Accelerate the vehicle to 55 MPH (88 km/h), then quickly release the accelerator pedal completely and keep it released for at least 10 seconds.

3. Quickly depress the accelerator pedal for a moment, then drive the vehicle at a speed of 53 to 60 MPH (86 to 96 km/h) for at least 9 minutes.
4. Stop the vehicle. Leave the engine running.
5. Accelerate the vehicle to 35 MPH (55 km/h) and maintain the speed for 20 seconds.
6. Repeat steps 4 and 5 at least 10 times.
7. Accelerate the vehicle to 55 MPH (88 km/h) and maintain the speed for at least 3 minutes.
8. Stop the vehicle. Place the automatic transmission selector lever in the “P” or “N” position or the manual transmission shift lever in the “N” position.
9. Turn the engine off.
10. Repeat steps 1 through 8 at least one more time.

If step 1 through 7 is interrupted, repeat the preceding step. Any safe driving mode is acceptable between steps. Do not stop the engine until step 7 is completed.

EVENT DATA RECORDERS

Your vehicle is equipped with a variety of computers that monitor and control a number of systems to optimize performance and help service technicians with diagnosis and repair. Some of the computers monitor emission control systems, braking systems, engine systems, transmission systems, tire pressure systems, and air bag systems. Some data about vehicle operation may be stored in the computers for use during servicing. Other data may be stored if a crash event occurs. For example, vehicle speed, brake application, steering angle, air bag readiness, air bag performance, and seat belt use by the driver or passenger may be recorded. These types of systems are sometimes called Event Data Recorders.

Special equipment can be used to access the electronic data that may be stored in the vehicle's computers (sounds are not recorded). INFINITI and INFINITI dealers have equipment to access some of this data; others may also have this equipment. The data may be retrieved during routine vehicle servicing or for special research. It might also be accessed with the consent of the vehicle owner or lessee, in response to a request by law enforcement, or as otherwise required or permitted by law.

OWNER'S MANUAL/SERVICE MANUAL ORDER INFORMATION

A genuine INFINITI Service Manual is the best source of service and repair information for your vehicle. Filled with wiring diagrams, illustrations and step-by-step diagnostic and adjustment procedures, this manual is the same one used by the factory trained technicians working at an INFINITI dealer. Also available are genuine INFINITI Owner's Manuals, and genuine INFINITI Service and Owner's Manuals for older INFINITI models.

In the USA:

For current pricing and availability of genuine **INFINITI Service Manuals** for the 2000 model year and later, contact:

Tweddle Litho Company
1-800-450-9491
www.nissan-techinfo.com

For current pricing and availability of genuine **INFINITI Service Manuals** for the 1999 model year and prior, see an INFINITI dealer, or contact:

Resolve Corporation
20770 Westwood Road
Strongsville, OH 44136
1-800-247-5321

For current pricing and availability of genuine **INFINITI Owner's Manuals** for this

model year and prior, see an INFINITI dealer, or contact:

Resolve Corporation
20770 Westwood Road
Strongsville, OH 44136
1-800-247-5321

In Canada:

To purchase a copy of a genuine INFINITI Service Manual or Owner's Manual please contact an INFINITI dealer. For the phone number and location of an INFINITI dealer in your area call the INFINITI Satisfaction Center at 1-800-361-4792 and a bilingual INFINITI representative will assist you.

Also available are genuine INFINITI Service and Owner's Manuals for older INFINITI models.

IN THE EVENT OF A COLLISION

Unfortunately, accidents do occur. In this unlikely event, there is some important information you should know. Many insurance companies routinely authorize the use of non-genuine collision parts in order to cut costs, among other reasons.

Insist on the use of Genuine INFINITI Collision Parts!

If you want your vehicle to be restored using parts made to INFINITI's original exacting specifications — if you want to help it to last and hold its resale value, the solution is simple. **Tell your insurance agent and your repair shop to only use Genuine INFINITI Collision Parts.** INFINITI does not warrant non-INFINITI parts, nor does INFINITI's warranty apply to damage caused by a non-genuine parts.

Using Genuine INFINITI Parts can help protect your personal safety, preserve your warranty protection and maintain the resale value of your vehicle. And if your vehicle was leased, using Genuine INFINITI Parts may prevent or limit unnecessary excess wear and tear expenses at the end of your lease.

INFINITI designs its hoods with crumple zones to minimize the risk that the hood will penetrate the windshield of your vehicle in an accident. Non-genuine (imitation) parts may not provide such built-in safety features. Also, non-genuine parts often show premature wear, rust and corrosion.

Why should you take a chance?

In over 40 states, the law says you must be advised if non-genuine parts are used to repair your vehicle. And some states/provinces have enacted laws that restrict insurance companies from authorizing the use of non-genuine collision parts during the new vehicle warranty. These laws help protect you, so you can take action to protect yourself.

It's your right!

If you should need further information visit us at:

www.infiniti.com (for U.S. customers) or
www.infiniti.ca (for Canadian customers)

MEMO

10 Index

A

ABS (Anti-lock brake system)	5-26
Advanced air bag system	1-42
Air bag system	
Front (See INFINITI advanced air bag system)	1-42
Side and curtain (See supplemental side air bag and curtain side-impact air bag systems)	1-48
Front passenger air bag and status light ...	1-44
Air bag warning labels	1-51
Air bag warning light	1-51, 2-14
Air cleaner housing filter	8-20
Air conditioner	
Air conditioner operation	4-10
Air conditioner service	4-10, 4-14
Air conditioner specification label	9-13
Air conditioning system refrigerant and lubricant recommendations	4-14, 9-7
Ambient temperature	4-13
Heater and air conditioner (automatic)	4-10
In-cabin microfilter	4-13
Alcohol, drugs and driving	5-5
All-wheel drive (AWD)	5-23
All-wheel drive (AWD) warning light	2-9
Anchor point locations	
Top tether strap	1-27
Antenna	4-29

B

Anti-lock Brake System (ABS)	5-26
Anti-lock brake warning light	2-10
Appearance care	
Exterior appearance care	7-2
Interior appearance care	7-4
Armrest	
Rear armrest pocket	2-37
Ashtray (See cigarette lighter and ashtray)	2-30
Audible reminders	2-16
Audio operation precautions	4-16
Audio system	4-14
Steering wheel switch for audio control	4-28
Autochanger	
Compact Disc (CD)	4-25
Autolight system	2-22
Automatic	
Anti-glare inside mirror	3-32
Automatic adjusting function	2-41
Automatic sunroof	2-42
Automatic transmission fluid (ATF)	8-13
Drive positioner	3-34
Driving with automatic transmission ...	5-6, 5-12
Avoiding collision and rollover	5-5

C

Belts (See drive belts)	8-19
Bluetooth [®] Hands-Free Phone System	4-30
Booster seats	1-31
Brake	
Anti-lock brake system (ABS)	5-26
Brake and clutch fluid	8-14
Brake booster	8-24
Brake fluid	8-14
Brake pedal	8-23
Brake pedal check	8-23
Brake system	5-26
Parking brake check	5-19, 8-23
Parking brake operation	5-19
Warning light	2-10
Break-in schedule	5-22
Brightness control, Instrument panel	2-24
Bulb check/instrument panel	2-9
Bulb replacement	8-31

Capacities and recommended fuel/lubricants ...	9-2
Car phone or CB radio	4-29
Card holder	2-38
CD care and cleaning	4-27
Child restraints	1-18
Booster seats	1-31
Installation on front passenger seat	1-28

Installation on rear seat outboard or center positions	1-20
Precautions on child restraints	1-18
Top tether strap anchor point locations	1-27
Child safety	1-12
Child safety rear door lock.....	3-5
Chimes	
Audible reminders	2-16
Seat belt warning light and chime.....	2-13
Cigarette lighter and ashtray	2-30
Circuit breaker, Fusible link	8-26
Cleaning exterior and interior	7-2, 7-4
Clock	2-29
Clutch fluid	8-14
Coat hook.....	2-38
Cold weather driving.....	5-30
Command (See Bluetooth® Hands-Free Phone System)	4-36
Compact Disc (CD) changer operation	4-25
Compass display	2-6
Console box	2-36
Control panel buttons (models with navigation system)	4-2
Controls	
Control panel buttons (display with navigation system).....	4-2
Heater and air conditioner controls (automatic).....	4-10
Steering wheel audio controls	4-28
Coolant	
Capacities and recommended fuel/lubricants	9-2
Changing engine coolant	8-9
Checking engine coolant level	8-8

Corrosion protection	7-5
Cruise control	5-20
Cup holder.....	2-32
Curtain side-impact air bag system (See supplemental side air bag and curtain side-impact air bag systems)	1-48

D

Daytime running light system	2-24
Defroster switch, Rear window and outside mirror defroster switch	2-20
Dimensions and weights	9-9
Display controls (See control panel buttons), With navigation system	4-2
Door open warning light	2-11
Door Pockets.....	2-31
Drive belts	8-19
Drive positioner, Automatic.....	3-34
Driving	
All-wheel drive (AWD) safety precautions	5-6
Cold weather driving.....	5-30
Driving with automatic transmission... ..	5-6, 5-12
Driving with manual transmission	5-7, 5-16
Precautions when starting and driving	5-2

E

Economy, Fuel.....	5-22
Emission control information label	9-12
Emission control system warranty	9-24
Engine	
Before starting the engine	5-10
Break-in schedule	5-22

Capacities and recommended fuel/lubricants	9-2
Changing engine coolant	8-9
Changing engine oil and filter.....	8-11
Checking engine coolant level	8-8
Checking engine oil level	8-10
Coolant temperature gauge.....	2-4
Engine block heater	5-32
Engine compartment check locations	8-7
Engine cooling system.....	8-8
Engine oil.....	8-10
Engine oil and oil filter recommendation.....	9-5
Engine oil viscosity	9-5
Engine serial number.....	9-11
Engine specifications	9-8
If your vehicle overheats.....	6-11
Starting the engine	5-11

Entry/exit function, Automatic drive positioner	3-34
Event data recorders.....	9-26
Exhaust gas (Carbon monoxide).....	5-2

F

F.M.V.S.S./C.M.V.S.S. certification label	9-11
Filter	
Air cleaner housing filter	8-20
Changing engine oil and filter.....	8-11
Flashers (See hazard warning flasher switch).....	2-25
Flat tire.....	6-2
Flat tire, Tire pressure monitoring system (TPMS).....	5-3
Flat towing.....	9-22

Floor mat cleaning.....	7-4
Fluid	
Automatic transmission fluid (ATF).....	8-13
Brake and clutch fluid.....	8-14
Brake fluid.....	8-14
Capacities and recommended fuel/ lubricants.....	9-2
Engine coolant.....	8-8
Engine oil.....	8-10
Power steering fluid.....	8-13
Window washer fluid.....	8-15
FM-AM-SATELLITE radio with compact disc (CD) changer.....	4-22
Fog light switch.....	2-25
Front passenger air bag and status light.....	1-44
Front power seat adjustment.....	1-2
Fuel	
Capacities and recommended fuel/ lubricants.....	9-2
Fuel economy.....	5-22
Fuel economy information (display).....	4-4
Fuel-filler cap.....	3-28
Fuel-filler door.....	3-28
Fuel octane rating.....	9-3
Fuel recommendation.....	9-3
Gauge.....	2-5
Fuses.....	8-25
Fusible links.....	8-26

G

Garage door opener, HomeLink [®] Universal Transceiver.....	2-46
Gas cap.....	3-28

Gauge.....	2-3
Engine coolant temperature gauge.....	2-4
Fuel gauge.....	2-5
Odometer.....	2-3
Speedometer.....	2-3
Tachometer.....	2-4
General maintenance.....	8-2
Glove box.....	2-35
Glove box (upper).....	2-35
Glove box lock.....	2-35
Golf bag stowing.....	2-39

H

Hands-Free Phone System, Bluetooth [®]	4-30
Hazard warning flasher switch.....	2-25
Head restraints.....	1-8
Headlights	
Bulb replacement.....	8-33
Headlight switch.....	2-21
Xenon headlights.....	2-21
Heated seats.....	2-26
Heater	
Engine block heater.....	5-32
Heater and air conditioner (automatic).....	4-10
HomeLink [®] Universal Transceiver.....	2-46
Hood release.....	3-24
Hook, Coat hook.....	2-38
Horn.....	2-26
How to stop alarm, Vehicle security.....	2-18

I

Ignition switch (except Intelligent Key system).....	5-6
Automatic transmission models.....	5-6, 5-12
Key positions.....	5-8
Manual transmission models.....	5-7, 5-16
Immobilizer system.....	2-18
In-cabin microfilter.....	4-13
Indicator lights.....	2-14
INFINITI Vehicle Immobilizer System	
Engine start.....	5-8, 5-10
Inside	
Automatic anti-glare mirror.....	3-32
Inspection/maintenance (I/M) test.....	9-25
Instrument brightness control.....	2-24
Instrument panel.....	2-2
Instrument pocket.....	2-31
Intelligent Key system	
Engine starting.....	3-14
Key operating range.....	3-16
Key operation.....	3-11
Mechanical key and valet key.....	3-23
Operating the engine.....	3-14
Remote keyless operation.....	3-20
Trouble-shooting guide.....	3-19
Warning light.....	2-12
Warning signals.....	3-17
Intelligent Key warning light.....	2-12
Interior light replacement.....	8-33
Interior lights.....	2-44
Interior trunk lid release.....	3-27
ISOFIX child restraint.....	1-25

J

Jump starting 6-8

K

Keyless entry

With Intelligent Key system (See Intelligent Key system)..... 3-20
Without Intelligent Key system (See remote keyless entry system)..... 3-5

Keys 3-2

L

Labels

Air bag warning labels 1-51
Air conditioner specification label 9-13
Emission control information label 9-12
Engine serial number 9-11
F.M.V.S.S./C.M.V.S.S. certification label..... 9-11
Tire and Loading Information label 9-12
Vehicle identification number (VIN) 9-10

LATCH (Lower Anchors and Tethers for Children) system 1-25

License plate, Installing front license plate 9-13

Light

Air bag warning light..... 1-51
Bulb replacement 8-31
Fog light switch..... 2-25
Headlight switch..... 2-21
Headlights Bulb replacement 8-33
Interior lights..... 2-44

Map lights 2-44
Personal lights 2-45
Replacement..... 8-31
Room light 2-44
Trunk light 2-46
Vanity mirror light..... 2-46
Warning/indicator lights and audible reminders..... 2-9, 2-14
Xenon headlights 2-21

Lights, Exterior and interior light replacement..... 8-33

Loading information (See vehicle loading information) 9-14

Lock

Door locks 3-3
Glove box lock 2-35
Power door lock..... 3-3
Trunk lid 3-25

Low fuel warning light..... 2-12

Low tire pressure warning light 2-12

M

Maintenance

Battery 8-16
General maintenance 8-2
Inside the vehicle 8-4
Maintenance information (display) 4-5
Maintenance precautions 8-5
Maintenance requirements..... 8-2
Outside the vehicle..... 8-3
Seat belt maintenance 1-17
Under the hood and vehicle 8-4
Malfunction indicator lamp (MIL) 2-15

Map lights 2-44
Mechanical key (for Intelligent Key system) 3-23
Memory storage, Automatic drive positioner 3-35
Meters and gauges 2-3
Meters and gauges, Instrument brightness control 2-24
Mirror

Automatic anti-glare inside mirror 3-32
Outside mirror control 3-33
Outside mirrors 3-33

N

New vehicle break-in..... 5-22

O

Odometer 2-3

Oil

Capacities and recommended fuel/lubricants 9-2
Changing engine oil and filter..... 8-11
Checking engine oil level 8-10
Engine oil..... 8-10
Engine oil viscosity 9-5

Operating the engine (Intelligent Key system) 3-14

Outside mirror control 3-33

Outside mirrors..... 3-33

Overheat, If your vehicle overheats..... 6-11

Owner's Manual/Service Manual order information..... 9-26

P

Parking	
Brake check.....	8-23
Parking brake check.....	5-19
Parking brake operation	5-19
Parking on hills	5-19
Parking/parking on hills	5-24
Personal lights.....	2-45
Phone	
Bluetooth® Hands-Free Phone System	4-30
Car phone or CB radio	4-29
Power	
Front seat adjustment	1-2
Power door lock.....	3-3
Power outlet	2-29
Power steering fluid	8-13
Power steering system	5-25
Power windows.....	2-39
Precautions	
All-wheel drive (AWD) driving safety.....	5-6
Audio operation.....	4-16
Braking precautions	5-26
Child restraints	1-18
Cruise control	5-20
Maintenance	8-5
Seat belt usage.....	1-9
Supplemental restraint system	1-36
When starting and driving.....	5-2
Push starting	6-10

R

Radio	
Car phone or CB radio	4-29
Steering wheel switch for audio control....	4-28
Readiness for inspection/maintenance (I/M) test (US only).....	9-25
Rear active steer (RAS) system.....	5-29
Rear armrest pocket.....	2-37
Rear door lock, Child safety rear door lock.....	3-5
Rear power point	2-29
Rear seat adjustment	1-5
Rear window and outside mirror defroster switch.....	2-20
Recorders, Event data.....	9-26
Registering your vehicle in another country	9-10
Remote keyless entry system	
Except Intelligent Key system.....	3-5
For Intelligent Key system.....	3-20
Reporting safety defects (US only).....	9-24
Roadside assistance program.....	6-2
Rollover	5-5
Room light.....	2-44

S

Safety	
Child seat belts.....	1-12
Reporting safety defects (US only)	9-24
Towing safety	9-19
Seat	
Belt warning light.....	1-9
Belt warning light and chime.....	2-13

Seat adjustment	
Front power seat adjustment.....	1-2
Rear seat adjustment.....	1-5
Seat belt(s)	
Child safety.....	1-12
Infants	1-12
Injured persons.....	1-13
Larger children.....	1-13
Precautions on seat belt usage	1-9
Pregnant women	1-13
Pre-tensioner seat belt system	1-50
Seat belt cleaning.....	7-5
Seat belt extenders.....	1-17
Seat belt maintenance	1-17
Seat belts.....	1-9
Seat belt warning light	2-13
Shoulder belt guide	1-17
Shoulder belt height adjustment.....	1-16
Small children.....	1-12
Three-point type with retractor.....	1-13
Seat(s)	
Driver-side memory	3-34
Heated seats.....	2-26
Seats.....	1-2
Secondary trunk lid release	3-27
Security system, Vehicle security system	2-17
Security systems (INFINITI Vehicle Immobilizer System), Engine start	2-18
Security systems (See vehicle security system)	2-17
Selector lever, Shift lock release	5-15
Servicing air conditioner.....	4-10, 4-14
Shift lock release, Transmission	5-15

Shifting	
Automatic transmission	5-6, 5-12
Manual transmission	5-7, 5-16
Shoulder belt guide	1-17
Shoulder belt height adjustment	1-16
Side air bag system (See supplemental side air bag and curtain side-impact air bag systems)	1-48
SNOW mode switch	2-27
Spark plugs	8-19
Speedometer	2-3
Starting	
Before starting the engine	5-10
Jump starting	6-8
Precautions when starting and driving	5-2
Push starting	6-10
Starting the engine	5-11
Status light, Front passenger air bag	1-44
Steering	
Power steering fluid	8-13
Power steering system	5-25
Rear active steer (RAS) system	5-29
Steering wheel switch for audio controls	4-28
Tilting steering wheel	3-30
Storage	2-31
Stowing golf bags	2-39
Sun shade	2-42
Sun visors	3-32
Sunglasses holder	2-32
Sunroof	2-42
Automatic sunroof	2-42
Supplemental air bag warning labels	1-51
Supplemental air bag warning light	1-51, 2-14

Supplemental restraint system	1-36
Precautions on supplemental restraint system	1-36
Supplemental side and curtain side-impact air bag systems	1-48
Switch	
Autolight switch	2-22
Fog light switch	2-25
Hazard warning flasher switch	2-25
Headlight switch	2-21
Ignition switch (except Intelligent Key system)	5-6
Ignition switch automatic transmission models	5-6, 5-12
Ignition switch manual transmission models	5-7, 5-16
Power door lock switch	3-4
Rear window and outside mirror defroster switch	2-20
Steering wheel switch for audio control	4-28
Turn signal switch	2-24
Vehicle Dynamic Control (VDC) off switch	2-28

T

Tachometer	2-4
Temperature gauge, Engine coolant temperature gauge	2-4
Theft (INFINITI Vehicle Immobilizer System), Engine start	2-18
Three way catalyst	5-3
Tilting steering wheel	3-30

Tire	
Flat tire	6-2
Pressure, Low tire pressure warning light	2-12
Tire pressure monitoring system (TPMS)	5-3
Uniform tire quality grading	9-23
Tires	
Spare tire	8-48
Tire and Loading Information label	9-12
Tire chains	8-44
Tire dressing	7-3
Tire pressure	8-37
Tire pressure monitoring system (TPMS)	5-3, 6-2
Tire rotation	8-45
Types of tires	8-43
Wheel/tire size	9-9
Wheels and tires	8-37
Top tether strap child restraints	1-26
Towing	
Flat towing	9-22
Tow truck towing	6-12
Towing a trailer	9-18
Towing load/specification chart	9-18
Towing safety	9-19
TPMS, Tire pressure monitoring system	5-3
Trailer towing	9-18
Transceiver, HomeLink® Universal Transceiver	2-46
Transmission	
Automatic transmission fluid (ATF)	8-13
Driving with automatic transmission	5-6, 5-12
Driving with manual transmission	5-7, 5-16
Transmission selector lever lock release	5-15

Transmitter	
With Intelligent Key system (See Intelligent Key system).....	3-20
Without Intelligent Key system (See remote keyless entry system).....	3-5
Traveling or registering your vehicle in another country	9-10
Trip computer information (display)	4-5
Troubleshooting guide	
Audio system	4-20
Bluetooth [®] Hands-Free Phone System	4-41
Intelligent Key system	3-19
Trunk	
Interior trunk lid release	3-27
Light	2-46
Secondary trunk lid release	3-27
Trunk lid	3-25
Turn signal switch	2-24

U

Underbody cleaning	7-3
Uniform tire quality grading	9-23
Up-shift indicator (MT models).....	5-17
Up-shift indicator setting (MT models)	2-3

V

Valet key (for Intelligent Key system).....	3-23
Vanity mirror light	2-46
Vehicle	
Dimensions and weights.....	9-9
Identification number (VIN).....	9-10
Loading information	9-14

Recovery (freeing a stuck vehicle).....	6-15
Security system	2-17
Vehicle Dynamic Control (VDC) off switch.....	2-28
Vehicle Dynamic Control (VDC) system	5-28
Ventilators.....	4-9
Voice command (See Bluetooth [®] Hands-Free Phone System)	4-36

W

Walk-in mechanism	1-4
Warning labels, Air bag warning labels	1-51
Warning light	
Air bag warning light	1-51, 2-14
All-wheel drive (AWD) warning light	2-9
Anti-lock brake warning light.....	2-10
Brake warning light	2-10
Door open warning light	2-11
Intelligent Key warning light.....	2-12
Low fuel warning light	2-12
Low tire pressure warning light	2-12
Seat belt warning light and chime.....	2-13
Warning lights	2-9
Warning, Hazard warning flasher switch	2-25
Warning, Tire pressure monitoring system (TPMS).....	5-3, 6-2
Warning, Warning/indicator lights and audible reminders	2-9
Warranty, Emission control system warranty....	9-24
Washer switch, Windshield wiper and washer switch	2-19
Washing	7-2
Waxing	7-2

Weights (See dimensions and weights)	9-9
Wheel/tire size	9-9
Wheels and tires.....	8-37
Cleaning aluminum alloy wheels.....	7-3
Wheels, Rear active steer (RAS) system	5-29
Window washer fluid.....	8-15
Window(s)	
Automatic adjusting function	2-41
Cleaning	7-3
Power windows	2-39
Windshield wiper and washer switch	2-19
Wiper	
Windshield wiper and washer switch.....	2-19
Wiper blades	8-21

X

Xenon headlights	2-21
------------------------	------

MEMO

10-8

GAS STATION INFORMATION

FUEL RECOMMENDATION:

Sedan models

Use unleaded regular gasoline with an octane rating of at least 87 AKI (Anti-Knock Index) number (Research octane number 91).

For improved vehicle performance, INFINITI recommends the use of unleaded premium gasoline with an octane rating of at least 91 AKI number (Research octane number 96).

Coupe models

Use unleaded premium gasoline with an octane rating of at least 91 AKI (Anti-Knock Index) number (Research octane number 96).

If premium gasoline is not available, unleaded regular gasoline with an octane rating of 87 AKI number (Research octane number 91) may be temporarily used, but only under the following precautions:

- Have the fuel tank filled only partially with unleaded regular gasoline, and fill up with unleaded premium gasoline as soon as possible.
- Avoid full throttle driving and abrupt acceleration.

However, for maximum vehicle performance, the use of unleaded premium gasoline is recommended.



CAUTION

- **Using a fuel other than that specified could adversely affect the emission control system, and may also affect the warranty coverage.**
- **Under no circumstances should a leaded gasoline be used, because this will damage the three-way catalyst.**
- **Do not use E-85 fuel in your vehicle. Your vehicle is not designed to run on E-85 fuel. Using E-85 fuel can damage the fuel system components and is not covered by the INFINITI vehicle limited warranty.**

For additional information, see “Capacities and recommended fuel/lubricants” in the “9. Technical and consumer information” section.

ENGINE OIL RECOMMENDATION:

- API Certification Mark

- API grade SG/SH, Energy Conserving I & II or API grade SJ or SL, Energy Conserving
- ILSAC grade GF-I, GF-II & GF-III
- SAE 5W-30 viscosity oil is preferred for all ambient temperatures. SAE 10W-30 viscosity oil may be used for ambient temperatures above 0°F (-18°C).

See “Capacities and recommended fuel/lubricants” in the “9. Technical and consumer information” section for engine oil and oil filter recommendation.

COLD TIRE PRESSURES:

See Tire and Loading Information label affixed to the inside of the driver side center pillar.

NEW VEHICLE BREAK-IN PROCEDURES RECOMMENDATION:

During the first 1,200 miles (2,000 km) of vehicle use, follow the recommendations outlined in the “Break-in schedule” Information found in the “5. Starting and driving” section of this Owner’s Manual. Follow these recommendations for the future reliability and economy of your new vehicle.

QUICK REFERENCE

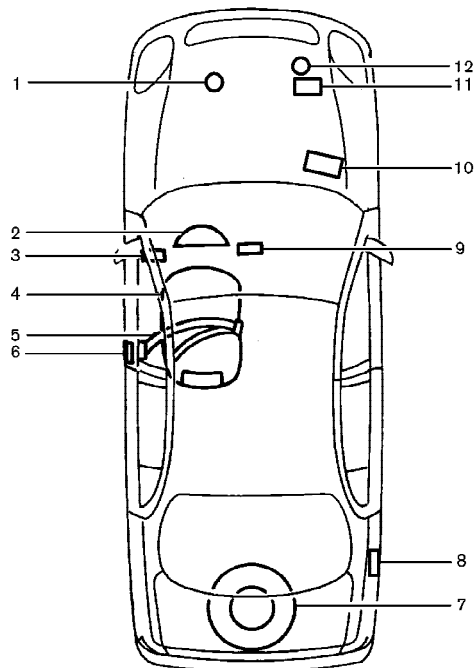

1. Engine oil 8-10
2. Meters and gauges 2-3
3. Hood release 3-24
4. Seat 1-2
5. Seat belt 1-9
6. Key 3-2
7. Spare tire 6-4, 8-48
8. Fuel 3-28, 9-2
9. Audio system 4-14
Heater and air conditioner 4-10
10. Battery 8-16
11. Engine coolant 8-8
12. Windshield washer fluid 8-15