

2018

SIERRA HD



UNRELENTING LIKE A PRO

There are trucks, and then there are the 2018 Sierra 2500HD and 3500HD. They go all in on premium with quiet, refined interiors that put you in command of an available 6.6L Duramax Turbo Diesel engine—our most powerful ever—for robust hauling and trailering. They're the latest reminders that the same passion and purpose that drive you also drive us. We set our own standards and prove that Professional Grade isn't merely a label, it's a way of life. Sierra HD is a shining example of how we take a strong stance for what we believe in and pursue it like a pro.





SIERRA 2500HD SLT CREW CAB IN RED QUARTZ TINTCOAT (left)
SIERRA 3500 DENALI HD CREW CAB WITH DUAL REAR WHEELS IN DARK SLATE METALLIC (centre)
SIERRA 2500 DENALI HD CREW CAB IN ONYX BLACK (right)
Vehicles shown with available equipment.



ENGINEERING

WHEN YOU'RE KNOWN FOR AMAZING FEATS OF ENGINEERING, YOU'RE CONSTANTLY LOOKING FOR A NEW GEAR TO SHIFT INTO. FORTUNATELY, WE FOUND IT WITHIN OURSELVES. YOU'LL FIND THE RESULT IN SIERRA HD.

WORKS HARD. HARDLY BREAKS A SWEAT.

Sierra HD trucks are designed, engineered and built to help you achieve more with the heavy-duty capability of the available 6.6L Duramax Turbo Diesel paired with the Allison® 1000 transmission. Sierra 3500 Denali HD offers robust payload and trailering as well as premium comfort and technology. Sierra 2500 Denali HD packs the same craftsmanship and un-truck-like accommodations. And for those who venture off pavement, the HD All Terrain tackles roads less paved. They all feature quiet cabins and innovative cargo boxes.



SIERRA 3500 DENALI HD CREW CAB WITH DUAL REAR WHEELS IN ONYX BLACK
shown with available equipment.



SIERRA 3500HD CREW CAB SLT IN RED QUARTZ TINTCOAT
shown with available equipment.

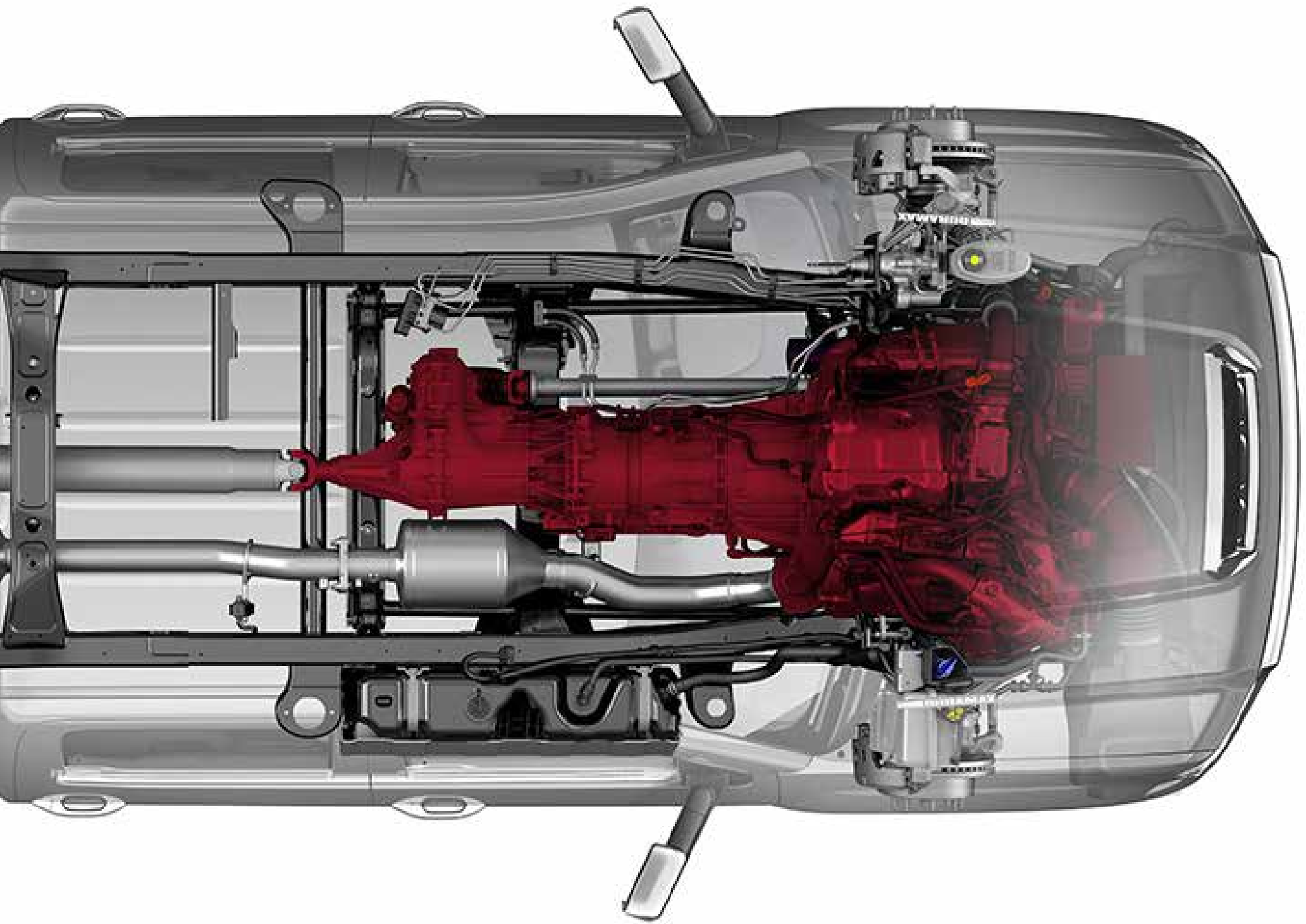

445
HORSEPOWER
910
lb.-ft. of
TORQUE
DURAMAX

OUR MOST POWERFUL DURAMAX DIESEL-EVER

Sierra HD gets its heavy-duty power from a proven source, the available Duramax 6.6L V8 Turbo Diesel with 910 lb.-ft. of torque and 445 hp under your right foot. Prefer your power gasoline-fuelled? Sierra HD comes standard with the force and efficiency of our 330-hp Vortec 6.0L V8.

- + Hood-Scoop Induction System Provides Cooler Induction Air Temperatures to Maximize Horsepower (Duramax)
- + Large Radiator Capacity for Excellent Cooling Performance (Duramax)
- + Allison 1000 6-Speed Automatic Transmission (Duramax)



THE TURNING POINT

GMC engineers love challenges. Sierra HD offers a steering system smart enough to tailor its response to your unique driving situation, in real time. Available Digital Steering Assist senses speed (especially important when trailering) to enable ease of handling at low speeds and improved steering feel at highway speeds. It also changes when the Tow/Haul button is activated, providing additional assist at reduced speeds and less at highway cruising speeds.

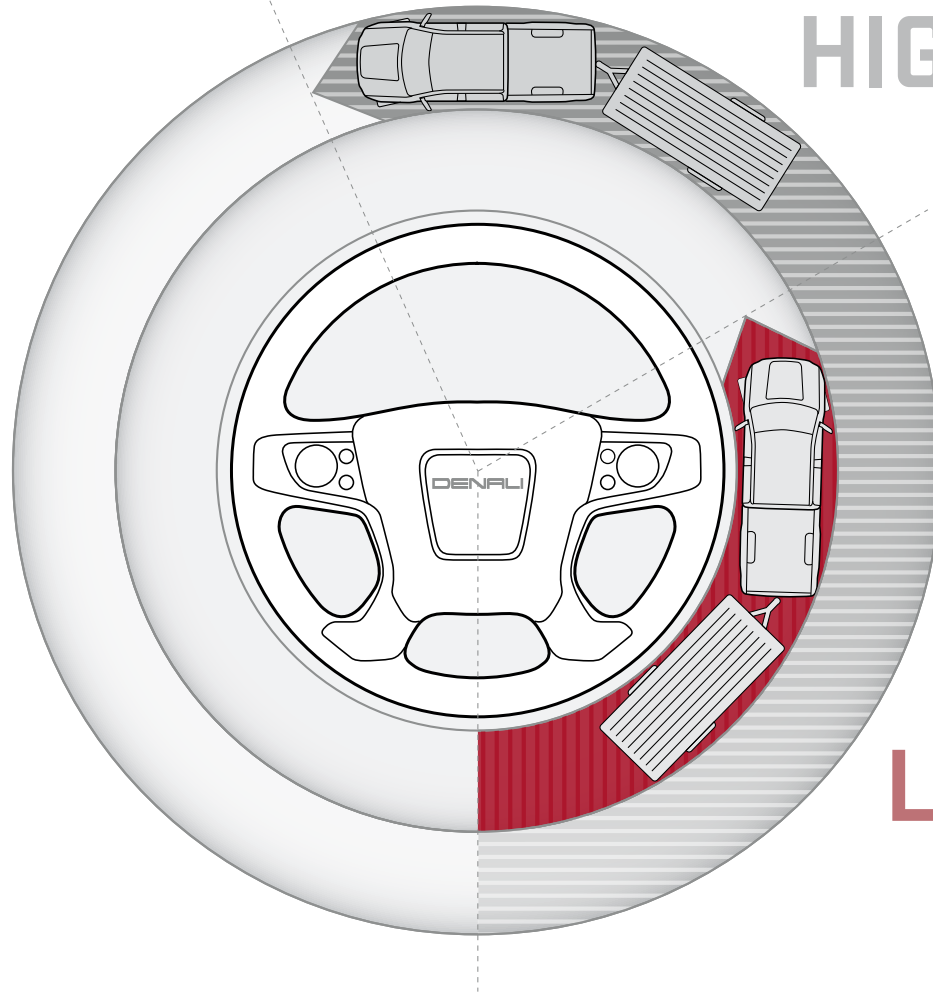

HIGHWAY SPEED

HIGHWAY DRIVING While cruising at highway speeds, Digital Steering Assist decreases power assist to enhance road feel for heightened confidence and reduced driver fatigue on uneven roads.

LOW SPEED

TRAILERING & PARKING In low-speed situations, such as hitching up to a trailer or parking, Digital Steering Assist increases power steering assist for easier low-speed manoeuvrability.

A STRUCTURE OF STRENGTH

VORTEC 6.0L V8 It's standard on Sierra HD for uncompromised power. Developed for heavy-duty performance, it's paired with a 6-speed heavy-duty automatic transmission for maximum fifth-wheel towing of up to 6713 kg (14,800 lb.).¹

FULLY BOXED FRAME The Sierra HD frame is fully boxed, with the front segments hydroformed to minimize weight without sacrificing strength to tackle the toughest heavy-duty demands.

EATON® HEAVY-DUTY AUTOMATIC LOCKING REAR DIFFERENTIAL No other class² competitor offers a fully automatic locking rear differential for on- and off-road use.

CORROSION-RESISTANT DURALIFE BRAKE ROTORS GMC engineers used patented Ferritic Nitro-Carburizing (FNC) technology that can help double rotor life.

MULTILEAF REAR SPRINGS Mounted to the rear frame are 3"-wide leaf springs that help achieve a maximum payload rating of up to 3245 kg (7153 lb.).³

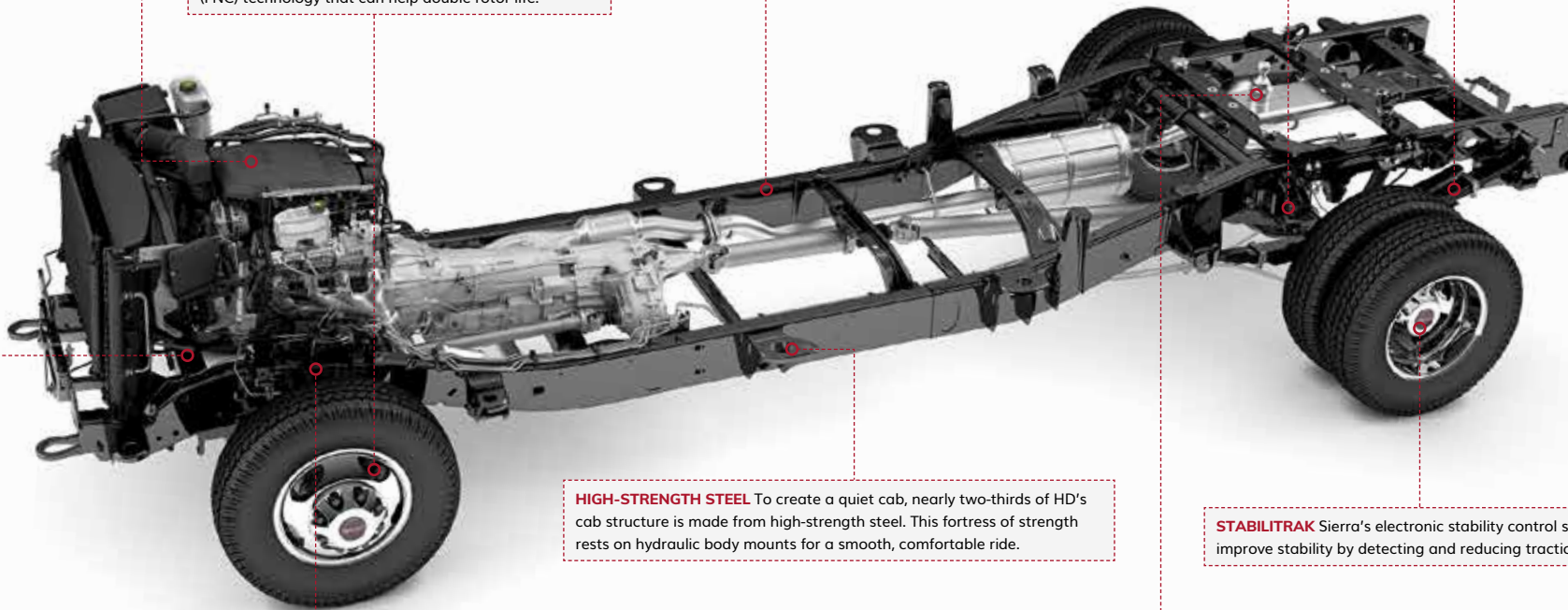

HIGH-STRENGTH STEEL To create a quiet cab, nearly two-thirds of HD's cab structure is made from high-strength steel. This fortress of strength rests on hydraulic body mounts for a smooth, comfortable ride.

STABILITRAK Sierra's electronic stability control system helps improve stability by detecting and reducing traction loss.

INDEPENDENT FRONT SUSPENSION Sierra HD's independent front suspension is designed for heavy-duty punishment as well as ride comfort. With the available Snow Plow Prep Package, Sierra HD achieves a Front Gross Axle Weight Rating of up to 2722 kg (6000 lb.).⁴ You can make seasonal ride-height adjustments in minutes with a single wrench.

HEAVY-DUTY-CAPABLE HITCHES For heavy loads, the available conventional hitch mounted to the rear of Sierra HD offers optimal weight-carrying and weight-distributing properties of up to 9072 kg (20,000 lb.)¹ when properly equipped. And for trailering the heaviest of loads of up to 10,569 kg (23,300 lb.)¹ when properly equipped, the available Gooseneck/Fifth-Wheel Prep Package makes Sierra HD models ready right from the factory to tow larger trailers. It features a frame-mounted hitch platform welded in place underneath the pickup box that accommodates a gooseneck ball hitch or fifth-wheel hitch-mounting brackets and includes a cargo-bed-mounted trailer harness.

¹Before you buy a vehicle or use it for trailering, carefully review the trailering section of the Owner's Manual. The weight of passengers, cargo and options or accessories may reduce the amount you can tow. ²Comparison based on wardsauto.com 2017 Large Pickup segment and latest competitive information available at the time of printing. Excludes other GM vehicles. ³These maximum payload ratings are intended for comparison purposes only. Before you buy a vehicle or use it to haul people or cargo, carefully review the vehicle loading section of the Owner's Manual and check the carrying capacity of your specific vehicle on the label on the inside of the driver's door jamb. ⁴Capabilities and weight ratings are dependant upon model, engine, transmission and GVWR combinations. See your GMC dealer for details.

OUR REPUTATION FOLLOWS US

We believe that it's not just how much you tow, it's how well you tow that matters. That's why Sierra HD's available Duramax Diesel combined with seamlessly integrated trailering technologies generate the confidence to control heavy loads, especially in challenging situations. Because we're not only building Professional Grade trailering machines, we're building confidence in those who drive them.

GOOSENECK/FIFTH-WHEEL PREP PACKAGE Available on all cab and box types, this package includes a box-mounted seven-pin trailer harness and hitch platform to fit a gooseneck or fifth-wheel hitch for factory-installed durability.

PREMIUM TRAILERING MIRRORS The available heated, power-adjustable trailering mirrors include segment-first¹ LED rear guidance lamps. The lamps are integrated into each mirror to enhance trailer visibility when backing up. Also included are amber auxiliary clearance lamps. When equipped on All Terrain, SLT and Denali models, the mirrors include driver memory and can also power-fold to help in car washes and other tight places.

DIESEL EXHAUST BRAKE SYSTEM The available switch-activated Diesel Exhaust Brake System offers exhaust braking capability at low engine speeds. It's combined with the Allison 1000 transmission's Tow/Haul mode and Automatic Grade Braking features to reduce the amount of conventional braking needed while trailering or travelling downhill.

TRAILER BRAKE CONTROLLER For control and easy monitoring of your trailer brakes, Sierra HD offers an available integrated trailer brake controller. It's located high and in easy reach of the steering wheel for quick adjustments and is included on 2500HD SLE, SLT, Denali and all 3500HD models.



8210 KG
(18,100 LB.)

2500HD

Sierra 2500HD Regular Cab 4x2 with the available Duramax Turbo Diesel and equipped with a gooseneck or fifth-wheel hitch allows you to trailer up to 8210 kg (18,100 lb.)²

¹Comparison based on wardsauto.com 2017 Large Pickup segment and latest competitive information available at the time of printing. Excludes other GM vehicles. ²Before you buy a vehicle or use it for trailering, carefully review the trailering section of the Owner's Manual. The weight of passengers, cargo and options or accessories may reduce the amount you can tow.

REAR VISION CAMERA The centre screen serves as your monitor for the Rear Vision Camera. Its dynamic grid lines help when backing up or hitching a trailer.

TRAILER SWAY CONTROL Helps keep both Sierra HD and your trailer heading in the same direction, automatically. Sensors help detect a swaying trailer, and the system helps bring it back in line by applying both the truck's and the trailer's brakes (when properly equipped).

TOW/HAUL MODE To accelerate when trailering or hauling heavy loads, Tow/Haul mode raises transmission upshift points. It also raises downshift points using engine compression to help slow your Sierra HD instead of merely braking.

HILL START ASSIST To give you extra time to switch from the brake pedal to the accelerator on a 5 percent grade or more, Hill Start Assist holds the brakes momentarily to help prevent rolling back.

TRANSMISSION TEMPERATURE GAUGE Located in the Driver Information Centre (DIC), it allows you to monitor the transmission fluid operating temperature in real time.

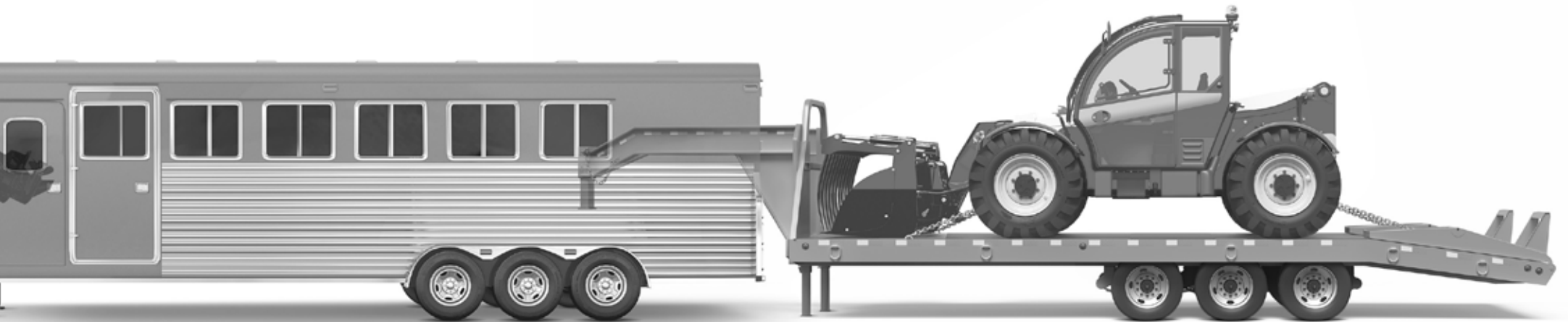

9072 KG
(20,000 LB.)

3500HD CONVENTIONAL HITCH

With the available Duramax Turbo Diesel engine, 3500HD dual-rear-wheel models offer a max conventional trailer weight rating of up to 9072 kg (20,000 lb.), when properly equipped.²

10,569 KG
(23,300 LB.)

3500HD GOOSENECK/FIFTH-WHEEL HITCH

The Sierra 3500HD Regular Cab 4x4 dual-rear-wheel model with the available Duramax Turbo Diesel and equipped with a gooseneck or fifth-wheel hitch can pull even larger equipment, up to 10,569 kg (23,300 lb.), when properly equipped.² The Double Cab, as shown, can pull up to 10,523 kg (23,200 lb.), when properly equipped.²



DESIGN

WHOEVER SAID YOU CAN'T JUDGE A BOOK BY ITS COVER NEVER LOOKED IN OUR DIRECTION. WITH STRENGTH AS A GUIDING PRINCIPLE, SIERRA HD IS HONED TO HINT AT THE CAPABILITIES THAT LIE BENEATH.

DENALI

THE PEAK

Denali is the height of premium. With Sierra HD, Denali also becomes the pinnacle of engineering and design, producing nothing short of Professional Grade capability. Its purposeful design creates an impactful presence and helps reduce wind noise for a quiet premium cabin. Not to be outdone, our most innovative cargo box also offers features to help you load and secure cargo. Choose Denali in either 3500HD or 2500HD and know you've reached the peak of GMC craftsmanship.

+ **New for 2018, the Iconic Denali Grille Makes a Powerful Statement**

+ **6" Chrome Assist Steps Serve Aesthetic and Practical Functions**

+ **Power-Folding Vertical Trailing Mirrors Help When Pulling a Wide Load** (Available 2500HD; Standard 3500HD)

+ **20" Chromed Aluminum Wheels (2500HD Models)**



SIERRA 2500 DENALI HD CREW CAB IN DARK SLATE METALLIC shown with available equipment.



QUIETLY GOES ABOUT ITS BUSINESS

The Sierra Denali HD cabin combines triple door seals, inlaid doors, specialized powertrain mounts and other engineering achievements to create an exceptionally quiet environment. It's the solitude, comfort and craftsmanship you never expected in a heavy-duty pickup. Denali is also loaded with premium materials, along with French seam stitching, supportive heated and ventilated Denali-embroidered leather-appointed front bucket seats and generous storage. A hand-stitched heated leather-wrapped steering wheel and soft-touch instrument panel with burnished aluminum trim distinguish the premium-duty Sierra Denali HD from all others.

+ **12-Way Power Front Seats With Driver Memory**

+ **Standard Driver Alert Package**

+ **Denali-Exclusive Customizable Driver Display**

+ **Bose® Premium Seven-Speaker Sound System**





SIERRA 2500 DENALI HD INTERIOR IN JET BLACK
shown with available equipment.

SLT

BOLDLY GOES WHERE YOU WANT

The first thing you notice about the Sierra SLT is its bold, precisely sculpted design that not only looks smart, but also works efficiently. The large three-dimensional grille is designed to capture air to help cool the engine, while the remaining air flows smoothly around the truck. And since it's a Sierra HD, it produces robust payload and trailering capabilities.

+ **HID Projector-Beam Headlamps**

+ **Inlaid Doors Improve Aerodynamics to Reduce Wind Noise**

+ **Chrome-Accented Mirror Caps, Chrome Front Bumper, Bodyside Mouldings and Door Handles**

+ **20" Six-Spoke Polished Aluminum Wheels** (Available on 2500HD Models)





SIERRA 3500HD CREW CAB SLT WITH DUAL REAR WHEELS IN DARK SLATE METALLIC shown with available equipment.



FUNCTIONALITY

WE ALL NEED HOBBIES. BUT WHEN IT COMES TO GETTING THE GENUINELY HARD WORK ACCOMPLISHED, WHY GO AMATEUR WHEN ONLY PROFESSIONAL GRADE WILL DO?

ALL TERRAIN



SIERRA 2500HD CREW CAB ALL TERRAIN IN DARK SLATE METALLIC shown with available equipment.

FOLLOW YOUR IMAGINATION, NOT A MAP

Canada's roads are great for taking us where we need to go. But to take us where we want to go, there's the Sierra HD All Terrain. It's available on 2500HD and 3500HD SLT Crew Cab single-rear-wheel models—all with 4x4. Sierra HD All Terrain is engineered to help you handle a variety of surfaces and conditions. So go where you want.

+ **Z71 Off-Road Suspension With Twin-Tube Rancho® Shocks**

+ **Protective Underbody Shield**

+ **Selectable Electronic 4x4 Transfer Case**

+ **Front and Rear Park Assist**

+ **Driver-Selectable Hill Descent Control**

+ **Off-Road Inclinometer in Driver Information Centre**

+ **Available 20" Polished Aluminum Wheels With Dark Argent Accents (2500HD Models)**

+ **All-Terrain Tires**

+ **Spray-On Bedliner**

+ **Exclusive All Terrain Cabin Design**

+ **Black Tubular 4" Round Assist Steps**

ALL TERRAIN X

DREAM BIGGER. A LOT BIGGER.

Enhanced capability. Trail-ready style. Signature refinement. The 2018 Sierra HD All Terrain X adds off-road style and attitude to an already bold truck. The All Terrain X Package is available on Sierra SLT 2500HD Crew Cab Standard Box 4x4 models.

All Terrain X Tires The LT275/65R18 Mud-Terrain-rated Goodyear® Wrangler DuraTrac® MT tires (shown at right) are designed for off-road competence in dirt, gravel or mud, with on-road composure in dry, wet or wintry conditions.

Black Bed-Mounted Sport Bar It's designed to support the available accessory Off-Road LED Lighting Package.¹

Engines A 6.0L V8 with Direct Injection (DI) and Variable Valve Timing (VVT) is standard. A Duramax Turbo Diesel engine with 445 hp and 910 lb.-ft. of torque is available.

PLUS:

- + **Black B-Pillar Vinyl Wrap**
- + **Black, Heated, Power-Adjustable Trailering Mirrors With Memory, Power-Folding, Integrated Turn Signals and LED Rear Guidance Lamps**
- + **18" Black Painted Aluminum Wheels**



¹Optional equipment shown. Roll bar lights are intended for off-road use only. Consult the Owner's Manual before using.



SIERRA 2500HD CREW CAB ALL TERRAIN X IN ONYX BLACK
shown with available equipment.



A

E

B

C

D

F

SIERRA 2500 DENALI HD INTERIOR IN JET BLACK
shown with available equipment.

LOOKS LIKE A COCKPIT. PERFORMS LIKE A CONTROL TOWER.

Information gives us power. That's why Sierra HD positions information where it's easy to read at a glance (gauges are LED back-lit for enhanced night viewing) and controls are within reach. Sierra also offers advanced technologies to keep you connected, informed and in control of your surroundings.

A :: ONSTAR 4G LTE WITH BUILT-IN WI-FI® HOTSPOT¹ Available 4G LTE built-in Wi-Fi (3-month or 3 GB data trial, whichever comes first) means a fast internet connection for up to seven web-enabled devices when Sierra is running. It's reliable, easy to use and can connect up to 15 metres (50 feet) around Sierra.

B :: GMC INFOTAINMENT SYSTEM² It features full-colour, 7" or available 8" diagonal screens for easy viewing and hands-free, voice-activated control of your smartphone. Stream music, sync MP3 music, receive vocalized text messages, benefit from Siri® Eyes Free³ assistance, connect libraries from multiple devices and store phone contacts.

C :: VOICE AND TOUCH-SCREEN NAVIGATION⁴ In response to your voice or touch, Sierra HD's available Navigation System⁴ displays 2-D or 3-D map graphics on the 8" diagonal centre-mounted screen. Also included, SiriusXM Traffic⁵ (with 3 trial months of SiriusXM⁵) incorporates real-time traffic and road conditions, directing you toward the most efficient route.

D :: REAR VISION CAMERA The centre screen also serves as your monitor for the Rear Vision Camera. Its dynamic grid lines help provide the perfect target when backing up or hitching a trailer.

E :: CUSTOMIZABLE DRIVER DISPLAY Denali's 8" diagonal colour Driver Information Centre (DIC) lets you choose from three selectable themes—Standard, Technology and Media—to select the information you see and how you see it. The display can be navigated with steering-wheel-mounted controls.

F :: CENTRE CONSOLE WIRELESS CHARGING MAT⁶ Available wireless charging located on the centre console lets you power up your compatible phone or device anytime the vehicle is running. No cords necessary.

¹Visit onstar.ca for coverage maps, details and system limitations. Service plan required. Available 4G LTE with Wi-Fi hotspot requires WPA2-compatible mobile device and data plan. Data plans provided by AT&T.® Services vary by model, service plan, conditions as well as geographical and technical restrictions. OnStar with 4G LTE connectivity is available on select vehicle models and in select markets. Vehicle must be started or in accessory mode to access Wi-Fi. ²Full functionality requires compatible Bluetooth® and smartphone, and USB connectivity for some devices. Data plan rates apply. ³Requires GMC Infotainment System and compatible iPhone® running iOS 6 or newer. ⁴At time of printing, detailed map coverage is available for most major urban areas of the United States and for certain metropolitan areas of Canada (Vancouver, Calgary, Edmonton, Winnipeg, Windsor, London, Toronto, Ottawa, Montreal, Quebec City and Halifax). Coverage is significantly limited outside these areas. ⁵SiriusXM satellite radio service and SiriusXM Traffic are sold separately after trial period. SiriusXM Traffic is available in select markets and requires SiriusXM satellite radio service. If you decide to continue service after your trial subscription, the plan you choose will automatically renew and bill at then-current rates until you call 1-888-539-7474 to cancel. Other fees and taxes will apply. All fees and programming subject to change. See complete terms and conditions at siriusxm.ca/terms. ⁶The vehicle must be on or Retained Accessory Power must be active. Remove all objects from the charging pad. Place the compatible mobile device face up on the charging symbol on the charging pad. Move the device slowly until the battery charging symbol displays on the touch-screen, indicating the device is charging. See your Infotainment System Owner's Manual.



SIERRA 3500 DENALI HD CREW CAB WITH DUAL REAR WHEELS IN RED QUARTZ TINTCOAT
shown with available equipment.

STOPS JUST SHORT OF LOADING ITSELF

Get to work. To help you do just that, Sierra HD offers our most innovative cargo box ever. The highlight of this collaboration between engineering and design is the widely acclaimed CornerStep rear bumper. But we didn't stop there.

CORNERSTEP REAR BUMPER AND INTEGRATED

HANDGRIPS Crafted into the corners, the bumper steps make it easy to access the cargo box. The depth of the step accommodates large boots, and ergonomically designed handgrips on the top of the side rails help give you a boost into the bed.



REMOTE POWER-LOCKING TAILGATE This available convenience allows you to lock or unlock the tailgate from the key fob.

EZ-LIFT AND LOWER TAILGATE Loading the cargo box takes less effort thanks to an available EZ-Lift and Lower Tailgate. It also keeps the tailgate from slamming down.

SPRAY-ON BEDLINER To provide a permanent, durable, nonskid surface, the available (standard on Denali, All Terrain and All Terrain X) black liner covers the entire bed below the side rails, including the tailgate, front box top rail and lower tie-down hooks. It's designed to protect Sierra's premium fit and finish.

LED UNDER-RAIL LIGHTS Available LED lights are conveniently positioned under each cargo box rail to make it easier to load or unload at night, or when the box is enclosed by a tonneau cover.



EIGHT TIE-DOWN HOOKS In addition to four lower stationary hooks are four patented, load-bearing movable upper hooks. Rated at 113 kg (250 lb.)¹ each, the upper hooks can be repositioned in several places around the box depending on the cargo being secured.

BED RAIL PROTECTION Simple yet all-too-important elements like standard rail protectors at the top of the box improve damage resistance. And to help reduce turbulence, a rear spoiler is integrated into the top of the tailgate.

HIGH-STRENGTH STEEL BED Unlike the stamped-steel process, a roll-formed process is used in Sierra HD's cargo bed floor to allow for a higher-grade steel that's stronger, lighter and more durable. Sierra HD offers a maximum payload capacity of up to 3245 kg (7153 lb.)² on 3500HD 4x2 Regular Cab models with dual rear wheels and 6.0L V8 engine.

¹Cargo and load capacity limited by weight and distribution. ²These maximum payload ratings are intended for comparison purposes only. Before you buy a vehicle or use it to haul people or cargo, carefully review the vehicle loading section of the Owner's Manual and check the carrying capacity of your specific vehicle on the label on the inside of the driver's door jamb.

YOU CAN'T BE TOO AWARE

Sierra HD elevates pickup-truck safety by offering the Driver Alert Package.

Safety features are no substitute for the driver's responsibility to operate the vehicle in a safe manner. The driver should remain attentive to traffic, surroundings and road conditions at all times. Read the vehicle Owner's Manual for important feature limitations and information.

REAR PARK ASSIST This available feature alerts you to objects behind the truck.

REAR VISION CAMERA The centre screen serves as your monitor for the Rear Vision Camera. Its dynamic grid lines help when backing up or hitching a trailer.



¹Always use safety belts and the correct restraint for your child's age and size. Even in vehicles equipped with the Passenger Sensing System, children are safer when properly secured in a rear seat in the appropriate infant, child or booster seat. Never place a rear-facing infant restraint in the front seat of any vehicle equipped with a passenger airbag. See the Owner's Manual and child safety seat instructions for more safety information.

SAFETY ALERT SEAT This available seat warns you of potential traffic danger using directional vibration pulses from the seat cushion. Works with Forward Collision Alert, Lane Departure Warning and Front and Rear Park Assist.



LANE DEPARTURE WARNING It's available to alert you when Sierra HD drifts over a lane line without signalling while travelling at least 56 km/h (35 mph).

FRONT PARK ASSIST This available feature alerts you to objects in front of the truck.

FORWARD COLLISION ALERT To help you prevent frontal crashes, this available technology alerts you when you are closing in on a vehicle ahead too quickly.

AIRBAGS* Sierra HD offers up to six airbags (standard on 2500HD and select 3500HD models), including frontal, head-curtain with rollover protection and front-seat-mounted side-impact airbags.

BECAUSE NOT JUST ANY WHEELS WILL DO

Building a premium-duty truck like the 2018 Sierra HD means engineering every millimetre of it from the ground up—including the wheels it rides on. That's why you'll find a selection of GMC wheels in a range of styles and sizes for your Sierra HD. See your dealer for more availability details.

2500HD WHEELS



17" PAINTED STEEL (PYN)
Standard on 2500HD Sierra



18" PAINTED STEEL (PYT)
Available on 2500HD Sierra



17" MACHINED ALUMINUM (PYQ)
Standard on 2500HD SLE;
Available on 2500HD Sierra



18" CHROMED ALUMINUM (PYR)
Standard on 2500HD SLT; Included on
2500HD All Terrain; Available on 2500HD SLE



18" BLACK PAINTED ALUMINUM (RT4)
Included and only available with
All Terrain X Package



20" 5-SPOKE POLISHED ALUMINUM (PYU)
Available on 2500HD SLE



20" 6-SPOKE POLISHED ALUMINUM (Q7R)
Available on 2500HD SLT



20" 5-SPOKE POLISHED ALUMINUM
WITH DARK ARGENT ACCENTS (RTH)
Available on 2500HD All Terrain

DENALI HD SRW WHEELS



20" CHROMED ALUMINUM (RQA)
Standard on 2500 Denali HD



18" CHROMED ALUMINUM (PYR)
Standard on 3500 Denali HD;
Available on 2500 Denali HD

3500HD SRW WHEELS



18" PAINTED STEEL (PYT)
Standard on 3500HD Sierra



18" CHROMED ALUMINUM (PYR)
Standard on 3500HD SLE and SLT;
Included on 3500HD All Terrain

3500HD DRW WHEELS



17" PAINTED STEEL (PYW)
Standard on 3500HD Sierra



17" PAINTED STEEL WITH CHROME OVERLAY (P06)
Standard on 3500HD SLE and SLT



17" POLISHED FORGED ALUMINUM (RS7)
Standard on 3500 Denali HD;
Available on 3500HD Crew Cab SLE and SLT

ACCESSORIES

DIY

Go ahead, equip your Sierra HD exactly the way you want. Engineered to the same Professional Grade standards as your Sierra HD, GMC Accessories range from functional enhancements such as assist steps and storage systems to stylish accents.





GOOSENECK HITCH COMPLETION PACKAGE Tow heavy loads confidently with your Sierra HD using this available gooseneck hitch completion package.



PREMIUM ALL-WEATHER FLOOR LINERS Sierra's available floor liners take all-weather floor mat coverage further with raised edges to help protect floor and trim contours.



STATIONARY TOOLBOX This available diamond-patterned toolbox features a cover with dual gas shocks for smooth opening and closing, and it features the GMC logo.



TONNEAU COVERS The available soft cover shields cargo and easily rolls up to allow full access to the bed. The available hard cover is tri-folding and adds strong content protection.

INSTRUMENT PANEL ACCENTS



Axiom Aluminum



Dark Aluminum



Burnished Aluminum

DOOR AND CONSOLE ACCENTS

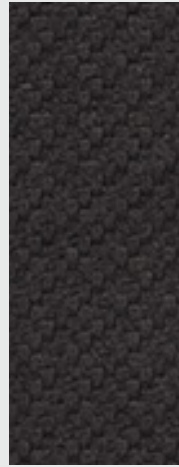

Off-Road Carbon Accent



Mineral Caster Wood Tone

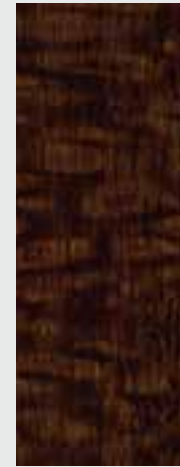

Grand Lace Wood Tone

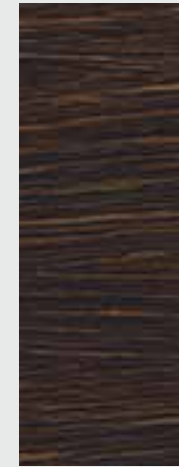

Oblique Hanon Oak Wood Tone

**INTERIOR COLOURS/
SEATING SURFACES**
VINYL CLOTH

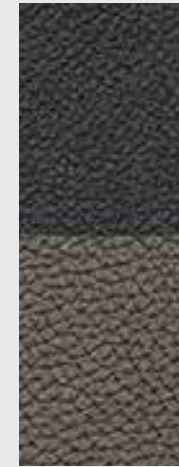

Jet Black/Dark Ash

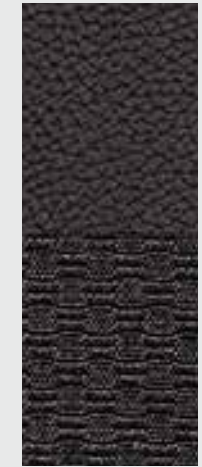

Jet Black/Jet Black

MODELS

MODEL	Axiom Aluminum	Dark Aluminum	Burnished Aluminum	Off-Road Carbon Accent	Mineral Caster Wood Tone	Grand Lace Wood Tone	Oblique Hanon Oak Wood Tone	Jet Black/Dark Ash	Jet Black/Jet Black
SIERRA	-	-	-	-	-	-	-	○	●
SLE	●	-	-	-	● ¹	● ²	-	-	●
SLT	●	-	-	-	● ¹	● ²	-	-	-
ALL TERRAIN	-	●	-	●	-	-	-	-	-
DENALI	-	-	●	-	-	-	●	-	-

KEY ● STANDARD ○ AVAILABLE - NOT AVAILABLE

EXTERIOR COLOURS [See your GMC dealer for more exterior colour details and availability.]

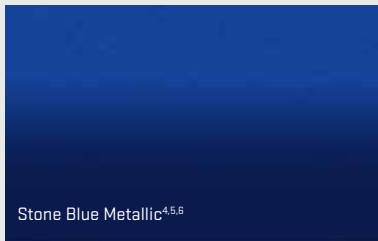

Stone Blue Metallic^{4,5,6}

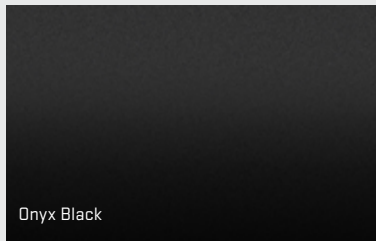

Onyx Black



Quicksilver Metallic⁵

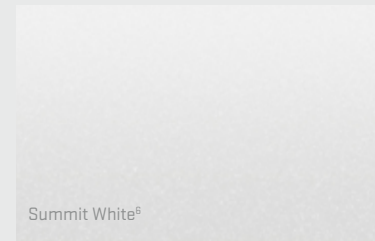

Summit White⁶

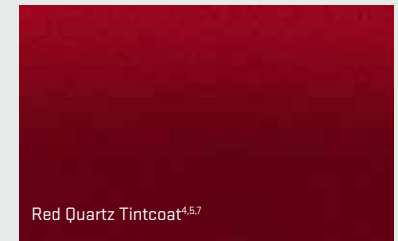

Red Quartz Tintcoat^{4,5,7}

¹With Cocoa/Dune interior colour only. ²With Jet Black and Jet Black/Dark Ash interior colour only. ³Includes unique Denali accents. ⁴Additional charge, premium paint. ⁵Not available with All Terrain Package or All Terrain X Package. ⁶Not available on Denali. ⁷Not available on base Sierra trim. ⁸Denali models only. ⁹Crew Cab model only.

LEATHER APPOINTMENTS



Jet Black/Dark Ash Cocoa/Dune Jet Black/Jet Black Jet Black/Jet Black Perforated Jet Black/Jet Black with Spice Red Accents Jet Black/Dark Ash Jet Black/Dark Ash Perforated Cocoa/Dune Cocoa/Dune Perforated Cocoa/Dark Sand Perforated

-	-	-	-	-	-	-	-	-	-
●	●	○	-	-	-	-	-	-	-
-	-	●	○	-	●	○	●	○	-
-	-	-	-	●	-	-	-	-	-
-	-	-	● ³	-	-	-	-	-	● ³

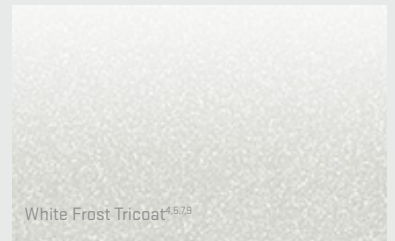
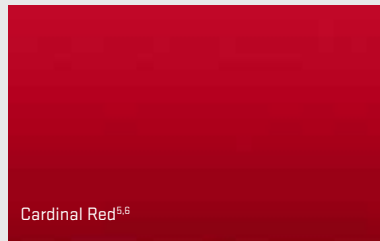

SIERRA HD SPECIFICATIONS

CARGO DIMENSIONS¹

DIMENSIONS	STANDARD BOX	LONG BOX SRW	LONG BOX DRW
Cargo Volume, litres (cu. ft.)	1727 (61.0)	2161 (76.3)	2161 (76.3)
Inside Width at Floor, mm (in.)	1296 (51.0)	1296 (51.0)	1296 (51.0)
Box Length at Floor, mm (in.)	2003 (78.9)	2483 (97.8)	2483 (97.8)
Inside Box Height, mm (in.)	539 (21.2)	539 (21.2)	542 (21.3)
EXTERIOR DIMENSIONS	REGULAR CAB	DOUBLE CAB	CREW CAB
Height, mm (in.)	1950-1979 (76.8-77.9) ²	1972-1984 (77.6-78.1) ²	1975-1990 (77.8-78.3) ²
Overall Length, mm (in.)			
Standard Box	—	5842 (230.0)	6083 (239.5)
Long Box	5701 (224.4)	6322 (248.9)	6563 (258.4)
INTERIOR DIMENSIONS, mm (in.)	REGULAR CAB	DOUBLE CAB	CREW CAB
Head Room (front/rear)	1087/— (42.8/—)	1087/982 (42.8/38.6)	1087/1029 (42.8/40.5)
Leg Room (front/rear)	1150/— (45.2/—)	1150/880 (45.2/34.6)	1150/1040 (45.2/40.9)
Shoulder Room (front/rear)	1677/— (66.0/—)	1647/1634 (64.8/64.3)	1647/1634 (64.8/64.3)
Hip Room (front/rear)	1543/— (60.7/—)	1543/1530 (60.7/60.2)	1543/1530 (60.7/60.2)
WHEELBASE, mm (in.)	REGULAR CAB	DOUBLE CAB	CREW CAB
Standard Box	—	3663 (144.2)	3904 (153.7)
Long Box	3393 (133.6)	4016 (158.1)	4260 (167.7)

STANDARD TECHNICAL DATA

Series/Drive Type	4x2	4x4
BRAKES All models: Power 4-wheel anti-lock braking system	14" diameter 4-wheel disc (includes Duralife rotors)	14" diameter 4-wheel disc (includes Duralife rotors)
STEERING	Power recirculating ball with Smart Flow System	Power recirculating ball with Smart Flow System
FUEL TANK CAPACITY, litres (imp. gal) (approx.)	136 (30)	136 (30)
ALTERNATOR (amps)	150	150
MAXIMUM GVWR, ³ kg (lb.) (Gross Vehicle Weight Rating)	VORTEC 6.0L V8/DURAMAX 6.6L V8 TURBO DIESEL	
	REGULAR CAB	DOUBLE CAB
2500HD		
Standard Box	—/—	4309/4536 (9500/10,000)
Long Box	4309/4491 (9500/9900)	4309/4536 (9500/10,000)
3500HD		
SRW	4854/5171 (10,700/11,400)	4990/5262 (11,000/11,600)
DRW	6123/5908 (13,500/13,025)	5908/5908 (13,025/13,025)
	DOUBLE CAB	CREW CAB

¹Cargo and load capacity limited by weight and distribution. ²Depending on model and tire size selected. ³When properly equipped; includes weight of vehicle, passengers, cargo and equipment. ⁴Capacities and weight ratings are dependant on model, engine, transmission and GVWR combinations. See your GMC dealer for details.

ENGINES

	VORTEC 6.0L V8 VVT (L96)	DURAMAX 6.6L V8 TURBO DIESEL (L5P)
FUEL TYPE	Gasoline	Diesel (B20 biodiesel capable)
CAPACITY	6.0 litres (364 cu. in.)	6.6 litres (402 cu. in.)
SAE NET HORSEPOWER @ RPM	330 @ 4600	445 @ 2800
SAE NET TORQUE (LB.-FT.) @ RPM	380 @ 4200	910 @ 1600
ENGINE/MODEL AVAILABILITY		
Regular Cab	●	○
Double Cab	●	○
Crew Cab	●	○

SIERRA HD SUSPENSIONS

FRONT SUSPENSIONS⁴

INDEPENDENT TORSION BAR—2500HD/3500HD

STANDARD FRONT AXLE/ SPRING CAPACITY, kg (lb.)	4x2	4x4
Regular Cab	1996/1996 (4400/4400)	1996/1996 (4400/4400)
Double Cab	1996/1996 (4400/4400)	1996/2177 (4400/4800)
Crew Cab	1996/1996 (4400/4400)	2177/2177 (4800/4800)

REAR SUSPENSIONS⁴

SEMI-ELLIPTICAL MULTILEAF—2500HD/3500HD-SRW/3500HD-DRW

REAR AXLE/SPRING CAPACITY, kg (lb.)	4x2	4x4
Regular Cab	2812/3198/4457 (6200/7050/9825)	2812/3198/4457 (6200/7050/9825)
Double Cab	2812/3198/4252 (6200/7050/9375)	2812/3198/4252 (6200/7050/9375)
Crew Cab	2812/3198/4252 (6200/7050/9375)	2812/3198/4252 (6200/7050/9375)

SIERRA HD SPECIFICATIONS (CONTINUED)

CONVENTIONAL TRAILER WEIGHT RATINGS,¹ kg (lb.) (Based on SAE J2807 performance requirements)

Model	Engine	Axle Ratio	GCWR ²	2500HD Standard Box 4x2 SRW	2500HD Long Box 4x2 SRW	3500HD Standard Box 4x2 SRW	3500HD Long Box 4x2 SRW	3500HD Long Box 4x2 DRW	2500HD Standard Box 4x4 SRW	2500HD Long Box 4x4 SRW	3500HD Standard Box 4x4 SRW	3500HD Long Box 4x4 SRW	3500HD Long Box 4x4 DRW
Regular Cab	Vortec 6.0L V8	4.10	9571 (21,100)	—	6577 (14,500)	—	6577 (14,500)	6486 (14,300)	—	6577 (14,500)	—	6486 (14,300)	6350 (14,000)
	Duramax 6.6L V8 Turbo Diesel	3.73	11,476 (25,300)	—	6577 (14,500)	—	—	—	—	6577 (14,500)	—	6577 (14,500)	—
		3.73	14,197 (31,300)	—	—	—	—	—	—	—	—	—	9072 (20,000)
Double Cab	Vortec 6.0L V8	4.10	9571 (21,100)	5897 (13,000)	6532 (14,400)	—	6441 (14,200)	6260 (13,800)	5897 (13,000)	6396 (14,100)	—	6305 (13,900)	6169 (13,600)
	Duramax 6.6L V8 Turbo Diesel	3.73	11,476 (25,300)	5897 (13,000)	6577 (14,500)	—	6577 (14,500)	—	5897 (13,000)	6577 (14,500)	—	6577 (14,500)	—
		3.73	14,197 (31,300)	—	—	—	—	9072 (20,000)	—	—	—	—	9072 (20,000)
Crew Cab	Vortec 6.0L V8	4.10	9571 (21,100)	5897 (13,000)	6486 (14,300)	5897 (13,000)	6396 (14,100)	6214 (13,700)	5897 (13,000)	6305 (13,900)	5897 (13,000)	6214 (13,700)	6078 (13,400)
	Duramax 6.6L V8 Turbo Diesel	3.73	11,476 (25,300)	5897 (13,000)	6577 (14,500)	5897 (13,000)	6577 (14,500)	—	5897 (13,000)	6577 (14,500)	5897 (13,000)	6804 (15,000)	—
		3.73	14,197 (31,300)	—	—	—	—	9072 (20,000)	—	—	—	—	9072 (20,000)

SRW-Single Rear Wheel DRW-Dual Rear Wheel

FIFTH-WHEEL/GOOSENECK TRAILER WEIGHT RATINGS,¹ kg (lb.) (Based on SAE J2807 performance requirements)

Model	Engine	Axle Ratio	GCWR ²	2500HD Standard Box 4x2 SRW	2500HD Long Box 4x2 SRW	3500HD Standard Box 4x2 SRW	3500HD Long Box 4x2 SRW	3500HD Long Box 4x2 DRW	2500HD Standard Box 4x4 SRW	2500HD Long Box 4x4 SRW	3500HD Standard Box 4x4 SRW	3500HD Long Box 4x4 SRW	3500HD Long Box 4x4 DRW
Regular Cab	Vortec 6.0L V8	4.10	9571 (21,100)	—	6713 (14,800)	—	6622 (14,600)	6486 (14,300)	—	6577 (14,500)	—	6486 (14,300)	6305 (13,900)
	Duramax 6.6L V8 Turbo Diesel	3.73	11,476 (25,300)	—	8210 (18,100)	—	—	—	—	7212 (15,900)	—	7983 (17,600)	—
		3.73	14,197 (31,300)	—	—	—	—	—	—	—	—	—	10,569 (23,300)
Double Cab	Vortec 6.0L V8	4.10	9571 (21,100)	6577 (14,500)	6532 (14,400)	—	6441 (14,200)	6260 (13,800)	6441 (14,200)	6396 (14,100)	—	6305 (13,900)	6123 (13,500)
	Duramax 6.6L V8 Turbo Diesel	3.73	11,476 (25,300)	7439 (16,400)	7121 (15,700)	—	7938 (17,500)	—	6532 (14,400)	6214 (13,700)	—	7802 (17,200)	—
		3.73	14,197 (31,300)	—	—	—	—	10,523 (23,200)	—	—	—	—	10,387 (22,900)
Crew Cab	Vortec 6.0L V8	4.10	9571 (21,100)	6486 (14,300)	6441 (14,200)	6441 (14,200)	6350 (14,000)	6214 (13,700)	6350 (14,000)	6305 (13,900)	6305 (13,900)	6214 (13,700)	6033 (13,300)
	Duramax 6.6L V8 Turbo Diesel	3.73	11,476 (25,300)	6985 (15,400)	6713 (14,800)	7938 (17,500)	7893 (17,400)	—	6123 (13,500)	5625 (12,400)	7802 (17,200)	7711 (17,000)	—
		3.73	14,197 (31,300)	—	—	—	—	10,478 (23,100)	—	—	—	—	10,297 (22,700)

SRW-Single Rear Wheel DRW-Dual Rear Wheel ¹Before you buy a vehicle or use it for trailering, carefully review the trailering section of the Owner's Manual. The weight of passengers, cargo and options or accessories may reduce the amount you can tow. ²Gross Combined Weight Rating. When properly equipped, includes weight of the vehicle and trailer combination, including the weight of the driver, passengers, fuel, optional equipment and cargo in the vehicle and trailer.

AXLE RATINGS AND PLOW WEIGHTS

FRONT GROSS AXLE WEIGHT RATING (FGAWR) WITH SNOW PLOW PREP PACKAGE, kg (lb.) (4x4 MODELS ONLY)

NOTE: All models are capable of up to 45 kg (100 lb.) maximum of permanently attached snow plow mounting hardware.

Model	Engine RPO	Engine Type	2500HD SRW	3500HD SRW	3500HD DRW
Regular Cab	L96	Gas	2359 (5200)	2540 (5600)	2540 (5600)
	L5P	Diesel	2722 (6000)	2722 (6000)	2722 (6000)
Double Cab Standard Box/Long Box	L96	Gas	2359/2540 (5200/5600)	—/2540 (—/5600)	—/2540 (—/5600)
	L5P	Diesel	2722/2722 (6000/6000)	—/2722 (—/6000)	—/2722 (—/6000)
Crew Cab Standard Box/Long Box	L96	Gas	2359/2540 (5200/5600)	2540/2540 (5600/5600)	—/2540 (—/5600)
	L5P	Diesel	2722/2722 (6000/6000)	2722/2722 (6000/6000)	—/2722 (—/6000)

MAXIMUM PLOW WEIGHTS,³ kg (lb.) (4x4 MODELS ONLY)

Model	Engine RPO	Engine Type	2500HD SRW	3500HD SRW	3500HD DRW
Regular Cab	L96	Gas	408 (900)	454 (1000)	454 (1000)
	L5P	Diesel	442 (975)	442 (975)	420 (925)
Double Cab Standard Box/Long Box	L96	Gas	352/454 (775/1000)	—/454 (—/1000)	—/454 (—/1000)
	L5P	Diesel	374/352 (825/775)	—/363 (—/800)	—/352 (—/775)
Crew Cab Standard Box/Long Box	L96	Gas	329/431 (725/950)	454/431 (1000/950)	—/420 (—/925)
	L5P	Diesel	352/318 (775/700)	363/329 (800/725)	—/318 (—/700)

SRW-Single Rear Wheel DRW-Dual Rear Wheel ³Maximum weight, kg (lb.) of removable snow plow blade and blade hardware. Maximum plow weights based on a vehicle with average manufacturer option content and 68 kg (150 lb.) each for driver and one additional front-seat occupant. Additional equipment and occupants will reduce maximum plow weight. Rear compensating weight may be required to maintain front axle weight below 65% of total vehicle weight when equipped with snow plow. Consult your snow plow manufacturer for specific compensating weight recommendation.

MAXIMUM PAYLOAD,¹ kg (lb.)

Model	Engine	GVWR ²	2500HD Standard Box 4x2 SRW	2500HD Long Box 4x2 SRW	3500HD Standard Box 4x2 SRW	3500HD Long Box 4x2 SRW	3500HD Long Box 4x2 DRW	2500HD Standard Box 4x4 SRW	2500HD Long Box 4x4 SRW	3500HD Standard Box 4x4 SRW	3500HD Long Box 4x4 SRW	3500HD Long Box 4x4 DRW	
Regular Cab	Vortec 6.0L V8	4218 (9300)	—	1603 (3534)	—	—	—	—	—	—	—	—	
		4309 (9500)	—	—	—	—	—	—	1547 (3410)	—	—	—	
		4717 (10,400)	—	—	—	1991 (4390)	—	—	—	—	—	—	
		4854 (10,700)	—	—	—	—	—	—	—	—	1978 (4361)	—	
		6078 (13,400)	—	—	—	—	—	—	—	—	—	3050 (6724)	
		6124 (13,500)	—	—	—	—	3245 (7153)	—	—	—	—	—	
	Duramax 6.6L V8 Turbo Diesel	4490 (9900)	—	1453 (3204)	—	—	—	—	1306 (2880)	—	—	—	—
		5171 (11,400)	—	—	—	—	—	—	—	—	1919 (4230)	—	—
		5908 (13,025)	—	—	—	—	—	—	—	—	—	2503 (5518)	—
Double Cab	Vortec 6.0L V8	4309 (9500)	1534 (3381)	1486 (3276)	—	—	—	1403 (3093)	1355 (2987)	—	—	—	
		4854 (10,700)	—	—	—	1926 (4246)	—	—	—	—	—	—	
		4990 (11,000)	—	—	—	—	—	—	—	—	1935 (4267)	—	
		5908 (13,025)	—	—	—	—	2828 (6235)	—	—	—	—	2701 (5955)	
	Duramax 6.6L V8 Turbo Diesel	4536 (10,000)	1339 (2951)	1290 (2845)	—	—	—	1207 (2662)	1160 (2557)	—	—	—	—
		5080 (11,200)	—	—	—	1776 (3916)	—	—	—	—	—	—	—
		5262 (11,600)	—	—	—	—	—	—	—	—	—	1831 (4036)	—
		5908 (13,025)	—	—	—	—	2451 (5404)	—	—	—	—	—	2324 (5124)
		5908 (13,025)	—	—	—	—	—	—	—	—	—	—	—
Crew Cab	Vortec 6.0L V8	4309 (9500)	1466 (3233)	1425 (3141)	—	—	—	1335 (2943)	—	—	—	—	
		4490 (9900)	—	—	—	—	—	—	1445 (3186)	—	—	—	
		4763 (10,500)	—	—	1838 (4052)	—	—	—	—	—	—	—	
		4854 (10,700)	—	—	—	1871 (4124)	—	—	—	—	—	—	
		4899 (10,800)	—	—	—	—	—	—	—	1841 (4058)	—	—	
		4990 (11,000)	—	—	—	—	—	—	—	—	1848 (4074)	—	
		5908 (13,025)	—	—	—	—	2772 (6112)	—	—	—	—	2613 (5761)	
	Duramax 6.6L V8 Turbo Diesel	4536 (10,000)	1271 (2803)	1230 (2711)	—	—	—	1140 (2513)	1069 (2356)	—	—	—	—
		5035 (11,100)	—	—	1733 (3821)	—	—	—	—	—	—	—	—
		5171 (11,400)	—	—	—	1811 (3993)	—	—	—	—	—	—	—
		5216 (11,500)	—	—	—	—	—	—	—	1781 (3927)	—	—	—
		5262 (11,600)	—	—	—	—	—	—	—	—	1743 (3843)	—	—
5908 (13,025)	—	—	—	—	2395 (5281)	—	—	—	—	—	2236 (4930)		

¹These maximum payload ratings are intended for comparison purposes only. Before you buy a vehicle or use it to haul people or cargo, carefully review the vehicle loading section of the Owner's Manual and check the carrying capacity of your specific vehicle on the label on the inside of the driver's door jamb. ²Gross Vehicle Weight Rating [GVWR]. When properly equipped; includes weight of vehicle, passengers, cargo and equipment.

	SIERRA	SLE	SLT	ALL TERRAIN	DENALI
CONFIGURATIONS					
REGULAR CAB	○	○	-	-	-
DOUBLE CAB	○	○	○	-	-
CREW CAB	○	○	○	●	●
4X2	○	○	○	-	-
4X4	○	○	○	●	●
DUAL REAR WHEELS (DRW)	○	○	○	-	○
MECHANICAL					
AIR FILTER High capacity	●	●	●	●	●
ALTERNATOR 150 amps	●	●	●	●	●
220 amps. Included with the Snow Plow Prep Package.	○	○	○	○	○
Dual, 150 amps and 220 amps each. Requires Duramax 6.6L V8 Turbo Diesel engine.	○	○	○	○	○
AUXILIARY EXTERNAL TRANSMISSION OIL COOLER	●	●	●	●	●
AUXILIARY EXTERNAL ENGINE OIL COOLER	●	●	●	●	●
BATTERY Heavy-duty maintenance-free with rundown protection and retained accessory power. Includes dual batteries with Duramax 6.6L V8 Turbo Diesel engine.	●	●	●	●	●
AUXILIARY BATTERY 730 Cold Cranking Amps (CCA). Requires Vortec 6.0L V8 VVT engine.	○	○	○	○	○
BRAKES 4-wheel disc with 4-wheel anti-lock (includes Duralife brake rotors)	●	●	●	●	●
CAPLESS FUEL FILL Not available with Duramax 6.6L V8 Turbo Diesel or Box Delete	●	●	●	●	●
COLD-WEATHER PROVISIONS Includes front radiator grille and front bumper openings cover. Requires Duramax 6.6L V8 Turbo Diesel engine.	○	○	○	○	○
FRAME Fully boxed with hydroformed front section	●	●	●	●	●
ENGINE Vortec 6.0L V8 VVT with SFI	●	●	●	●	●
Duramax 6.6L V8 Turbo Diesel with Direct Injection and B20 biodiesel capability. On 2500HD SLT Crew Cab and Denali models, included and only available with Duramax Plus Package.	○	○	○	○	○
ENGINE BLOCK HEATER Included with Duramax 6.6L V8 Turbo Diesel engine	○	○	○	○	○
EXHAUST Aluminized stainless-steel muffler and tailpipe	●	●	●	●	●
EXHAUST BRAKE Switch activated. Included and only available with Duramax 6.6L V8 Turbo Diesel engine.	○	○	○	○	○
HIGH IDLE SWITCH	○	○	○	○	○
HILL DESCENT CONTROL Included and only available with Z71 Off-Road Suspension Package	-	○	○	●	●
INTEGRATED TRAILER BRAKE CONTROLLER Included on all 3500HD models. On 2500HD Sierra models, included and only available with Trailering Equipment Package.	○	●	●	●	●
STABILITRAK STABILITY CONTROL SYSTEM Includes Proactive Roll Avoidance, traction control, electronic Trailer Sway Control and Hill Start Assist	●	●	●	●	●
STEERING Power, recirculating ball with Smart Flow system	●	●	●	●	●
Digital Steering Assist. Requires Double Cab with 6.6L V8 Turbo Diesel engine or Crew Cab model.	-	●	●	●	●

KEY ● STANDARD ○ AVAILABLE - NOT AVAILABLE

	SIERRA	SLE	SLT	ALL TERRAIN	DENALI
SUSPENSION Front independent with torsion bars. Includes 33 mm front stabilizer bar.					
51 mm twin-tube shock absorbers	●	●	●	●	●
Twin-tube Rancho®-brand shock absorbers. Included and only available with Z71 Off-Road Suspension Package.	-	○	○	●	○
Rear multileaf springs, semielliptical with urethane jounce bumpers	●	●	●	●	●
TRANSMISSION 6L90-E 6-speed automatic. Includes Tow/Haul mode, Cruise Grade Braking and Powertrain Grade Braking.	●	●	●	●	●
Allison® 1000 Series 6-speed automatic. Includes Tow/Haul mode and electronic Powertrain Grade Braking. Requires Duramax 6.6L V8 Turbo Diesel engine.	○	○	○	○	○
TRANSFER CASE 2-speed with 2.72-to-1 low-range, floor-mounted shifter (4x4 models only)	●	-	-	-	-
Electronic shift rotary dial controls 2-speed and 2.72-to-1 low-range (4x4 models only)	-	●	●	●	●
TRAILER WIRING PROVISIONS For camper, gooseneck and fifth-wheel trailer. Includes additional 7-way wiring harness located at rear of pickup box. Requires Trailering Equipment Package.	○	○	○	○	○
REAR AXLE 4.10 ratio. Requires Vortec 6.0L V8 engine.	●	●	●	●	●
3.73 ratio. Requires Duramax 6.6L V8 Turbo Diesel engine.	○	○	○	○	○
EATON® HEAVY-DUTY AUTOMATIC LOCKING REAR DIFFERENTIAL	●	●	●	●	●
INSTRUMENTATION AND CONTROLS					
DRIVER INFORMATION CENTRE With 3.5" diagonal monochromatic display. Provides warning messages, odometer, trip odometer and basic vehicle information.	●	-	-	-	-
With 4.2" diagonal colour display. Includes driver personalization, warning messages, odometer, trip odometer and vehicle information.	-	●	●	●	-
8" diagonal colour customizable display	-	-	-	-	●
POWER-ADJUSTABLE PEDALS On SLE trim, included and only available with SLE Convenience Package. Not available on Regular Cab.	-	○	●	●	●
110-VOLT POWER OUTLET In-cabin, 3-prong, household-style outlet. On Sierra trim, included and only available with Sierra Convenience Package or Sierra Convenience Plus Package. On SLE trim, included and only available with the SLE Preferred Package or SLE Preferred Plus Package.	○	○	●	●	●
STEERING WHEEL Polyurethane with cruise controls	●	-	-	-	-
Leather-wrapped with audio and cruise controls	-	●	●	-	-
Heated and leather-wrapped with audio and cruise controls	-	-	○	●	●
STEERING COLUMN Tilt-Wheel, manual operation	●	●	-	-	-
Tilt-Wheel and telescopic manual operation. On SLE trim, included and only available with SLE Preferred Package or SLE Preferred Plus Package.	-	○	●	●	●
TEEN DRIVER A configurable feature that lets you activate customizable vehicle settings associated with a key fob, to encourage safe driving behaviour. It can limit certain vehicle features, and it prevents certain safety systems from being turned off, if equipped. An in-vehicle report card gives you information on your teen's driving habits and helps you to continue to coach your new driver.	●	●	●	●	●
TIRE PRESSURE MONITORING SYSTEM Includes Tire Fill Alert on all Single Rear Wheel models. Does not monitor spare tire.	●	●	●	●	●

	SIERRA	SLE	SLT	ALL TERRAIN	DENALI
SEATING					
SEATS Front 3-passenger cloth 40/20/40 split bench with driver and front-passenger manual recline, manual driver lumbar control and outboard head restraints. Includes centre fold-down armrest with storage.	●	-	-	-	-
Front 3-passenger vinyl 40/20/40 split bench with driver and front-passenger manual recline and outboard head restraints. Includes centre fold-down armrest with storage.	○	-	-	-	-
Front 3-passenger cloth 40/20/40 split bench with driver and front-passenger manual recline, manual driver lumbar control and outboard head restraints. Includes centre fold-down armrest and lockable storage compartment in lower seat cushion.	-	●	-	-	-
Front 3-passenger leather-appointed 40/20/40 split bench with heated seat cushions and seatbacks. Not available on Regular Cab models. Requires Jet Black interior trim and SLE Preferred Package or SLE Preferred Plus Package.	-	○	-	-	-
Front 3-passenger leather-appointed 40/20/40 split bench with 10-way power seat adjusters. Includes power lumbar control, heated seat cushions and seatbacks, 2-position driver memory (does not apply to lumbar adjuster) and adjustable head restraints.	-	-	●	-	-
Front cloth bucket seats with 10-way driver-seat power adjuster, 6-way passenger-seat power adjuster, heated seat cushions and seatbacks, adjustable head restraints, floor console and storage pockets. Not available on Regular Cab models.	-	○	-	-	-
Front leather-appointed bucket seats with 10-way power seat adjusters including power lumbar control, heated seat cushions and seatbacks, 2-position driver memory (does not apply to lumbar adjuster), adjustable head restraints and floor console and storage pockets	-	-	○	●	-
Seat adjuster, driver 10-way power. Requires bench seat. Included and only available with SLE Preferred Package or SLE Preferred Plus Package.	-	○	-	-	-
Heated driver and front-passenger cloth seating. Requires SLE Preferred Package and cloth 40/20/40 split bench seat. Not available on Regular Cab models.	-	○	-	-	-
Heated and ventilated perforated leather-appointed front bucket seats. On Denali trim, includes embroidered Denali logo on front seats and 12-way driver and front-passenger power adjuster, including power lumbar control.	-	-	○	-	●
Folding rear 3-passenger bench. Double Cab models only. Includes child seat top tether anchor.	●	-	-	-	-
Folding rear 60/40 split 3-passenger bench. Includes child seat top tether anchor. On Sierra trim, Crew Cab models only. On SLE and SLT trims, Double and Crew Cab models only.	●	●	●	●	●

	SIERRA	SLE	SLT	ALL TERRAIN	DENALI
INTERIOR DETAILS					
AUXILIARY SWITCH BANK Includes 4 upfitter switches	○	-	-	-	-
CLIMATE CONTROL Single-zone manual air conditioning	●	●	-	-	-
Dual-zone automatic climate control. On SLE trim, included and only available with SLE Preferred Package or SLE Preferred Plus Package. Not available on Regular Cab models.	-	○	●	●	●
CRUISE CONTROL	●	●	●	●	●
DEFOGGER Rear-window electric. On SLE trim, included and only available with SLE Preferred Package, SLE Preferred Plus Package or SLE Convenience Package.	○	○	●	●	●
DOOR LOCKS Power	●	●	●	●	●
FLOOR COVERING Graphite-coloured rubberized vinyl	●	○	-	-	-
Rubberized vinyl floor mats (Double and Crew Cab models include second-row floor mats)	○	●	-	-	-
Colour-keyed carpeting	○	●	●	●	●
Colour-keyed carpeted floor mats	-	-	●	-	●
All-weather floor liners (dealer-installed). On SLE trim, included with SLE Preferred Plus Package.	○	○	○	●	○
REMOTE VEHICLE STARTER SYSTEM On SLE trim, included and only available with SLE Preferred Package or SLE Preferred Plus Package	-	○	●	●	●
REMOTE KEYLESS ENTRY On Sierra trim, included and only available with Sierra Convenience Package or Sierra Convenience Plus Package. Includes remote locking tailgate.	○	●	●	●	●
REAR-VIEW MIRROR With manual day/night adjustment	●	●	-	-	-
With auto-dimming feature. Included and only available with outside heated, power-adjustable vertical trailing mirrors on 2500HD SLE and 3500HD with Sierra trim.	○	○	●	●	●
SILL PLATES Bright accent	-	-	-	●	●
SUNROOF Power sliding with express-open. Crew Cab models only. Not available with provisions for roof-mounted lamps/beacon or Snow Plow Prep Package.	-	-	○	○	○
UNIVERSAL HOME REMOTE On SLE trim, included and only available with SLE Preferred Package or SLE Preferred Plus Package. Not available on Regular Cab models, provisions for roof-mounted lamps/beacon or Snow Plow Prep Package.	-	○	●	●	●
WINDOWS Manual. Standard on Sierra Regular Cab only.	●	-	-	-	-
Power with driver express-up and -down and express-down on all other windows. Standard on all Double and Crew Cab models. On Sierra Regular Cab model, included and only available with Sierra Convenience Package.	○	●	●	●	●
Power rear sliding with rear defogger. Not available on Regular Cab models, provisions for roof-mounted lamps/beacon or Snow Plow Prep Package. On SLE trim, included and only available with SLE Convenience Package. On 2500HD SLT model, included with 2500HD SLT Gas Premium Plus Package.	-	○	○	○	●
WIRELESS CHARGING MAT¹ Centre console-mounted. Requires Crew Cab or Double Cab models. Included and only available with front bucket seats. Not compatible with all devices.	-	○	○	●	●

¹The vehicle must be on or Retained Accessory Power must be active. Remove all objects from the charging pad. Place the compatible mobile device face up on the charging symbol on the charging pad. Move the device slowly until the battery charging symbol displays on the touch-screen, indicating the device is charging. See your Infotainment System Owner's Manual.

	SIERRA	SLE	SLT	ALL TERRAIN	DENALI
--	--------	-----	-----	-------------	--------

OPTION PACKAGES

ALL TERRAIN X HD PACKAGE Requires 2500HD Crew Cab Standard Box model. Includes 18" black painted aluminum wheels, LT 275/65R18 MT blackwall Goodyear® Wrangler DuraTrac® tires, black bed-mounted sport bar, power-adjustable heated power-folding trailering mirrors with integrated turn signals, cargo lamp, amber clearance lamps, black mirror caps, black front-bumper skid plate and black B-pillar vinyl wrap.	-	-	-	○	-
2500HD SLT GAS PREMIUM PLUS PACKAGE Includes Front and Rear Park Assist, heated steering wheel, power sliding rear window, 6" rectangular chrome tubular assist steps, Bose® premium sound system, 8" diagonal Colour Touch audio system with GMC Infotainment System ¹ with Navigation, ² exterior memory-equipped heated power-adjustable vertical trailering mirrors with chrome caps, front leather-appointed bucket seats and spray-on bedliner. Requires Vortec 6.0L V8 engine. Not available with provisions for cab roof-mounted lamps/beacon or Snow Plow Prep Package.	-	-	○	-	-
DURAMAX PLUS PACKAGE Includes Duramax 6.6L V8 Turbo Diesel engine, Allison 1000 6-speed transmission and exterior memory-equipped heated power-adjustable vertical trailering mirrors with chrome caps. On SLT trim, includes Bose premium sound system, Front and Rear Park Assist and 8" diagonal colour touch-screen with Navigation. ² Requires 2500HD Crew Cab model. On Denali trim, includes chrome recovery hooks.	-	-	○	○	○
SIERRA CONVENIENCE PACKAGE Includes exterior heated power-adjustable mirrors, remote keyless entry, remote locking tailgate, 110-volt AC power outlet, LED cargo box lighting and deep-tinted glass. Includes power windows on Regular Cab models.	○	-	-	-	-
SIERRA CONVENIENCE PLUS PACKAGE Requires gas-engine Crew Cab models. Includes black exterior heated power-adjustable vertical trailering mirrors, remote keyless entry, remote locking tailgate, 110-volt power outlet, OnStar Guidance Plan, OnStar 4G LTE with Wi-Fi® hotspot, ³ LED cargo box lighting, deep-tinted glass, integrated trailer brake controller and Trailering Equipment Package. Not available with Sierra Convenience Package.	○	-	-	-	-
SLE CONVENIENCE PACKAGE Includes power-adjustable pedals, Rear Park Assist, power sliding rear window and rear-window defogger. When provisions for cab roof-mounted lamps/beacon or Snow Plow Prep Package are ordered, the power sliding rear window will not be included. Not available on Regular Cab models.	-	○	-	-	-
SLE PREFERRED PACKAGE Includes driver 10-way power seat adjuster with front 40/20/40 split bench seat only. Also includes Remote Vehicle Starter System, fog lamps, rear-window defogger, manual tilt-and-telescopic steering column and 110-volt power outlet. Also includes Universal Home Remote and dual-zone automatic climate control on Double Cab and Crew Cab models. When provisions for cab roof-mounted lamps/beacon or Snow Plow Prep Package are ordered, the Universal Home Remote will not be included.	-	○	-	-	-
SLE PREFERRED PLUS PACKAGE Requires gas-engine Double Cab or Crew Cab models. Includes driver 10-way power seat adjuster when ordered with front 40/20/40 split bench seat only, black exterior heated power-adjustable vertical trailering mirrors (2500HD models only), Remote Vehicle Starter System, fog lamps, rear-window defogger, dual-zone automatic climate control, Universal Home Remote, manual tilt-and-telescopic steering wheel, 110-volt power outlet, spray-on bedliner and all-weather floor liners. When provisions for cab roof-mounted lamps/beacon or Snow Plow Prep Package are ordered, Universal Home Remote will not be included. Not available with SLE Preferred Package.	-	○	-	-	-
DRIVER ALERT PACKAGE Includes Lane Departure Warning, Forward Collision Alert, Safety Alert Seat and Front and Rear Park Assist. On SLT trim, requires heated and ventilated driver and front-passenger seating, full-feature leather-appointed bucket seats and heated steering wheel. On SLE trim, requires Regular Cab with Jet Black cloth interior and SLE Preferred Package. On 3500HD SLT models, also requires front-seat-mounted side-impact and front and rear head-curtain airbags. ⁴	-	○	○	-	●
Z71 OFF-ROAD SUSPENSION PACKAGE Includes Hill Descent Control, underbody shields, twin-tube Rancho-brand shocks, Z71 front fender emblems (All Terrain door badge in lieu of Z71 emblem on All Terrain model) and off-road Driver Information Centre graphics. Single Rear Wheel 4x4 models only.	-	○	○	●	○
TRAILERING EQUIPMENT PACKAGE Includes trailer hitch platform 2.5" with a 2.0" insert, 7-wire harness with independent fused trailering circuits mated to a 7-way sealed connector to hook up parking lamps, back-up lamps, turn signals, an electric brake lead, battery and a ground. Connector also includes the 4-way blade-style connector. On 2500HD Sierra models, included with Sierra Convenience Plus Package. Includes trailer brake controller. Included on 3500HD models. Not available with rear bumper delete or box delete.	○	●	●	●	●
GOOSENECK/FIFTH-WHEEL PREP PACKAGE Includes hitch platform to accept gooseneck ball, drilled box holes and box-mounted trailer harness with connector. Requires Trailering Equipment Package, spray-on bedliner and trailering mirrors.	○	○	○	○	○

KEY ● STANDARD ○ AVAILABLE - NOT AVAILABLE

	SIERRA	SLE	SLT	ALL TERRAIN	DENALI
--	--------	-----	-----	-------------	--------

SNOW PLOW PREP PACKAGE Includes power feed for back-up and roof emergency light, 220-amp alternator, forward lamp wiring harness, provisions for cab roof-mounted lamps/beacon, Underbody Shield Package and increased Front Gross Axle Weight Rating (FGAWR). 4x4 models only. Alternator upgradeable to dual, 150 amps and 220 amps each with Duramax 6.6L Turbo Diesel V8 engine. See your dealer for more details.

UNDERBODY SHIELD PACKAGE Includes frame-mounted shields, front underbody shield starting behind front bumper and running to first cross member, helping to protect the front underbody, oil pan, differential case and transfer case. Included with Snow Plow Prep Package or Z71 Off-Road Suspension Package.

PROVISIONS FOR CAB ROOF-MOUNTED LAMPS/BEACON Includes instrument-panel-mounted switch and electrical wiring tucked beneath the headliner for body upfitter to connect a body-mounted warning or emergency lamp. Included with Snow Plow Prep Package. Not available with Universal Home Remote or power sunroof.

ENTERTAINMENT/COMMUNICATION/NAVIGATION

7" DIAGONAL COLOUR TOUCH-SCREEN WITH GMC INFOTAINMENT SYSTEM¹ Includes AM/FM, USB ports,⁵ auxiliary jack, Bluetooth®⁵ streaming audio for music and select phones, hands-free smartphone integration and voice-activated technology for radio and phone

8" DIAGONAL COLOUR TOUCH-SCREEN WITH GMC INFOTAINMENT SYSTEM¹ Includes AM/FM/SiriusXM⁶ (standard for 3 months)/HD Radio, USB ports,⁵ auxiliary jack, Bluetooth⁵ streaming audio for music and select phones, hands-free smartphone integration and voice-activated technology for radio and phone

8" DIAGONAL COLOUR TOUCH-SCREEN WITH GMC INFOTAINMENT SYSTEM¹ WITH NAVIGATION² Includes all features of 8" diagonal Colour Touch Radio plus Navigation² feature

Single-slot CD/MP3 player

6-SPEAKER SOUND SYSTEM

Bose premium sound system with 6 speakers (7-speaker system including subwoofer when ordered with bucket seats)

REAR-SEAT DVD ENTERTAINMENT SYSTEM Includes rear-seat Blu-ray™/DVD player with 9.2" diagonal LCD display, 2 sets of digital wireless headphones, HDMI connector, OnStar 4G LTE with built-in Wi-Fi hotspot³ capability with select devices, Video Voice Over, 2 USB ports⁵ and A/V remote control. Requires front bucket seats and Bose premium sound system. Replaces single-slot CD/MP3 player. Crew Cab models only.

BLUETOOTH⁵ For phone, personal cellphone connectivity to vehicle audio system

ONSTAR Basic Plan⁷ for 5 years

ONSTAR GUIDANCE PLAN 6-month trial period, including a 3 GB or 3-month data plan trial, whichever comes first

ONSTAR 4G LTE WITH WI-FI HOTSPOT³ CAPABILITY

SIRIUSXM⁶ Including 3 trial months of service

EXTERIOR STYLING AND FUNCTIONALITY

ASSIST STEPS Chromed tubular with 6" rectangular design. On 2500HD SLT model, included with SLT Gas Premium Plus Package. On 3500HD SLT model, required with Dual Rear Wheel Diesel model.

Black tubular 4" round

BUMPER Front, chrome. Includes chrome skid plate on SLT models.

Rear, chrome CornerStep bumper

Front, body-colour. Includes black lower bumper fascia on All Terrain models and chrome skid plate on Denali models.

Rear, body-colour CornerStep bumper

ROOF MARKER LAMPS Included with dual-rear-wheel models. Optional on single-rear-wheel models.

○	○	○	○	○
○	○	○	●	●
○	○	○	○	○
●	-	-	-	-
-	●	●	●	-
-	○	○	○	●
-	●	●	●	●
●	●	●	-	-
-	-	○	○	○
●	●	●	●	●
○	●	●	●	●
○	●	●	●	●
○	○	○	-	●
-	-	-	●	-
●	●	●	-	-
●	●	●	-	-
-	-	-	●	●
-	-	-	●	●
○	○	○	○	○

	SIERRA	SLE	SLT	ALL TERRAIN	DENALI
CARGO BOX Movable tie-downs, high-mounted (4)	●	●	●	●	●
Box rail caps	●	●	●	●	●
DOOR HANDLES Black	●	-	-	-	-
Body-colour	-	●	-	●	-
Chrome	-	-	●	-	●
FOG LAMPS Halogen. On SLE trim, included and only available with SLE Preferred Package or SLE Preferred Plus Package.	-	○	●	●	●
GRILLE SURROUND Chrome	●	●	●	-	●
Chrome-accented centre	-	●	●	-	-
Body-colour with All Terrain black and chrome grille insert	-	-	-	●	-
Chrome with unique Denali accents	-	-	-	-	●
GLASS Solar-Ray tinted	●	-	-	-	-
Solar-Ray deep-tinted. On Sierra trim, included and only available with Sierra Convenience Package or Sierra Convenience Plus Package.	○	●	●	●	●
LIGHTS High-Intensity Discharge (HID) projector-beam headlamps. Includes GMC signature LED lighting.	●	●	●	●	●
Under-rail LED lighting, cargo box. On Sierra trim, included and only available with Sierra Convenience Package or Sierra Convenience Plus Package.	○	●	●	●	●
MOULDINGS Bodyside, body-colour	-	●	-	●	-
Bodyside, chrome	-	-	●	-	●
RECOVERY HOOKS Front frame-mounted (black)	●	●	●	●	●
SPRAY-ON BEDLINER	○	○	○	●	●
TAILGATE Locking	●	-	-	-	-
Remote locking. On Sierra trim, included and only available with remote keyless entry, Sierra Convenience Package or Sierra Convenience Plus Package.	○	●	●	●	●
EZ-Lift and Lower feature	-	●	●	●	●
TIRE CARRIER Exterior spare, winch-type. Includes lock.	●	●	●	●	●
WHEELHOUSE LINERS Rear. Single Rear Wheel Double Cab and Crew Cab models only.	-	●	●	●	●
WIPERS Front intermittent	●	●	●	●	●
EXTERIOR MIRRORS					
Manual-folding, black (2500HD models only)	●	-	-	-	-
Heated, power-adjustable, manual-folding, black (2500HD models only). On Sierra trim, included and only available with Sierra Convenience Package. Mirror caps are body-colour on SLE trim.	○	●	-	-	-
Heated, power-adjustable/power-folding. With integrated turn-signal indicators, security approach lamps, driver-side auto-dimming and puddle lamps (2500HD models only). Includes chrome mirror caps on SLT and Denali models. Includes black mirror caps on All Terrain models.	-	-	●	●	●

	SIERRA	SLE	SLT	ALL TERRAIN	DENALI
VERTICAL TRAILERING Black, vertical trailing mirrors with manual folding and extension and lower convex spotter glass. Standard on 3500HD models. Requires Trailing Package on 2500HD models. Not available with Sierra Convenience Package.	○	-	-	-	-
Black, heated, power-adjustable vertical trailing mirrors with manual folding and extension, lower convex spotter glass, integrated turn-signal indicators, rear guidance lamps and amber auxiliary clearance lamps. On 2500HD Sierra model, requires Sierra Convenience Package when Sierra Convenience Plus Package is not ordered. On 3500HD Sierra model, included and only available with Sierra Convenience Package or Sierra Convenience Plus Package. Includes auto-dimming interior rear-view mirror. On 2500HD SLE model, includes auto-dimming interior rear-view mirror. Standard on 3500HD SLE models.	○	○	-	-	-
Chrome cap, heated, power-adjustable vertical trailing mirrors with power folding, manual extension, driver memory, lower convex spotter glass, integrated turn-signal indicators, rear guidance lamps and amber auxiliary clearance lamps. Included with 2500HD SLT Gas Premium Plus Package and Duramax Plus Package. Standard on 3500HD SLT and Denali models. Mirror caps are black on All Terrain and All Terrain X models.	-	-	○	○	○

SAFETY AND SECURITY

AIRBAGS¹ Single-stage frontal for driver and front passenger on all 3500HD models and 2500HD Crew Cab models. Includes dual-stage front-passenger airbag with infant-only Passenger Sensing System on 2500HD Regular Cab and 2500HD Double Cab models with a pickup box.	●	●	●	●	●
Front-seat-mounted side-impact driver and right front-passenger airbags for thorax and pelvis protection. Included on all 2500HD and select 3500HD models. See your dealer for more details and availability.	○	○	○	○	●
Front and rear head-curtain airbags for all outboard seating positions. Included on all 2500HD models. See your dealer for more details and availability.	○	○	○	○	●
DAYTIME RUNNING LAMPS With automatic lamp control	●	●	●	●	●
LANE DEPARTURE WARNING Included and only available with Driver Alert Package. On SLE trim, requires Regular Cab.	-	○	○	-	●
FORWARD COLLISION ALERT Included and only available with Driver Alert Package. On SLE trim, requires Regular Cab.	-	○	○	-	●
REAR PARK ASSIST Ultrasonic. On Double Cab and Crew Cab models, included and only available with SLE Convenience Package.	-	○	-	-	-
FRONT AND REAR PARK ASSIST Ultrasonic. On SLE trim, included and only available on Regular Cab models with Driver Alert Package.	-	○	○	●	●
REAR VISION CAMERA With dynamic grid lines	●	●	●	●	●
SAFETY ALERT SEAT Included and only available with Driver Alert Package. On SLE trim, requires Regular Cab.	-	○	○	-	●
THEFT-DETERRENT SYSTEM Unauthorized entry. On SLE trim, included and only available with Remote Vehicle Starter System.	-	○	●	●	●

¹Full functionality requires compatible Bluetooth and smartphone, and USB connectivity for some devices. Data plan rates apply. ²At time of printing, detailed map coverage is available for most major urban areas of the United States and for certain metropolitan areas of Canada (Vancouver, Calgary, Edmonton, Winnipeg, Windsor, London, Toronto, Ottawa, Montreal, Quebec City and Halifax). Coverage is significantly limited outside these areas. ³Visit onstar.ca for coverage maps, details and system limitations. Service plan required. Available 4G LTE with Wi-Fi hotspot requires WPA2-compatible mobile device and data plan. Data plans provided by AT&T.® Services vary by model, service plan, conditions as well as geographical and technical restrictions. OnStar with 4G LTE connectivity is available on select vehicle models and in select markets. Vehicle must be started or in accessory mode to access Wi-Fi. ⁴Always use safety belts and the correct restraint for your child's age and size. Even in vehicles equipped with the Passenger Sensing System, children are safer when properly secured in a rear seat in the appropriate infant, child or booster seat. Never place a rear-facing infant restraint in the front seat of any vehicle equipped with a passenger airbag. See the Owner's Manual and child safety seat instructions for more safety information. ⁵Not compatible with all devices. ⁶Available in 10 Canadian provinces, three territories and the 48 contiguous United States. Subscription sold separately after trial period. If you decide to continue your service at the end of your trial subscription, the plan you choose will automatically renew and bill at then-current rates until you call 1-888-539-7474 to cancel. Other fees and taxes will apply. All fees and programming subject to change. See SiriusXM "Terms & Conditions" and complete details at siriusxm.ca/terms. ⁷The OnStar Basic Plan is available on eligible new vehicles for 5 years and is transferable to subsequent owners for the remaining term. It includes the monthly Diagnostics Report emails (capabilities vary by model), Dealer Maintenance Notification, access to select vehicle mobile app features and more. This plan does not include emergency, security or navigation services. These and other services require a paid or Add-On Plan. Visit onstar.ca for vehicle availability, coverage maps, details and system limitations. Available 4G LTE with Wi-Fi hotspot requires WPA2-compatible mobile device and data plan. Data plans are provided by AT&T.

EVEN OUR PROTECTION IS HEAVY-DUTY

Pro Grade Protection is standard on every 2018 Sierra HD. From maintenance to protecting your entire vehicle, you can drive with confidence.

- + 2-Year/48,000 km Lube-Oil-Filter Maintenance¹
- + 3-Year/60,000 km New-Vehicle Limited Warranty²
- + 5-Year/160,000 km Powertrain Limited Warranty²
- + 5-Year/160,000 km Roadside Assistance/Courtesy Transportation²



¹Whichever comes first. Limit of four complimentary Lube-Oil-Filter services in total. Fluid top-offs, inspections, tire rotations, wheel alignments and balancing, etc., are not covered. Conditions and limitations apply. See your dealer for details. ²Whichever comes first. Conditions and limitations apply; see your dealer for details.



WE'RE AS CLOSE AS THE BLUE BUTTON

Connect to an OnStar¹ Advisor just by pushing the blue OnStar button in your Sierra HD. Most 2018 Sierra HD models include the OnStar Basic Plan² for 5 years (available on base Sierra trim), plus a limited service trial of the Guidance Plan (available on base Sierra trim) that includes a comprehensive suite of emergency, security, navigation and diagnostic services.

EMERGENCY: HELP WHEN IT MATTERS MOST. With Automatic Crash Response,³ you can be immediately connected to the help you need the moment you need it, even if you can't ask for it. If you're stranded, have a flat tire or need a tow truck, use Roadside Assistance⁴ and an OnStar Advisor will locate a nearby service provider and direct them to your exact location.

SECURITY: IT CAN HELP RECOVER YOUR VEHICLE IF IT'S EVER STOLEN. Breathe easy knowing a comprehensive suite of Stolen Vehicle Assistance⁵ services is available to help recover your vehicle. With Theft Alarm Notification,⁶ OnStar can alert you if your vehicle's alarm is sounding, and if your vehicle is stolen, OnStar will work with authorities to help locate and recover it quickly.

NAVIGATION: TRAVEL MADE EASY. Turn-by-Turn Navigation⁷ makes everywhere you go as familiar as your own neighbourhood. And with OnStar AtYourService,⁸ an Advisor can help you book a hotel room on the go.

CONNECTIONS: FAST AND RELIABLE. Stay connected almost anywhere, anytime with the built-in Wi-Fi hotspot¹ and connect up to seven devices at fast speed.

VEHICLE MANAGER: PREPARING YOU FOR WHAT'S AHEAD. Enjoy the ultimate ownership experience with your myGMC mobile app.⁹ Use Remote Access¹⁰ to start your engine, lock and unlock your doors, honk the horn and flash the lights from anywhere there is cellphone service. Get real-time Diagnostic Alerts¹¹ or a monthly diagnostics report of the vehicle's engine, transmission and more with Advanced Diagnostics.¹¹

¹Visit onstar.ca for coverage maps, details and system limitations. Service plan required. Available 4G LTE with Wi-Fi hotspot requires WPA2-compatible mobile device and data plan. Data plans provided by AT&T. Services vary by model, service plan, conditions as well as geographical and technical restrictions. OnStar with 4G LTE connectivity is available on select vehicle models and in select markets. Vehicle must be started or in accessory mode to access Wi-Fi. ²The OnStar Basic Plan is available on eligible new vehicles for 5 years and is transferable to subsequent owners for the remaining term. It includes the monthly Diagnostics Report emails (capabilities vary by model), Dealer Maintenance Notification, access to select vehicle mobile app features and more. This plan does not include emergency, security or navigation services. These and other services require a paid or Add-On Plan. Visit onstar.ca for vehicle availability, coverage maps, details and system limitations. Available 4G LTE with Wi-Fi hotspot requires WPA2-compatible mobile device and data plan. Data plans are provided by AT&T. ³Visit onstar.ca for vehicle availability, details and system limitations. OnStar acts as a link to existing emergency service providers. Not all vehicles may transmit all crash data. ⁴Roadside service provided by Allstate Roadside Services. Limitations and restrictions apply. ⁵Service varies by model and conditions. Visit onstar.ca for details and system limitations. Stolen Vehicle Slowdown and Remote Ignition Block are available on select 2009 and newer GM vehicles. ⁶Capability varies by model, conditions as well as geographical and technical restrictions. Visit onstar.ca for vehicle availability, details and system limitations. Requires factory-installed theft-deterrent system and Security or Guidance plan or Stolen Vehicle Assistance Add-On Plan and selected notification preference[s]. Vehicles must be locked electronically to arm the factory-installed theft-deterrent system. Messaging and data rates may apply. ⁷Requires Basic Plan and navigation system to send directions through the mobile app. Turn-by-Turn directions and Destination Download also available through an Advisor with the Guidance Plan or Navigation Add-On Plan. Visit onstar.ca for coverage maps. Services vary by model. ABS required. ⁸Not available on Basic Plan. Hotel booking and billing done through Priceline.⁹ Offers may vary. Check AtYourService through a blue OnStar button press for latest offers. ¹⁰Available on select Apple[®] and Android[™] devices. Some features may require a paid OnStar service plan. Features and capability may vary by vehicle, device, conditions as well as geographical and technical restrictions. Device data connection required. ¹¹Visit onstar.ca for coverage maps, details and system limitations. Services vary by model, conditions as well as geographical and technical restrictions. Unlock feature requires automatic locks. Remote start requires factory-installed and enabled remote-start system. ¹²Availability and capabilities vary by model. Visit onstar.ca for details and system limitations. Message and data rates may apply. Requires active OnStar service, email address on file and enrolment in Advanced Diagnostics which may include access to the monthly Diagnostics Report emails, Diagnostic and Proactive Alerts, Dealer Maintenance Notification and On-Demand Diagnostics [requires paid service plan]. Other factors may affect vehicle performance. Not all issues will deliver alerts. In certain scenarios, a dealer service check may be required to confirm the accuracy of the Diagnostic and Proactive Alerts.

CONVERSATION STARTER

At GMC, we'd like to start a dialogue with you so we can learn more about each other. Join the conversation and share your passion for all things Professional Grade.



GMCCANADA.CA



IMPORTANT WORDS

PEACE OF MIND, STANDARD WITH EVERY GMC MODEL

When you build them with quality, you can back them with confidence. That's why General Motors of Canada backs every GMC model with the best coverage in Canada. Program highlights include:

- 2-year/48,000 km Lube-Oil-Filter Maintenance¹
- 3-year/60,000 km New-Vehicle Limited Warranty²
- 5-year/160,000 km Powertrain Limited Warranty, with \$0 deductible on repairs and the warranty is fully transferable at no charge²
- 5-year/160,000 km Courtesy Transportation²
- 5-year/160,000 km 24/7 Roadside Assistance²
- 6-year/160,000 km rust-through perforation coverage²
- 8-year/130,000 km coverage on catalytic converters and Powertrain Control Modules (PCMs)²

OTHER OWNERSHIP PRIVILEGES AND PROGRAMS:³

- **GM Protection Plan (GMPP)**—The only extended service plan backed by the resources and commitment of General Motors, GMPP may be purchased at the time of sale or subsequently during the New-Vehicle Limited Warranty period.
- **Certified Service**—With GM-certified technicians and GM-approved parts, nobody knows your GM vehicle better.
- **GMC Owner Centre**—As an owner, take advantage of the GMC Owner Centre. This online owner's destination gives you access to contests, current offers and helpful resources such as Owner's Manuals. Find out more at gmcowner.ca.

TO HELP YOU PURCHASE OR LEASE A NEW VEHICLE:

- **Purchase Financing and Leasing**—On-the-spot financing, see dealer for full details.⁴
- **GM Student Bonus Program**—Students or recent graduates of high school, college or university³ may be eligible to receive a Student Bonus vehicle redemption allowance of \$500 or \$750⁵ (tax inclusive) (purchased vehicle dependant) to use toward the purchase, lease or finance of one eligible new GMC vehicle.
- **GM Card**—Cardholders may redeem Earnings toward the total purchase price or lease down payment of an eligible new GMC truck or SUV. Restrictions and limitations apply.⁵ For full program details, visit gmccard.ca.

INFORMATION RESOURCES:

You can find more information about these programs from your GMC dealer, or at these information centres:

- The GM website at gmccanada.ca
- The GM Customer Care Centre at 1-800-GM-DRIVE (1-800-463-7483 or 1-800-263-3830 for TDD users)

A WORD ABOUT THIS BROCHURE

Some of the equipment shown or described throughout this brochure may be available at extra cost. We have tried to make this brochure comprehensive and factual. We reserve the right, however, to make changes at any time, without notice, in prices, colours, materials, equipment, specifications, models and availability. Specifications, dimensions, measurements, ratings and other numbers in this brochure and other printed materials provided at the dealership or affixed to vehicles are approximates based upon design and engineering drawings and prototypes and laboratory tests. Your vehicle may differ due to variations in manufacture and equipment. Since some information may have been adapted since the time of printing, please check with your GMC dealer for complete details. General Motors of Canada Company reserves the right to lengthen or shorten the model year for any product, for any reason, or to start and end model years at different times.

A WORD ABOUT ASSEMBLY

GMC vehicles are equipped with engines and components produced and assembled by different operating units of General Motors, its subsidiaries and suppliers to GM worldwide. We sometimes find it necessary to produce GMC vehicles with different or differently sourced components than originally scheduled. Since some options may be unavailable when your vehicle is assembled, we suggest that you verify that your vehicle includes the equipment you ordered or, if there are changes, that they are acceptable to you.

TRADEMARKS

©2017 General Motors of Canada Company. All rights reserved. The marks appearing in this brochure, including but not limited to: General Motors, GM, GMC, Sierra and their respective logos, emblems, slogans and vehicle model names and body designs; and other marks such as StabiliTrak are trademarks of General Motors and/or General Motors of Canada Company, its subsidiaries, affiliates or licensors. OnStar and the OnStar emblem are registered trademarks of OnStar, LLC. SiriusXM, the SiriusXM logo, channel names and logos are trademarks of SiriusXM Radio Inc. and are used under licence. Bluetooth is a registered trademark of Bluetooth SIG, Inc. Bose is a registered trademark of the Bose Corporation. Apple, Siri and iPhone are registered trademarks of Apple, Inc. Apple CarPlay is a trademark of Apple, Inc. Android and Android Auto are trademarks of Google Inc. Goodyear is a registered trademark of Goodyear Canada Inc. DuraTrac is a registered trademark of the Goodyear Tire & Rubber Company. Rancho is a registered trademark of Tenneco Automotive Operating Company, Inc.

¹Whichever comes first. Limit of four complimentary Lube-Oil-Filter services in total. Fluid top-offs, inspections, tire rotations, wheel alignments and balancing, etc., are not covered. Conditions and limitations apply. See your dealer for details. ²Whichever comes first. Conditions and limitations apply; see your dealer for details. ³Conditions and limitations apply. ⁴Subject to eligibility. ⁵Program subject to change.

