

2018

**YUKON**

---





# DISTINCTIVE LIKE A PRO

Premium. It's everywhere you look, touch and experience in the 2018 Yukon. EcoTec3 engines offer proven V8 power plus efficiency, while the suspension is engineered for uncompromising ride and handling. Inside, a quiet well-appointed cabin welcomes you with premium materials and intuitive technologies. They are reminders that the same passion and purpose that drive you also drive us. We're setting our own standards and proving that Professional Grade isn't merely a label, it's a way of life. Yukon is the latest example of how we take a bold stance for what we believe in and pursue it like a pro.



YUKON XL SLT IN WHITE FROST TRICOAT (left)  
YUKON DENALI IN IRIDIUM METALLIC (right)  
shown with available equipment.  
A preproduction model is shown on the front cover.  
Actual production models may vary.







# DESIGN

WHEN IT COMES TO DESIGNING THE STANDARD-BEARER OF PREMIUM SUVs, THERE'S A DIFFERENCE BETWEEN STANDING OUT AND STICKING OUT. TASTEFUL CURVES, DIGNIFIED LINES AND ATTENTION TO DETAIL DEFINE YUKON.



YUKON DENALI INTERIOR IN COCOA/DARK ATMOSPHERE  
shown with available equipment.



YUKON XL DENALI IN WHITE FROST TRICOAT  
shown with available equipment.





# DENALI

## THIS IS OUR EXCLAMATION POINT

The ultimate expression of Professional Grade arrives in the form of Yukon Denali. Inside, premium surroundings abound thanks to authentic materials—burnished aluminum trim and new Mastique Ash wood grains and perforated first- and second-row Mulan leather-appointed seating. Outside, signature Denali styling begins with its new satin-chrome-finished grille, projector-beam High-Intensity Discharge (HID) headlamps and front and rear GMC signature C-shaped LED lighting and continues with available 22" wheels and optional power-retractable assist steps with perimeter lighting.

+ **New Distinctive Denali Grille**

+ **Power-Retractable Assist Steps With LED Perimeter Lighting (Available)**

+ **Burnished Aluminum Trim**

+ **Contrasting French Seam Stitching**

+ **Mastique Ash Wood Grains**

+ **Perforated First- and Second-Row Leather-Appointed Seating and Heated/Ventilated Driver and Front-Passenger Seats**

+ **Active Noise Cancellation**



# SLT

## SMOOTH. VERY SMOOTH.

Yukon SLT was designed for efficient aerodynamics. Bold, sculpted lines glide from the three-dimensional grille and over the inlaid doors for smooth, uninterrupted airflow. The seamless design continues inside with an abundance of authentic materials and ergonomically designed gauges and controls, as well as seating that keeps you and your passengers comfortable every mile of your journey. To complete the exterior design, the liftgate spoiler conceals the rear wiper to reduce drag for optimal efficiency.

- + Inlaid Doors Reduce Wind Noise
- + Acoustically Laminated Windshield and Front Door Glass Enhance Quietness
- + Push-Button Keyless Entry and Push-Button Start
- + Tri-Zone Automatic Climate Controls
- + Power-Adjustable Pedals
- + Front Heated and Ventilated Perforated Leather-Appointed Seating and Second-Row Heated Seats (Outboard Only)
- + 12-Way Power Driver and Front-Passenger Seat Adjuster
- + SLT Premium Edition Includes All of the Above Plus Uniquely Designed 22" Chrome Wheels, Bright Chrome Bodyside Mouldings, Chrome Grille and Polished Exhaust Tip



YUKON SLT INTERIOR IN COCOA/DUNE  
shown with available equipment.



YUKON SLT PREMIUM EDITION IN CRIMSON RED TINTCOAT (left)  
YUKON XL SLT IN QUICKSILVER METALLIC (right)  
shown with available equipment.







DENALI

GMC





# ENGINEERING

FROM GENERATING POWER EFFICIENTLY TO SMOOTHING OUT YOUR RIDE,  
THE DRIVING FORCE BEHIND YUKON RESULTS IN AN OVERWHELMING FEELING OF CONFIDENCE.



YUKON DENALI IN SATIN STEEL METALLIC  
shown with available equipment.



## HANDLES THE STRAIGHT AND NARROW. AND THE TWISTS AND TURNS.

Behind the wheel of Yukon, you'll feel confident and in command of the renowned EcoTec3 engine technologies while you and your passengers enjoy a comfortable ride. Yukon Denali goes a step further by adding Magnetic Ride Control (illustrated below), a suspension that speed-reads the road up to 1,000 times a second, thinks and responds to road changes before you ever could.

### CRUISING

On smooth roads, the iron particles in the patented magnetorheological fluid align to allow for a smooth ride.



### CONTROLLED

During cornering or on uneven surfaces, a magnetic field realigns the particles for a more secure, precise driving experience.

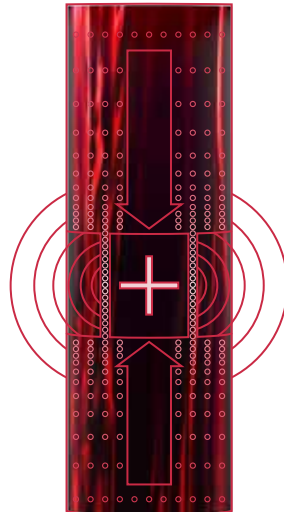

## A POSITION OF STRENGTH

From Yukon's fully boxed frame to its EcoTec3 engine family, it is engineered to put you in a constant position of strength, power and efficiency.

**ECOTEC3 ENGINES** They use Direct Injection (DI), Active Fuel Management and continuously Variable Valve Timing (VVT) to deliver exceptional power, efficiency and durability. At an estimated 10.4 L/100 km highway 4x2,<sup>1</sup> the 5.3L V8 scores the best V8 highway fuel efficiency in its class<sup>2</sup> For more performance, Yukon Denali's 6.2L V8 produces a class-leading<sup>2</sup> 420 hp and 460 lb.-ft. of torque.

**ACTIVE AERO GRILLE SHUTTERS** Grille shutters automatically close to maximize aerodynamic efficiency when conditions are right. The shutters are designed to remain open in situations where maximum airflow is needed.

**TRANSMISSIONS** The 5.3L V8 features a 6-speed and the 6.2L V8 is paired with a new 10-speed automatic transmission. They both offer the control of a manual and the ease of an automatic with Driver Shift Control.

**MAGNETIC RIDE CONTROL** On Yukon Denali, it senses changes in the road up to 1000 times a second, instantly adjusting each shock absorber for maximum comfort, control and agility.

**CORROSION-RESISTANT DURALIFE BRAKE ROTORS** GMC engineers used patented Ferritic Nitro-Carburizing (FNC) technology that can help double rotor life.

**FOUR-WHEEL DRIVE** Yukon's available four-wheel-drive system allows you to switch between two-wheel drive for optimum fuel efficiency and four-wheel drive for additional traction and control.

**FOUR-WHEEL DISC BRAKES** The stopping system improves pedal feel for a stronger, more confident braking performance.

**FULLY BOXED FRAME** Yukon's frame is constructed with 75 percent high-strength steel for maximum people- and cargo-carrying capability.

**ELECTRIC VARIABLE-ASSIST POWER STEERING** The electric variable-assist power rack-and-pinion steering system improves fuel efficiency versus engine-powered systems.

**SHEAR-STYLE BODY MOUNTS** Connecting the body to the frame are high lateral-rate and hydraulic body mounts. They provide additional comfort and a smoother, quieter ride.



ACTIVE AERO GRILLE SHUTTERS

ECOTEC3 ENGINES

MAGNETIC RIDE CONTROL (DENALI)

TRANSMISSION

ELECTRIC VARIABLE-ASSIST POWER STEERING

<sup>1</sup>Estimated 15.1 L/100 km city 4x2. Fuel-consumption estimates based on GM preliminary testing in accordance with Government of Canada approved test methods. Refer to [vehicles.nrcan.gc.ca](http://vehicles.nrcan.gc.ca) for details. Your actual fuel consumption may vary. <sup>2</sup>Comparison based on [wardsauto.com](http://wardsauto.com) 2017 Large Sport/Utility Vehicle segment and latest competitive information available at time of printing. Excludes other GM vehicles.



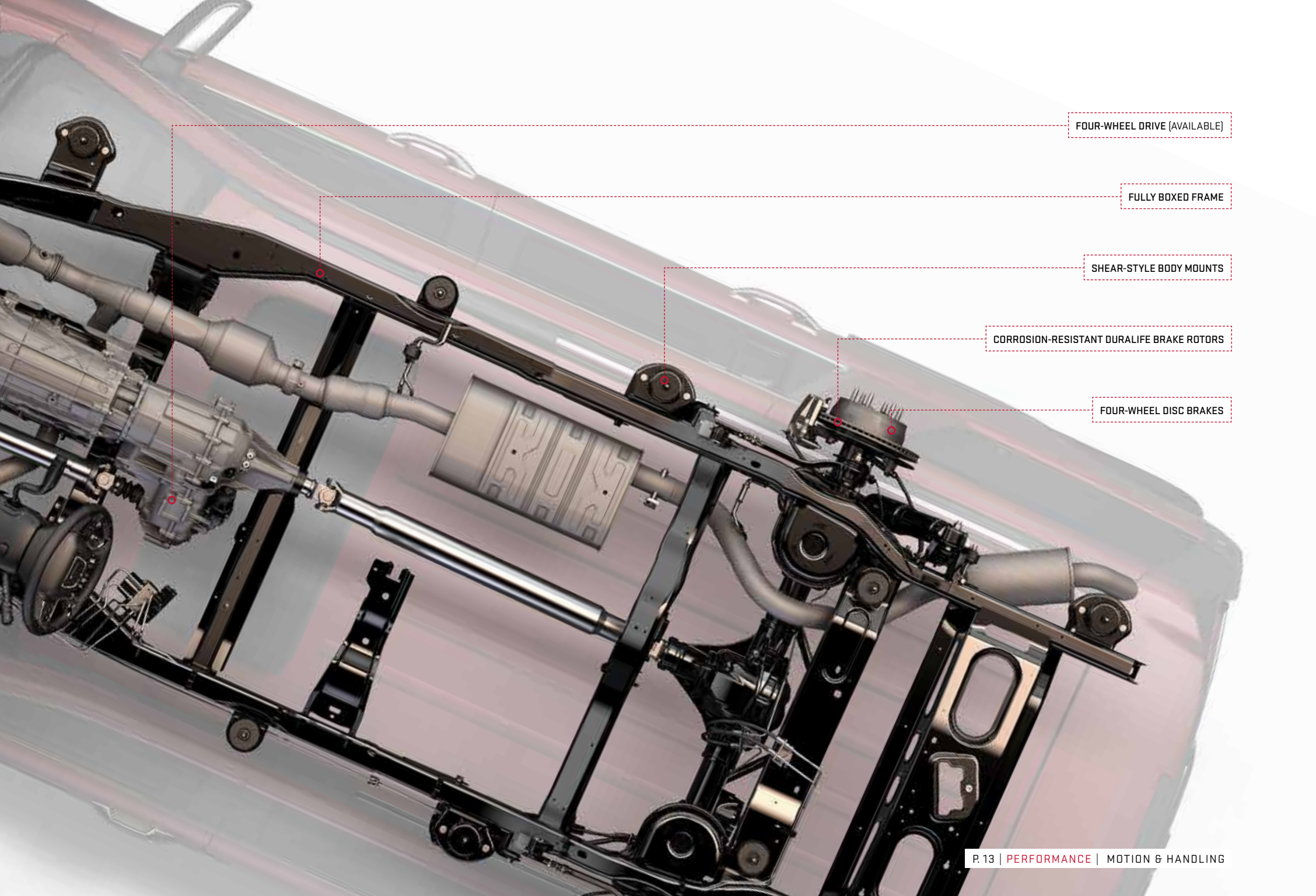

FOUR-WHEEL DRIVE (AVAILABLE)

FULLY BOXED FRAME

SHEAR-STYLE BODY MOUNTS

CORROSION-RESISTANT DURALIFE BRAKE ROTORS

FOUR-WHEEL DISC BRAKES

## SOME HOBBIES REQUIRE BIGGER EQUIPMENT

Everything about Yukon is designed and engineered for ease of travel, including pulling your recreational equipment. Yukon offers a maximum trailer weight rating of up to 3856 kg (8500 lb.).<sup>1</sup>



YUKON SLT IN WHITE FROST TRICOAT  
shown with available equipment.



**AUTOMATIC LOCKING REAR DIFFERENTIAL** This feature directs power to the rear wheel with the most traction on loose gravel or slippery surfaces.

**AUTO GRADE BRAKING** It automatically senses when you want to slow your Yukon and engages a Grade Braking shift pattern within the transmission to help maintain your desired speed.

**PREMIUM SMOOTH-RIDE SUSPENSION WITH AIR LEVELLER** The available system constantly senses and adjusts Yukon's rear suspension height to maintain a level position. It also contributes to Yukon's max trailering rating.

**HILL START ASSIST** Sensors automatically detect when Yukon is on a 5 percent grade or more. It holds the brakes momentarily, preventing rollback under certain conditions. It's most effective when trailering, providing time to switch from the brake to the accelerator without rolling.

**TOW/HAUL MODE** Providing more power to accelerate when trailering or hauling heavy loads, Tow/Haul mode raises transmission upshift points. It also helps reduce speed by using engine compression to slow Yukon instead of merely braking.

**TRAILER SWAY CONTROL** Help keep both you and your Yukon heading in the same direction, automatically. The system uses StabiliTrak sensors to detect a swaying trailer, applying both Yukon's and the trailer's brakes (if properly equipped) to help bring it back in line.

**TRAILER BRAKE CONTROLLER** For fingertip control and easy monitoring of your trailer brakes, there's an available integrated trailer brake controller. Conveniently located to the left of the steering wheel, it displays the level of brake force or "gain" in the Driver Information Centre.

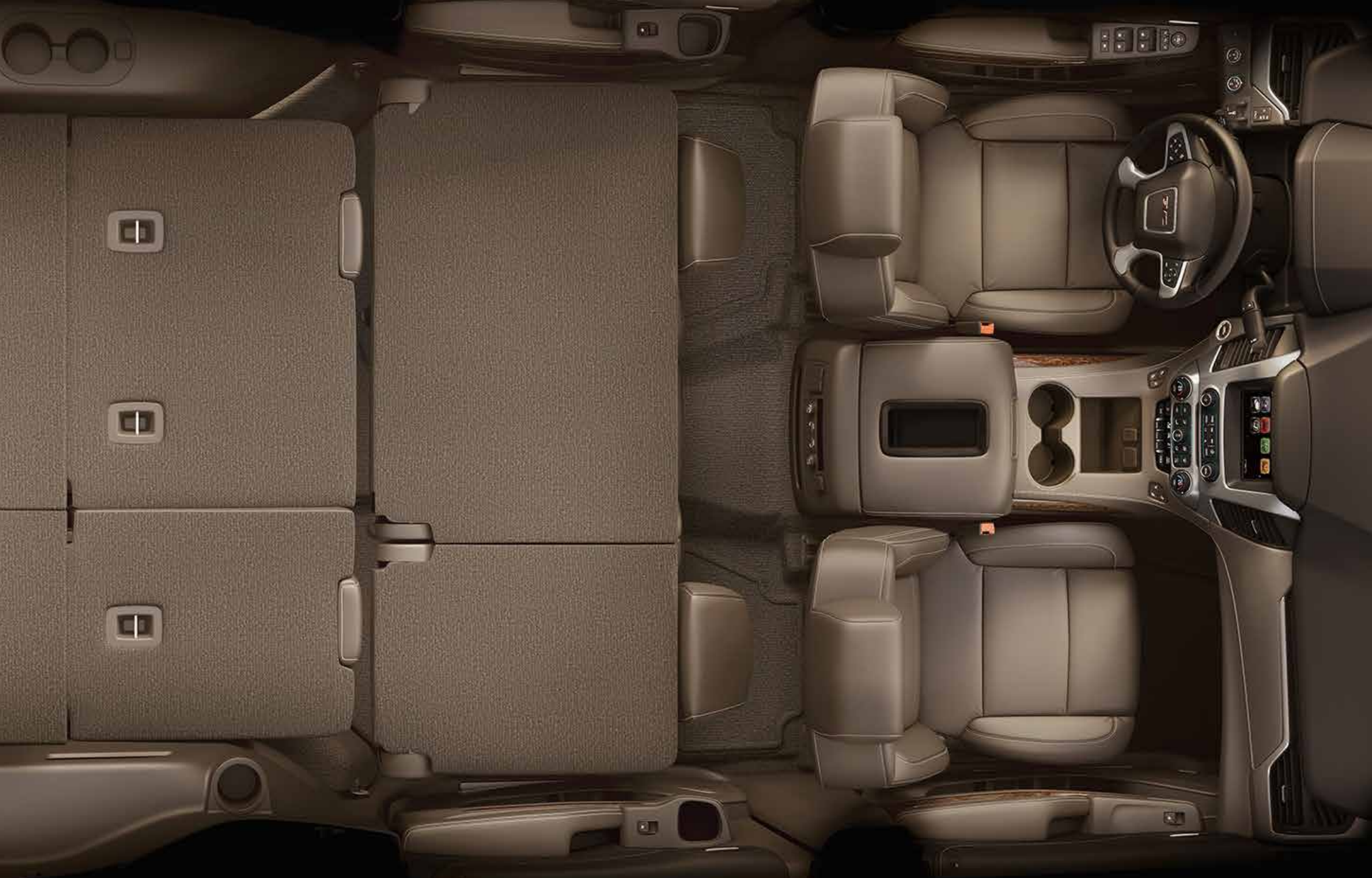

YUKON XL SLT INTERIOR IN COCOA/DUNE  
shown with available equipment.





## YOU ONLY HAVE TWO HANDS

To help you load it up while your hands are full, Yukon Denali and SLT include a hands-free, programmable power liftgate. Once the liftgate is open, Yukon makes it easy to lower the second row with an easy-to-use, power-release fold-and-tumble feature, and the third row lowers with the touch of a button, to create a flat cargo floor. And since we all travel with plenty of things we just can't leave behind, you'll find generous storage compartments, including an expansive centre console as well as power outlets, integrated throughout Yukon.

+ **Three-Prong 110-Volt Outlet Provides a Convenient Charge**

+ **Under-Floor Cargo Management System and Cargo Net Keep Gear Organized and Secure**

+ **Hidden Storage Behind the Centre-Mounted Display; Includes USB<sup>1</sup> Outlet**



<sup>1</sup>Not compatible with all devices.



YUKON DENALI INTERIOR IN JET BLACK  
shown with available equipment.





## IN TOUCH

Yukon offers OnStar® 4G LTE with built-in Wi-Fi® hotspot<sup>1</sup> to keep you connected, informed and entertained—on the go. There's also the 8" diagonal colour touch-screen with GMC Infotainment System<sup>2</sup> that provides seamless hands-free integration of digital devices. Yukon Denali adds an 8" Customizable Driver Display so you can choose the information you see and how you see it. Denali also includes a Bose® Centerpoint® surround sound system and a four-colour Head-Up Display to help keep relevant information in your vision and your eyes focused on the road.

+ 8" Diagonal Customizable Driver Display (Denali)

+ Wireless Charging Mat<sup>3</sup> Keeps You Powered Up (Denali)

+ Bluetooth®<sup>4</sup> Hands-Free Audio Streaming

+ Teen Driver System Helps Encourage Safe Driving Habits



<sup>1</sup>Visit [onstar.ca](http://onstar.ca) for coverage maps, details and system limitations. Service plan required. Available 4G LTE with Wi-Fi hotspot requires WPA2-compatible mobile device and data plan. Data plans provided by AT&T.® Services vary by model, service plan, conditions as well as geographical and technical restrictions. OnStar with 4G LTE connectivity is available on select vehicle models and in select markets. Vehicle must be started or in accessory mode to access Wi-Fi. <sup>2</sup>Full functionality requires compatible Bluetooth and smartphone, and USB connectivity for some devices. Data plan rates apply. <sup>3</sup>The vehicle must be on or Retained Accessory Power must be active. Remove all objects from the charging pad. Place the compatible mobile device face up on the charging symbol on the charging pad. Move the device slowly until the battery charging symbol displays on the touch-screen, indicating the device is charging. See your Infotainment System Owner's Manual. <sup>4</sup>Not compatible with all devices.

## TECHNOLOGY AT YOUR FINGERTIPS, YOUR EYES, YOUR EARS AND YOUR VOICE

The idea behind the design and engineering of Yukon is to help you focus solely on the road. That means offering technologies that allow you to keep your eyes on the road while keeping you connected, informed and entertained at the same time.



**CUSTOMIZABLE DRIVER DISPLAY** Yukon Denali features a reconfigurable gauge cluster with three selectable themes—Standard, Technology and Media. Personalize the 8" diagonal Customizable Driver Display for optimized information placement.

**PHONE INTEGRATION** Yukon offers Apple CarPlay™ and Android Auto™ compatibility.<sup>1</sup> With Apple CarPlay™, the apps you love on your iPhone® come alive through Siri® or the built-in display, while Android Auto easily integrates the power and functionality of your Android™ phone into Yukon. Just plug into the USB<sup>2</sup> outlet and go.



**NAVIGATION**<sup>3</sup> In response to your voice or touch, Yukon's available Navigation System displays 2-D or 3-D map graphics on the 8" diagonal centre-mounted screen. SiriusXM Traffic<sup>4</sup> (3 trial months of SiriusXM<sup>4</sup>) incorporates real-time traffic and road conditions, directing you toward the most efficient route.

**GMC INFOTAINMENT SYSTEM**<sup>5</sup> Yukon features a standard full-colour 8" diagonal screen for easy viewing and hands-free, voice-activated control of your smartphone. Stream music, sync MP3 music, receive vocalized text messages, benefit from Siri® Eyes Free<sup>6</sup> assistance, connect libraries from multiple devices and store phone contacts.







#### **BOSE CENTERPOINT SURROUND SOUND**

For the sensation of a live performance, Denali includes a 10-speaker surround sound system with SurroundStage® signal processing. SLT and SLE feature nine premium speakers and a centre-mounted subwoofer for rich bass tones and an enhanced listening experience.

#### **FOUR-COLOUR HEAD-UP DISPLAY (HUD)**

This standard Denali feature projects essential driving information at eye level so your eyes stay on the road.



#### **REAR-SEAT ENTERTAINMENT SYSTEM**

This available system includes Blu-ray™/DVD player, 9.2" diagonal display, digital headphones and HDMI-hardwired connector as well as the ability to project devices wirelessly. Yukon XL features two screens, one specifically for third-row passengers.

**WIRELESS CHARGING MAT<sup>7</sup>** With wireless charging (only on Denali) conveniently located on the centre console, you can power up your compatible phone or device anytime the vehicle is running.



<sup>1</sup>Vehicle user interfaces are products of Apple® and Google™ and their terms and privacy statements apply. Requires compatible smartphone. Data plan rates apply. <sup>2</sup>Not compatible with all devices. <sup>3</sup>At time of printing, detailed map coverage is available for most major urban areas of the United States and for certain metropolitan areas of Canada (Vancouver, Calgary, Edmonton, Winnipeg, Windsor, London, Toronto, Ottawa, Montreal, Quebec City and Halifax). Coverage is significantly limited outside these areas. <sup>4</sup>SiriusXM satellite radio service and SiriusXM Traffic are sold separately after trial period. SiriusXM Traffic is available in select markets and requires SiriusXM satellite radio service. If you decide to continue service after your trial subscription, the plan you choose will automatically renew and bill at then-current rates until you call 1-888-539-7474 to cancel. Other fees and taxes will apply. All fees and programming subject to change. See complete terms and conditions at [siriusxm.ca/terms](http://siriusxm.ca/terms). <sup>5</sup>Full functionality requires compatible Bluetooth and smartphone, and USB connectivity for some devices. Data plan rates apply. <sup>6</sup>Requires GMC Infotainment System and compatible iPhone® running iOS 6 or newer. <sup>7</sup>The vehicle must be on or Retained Accessory Power must be active. Remove all objects from the charging pad. Place the compatible mobile device face up on the charging symbol on the charging pad. Move the device slowly until the battery charging symbol displays on the touch-screen, indicating the device is charging. See your Infotainment System Owner's Manual.

# PROACTIVE BEATS REACTIVE

Yukon offers a comprehensive array of available driver-alert technologies, engineered with the idea that the best way to handle a collision is to avoid it.

Safety features are no substitute for the driver's responsibility to operate the vehicle in a safe manner. The driver should remain attentive to traffic, surroundings and road conditions at all times. Read the vehicle Owner's Manual for important feature limitations and information.

**FORWARD COLLISION ALERT** The available feature warns you when you're rapidly approaching another vehicle and it detects a collision is imminent. It also provides an alert if you're following a detected vehicle much too closely.

**LOW SPEED FORWARD AUTOMATIC BRAKING<sup>1</sup>** If the vehicle is travelling at a low speed and the available system detects that a front-end collision situation is imminent while following a detected vehicle, and you haven't applied the brakes, the system automatically applies the brakes to help reduce the collision's severity. The system may even help to avoid the collision at very low speeds.

**FRONT PARK ASSIST** This feature alerts you to objects in front of the vehicle while parking.

**ADAPTIVE CRUISE CONTROL<sup>2</sup>** This available feature enhances regular cruise control to allow the vehicle to automatically follow a detected vehicle ahead at the driver-selected following gap while you steer, reducing the need to frequently brake and accelerate.

**LANE KEEP ASSIST WITH LANE DEPARTURE WARNING** This available technology provides gentle steering wheel turns (and Lane Departure Warning alerts if necessary) to help you avoid crashes due to unintentionally drifting out of your lane when you are not actively steering and your turn signal is not activated.

**LANE CHANGE ALERT WITH SIDE BLIND ZONE ALERT<sup>3</sup>** This available innovation provides side-mirror alerts to help you avoid crashing into a moving vehicle detected in your side blind spot (or zone) or a vehicle that is rapidly approaching your side blind spot during a lane-change manoeuvre.

<sup>1</sup>The Forward Automatic Braking feature may help reduce crash damage under certain conditions discussed in the Owner's Manual. Never rely on this feature to brake the vehicle. <sup>2</sup>Adaptive Cruise Control is no substitute for the driver's personal responsibility to operate the vehicle in a safe manner. The driver needs to remain attentive to traffic and road conditions and provide the steering, braking or other inputs necessary to retain control of the vehicle. The Front Automatic Braking feature may help reduce crash damage under certain conditions discussed in the Owner's Manual. Never rely on this feature to brake the vehicle. <sup>3</sup>Before making a lane change, always check the exterior and interior rear-view mirrors, look over your shoulder for vehicles and hazards and start the turn signal.







**SAFETY ALERT SEAT** The available GM-patented Safety Alert Seat provides you with the option of getting haptic seat-bottom vibration pulses instead of audible crash-avoidance alerts.

○ **REAR PARK ASSIST** This feature alerts you to objects behind the vehicle.

○ **REAR CROSS TRAFFIC ALERT** When in Reverse, the available system provides alerts to help you avoid crashing into approaching cross traffic detected from the left or the right (e.g., out of a crowded parking space or driveway with side obstructions).

○ **ENHANCED SECURITY PACKAGE** To help ensure that it remains in your possession, Yukon surrounds itself with this available package that includes glass breakage sensors, vertical movement sensors, interior motion detectors, door and liftgate lock shields and numerous other theft-deterrent technologies to keep potential thieves at bay.

○ **REAR VISION CAMERA** The centre screen serves as a helpful monitor for the rear-vision camera. It helps you see what's behind you when backing up.

## PEACE OF MIND

Pro Grade Protection is standard on every 2018 Yukon. From maintenance to protecting your entire vehicle, you can drive with confidence.

**2-YEAR/48,000 KM LUBE-OIL-FILTER MAINTENANCE<sup>1</sup>**

**3-YEAR/60,000 KM NEW-VEHICLE LIMITED WARRANTY<sup>2</sup>**

**5-YEAR/160,000 KM POWERTRAIN LIMITED WARRANTY<sup>2</sup>**

**5-YEAR/160,000 KM ROADSIDE ASSISTANCE/COURTESY TRANSPORTATION<sup>2</sup>**

<sup>1</sup>Whichever comes first. Limit of four complimentary Lube-Oil-Filter services in total. Fluid top-offs, inspections, tire rotations, wheel alignments and balancing, etc., are not covered. Conditions and limitations apply. See your dealer for details. <sup>2</sup>Whichever comes first. Conditions and limitations apply; see your dealer for details.







## WE'RE AS CLOSE AS THE BLUE BUTTON

Connect to an OnStar<sup>1</sup> Advisor just by pushing the blue OnStar button in your Yukon. Every 2018 Yukon includes the OnStar Basic Plan<sup>2</sup> for 5 years, plus a limited service trial of the Guidance Plan that includes a comprehensive suite of emergency, security, navigation and diagnostic services.

**EMERGENCY: HELP WHEN IT MATTERS MOST.** With Automatic Crash Response,<sup>3</sup> you can be immediately connected to the help you need the moment you need it, even if you can't ask for it. If you're stranded, have a flat tire or need a tow truck, use Roadside Assistance<sup>4</sup> and an OnStar Advisor can locate a nearby service provider and direct them to your exact location.

**SECURITY: IT CAN HELP RECOVER YOUR VEHICLE IF IT'S EVER STOLEN.** Breathe easy knowing a comprehensive suite of Stolen Vehicle Assistance<sup>5</sup> services is available to help potentially recover your vehicle. With Theft Alarm Notification,<sup>6</sup> OnStar can alert you if your vehicle's alarm is sounding, and if your vehicle is stolen, OnStar will work with authorities to help locate and recover it quickly.

**NAVIGATION: TRAVEL MADE EASY.** Turn-by-Turn Navigation<sup>7</sup> makes everywhere you go as familiar as your own neighbourhood. And with OnStar AtYourService,<sup>8</sup> an Advisor can help you book a hotel room on the go.

**CONNECTIONS: FAST AND RELIABLE.** Stay connected almost anywhere, anytime with the built-in Wi-Fi hotspot<sup>1</sup> and connect up to seven devices at fast speed.

**VEHICLE MANAGER: PREPARING YOU FOR WHAT'S AHEAD.** Enjoy the ultimate ownership experience with your myGMC mobile app.<sup>9</sup> Use Remote Access<sup>10</sup> to start your engine, lock and unlock your doors, honk the horn and flash the lights from anywhere there is cellphone service. Get real-time Diagnostic Alerts<sup>11</sup> or a monthly diagnostics report of the vehicle's engine, transmission and more with Advanced Diagnostics.<sup>11</sup>

<sup>1</sup>Visit onstar.ca for coverage maps, details and system limitations. Service plan required. Available 4G LTE with Wi-Fi hotspot requires WPA2-compatible mobile device and data plan. Data plans provided by AT&T. Services vary by model, service plan, conditions as well as geographical and technical restrictions. OnStar with 4G LTE connectivity is available on select vehicle models and in select markets. Vehicle must be started or in accessory mode to access Wi-Fi. <sup>2</sup>The OnStar Basic Plan is available on eligible new vehicles for 5 years and is transferable to subsequent owners for the remaining term. It includes the monthly Diagnostics Report emails (capabilities vary by model), Dealer Maintenance Notification, access to select vehicle mobile app features and more. This plan does not include emergency, security or navigation services. These and other services require a paid or Add-On Plan. Visit onstar.ca for vehicle availability, coverage maps, details and system limitations. Available 4G LTE with Wi-Fi hotspot requires WPA2-compatible mobile device and data plan. Data plans are provided by AT&T or its local service provider. <sup>3</sup>Visit onstar.ca for vehicle availability. Services and connectivity vary by model, conditions as well as geographical and technical restrictions. Requires active OnStar service and data plan. Data plans provided by AT&T or its local service provider. <sup>4</sup>Roadside service provided by Allstate Roadside Services. Limitations and restrictions apply. <sup>5</sup>Services vary by model and conditions. Requires the Security or Guidance Plan, or the Stolen Vehicle Assistance Plan Add-On. <sup>6</sup>Services vary by model and conditions. Visit onstar.ca for vehicle availability. Theft Alarm Notification features vary by vehicle. Requires a factory-installed theft-deterrent system, the Security or Guidance Plan, or the Stolen Vehicle Assistance Plan Add-On, and the selection of notification communication preference(s). Vehicles must be locked electronically to arm the factory-installed theft-deterrent system. Messaging and data rates may apply. <sup>7</sup>Requires ABS and Guidance Plan or Navigation Plan Add-On. Visit onstar.ca for coverage maps. Services vary by model. <sup>8</sup>Hotel booking and billing done through Priceline.<sup>9</sup> Valid offers may vary. Access AtYourService by pressing the blue OnStar button. <sup>10</sup>Available on select Apple® and Android devices. Some features may require a paid OnStar service plan. Features and capability may vary by vehicle, device, conditions as well as geographical and technical restrictions. Device data connection required. <sup>11</sup>Services vary by model, conditions as well as geographical and technical restrictions. Unlock feature requires automatic locks. Remote start requires factory-installed and enabled remote-start system. <sup>12</sup>Capabilities vary by model and service plan. Visit onstar.ca for vehicle availability. Message and data rates may apply. Requires active OnStar service, email address on file and enrolment in Advanced Diagnostics. Not all issues will deliver alerts. On-Demand Diagnostics requires a paid service plan.

### INSTRUMENT PANEL ACCENTS

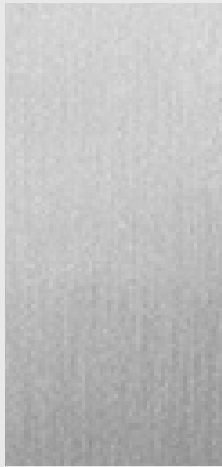

Axiom Aluminum

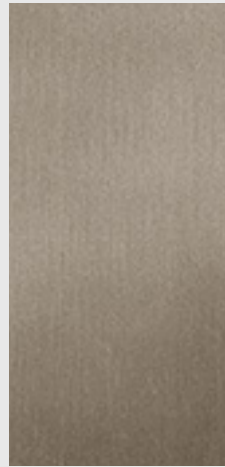

Burnished Aluminum

### DOOR AND CONSOLE ACCENTS



Periwood Wood Tone

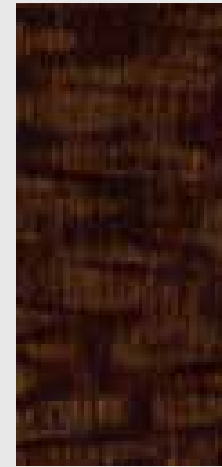

Grand Lace Wood Tone



Mastique Ash Wood

### MODELS

Model	Axiom Aluminum	Burnished Aluminum	Periwood Wood Tone	Grand Lace Wood Tone	Mastique Ash Wood
SLE	●	—	● <sup>1</sup>	● <sup>2</sup>	—
SLT	●	—	● <sup>1</sup>	● <sup>2</sup>	—
DENALI	—	●	—	—	●

KEY ● STANDARD ○ AVAILABLE — NOT AVAILABLE <sup>1</sup>Included with Cocoa/Dune interior trim. <sup>2</sup>Included with Jet Black interior trim.

### EXTERIOR COLOURS See your GMC dealer for more exterior colour details and availability.

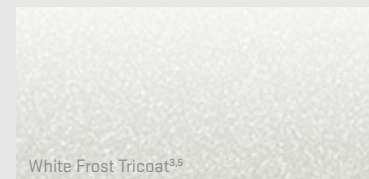
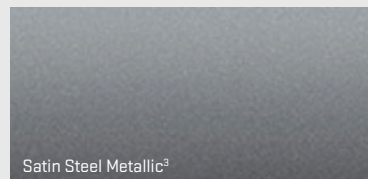
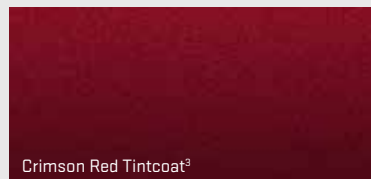
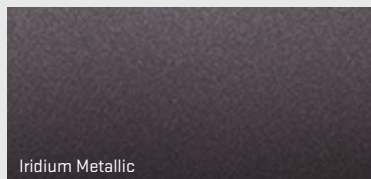
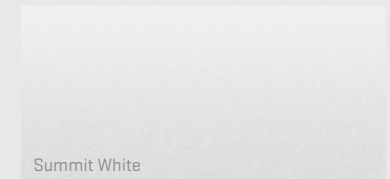
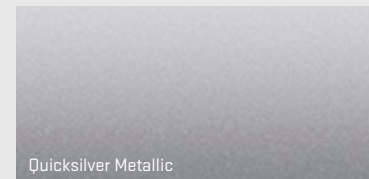
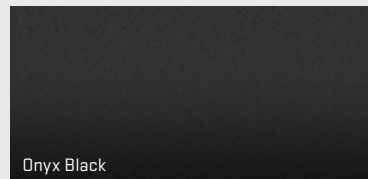
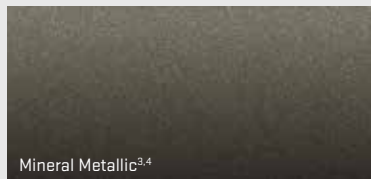

<sup>3</sup>Additional charge, premium paint. <sup>4</sup>Denali models only. <sup>5</sup>Not available on SLE trim.



## INTERIOR COLOURS/SEATING SURFACES CLOTH



Cocoa/Dune

Jet Black/Jet Black



## LEATHER APPOINTMENTS



Cocoa/Dune Perforated

Jet Black/Jet Black Perforated

Cocoa/Shale Perforated With Unique Denali Accents

Cocoa/Dark Atmosphere Perforated With Unique Denali Accents

Jet Black/Jet Black Perforated With Unique Denali Accents



## WHEELS



18" Bright Machined Aluminum [UHN]  
Standard on SLE and SLT



20" Polished Aluminum [RD5]  
Available on SLE and SLT



20" Ultra-Bright Machined Aluminum [NZ6]  
Standard on Denali



20" Chrome Aluminum [RTL]  
Available on Denali



22" Ultra-Bright Aluminum with Midnight Silver Premium Paint [SII]  
Available on Denali



22" 6-Spoke Chrome [RPT]  
Available on SLE, SLT and Denali



22" 6-Spoke Chrome [SMI]  
Available on SLE, SLT and Denali



22" 6-Spoke Split Chrome [SEU]  
Standard on SLT Premium Edition

## ACCESSORIES

GMC Accessories are designed so you can personalize your Yukon to fit your style as well as your needs. They're also engineered and tested to meet Professional Grade standards.

- ROOF RACK CROSS RAIL PACKAGE
- CHROME GRILLE
- CHROME MIRROR COVERS
- 22" WHEELS
- CHROME DOOR HANDLES
- CHROME ASSIST STEPS
- DUAL-SCREEN REAR-SEAT ENTERTAINMENT SYSTEM



## YUKON SPECIFICATIONS

### MECHANICAL

	SLE	SLT	DENALI
<b>ACTIVE AERO GRILLE SHUTTERS</b>	●	●	●
<b>ALTERNATOR</b> 150-amp	●	●	–
170-amp	–	–	●
<b>BATTERY</b> Heavy-duty maintenance-free with rundown protection	●	●	●
<b>BRAKES</b> 4-wheel Anti-lock Brake System (ABS), 4-wheel disc with Duralife rotors	●	●	●
<b>DRIVETRAIN</b> 4x2	●	●	–
4x4. Single-speed active transfer case.	○	○	–
4x4. Active 2-speed transfer case with rotary controls. On SLE and SLT trims, included and only available with Heavy-Duty Trailing Package.	○	○	●
<b>ENGINES</b> 5.3L V8 EcoTec3 with aluminum block. Includes Active Fuel Management, Direct Injection and continuously Variable Valve Timing.	●	●	–
6.2L V8 EcoTec3 with aluminum block. Includes Active Fuel Management, Direct Injection and continuously Variable Valve Timing.	–	–	●
<b>ENGINE BLOCK HEATER</b>	○	○	○
<b>EXTERNAL ENGINE OIL COOLER</b> Heavy-duty air-to-oil, integral to radiator	●	●	●
<b>HEAVY-DUTY AUTOMATIC LOCKING REAR DIFFERENTIAL</b>	●	●	●
<b>INTEGRATED TRAILER BRAKE CONTROLLER</b> On SLE and SLT trims, included and only available with Heavy-Duty Trailing Package	○	○	●
<b>STABILITRAK</b> Stability control system and traction control. Includes Trailer Sway Control and Hill Start Assist.	●	●	●
<b>STEERING</b> Electric, power	●	●	●
<b>SUSPENSION</b> Front independent coil-over-shock with stabilizer bar	●	●	●
Rear multilink with coil springs	●	●	●
Premium Smooth Ride Suspension	●	●	–
Automatic Rear Level Control, air. On SLE and SLT trims, included and only available with Heavy-Duty Trailing Package.	○	○	–
Magnetic Ride Control. Includes automatic air-level control.	–	–	●
<b>TRAILERING EQUIPMENT</b> Includes hitch platform with 2" trailering receiver and 7-wire harness with independent fused trailering circuits mated to a 7-way sealed connector.	●	●	●
<b>TRANSMISSION</b> 6-speed automatic, electronically controlled with overdrive, Tow/Haul mode, Electronic Engine Grade Braking and tap-up/tap-down shifting	●	●	–
10-speed automatic, electronically controlled with overdrive, Tow/Haul mode, Electronic Engine Grade Braking and tap-up/tap-down shifting	–	–	●

### SEATING

<b>SEATS</b> Front buckets with Premium Cloth. Includes 10-way power driver seat, 6-way power cushion, 2-way power lumbar control and power recline. Front-passenger seat is 6-way power.	●	–	–
Front 40/20/40 split bench with Premium Cloth. Includes 10-way power driver-seat adjuster, 6-way power passenger-seat adjuster, centre fold-down armrest with storage, lockable storage compartments in seat cushion (includes auxiliary power outlet), adjustable outboard head restraints and storage pockets.	○	–	–
Front heated and ventilated perforated leather-appointed seating. Includes full-feature reclining buckets with 12-way power driver and front-passenger seat adjuster, including 6-way power cushion, 2-way power recline and 4-way power lumbar for driver and front passenger. Includes driver memory feature (no memory on lumbar).	–	●	●
Heated second-row seats. Outboard positions.	–	●	●
Second-row 60/40 split-folding bench with manual operation	●	–	–
Second-row 60/40 split-folding bench with power release	–	●	○
Second-row buckets with power release	–	○	●
Third-row 60/40 manual split-folding bench	●	–	–
Third-row 60/40 split bench with power-folding seatback	–	●	●

### INSTRUMENTATION AND CONTROLS

	SLE	SLT	DENALI
<b>ADAPTIVE CRUISE CONTROL</b> <sup>1</sup> With Forward Automatic Braking <sup>2</sup> to maintain a preset following distance	–	○	○
<b>FRONT AND REAR PARK ASSIST</b>	●	●	●
<b>HEAD-UP DISPLAY</b> Includes digital multifunction readouts	–	–	●
<b>INSTRUMENTATION</b> 4.2" diagonal multicolour Driver Information Centre. Includes speedometer, odometer/trip odometer, fuel level, voltmeter, engine temperature, oil pressure and tachometer.	●	●	–
8" diagonal Customizable Driver Display	–	–	●
<b>POWER-ADJUSTABLE PEDALS</b> On SLE trim, included and only available with Convenience Package or SLE Value Package	○	●	●
<b>PUSH-BUTTON KEYLESS START</b>	–	●	●
<b>STEERING WHEEL</b> Leather-wrapped, with controls for audio, Driver Information Centre, cruise control and Bluetooth®-enabled phone	●	●	●
Heated steering wheel	–	●	●
Tilt-adjustable steering column with brake/transmission shift interlock	●	–	–
Power-tilt and -telescopic steering column	–	●	●
<b>TEEN DRIVER</b> A configurable feature that lets you activate customizable vehicle settings associated with a key fob, to help encourage safe driving behaviour. It can limit certain vehicle features, and it prevents certain safety systems from being turned off. An in-vehicle report card gives you information on your teen's driving habits and helps you to continue to coach your new driver.	●	●	●
<b>TOW/HAUL MODE SELECTOR</b>	●	●	●
<b>TIRE PRESSURE MONITORING SYSTEM</b> Includes Tire Fill Alert. Does not monitor spare tire.	●	●	●

### INTERIOR DETAILS

<b>ACTIVE NOISE CANCELLATION</b>	–	–	●
<b>CARPET</b> Colour-keyed with removable carpeted floor mats for first and second rows	●	●	●
<b>CLIMATE CONTROL</b> Tri-zone automatic air conditioning. Includes individual climate settings for driver, front passenger and rear passengers.	●	●	●
Defogger, rear-window electric	●	●	●
<b>CONSOLE</b> Floor with storage area and cupholders. Included and only available with front bucket seats.	●	●	●
<b>CUPHOLDERS</b> Front seating area, rear floor console, third-row outboard side trim	●	●	●
<b>MIRROR</b> Interior rear-view with manual day/night	●	–	–
Auto-dimming rear-view. On SLE trim, included and only available with Convenience Package or SLE Value Package.	○	●	●
<b>OUTLETS</b> 12-volt power, 5 (4 with front bench seat)	●	●	●
3-prong household style 110-volt, 1.1-amp, 150-watt	●	●	●
<b>PASSIVE ENTRY SYSTEM</b> Includes remote keyless entry	–	●	●
<b>POWER PROGRAMMABLE DOOR LOCKS</b> Includes lockout protection	●	●	●
<b>POWER WINDOWS</b> With all express-down and front express-up	●	●	●
<b>REMOTE VEHICLE STARTER SYSTEM</b> With keyless entry	●	●	●
<b>SUNROOF</b> Power, tilt-sliding with express-open and -close and wind deflector	–	○	○
<b>UNIVERSAL HOME REMOTE</b> Includes programmable garage-door opener. On SLE trim, included and only available with Convenience Package or SLE Value Package.	○	●	●
<b>WIRELESS CHARGING MAT</b> <sup>3</sup> Centre console-mounted. Not compatible with all phones.	–	–	●



SLE    SLT    DENALI

---

## ENTERTAINMENT/COMMUNICATION/NAVIGATION

<b>8" DIAGONAL COLOUR TOUCH-SCREEN WITH GMC INFOTAINMENT SYSTEM<sup>4</sup></b> Includes AM/FM/SiriusXM <sup>5</sup> 3-month trial with up to 5 USB <sup>6</sup> ports and auxiliary jack. Includes text-message alerts, Siri <sup>®</sup> Eyes Free <sup>7</sup> functionality through voice command, Bluetooth <sup>8</sup> streaming audio for music and most phones, hands-free smartphone integration, voice-activated technology for radio and phone and an articulating screen with hidden storage.	●	●	-
<b>8" DIAGONAL COLOUR TOUCH-SCREEN NAVIGATION<sup>9</sup> WITH GMC INFOTAINMENT SYSTEM<sup>4</sup></b> Includes AM/FM/SiriusXM <sup>5</sup> 3-month trial with up to 5 USB <sup>6</sup> ports and auxiliary jack. Includes text-message alerts, Siri <sup>®</sup> Eyes Free <sup>7</sup> functionality through voice command, Bluetooth <sup>8</sup> streaming audio for music and most phones, hands-free smartphone integration, voice-activated technology for radio and phone and an articulating screen with hidden storage. On SLT, included with Sun, Sound and Destination Package.	-	○	●
HD Radio	●	●	●
Single-slot CD/MP3 player	●	●	●
Bose <sup>®</sup> premium 9-speaker sound system with subwoofer in centre console	●	●	-
Bose Centerpoint <sup>®</sup> surround sound premium 10-speaker sound system	-	-	●
<b>REAR-SEAT ENTERTAINMENT SYSTEM</b> Includes Blu-ray™/DVD player, overhead 9.2" diagonal screen, Wi-Fi <sup>®</sup> wireless projection capability with select devices, Video Voice Over, remote control, 2 2-channel wireless digital headphones (4 headphones on XL), rear-seat audio controls, auxiliary HDMI/MHL audio/video input and 2 USB <sup>6</sup> ports. Replaces single-slot CD/MP3 player.	-	○	○
9.2" diagonal screen, third row. Included and only available with Rear-Seat Entertainment System on XL models.	-	○	○
<b>ONSTAR</b> Basic Plan <sup>9</sup> for 5 years	●	●	●
OnStar Guidance Plan 6-month trial period, including a 3 GB or 3-month data plan trial, whichever comes first	●	●	●
OnStar 4G LTE with built-in Wi-Fi hotspot <sup>10</sup>	●	●	●
<b>SIRIUSXM<sup>5</sup></b> Includes 3 trial months of service	●	●	●

## OPTION PACKAGES

<b>DENALI ULTIMATE PACKAGE</b> Includes Sun, Sound and Destination Package contents, Enhanced Security Package contents, power-retractable assist steps, Adaptive Cruise Control <sup>1</sup> with Forward Automatic Braking <sup>2</sup> and 22" ultra-bright machined aluminum wheels with Midnight Silver premium paint. Deletes single-slot CD/MP3 player when ordered.	-	-	○
<b>SLT PREMIUM EDITION</b> Includes 22" 6-spoke split chrome accessory wheels, bright bodyside mouldings, accessory chrome grille insert and polished exhaust tip	-	○	-
<b>SLE VALUE PACKAGE</b> Includes interior rear-view auto-dimming mirror, power-adjustable pedals, power liftgate, Universal Home Remote and 20" polished aluminum wheels	○	-	-
<b>HEAVY-DUTY TRAILERING PACKAGE</b> Includes 3.42 rear axle ratio, trailer brake controller, increased-capacity suspension with rear air level control and 2-speed AutoTrac transfer case on 4x4 models	○	○	-
<b>CONVENIENCE PACKAGE</b> Includes interior auto-dimming rear-view mirror, power-adjustable pedals, power liftgate and Universal Home Remote	○	-	-
<b>ENHANCED DRIVER ALERT PACKAGE</b> Includes Forward Collision Alert, Lane Keep Assist with Lane Departure Warning, Safety Alert Seat, IntelliBeam headlamps and Low Speed Forward Automatic Braking. When Adaptive Cruise Control <sup>1</sup> is ordered on SLT and Denali, Low Speed Forward Automatic Braking is replaced with Forward Automatic Braking. <sup>2</sup>	○	●	●
<b>ENHANCED SECURITY PACKAGE</b> Includes body security content, theft-deterrent system, self-powered horn, interior movement and vehicle inclination sensors, door and liftgate lock shields and glass breakage sensors in rear quarter glass and liftgate window. Removes sunglass holder and conversation mirror from overhead console.	-	○	○
<b>SUN, SOUND AND DESTINATION PACKAGE</b> Includes power sunroof, Rear-Seat Entertainment System and audio system with Navigation <sup>9</sup> on SLT trim	-	○	○
<b>MEMORY PACKAGE</b> Includes memory for driver seat, steering column, exterior rear-view mirrors and pedals	-	●	●

## EXTERIOR STYLING AND FUNCTIONALITY

<b>ASSIST STEPS</b> Black with chrome inserts	●	●	●
Power-retractable with bright accent strip and LED perimeter lighting	-	-	○
<b>GLASS</b> Solar-Ray deep-tinted. All windows except light-tinted glass on windshield and driver- and front-passenger-side glass.	●	●	●
<b>LIGHTS</b> Halogen projector-beam headlamps with automatic exterior lamp control, LED signature lighting and flash-to-pass	●	●	-
HID projector-beam headlamps with automatic exterior lamp control, LED signature lighting and flash-to-pass	-	-	●
Halogen fog lamps	●	●	●
IntelliBeam, automatic high-beam on/off. On SLE trim, included and only available with Enhanced Driver Alert Package.	○	●	●

KEY    ● STANDARD    ○ AVAILABLE    - NOT AVAILABLE

SLE    SLT    DENALI

---

<b>LUGGAGE RACK</b> Roof-mounted side rails, black; black with bright accent on Denali trim	●	●	●
<b>MOULDINGS</b> Bodyside, body-colour	○	○	-
Bodyside, includes bright inserts	●	○	●
<b>MIRRORS</b> Heated, power-adjustable, manual-folding, body-colour. Includes driver-side spotter mirror.	●	-	-
Heated power-folding, power-adjustable, driver-side auto-dimming, body-colour mirrors with integrated turn-signal indicators, ground illumination and curb-tilt	-	●	●
<b>PROGRAMMABLE POWER LIFTGATE</b> On SLE trim, included and only available with Convenience Package or SLE Value Package	○	-	-
Hands-free liftgate capability	-	●	●
<b>WIPERS</b> Front rain-sensing intermittent wet-arm with flat blade and pulse washers	●	●	●
Rear intermittent with washer	●	●	●

## SAFETY AND SECURITY

<b>AIRBAGS<sup>11</sup></b> Dual-stage frontal with Passenger Sensing System	●	●	●
Front centre airbag: <sup>11</sup> Not included with available front 40/20/40 split bench on SLE.	●	●	●
Front and rear head-curtain airbags <sup>11</sup> for all outboard seating positions with rollover sensor	●	●	●
Front-seat-mounted side-impact driver and front-passenger airbags <sup>11</sup> for thorax and pelvis protection	●	●	●
<b>FORWARD COLLISION ALERT</b> On SLE trim, included and only available with Enhanced Driver Alert Package	○	●	●
<b>LANE KEEP ASSIST WITH LANE DEPARTURE WARNING</b> On SLE trim, included and only available with Enhanced Driver Alert Package	○	●	●
<b>LOW SPEED FORWARD AUTOMATIC BRAKING</b> On SLE trim, included and only available with Enhanced Driver Alert Package	○	●	●
<b>FORWARD AUTOMATIC BRAKING<sup>2</sup></b> Included and only available with Adaptive Cruise Control <sup>1</sup>	-	○	○
<b>REAR CROSS TRAFFIC ALERT</b>	-	●	●
<b>REAR VIEW CAMERA</b>	-	●	●
<b>SAFETY ALERT SEAT</b> On SLE trim, included and only available with Enhanced Driver Alert Package	○	●	●
<b>LANE CHANGE ALERT WITH SIDE BLIND ZONE ALERT<sup>12</sup></b>	-	●	●
<b>VEHICLE THEFT-DETERRENT SYSTEM</b> Electrical unauthorized entry	●	●	●

<sup>1</sup>Adaptive Cruise Control is no substitute for the driver's personal responsibility to operate the vehicle in a safe manner. The driver needs to remain attentive to traffic and road conditions and provide the steering, braking or other inputs necessary to retain control of the vehicle. The Forward Automatic Braking feature may help reduce crash damage under certain conditions discussed in the Owner's Manual. Never rely on this feature to brake the vehicle. <sup>2</sup>The Forward Automatic Braking feature may help reduce crash damage under certain conditions discussed in the Owner's Manual. Never rely on this feature to brake the vehicle. <sup>3</sup>The vehicle must be on or Retained Accessory Power must be active. Remove all objects from the charging pad. Place the compatible mobile device face up on the charging symbol on the charging pad. Move the device slowly until the battery charging symbol displays on the touch-screen, indicating the device is charging. See your Infotainment System Owner's Manual. <sup>4</sup>Full functionality requires compatible Bluetooth and smartphone, and USB connectivity for some devices. Data plan rates apply. <sup>5</sup>Available in 10 Canadian provinces, three territories and the 48 contiguous United States. Subscription sold separately after trial period. If you decide to continue your service at the end of your trial subscription, the plan you choose will automatically renew and bill at then-current rates until you call 1-888-539-7474 to cancel. Other fees and taxes will apply. All fees and programming subject to change. See SiriusXM "Terms & Conditions" and complete details at siriusxm.ca/terms. <sup>6</sup>Not compatible with all devices. <sup>7</sup>Requires GMC Infotainment System and compatible iPhone<sup>®</sup> running iOS 6 or newer. <sup>8</sup>At time of printing, detailed map coverage is available for most major urban areas of the United States and for certain metropolitan areas of Canada (Vancouver, Calgary, Edmonton, Winnipeg, Windsor, London, Toronto, Ottawa, Montreal, Quebec City and Halifax). Coverage is significantly limited outside these areas. <sup>9</sup>The OnStar Basic Plan is available on eligible new vehicles for 5 years and is transferable to subsequent owners for the remaining term. It includes the monthly Diagnostics Report emails (capabilities vary by model), Dealer Maintenance Notification, access to select vehicle mobile app features and more. This plan does not include emergency, security or navigation services. These and other services require a paid or Add-On Plan. Visit onstar.ca for vehicle availability, coverage maps, details and system limitations. Available 4G LTE with Wi-Fi hotspot requires WPA2-compatible mobile device and data plan. Data plans are provided by AT&T<sup>®</sup> or its local service provider. <sup>10</sup>Visit onstar.ca for coverage maps, details and system limitations. Service plan required. Available 4G LTE with Wi-Fi hotspot requires WPA2-compatible mobile device and data plan. Data plans provided by AT&T. Services vary by model, service plan, conditions as well as geographical and technical restrictions. OnStar with 4G LTE connectivity is available on select vehicle models and in select markets. Vehicle must be started or in accessory mode to access Wi-Fi. <sup>11</sup>Always use safety belts and the correct restraint for your child's age and size. Even in vehicles equipped with the Passenger Sensing System, children are safer when properly secured in a rear seat in the appropriate infant, child or booster seat. Never place a rear-facing infant restraint in the front seat of any vehicle equipped with a passenger airbag. See the Owner's Manual and child safety seat instructions for more safety information. <sup>12</sup>Before making a lane change, always check the exterior and interior rear-view mirrors, look over your shoulder for vehicles and hazards and start the turn signal.

### YUKON/YUKON XL/YUKON DENALI/YUKON XL DENALI ENGINE SPECIFICATIONS

	L83	L86
<b>ENGINE</b>	EcoTec3 5.3L V8 DI, VVT, Active Fuel Management	EcoTec3 6.2L V8 DI, VVT, Active Fuel Management
<b>HP @ RPM</b>	355 @ 5600	420 @ 5600
<b>LB.-FT. TORQUE @ RPM</b>	383 @ 4100	460 @ 4100
<b>ACTIVE FUEL MANAGEMENT</b>	Included	Included
<b>ESTIMATED FUEL-CONSUMPTION RATING<sup>1</sup></b> city/hwy, L/100 km (mpg)		
SHORT WHEELBASE		
4x2	15.1/10.4 (19/27)	—
4x4	15.2/10.8 (19/26)	16.4/10.7 (17/26)
LONG WHEELBASE		
4x2	15.1/10.4 (19/27)	—
4x4	15.3/10.9 (18/26)	17.1/11.3 (17/25)
<b>STANDARD</b>	YUKON YUKON XL	YUKON DENALI YUKON XL DENALI

### YUKON/YUKON XL/YUKON DENALI/YUKON XL DENALI TRANSMISSION SPECIFICATIONS

MODEL	DRIVETRAIN/TRANSMISSION
SLE/SLT	4x2 or 4x4/6-speed electronically controlled automatic with Driver Shift Control, Electronic Engine Grade Braking and Tow/Haul mode
Denali	4x4/10-speed electronically controlled automatic with Driver Shift Control, Electronic Engine Grade Braking and Tow/Haul mode

### MEASUREMENTS/CAPACITIES

	4x2/4x4 YUKON	4x2/4x4 YUKON XL	4x4 YUKON DENALI	4x4 YUKON XL DENALI
<b>WHEELBASE</b> mm (in.)	2946 (116.0)	3302 (130.0)	2946 (116.0)	3302 (130.0)
<b>MAXIMUM CARGO VOLUME<sup>2</sup></b> litres (cu. ft.) Behind first/second/third row	2682/1464/433 (94.7/51.7/15.3)	3447/2172/1113 (121.7/76.7/39.3)	2682/1464/433 (94.7/51.7/15.3)	3447/2172/1113 (121.7/76.7/39.3)
<b>OVERALL LENGTH</b> mm (in.)	5179 (203.9)	5700 (224.4)	5179 (203.9)	5700 (224.4)
<b>OVERALL WIDTH</b> mm (in.)	2045 (80.5)	2045 (80.5)	2045 (80.5)	2045 (80.5)
<b>HEIGHT</b> mm (in.)	1890 (74.4)	1890 (74.4)	1890 (74.4)	1890 (74.4)
<b>FUEL TANK CAPACITY</b> approx. litres (imp. gal.)	98 (21.6)	117 (25.7)	98 (21.6)	117 (25.7)

### MAXIMUM TRAILER WEIGHT RATINGS<sup>3</sup>

MODEL	YUKON EcoTec3 5.3L		YUKON XL EcoTec3 5.3L		YUKON DENALI/YUKON XL DENALI EcoTec3 6.2L	
	AXLE RATIO	MAX. TRAILER WEIGHT, KG (LB.)	AXLE RATIO	MAX. TRAILER WEIGHT, KG (LB.)	AXLE RATIO	MAX. TRAILER WEIGHT, KG (LB.)
<b>YUKON 4x2</b>	3.08/3.42	2948/3856 (6500/8500)	3.08/3.42	2858/3765 (6300/8300)	—	—
<b>YUKON 4x4</b>	3.08/3.42	2858/3720 (6300/8200)	3.08/3.42	2722/3629 (6000/8000)	—	—
<b>DENALI 4x4</b>	—	—	—	—	3.23	3674/3538 (8100/7800)

<sup>1</sup>Fuel-consumption estimates based on GM preliminary testing in accordance with Government of Canada approved test methods. Refer to vehicles.nrcan.gc.ca for details. Your actual fuel consumption may vary. <sup>2</sup>Cargo and load capacity limited by weight and distribution.

<sup>3</sup>Before you buy a vehicle or use it for trailering, carefully review the trailering section of the Owner's Manual. The weight of passengers, cargo and options or accessories may reduce the amount you can tow.



## IMPORTANT WORDS

### PEACE OF MIND, STANDARD WITH EVERY GMC MODEL

When you build them with quality, you can back them with confidence. That's why General Motors of Canada backs every GMC model with the best coverage in Canada. Program highlights include:

- 2-year/48,000 km Lube-Oil-Filter Maintenance<sup>1</sup>
- 3-year/60,000 km New-Vehicle Limited Warranty<sup>2</sup>
- 5-year/160,000 km Powertrain Limited Warranty, with \$0 deductible on repairs and the warranty is fully transferable at no charge<sup>2</sup>
- 5-year/160,000 km Courtesy Transportation<sup>2</sup>
- 5-year/160,000 km 24/7 Roadside Assistance<sup>2</sup>
- 6-year/160,000 km rust-through perforation coverage<sup>2</sup>
- 8-year/130,000 km coverage on catalytic converters and Powertrain Control Modules (PCMs)<sup>2</sup>

### OTHER OWNERSHIP PRIVILEGES AND PROGRAMS:<sup>3</sup>

- **GM Protection Plan (GMPP)**—The only extended service plan backed by the resources and commitment of General Motors, GMPP may be purchased at the time of sale or subsequently during the New-Vehicle Limited Warranty period.
- **Certified Service**—With GM-certified technicians and GM-approved parts, nobody knows your GM vehicle better.
- **GMC Owner Centre**—As an owner, take advantage of the GMC Owner Centre. This online owner's destination gives you access to contests, current offers and helpful resources such as Owner's Manuals. Find out more at [gmcowner.ca](http://gmcowner.ca).

### TO HELP YOU PURCHASE OR LEASE A NEW VEHICLE:

- **Purchase Financing and Leasing**—On-the-spot financing, see dealer for full details.<sup>4</sup>
- **GM Student Bonus Program**—Students or recent graduates of high school, college or university<sup>3</sup> may be eligible to receive a Student Bonus vehicle redemption allowance of \$500 or \$750<sup>5</sup> (tax inclusive) (purchased vehicle dependant) to use toward the purchase, lease or finance of one eligible new GMC vehicle.
- **GM Card**—Cardholders may redeem Earnings toward the total purchase price or lease down payment of an eligible new GMC truck or SUV. Restrictions and limitations apply.<sup>5</sup> For full program details, visit [gmccard.ca](http://gmccard.ca).

### INFORMATION RESOURCES:

You can find more information about these programs from your GMC dealer, or at these information centres:

- The GM website at [gmccanada.ca](http://gmccanada.ca)
- The GM Customer Care Centre at 1-800-GM-DRIVE (1-800-463-7483 or 1-800-263-3830 for TDD users)

### A WORD ABOUT THIS BROCHURE

Some of the equipment shown or described throughout this brochure may be available at extra cost. We have tried to make this brochure comprehensive and factual. We reserve the right, however, to make changes at any time, without notice, in prices, colours, materials, equipment, specifications, models and availability. Specifications, dimensions, measurements, ratings and other numbers in this brochure and other printed materials provided at the dealership or affixed to vehicles are approximates based upon design and engineering drawings and prototypes and laboratory tests. Your vehicle may differ due to variations in manufacture and equipment. Since some information may have been adapted since the time of printing, please check with your GMC dealer for complete details. General Motors of Canada Company reserves the right to lengthen or shorten the model year for any product, for any reason, or to start and end model years at different times.

### A WORD ABOUT ASSEMBLY

GMC vehicles are equipped with engines and components produced and assembled by different operating units of General Motors, its subsidiaries and suppliers to GM worldwide. We sometimes find it necessary to produce GMC vehicles with different or differently sourced components than originally scheduled. Since some options may be unavailable when your vehicle is assembled, we suggest that you verify that your vehicle includes the equipment you ordered or, if there are changes, that they are acceptable to you.

### TRADEMARKS

©2017 General Motors of Canada Company. All rights reserved. The marks appearing in this brochure, including but not limited to: General Motors, GM, GMC, Yukon and their respective logos, emblems, slogans and vehicle model names and body designs; and other marks such as StabiliTrak are trademarks of General Motors and/or General Motors of Canada Company, its subsidiaries, affiliates or licensors. OnStar and the OnStar emblem are registered trademarks of OnStar, LLC. SiriusXM, the SiriusXM logo, channel names and logos are trademarks of SiriusXM Radio, Inc. and are used under licence. Bluetooth is a registered trademark of Bluetooth SIG, Inc. Bose is a registered trademark of the Bose Corporation. Apple, Siri and iPhone are trademarks of Apple, Inc., registered in the U.S. and other countries. Apple CarPlay is a trademark of Apple, Inc. Android and Android Auto are trademarks of Google Inc.

<sup>1</sup>Whichever comes first. Limit of four complimentary Lube-Oil-Filter services in total. Fluid top-offs, inspections, tire rotations, wheel alignments and balancing, etc., are not covered. Conditions and limitations apply. See your dealer for details. <sup>2</sup>Whichever comes first. Conditions and limitations apply; see your dealer for details. <sup>3</sup>Conditions and limitations apply. <sup>4</sup>Subject to eligibility. <sup>5</sup>Program subject to change.

