

# LEAK DETECTORS • ALARMS

LP GAS

K

In Section K:	Alarms & Leak Detectors	LP Tanks & Accessories	Valves & Fittings	Regulators	Pigtails & Hoses
---------------	-------------------------	------------------------	-------------------	------------	------------------

## OP PRODUCTS DETECT-A-LEAK

Detects leaks in anything that can be tested with air or gas pressure. Just daub on and look for bubbles.

Lined cap and stainless steel applicator prevent rust and sediment build-up. Instantly finds gas and air pressure leaks with a non-corrosive formula and the included 4" dauber.

*Gas Leak Detector Fluid:*

**50270** 8-oz. Bottle #02126 12

**50271** 1-Gallon Bottle #02136 4



Instantly finds gas and air pressure leaks with a non-corrosive formula.

**56875** 2-oz. Spray #02176 24



56870



57461

57462



## SAFE-T-ALERT 30 SERIES CLASSIC LP GAS DETECTORS

Features include: Intecheck Circuit eliminates false alarms caused from momentary exposure to LP Gas, aerosol cleaners, hair spray and other flammable gases. Long life, self cleaning sensor. Micro circuit technology saves precious battery power. 46 milliamp (.046 amp.) current draw. • Meets RV standard ANSI A119.2 as required by the RVIA. Loud 85dB alarm alerts you to the presence of LP Gas and Natural Gas. • Test/Reset button can be used to temporarily silence alarm during ventilation. Tests all detector functions with one touch. No dangerous gas required. • Alarm is fully operational during mute cycle and will realarm if hazardous conditions recur. • Built for the extreme RV environment. • Power 12 VDC, operational range 8-16 volts. Operational temperature range: -40°F to +150°F (-40°C to +66°F). • UL listed for recreational vehicles and unconditioned areas to detect LP gas/ propane and natural gas. • 1-yr. limited warranty.

*Recess Case 6.5"W x 2.875"H x 1.25" D:*

**57461** Almond #30-442-AL 12

**57462** Brown #30-442-BR 12

**56870** White #30-442W 6



## SAFE-T-ALERT MINI SERIES LP GAS ALARM

Meets requirements set by RVIA for LP Gas Alarms on RVs. Features: • Test/Reset Button - mute alarm during ventilation. Tests all detector functions with one touch. No dangerous test gas required. • Wide operational range, 8 to 16 volts avoids most low voltage alarms. • Alarm is fully operational during mute cycle and will re-alarm if hazardous conditions recur. • Easy quick slide installation on mounting bracket. • Built for the extreme RV environment. UL listed for Recreational Vehicles and Unconditioned Areas. • One Year Limited Warranty.

### SPECIFICATIONS

- Operating temperature: -31°F to +150°F.
- Surface mount: 3.5" W x 2.5" H x 1.25" D.
- Power supply and current draw: 12-vDC, 75mA. Alarm Point: <25% LEL of propane and methane.

**57256** Mini Propane Alarm, White #20-441-WT 12



57006

## ATWOOD CO GAS ALARM

Easy to read digital display clearly indicates CO levels. The Atwood Battery Powered CO Alarm incorporates sophisticated electronic components to protect family members from the dangers of Carbon Monoxide. Updates CO level readout every 15 seconds. Uses 3 "AA" batteries (not included). 5.5" x 1.625".

*Digital Display Model (Shown):*

**57006** CO Alarm #32519 1

*Non-Digital Display Model:*

**56988** CO Alarm #32521 10



57475



57476

## SAFE-T-ALERT DUAL CO / GAS ALARM WITH RELAY

### 70 SERIES - DUAL PROPANE/LP AND CARBON MONOXIDE ALARM

Safe-T-Alert combination Carbon Monoxide/ LP Gas Alarm Kit with Relay value control and Solenoid valve. Sounds an alarm and turns your gas supply off if a propane leak is detected. Also detects carbon monoxide fumes and sounds an alarm. The dual alarm kit replaces CCI Controls flush and surface mount Pre Tell LP Gas Detectors with valve control.

**Features Include:** • Meets 1/1/05 requirements set by RVIA for new RV's requiring both Propane detectors and CO alarms. • Also detects Compressed Natural Gas (CNG)/Methane. • Includes 3 amp relay to control solenoid valve to halt gas flow or shut down a generator during an alarm. • Interconnect up to 9 alarms. When one unit sounds an alarm all connected units sound the alarm. • Test/Reset Button - Tests all detector functions with one touch. • Resets and Mutes alarm while safety and corrective actions are taken. • Alarm is fully operational during mute cycle and will re-alarm if hazardous conditions reoccur. • RV 12 Volt Hard Wired Model. Prevents accidental disconnection during alarm. • Built for the extreme RV environment. 1-year Limited Warranty. • UL listed for Recreational Vehicles and Unconditioned Areas.

**Operating Specifications:** • UL Listing Propane/Natural Gas - UL 1484 RV Gas Detectors. • UL Listing Carbon Monoxide UL 2034 RV Carbon Monoxide Alarms. • ULC Listing & CSA 6.19-01. • Power Supply and Current Draw 12 vDC 132 mA - Optional Relay 12 vDC - 3 amp. • Operational Voltage: 12 Volt +/- 15% - Low voltage power warning alarm @ 7 volts. • Case Size : 6.375"W x 3.5"H x 1.385"D .

*Combination Carbon Monoxide/  
LP Gas Alarm Kit with Relay:*

**57476** Brown #70-742-R-BR-KIT 12

**57475** White #70-742-R-WT-KIT 12

**SAFE-T-ALERT CARBON MONOXIDE DETECTORS**



Meets Recreational Vehicle and Residential UL Standard 2034, plus it has a special recognition circuit that requires the occupant to respond to the **85db alarm at 10 feet** by pressing the reset switch. Because disorientation and confusion are common effects of CO poisoning, the detector makes a further effort to make the occupants properly respond to the alarm. Unit also retains the level of CO detected at the time of alarm. When you ventilate the area after an alarm it is impossible to determine how much CO was present unless your detector has a memory. This important tool eliminates guess work for you, service personnel and emergency responders. Also has a warning alarm that will activate within 4 hours after a constant exposure to 60ppm of carbon monoxide. Detector features include: audible and visual malfunction alarms, double check confirmation circuit that will sound if CO is still present 6 minutes after the first indication of CO, fast installation and a circuit board that's never exposed. Case size (surface): 5 1/2" x 3" x 1 1/3"; (flush): 6 1/2" x 3 1/2" x 1 1/4". 12VDC. Current draw: 60 milliamps.

Safe-T-Alert CO Detector:

**50883** Surface Mounted #60-541 [6](#)

**50884** Recess Mounted #60-542 [6](#)

**SAFE-T-ALERT**



50886  
Recess  
mount

**SAFE-T-ALERT 40 SERIES-The RVers Choice LP GAS ALARM**

**Designed for the Rugged RV Environment.**

Ideal for Class A Motor Homes, Class B Van Campers, Class C Mini-Motor Homes, Travel Trailers, Fifth Wheels, Truck & Folding Campers. – **Fully Operational During Mute.** Mute does not override detection circuit, giving you full time protection. – **InteCheck™ Circuit** - No false alarms from temporary exposures to LP Gas/Propane, aerosol cleaners, hair spray and other flammable gases. – **Micro Current Technology.** Saves precious battery power. – **Long Life, Self Cleaning Sensor.** Maintenance free built-in sensor. – **Loud 85dB Alarm.** Alerts you to the presence of hazardous propane vapors. – **Test/Reset Button.** Used to temporarily silence alarm during ventilation. Tests all the detectors functions with one touch. – Operates on 12VDC. – Dimensions: 4.8"W x 3.4"H x 1 1/4"D. – **3 Year Limited Warranty.** – Light Gray.

LP Gas Alarm #40-442RV:

**50886** Recess Mounted #40-442-WT [6](#)

**MTI INDUSTRIES SAFE-T-ALERT COMBINATION CARBON MONOXIDE AND PROPANE ALARM**

Double your protection by replacing your old propane alarm with



one that detects two threats to your family's safety. Dual Alarm detects both carbon monoxide and propane gas inside an RV. Also detects CNG. 12-volt installation replaces current propane alarms in all RVs. Flush mount design saves space. 6.5" W x 3.5" H x 1.4" D. Test/Reset button. Mute alarm during ventilation. Test with one touch; no dangerous gas required. UL listed to operate at extreme temperatures (-40°F to +150°F) to detect both gases. No false alarm sensor technology. Operational down to 7-volts. 5-yr. mfr. warranty.

**57047** Combination Carbon Monoxide and Propane Alarm #70-742RV [1](#)



**30 SERIES SLIM LINE LP GAS ALARM**

UL® listed for RV use. The Slim Line surface mount case eliminates cutouts. A dual Test and Mute switch checks the alarm's functions and can silence the audible alarm for two minutes. During the mute cycle the sensing circuit is continually operating giving you constant protection. Only 6" W x 2" H x 2" D. The 30-441 operates on 12 VDC battery power. One year limited manufacturer's warranty. Light gray.

**56914** Slim Line LP Gas Alarm #30-441-WT [12](#)

**SAFE-T-ALERT THE RVING CHOICE!**

**STAY ALERT WHILE RV'ING**

**POTENTIAL SOURCES OF CARBON MONOXIDE**

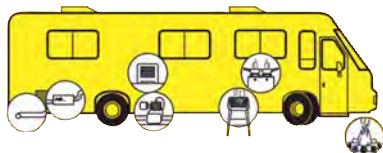

- Engine Exhaust • Portable Grills
- Portable Space Heaters • Camp Fires
- Gas Stoves and Ovens • Other RVs
- Defective Engine • Portable Generator
- Exhaust System • Generator Exhaust

**POTENTIAL SOURCES OF LP GAS LEAK SOURCES**

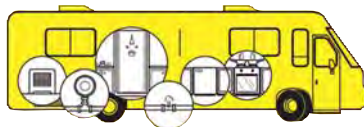

- Stove top burners • Refrigerator
- Oven • Other Propane Appliances
- Furnace • Defective LP Gas Connection
- Water Heater • Defective Regulator

Graciously provided by Safe-T-Alert™

**SAFE-T-ALERT**

**SAFE-T-ALERT SMOKE ALARM WITH SILENCER**



- Press alarm Mute button to silence alarm while smoke is cleared. • Easy to install. • 9 volt battery included. • Dim.: 4.25" diameter x 1" deep.
- Meets RVIA / ANSI standards for smoke alarms installed in RV's. • UL listed. • Retail packaging.

**57479** Smoke Alarm with Silencer #SA-775 [24](#)

In Section K:

Alarms & Leak Detectors

LP Tanks & Accessories

Valves & Fittings

Regulators

Pigtails & Hoses

## KIDDE BATTERY OPERATED CO DETECTOR



The Kidde permanent electrochemical sensor uses highly accurate CO sensor technology. The alarm alerts you if carbon monoxide levels become dangerous. Detector is battery operated, providing protection even during power outage. The test/reset button tests the unit's electronics and silences the sounder alarm. Battery included.

**Features:** • Updates every 15 sec. • Flashing green LED power indicator. • Steady On Red LED alarm light. • Piercing 85dB alarm horn. • Front loading battery door. • Three AA batteries are included. • UL listed. • 5-yr. mfr. warranty.



**56804** Kidde CO Detector #9C05-02 3

## KIDDE BATTERY OPERATED IONIZATION SMOKE DETECTORS



Kidde Fyrenetics battery operated smoke alarms require no wiring and include all batteries necessary for operation. Suitable for installation on walls or ceilings in all rooms.

**Features:** • Ionization sensor. • Low battery indicator. • Test button. • 9V battery powered. • Flashing red LED power on indicator. • Piercing 85dB alarm horn. • Low profile design. • UL listed.

**50726** Kidde 0914 Micro Smoke Detector (Not available in Canada) #0914E 12

### MODEL 0915

In addition to all the features of the 0914, the 0915 also has a tamper proof locking pin and a 5-yr. mfr. warranty.

**50480** Kidde 0915 Smoke Detector (Not available in Canada) #0915 12



White Base Plate, Wingnut, Hold Down Bar and Regulator Bracket



## MANCHESTER BOTTLE RACKS

Saf-T-Grip Complete Assembly; For Tanks of:

- 50021** #20, 18" Center Rod #1801 1
- 50022** #30, 24" Center Rod #1803 1
- 50023** #40, 30" Center Rod #1811 1

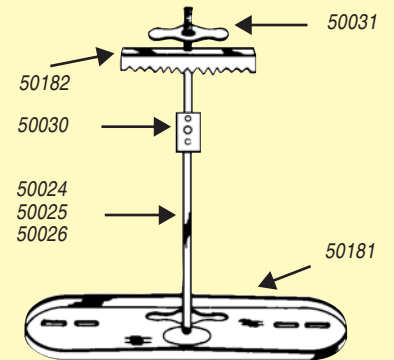

Accessories for Saf-T-Grip:

- 50024** #20 Center Rod, 3/8" x 18" #1805 1
- 50025** #30 Center Rod, 3/8" x 24" #1806 1
- 50026** #40 Center Rod, 3/8" x 30" #1807 1
- 50030** U-Mounting Regulator Bracket #A82848 1
- 50031** Wingnut, 3/8" #1809 1
- 50181** Dual Rack Base, White, Powder Paint, 3/8" nut #1810.3A 1
- 50182** Hold Down Bar, 3/8" #1588 1



50623

## OPD PROPANE GAS TANKS

DOT certified propane cylinders contain a stopfill valve and OPD. Powder coated.

**50623** 20 lb. DOT Tank, (5 gal.), 12" Dia.; 18" O.L.; 18 lb. empty (ACME, without gauge) #YSN201 1

**50617** 30 lb. DOT Tank, (7.5 gal.) 12" Dia.; 24" O.L.; 25 lb. empty (ACME, without gauge) #YSN301 48

**50618** 40 lb. DOT Tank, (10 gal.) 20" Dia.; 30" O.L.; 36 lb. empty (ACME, without gauge) #YSN401 24

50617



## STROMBERG CARLSON SINGLE LP GAS BOTTLE RACK

**50489** 20 lb. "J" Rack #2020-JR 5



## HONG'S HENG'S PROPANE TANK STRAPS

Safely secures propane tanks in RVs.

Gas Bottle Strap:

- 50645** Single #90032 25
- 50646** Double #90033 25





50621

**MANCHESTER  
OPD SERIES DOT CERTIFIED  
PROPANE GAS TANKS**



Fig. 2  
50624



50616

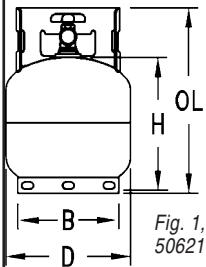
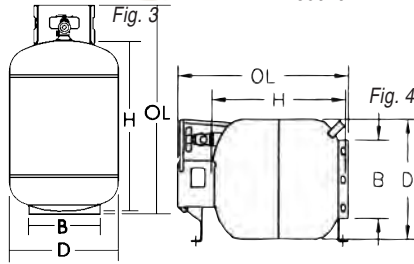

Fig. 1,  
50621



**FIG. 2: 11-20 LB VERTICAL TANKS**

Manchester Tank & Equipment's SureFlame 20# Steel TC/DOT Vertical LP Cylinder is perfect for propane grills, portable cooking, fueling propane appliances, temporary heating and other outdoor applications.

- Featuring the SureFlame Gauge - the most effective liquid level gauge available.
- Cylinder conforms with strict compliance to DOT specification 4BA240 and Transport Canada specifications 4BAM16.
- HANDLE-EZ collar design - the only collar with a built-in, formed handle with no sharp edges.
- White powder coat paint for maximum rust protection.
- Cylinder is pre-purged and ready for filling.
- English and French Consumer Warning & Purging Labels.
- Made in the U.S.A. White.

**50624** #20 SG DOT, 12.2" Dia.; 13.9" H x 18" O.L. x 8" Dia. B; 4.6 Gal., 19 lb. LPG, 18 lbs. T.W. (ACME/OPD, with gauge) #10504TC.101 1

**FIG. 4: HORIZONTAL-MOUNT COMPARTMENT TANK**

20 lb. horizontal LP tank mounts in a standard compartment. Can be used in a horizontal position; must be filled vertically. Has front and rear brackets for secure mounting. Acme/Type 1 with OPD and gauge. White.

**50616** #F-20AHB-SG, 12.2" Dia.; 13.9" H x 17.4" O.L. x 7.9" Dia. B; 4.6 Gal., 20 lb. LPG, 21 lbs. T.W. #10487TC 1

**MANCHESTER  
HORIZONTAL 30# RV GAS CYLINDER**

These LP units are powder-coat painted for maximum rust protection. Easy-to-grab collar design has a built-in, formed handle with no sharp edges. Horizontal Acme/Type 1 with overfill prevention device and gauge. White.

**56835** LP Cylinder, 30# Propane Capacity (6.8 gal.), 19.6" H x 23.4" O.L. x 12.2" dia.; 7.9" Dia B.; 31 lbs T.W. #1175TC 1



50578



**MANCHESTER  
LP GAS TANKS  
WITHOUT  
DIAL CHAMBER**



54816  
Sold  
separately!

**FOR MOTORHOMES**

ASME Tank without dial chamber:  
**50578** 12" Dia. x 28"L, 9.76 Gal., 53 Lb.; Centerline Valving with Top Angle Brackets #6840 1

**50582** 12" Dia. x 32"L, 11.28 Gal., 69 Lb.; 6 Universal Corner Brackets #6817 1

**54426** 14" Dia. x 40"L, 19.36 Gal., 81 Lb.; 6 Universal Corner Brackets #6828 1

ASME Tank Accessories:

**54816** Standard Dial Chamber, Snap on Mount #G12653 6

**FOR  
VAN  
CONVER-  
SIONS**



Ford, Dodge & Chevrolet.

ASME Tank without dial chamber; Lower 45 Valving with Adjustable Channel Brackets:  
**50584** 10" Dia. x 23"L, 5.52 Gal., 43 Lb. (Shown) #6813 1

**50585** 10" Dia. x 32"L, 7.92 Gal., 46 Lb. #6814 1

**50579** 8" Dia. x 42"L, 6.72 Gal., 51 Lb. #6811 1

ASME Tank Accessories:

**54816** Standard Dial Chamber, Snap on Mount #G12653 6



**CAVAGNA  
GASGARD UNIVERSAL  
PROPANE GAS MONITOR GAUGE**

The Type 1, QCC1 Fuel Indicator can be used on grills manufactured after 1995 (Ducane or Weber after 1999). The AD-2G is a "quick on" ACME connection at both ends for ease of installation. Features a leak detector and refill indicator, and a positive seal mechanism that prevents gas flow until appliance is fully connected.

**56736** Gasgard LP Gauge #66-C-290-0010 1

In Section K:

Alarms & Leak Detectors

LP Tanks & Accessories

Valves & Fittings

Regulators

Pigtails & Hoses

## FLAME KING PROPANE GAS METER WITH GLOW-IN-THE-DARK DIAL

Never run out of propane again with this easy to read Glow-In-The-Dark Dial propane meter. Solid brass meter connects easily - no tools required. Features emergency flow controller and fire shut-off. Fits all propane appliances with Type 1 connection. Multi-color level indicator prevents wasting propane.

**15327** Propane Meter #YSN-212 *36*



Never run out of gas again!  
Use it over & over again!



## MANCHESTER 100 LB. DOT MOBILE HOME LP CYLINDER

LP quality cylinder is triple tested to tough standards; powder coat painted for maximum rust protection. Features the Easy-to-grab collar design with no sharp edges. Equipped with 10% valve to prevent overfilling. Propane capacity: 1 00 lbs. (22.9 gal.) Dimensions: 46.6" overall height, 41" tank height, 15.1" dia. *Not an OPD RV tank; used for mobile homes, fireplaces, etc.*

**50465** 100 lb. Cylinder for Mobile Homes , 14" Dia. B, 70 lb. #1428 *1*

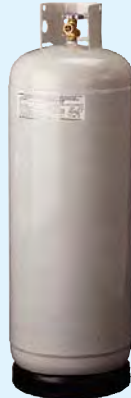

## ADCO PROPANE TANK COVERS

Protect propane bottles while in storage with this deluxe heavy-duty vinyl cover. Molded nylon zipper combined with a pressed wood top creates a more rugged and weatherproof cover (wood top not needed on single model to hold shape). Hollow bead welt cord and elastic shock cord provide a longer life and a neat tailored fit.

LP Tank Cover for Single Tank, Polar White:

**86025** For 20#, 5 Gal. #2111 *g*

LP Tank Cover for Double Tanks, Polar White:

**86026** For 20#, 5 Gal. #2112 *g*

**86028** For 30#, 7.5 Gal. #2113 *g*

**86029** For 40#, 10 Gal. #2114 *g*



## CRAMER DECKER HANDWHEEL FOR NON-OPD VALVE

Handwheel only for the old-style Sherwood LP Gas Cylinder valve (does not fit OPD valve).

**50207** Handwheel #3329-7 *5*



## CAMCO PROPANE TANK COVER FOR 20 LB DOUBLE TANKS

Heavy duty polypropylene cover protects propane gas bottles from flying debris while streamlining the look of your rig. Slip the custom molded assembled unit over bottles for a safe, secure fit and UV protection against sun damage. Updated design provides easier access to gas valves and changeover valves.

**87486** Propane Tank Cover, For 20 Lb Double Tanks, Polar White #40523 *4*



## CAMCO HEAVY DUTY PROPANE TANK COVERS

Heavy duty polyethylene covers protect propane gas bottles from flying debris while streamlining the look of your rig. Slip the custom molded, assembled unit over bottles for a safe, secure fit and UV protection against sun damage. Updated design provides easier access to gas valves. For single or double bottles, 20 lb. or 30 lb.

Heavy Duty Propane Tank Cover:

**85931** Polar White #40542 *4*

**85932** Colonial White #40532 *4*



## CAVAGNA ACME CYLINDER VALVES WITH OPD

For use on DOT cylinders up to 40 lbs. LPG capacity (96 lbs. water capacity). Valves are equipped with vapor service outlet, relief valve, captive fixed liquid level gauge, and Overfill Prevention Device. Features: • Rapid purging and filling with over one million BTU withdrawal capacity. • Double "O-ring" stem seal for improved leak resistance. • Includes Ever-Seal sealant (pre-applied). • Quality "O-ring" check valve seat opens only with positive seal. • High capacity BTU withdrawal allows fast purging and filling. • Upward spray filling - eliminates premature shutoffs. • Tri-lobular one-piece forged brass handwheels.

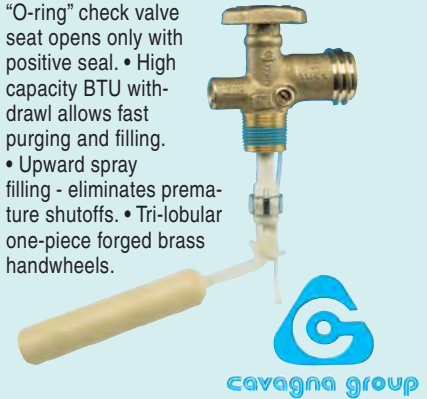

OPD Valves:

**57296** For 30# Steel or 6# or 20# aluminum cylinder (recommended dip tube: 4.8" L) #80-9-890-8184 *1*

**57297** For 40# Steel cylinder (recommended dip tube: 6.5" L) #80-9-890-8185 *24*

## INLINE OPD VALVE

The In-line OPD valve doesn't restrict valve output and doesn't slow down purge. It's all inline—there is no output-limiting orifice inside, and the float's inline (no awkward float arm). Maximum output is 1.9 million BTU per hour at 100 lbs pressure. Allows full strength operation of any size torch, heater, or other appliance. RV owners can be comfortable, even at sub-zero temperatures. Purges quickly, just as fast as if the OPD wasn't there. The unit is sturdy and compact, easy to store, handle and install. The OPD valve allows a matchup with a cylinder's required dip tube length. Inlet: 3/4" NGT; outlet: female POL and 1 3/16" male ACME.

**56775** For 20# steel or 10# aluminum cylinder (recommended dip tube: 4" L) #80-9-890-8180 *28*

SEE PAGE 219 FOR MORE TANK COVERS!

In Section K:

Alarms & Leak Detectors

LP Tanks & Accessories

Valves & Fittings

Regulators

Pigtails & Hoses

**MANCHESTER ROCHESTER  
ADVANCED MATRIX FILM  
TWINSITE REMOTE GAUGE SENDER**



The 2-wire TwinSite™ sender has a laser trimmed, advanced matrix film resistance element to provide continuous and more reliable signals with less noise. Plastic case is sealed hermetically into one solid piece; this keeps weather out, ensures “no-fog” readability, greatly extends mechanical life, withstands vibration and shock that would render comparable metal designs useless, and is far more resistant to corrosion than any metal case version. The plastic lens and case is of a UV stabilized material. Sender is magnetically driven with variable resistance, with two plotted lead wires and weather proof cable-end connectors.



**50477** 90 ohm Remote Sender, Snap on Mount #G12846 48



57565

**NEW!**

57563

**MARSHALL EXCELSIOR  
DOUBLE CHECK FILLER VALVE**

**57563** Fill Valve, 1-3/4" AMCE x 3/4 MNPT, with Cap #ME601-6 100

Replacement Parts for Check Filler Valve:

**57565** 1-3/4" F. ACME Yellow Plastic Cap #ME109 100

**57567** 1-3/4" ACME Gasket #MEW2 50

**White  
Rodgers**



50216



50280



50426

**WHITE-RODGERS  
UNIVERSAL  
REPLACEMENT THERMOCOUPLES**

Heavy-duty thermocouples.

Universal Replacement Thermocouple:

**50216** 18" #H06E018S1 10

**50217** 24" #H06E024S1 10

**50218** 30" #H06E030S1 10

**50219** 36" #H06E036S1 10

**RECTORSEAL #5  
PIPE THREAD SEALANT**

Slow dry, soft set, non-seizing...breaks out easily without damaging threads. Ideal for gas, water, oil or butane.

**50426** 1 3/4 Oz. Tube #25790 TUBE 24

**50280** 1/4 Pint Can #25631 1



**NEW!**

**MARSHALL  
EXCELSIOR  
LP OPD FILLER VALVE  
DUST CAP & STRAP**

Designed to protect the 1-5/16" male Acme threads on Type 1 (QCC) or OPD type cylinder valves. Using a cap will reduce the likelihood of inadvertent damage to the cylinder threads, shutoff mechanisms and sealing surfaces during storage or refurbishment.

**57566** Dust Cap for POL #ME952-07 100

**TEFLON TAPE  
FOR LP GAS**

**SPECIALTY  
YELLOW ZIP TAPE**

Designed for sealing lines carrying natural gas, propane, butane, as well as, oil and chemical installations. CSA approved. UL Listed thread sealant 131N. 1/2" x 260".



**27840** Yellow Teflon Tape #YT70 24



**CRAMER DECKER  
ASME P.O.L. VALVE  
WITH OUTAGE  
AND RELIEF**



Safety relief is set at 312 psi for use on small ASME motor fuel tanks with 20 sq. ft. or less in surface area. 3/4"-14 NPT inlet; P.O.L. outlet. Flow rate 705 CFM air. 1/card.

**50409** High Flow LP Valve #PVE3250BC-312 1



**NEW!**

**MARSHALL EXCELSIOR  
LIQUID LEVEL  
VENT VALVE**



**57562** Fixed Liquid Level Vent Valve, Brass #MEJ400 100



**NEW!**



57545

**MARSHALL EXCELSIOR  
MALE POL X 1/4" MNPT**

.9 GPM Excess Flow, Male POL x 1/4" MNPT:

**57545** Soft Nose, Plastic Handwheel, Bulk #ME1653 150

**57546** 7/8" Hex, Bulk #ME1690 175

**57547** 7/8" Hex, CD/1 #ME1690P 33



**MARSHALL  
EXCELSIOR  
RV BULKHEAD  
& ADAPTER**



57497



**NEW!**

**MARSHALL EXCELSIOR  
RV BULKHEAD  
& ADAPTER**

**57497** 1/4" Female inverted flare x 1/4" MPT Single Pc Adapter #ME2132 1000

Accessory:

**57549** 1/4" Inverted Flare Plug with knob #ME2131 1000



57549

In Section K:	Alarms & Leak Detectors	LP Tanks & Accessories	Valves & Fittings	Regulators	Pigtails & Hoses
---------------	-------------------------	------------------------	-------------------	------------	------------------

## MARSHALL EXCELSIOR CAMPING TEES

**Warning:** An excess flow valve will not activate if there is a break or leak downstream of the valve that does not equal or exceed the closing flow of the valve or if the excess flow valve installed exceeds the flow capacity of the system.



Order #	Mfr. #	Inlet	Auxiliary Inlet	Outlet	Outlet	Packaging	Price
<b>57550</b>	#ME414P	1"-20 Female	-	1"-20 Male	1"-20 Male	Carded	
<b>57551</b>	#ME415P	.9 GPM Excess Flow Male Hard Nose POL	-	Female POL	1"-20 Male	Carded	
<b>57552</b>	#ME420P	.9 GPM Excess Flow Male Hard Nose POL	1/4" Female Inverted Flare with Check	Female POL	1"-20 Male	Carded	
<b>57553</b>	#ME422	1-5/16" Female Acme	1/4" Female Inverted Flare	1-5/16" Male Acme/Female POL with Quick Closing Poppet	1"-20 Male	Bulk	



### AUTOMATIC CHANGEOVER REGULATOR KIT by CAVAGNA NORTH AMERICA

Kit Includes Mounting Bracket And Plastic Cap Cover

- Automatically switches from empty service cylinder to full reserve cylinder, ensuring continuous gas flow to appliances. • Highly visible full/empty indicator signals need for refill. • Built-in back check valve allows empty cylinder removal and refill as reserve cylinder remains operational.
- Adjustable pressure setting. • 160,000 BTU/hr - Inlets: (2) 1/4" inverted flare, Outlet: 3/8" FPT. • Kit includes mounting bracket for easy installation, and plastic cap cover required by RVIA. • UL listed: USA/Canada.

#### SAFETY FEATURES:

- **Built-In Back Check Valve:** allows empty cylinder removal and refill as reserve cylinder remains operational. • **Excess Flow Device:** ensures protection with all hose connections. Limits gas flow in the event of hose rupture or accidental disconnection. • **Overpressure Protection Device:** Limits environmental propane release in case of regulator malfunction to a value less than 2 psi, significantly lower than that mandated by UL standard 144.

Automatic Changeover Regulator Kit (Includes bracket and cover):

- 57560** **NEW!** Box #70-A-190-0016 12
- 57066** Clamshell #70-A-190-0014 12

### TWO-STAGE REGULATOR KIT by CAVAGNA NORTH AMERICA

Kit Includes Mounting Bracket And Plastic Cap Covers

- A combination regulator; first stage reduces cylinder outlet pressure to 10 psi, and then second stage maintains a stable working pressure of 11" water column. • 160,000 BTU/hr - inlet: 1/4" FPT, Outlet: 3/8" FPT. • Kit includes mounting bracket for easy installation, and plastic cap covers required by RVIA. • UL listed: USA / Canada.

#### SAFETY FEATURES:

- **Excess Flow Device:** Ensures protection with all hose connections. Limits gas flow in the event of hose rupture or accidental disconnection. • **Overpressure Protection Device:** Limits environmental propane release in case of regulator malfunction to a value less than 2 psi, significantly lower than that mandated by UL standard 144.

Two-Stage Regulator Kit (Includes bracket & covers):

- 57561** **NEW!** Box #70-A-190-0017 12
- 57067** Clamshell #70-A-190-0010 1



Second Stage Cover

First Stage Cover

**MARSHALL GAS CONTROLS  
290-00 TWO STAGE REGULATOR**

The first stage features a lever arm that improves both the efficiency and regulation. Combined with the second stage regulator, the overall performance assures even smoother and more continuous flow of gas to all appliances. Model 294-00 has an excess flow P.O.L. installed. When mounted horizontally, its vent is pointing down. When mounted under a protective cover it is approved for use on single vertical cylinders or horizontal tanks. Series 290 specifications: zinc die cast, molded rubber diaphragms, fabric reinforced first stage diaphragm, 2nd stage relief mechanism per UL 144, mounting holes 3 1/2" on center, 90,000 BTU capacity, inlet: 1/4", outlet: 3/8" FPT inlet x 3/8" FPT outlet. 5 3/4" L, 3 1/8" W, 2 5/8" H; 1 lb.

*1-Piece 2-Stage Regulator (complies with RVIA-OEM requirements when properly protected and mounted with vent pointing down):*

**50518** Bulk #290-00 25

**50532** Same as 290-00, but with 9:00 Vent, Bulk #299-00 25

*1-Piece 2-Stage Regulator with Excess Flow P.O.L. (complies with RVIA-OEM requirements for use on single bottle and horizontal ASME tanks when properly protected and positioned with vent pointing down.)*

**50522** Bulk #294-00 25

**50879** Carded #294-00P 6

290 Series Regulator Covers:

**50285** Covers f/1st & 2nd Stage f/#290-00 In Bag with Header Card #863-00P 6



**MARSHALL  
EXCELSIOR  
REGULATORS &  
ACCESSORIES**



**NEW!**

Order #	Mfr. #	Description	Packaging	Price
<b>57500</b>	#MEGR-9950	2 Stage End Vent Regulator 1/4" FPT x 3/8" FPT	Bulk	
<b>57501</b>	#MEGR-9954	2 Stage End Vent Regulator	Bulk	
<b>57502</b>	#MEGR-9954P	Excess Flow POL x 3/8" FPT	Packaged	
<b>57503</b>	#MEGR-9959	2 Stage Side Vent Regulator 1/4" FPT x 3/8" FPT	Bulk	
<b>57498</b>	#MEGR-9984	2 Stage Auto Change Over Regulator,	Bulk	
<b>57499</b>	#MEGR-9984P	1/4" INV x 3/8" FPT	Packaged	
<i>Covers for Regulators:</i>				
<b>57544</b>	#MEGR-5950	2 stage regulator cover for MEGR-9950	Bulk	
<b>57568</b>	#MEGR-5984	Auto Change Over Regulator cover for MEGR-9984	Bulk	

**MARSHALL GAS CONTROLS  
AUTOMATIC CHANGE  
OVER  
TWO-STAGE REGULATOR**



Second stage regulator cover (included in 50285)

Changeover feature allows users the benefit of uninterrupted fuel flow to the LP gas system. A gentle push on the sliding face plate will switch gas flow from the service cylinder to the reserve cylinder. The indicator changes from green to red, indicating that the service cylinder needs to be refilled. The regulator, when properly installed with protective cover, meets all the requirements for use on recreational vehicles. 135,000 BTU capacity for service cylinder, 75,000 BTU for reserve cylinder. 1/4" female inverted flare inlet x 3/8" FPT outlet.

*LPG Automatic Changeover Regulator:*

**50110** Carded #254-00P 6

**50472** Bulk #254-00 25

**REGULATOR COVER PACKAGE:** The second stage cover included in this package will fit the #254 second stage.

**50285** Package of Covers for 1st Stage (for #290) & 2nd Stage (for #254 and #290) #863-00P 6





# PIGTAILS & HOSES

LP GAS

**K**

In Section K:	Alarms & Leak Detectors	LP Tanks & Accessories	Valves & Fittings	Regulators	Pigtails & Hoses
---------------	-------------------------	------------------------	-------------------	------------	------------------

## MARSHALL EXCELSIOR THERMOPLASTIC HOSES



Flexible thermoplastic UL and CGA approved hose. These hoses are rated up to 350 psig working pressure with a 400 pound pull test rating. Each hose comes with two ends and fully crimped brass ferrules.

Warning: An excess flow valve will not activate if there is a break or leak downstream of the valve that does not equal or exceed the closing flow of the valve or if the excess flow valve installed exceeds the flow capacity of the system.

- 1/4" Hose ID.
- Listed by category (Connection; Connection).



Order #	Mfr. #	Approximate Length	Price
<b>.9 GPM Excess Flow Male POL, 7/8" Nut; 1/4" Male Inverted Flare</b>			
57504	#MER401-12	12" OAL	
57505	#MER401-15	15" OAL	
57506	#MER401-20	20" OAL	
57507	#MER401-24	24" OAL	
57508	#MER401-30	30" OAL	
57509	#MER401-36	36" OAL	
57510	#MER401-48	48" OAL	
57511	#MER401-60	60" OAL	
<b>Male Soft Nose POL, Plastic Handwheel; 1"-20 Male Swivel</b>			
57513	#MER407-48	48" OAL	
57514	#MER407-60	60" OAL	
57512	#MER407-144	144" OAL	
<b>3/8" MNPT; 3/8" Female Flare Swivel</b>			
57526	#MER410-24	24" OAL	
<b>3/8" Female Flare Swivel; 3/8" Female Flare Swivel</b>			
57528	#MER413-24	24" OAL	
57529	#MER413-36	36" OAL	
57530	#MER413-48	48" OAL	
57531	#MER413-72	72" OAL	
57527	#MER413-144	144" OAL	
<b>1"-20 Female Swivel; 1"-20 Male Swivel</b>			
57533	#MER421-60	60" OAL	
57532	#MER421-144	144" OAL	
<b>Female QCC, Type I Connection; 1/4" Male Inverted Flare</b>			
57515	#MER425-12	12" OAL	
57516	#MER425-15	15" OAL	
57517	#MER425-18	18" OAL	
57518	#MER425-20	20" OAL	
57519	#MER425-24	24" OAL	
57520	#MER425-30	30" OAL	
57521	#MER425-36	36" OAL	
57522	#MER425-48	48" OAL	
57523	#MER425-60	60" OAL	
<b>Female QCC, Type I Connection; 1/4" MNPT</b>			
57524	#MER426-15	15" OAL	
57525	#MER426-20	20" OAL	
<b>3/8" MNPT; 3/8" Female Flare Swivel</b>			
57534	#MER610-24	24" OAL	
57535	#MER610-30	30" OAL	
<b>1/2" Female Flare Swivel; 3/8" MNPT</b>			
57537	#MER611-24	24" OAL	
57536	#MER611-36	36" OAL	
57539	#MER611-40	40" OAL	



In Section K:

Alarms & Leak Detectors

LP Tanks & Accessories

Valves & Fittings

Regulators

Pigtails & Hoses



All hoses and pigtails come with a hang tag.

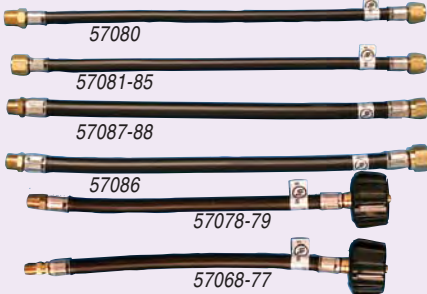

**LP GAS HIGH PRESSURE HOSES**

Thermoplastic high pressure hose assemblies, working pressure of 350 psi with 1700 psi burst rating. UL listed assemblies, CSA approved hose. Hang tagged for store display.

1/4" I.D. Hose - 3/8" MPT x 3/8" Female Flare Swivel:

**57080** 24" Long #50-A-190-0034 12

1/4" I.D. Hose - 3/8" FPT x 3/8" Female Flare Swivel:

**57081** 24" Long #50-A-190-0035 12

**57082** 36" Long #50-A-190-0048 12

**57083** 48" Long #50-A-190-0049 12

**57084** 72" Long #50-A-190-0050 12

**57085** 144" Long #50-A-190-0051 12

3/8" I.D. Hose - 3/8" MPT x 3/8" Female Flare Swivel:

**57087** 24" Long #50-A-190-0037 12

**57088** 30" Long #50-A-190-0052 12

3/8" I.D. Hose - 3/8" MPT x 1/2" Female Flare:

**57086** 36" Long #50-A-190-0036 12

**TYPE 1 ACME NUT PIGTAILS**

Pigtails are used with Double Stage Automatic Changeover Regulators for two cylinder systems or Standard Double Stage Regulators with "T" check connections. UL listed assemblies, CSA approved hose. Hang tagged for store display.

**Safety features:** Excess flow device: Limits gas flow in the event of hose rupture or accidental disconnection. Thermofuse: A heat sensitive plug, which shuts off gas flow if temperature reaches above 240° F.

Type 1 ACME Nut Pigtail x 1/4" Inverted Flare:

**57068** 12" Pigtail #50-A-190-0032 12

**57069** 15" Pigtail #50-A-190-0038 12

**57070** 18" Pigtail #50-A-190-0039 12

**57071** 20" Pigtail #50-A-190-0040 12

**57072** 24" Pigtail #50-A-190-0041 12

**57073** 30" Pigtail #50-A-190-0042 12

**57074** 36" Pigtail #50-A-190-0043 12

**57077** 60" Pigtail #50-A-190-0046 12

Type 1 ACME Nut Pigtail x 1/4" MPT:

**57078** 15" Pigtail #50-A-190-0033 12

**57079** 20" Pigtail #50-A-190-0047 12

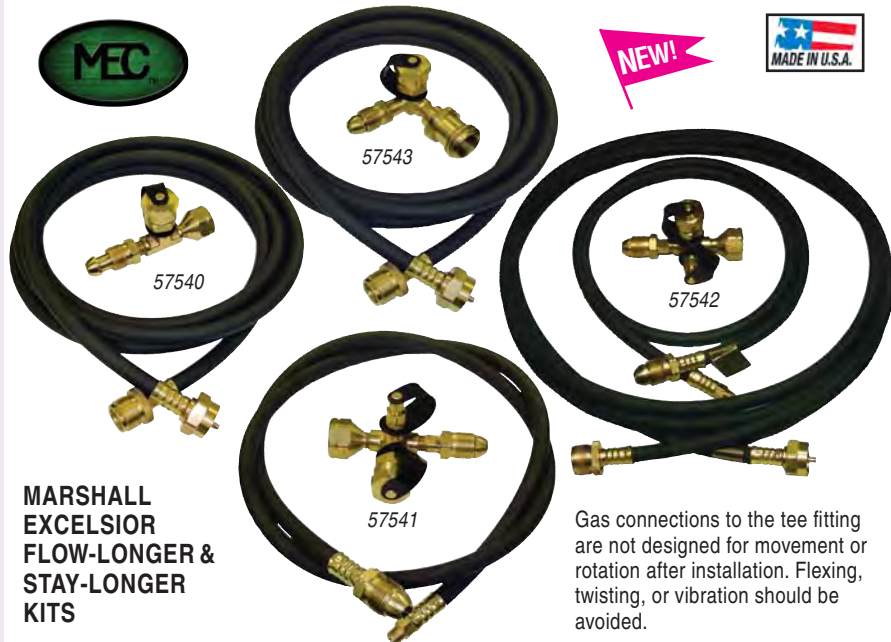

**MARSHALL EXCELSIOR FLOW-LONGER & STAY-LONGER KITS**

All kits include installation instructions and a convenient reusable box for storage.

Note: The tee fitting must be installed between the vapor withdrawal valve on your LP-Gas container and the pressure regulator. This properly places the tee fitting in the high pressure portion of the LP-Gas system.

The Flow-Longer Propane Kits are designed to connect small, portable appliances, normally fueled by disposable LP-Gas cylinders, to the existing LP-Gas fuel supply of a recreational vehicle, cottage, backyard patio, etc. without interrupting the supply of regulated fuel to the system. Flow-Longer eliminates the need to purchase an extra LP-Gas cylinder or several small, disposable type cylinders.

**MER470 Flow-Longer Propane Kit**

- Brass tee connection (ME415) .9 GPM excess flow male hard nose POL x female POL x 1"-20 male.
- 12 foot hose (MER421-144) 1"-20 male x 1"-20 female.

**57540** Flow-Longer Propane Kit #MER470 1

**MER471 Flow-Longer Plus Propane Kit**

- Brass elbow connection (ME423) .9 GPM excess flow male hard nose POL x 1-5/16" male Acme/female POL with quick closing poppet x 1"-20 female.
- 12 foot hose (MER421-144) 1"-20 male x 1"-20 female.

**57543** Flow-Longer Plus Propane Kit #MER471 1

Gas connections to the tee fitting are not designed for movement or rotation after installation. Flexing, twisting, or vibration should be avoided.

Warning: An excess flow valve will not activate if there is a break or leak downstream of the valve that does not equal or exceed the closing flow of the valve or if the excess flow valve installed exceeds the flow capacity of the system.

The Stay-Longer Propane Kits are designed to give you new flexibility on how you use your LP-Gas. You can stay longer by hooking up auxiliary LP-Gas cylinders, or you can tap into the RV's LP-Gas system to fuel portable high-pressure appliances.

**MER472 Stay-Longer Propane Kit**

- Brass tee connection (ME420) .9 GPM excess flow male hard nose POL x female POL x 1"-20 male x 1/4" female inverted flare.
- 5 foot hose (MER401-60) .9 GPM excess flow male POL x 1/4" male inverted flare.

**57541** Stay-Longer Propane Kit #MER472 1

**MER473 Stay-Longer Plus Propane Kit**

- Brass tee connection (ME420) .9 GPM excess flow male hard nose POL x female POL x 1"-20 male x 1/4" female inverted flare.
- 5 foot hose (MER401-60) .9 GPM excess flow male hard nose POL x 1/4" male inverted flare.
- 12 foot hose (MER421-144) 1"-20 male x 1"-20 female.

**57542** Stay-Longer Plus Propane Kit #MER473 1

**SEE CAMPING (SECTION B) FOR BARBECUE GAS ACCESSORIES**