

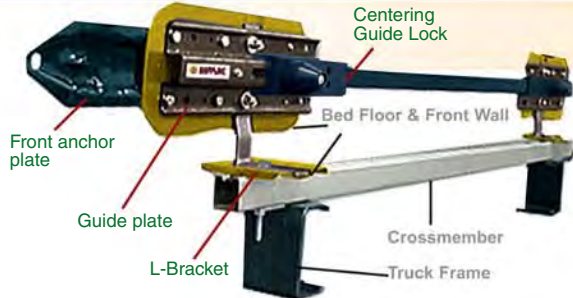

Direct-to-Frame Camper Tiedown Systems

By **HAPPIJAC**
A Division of Lippert Components Inc.



After extensive research Happijac Company has perfected an innovative Frame Mount Tiedown System that is three times stronger than other tiedowns and controls all aspects of securing a camper to a truck. While other tiedowns may "hold your camper down" only Happijac tiedowns prevent camper movement in all directions (forward-backward, up-down, left-right, yaw, pitch and roll). The Happijac Frame Mount System combines the proven design of Happijac Camper Anchor tiedowns with Happijac's patented Direct-to-Frame mount, providing the customer with unsurpassed strength, handling, and ease of use while also featuring quick and simple installation.

The complete Happijac Frame Mount Tiedown System consists of three components:

- (A) FT tiedown kit with centering guide locks (FT-UT9, FT-CG9, FT-CG07, FT-CG07S or FT-DR2).
- (B) Turnbuckles (FM-QLTB or FM-TB)
- (C) Stabilizing Bar (USB-010 or SB -020)

DIRECT-TO-FRAME TIEDOWN COMPONENT - (A)

By **HAPPIJAC**

FT Kit

(now includes centering guides)



CHEVY/GMC	Note	Order #	Mfr. #	Price
2007- 2011 Chev/GMC Silverado/Sierra (new body style), FT-CG07	1,3	86835	#182904	
2007- 2011 Chev/GMC (new body style)(except extended cab)*, FT-CG07S	1,3	87095	#182905	
1999- 2007 Chev/GMC Silverado/Sierra Classic, FT-CG9	1	73623	#182906	
1988- 2000 C/K Series (old body style), FT-UT9	1	73591	#182910	
DODGE	Note	Order #	Mfr. #	Price
NEW! 2010- 2011 Ram 2500, 3500, FT-DR10	5	87573	#236326	
NEW! 2009- 2011 Ram 1500, FT-DR10	5	87573	#236326	
2008- 2009 Ram (w/bed fr panel waffle-like pattern)(except 1500), FT-DR8	5	87241	#205220	
2003- 2008 Ram (w/bed front panel vertical ribs only) (Including 2002 Ram 1500), FT-DR2	2	75023	#182908	
1994- 2002 Ram (except 2002 Ram 1500), FT-UT9	1	73591	#182910	
2002 Dodge Ram 1500, FT-DR2	2	75023	#182908	
FORD	Note	Order #	Mfr. #	Price
2008- 2011 F450 SuperDuty, FT-UT9	1	73591	#182910	
1997- 2011 F250 SuperDuty & F350, FT-UT9	1	73591	#182910	
1980- 1996 F Series (all), FT-UT9	1	73591	#182910	
TOYOTA	Note	Order #	Mfr. #	Price
2007- 2011 Tundra (except 5-1/2" Bed), DF-TT07	4	87089	#184089	

TURNBUCKLE COMPONENT - (B)

By **HAPPIJAC**



TURNBUCKLE COMPONENT	Order #	Mfr. #	Price
Qwik-Load stainless steel Turnbuckle Set (2 FM-QLTBS & 2 FM-QLTBR), FM-QLTB	86295	#182895	
Stainless steel turnbuckle set (2 FM-TBS & 2 FM-TBR), FM-TB	73636	#182898	
Qwik-Load Lever Action Turnbuckle Upgrade, FM-QL	85722	#182894	

STABILIZING BARS - (C)

By **HAPPIJAC**



STABILIZING BARS	Order #	Mfr. #	Price
59.25" Stabilizing Bar (use with FM/FT UT9 & CG9), USB-10	73090	#182971	
57.375" Stabilizing Bar (use with FM/FT DR2), SB-020	75038	#182928	
56.875" Stabilizing Bar (use with FT DR8), SB-080	87240	#205221	
^{LS} 69" Stabilizing Bar (use with CA-UT8: 1980-98 Ford), SB-150	79687	#182930	
^{LS} 66.75" Stabilizing Bar (use with CA-DRL: 1994-02 Dodge Ram), SB-200	79688	#182931	

* If extended cab use FT-CG07. 1- Stabilizing Bar USB-010 Required, sold separately. 2- Stabilizing Bar SB-020 Required, sold separately. 3- Includes FM-CBB07. 4- Does not require Stabilizing Bar. 5- Stabilizing Bar SB-080 Required, sold separately.

CAMPER TIE-DOWNS

RV ACCESSORIES



In Section M: Starter Kits Vehicle Items Window & Door Interior Accessories Mats Steps Camper Tie Downs Wheel Chocks Ladders Carriers Winches Levelers Jacks

CAMPER ANCHOR TIEDOWNS

By HAPPIJAC

Happijac continues to offer their time tested Camper Anchor tiedowns. The scientific design of Happijac Camper Anchor tiedowns gives maximum strength while eliminating leverage and stress forces on the truck. Removable rear tiedown coupler rotates to direction of pull, eliminating undesirable torque. Happijac Camper Anchor tiedowns won't bend, twist or fail.

NOTE: Camper Anchor tiedowns do not mount to the frame as do the Happijac Frame Mount tiedowns. Camper Anchor tiedowns are not for use on full-size extended cab, crew cab, 4x4, diesel trucks or with campers over 2500 lbs. These applications require the Happijac Frame mount tiedowns (FT kit).



CHEVY/GMC	Note	Order #	Mfr. #	Price
1967-1972 C/K Series, CA-FU		S/O	#182862	
1973-2011 S-10, S-15, Canyon & Colorado, CA-UR	7	70486	#182866	
DODGE				
1994-2002 Dodge Ram (except 2002 Ram 1500), CA-DRL	6	S/O	#182858	
1991-1993 Dodge Ram, CA-FU	8	S/O	#182862	
1972-1990 Dodge Ram, CA-FU		S/O	#182862	
1997-2011 Dakota (except Crew Cab), CA-DK9		S/O	#182856	
1987-1996 Dakota, CA-DRL		S/O	#182858	
FORD				
2004-2011 F150, CA-FD4		S/O	#182860	
2004 - F150 Heritage, CA-FD7		S/O	#182861	
1997-2003 F150 & F250 under 8500 gvw (except crew cab), CA-FD7		S/O	#182861	
2011 and earlier Ranger, CA-UR	7	70486	#182866	
TOYOTA				
1989-2011 Toyota (only with campers under 1500 lbs.) (except Tundra), CA-UR	7	70486	#182866	
ISUZU				
1989-2008 Isuzu, CA-UR	7	70486	#182866	
MAZDA				
1994-2008 Mazda, CA-UR	7	70486	#182866	
NISSAN				
1998-2011 Nissan, CA-UR	7	70486	#182866	

- 6- Stabilizing Bar SB-200 recommended, sold separately.
- 7- Requires 4 ea, (sold individually).
- 8- Requires FK-DAK Fit Kit (sold separately).

PARTS, FIT KITS & ACCESSORIES

By HAPPIJAC



- 70486** Universal Rear Anchor, CA-UR #182866 1
- 73682** Chrome Anchor Bolt & Hardware, CA-AB #182852 1
- 70487** Chrome Coupler, CA-TC #182865 1
- 73686** ^{LS} Front Anchor Plates (Set of 2), FA-UT9 #182876 1
- S/O Front Anchor Plates (Set of 2), FA-CG07 #182870
- S/O Front Anchor Plates (Set of 2), FA-CG07S #182871
- 75014** ^{LS US only} Replacement Kit for FM/FT-CG9, FK-CG9 #182878 1
- 77785** Front Centering Guide Locks (includes 2 Rollers & 2 Bumpers), FM-FGL9 #182892 1
- S/O Bumper Brace (1999- 2010 Ford F-250 SD + F-350), FM-BB9 #182885
- S/O Bumper Brace (2007- 2010 Chev/GMC), FM-CBB07 #182887
- S/O Qwik-Load Front Spring-loaded Turnbuckle w/11" threaded hook (1 ea), FM-QLTBS #182897
- 73660** Front Spring-loaded Turnbuckle w/11" threaded hook (1 ea.), FM-TBS #182901 1
- S/O Qwik-Load Rear Stress-guard Turnbuckle w/24" threaded hook (1 ea), FM-QLTBR #182896
- S/O Rear Stress-guard Turnbuckle w/24" threaded hook (1 ea.), FM-TBR #182900
- 87094** Qwik-Load Long Action Spring Loaded w/40" reach (Set of 2), FM-QLLA #191380 1
- 87093** Long Action Spring-loaded Turnbuckle w/40" reach (Set of 2), FM-TBLA #191431 1
- S/O 24" Threaded hook (zinc plated - 1 ea.), TBH-24 #182970

For over 4 decades, Happijac has been a leader in the camper accessory industry. Their performance and innovation in the field is one of the longest in existence. Happijac's direct-to-frame tiedowns are the only system to control camper movement in all directions, and their turnbuckles are the strongest on the market. There's a lot riding on your Tiedowns and Jacks. That's why they have to be HAPPIJAC!





Frame Mounted Camper Tie Downs Application Guide

Step 1

CHOOSE YOUR FRONT TIE DOWNS

Does the truck have running boards that extend past the cab and onto the bed?

NO

YES

FRONT OR REAR TIEDOWN KITS INCLUDE:

One drivers and one passengers tiedown

Two pieces of 1/4" chain, long
Two Quicklinks

Turnbuckles Sold Separately
(see page 376 for accessories)

Get the right numbers right now using the online interactive application guide at:

www.torklift.com

Denotes limited supply!

FRONT TIEDOWNS

Year	Make/Model	Bed Length	E-Z INSTALL			Notes	Drill Holes
			Order #	Notes	Drill Holes		
FORD							
97-03	F150/F250 Lt Duty	8'	s/o F2001	∅		s/o F4001	4,5 ∅
97-03	F150/F250 Lt Duty	6.5'	39144	3	4	s/o F4002	4,5 4
98-03	F150 Super Crew	5.5	s/o F2009	∅			N/A
99-04	F250/F350 (All)	8'	39113	∅		s/o F4006	4,5 ∅
99-04	F250/F350 (All)	6.75'	39145	∅		s/o F4006	4,5 ∅
04-05	F150 (All)	8'	s/o F2003	∅			N/A
04-05	F150 (All/No Step Sd)	6.5'	39874	∅			N/A
04-05	F150 Super Crew	5.5'	s/o F2005	∅			N/A
05-07	F250 / F350 (All)	8'	39113	∅		s/o F4006	4,5 ∅
05-07	F250 / F350 (All)	6.75'	39145	∅		s/o F4006	4,5 ∅
05-08	F450 / F550 (All)	N/A	s/o F2008	∅			N/A
06-10	F150 (Super Crew)	5.5'	s/o F2010	∅			N/A
06-09	F150 (All/No Step Sd)	6.5'	s/o F2014	∅			N/A
08-10	F250/F350/F450 (All)	8'	30667	∅			N/A
08-10	F250/F350 (All)	6.75'	s/o F2012	∅			N/A
2011	F250/F350/F450 (All)	8'	s/o F2016	∅			N/A
00-10	Ranger	6'	s/o F2013	∅			N/A
DODGE							
94-01	1500 (All)	8'	39115	3	2	s/o D4100	4,5 ∅
94-01	1500 (All)	6.5'	30250	∅		s/o D4104	4,5 4
94-02	2500/3500 (All)	8'	39115	3	∅	s/o D4100	4,5 ∅
94-02	2500/3500 (All)	6.5'	30250	∅		s/o D4104	4,5 4
02-03	1500 (All)	6.5', 2WD	s/o D2106	∅			N/A
02-03	1500 (All)	6.5', 4WD	s/o D2105	∅			N/A
04-08	1500 (All)	8'	s/o D2107	3	2		N/A
04-08	1500 (Std, Quad)	6.5', 2WD	s/o D2106	∅			N/A
06-08	1500 Mega	6.5', 2WD	s/o D2111	∅			N/A
04-08	1500 (Std, Quad)	6.5', 4WD	s/o D2105	∅			N/A
06-08	1500 Mega	6.5', 4WD	39580	2	2		N/A
09-10	1500 (Quad, No Lar.)	6.5', 4WD	s/o D2113	∅			N/A
03-09	2500/3500 HD (All)	8'	39394	∅		39397	4,5 ∅
03-09	2500/3500 HD (All)	6.5', 4WD	39580	2	2	s/o D4102	4,5 2
03-09	2500/3500 HD (All)	6.5' 2WD	31724	2	2		N/A
06-09	2500/3500 Mega	6.5' 2WD	s/o D2111	∅			N/A
97-04	Dakota (All)	6'	s/o D2104	∅			N/A
05-10	Dakota (All)	6'	s/o D2109	∅			N/A
07-09	3500/4500/5500 CAB	N/A	s/o D2112	∅			N/A
2010	2500/3500 HD (All)	8'	31725	∅		39397	4,5 ∅

FOOTNOTES FOR APPLICATION CHART

- (1) SuperHitch Magnum requires the use of R3504.
- (2) Drilling required into **spring hanger** bracket, not into frame of vehicle.
- (3) Drilling may be required.
- (4) May require modification of running board bracket.
- (5) Additional labor required for installation.
- (6) Front tie down available only in adjustable style only.
- (7) 97 F150 & 97-03 light duty F250 models, use 97-03 F150/F250 LD application.
- (8) **Will also work on trucks without receiver hitch.**
- (9) HD tow pack attaches to side of frame, standard tow pack attaches to bottom of frame only.
- (10) 1500 HD vehicle owners please call 800.246.8132 to verify your correct application fit.

For Fast and Friendly Tech Support
1-800-246-8132



CAMPER TIE-DOWNS

RV ACCESSORIES



In Section M: Starter Kits Vehicle Items Window & Door Interior Accessories Mats Steps Camper Tie Downs Wheel Chocks Ladders Carriers Winches Levelers Jacks



TRUE

Frame Mounted Camper Tie Downs Application Guide

Step 2

CHOOSE YOUR REAR TIE DOWNS

Does the vehicle have a rear receiver hitch that is:

Factory

SuperHitch

Aftermarket

Step 3

Year	Make/Model	Bed Length	FACTORY			AFTERMARKET			Drill Holes
			Order #	Notes		Order #	Notes		
FORD									
97-03	F150/F250 Lt Duty	8'	39146	15				39114	12 8
97-03	F150/F250 Lt Duty	6.5'	39146	15				39114	12 8
98-03	F150 Super Crew	5.5	39146	15				39114	12 8
99-04	F250/F350 (All)	8'	39146	15		30771	18	39114	12 8
99-04	F250/F350 (All)	6.75'	39146	15		30771	18	39114	12 8
04-05	F150 (All)	8'	39875	8				39114	12 8
04-05	F150 (All/No Step S.)	6.5'	39875	8				39114	12 8
04-05	F150 Super Crew	5.5'	39875					39114	12 8
05-07	F250 / F350 (All)	8'	39921	15		30771	18	39114	12 8
05-07	F250 / F350 (All)	6.75'	39921	15		30771	18	39114	12 8
05-08	F450 / F550 (All)	N/A		N/A		30771	1,16	39114	12 8
06-09	F150 (All)	8'	s/o F3005					s/o F3005	8
06-10	F150 Super Crew	5.5'	s/o F3005					s/o F3005	8
08-10	F250/F350/F450 (All)	8'	39921	15		30771	18	39114	12 8
08-10	F250/F350 (All)	6.75'	39921	15		30771	18	39114	12 8
00-10	Ranger	6'	39921	15				39114	12 8
DODGE									
94-01	1500 (All)	8'	39147	15				39114	12 8
94-01	1500 (All)	6.5'	39147	15				39114	12 8
94-02	2500/3500 (All)	8'	39147	15		30771	18	39114	12 8
94-02	2500/3500 (All)	6.5'	39147	15		30771	18	39114	12 8
02-03	1500 (All)	8'	s/o D3103					39114	12 8
02-03	1500 (All)	6.5', 2WD	s/o D3103					39114	12 8
02-03	1500 (All)	6.5', 4WD	s/o D3103					39114	12 8
04-08	1500 (All)	8'	39395	8,11				39114	12 8
04-08	1500 (Std, Quad)	6.5', 2WD	39395	8,11				39114	12 8
06-08	1500 Mega	6.5', 2WD	39395	8,11				39114	12 8
04-08	1500 (Std, Quad)	6.5', 4WD	39395	8,11				39114	12 8
06-08	1500 Mega	6.5', 4WD	39395	8,11				39114	12 8
09-10	1500 Quad, No Larmi	6.5', 4WD	s/o D3107					39114	12 8
03-09	2500/3500 HD (All)	8'	39395	8,11		30771	18	39114	12 8
03-09	2500/3500 HD (All)	6.5', 4WD	39395	8,11		30771	18	39114	12 8
03-09	2500/3500 HD (All)	6.5' 2WD	39395	8,11		30771	18	39114	12 8
06-09	2500/3500 Mega	6.5' 2WD	39395	8,11		30771	18	39114	12 8
97-04	Dakota (All)	6'	s/o D3105					39114	12 8
05-10	Dakota (All)	6'	s/o D3106					39114	12 8
07-09	3500/4500/5500 Cab	N/A	N/A			s/o R3504	18	39114	12 8
2010	2500/3500 HD (All)	8'	31726	8,13		s/o R3505			
2010	2500/3500 (Quad)	6.5', 4WD	31726	8,13					

CHOOSE YOUR TURNBUCKLES:

See page 376



Denotes limited supply!



REAR TIEDOWNS

FOOTNOTES FOR APPLICATION CHART

- (11) Will work with aftermarket hitches that **do not** have side-plates.
- (12) Will **only** work with aftermarket hitches that have side-plates (4" x 4" mounting footprint required).
- (13) Will only work on truck without hitch.
- (14) On dually applications rear camper anchor point location may require the use of A7004.
- (15) Requires factory installed receiver w/open crosstube.
- (17) D1101M requires R3504 / D1102M requires R3503.
- (18) Will not work on welded single piece super hitches.

(H) Indicates that drilling will be required, and the number following designates the total number of holes drilled for installation (example: H4 = 4 holes drilled).

For Fast and Friendly Tech Support
1-800-246-8132





TRUE

Frame Mounted Camper Tie Downs Application Guide

Step 1

CHOOSE YOUR FRONT TIE DOWNS

Does the truck have running boards that extend past the cab and onto the bed?

NO

YES

FRONT OR REAR TIEDOWN KITS INCLUDE:

One drivers and one passengers tiedown

Two pieces of 1/4" chain, long
Two Quicklinks

Turnbuckles Sold Separately
(see page 376 for accessories)

Get the right numbers right now using the online interactive application guide at:

www.torklift.com

Denotes limited supply!

FRONT TIEDOWNS

Year	Make/Model	Bed Length	E-Z INSTALL			Notes	Drill Holes
			Order #	Notes	Drill Holes		
CHEV/GMC							
88-94	1500 / 2500 (All)	8'	39116	3		s/o C4201	4,5 4
91-94	3500 (All)	8'	39116		4	s/o C4201	4,5 4
95-98	1500 / 2500 (All)	8'	39116		4	s/o C4201	4,5 4
95-00	3500 (All)	8'	39116		4	s/o C4201	4,5 4
99-07	1500/2500 LD Classic	8'	39117		0	s/o C4203	4,5 4
99-07	1500/2500 LD Classic	6.5'	39117		0	s/o C4203	4,5 4
01-07	1500/2500/3500 HD	8'	30253	10	0	s/o C4203	4,5 4
01-07	1500/2500/3500 HD	6.5'	30254	10	0	s/o C4203	4,5 4
07-10	2500/3500 New Body	8'	30253		0	s/o C4203	4,5 4
07-10	2500/3500 New Body	6.5'	30254		0	s/o C4203	4,5 4
07-10	1500 New Body Std.	6.5'	s/o C2208		0		N/A
07-09	1500 New Body Std.	8'	s/o C2206		0		N/A
07-10	1500 New Body Ext.	6.5'	30841	*	0		N/A
07-10	1500 New Body Ext.	8'	30841	*	0		N/A
04-10	1500 (CrewCab)	5.5'	s/o C2211		0		N/A
2010	1500 New Body Std.	8'	31723		0		N/A
TOYOTA							
05-10	Tacoma (All)	ALL	s/o T2303		0		N/A
00-06	Tundra Ext.	6.5'	s/o T2301		0		N/A
03-06	Tundra,w/HD tow pkg	6.5'	s/o T2301		0		N/A
05-06	Tundra,w/Std tow pkg	8'	s/o T2302		0		N/A
05-06	Tundra,w/HD tow pkg	8'	s/o T2302		0		N/A
07-10	Tundra (All)	6.5'	30842		0		N/A
07-10	Tundra (All)	8'	s/o T2305		0		N/A
07-10	Tundra (CrewMax)	5.5' (4WD)	s/o T2307		0		N/A
NISSAN							
05-10	Frontier (King/Crew)	6'	s/o N2409		0		N/A
04-09	Titan, King Cab, 2dr	6.5'	30096		0		N/A
04-10	Titan, Crew Cab, 4dr	5.5'	s/o N2401		0		N/A
2008	Titan, King Cab, 2dr	8'	s/o N2405		0		N/A
2008	Titan, Crew Cab, 4dr	7'	s/o N2406		0		N/A

FOOTNOTES FOR APPLICATION CHART

- (1) SuperHitch Magnum requires the use of R3504.
- (2) Drilling required into **spring hanger** bracket, not into frame of vehicle.
- (3) Drilling may be required.
- (4) May require modification of running board bracket.
- (5) Additional labor required for installation.
- (6) Front tie down available only in adjustable style only.
- (7) 1997 F150 & 97-03 light duty F250 models, use 97-03 F150/F250 LD application.
- (8) **Will also work on trucks without receiver hitch.**
- (9) HD tow pack attaches to side of frame, standard tow pack attaches to bottom of frame only.
- (10) 1500 HD vehicle owners please call 800.246.8132 to verify your correct application fit.
- (*) Only fits the front of a crew cab with the 5.5' bed.

TorkLift True Frame Mounted Camper Tiedowns

TorkLift's unique patented design incorporates four independent tiedown points that bolt directly to the trucks heavy-duty frame (no belly or cross bars). TorkLift tiedowns are engineered to fit tight and secure to your trucks frame with no compromise in ground clearance. Most applications are no drill making installation quick and easy.



CAMPER TIE-DOWNS

RV ACCESSORIES



In Section M:	Starter Kits	Vehicle Items	Window & Door	Interior Accessories	Mats	Steps	Camper Tie Downs	Wheel Chocks	Ladders	Carriers	Winches	Levelers	Jacks
---------------	--------------	---------------	---------------	----------------------	------	-------	------------------	--------------	---------	----------	---------	----------	-------

Frame Mounted Camper Tie Downs Application Guide

Step 2

CHOOSE YOUR REAR TIE DOWNS
 Does the vehicle have a rear receiver hitch that is:

Factory
SuperHitch
Aftermarket

Step 3

Year	Make/Model	Bed Length	FACTORY				AFTERMARKET				
			Order #	Notes	Notes	Notes	Order #	Notes	Notes	Drill Holes	
CHEV/GMC											
88-94	1500 / 2500 (All)	8'	39148	15		30771	18		39114	12	8
91-94	3500 (All)	8'	39148	15		30771	18		39114	12	8
95-98	1500 / 2500 (All)	8'	39149	15		30771	18		39114	12	8
95-00	3500 (All)	8'	39149	15		30771	18		39114	12	8
99-07	1500/2500 LD Classic	8'	39118	8		30771	18		39114	12	8
99-07	1500/2500 LD Classic	6.5'	39151	8					39114	12	8
01-07	HD 1500/2500/3500 Classic (All)	8'	39120	8		30771	18		39112	12	8
01-07	HD 1500/2500/3500 Classic (All)	6.5'	39153	8		30771	18		39112	12	8
07-09	2500/3500 New Body	8'	30763			30771	18		39112	12	8
07-09	2500/3500 New Body	6.5'	30763			30770			39112	12	8
07-09	1500 New Body Std.	6.5'	39151	8					39114	12	8
07-09	1500 New Body Std.	8'	39118	8					39114	12	8
07-09	1500 New Body Ext.	6.5'	39151	8					39114	12	8
07-09	1500 New Body Ext.	8'	39118	8					39114	12	8
04-09	1500 (CrewCab)	5.5'	39151	8					39114	12	8
2010	1500 New Body Std.	8'	39118	8					39114	12	8
2011	2500/3500 HD (CC)	8'	s/o C3212			s/o C3212			39114	12	8
TOYOTA											
05-10	Tacoma (All)(4WD)	ALL	s/o T3303						39114	12	8
00-06	Tundra w/std TP, Ext.	6.5'	s/o T3301	8,9					39114	12	8
03-06	Tundra, w/HD tow pkg (All)	6.5'	s/o T3302	9					39114	12	8
05-06	Tundra w/std TP, (All)	8'	s/o T3301	8,9					39114	12	8
05-06	Tundra, w/HD tow pkg	8'	s/o T3302	9					39114	12	8
07-10	Tundra (All)	6.5'	30843						39114	12	8
07-10	Tundra (All)	8'	30843						39114	12	8
07-10	Tundra (CrewMax)	5.5'(4WD)	30843						39114	12	8
NISSAN											
05-10	Frontier (King/Crew)	6'	s/o N3403	13	0				39114	12	8
04-09	Titan, King Cab, 2dr	6.5'	30098	9					39114	12	8
04-10	Titan, Crew Cab, 4dr	5.5'	30098	9					39114	12	8
2008	Titan, King Cab, 2dr	8'	30098	9					39114	12	8
2008	Titan, Crew Cab, 4dr	7'	30098	9					39114	12	8

CHOOSE YOUR TURNBUCKLES:
See page 376

Basic Springload Kit

Spring Load XL

Denotes limited supply!

The Original FASTGUN

REAR
TIEDOWNS

FOOTNOTES FOR APPLICATION CHART

(11) Will work with aftermarket hitches that **do not** have side-plates.
 (12) Will **only** work with aftermarket hitches that have side-plates (4" x 4" mounting footprint required).
 (13) Will only work on truck without hitch.
 (14) On dually applications rear camper anchor point location may require the use of A7004.
 (15) Requires factory installed receiver w/open crosstube.
 (17) D1101M requires R3504 / D1102M requires R3503.
 (18) Will not work on welded single piece super hitches.

(H) Indicates that drilling will be required, and the number following designates the total number of holes drilled for installation (example: H4 = 4 holes drilled).

Don't settle for almost frame mounted... Make sure that your Truck Camper is safe and secure with TorqLift True Frame Mounted Camper Tiedowns.

For Fast and Friendly Tech Support
1-800-246-8132



TORKLIFT STABLE LOAD

Put your Leaf Springs Back to Work

Specifically engineered for For all Towing and Hauling Applications on 85-08 Ford Super Duty and 94-08 Dodge Heavy Duty trucks. Torklift's large Stable Load Spring Pads replace the smaller, inefficient factory rubber bump stop pads, putting the factory springs back to work stabilizing the suspension and the truck's load.

Kit includes: 4 Stable Loads

Features: • Lifetime Warranty • Quick No-Drill Installation • Improved handling • Lower Air Spring pressure • Angled design maximizes spring contact surface • Anti-rotation Key Tabs.



30783 Stable Load Spring Pads, set/4 #A7200 4



TORKLIFT BASIC SPRINGLOAD KIT

- Lifetime Warranty • Spring Tension Indicators
- Kit includes 2 Springload Units & 2 Heavy-Duty Forged Steel Turnbuckles



SPRING-LOAD UNITS - Add to any tie down kit to make it spring-loaded

Includes	2 Spring loaded units with 2 heavy duty turnbuckles	39122	1
----------	---	--------------	---



100% Stainless Steel



TORKLIFT SPRINGLOAD XL

Designed exclusively for all frame-mounted tiedowns. The 100% Stainless Steel Springload XL turnbuckle gives a custom clean look and an inexpensive upgrade alternative to the basic springload and chain system. The Springload XL incorporates the Lifetime Guarantee FastGun internal springs and Spring Tension Indicators. Sold in sets of two with a reach of 28" to 44".

39579 Long Springloaded Turnbuckle #S9050 1



TORKLIFT ANCHOR GUARD

Our 100% Stainless Steel bed mounted tiedown turnbuckle kits are backed with a Lifetime Warranty and come complete with our exclusive Spring Tension Indicators. Each kit includes four turnbuckles; two front spring loaded and two rear cushioned. Anchor Guard: • Best Warranty. • Best Value. • Best Choice.

30248 Anchor Guard, 100% Stainless Steel #S9013 1

TORKLIFT INTERNATIONAL FAST GUN



- Long Range:
- 39903** Stainless Grey #S9522 1
 - 39904** Stainless White #S9523 1
 - 30245** Stainless Polished #S9526 1
 - 4 Pack Keyed Alike Lock Set: **30047** Lock Set (4/Pack) #S9500 1

- 100% Tool Free;
- 100% Lockable;
- 100% Stainless Steel;
- Lifetime Warranty;
- Spring Tension Indicators;
- Fastest on the market.

For front & rear frame mounted and rear bumper mounted tie downs, 25'- 43' reach. Kit Includes: 2 Fastgun Turnbuckles.

Works only with bed mounted front tie downs, 14.5' - 21.5' reach. Kit includes: 2 fastgunturnbuckles.

- .45": **39902** LS US only Stainless White #S9521 1
- 30244** Stainless Polished #S9527 1



Tech Support: 1-800-246-8132



LEISURE TIME WHEEL CHOCK

These large wheel chocks are 44% larger and 24% stronger than regular wheel chocks. They measure 4 1/2" H x 8" W x 10 1/2" L.

38728 Large Chock #14079 g

WHEEL CHOCKS • LEVELERS

RV ACCESSORIES

M

In Section M: Starter Kits Vehicle Items Window & Door Interior Accessories Mats Steps Camper Tie Downs Wheel Chocks Ladders Carriers Winches Levelers Jacks



HUSKY WHEEL CHOCKS



- Cross Ribbed
- High-Impact Plastic
- Bright Color
- 7 1/4" L x 5" W x 4 1/4" H

Husky Wheel Chocks:

95036 6 per Box #95036 12

38511 2 per Clam Shell #38511 16

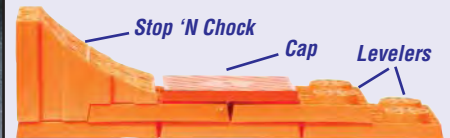

70359

LYNX LEVELERS



- Multi-Ribbed Design
- High-Impact Plastic
- Built-In Sure Grip

MAC WHEEL CHOCK

Multi-ribbed reinforcement chock design features the convenience of a built-in sure grip handle. Made of high-impact plastic, these chocks provide superior strength, safety and stability to your parked travel trailer or boat trailer. Dimensions: 8 1/16" L x 3 3/8" W x 4" H. This product has great appeal in both the Marine and RV markets. Black plastic.

34714 Wheel Chock #34714 30



VALTERRA WHEEL CHOCK

- Prevents your tire from rolling or sliding.
- Has ribbed surface for better grip.
- Nylon cord allows you to easily remove the chock when finished.

39323 Wheel Chock #A10-0908 14



77433

LYNX RECREATIONAL VEHICLE LEVELING KIT

Modular designed levelers not only configure to fit any leveling function, but they also withstand tremendous weight. To use: simply set them into a pyramid shape to the desired height that the RV needs to be raised and drive onto the stack. The levelers can also be used as a support base for other stabilizing equipment. Use under single and dual wheels, under tandem axles and under jacks. 8 1/2" x 8 1/2" with 1 1/2" thickness to give 1" lift. The 10 pack comes in an easy to store nylon bag and weighs less than ten pounds; the 4 pack weighs 3 lbs.

Lynx Levelers:

70359 4 Pack #00016 16

77433 Set of 10 Levelers with Nylon Bag #00015 8

LYNX STOP 'N CHOCK

LEVELING YOUR RV HAS NEVER BEEN EASIER

The only self-positioning guide. Now you'll hit the top of the stack every time. The perfect accessory for your original Lynx Levelers. Just place the Stop 'N Chock on a stack of Lynx Levelers, but the stack up to the wheels, slowly idle your RV to the top of the stack until you Stop 'n Chock. It's that easy! • Strong and durable. • Easy to clean. • Safe and easy to use. • 8.5" x 8.5" x 6".

74947 Lynx Stop 'N Chock, Each #00018 16

77545 Lynx Stop 'N Chock, Bx/2 #00018-2PK 8

LYNX LEVELER CAP

GIVES YOU A FULL FLAT SURFACE ON TOP OF YOUR ORIGINAL LYNX LEVELERS

The cap is designed to provide a flat surface to accommodate the many styles of stabilizing pads found on the market today, and can also be used to provide a flat surface while using the Levelers under the wheels. The unique interlocking design of LynxCap™ means it will not increase the stack height and ensures a secure fit on your original Lynx Levelers. Comprehensive 3-yr. mfr. warranty.

86306 Lynx Leveler Cap Pk/4 #00019 8

STOP 'N CHOCK

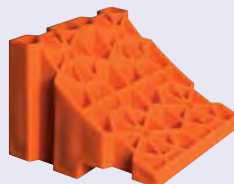

SEE RUNNING GEAR SECTION "O" FOR OTHER TIRE & WHEEL ACCESSORIES



86849 fully opened

86849 fully closed

Enhanced Version Now Features:

- E-Z grip handle creates better leverage.
- Super grip louvers for maximum grip

CHOCK-N-LOCK DELUXE ULTRA CHOCKS FOR TANDEM AXLES

Enjoy greater comfort with **Chock-N-Lock**. Patented device locks in stability to eliminate front to back movement when you're in your RV.



Chock-N-Lock locks the two wheels of the tandem trailer to render them motionless. When engaged, each tire works against the other. **Chock-N-Lock** is effective on most trailers regardless of wheel spacing or ground surface. A cam and scissors is activated, assuring a total lock. It provides stability on any ground, loose dirt, gravel or incline. Don't stand still for RV rock. Replace your wooden blocks, bricks and other chocks with **Chock-N-Lock**. Your trailer won't move unless you want it to.

Features: • Simple one-step operation—takes just seconds to install. • Easy to operate by just one person—weighs only 5 lbs. • Corrosion-resistant zinc plated. • Heavy gauge, all steel construction for strength and durability. • May be padlocked for security. • Minimal storage space required—2-1/2" x 4" x 10". • Adjusts from 2" to 6" to accommodate wheel spacings on different trailers. • One-yr. limited mfr. warranty.

86849 Chock-N-Lock Ultra Deluxe Chock, Each #21-001060 10

86850 Chock-N-Lock Ultra Deluxe Chocks, 2/Pk. #21-001070 5



VALTERRA BIG CHOCK WHEEL CHOCK

Heavy duty wheel chock keeps RVs in place. Includes rubber foot to enhance grip and nylon cord for easy removal. 9.5" L x 8.5" W x 4.5" H.

30729 Big Chock Wheel Chock #A10-0914 6



UNIVERSAL VAN LADDER AND DECK RAIL

Universal Van Ladder is of round aluminum tubing with elliptical, serrated steps. It is complete, ready to mount, even to the pre-attached brackets (but mounting screws are not included). Ladder measures 49 1/2" L x 12"W. Deck rails complement the ladder and feature a turned down angle to meet and attach to the roof in front. This avoids "catching" on limbs or wires. Rails are 48" L x 52" W assembled.

70356 4-Step Ladder Only (without mounting screws) Note: Does not fit Ford vans 92 and up #400-4S 1

70357 LS US only Deck Rails Only #148BTR 2/4-2 1

1 product, 3 solutions!

VALTERRA EZ LEVELER & JACK PAD

- Multi-use – leveler, jack or tongue wheel support.
- EZ Leveler – stacks to required height.
- Strong – holds up to 40,000 lbs.
- Adaptable – works on hard or soft ground.
- Convenient – snaps together for carrying & storage.



EZ Leveler & Jack Pad:

30726 Set of 4 #A10-0916 6

30727 Set of 10 #A10-0918 4



VALTERRA STACKERS' CHOCK

Designed to work with Valterra's "STACKERS" RV leveling block system. Place in position, drive onto the stackers and the chock stops the RV wheel at the top of the stack. It's that simple and makes leveling a one person job! The STACKERS' CHOCK also includes a built-in handle for secure nesting onto the STACKERS leveling blocks as well as easy carrying.

87575 Stacker's Chock #A10-0922 6



VALTERRA STACKERS

Pack of 10. Sold in a bag.

87574 Stackers, Pk/10 #A10-0920 4

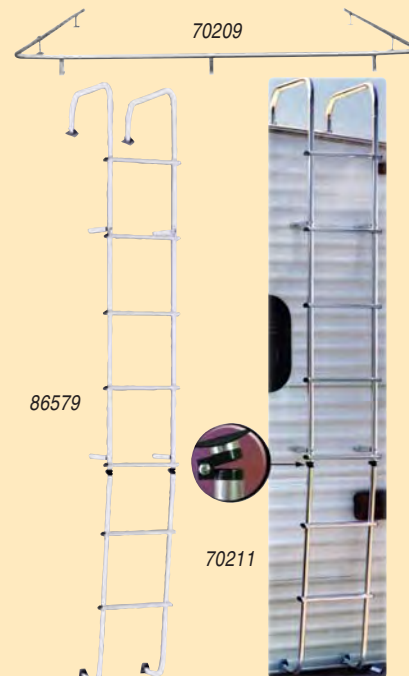

70209

86579

70211

MOTORHOME RACK AND LADDER

Both rack and ladder are made of Brite-dipped anodized high-tensile strength aluminum. Tubing is heavy wall 1" diameter, and stand-offs are extruded. Universal rack is 80" wide, and can be made to fit smaller units by cutting a section out of the back rail. Universal Ladder (97 1/2") will fit any motorhome, camper, 5th wheeler or trailer. Hinged and adjustable to conform to any vehicle contour. Mounting hardware included.

Universal Motorhome Rack only with stanchions:

70209 Silver #UR-101 1

86578 White #URW-101 1

Universal Motorhome Ladder only

70211 Silver #UL-100 1

86579 White #ULW-100 1

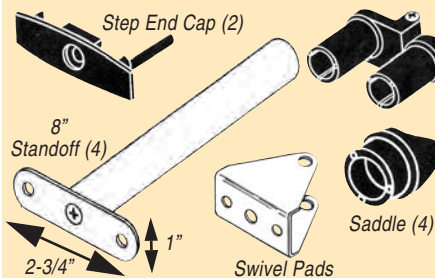

NEW! STANDOFF PACKAGE FOR LADDERS (MODEL #UL-100)

Includes: • 8" Standoff Tubes (End of 2-3/4" x 1") (4); Attaches ladder to coach. • Saddles (4); Between standoff and ladder bow. • Oval Pads (4); For mounting top and bottom ladder. • Step End Caps (2) and all screws needed for mounting.

87564 Standoff Parts Package for UL-100 #CI-54 1



TOPLINE CHAIR RACK LADDER MOUNTED

- Fits any RV ladder, any make, any model, any year. • Unique "Docking System".
- Holds up to 6 chairs securely.
- Hooks on without use of tools. • Easy on, easy off, 5 second installation. • Engineered "Tie-Down System". • All straps included.

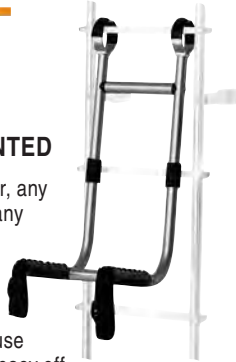

77085 Chair Rack, Fits elliptical/flat step ladders #CR1300

TOPLINE BUNK LADDERS



- High strength 6063-T6 aluminum alloy, supports up to 300 pounds. • No external fastener visible. Beautiful, finished appearance. No screw heads, etc.
- Anodized satin finish on rails and steps. • Steps are padded to prevent slipping, providing a warm, cushioned feel.
- Simple rugged construction.
- All parts finished to avoid snagging clothing, and eliminate any physical danger of cutting or scratching.
- No slip, no mar bumper pads on bottom of the ladder rails.



Padded step prevents slipping, warm and cushioned to bare feet.



Hook 1.5" opening black polyester powdercoated finished steel.

Docking System:
 • Retainers mounted to bunk rail. • Ladder assembled to retainer as follows: 1. Ladder held parallel to ground. 2. Ladder joins retainer. 3. Ladder rotates to ground.

1-1/2" Hook Style:

74942 60" Ladder #BL200-05 ₁

74944 66" Ladder #BL200-06 ₁

Docking System:

79119 60" Ladder #BL200-07 ₁

79154 66" Ladder #BL200-08 ₁

SportRack®



HITCH PLATFORM SYSTEM 2EZ

- Easy to install, use and store. Recommended for 1-1/4" and 2" receiver.
- Carries up to 2 bikes.
- Rubberized hooks to protect bike finish.
- High-grade (14 gauge) powder-coated steel. Fits all bike frames and sizes.
- Center post tilts away for easy rear vehicle access.



76096 2EZ Bike Carrier #A30901 ₁

ELITE UPRIGHT BICYCLE CARRIER

- Universal bicycle carrier.
- Fits most other load carrier systems on the market.
- Fits perfectly on our Tent Trailer Rack #86309.
- Suitable for all bicycle models: race, mountain and touring.
- Made of top-quality steel tubing treated with anti-rust paint.
- Telescopic rail.
- Anti-theft lock provided.



86310 Elite Upright Bicycle Carrier #A882 ₆

TENT TRAILER RACK

Rail Kit Included.

#86309 SPECIFICATIONS

- Material: Steel.
- Finish: Powder-coated.
- Color: Black.
- Length: From 80" (203cm) to 86" (218 cm).

Take full advantage of your camping trips by carrying bikes, kayaks, canoes, basket racks & small boats! With an attractive design and finish, the SportRack "Trailer Tent Rack" looks great on any folding camping trailers. Can be adjusted in length and installs easily and quickly on most folding camping trailers.

86309 Tent Trailer Rack #A21020 ₁



DUTTON LAINSON TIPPERLATCH

For use on tilt-bed medium and light-duty trailers such as PWC, snowmobile & utility. The automatic latch holds the tilt bed securely in place. The spring loaded non-pinching latch is engineered for easy release. Zinc plated TUFFPLATE® finish.



78670 Tipperlatch #13353 ₁



ULTRA-FAB PRODUCTS
CARGO CARRIERS

NEW!

87569 installed



87570 installed

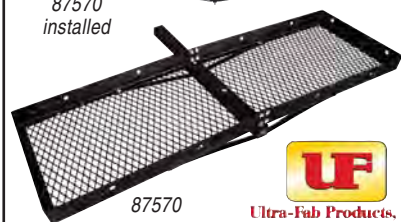

87570



Ultra-Fab Products, Inc.

- Rugged Steel construction. • Powder coated for years of durability. • Metal mesh platform eliminates standing water. • Convenient tie-down utility holes. • Fits 2-inch receiver hitch. • 1-yr. warranty.

Cargo Carrier (Weight, Capacity):

87569 XL Cargo Carrier, 23.25" x 60", (39 lbs, 500 lbs) #48-979025 1

87570 Cargo Carrier, 19.25" x 60", (36 lbs, 500 lbs) #48-979029 1



NEW!

BIKE RACK ACCESSORY FOR HAULER

- Rugged steel construction. • Powder coated for years of durability. • Holds up to 3 bikes. • Convenient tie-down strap included. • Lightweight for easy mounting. • Installs easily in just minutes to cargo carrier (Sold separately). • Lifetime warranty.

87571 Bike Rack Accessory for Hauler #48-979030 1



Fits any vehicle

Bikes never touch each other.



TOPLINE LADDER-MOUNT BIKE RACK

Unique "Docking System" mounts in seconds.

- Fits any RV ladder, any make, any model, any year. • Unique "Docking System" hooks on without use of tools. • Holds two bikes securely. • Easy on... easy off... • Engineered "Tie-Down" system. • All straps and cushions included. • Bikes protected from damage. • Anodized to resist corrosion. • Weighs only 2.1 pounds. • No assembly required. • Stores easily.

77084 Bike Rack (Fits Flat/Elliptical-Step Ladders) #BR1200 2

Master Lock

MASTER LOCK SPARE TIRE LOCK



Prevent theft of spare tire and wheel. Heavy-duty lock fits bolt sizes up to 1/2" diameter. Bright chrome plated.

30097 Spare Tire Lock #262DAT 24



SPORTRACK HITCH-MOUNTED BASKET CARGO CARRIER

SportRack

NOTE: Hitch must have a minimum Class III/IV rating. Total weight of carrier and cargo not to exceed 500 lbs.

- Basket dimensions 60" x 20" x 6". • Made to fit in 2" receiver hitch. • Heavy-duty all-steel tubular construction. • 2-piece bolt-together unit. • Frame made with 5/8" dia. tubular steel. • Expanded steel mesh floor. • Formed 2" square extension bar is reversible to be used in drop or rise position. • Sides are 6" H to keep cargo secure and in place. • Black powder-coat finish is weather-resistant.

86424 Hitch Basket Fold-Away #A30850 1



STROMBERG CARLSON TIRE CARRIER, TR SERIES

- Fits on 4" square bumpers. • Design for Travel Trailer and Fifth Wheel Spares. • Heavy Duty Simple Construction. • Includes all parts and hardware to attach your tire to the carrier and the carrier to your 4" square bumper. • Deluxe four color black & gold packaging.

UNIVERSAL RIGID TIRE CARRIER

87237 Tire Carrier, Rigid column design #TR-1 1

UNIVERSAL FOLDING TIRE CARRIER

Folding column to access rear compartments.

87238 Tire Carrier, Folding #TR-2 1

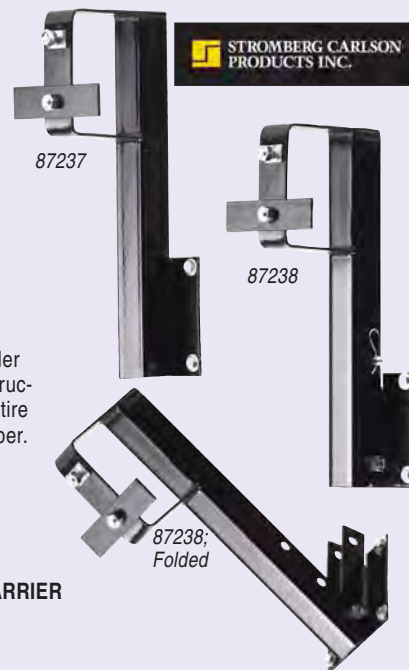

STROMBERG CARLSON PRODUCTS INC.

87237

87238

87238; Folded

SportRack® HITCH-N-DRIVE STANDARD SERIES



The STANDARD SERIES has a user-friendly bicycle attachment.

- Protective rubber extrusions help protect bicycles.
- This system is designed to handle bikes with oversize upper bar (2-1/2" or less in diameter).
- Can carry race, mountain or touring bicycles.
- Locking kit not included.

Part #	Description	Mount	Holds # Bikes	Lock?	Max Wt.	Position	Price
86307	Std. 3-Bike Rack-Bx/1	Fixed Mount	3	No	132 lb.	Fixed	
86311	Std. 3-Bike Rack-Bx/1	1 1/4" & 2"	3	No	132 lb.	Fold-down	
86305	Std. 4-Bike Rack-Bx/1	1 1/4" & 2"	4	No	180 lb.	Fold-down	

**SEE PAGE 217
FOR BIKE COVERS**

HITCH-N-DRIVE - 700 DELUXE SERIES

The DELUXE SERIES has adjustable, independent clamps to securely carry up to five bikes. Lock kit included. • This system is designed to handle bikes with oversize bar (2-1/2" or less in diameter) and/or angled-frame bikes. • Protective rubber extrusions help protect bicycles.

Part #	Description	Mount	Holds # Bikes	Lock?	Max Wt.	Position	Price
86401	Del. 5-Bike Rack-Bx/1	2"	5	Included	225 lb.	Fold-down	

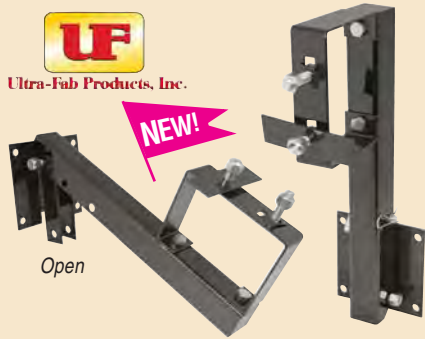

ULTRA-FAB PRODUCTS UNIVERSAL TIRE CARRIER

- Retaining bolt with clevis pin for adjustable, solid retaining bolt for rigid.
- Bolts to 4-in. box bumpers.
- Fits C style truck bumpers.
- Powder coated and rust resistant for longer life.
- Heavy-duty construction for greater strength.
- Easy to install, bolts on in minutes.
- Fits 5, 6 and 8 lug Kelsey Hayes type wheels and Fayette type travel trailer wheels.
- Lifetime warranty.

87565 Universal Tire Carrier
#15-954730 **1**



SUSPENSION PRO SPARE AND DOLLY BRACKET

Fits either 4 or 5 hole rim for 8", 9" and 12" tires. Drilled with padlock hole in main shaft. Serves as a revolving spare tire carrier and dolly wheel when trailer is removed from car. Provides full tire tread width when used as a dolly wheel. Particularly effective on soft ground. Black powder-coated finish. Fit 3" x 3" and 3" x 4" square tongues. Wheel and tire not included. Made in USA.

70463 Spare And Dolly Bracket
#22144 6221 **1**

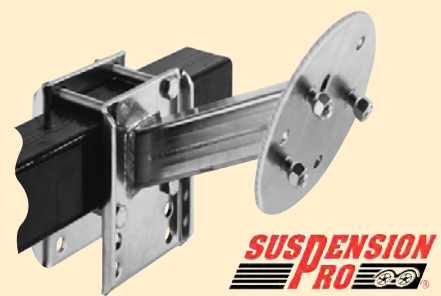

SUSPENSION PRO EXTRA OFFSET SPARE TIRE CARRIER

Heavy-duty bracket extends the spare tire at an angle to avoid damage or marring of boat finish. Zinc-plated TUFFPLATE® finish. Fits wheel sizes from 13" to 15", 5 hole rims. Fits trailer tongues 2" or 3" wide, up to 5" high. Made in USA.

78667 Offset Spare Tire Carrier, Boxed
#22145 **1**

All Suspension Pro winches are engineered to offer many distinct advantages not available on other winch lines. A wide variety of hand winches are available for most hand winch applications. You can choose from standard ratchet winches, in either single or two-speed models. For specific applications, you may need self-locking brake winches or worm gear winches which are also in the Suspension Pro line. See winch selection guidelines below.



WINCHES

% Incline	Multiply By:
Level Surface	10.0
5(3°)	6.67
10(6°)	5.02
20(11°)	3.40
30(17°)	2.61
50(26°)	1.86
70(35°)	1.53
100(45°)	1.29

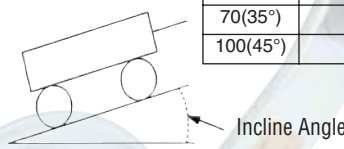

Guide To Hand Winch Selection

Rolling Load Capacity

To calculate the rolling load capacity of a winch (the amount of load that can be pulled up an incline) multiply the winch capacity by the factor shown in the chart at the right. The multiplication factor shown includes a 10% rolling friction factor. Note: 5% incline is a 1/2' rise in 10'.

Boat Weight To Winch Capacity Ratio

A commonly used ratio of boat size to winch capacity is 2 to 1 (Example: a 2200 lb. boat requires 1100 lb. winch). However, there are many factors to consider in selecting the proper size winch which are beyond the control of the winch manufacturer. For example, the ratio can sometimes be stretched to 3 to 1 when using a trailer equipped with good quality free-turning rollers maintained in excellent condition and most commonly used on ramps where the boat floats most of the way onto the trailer. The ratio should be reduced to as much as 1 to 1 on trailers using wooden bunks with no self-alignment capabilities, most frequently used on boat ramps requiring that the boat be winched a long way onto the trailer. Note that pontoon boat trailers and other special designs require special consideration to winch capacity selection.

General Winch Selection Guidelines

Because the high forces generated when using a winch create potential safety hazards, careful consideration should be given to the winch selection process. Safety should be a primary concern and questions such as what winch features are required for the application, what will be the experience level of the user, and what harsh environmental conditions will exist, should all be answered. More specifically, an important first question should be, "Does the application require the free-wheeling feature (the ability to pull cable freely from the drum to attach it to the load) available in ratchet-type winches?" If not, a self-locking type winch (brake winch or worm gear winch) should be used. Generally, ratchet-type winches are not recommended for lifting applications, and their use is discouraged in other than horizontal or incline pulling operations requiring a free-wheeling feature.

The experience or skill of the intended user is also important. For example, self-locking type winches should generally be selected for rental equipment, even if lack of a free-wheeling feature will make the operation slower or more cumbersome. This is because rental equipment will frequently be used by inexperienced operators unfamiliar with the safe use of the product, and self-locking winches reduce the skill and understanding necessary to operate a winch safely.

If the winch is likely to be used in a harsh environment, including such things as salt water, a potential for damage or abuse of the winch, or the likelihood of little or no periodic maintenance, then this should be factored into the winch selection. Possibly a larger size winch should be selected, or guards on the product using the winch should be provided to protect the winch from damage or abuse.

It is sometimes difficult to determine the amount of load being pulled with a winch. All Suspension Pro hand winches are designed to pull their rated capacity with a force on the handle in the approximate range of 35 to 55 pounds. This means that the winch should be able to be cranked easily with one hand. If not, it is probably overloaded.

Suspension Pro winches are not designed to be used as hoists for lifting, supporting, or transporting people, or for loads over areas where people could be present. Suspension Pro winches are built to high quality standards, but do not include the features necessary to make them appropriate for moving of humans or overhead hoisting and lifting applications.



WINCHES & ACCESSORIES • TIRE CARRIERS

RV ACCESSORIES



In Section M: Starter Kits Vehicle Items Window & Door Interior Accessories Mats Steps Camper Tie Downs Wheel Chocks Ladders Carriers Winches Levelers Jacks



All Suspension Pro Winches are made in USA and feature a 5-year warranty.

Item #	Rated Capacity (1)	Drum Hub Dia.	Gear Ratio	Handle Length	Max Mech. Adv.	Replacement Handle #	Reversible Ratchet	2-Speed Operation	Max. Drum Capacity (2)
Standard Duty - Ratchet Hand Winches									
70458	400 lbs./181kg	5/8"	1:1	7"	18	—	—	—	1/8" x 87'
70443	600 lbs./272kg	5/8"	3.2:1	7"	57	72132	—	—	5/32" x 61'
70452	900 lbs./409kg	5/8"	3.2:1	7"	55	72132	—	—	
70454	1100 lbs./499kg	7/8"	3.7:1	7"	49	72132	—	—	3/16" x 79'
70444	1300 lbs./590kg	7/8"	4.4:1	7"	56	72132	—	—	
Medium Duty - Ratchet Hand Winches									
70456	1400 lbs./636kg	7/8"	4.4:1	9-1/2"	74	—	•	—	1/4" x 40'
70445	1600 lbs./726kg	1-1/8"	5.4:1	9-1/2"	75	72134	•	—	1/4" x 58'
70446	1800 lbs./817kg	1-1/8"	5.4:1	9-1/2"	73	72134	•	—	9/32" x 58'
Heavy Duty - Ratchet Hand Winches									
70447	2000 lbs./908kg	1-1/8"	12.4:1 / 5.4:1	9-1/2"	168	72135	•	•	9/32" x 58'
70448	2500 lbs./1135kg	1-1/8"	17.3:1 / 5.4:1	9-1/2"	229	72135	•	•	5/16" x 47'

(1) Capacity based on direct line pull on the third layer of line on the drum. Capacity is reduced as the line builds up on the drum.
 (2) Drum capacity shown is based on cable size listed. (Cable not included.)

REPLACEMENT HANDLES FOR ABOVE WINCHES

Item #	Description	Item #	Description	Item #	Description
72132	Handle	72134	Handle	72135	Handle

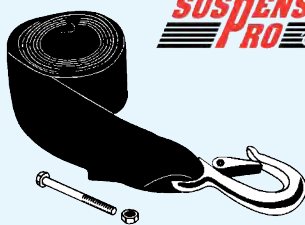

SUSPENSION PRO WINCH STRAPS

Durable polyester web strap makes winching your boat even easier. 2" width fits hand winches up to 2600 lbs. capacity, and winds on smoothly and evenly. Safer and more attractive than cable or rope. Breaking strength 4000 lbs. Forged steel hook with tensile strength of 7500 lbs. Carded with two mounting bolts: one to fit smaller winches and one for larger sizes.

Winch Strap with Hook:

- 70534 15' #70534 12
- 70535 20' #70535 12
- 70536 25' #70536 12

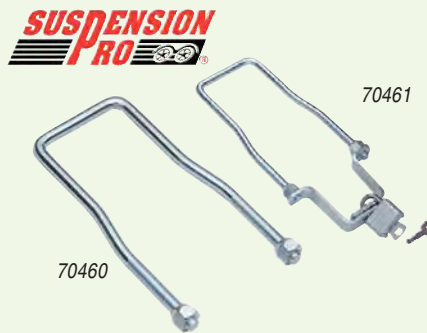

SUSPENSION PRO SPARE TIRE CARRIER

Suspension Pro Spare tire carrier with or without locking bracket and padlock. Extra length allows the handling of extra wide tires or wider tongues of custom-built trailers. Fits either 4 or 5 hole rims. Zinc-plated TUFFPLATE® finish.

Spare Tire Carrier:

- 70460 Without Padlock #22128 6
- 70461 With Padlock #22136 6

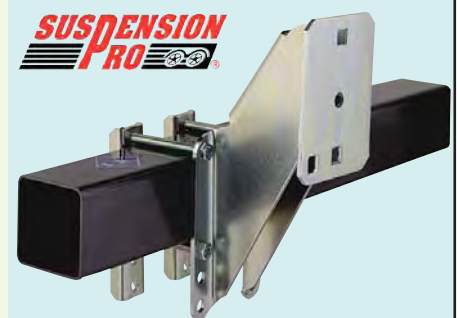

SUSPENSION PRO TRAILER SPARE TIRE CARRIER

This carrier extends the spare tire up and away from trailer and boat. Heavy-duty steel construction that is zinc plated with TUFFPLATE®. Fits wheel sizes from 9" to 14". Fits either 4 or 5 hole rim and trailer tongues up to 3" x 5". Maximum tire size 14". Complete with mounting hardware. Made in USA.

- 70459 Tire Carrier #22122 6