

ALL-NEW 2017 SUPER DUTY



Introducing an all-new F-Series Super Duty. The 2017 F-250, F-350, and the massive F-450. We set the standard in truck capability. Now we've raised it even higher. This tough-as-nails workhorse is loaded with material innovation and advanced technology. Rust can't touch its all-new high-strength, military-grade, aluminum alloy body and cargo box.¹ Its all-new, fully boxed, high-strength steel ladder frame is the strongest Super Duty pickup frame. Ever. Together, they form the foundation for

THE TOUGHEST, SMARTEST, MOST CAPABLE SUPER DUTY EVER.



2017 Super Duty® | ford.com

F-250 LARIAT Crew Cab 4x4 in Magnetic with Chrome Package and available equipment. ¹6000-series aluminum alloy.

Vehicles throughout this PDF may be shown with optional and aftermarket upfit equipment.





It's astounding what an F-Series Super Duty will haul over its lifetime. Cinder block. Stumps. Pipe. Tools. Machinery. Landscaping material. Generators. 5th-wheel/gooseneck trailers. So we've made the cargo box of the all-new 2017 Super Duty even more capable. It's the first and only one in its class¹ made from high-strength, military-grade, aluminum alloys. To handle the increased loading requirements and enhanced capability of a Super Duty workload, we re-engineered the cargo box and upgraded its panel thickness. It does not rust. It's more dent- and ding-resistant. Simply put, it is

THE TOUGHEST SUPER DUTY BODY EVER.

Use of this advanced material saved weight as well, so we reinvested those savings directly into upgrading the essential components that work the hardest – the frame, axles, leaf springs, transfer case, driveline and trailer hitches. With a stronger frame, tougher body and upgraded componentry, the 2017 Super Duty tows more, hauls more, and is more capable than ever – while weighing up to 350 pounds less than before. This is the Future of Tough.



THE STRONGEST SUPER DUTY FRAME EVER.

Super Duty demands a foundation built for extremes. This all-new, fully boxed ladder frame – made of 95% high-strength steel – is engineered to be up to the task. With 6 times more high-strength steel than the previous generation, it's up to 24 times stiffer – helping to produce the best ride and steering of any Super Duty ever. That's just the kind of stability you need when you're towing a best-in-class 32,500 lbs. of heavy-duty machinery behind you.¹

Through-welded, closed-section crossmembers, used on Super Duty for the first time, help increase torsional stiffness. Frame mid-rails are 1.5" taller for added stiffness. And an e-coat paint process encases all that strength for extreme durability and corrosion protection.

24X STIFFER

12 MILLION MILES OF TESTING

We tortured it. In the engine lab, on the proving grounds, and working in the real world. Our dedicated team of truck engineers ran it with maximum trailer weights. Up and down steep grades. Then up and down again. In stifling heat above 100°F. And in subzero cold. This all-new 2017 Super Duty is engineered for extremes.

Its robust new cargo box endured extensive strength and durability testing. First, with body structure engineers running it through countless hours of supercomputer simulations. Then, while driving prototype vehicles over brutal road surfaces at maximum payload limits. The cargo box and upgraded driveline took the abuse, run after run. Before the first truck rolls off the line, we'll have logged over 12 million cumulative miles of testing – more than any of its predecessors. Trust us when we say: The 2017 Super Duty is Built Ford Tough®. In every way that matters.



SO CAPABLE IT DELIVERS ALL THIS.

FIRST-IN-CLASS

- High-strength, military-grade, aluminum alloys
- Inflatable rear-seat outboard safety belts¹

BEST-IN-CLASS

- 925 lb.-ft. of diesel torque
- 430 lb.-ft. of gas torque
- 32,500 lbs. max. towing capacity²
- 27,500 lbs. max. 5th-wheel towing capacity²
- 21,000 lbs. max. conventional towing capacity²
- 7,630 lbs. max. payload capacity²
- 41,800 lbs. max. Gross Combined Weight Rating (GCWR)²

CLASS-EXCLUSIVE

- Up to 7 available cameras¹
- Adaptive steering¹
- Adaptive cruise control and collision warning with brake support¹
- BLIS[®] with trailer coverage and cross-traffic alert¹
- Customer-placed trailer camera¹
- LED sideview mirror spotlights¹
- Multicontour front seats with Active Motion^{®1}
- Power-deployable running boards¹
- PowerScope[®] power-telescoping/-folding trailer tow mirrors¹
- Remote tailgate lock and release¹
- Smart Trailer Tow Connector¹
- Standard flat load floor inside³
- Collapsible under-seat storage^{1,4} that folds into flat load floor
- Tailgate step¹
- Trailer Reverse Guidance¹
- Trailer Tire Pressure Monitoring System¹

POWER STROKE

CLASS-BEST

925
LB.-FT.
TORQUE

440
HORSE
POWER

UNSURPASSED
DIESEL
FUEL
ECONOMY¹



6.7L POWER STROKE
TURBO DIESEL

As the market leader,² Super Duty owns work.³ Loggers, landscapers, miners and oil field workers rely on it in extreme conditions. With the all-new Super Duty, they'll depend on the strongest 6.7L Power Stroke[®] V8 Turbo Diesel engine⁴ yet. New this year: twin-pilot injection for smooth acceleration; upgraded pistons, rods, crankshaft cylinder heads and gaskets. Plus, a driver-controlled engine exhaust brake with On, Off and Auto settings that allows use of engine braking to help slow the truck down and control vehicle speed. This proven diesel is paired with an equally rugged TorqShift[®] 6-speed automatic transmission. Both are designed, engineered and built by Ford. Together, they deliver its highest combination of horsepower and torque ever.

The numbers push, pull and speak for themselves. Larger fuel tanks – up to 48 gallons maximum⁴ – help improve your range of travel as well. The most tested Power Stroke diesel ever is also B20-capable. And right where it belongs in the 2017 Super Duty.

2017 Super Duty[®] | ford.com

F-350 PLATINUM Crew Cab 4x4 in Shadow Black with available equipment. ¹Unsurpassed diesel fuel economy claim for Full-Size Pickups over 8,500 lbs. GVWR. Based on Ford simulated city-suburban drive-cycle tests, consistent with SAE Standard J1321, of comparable 2017 Ford and 2016 competitive models, when properly equipped. Class is Full-Size Pickups over 8,500 lbs. GVWR based on Ford segmentation. ²Market share of Full-Size Pickups over 8,500 lbs. GVWR and Class 3-5 Chassis Cabs combined, based on Ford segmentation. ³Percentage based on IHS Automotive, U.S. heavy-duty pickup and class 2-5 pick-up truck combined new registrations (Apr 2014-Sept 2015 YTD) within EMERGENCY VEHICLES, MINING/QUARRYING, CONSTRUCTION, PETROLEUM, METAL MINING, MOVING/STORAGE, PETROLEUM REFINING & RELATED INDS MFRS, ELECTRIC GAS & SANITARY SERVICES, JUSTICE PUBLIC ORDER & SAFETY, HEAVY CONSTRUCTION EXCEPT BUILDING, FORESTRY/LUMBER PRODUCTS, MANUFACTURING, AGRICULTURE/FARM, ROAD/HIGHWAY MAINTENANCE, SPECIALIZED/HEAVY HAULING, LANDSCAPING & HORTICULTURE, WRECKING & DEMOLITION WORK, AGRICULTURE PROD-Livestock (SIC or VOCATION). ⁴Available feature.



The Built Ford Tough® 6.2L 2-valve V8 delivers the most torque of any gas engine in the class. Designed, engineered, built and torture-tested by Ford, the standard engine on F-250 and F-350 Super Duty is also E85-capable. An enhanced long-runner intake manifold combines with revised camshaft profiles this year to increase peak torque by 25 lb.-ft. over the previous generation. With significant improvements in torque performance, the 6.2L V8 delivers better working power throughout the rpm range – for improved driveability overall, and enhanced hauling and towing performance.

Alternative fuel options include a CNG/Propane Gaseous Engine Prep Package that readies your truck to be upfit for compressed natural gas (CNG) or propane autogas. Super Duty models equipped with the 6.2L engine can be converted to a bi-fuel vehicle with the ability to switch between CNG or propane and gasoline. Providing flexibility and extended range, trucks upfit to a bi-fuel system include a tank for each type of fuel. By purchasing a Super Duty upfit for CNG or propane, you may even qualify for state incentives related to alternative fuel use, infrastructure or vehicles. Visit www.afdc.energy.gov/afdc/laws for details.

CLASS-BEST GAS

430
LB.-FT.
TORQUE

385
HORSE
POWER



FLEX FUEL



The TorqShift® 6-speed SelectShift® automatic transmission with tow/haul mode delivers smooth, efficient performance. A multi-segment clutch friction-plate design improves oil flow, reduces power loss and maximizes transmission productivity. A high-efficiency fluid filter has a fluid change interval of 150,000 miles.

SelectShift and Progressive Range Select

- Manual upshift and downshift capability
- Progressive range select mode lets you reduce the available gear range in difficult road/load conditions
- Tow/haul mode helps to eliminate unwanted frequent gear-shifting on steep uphill grades, while allowing engine braking to help maintain vehicle speed when descending a steep grade

3-Plate, 2-Stage Torque Converter handles substantial horsepower and torque forces from the 6.7L Power Stroke® V8 Turbo Diesel, and helps both engines work efficiently at low rpm thanks, in part, to low-speed lockup capability (down to 900 rpm).

Live-Drive Power Takeoff Provision¹ is directly linked to the crankshaft, so the PTO output gear delivers power anytime – whether the vehicle is moving or not. With both engines, the TorqShift transmission provides stationary and mobile-mode PTO capability.²

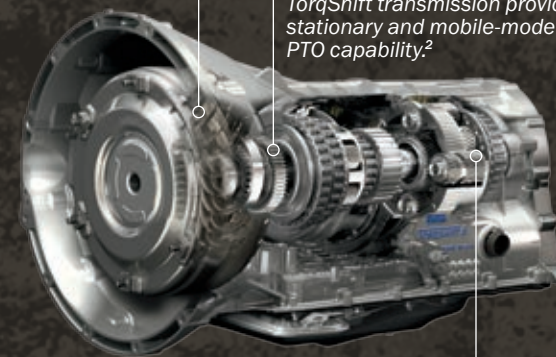

Sinter-Brazed Pinion Carriers help manage the diesel's extreme low-end torque, as well as the high shift speeds of the gas engine. When teamed with a gasoline engine, the transmission features up to 4-pinion front carriers and 6-pinion rear. Diesel models feature up to 6-pinion carriers in front and up to 8-pinion carriers in the rear.

A TorqShift-G 6-speed SelectShift automatic transmission with tow/haul mode, right-sized for weight savings and efficiency, is new this year and standard on Super Duty F-250 models with the 6.2L V8. Since engines and transmissions are both designed by Ford, each powertrain works seamlessly with chassis components and vehicle calibrations.





EVEN THE DIRT WILL BE IMPRESSED.

After all, it has the best vantage point to see where the weight savings from the all-new 2017 F-Series Super Duty have been reinvested. And it is a sight to behold.

Front suspension: optimized for increased capability with new shocks, radius arms, springs, larger lower bushings and upgraded stabilizer bars with new collars. Rear suspension: upgraded and optimized with new shocks, bushings and re-engineered leaf springs for improved stance under load. Brake master cylinder on F-450: larger, for less brake fade under extreme braking conditions. Trailer hitch receivers: bigger, stronger with more weight-carrying capability. This Super Duty is ready for down and dirty.

Front and rear axles are stronger and more capable. They've been re-engineered with new gear and bearing designs, and optimized for weight to be more efficient than their predecessors. All-new rear axles on DRW trucks have more weight-carrying and towing capability than the previous generation.

Driveshafts, transfer cases and U-joints were upgraded to handle the increased torque output of both Super Duty engines. An electromagnetic clutch in the new transfer case provides smooth and immediate shift-on-the-fly 4WD capability¹ in conditions where additional traction is required.

Standard trailer hitches are larger with increased ratings to handle heavier loads and, on many configurations, are now weight-carrying² up to the trailer hitch ratings. Hitch receiver size has also increased, and reducers are provided to cover your towing needs.

CLASS-BEST 32,500 LBS. MAX. TOWING.

Towing numbers lead the class across the board. Best-in-class max. towing: Super Duty F-450 at a whopping 32,500 lbs.¹ Best-in-class max. 5th-wheel towing: F-350 DRW at 27,500 lbs.¹ And best-in-class conventional towing: F-350 DRW at 21,000 lbs.¹ If you need to tow more than any other truck in the class, you'll be in a Super Duty. It's optimized for heavy hauling. So you can pull the most weight¹ – confidently.

To help you handle it all, the 2017 F-Series Super Duty is our smartest and most capable towing machine. Ever. Providing you with an unprecedented level of towing confidence with even the largest loads. Smart technology helps make towing easier than ever: Cameras² aid in hooking up your trailer; class-exclusive adaptive cruise control² makes handling all that weight seem almost effortless; and adaptive steering² makes parking easier at your destination.



IMPROVE YOUR LINES OF SIGHT

When there's valuable equipment in tow, what you can see makes all the difference. With up to 7 available cameras,¹ the all-new 2017 Super Duty helps you see more than ever before – solidifying our leadership in delivering the most capable, high-tech towing technology. Introducing your ultimate towing machine.

A front 180-degree camera with washer^{1,2} not only helps to see ahead, but around tight corners as well. It can see to the left and right before you have a line of sight, displaying a view around corners, down alleys and out of parking spots as you slowly drive forward.

A camera in each sideview mirror,^{1,2} along with the front and rear cameras, generates a 360-degree view. This all-around view of Super Duty is displayed on the 8" color LCD screen in the center stack (shown top right).

A forward-facing camera¹ is utilized by lane-keeping alert.^{1,3} It can detect lane markings and send vibration pulses to the steering wheel if it senses Super Duty drifting unintentionally out of its lane.

A center high-mounted stop lamp (CHMSL) camera¹ with zoom function helps provide greater visibility of the cargo in the cargo box while in Reverse (shown middle right), and is particularly helpful when connecting a 5th-wheel/gooseneck trailer.

A rear view camera¹ with zoom function, mounted in the tailgate handle, provides a view of what's behind Super Duty and helps in the hookup of conventional trailers. It is one of the cameras used by the 360-degree camera with Split-View Display.¹

A customer-placed trailer camera¹ can be attached to the rear of your trailer. It shows you what's behind the trailer when backing up, and it's weatherproof. The image can be accessed on the 8" color LCD screen in the center stack.



360-Degree Camera Split-View Display



CHMSL Camera View



Trailer Reverse Guidance¹ automatically switches between side and rear camera views to show you what is most relevant while backing up your trailer, and provides overlays to guide you.



After surviving countless hours of abuse at the hands of Ford engineers, this high-strength, military-grade, aluminum alloy cargo box is reporting for duty. Super Duty. Best-in-class payload sits inside these walls. In fact, max. payload numbers have increased across this F-Series lineup. And for good reason. Panel thickness of the cargo box: upgraded. Reinforcements underneath the box: fortified. Dent and ding resistance inside the box: better than steel. Susceptibility to red rust: gone.

Accessing your payload is easy, too, thanks to extended step bars¹ that reach to the side of the cargo box, as well as our class-exclusive tailgate step¹ in back. To help increase your confidence while hauling heavy loads, every Super Duty features AdvanceTrac[®] with RSC[®] (Roll Stability Control™) – that now includes DRW models too. It utilizes 2 gyroscopic sensors to automatically help you avoid skidding and fishtailing, helping you keep all wheels firmly planted.² Load up. Head out.

**CLASS-BEST
7,630 LBS.
MAX. PAYLOAD.³**



2017 Super Duty[®] | ford.com

F-350 XL Regular Cab DRW 4x2 in Oxford White with available equipment. ¹Available feature. ²Remember that even advanced technology cannot overcome the laws of physics. It's always possible to lose control of a vehicle due to inappropriate driver input for the conditions. ³When properly equipped.





FORTIFIED FOR ACTION.

Day or night, the all-new Super Duty provides the tools you need to finish any job. Class-exclusive LED sideview mirror spotlights¹ can light your work site well into the night. They join quad-beam LED headlamps¹ and LED taillamps.² LED box lighting¹ smartly illuminates the cargo box with forward-facing lights. Turn them on with the button in the bed or the headlamps control in the cab.

Our class-exclusive tailgate step¹ with grab handle is fully integrated inside the tailgate and drops down in one easy motion when needed. First-in-class remote tailgate release¹ with power remote locking opens the tailgate with your key fob. Lock, unlock and lower it, hands-free. When activated, the tailgate gradually lowers to a flat position. Class-exclusive BoxLink™ with locking cleats⁴ helps keep your cargo in place. Load dirt bikes and ATVs with ease thanks to class-exclusive stowable loading ramps.⁵ When finished, stow the ramps with the BoxLink system.





POWERED FOR PRODUCTIVITY.

The 8" color LCD productivity screen¹ in the instrument cluster of the all-new Super Duty is your new command center. Keep your most used screens front and center with MyView. Just choose your favorites (up to 7) and put them in one consolidated view for greater convenience. Unique Super Duty screens include a digital turbo gauge for the 6.7L Power Stroke® V8 Turbo Diesel engine,¹ and a DEF gauge.

The Individual Tire Pressure Monitoring System² not only notifies you if any individual tire's pressure is low, but the system tells you how low. Track towing information, such as trailer brake controller¹ settings, vehicle pitch and steering angle, and profiles of up to 10 trailers – including accumulated miles on each. A class-exclusive Trailer Tire Pressure Monitoring System¹ can monitor and display the individual tire pressures of a connected trailer, and warn you if any tire is low. A power distribution screen when driving off road even shows you which wheels are receiving the most power. In Super Duty, all the info you need is front and center.



Trailer Tire Pressure Monitoring Screen



DEF Tank Status Screen



Off-Road Status Screen



ENLIGHTEN ANY ROAD.

You can in the all-new 2017 F-Series Super Duty, the smartest Super Duty ever. It's loaded with driver-assist features¹. Sophisticated radar.² And strategically placed cameras.³ They're at your service to help you navigate a crowded job site, avoid a collision, stay in your lane, and so much more.

Adaptive cruise control helps maintain your choice of speed and preset gaps from the vehicle in front of you. It can also alert you to a potential collision. If one is detected, adaptive cruise control and collision warning with brake support^{1,2} flashes a warning via a heads-up display on the windshield, sounds an alarm, and can pre-charge the brake system to provide full responsiveness when you do brake.

First-in-class adaptive steering^{1,2} adapts to different driving conditions and reduces the amount of steering input needed, depending on speed and load. This helps make Super Duty more manageable to drive, especially with a load in tow. Backing up, trailering, and parking lot maneuvering will all be easier than the previous generation.

Trailer sway control helps you handle all that weight when towing. The system monitors the motions of the truck to detect trailer sway and selectively brakes as needed,³ helping you maintain control of the truck and the trailer.

Lane-keeping alert^{1,2,4} can detect lane markings and send vibration pulses to the steering wheel if it senses Super Duty drifting unintentionally out of its lane.

BLIS® (Blind Spot Information System) with trailer coverage^{1,2} notifies you with a light in either sideview mirror if its radar sensors detect a vehicle in the corresponding blind spot. The system has been optimized for Super Duty to extend the range of BLIS to include a conventional trailer, once programmed into the productivity screen.

4x4xFAR.

Until the pavement is down on a job site, you've got to get your heavy equipment and tools through mud, sand and difficult terrain. Thankfully, on Super Duty 4x4 models with electronic shift-on-the-fly² engaging 4WD is as simple as setting the proven manual-locking front hubs to AUTO and turning a dial on the instrument panel. Monitor your truck's pitch, roll, steering angle and driveline status with the off-road display in the 8" productivity screen.¹

To increase your confidence even more, select the FX4 Off-Road Package. Transfer case and fuel tank skid plates, Hill Descent Control™ (now available on DRW models for the first time), and off-road-tuned Rancho® shocks help get you ready for serious, low-speed crawling. An electronic-locking rear differential¹ (SRW models) uses a true mechanical dog-clutch mechanism to lock the rear axle shafts together so they turn at the same speed for maximum gripping power. In the all-new 2017 Ford Super Duty, you're well prepared to conquer the toughest terrain.



2017 Super Duty® | ford.com

F-250 KING RANCH® Crew Cab 4x4 in Ruby Red/Caribou two-tone with FX4 Off-Road Package and available equipment. Try to avoid water higher than the bottom of the hubs and proceed slowly. Refer to your owner's manual for detailed information regarding driving through water. ¹Available feature.





SADDLE UP. RIDE LIKE A KING.

You can, in all-new cabs that are longer across the lineup – Regular Cab, SuperCab and Crew Cab. On KING RANCH[®] you can massage your lower back and upper leg area, and change your seat contour, with the heated and cooled, leather-trimmed 10-way power front seats equipped with Active Motion^{®1}. The driver's seat, power-adjustable pedals, power sideview mirrors, and power-tilt and -telescoping steering column all feature memory to make life even more convenient. On the leather-wrapped center console lid, the KING RANCH Running W logo is prominently displayed.

Listen to everything you love with SiriusXM[®] Satellite Radio¹. Get over 150 channels including all kinds of commercial-free music, plus every major sport and the best talk, news, comedy and entertainment. And you'll hear it all with a 6-month trial subscription to the All Access package, included with your new Super Duty. So you can rock your ride, plus listen anywhere online and on the SiriusXM app.² All in the quietest Super Duty ever.

2017 Super Duty[®] | ford.com

KING RANCH Crew Cab 4x4 leather-trimmed interior in Mesa Brown with available equipment. ¹Available feature. ²SiriusXM audio and data services each require a subscription sold separately, or as a package, by Sirius XM Radio Inc. If you decide to continue service after your trial, the subscription plan you choose will automatically renew thereafter and you will be charged according to your chosen payment method at then-current rates. Fees and taxes apply. To cancel you must call SiriusXM at 1-866-635-2349. See SiriusXM Customer Agreement for complete terms at www.siriusxm.com. All fees and programming subject to change. Trial subscriptions not available in AK and HI.





NOW YOU'RE TALKING.

SYNC 3

In addition to all the voice-activated benefits of SYNC^{®1,2} – placing and answering calls, and controlling music from your devices – you'll love the easy-to-use interface of SYNC 3². An 8" color LCD screen displays phone, audio and navigation¹ features. Enhanced voice recognition lets you give simple commands. A capacitive touchscreen includes a convenient swipe feature, as well as pinch-to-zoom functionality within navigation.¹ SYNC 3 also brings you the options of Apple CarPlay^{™3} and Android Auto^{™4}.

Voice-Activated Navigation System¹

Includes a 5-year complimentary trial subscription to SiriusXM[®] Traffic and Travel Link[®] services.⁵ Global Positioning System (GPS) technology is combined with available 3-D mapping and provides voice-guided turn-by-turn directions. You'll get detailed traffic information, plus current and forecasted weather and fuel station locations and prices.

SYNC AppLink

Use your voice to control some of your favorite compatible mobile apps (like Pandora[®] and iHeartAuto), thanks to SYNC AppLink^{®1,6}.

Siri Seamless Integration

Bring the power of Siri[®] into Super Duty with Siri Eyes Free⁷, your paired iPhone[®] and a long press of the voice-recognition button on the steering wheel.

Automatic Updates Over Wi-Fi

Keep SYNC 3 current with the latest software as new updates become available.⁸ All you need is a Wi-Fi[®] connection.

2017 Super Duty[®] | ford.com

¹Available feature. ²Don't drive while distracted. Use voice-operated systems when possible; don't use handheld devices while driving. Some features may be locked out while the vehicle is in gear. Not all features are compatible with all phones. Message and data rates may apply. ³Requires phone with compatible version of Apple iOS and active data service. SYNC does not control Apple CarPlay while in use. Apple is solely responsible for their functionality. Message and data rates may apply. ⁴Requires phone with compatible version of Android Auto and active data service. SYNC does not control Android Auto while in use. Google and other third parties are responsible for their respective functionality. ⁵SiriusXM audio and data services each require a subscription sold separately, or as a package, by SiriusXM Radio Inc. If you decide to continue service after your trial, the subscription plan you choose will automatically renew thereafter and you will be charged according to your chosen payment method at then-current rates. Fees and taxes apply. To cancel you must call SiriusXM at 1-866-635-2349. See SiriusXM Customer Agreement for complete terms at www.siriusxm.com. All fees and programming subject to change. Trial subscriptions not available in AK and HI. ⁶SYNC AppLink is available on select models and compatible with select smartphone platforms and requires any compatible apps to be installed and running on a capable smartphone while connected to SYNC. Commands may vary by phone and AppLink software. Message and data rates may apply. ⁷Requires SYNC 3. ⁸Optional Navigation System map updates cannot be received via Wi-Fi and require a separate update.



AN OPEN AND SHUT CASE ON PRODUCTIVITY.

To keep you highly productive, smart storage is everywhere in Super Duty. Even under the rear seat. First, on Crew Cab models, deployable under-seat storage¹ can fold into the floor when not in use for a convenient flat load floor. When needed, the deployable partition raises up for helpful storage that can be divided and locked when the seat is folded down. Next, 2 glove compartments, including a unique upper compartment, more than double the glove box storage space of the previous generation. And the deep front center console¹ is large enough for hanging file folders. Lastly, on SuperCab, enjoy rear doors that now open to 170° – with no B-pillars to obstruct entry and loading. Case closed.



BAD, BADDER, BADDEST.

F-250

MAXIMUM CAPABILITIES¹

Towing: 18,600 lbs.
Payload: 4,200 lbs.
GVWR: 10,000 lbs.
GCWR: 25,700 lbs.

ENGINES

6.2L Gas V8
6.7L Power Stroke® V8 Turbo Diesel

DRIVETRAINS

Single Rear Wheel (SRW) 4x2 or 4x4

CAB TYPES

Regular Cab, SuperCab or Crew Cab

BOX LENGTHS

6¾' or 8'

F-350

MAXIMUM CAPABILITIES¹

Towing: 32,000 lbs.
BEST-IN-CLASS Payload: 7,630 lbs.
GVWR: 14,000 lbs.
GCWR: 40,000 lbs.

ENGINES

6.2L Gas V8
6.7L Power Stroke V8 Turbo Diesel

DRIVETRAINS

SRW or Dual Rear Wheel (DRW); 4x2 or 4x4

CAB TYPES

Regular Cab, SuperCab or Crew Cab

BOX LENGTHS

6¾' or 8'

F-450

MAXIMUM CAPABILITIES¹

BEST-IN-CLASS Towing: 32,500 lbs.
Payload: 5,320 lbs.
GVWR: 14,000 lbs.
BEST-IN-CLASS GCWR: 41,800 lbs.

ENGINE

6.7L Power Stroke V8 Turbo Diesel

DRIVETRAIN

DRW 4x4

CAB TYPE

Crew Cab

BOX LENGTH

8'



STANDARD FEATURES

Mechanical

Axle – Front, narrow-track, monobeam (F-250/F-350 4x4)
 Axle – Front, narrow-track, Twin-I-Beam (F-250/F-350 4x2)
 Axle – Front, wide-track, monobeam (F-450)
 Axle – Rear, 4.30 limited-slip (F-450)
 Axle – Rear, non-limited slip (F-250/F-350)
 Brakes – Power 4-wheel disc with Anti-Lock Brake System (ABS)
 Jack – 2-ton mechanical (SRW)
 Jack – 4-ton hydraulic (DRW)
 Manual locking hubs (4x4)
 Oil monitor – Intelligent Oil-Life Monitor® (diesel engine)
 Oil monitor – Oil-life minder (gas engine)
 Spare wheel, tire, lock and frame-mounted carrier
 Stabilizer bar – Front
 Stabilizer bar – Rear (DRW)
 Stationary Elevated Idle Control (SEIC)¹
 Steering – Hydraulic power-assisted
 Steering damper
 Suspension – Front, coil springs
 Suspension – Heavy-duty gas shock absorbers
 Suspension – Rear, leaf-spring
 Trailer sway control
 Trailer tow – 15K Built Ford Tough® trailer hitch receiver with 2.5" hitch and 2"-2.5" sleeve reducer (SRW with gas engine)
 Trailer tow – 21K Built Ford Tough trailer hitch receiver with 3" hitch and 2"-2.5" and 2.5"-3" sleeve reducers (SRW with diesel engine; DRW)
 Trailer tow – 7-wire harness with relays and 7-/4-pin connector (F-250/F-350)
 Trailer tow – 7-/4-pin connector, 4.30 limited-slip rear axle and 33,000-lb. GCWR (F-450)

Driver-Assist Technology

Autolamp with rainlamp
 Hill start assist

Seating

Rear – 60/40 split flip-up seat with head restraints (SuperCab and Crew Cab)

Interior

Cabin air filter
 Climate control – Air conditioning
 Coat hooks
 Dash-top tray
 Display – Outside temperature

Glove compartments – 2, illuminated and lockable
 Grab handles – Driver and front-passenger, and rear-passenger on Crew Cab
 Lighting – Dome light
 Lighting – Dual map lights (front on Regular Cab/SuperCab; front and rear on Crew Cab)
 Overhead console with dual storage bins (SuperCab/Crew Cab)
 Power outlets – 12-volt powerpoint, 2 in instrument panel
 Windows – Rear quarter flip-out (SuperCab)

Exterior

Daytime running lamps – Configurable
 Doors – 2 (Regular Cab)
 Doors – 4 (SuperCab/Crew Cab)
 Front fender vents
 Front license plate bracket
 Lighting – 3-blink lane change signals
 Lighting – Center high-mounted stop lamp (CHMSL) with cargo lamp
 Lighting – LED roof marker/clearance lamps (DRW)
 Pickup box – Box rail and tailgate moldings
 Pickup box – Partitionable and stackable
 Pickup box – Tie-down hooks (4 with 6¾" box; 6 with 8" box)
 Tailgate – Removable with key lock and tailgate assist
 Tow hooks – Front, 2
 Underhood service lamp
 Windshield wipers – Variable-intermittent with washers

Safety & Security

Airbags – Driver and right-front-passenger front²
 Airbags – Front-seat side²
 Airbags – Front-passenger airbag deactivation switch (Regular Cab and SuperCab)
 Airbags – Safety Canopy® System with side-curtain airbags² and rollover sensor
 AdvanceTrac® with RSC® (Roll Stability Control™)
 Belt-Minder® front safety belt reminder
 Child-safety-seat top tether anchors (Regular Cab front passenger, and all rear-seat positions)
 Front height-adjustable shoulder safety belts
 Individual Tire Pressure Monitoring System (F-250/F-350, excludes spare)
 MyKey®
 SecuriLock® Passive Anti-Theft System
 SOS Post-Crash Alert System™

Engines

	6.7L Power Stroke® V8 Turbo Diesel OHV (32-valve)	6.2L 2-Valve Gas V8 FFV SOHC
Configuration	OHV (32-valve)	SOHC
Electronic fuel injection	High-pressure common-rail	Sequential multi-port
Induction system	Single-sequential turbocharger; charged air cooler	Specially tuned
Battery	Dual 12-volt; 750-CCA/78-amp-hr	Single 12-volt; 650-CCA/72-amp-hr (XL) Single 12-volt; 750-CCA/78-amp-hr (XL/LARIAT/KING RANCH/PLATINUM)
Alternator	175-amp (XL/XLT) 220-amp (LARIAT/KING RANCH®/PLATINUM) Optional 220-amp (XL/XLT) Optional dual combined 332-amp Optional dual combined 377-amp	157-amp (XL/XLT) 220-amp (LARIAT/KING RANCH/PLATINUM)
Cooling system	Pressurized series flow	Pressurized series flow
Cylinders	8, aluminum heads	8, aluminum heads
Block material	Compacted graphite iron	Cast iron
Valve operation	Push rod/rocker arms	Roller-rocker shafts
Camshaft drive	Gear	Silent chain
Bore/stroke	3.90"/4.25"	4.02"/3.74"
Compression ratio	16.2:1	9.8:1
Horsepower @ rpm	440 @ 2,800	385 @ 5,750 ³
Torque lb.-ft. @ rpm	925 @ 1,800-2,000	430 @ 3,800
Recommended fuel	Ultra-low-sulfur diesel or B20 (containing 20% or less biodiesel)	Regular unleaded or E85; bi-fuel-capable CNG or propane autogas (requires upfit)

Transmissions

	TorqShift® 6-Speed SelectShift® Automatic with Tow/Haul Mode (F-250 with diesel engine and F-350/F-450)	TorqShift-G 6-Speed SelectShift Automatic with Tow/Haul Mode (F-250 gas engine only)
Case Material	Aluminum	Aluminum
PTO	Live-drive with stationary and mobile modes; split-shaft capability (diesel only); PTO port located on driver's side	n/a
Gear Ratios	1st 3.97:1 2nd 2.31:1 3rd 1.51:1 4th 1.14:1 5th 0.85:1 6th 0.67:1 Reverse 3.12:1	1st 4.17:1 2nd 2.34:1 3rd 1.52:1 4th 1.14:1 5th 0.87:1 6th 0.69:1 Reverse 3.40:1

Mechanical

Front Suspension

Axle (max. rating @ ground) – 5,250 lbs. (F-250/F-350 4x2); 6,000 lbs. (F-250/F-350 w/3.31 axle delete); 6,000 lbs. (F-250/F-350 4x4); 7,000 lbs. (F-450)
 Shock absorbers – 1.38" gas type

Rear Suspension

Axle (max. rating @ ground) – 6,200 lbs. (F-250); 7,280 lbs. (F-350 SRW); 9,650 lbs. (F-350 DRW/F-450)
 Shock absorbers – 1.38" gas type

Steering

Type – Hydraulic power-assisted with recirculating ball gear and damper
 Overall ratio – Variable

Brakes

Rotor diameter (front/rear) – 14.29"/14.29" (F-250/F-350); 15.39"/15.74" (F-450)

Wheels

Steel or aluminum
 Size – 17", 18" or 20" (F-250/F-350); 19.5" (F-450)
 Number of studs – 8 (F-250/F-350); 10 (F-450)
 Bolt-circle diameter – 6.69" (170-mm) SRW; 7.87" (200-mm) F-350 DRW; 8.86" (225-mm) F-450



6 auxiliary upfitter switches⁴ are mounted overhead, within easy reach of front-seat occupants.

Up to 6 power sources, including 12-volt powerpoints⁴ and 110-volt power outlets⁴, help you recharge your equipment easily. And the combined max. output of these outlets is increased to 400 watts in Park and 300 watts when driving.

¹Final-stage manufacturer must supply control switches. ²Always wear your safety belt and follow airbag warning label instructions. ³Certified to SAE J1349. ⁴Available feature.

TRIMS

S : Standard A : Available O : Optional

XL



XL Regular Cab cloth-trimmed interior in Dark Earth Gray with XL Value Package, 40/20/40 split front seat and available equipment.

XLT



XLT SuperCab cloth-trimmed interior in Medium Earth Gray with XLT Premium Package, 40/console/40 front bucket seats and available equipment.

LARIAT



LARIAT Crew Cab leather-trimmed interior in Medium Light Camel with 40/console/40 front bucket seats and available equipment.

KING RANCH®



KING RANCH Crew Cab leather-trimmed interior in Mesa Brown with 40/console/40 front bucket seats and available equipment.

PLATINUM



PLATINUM Crew Cab leather-trimmed interior in Black with 40/console/40 front bucket seats and available equipment.

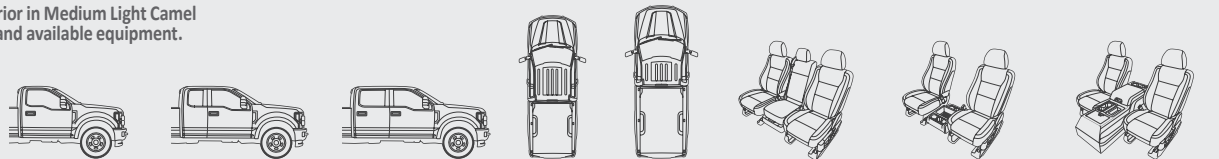

	Regular Cab	SuperCab	Crew Cab	6 3/4' Box Size	8' Box Size	40/20/40 split front seat	40/mini-console/40 front bucket seats	40/console/40 front bucket seats
XL	A	A	A	A	A	S	O	O
XLT	A	A	A	A	A	S	O	O
LARIAT		A	A	A	A	O		S
KING RANCH			S	A	A			S
PLATINUM			S	A	A			S

BUILD YOUR SUPER DUTY®

S : Standard O : Optional P : Package Content

XL	XL	LARIAT	KING RANCH®	PLATINUM	
S	S	S	S	S	Mechanical
					6.2L SOHC 2-valve Gas V8 Flex Fuel E85-capable engine (n/a on F-450)
5/0	5/0	5/0	5/0	5/0	6.7L Power Stroke® V8 Turbo Diesel B20-capable engine with driver-controlled engine exhaust braking (standard on F-450)
S	S	S	S	S	TorqShift® 6-speed SelectShift® automatic transmission with tow/haul mode (F-250 with gas engine)
S	S	S	S	S	TorqShift® 6-speed SelectShift® automatic transmission with tow/haul mode (F-250 with diesel engine and F-350/F-450)
S	S	S	S	S	Axle – Rear, 3.31 non-limited-slip ¹ (SRW diesel engine)
5/0	5/0	5/0	5/0	5/0	Axle – Rear, 3.55 non-limited-slip ¹ (standard on F-350 DRW with diesel engine; optional on SRW 4x4 with diesel engine)
S	S	S	S	S	Axle – Rear, 3.73 non-limited-slip (F-250/F-350 with gas engine)
0	0	0	0	0	Axle – Rear, 3.55 limited-slip (F-350 DRW with diesel engine)
0	0	0	0	0	Axle – Rear, 3.73 limited-slip (F-350 DRW with gas engine)
0	0	0	0	0	Axle – Rear, 4.10 limited-slip (F-350 DRW with diesel engine)
0	0	0	0	0	Axle – Rear, 4.30 limited-slip (F-350 DRW with gas engine)
0	0	0	0	0	Axle – Rear, 3.31 electronic-locking ¹ (SRW with diesel engine)
0	0	0	0	0	Axle – Rear, 3.55 electronic-locking ¹ (SRW with diesel engine)
0	0	0	0	0	Axle – Rear, 3.73 electronic-locking (SRW with gas engine)
0	0	0	0	0	Axle – Rear, 4.30 electronic-locking (SRW with gas engine)
S	S				Alternator – 157-amp heavy-duty ¹ (gas engine)
S	S				Alternator – 175-amp heavy-duty ¹ (diesel engine)
0	0	S	S	S	Alternator – 200-amp extra-heavy-duty ¹ (gas engine)
0	0	S	S	S	Alternator – 220-amp extra-heavy-duty ¹ (diesel engine)
0	0	0	0	0	Alternator – 240-amp extra-extra-heavy-duty ¹ (gas engine)
0	0	0	0	0	Alternator – Dual heavy-duty, 332-amp total ¹ (diesel engine)
0	0	0	0	0	Alternator – Dual extra-heavy-duty, 377-amp total ¹ (diesel engine)
S					Battery – 650-CCA, 72-amp-hr, single (gas engine)
	S	S	S	S	Battery – 750-CCA, 78-amp-hr, single (gas engine)
5/0	5/0	5/0	5/0	5/0	Battery – 750-CCA, 78-amp-hr, dual (standard with diesel engine; optional with gas engine)
S	S	S	S	S	Drivetrain – 4x2 (F-250/F-350)
5/0	5/0	5/0	5/0	5/0	Drivetrain – 4x4 (standard on F-450; optional on F-250/F-350)
0	0	0	0	0	Engine block heater (standard where required)
0	0				Engine idle shutdown – 5-minute ¹
0	0				Engine idle shutdown – 10-minute ¹
0	0				Engine idle shutdown – 15-minute ¹
0	0				Engine idle shutdown – 20-minute ¹
S	S	S			Fuel tank – 29-gallon (142" and 148" WB with diesel engine)
S	S	S	S	S	Fuel tank – 34-gallon (142" and 148" WB with gas engine; 160" and 164" WB)
S	S	S	S	S	Fuel tank – 48-gallon (176" WB with gas engine)
S	S	S	S	S	Fuel tank – 48-gallon (176" WB with diesel engine)
0	0				Operator-commanded exhaust filter regeneration (diesel engine)
0	0	0	0	0	Power takeoff (PTO) provision with transmission-mounted live-drive and stationary modes ¹

XL	XL	LARIAT	KING RANCH	PLATINUM	
5/0	5/0	S	S	S	Spare wheel, tire, frame-mounted carrier and jack (optional with pickup box delete only)
0	0	0	0	0	Trailer tow – 5th-wheel hitch, 18,000-lb. rating ^{1,2} (SRW)
0	0	0	0	0	Trailer tow – 5th-wheel hitch, 27,500-lb. rating ^{1,2} (DRW)
0	0	0	0	0	Trailer tow – Gooseneck dual hitch kit includes one 2 5/16" gooseneck ball, one 3" gooseneck ball, and two safety chain tie-down bars ^{1,2} (F-450)
0	0	0	0	0	Trailer tow – Gooseneck hitch kit ^{1,2} (F-250/F-350)
5/0	S	S	S	S	Trailer tow – Trailer brake controller with Smart Trailer Tow Connector (standard on DRW)
S	S				Transfer case – Manual (4x4)
0	0	S	S	S	Transfer case – Electronic shift-on-the-fly (ESOF) (4x4)
0	0	0	0	0	Upfitter interface module (Fleet only)
		0	0	0	Wheel locks (20" wheels only)
S					Wheels – 17" argent-painted steel with painted center cap (SRW)
S	S				Wheels – 17" argent-painted steel without center cap (F-350 DRW)
0	0				Wheels – 17" cast-aluminum with bright center cap (SRW)
0	0	S	S	S	Wheels – 17" polished forged-aluminum with bright center cap (F-350 DRW; KING RANCH includes unique center cap)
0					Wheels – 18" argent-painted steel with painted center cap (F-350 SRW)
P	S				Wheels – 18" cast-aluminum with bright center cap (SRW)
		S	S		Wheels – 18" bright-machined cast-aluminum with bright center cap (SRW; KING RANCH includes unique center cap)
P	P	P			Wheels – 18" chrome-like PVD with bright center cap (SRW; KING RANCH includes unique center cap)
S	S	S	S	S	Wheels – 19.5" polished forged-aluminum with bright center cap (F-450; KING RANCH includes unique center cap)
		0			Wheels – 20" premium cast-aluminum with bright center cap (SRW 4x4)
		0	0		Wheels – 20" chrome-like PVD with bright center cap ¹ (SRW 4x4 with Chrome Package; KING RANCH includes unique center cap)
		0	0		Wheels – 20" chrome-like PVD with bright center cap ¹ (F-350 SRW 4x4 with diesel engine and Chrome Package; KING RANCH includes unique center cap)
			0		Wheels – 20" premium painted cast-aluminum with KING RANCH center cap (SRW 4x4)
			S		Wheels – 20" polished aluminum with bright center cap ¹ (SRW)
			S		Wheels – 20" polished aluminum with bright center cap ¹ (F-350 SRW with diesel engine)
0	0				Wheels – Stainless steel covers, front and rear ^{1,3} (F-350 DRW)
S	0				LT245/75R17E BSW all-season (SRW 4x2)
S	S	S	S	S	LT245/75R17E BSW all-season (F-350 DRW 4x2)
S	0				LT245/75R17E BSW all-season plus (SRW 4x4)
S	S	S	S	S	LT245/75R17E BSW all-season plus (F-350 DRW 4x4)
0	0				LT245/75R17E BSW all-terrain ¹ (SRW)
0	0	0	0	0	LT245/75R17E BSW all-terrain (F-350 DRW)
0	0	0	0	0	LT245/75R17 OWL all-terrain (F-350 DRW)

XL	XL	LARIAT	KING RANCH	PLATINUM	
0	0				LT265/70R17E OWL all-terrain (SRW)
0	S	S	S		LT275/65R18E BSW all-season ¹ (SRW)
0	0	0	0		LT275/70R18E BSW all-terrain plus ¹ (SRW 4x4)
P	0	0	0		LT275/70R18E OWL all-terrain plus (SRW 4x4)
		0			LT275/65R20E OWL all-season (SRW 4x4)
		0	0	S	LT275/65R20E OWL all-terrain (SRW 4x4)
S	S	S	S	S	225/70R19.5G BSW all-season (F-450)
					Driver-Assist Technology
			0	0	Adaptive cruise control and collision warning with brake support ¹
0	0	0	0	S	BLIS® (Blind Spot Information System) with trailer coverage and cross-traffic alert
		0	S	S	Reverse Sensing System ¹
		P	0	S	Steering – Adaptive steering ¹
0	S				SYNC® Voice Recognition Communications and Entertainment System with 4.2" center stack screen, 911 Assist®, AppLink®, and 1 smart-charging USB port ¹
0	0	S	S	S	SYNC 3 Enhanced Voice Recognition Communications and Entertainment System with 8" color LCD capacitive touchscreen in center stack with swiping capability, 911 Assist, AppLink and 2 smart-charging USB ports ¹
P	P	S	S		Windshield wipers – Rain-sensing
					Seating
S					2-way adjustable driver and right-front-passenger head restraints
S	S	S	S	S	4-way adjustable driver and right-front-passenger head restraints
S					Front – Heavy-duty vinyl 40/20/40 split seat with 2-way manual seat adjust, driver's side manual lumbar, and folding armrest with cupholders and storage
0					Front – Cloth 40/20/40 split seat with 2-way manual seat adjust, driver's side manual lumbar, and folding armrest with cupholders and storage
0					Front – Heavy-duty vinyl bucket seats with mini-console and driver's side manual lumbar (Regular Cab only)
0					Front – Cloth bucket seats with mini-console and driver's side manual lumbar
S					Front – Cloth 40/20/40 split seat, center under-seat lockable storage with 12-volt powerpoint, 2-way manual seat adjust, driver's side manual lumbar, and folding armrest with cupholders and storage
0					Front – Cloth bucket seats with 8-way power driver seat, 2-way manual passenger seat, driver's side manual lumbar, and flow-through center console with lockable storage and 2 rear-facing powerpoints ¹ (SuperCab and Crew Cab only)
	S				Front – Leather-trimmed 10-way power bucket seats and flow-through center console with lockable storage and 2 rear-facing powerpoints
	0				Front – Leather-trimmed 10-way power 40/20/40 split seat, center under-seat lockable storage with 12-volt powerpoint, and folding armrest with cupholders and storage
	P	S	S		Front – Leather-trimmed heated and cooled 10-way power bucket seats and flow-through center console with lockable storage and 2 rear-facing powerpoints

¹Restrictions may apply. See your dealer for details. ²Requires 5th-Wheel/Gooseneck Trailer Tow Prep Package. ³Ford Licensed Accessory.

BUILD YOUR SUPER DUTY®

S : Standard O : Optional P : Package Content

XL	XLT	LARIAT	KING RANCH®	PLATINUM	
		P	S	S	Seating (continued)
		P	S		Front – Easy-entry/-exit driver's seat feature with memory
		P	S		Front – Multicontour seats with Active Motion®
S					Rear – Heavy-duty vinyl
O	S				Rear – Cloth
		S			Rear – Premium vinyl (SuperCab)
		S	S	S	Rear – Leather-trimmed (Crew Cab)
		S	S	S	Rear – Under-seat fold-flat storage, lockable and partitionable, with 12-volt powerpoint (Crew Cab)
		S	S		Rear – Under-seat storage with 12-volt powerpoint (SuperCab)
		S	S	S	Rear – Fold-down center armrest with dual integrated cupholders (Crew Cab)
		O	O	S	Rear – Heated outboard seats¹ (Crew Cab)
					Interior
S					AM/FM stereo with 4 speakers (Regular Cab)
S					AM/FM stereo with 6 speakers (SuperCab/Crew Cab)
P	S				AM/FM stereo/single-CD player with MP3 capability and 4 speakers (Regular Cab)
P	S				AM/FM stereo/single-CD player with MP3 capability and 6 speakers (SuperCab/Crew Cab)
		S	S	S	Audio System from Sony® with AM/FM stereo/single-CD player with MP3 capability, 10 speakers and HD Radio™ Technology
		O	O	S	Voice-activated Navigation System with integrated SiriusXM Traffic and Travel Link® with 5-year subscription¹
O	S	S	S	S	SiriusXM® Satellite Radio with 6-month trial subscription¹
P	S	S	S	S	Accessory delay for power features
		P	S	S	Ambient lighting
O					Center console – Mini-console
		O	S		Center console – Flow-through with vinyl lid
			S	S	Center console – Flow-through with leather-wrapped lid
		O	O	O	Center console – Vehicle Safe by Console Vault²
S	S				Climate control – Single-zone manual
		S	S	S	Climate control – Dual-zone electronic automatic temperature control
O	O	O	O	O	Climate control – Rapid-heat supplemental cab heater¹ (diesel engine; standard where required)
P	S	S	S	S	Cruise control
S					Display – 2.3" productivity screen in instrument cluster
O	S				Display – 4.2" LCD productivity screen in instrument cluster¹
		P	S	S	Display – 8" configurable color LCD productivity screen in instrument cluster
			S		Door-sill scuff plates – Illuminated
			S		Door trim – Sandalwood film appliqué
			S		Door trim – Khaya wood appliqué
			S		Door trim – Figured Eucalyptus wood appliqué
		O	O		Flooring – All-weather floor mats¹
S	O	O			Flooring – Black vinyl/carpet delete
		S	S	S	Flooring – Carpet with front and rear carpeted floor mats¹
		O	O		Flooring – Premium vinyl with front and rear carpeted floor mats

XL	XLT	LARIAT	KING RANCH®	PLATINUM	
		P	S	S	Locks – Intelligent Access with push-button start
P	S	S	S	S	Locks – Power door and tailgate with autolock/unlock
P	S	S			Locks – Remote Keyless Entry System with 2 integrated keyhead transmitter remotes
S	S				Mirror – Day/night rearview
		S	S	S	Mirror – Auto-dimming rearview
		P	S		Power-adjustable pedals
		P	S	S	Power-adjustable pedals with memory
O	O	S	S	S	Power outlet – 110V/400W, 1 in instrument panel; also includes 1 rear-facing on the flow-through center console, if equipped¹
S	S	S			Steering column – Manual-tilt/-telescoping
		P	S	S	Steering column – Power-tilt/-telescoping with memory
S	S				Steering wheel – Black urethane
		P	S	S	Steering wheel – Color-coordinated leather-wrapped
		P	S	S	Steering wheel – Heated
		O	S	S	Universal garage door opener
O	O	O	O	O	Upfitter switches – 6, located in overhead console¹
S					Visors – Adjustable driver with pocket and front-passenger with mirror
		S			Visors – Adjustable driver and front-passenger with covered mirrors
		S	S	S	Visors – Adjustable driver and front-passenger with covered and illuminated vanity mirrors
S	S				Window – Rear, fixed
O	O				Window – Rear, fixed with defrost and privacy glass
O	O	S	S	S	Window – Rear, power-sliding with defroster and privacy glass¹
S					Windows – Manual front and rear
P	S	S	S	S	Windows – Power with front one-touch-up/-down feature
					Exterior
O	O	O	O	O	Bedliner – Plastic drop-in¹
O	O	O	O	O	Bedliner – Tough Bed® spray-in bedliner with tailgate guard¹
S	S	S	S	S	Beltline moldings – Black
			S		Beltline moldings – Bright
O	S	S	S	S	BoxLink™ with 4 premium locking cleats
S					Bumpers – Black-painted steel
P	S	S	P		Bumpers – Chrome
			S		Bumpers – Caribou-painted steel
			S		Bumpers – Body-color painted steel
5/0	5/0				Cab steps – Black platform running boards (standard on DRW; optional on SRW)
O	O	O			Cab steps – 5" chrome tubular step bars¹ (SRW SuperCab and Crew Cab)
O	O	S			Cab steps – 5" chrome tubular step bars¹ (DRW)
		O	O	O	Cab steps – Extended 6" chrome angular step bars
			S		Cab steps – Caribou platform running boards with lights
			O	S	Cab steps – Power-deployable running boards¹
O	O	O	O	O	Camera – Rear CHMSL camera with LED CHMSL, rear view camera and center stack display¹

XL	XLT	LARIAT	KING RANCH®	PLATINUM	
O	O	O	O	O	Camera – Customer-placed trailer camera¹
O	O	O	O	O	Camera – Customer-placed trailer camera, and Individual Trailer Tire Pressure Monitoring System (TPMS)¹
O	S	S	S	S	Camera – Rear view camera¹
O	O	O	O	O	Camera – Ultimate Trailer Tow Camera System (includes rear view camera, trailer hook-up lamp, 360-degree camera, rear CHMSL camera with LED CHMSL, and Trailer Reverse Guidance)¹
S	S				Door handles – Black
		S	S		Door handles – Body-color
		P	P	P	Door handles – Chrome
P	P	P	S		Exhaust tip – Chrome
O	O	O	O	O	Exterior backup alarm by ECCO®²
P	S	S	S	S	Fog lamps
O	O	O	O	O	Ford Telematics™ powered by Telogis®² – Fleet-tracking system (includes 1 year of service)
S					Glass – Solar-tint
O	S	S	S	S	Glass – Privacy-tint on rear doors and rear window, solar-tint on windshield and front doors¹
S					Grille – Black
P	S				Grille – Chrome 2-bar insert with Carbon Black surround
		S			Grille – Chrome 2-bar insert with chrome surround
			S		Grille – Chrome main bars with Caribou secondary bars
			S		Grille – Satin-aluminum main bars with chrome secondary bars
S	S	S	S	S	Headlamps – Dual-beam jewel-effect halogen
		O	O	S	Headlamps – Quad-beam LED with LED taillamps, fog lamps and CHMSL¹
O	O	O	O	O	Lighting – Amber LED warning strobes with CHMSL light bar and 2 hood-mounted lights by SoundOff Signal®¹,²
O	O				Lighting – Center high-mounted stop lamp (CHMSL) with cargo lamp (pickup box delete)
O	O	O	O	O	Lighting – LED box lighting with LED CHMSL
O	O	O	O	O	Lighting – LED roof marker/clearance lamps (SRW)
O	O	S	S	S	Lighting – Trailer hook-up lamp¹
		O	S		Lower-accent two-tone paint (includes accent-color wheel-lip moldings on SRW)
S					Mirrors – Manually telescoping trailer tow with 2-way fold and manual glass
P	S				Mirrors – Manually telescoping trailer tow with 2-way fold, power/heated glass, heated manual spotter mirrors, and integrated clearance lamps and turn signal indicators
		O	S	S	Mirrors – PowerScope® power-telescoping/-folding trailer tow with power/heated glass, heated manual spotter mirrors, integrated clearance lamps, turn signal indicators, high-intensity LED security approach lamps, Utility Lighting System (LED sideview mirror spotlights), and driver's side auto-dimming feature
		P	S	S	Mirrors – Memory feature for sideview mirrors
S	S				Mirrors – Black sideview mirror caps
		S	S		Mirrors – Body-color sideview mirror caps
P	P	P	S		Mirrors – Chrome sideview mirror caps

¹Restrictions may apply. See your dealer for details. ²Ford Licensed Accessory.

BUILD YOUR SUPER DUTY®

S : Standard O : Optional P : Package Content

XL	XLT	LARIAT	KING RANCH®	PLATINUM	
					Exterior (continued)
	0	0			Moonroof – Power, single-panel (SuperCab)
	0	0	0	0	Moonroof – Power, twin-panel ¹ (Crew Cab)
0	0	0	0	0	Pickup box – Bed mat ¹
S	S	S	S	S	Pickup box – Tie-down hooks, Carbon Black
P	P	P	S	S	Pickup box – Tie-down hooks, Chrome
0	0	0	S	S	Remote Start System ¹
P	S	S	S	S	SecuriCode™ keyless entry keypad
0	0	0	0	0	Skid plates – Transfer case and fuel tank (4x4)
0	0	0	0	0	Splash guards – Front ¹ (F-250/F-350)
0	0	0	0	0	Splash guards – Rear ¹
0	0	0	0	0	Stowable bed extender (SRW)
0	0	0	0	0	Stowable loading ramps
S					Tailgate – Manual lock
P	S	S	S	S	Tailgate – Power lock
		P	S	S	Tailgate – Remote release
0	0	0	0	S	Tailgate – Tailgate step with step, grab bar and tailgate lift assist
S	S				Tailgate handle – Black
P	S	S	S	S	Tailgate handle – Chrome
S	S	S	S	S	Tow hooks – Black
P	P	P	S	S	Tow hooks – Chrome
	0	0	S		Wheel-lip moldings – Accent-color ¹
0	0	0			Wheel-well liners – Rear ¹ (SRW)
					Safety & Security
0	0	S	S	S	Advanced Security Pack with inclination/intrusion sensors
P	P	S	S	S	Headlamps – Auto high beams ¹
0	0	0	0	0	Individual Trailer TPMS ¹
0	0	0	0	0	Inflatable rear safety belts in outboard seating positions ¹ (Crew Cab)
P	S	S	S	S	Perimeter alarm
					Packages
0	S	S	S	S	Power Equipment Group¹ includes accessory delay for power features; manually telescoping trailer tow mirrors with 2-way fold, power/heated glass, heated manual spotter mirrors, and integrated clearance lamps and turn signal indicators; perimeter alarm; power locks; power tailgate lock; power windows with front one-touch-up/-down feature; and Remote Keyless Entry System with 2 integrated keypad transmitter remotes
0					XL Value Package¹ includes a 4.2" center stack screen, AM/FM stereo/single-CD player with MP3 capability, cruise control, bright center caps on wheels (SRW only), and chrome front and rear bumpers

XL	XLT	LARIAT	KING RANCH	PLATINUM	
0					STX Appearance Package¹ includes AM/FM stereo/single-CD player with MP3 capability, cruise control, chrome grille with Carbon Black surround, chrome front and rear bumpers, 18" cast-aluminum wheels with bright center caps and LT275/65R18E BSW all-season tires (SRW), 17" polished forged-aluminum wheels (F-350 DRW), and STX fender vent badges
0	0				Pickup box delete¹ (F-250/F-350 with 8' box only) deletes pickup box, tailgate, rear bumper, 7-/4-pin connector, CHMSL with cargo lamp, jack, and spare wheel, tire lock, and carrier
0	0				Heavy-Service Front Suspension Package for pickup box delete ¹ (F-250 and F-350 SRW with pickup box delete) includes front springs upgrade (unless maximum springs have been computer-selected as included equipment), rear auxiliary springs (F-250), and rear stabilizer bar
0					XLT Value Package¹ includes autolock/unlock, fog lamps, power-adjustable pedals, 8-way power driver's seat (SuperCab/Crew Cab only), Reverse Sensing System, and SecuriCode keyless entry keypad
0					XLT Premium Package¹ (SuperCab/Crew Cab) includes 4.2" LCD productivity screen in instrument cluster; SYNC® 3 Enhanced Voice Recognition Communications and Entertainment System with 8" color LCD capacitive touchscreen in center stack with swiping capability, 911 Assist®, AppLink® and 2 smart-charging USB ports; 6" chrome angular step bars; 18" chrome-like PVD wheels (SRW only); autolock/unlock; chrome exhaust tip; chrome pickup bed tie-down hooks; chrome door and tailgate handles; chrome tow hooks; fog lamps; power-adjustable pedals; 8-way power driver's seat with heat; 2-way manual passenger seat with heat; Reverse Sensing System; SecuriCode keyless entry keypad; and chrome mirror caps
0					XLT Driver Assistance Package¹ includes adaptive steering, auto high beams, lane-keeping alert, Driver Alert System, leather-wrapped steering wheel, and rain-sensing windshield wipers
		0			LARIAT Value Package¹ includes heated and cooled front seats, easy-entry/-exit driver's seat with memory, LED box lighting, LED CHMSL with cargo lamp, power-adjustable pedals with memory, PowerScope trailer tow mirrors with memory, and Remote Start System
		0			LARIAT Ultimate Package¹ (Crew Cab only) includes ambient lighting, auto high beams, rain-sensing windshield wipers, heated and cooled front seats, easy entry/exit memory driver's seat, LED box lighting, LED CHMSL with cargo lamp, twin-panel moonroof, power-adjustable pedals with memory, Intelligent Access with push-button start, heated steering wheel, power-tilt/-telescoping steering column with memory, PowerScope trailer tow mirrors with memory, Remote Start System, remote tailgate release, tailgate step, and voice-activated Navigation System with integrated SiriusXM Traffic and Travel Link® with 5-year subscription
	0	0			Tow Technology Bundle includes adaptive steering, auto high beams, rain-sensing windshield wipers, lane-keeping alert, Driver Alert System, and Ultimate Trailer Tow Camera System

XL	XLT	LARIAT	KING RANCH	PLATINUM	
		0	0		Chrome Package¹ includes 6" chrome angular step bars, 18" chrome-like PVD wheels (SRW only), chrome door handles, chrome pickup bed tie-down hooks, chrome exhaust tip, chrome tow hooks, and chrome mirror caps; KING RANCH also includes chrome front and rear bumpers and chrome tailgate appliqué
			0		KING RANCH Monochromatic Paint Package¹ includes monochromatic paint; deletes Caribou wheel-lip moldings on SRW; requires Chrome Package
			0		KING RANCH Ultimate Package includes BLIS® (Blind Spot Information System) with trailer coverage and cross-traffic alert, LED CHMSL with cargo lamp, LED fog lamps, quad-beam LED headlamps, LED taillamps, twin-panel moonroof, tailgate step, power-deployable running boards, and multicontour front seats with Active Motion®
			0		PLATINUM Ultimate Package includes adaptive cruise control and collision warning with brake support, lane-keeping alert, Driver Alert System, twin-panel moonroof, and Ultimate Trailer Tow Camera System
0	0	0	0	0	9,900-lb. GVWR Package¹ (F-250)
0	0	0	0	0	10,000-lb. GVWR Package¹ (F-350 SRW)
0	0	0	0	0	11,400-lb. GVWR Package¹ (F-350 SRW)
0	0	0	0	0	5th-Wheel/Gooseneck Trailer Tow Prep Package¹ (4x4 only) includes 1 under-bed frame crossmember, 5 pickup bed 5th-wheel/gooseneck attachment points and close-out plugs, and an integrated 7-pin connector on the driver's side pickup bed wall
0	0	0	0	0	Camper Package¹ includes front springs upgrade (unless maximum springs have been computer-selected as included equipment), rear stabilizer bar (SRW), auxiliary rear springs (F-250), and slide-in camper certification
0	0	0	0	0	CNG/Propane Gaseous Engine Prep Package (F-250/F-350 gas engine only) includes hardened engine intake valves and valve seats and bi-fuel manifold
0	0	0	0	0	F-250 High-Capacity Trailer Tow Package¹ (F-250 with 8' box and diesel engine only) includes max. front springs, upgraded axles and 27,500 lb.-GCWR
0	0	0	0	0	FX4 Off-Road Package¹ (4x4 only) includes Hill Descent Control™, Rancho® front and rear shocks, transfer case and fuel tank skid plates, FX4 Off-Road box decals (box decals not included on PLATINUM)
0	0	0	0	0	Heavy-Service Front Suspension Package¹ includes front springs upgrade (unless maximum springs have been computer-selected as included equipment)
0	0	0	0	0	Snow Plow Prep Package¹ (4x4 only) includes computer-selected springs for snow plow application, and extra-heavy-duty alternator
0	0	0	0	0	Snow Plow/Camper Package¹ includes computer-selected front springs for snow plow application, extra-heavy-duty alternator, rear stabilizer bar (SRW), auxiliary rear springs (F-250), and slide-in camper certification

¹Restrictions may apply. See your dealer for details.

WHEELS



17" Argent-Painted Steel
with Painted Center Cap
Standard: F-250/F-350 SRW XL



18" Argent-Painted Steel
with Painted Center Cap
Optional: F-350 SRW XL



17" Cast-Aluminum
with Bright Center Cap
Optional: F-250/F-350 SRW XL & XLT



18" Cast-Aluminum
with Bright Center Cap
Standard: F-250/F-350 SRW XLT
Included: F-250/F-350 SRW XL
with STX Appearance Package



18" Chrome-Like PVD
with Bright Center Cap
Included: F-250/F-350 SRW XLT
with XLT Premium Package
& LARIAT with Chrome Package



18" Bright-Machined Cast-Aluminum
with Bright Center Cap
Standard: F-250/F-350 SRW LARIAT



20" Premium Cast-Aluminum
with Bright Center Cap
Optional: F-250/F-350 SRW 4x4 LARIAT



20" Chrome-Like PVD
with Bright Center Cap
Optional: F-250/F-350 SRW 4x4
LARIAT with Chrome Package¹



20" Chrome-Like PVD
with Bright Center Cap
Optional: F-350 SRW 4x4 Diesel
LARIAT with Chrome Package



18" Bright-Machined Cast-Aluminum
with KING RANCH Center Cap
Standard: F-250/F-350 SRW
KING RANCH



18" Chrome-Like PVD
with KING RANCH Center Cap
Included: F-250/F-350 SRW
KING RANCH with Chrome Package



20" Premium Painted Cast-Aluminum
with KING RANCH Center Cap
Optional: F-250/F-350 SRW 4x4
KING RANCH



20" Chrome-Like PVD
with KING RANCH Center Cap
Optional: F-250/F-350 SRW 4x4
KING RANCH with Chrome Package¹



20" Chrome-Like PVD
with KING RANCH Center Cap
Optional: F-350 SRW 4x4 Diesel
KING RANCH with Chrome Package



20" Polished Aluminum
with Bright Center Cap
Standard: F-250/F-350 SRW PLATINUM



20" Polished Aluminum
with Bright Center Cap
Standard: F-350 SRW Diesel PLATINUM



17" Argent-Painted Steel
Standard: F-350 DRW XL & XLT



17" Argent-Painted Steel
with Stainless Steel Covers
Optional: F-350 DRW XL & XLT



17" Polished Forged-Aluminum
with Bright Center Cap
Optional: F-350 DRW XL & XLT
Standard: F-350 DRW LARIAT & PLATINUM
Included: F-350 DRW XL
with STX Appearance Package



17" Polished Forged-Aluminum
with KING RANCH® Center Cap
Standard: F-350 DRW KING RANCH



19.5" Polished Forged-Aluminum
with Bright Center Cap
Standard: F-450 XL, XLT,
LARIAT & PLATINUM



19.5" Polished Forged-Aluminum
with KING RANCH Center Cap
Standard: F-450 KING RANCH

¹Restrictions may apply. See your dealer for details.

TECHNICAL SPECIFICATIONS

Maximum Payload Weight Ratings (lbs.)

	Max. GVWR	Regular Cab		SuperCab		Crew Cab		
		141.5" WB	147.9" WB	164.1" WB	159.7" WB	175.9" WB		
F-250 SRW 4x2	9,900	4,150	3,900	3,810	3,780	3,540		
	9,950	4,200	—	—	—	—		
	10,000	3,440	4,000	3,910	3,880	3,640		
F-250 SRW 4x4	9,900	3,730	3,460	3,390	3,350	3,130		
	10,000	3,830	3,560	3,490	3,450	3,230		
F-350 SRW 4x2	9,900	3,930	3,710	3,590	3,550	3,310		
	10,000	4,030	3,810	3,690	3,650	3,410		
	10,100	—	—	—	3,750	—		
	10,300	—	—	3,990	—	—		
	10,500	—	4,250	—	—	3,910		
	10,600	3,880	—	—	4,200	—		
	10,800	—	3,870	4,430	—	—		
	10,900	—	—	—	3,790	4,260		
	11,000	—	—	3,940	—	—		
	11,100	4,320	—	—	—	3,760		
	11,200	—	4,220	—	—	—		
	11,300	—	—	—	4,130	—		
	11,400	—	—	4,280	—	4,000		
	11,500	—	—	4,380	—	4,100		
	F-350 SRW 4x4	9,900	3,500	3,290	3,180	3,140	2,900	
10,000		3,600	3,390	3,280	3,240	3,000		
10,300		3,900	—	—	—	—		
10,400		—	3,790	—	—	—		
10,500		—	—	—	3,740	—		
10,700		—	—	3,980	—	—		
10,800		4,340	4,130	—	—	3,800		
10,900		—	—	—	4,080	—		
11,000		3,850	—	—	—	—		
11,100		—	3,750	—	—	—		
F-350 DRW 4x2	13,000 ¹	6,270 ¹	—	5,880 ¹	—	5,650 ¹		
	14,000	7,630	—	7,200	—	6,950		
	F-350 DRW 4x4	13,000 ¹	5,850 ¹	—	5,470 ¹	—	5,240 ¹	
		14,000	7,160	—	6,780	—	6,540	
	F-450 DRW 4x4	14,000	—	—	—	—	5,320	

Maximum Loaded Trailer Towing Weight Ratings (lbs.) – SAE J2807 Compliant

	Engine	Axle Ratio	GCWR	Regular Cab			SuperCab			Crew Cab		
				Conventional Weight Carrying	Towing Weight Distribution	5th-Wheel/Gooseneck Towing	Conventional Weight Carrying	Towing Weight Distribution	5th-Wheel/Gooseneck Towing	Conventional Weight Carrying	Towing Weight Distribution	5th-Wheel/Gooseneck Towing
F-250 SRW 4x2	6.2L Gas	3.73	19,500	13,000	13,300	13,200	13,000	13,000	13,000	12,900	12,900	12,900
		4.30	22,000	13,000	14,000	15,700	13,000	14,000	15,500	14,000	15,000	15,400
	6.7L Diesel	3.31/3.55	24,300	—	—	—	—	—	—	—	—	16,800 ²
			24,800	—	—	—	—	—	17,400 ²	—	—	—
F-250 SRW 4x4	6.2L Gas	3.73	19,500	12,900	12,900	12,800	12,600	12,600	12,600	12,500	12,500	12,500
		4.30	22,000	15,000	15,000	15,300	15,000	15,000	15,100	15,000	15,000	15,000
	6.7L Diesel	3.31/3.55	21,900	—	—	—	—	—	—	—	—	14,000 ²
			22,500	—	—	—	—	—	14,700 ²	—	—	—
	6.7L Diesel	3.31/3.55	24,100	—	—	16,500 ²	—	—	—	—	—	—
			25,200	—	—	—	15,000 ²	15,000 ²	—	—	—	—
F-350 SRW 4x2	6.2L Gas	3.73	19,500	13,000	13,100	13,000	12,900	12,900	12,800	12,700	12,700	12,700
		4.30	23,000	13,000	14,000	16,500	13,000	14,000	16,300	15,000	15,000	16,200
	6.7L Diesel	3.31/3.55	28,700	14,000	15,000	21,500 ³	15,000	15,000	21,300 ³	18,000	18,000	21,000 ³
			28,700	14,000	15,000	21,100 ³	15,000	15,000	20,900 ³	15,000	15,000	20,600 ³
F-350 SRW 4x4	6.2L Gas	3.73	19,500	12,600	12,600	12,600	12,400	12,400	12,400	12,300	12,300	12,200
		4.30	23,000	15,000	15,000	16,100	15,000	15,000	15,900	15,000	15,000	15,700
	6.7L Diesel	3.31/3.55	28,200	—	—	—	—	—	—	—	—	20,000 ³
			28,700	14,000	15,000	21,100 ³	15,000	15,000	20,900 ³	15,000	15,000	20,600 ³
F-350 DRW 4x2	6.2L Gas	3.73	20,000	13,200	13,200	13,100	12,700	12,700	12,700	12,500	12,500	12,500
		4.30	23,500	16,700	16,700	16,600	16,200	16,200	16,200	16,000	16,000	16,000
	6.7L Diesel	3.55	36,000	18,000	21,000	28,400 ⁴	18,000	21,000	28,000 ⁴	19,000	21,000	27,700 ⁴
			40,000	18,000	21,000	32,000 ⁴	18,000	21,000	32,000 ⁴	19,000	21,000	31,700 ⁴
F-350 DRW 4x4	6.2L Gas	3.73	20,000	12,700	12,700	12,700	12,300	12,300	12,300	12,100	12,100	12,100
		4.30	23,500	16,200	16,200	16,200	15,800	15,800	15,800	15,600	15,600	15,600
	6.7L Diesel	3.55	36,000	18,000	20,000	27,900 ⁴	19,000	21,000	27,600 ⁴	21,000	21,000	27,300
			40,000	18,000	20,000	31,900 ⁴	19,000	21,000	31,600 ⁴	21,000	21,000	31,300 ⁴
F-450 DRW 4x4	6.7L Diesel	4.30	41,800	—	—	—	—	—	—	21,000	21,000	32,500 ⁴

[CLICK HERE to download full towing charts](#)

SRW = single rear wheel DRW = dual rear wheel WB = wheelbase ¹Pickup box delete. ²Requires F-250 High-Capacity Trailer Tow Package. ³Gooseneck tow rating shown. 5th-wheel tow rating limited to 5th-wheel hitch rating of 18,000 lbs. ⁴Gooseneck tow rating shown. 5th-wheel tow rating limited to 5th-wheel hitch rating of 27,500 lbs.

Maximum capabilities shown are for properly equipped vehicles with required equipment and a 150-lb. driver. Weight of additional options, equipment, passengers and cargo must be deducted from this weight. For additional information, see your Ford Dealer. **Conventional Towing Notes:** This information also applies to models with Pickup Box Delete option (66D). Trailer tongue load weight should be 10–15% of total loaded trailer weight. Make sure that the vehicle payload (reduced by option weight) will accommodate trailer tongue load weight and the weight of passengers and cargo added to the towing vehicle. The addition of trailer tongue load weight, and the weight of passengers and cargo, cannot cause vehicle weights to exceed the rear GAWR (Gross Axle Weight Rating) or GVWR (Gross Vehicle Weight Rating). These ratings can be found on the vehicle's Safety Compliance Certification Label. **5th-Wheel Towing Notes:** This information also applies to models with pickup box delete option (66D). Trailer kingpin weight should be 15–25% of total loaded trailer weight. Make sure that the vehicle payload (reduced by option weight) will accommodate trailer kingpin weight and the weight of passengers and cargo added to the towing vehicle. The addition of trailer kingpin weight, and the weight of passengers and cargo, cannot cause vehicle weights to exceed the rear GAWR (Gross Axle Weight Rating) or GVWR (Gross Vehicle Weight Rating). These ratings can be found on the vehicle's Safety Compliance Certification Label.

TECHNICAL SPECIFICATIONS

Dimensions

Exterior	Regular Cab	SuperCab	Crew Cab		
	LWB 4x2/4x4	SWB 4x2/4x4	LWB 4x2/4x4	SWB 4x2/4x4	LWB 4x2/4x4
A. Height – F-250 SRW (w/o options)	77.9"/81.1"	78.4"/81.5"	78.1"/81.4"	78.3"/81.5"	78.0"/81.3"
A. Height – F-350 SRW (w/o options)	77.8"/80.9"	78.2"/81.3"	78.0"/81.2"	78.2"/81.3"	78.0"/81.1"
A. Height – F-350 DRW (w/o options)	78.1"/80.6"	—	77.8"/80.9"	—	77.9"/81.0"
A. Height – F-450 DRW (w/o options)	—	—	—	—	81.0"
B. Width – SRW (excl. mirrors)	80.0"	80.0"	80.0"	80.0"	80.0"
B. Width – DRW (excl. mirrors)	96.0"	—	96.0"	—	96.0"
B. Width – With mirrors	105.9"	105.9"	105.9"	105.9"	105.9"
B. Width – With mirrors extended	110.0"	110.0"	110.0"	110.0"	110.0"
C. Ground clearance – F-250 SRW	8.5"/8.3"	8.5"/8.2"	8.5"/8.2"	8.5"/8.2"	8.5"/8.2"
C. Ground clearance – F-350 SRW	8.5"/8.2"	8.5"/8.2"	8.5"/8.2"	8.5"/8.2"	8.5"/8.2"
C. Ground clearance – F-350 DRW	7.8"/7.7"	—	7.8"/7.8"	—	7.8"/7.8"
C. Ground clearance – F-450 DRW	—	—	—	—	8.3"
D. Load floor height – F-250 SRW	36.1"/38.7"	35.6"/38.3"	35.3"/38.1"	35.3"/38.1"	34.8"/37.9"
D. Load floor height – F-350 SRW	35.7"/38.5"	35.4"/38.1"	35.0"/37.9"	35.0"/38.0"	34.6"/37.6"
D. Load floor height – F-350 DRW	36.5"/37.6"	—	34.4"/37.2"	—	34.3"/36.9"
D. Load floor height – F-450 DRW	—	—	—	—	36.9"
E. Cargo box height	21.1"	21.1"	21.1"	21.1"	21.1"
F. Length	231.8"	238.2"	254.4"	250.0"	266.2"
G. Overhang – Rear	52.0"	52.0"	52.0"	52.0"	52.0"
H. Wheelbase	141.6"	148.0"	164.2"	159.8"	176.0"
I. Overhang – Front	38.2"	38.2"	38.2"	38.2"	38.2"
J. Angle of departure – F-250 SRW	19.8°/22.7°	19.3°/22.3°	19.0°/22.1°	19.0°/22.1°	18.4°/21.8°
J. Angle of departure – F-350 SRW	18.7°/21.8°	18.4°/21.4°	18.0°/21.2°	17.9°/21.2°	17.6°/20.9°
J. Angle of departure – F-350 DRW	19.5°/20.9°	—	17.4°/20.5°	—	17.2°/20.1°
J. Angle of departure – F-450 DRW	—	—	—	—	20.2°
K. Ramp breakover angle – F-250 SRW	20.2°/25.4°	19.3°/24.2°	17.8°/22.5°	18.0°/22.6°	16.9°/21.1°
K. Ramp breakover angle – F-350 SRW	20.0°/25.1°	19.0°/23.9°	17.7°/22.3°	17.8°/22.4°	16.7°/20.9°
K. Ramp breakover angle – F-350 DRW	20.6°/24.6°	—	17.4°/21.8°	—	16.7°/20.8°
K. Ramp breakover angle – F-450 DRW	—	—	—	—	19.6°
L. Angle of approach – F-250 SRW	17.2°/18.1°	17.6°/17.9°	17.8°/18.7°	17.4°/17.9°	18.1°/18.4°
L. Angle of approach – F-350 SRW	17.5°/17.8°	17.3°/17.7°	18.0°/18.4°	17.6°/17.5°	17.9°/18.1°
L. Angle of approach – F-350 DRW	17.6°/18.1°	—	18.3°/18.4°	—	18.5°/19.1°
L. Angle of approach – F-450 DRW	—	—	—	—	18.9°
Interior					
Front head room	40.8"	40.8"	40.8"	40.8"	40.8"
Front leg room (max.)	43.9"	43.9"	43.9"	43.9"	43.9"
Front hip room	62.5"	62.5"	62.5"	62.5"	62.5"
Front shoulder room	66.7"	66.7"	66.7"	66.7"	66.7"
Rear head room	—	40.3"	40.3"	40.4"	40.4"
Rear leg room	—	33.5"	33.5"	43.6"	43.6"
Rear hip room	—	64.7"	64.7"	64.7"	64.7"
Rear shoulder room	—	65.8"	65.8"	65.9"	65.9"
Cargo Box					
Volume (cu. ft.)	78.5	65.4	78.5	65.4	78.5
M. Length at floor	98.1"	81.9"	98.1"	81.9"	98.1"
N. Width at wheelhouse	50.5"	50.5"	50.5"	50.5"	50.5"
O. Width at floor (max.)	66.9"	66.9"	66.9"	66.9"	66.9"

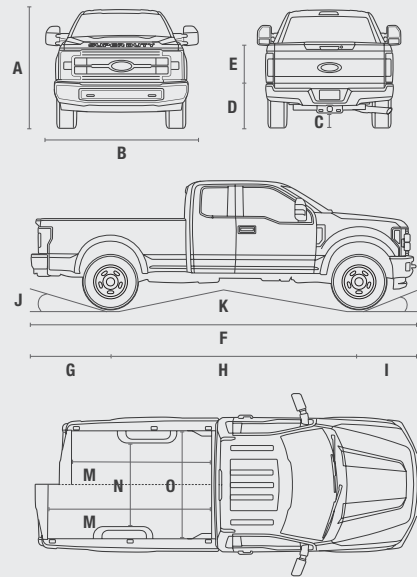

Interior Storage (cu. ft.)

Front 40/20/40 split seat center under-seat lockable storage – 0.42
 Front flow-through center console main bin – 1.18
 Rear Crew Cab 60/40 split bench under-seat lockable storage – 2.27

EXTERIOR & INTERIOR CHOICES

	Two-Tone	XL	XLT	LARIAT	KING RANCH®	PLATINUM
White Platinum						
Metallic Tri-coat ¹	■ ■			5 6	7	8 9
Oxford White	■ ■	1 2	3 4	5 6	7	
Ingot Silver ²	■	1 2	3 4	5 6		8 9
White Gold ²	■		4	5 6	7	8 9
Caribou ²		1 2	3 4	5 6	7 ³	
Bronze Fire ²	■		4	5 6	7	

	Two-Tone	XL	XLT	LARIAT	KING RANCH	PLATINUM
Race Red		1 2	3 4	5 6		
Ruby Red Metallic Tinted Clearcoat ¹	■ ■		3 4	5 6	7	8 9
Blue Jeans ²	■ ■	1 2	3 4	5 6	7	
Magnetic ²		1 2	3	6		8 9
Shadow Black	■ ■	1 2	3 4	5 6	7	8 9

■ Caribou Two-Tone Accent exterior standard on KING RANCH; optional on LARIAT
 ■ Magnetic Two-Tone Accent exterior optional on LARIAT with Black Leather interior only

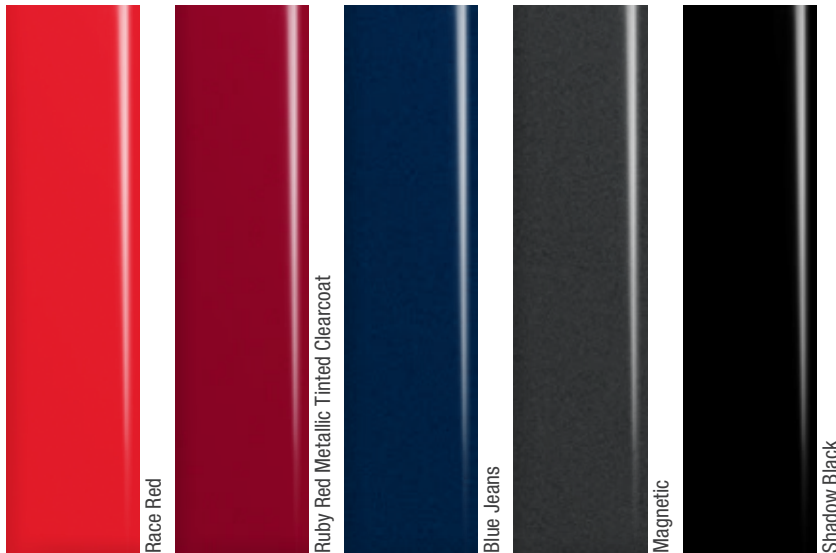
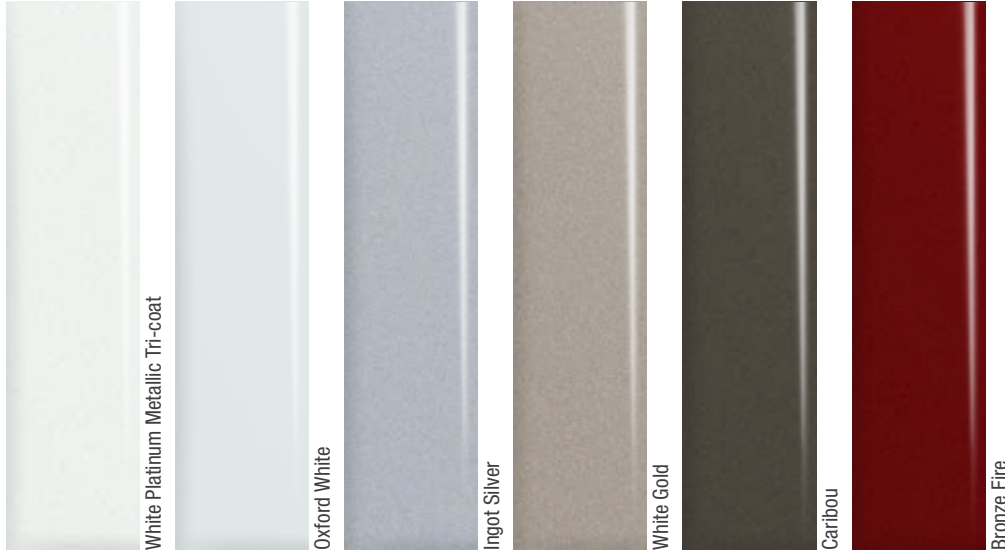

Colors are representative only. See your dealer for actual paint/trim options. ¹Additional charge. ²Metallic. ³Requires KING RANCH Monochromatic Paint Package.



FORD ACCESSORIES

XLT with XLT Value Package in Oxford White accessorized with 5" Black step bars, hood and side window deflectors, hard-folding tonneau cover by Advantage,² heavy-duty splash guards, chrome front tow hooks, LED fog lamps by Putco,⁴ and rear wheel-well liners

Exterior

- Exhaust tips
- Exterior trim kits¹
- Fender flares¹
- Fifth-wheel hitch kits (A)
- Fog lamps¹
- Ford Custom graphics¹
- Hood and side window deflectors
- Hood protector¹
- Racks and carriers¹
- Splash guards
- Sportz[®] tents¹
- Stainless steel wheel covers¹
- Step bars
- Trailer towing accessories
- Wheel lock kit
- Wheel-well liners

Interior

- Ash cup/coin holders
- Cargo organizers and protectors
- First aid and roadside assistance kits¹
- Floor liners (B)
- In-vehicle safe¹
- Interior light kit
- Leather-trimmed interior seating¹
- Protective seat covers¹
- Tablet cradle¹

Bed Products

- Bed cleats and cargo nets
- Bed extenders, liners and mats
- Bed rails¹
- Bed standard interface plate
- Bed tailgate viscous dampening cartridge

Bedliner plug kits

- Commercial-grade tool/cargo box¹
- Pivot storage box¹
- Retractable stake pocket tie-downs¹
- Sportliners¹
- Stowable loading ramps (C)
- Tonneau covers¹

Electronics

- Ford Telematics powered by Telogis^{®1}
- Keyless entry keypad
- Remote start systems (D)
- Strobe and work task lights¹
- Vehicle Security System
- Warning sensor systems¹
- Wireless charging¹



accessories.ford.com

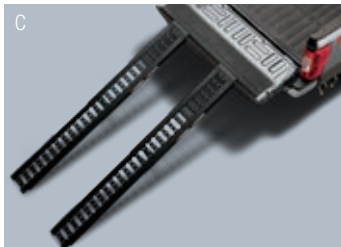

New Vehicle Limited Warranty. We want your Ford F-Series Super Duty[®] ownership experience to be the best it can be. Under this warranty, your new vehicle comes with 3-year/36,000-mile bumper-to-bumper coverage, 5-year/60,000-mile Powertrain Warranty coverage, 5-year/60,000-mile safety restraint coverage, and 5-year/unlimited-mile corrosion (perforation) coverage – all with no deductible. The Ford 6.7L Power Stroke[®] diesel engine gets 5-year/100,000-mile warranty coverage. Please ask your Ford Dealer for a copy of this limited warranty.

Roadside Assistance. Covers your vehicle for 5 years or 60,000 miles, so you have the security of knowing that help may be only a phone call away should you run out of fuel, lock yourself out of the vehicle or need towing. Your Ford Dealer can provide complete details on all of these advantages.

Ford Credit. Get the ride you want. Whether you plan to lease or finance, you'll find the choices that are right for you at Ford Credit. Ask your Ford Dealer for details or check us out at fordcredit.com.

Ford Protect Extended Service Plans. Whether you purchase or lease your Ford vehicle, insist on genuine Ford Protect extended service plans. Ford Protect has a variety of plans to give you peace-of-mind protection whether you want vehicle component or maintenance coverage. Plus, they are fully backed by Ford and honored at all Ford dealerships in the U.S., Canada and Mexico. When you visit your dealer, insist on genuine Ford Protect extended service plans.

Insurance Services. Get Ford Motor Company quality in your auto insurance. Our program offers industry-leading benefits and competitive rates. Call 1-877-367-3847, or visit us at fordvip.com for a no-obligation quote. Insurance offered by American Road Services Company (in CA, American Road Insurance Agency), a licensed agency and subsidiary of Ford Motor Company.

Ford Original Accessories. They're warranted for whichever provides you the greatest benefit: 24 months/unlimited mileage, or the remainder of your Bumper-to-Bumper 3-year/36,000-mile New Vehicle Limited Warranty. Ford Licensed Accessories (FLA) are warranted by the accessory manufacturer's warranty. FLA are designed and developed by the accessory manufacturer and have not been designed or tested to Ford Motor Company engineering requirements. Contact your Ford Dealer for details and/or a copy of all limited warranties.

Android Auto, Google, Google Play and other marks are trademarks of Google Inc. Apple, Apple CarPlay, iPhone and Siri are trademarks of Apple Inc., registered in the U.S. and other countries. "HD Radio" is a proprietary trademark of iBiquity Digital Corporation. King Ranch is a registered trademark of King Ranch, Inc. PANDORA, the PANDORA logo, and the Pandora trade dress are trademarks or registered trademarks of Pandora Media, Inc. Used with permission. Rancho is a registered trademark of Tenneco Automotive Operating Company Inc. SiriusXM audio and data services each require a subscription sold separately, or as a package, by Sirius XM Radio Inc. If you decide to continue service after your trial, the subscription plan you choose will automatically renew thereafter and you will be charged according to your chosen payment method at then-current rates. Fees and taxes apply. To cancel you must call SiriusXM at 1-866-635-2349. See SiriusXM Customer Agreement for complete terms at www.siriusxm.com. All fees and programming subject to change. Trial subscriptions not available in AK and HI. Sirius, XM and all related marks and logos are trademarks of Sirius XM Radio Inc. Sony is a registered trademark of the Sony Corporation. Wi-Fi[®] is a registered trademark of the Wi-Fi Alliance.[®]

Comparisons based on competitive models (class is Full-Size Pickups over 8,500 lbs. GVWR based on Ford segmentation), publicly available information and Ford certification data at time of release. Vehicles may be shown with optional and aftermarket equipment. Features may be offered only in combination with other options or subject to additional ordering requirements/limitations. Dimensions and capacity ratings shown may vary due to optional features and/or production variability. Information is provided on an "as is" basis and could include technical, typographical or other errors. Ford makes no warranties, representations, or guarantees of any kind, express or implied, including but not limited to, accuracy, currency, or completeness, the operation of the information, materials, content, availability, and products. Ford reserves the right to change product specifications, pricing and equipment at any time without incurring obligations. Your Ford Dealer is the best source of the most up-to-date information on Ford vehicles. Body manufacturers are responsible for compliance certification of the completed vehicle. The Ford New Vehicle Limited Warranty and any government certification made by Ford shall cover only the vehicle as manufactured by Ford and shall not extend to any addition, modification or change of or to the vehicle by the Ford Authorized Pool Account.

¹Ford Licensed Accessory.